

SKF high-capacity cylindrical roller bearings

Full complement bearings with a cage



Higher load ratings and longer service life

Applications like industrial gearboxes, gearboxes in wind turbines or machines for mining equipment require components that can provide high operational reliability and long service life. In these applications, load carrying capacity is particularly important, which is the reason why full complement bearings are frequently used.

Full complement bearings do not have a cage separating the rollers, which enables a maximum number of rollers.

Therefore, the advantage of full complement bearings is that they can accommodate much heavier loads than same-sized bearings with a cage.

However, direct roller-to-roller contact in a full complement bearing increases friction, heat generation and the risk for wear. Consequently, the permissible speed is reduced. Under particularly difficult operating conditions, these disadvantages quickly add up to substantially reduced bearing service life.

To achieve the maximum load carrying capacity of a full complement bearing and the robust performance of a bearing with a cage, SKF developed high-capacity cylindrical roller bearings. These bearings combine the advantages of both bearing types.



SKF high-capacity cylindrical roller bearings with an inner ring or outer ring shoulder-guided cage

An innovative bearing design

Traditionally, higher load carrying capacities have been achieved by incorporating larger rollers. However, to do this within the ISO standardized boundary dimensions requires thinner rings. Thinner rings increase the risk of ring creep, ring or flange cracks, and fretting corrosion. Also, larger rollers are more prone to smearing due to increased inertial forces.

The new SKF high-capacity cylindrical roller bearings (→ **fig. 1**), which contain more rollers than EC design cylindrical roller bearings, not only maintain the original ISO boundary dimensions, they also maintain the internal geometry of the EC design. The result: increased dynamic and static load carrying capacities and consequently longer bearing service life.

Reduced risk of roller sliding

SKF high-capacity cylindrical roller bearings are specially designed to accommodate the requirements of wind turbines and applications where high load carrying capacity is a prerequisite. In these applications bearings must frequently operate below the requisite minimum load. Under these conditions, the inertial forces of the rollers and cage, and the friction in the lubricant, can have a detrimental effect on the rolling conditions in the bearing arrangement and may cause damaging sliding movement between the rollers and raceways.

With the inner ring shoulder-guided cage of SKF high-capacity cylindrical roller bearings, this risk is reduced. When operating

below the recommended minimum radial load, the sliding ratio for these bearings with an inner ring shoulder-guided cage is significantly lower than for conventional cylindrical roller bearings with a cage of the same size. For bearings in the 22 dimension series, the risk for sliding damage is even more reduced than for 23 series bearings. 22 series bearings have a lower cross section and smaller rollers, which results in lower inertial forces.

The rollers are coated with black oxide to further reduce the risk of sliding damage inside the bearing during initial start-up.

A sustainable product

SKF high-capacity cylindrical roller bearings were designed to support SKF's Beyond Zero sustainability efforts. Through this initiative, SKF is committed to creating products that consume less energy when in use than the energy needed to manufacture them.

From an environmental standpoint, these bearings can provide the following benefits:

- lower frictional losses
- possibility for downsizing
- increased bearing service life

The components of SKF high-capacity cylindrical roller bearings are all made of steel, enabling easy recycling.

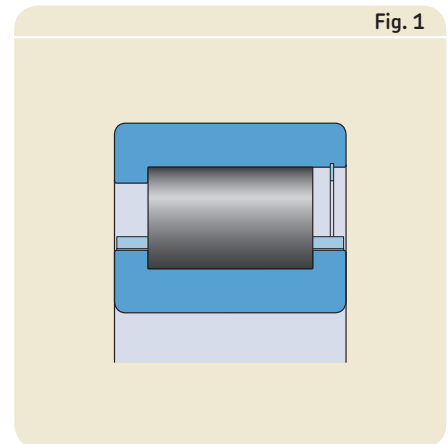

Cross section of an SKF high-capacity cylindrical roller bearing

Performance advantage

Optimized cage design

The key to the new SKF high-capacity cylindrical roller bearing lies in its new cage design. The design of this steel cage goes beyond the design of traditional machined brass cages.

The new window-type steel cage is designed so that its cage bars are displaced relative to the roller pitch diameter. This does not have an unfavourable effect on the strength of the cage bars, but enables the rollers to be placed closer to each other, creating room for additional rollers.

Advanced modelling techniques have been used to optimize the cage design. The shape of the cage bars minimizes stress concentration and enhances lubricant film formation. The low cross-sectional height of the cage promotes oil flow through the bearing and quick formation of a lubricant film.

The low weight of the cage reduces inertial forces, which improves the sliding behaviour of the cage, especially under light load conditions.

The cage can be either inner or outer ring shoulder-guided (→ **fig. 2**). Shoulder-guided cages are beneficial if high speed, rapid acceleration or shock load occur.

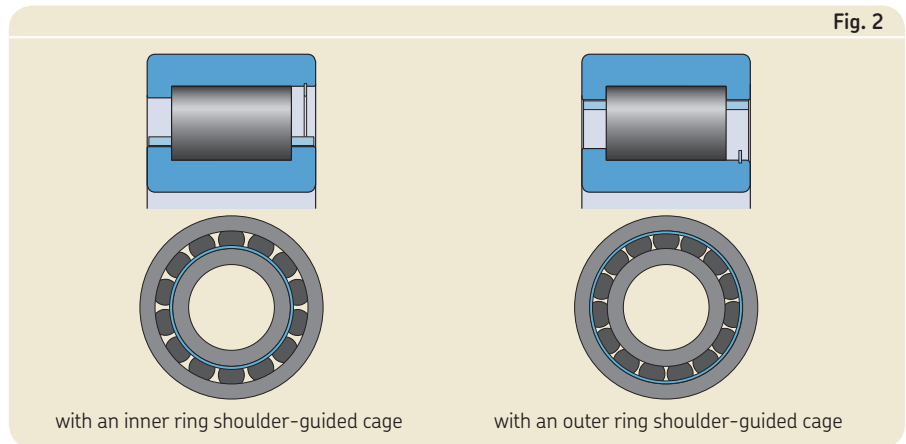

SKF high-capacity cylindrical roller bearings with an inner ring and outer ring shoulder-guided cage

Optimized roller set

To minimize the risk of smearing or wear, especially during the running-in phase, the rollers in SKF high-capacity cylindrical roller bearings have been coated, as standard, with black oxide.

The increased number of rollers enables higher static and dynamic load ratings compared to standard cylindrical roller bearings with a cage.

The SKF Explorer advantage

In contrast to full complement cylindrical roller bearings, all SKF high-capacity cylindrical roller bearings are available in the SKF Explorer performance class. The SKF Explorer performance class is standard for bearings in the 23 series up to a 150 mm bore diameter and for bearings in the 22 series up to a 200 mm bore diameter. SKF Explorer performance class bearings provide the following benefits compared to standard bearings:

- longer bearing life
- reduced friction losses
- extended maintenance intervals
- higher load carrying capacity
- improved wear-resistance
- lower energy consumption
- lower cost of ownership
- increased productivity
- lower noise and vibration levels

A higher level of performance

When compared to full complement cylindrical roller bearings, SKF Explorer high-capacity cylindrical roller bearings undergo a number of enhancements. These enhancements are designed to improve reliability and increase the service life of the bearing, even in the most demanding applications.

The superior performance of SKF Explorer class bearings is mainly achieved by three key features.

Extremely clean steel

SKF Explorer bearing quality starts at the most basic level, with steel that is extremely clean and has the lowest possible number of impurities. By using only steel that is highly homogenous, SKF bearings have the same material strength throughout, without weak spots. It is this high-purity material that gives SKF Explorer bearings their exceptional strength and durability. It also enables the steel to withstand SKF's unique heat treatment process, which further enhances performance.

Unique heat treatment process

To cope with extreme operating conditions like those in wind turbine gearboxes, SKF Explorer high-capacity cylindrical roller bearing components undergo a customized heat treatment process that enhances toughness and reduces the possibility of premature bearing failure.

Advanced surface finish

The surface topography of the rolling elements and raceways of SKF Explorer bearings has been optimized, through advanced processes, to create an optimal combination of properties that reduce friction and enhance the formation of a hydrodynamic film. This maximizes the effects of the lubricant, while reducing heat generation, noise and vibration levels.

Recommended for wind energy applications

SKF Explorer high-capacity cylindrical roller bearings, with their optimized surface finish, are recommended for the typical conditions in wind energy applications. Conventional bearings used in such applications can suffer from frequent starts and stops, because after each start it takes a certain time to build up the lubricant film. SKF Explorer high-capacity cylindrical roller bearings have a surface finish, which quickly promotes the formation of a lubricant film.



Functionality and long-term tests

Light-load test

Focusing only on high load carrying capacity becomes risky if loads can vary and drop below the required minimum load. This is even more critical at high speeds where the roller-slip ratio (relative sliding between the rollers and raceways) can increase.

Under these high-speed, light-load conditions, the inertial forces, combined with inadequate lubrication, can substantially increase the risk of smearing, which can quickly cause bearings to fail. Therefore, SKF high-capacity cylindrical roller bearings were also tested under minimum load conditions to determine the level of roller and cage slip.

The minimum load tests were conducted with less than 10% of the recommended minimum load as prescribed in the *SKF General Catalogue*. The test results showed that for SKF high-capacity cylindrical roller bearings with an inner ring shoulder-guided steel cage, the roller-slip ratio within the bearing is reduced by up to 50%, when compared to a bearing with a standard brass cage, despite the additional roller(s) (→ **diagram 1**).

Even under almost no load and under poor lubrication conditions, the roller-slip ratio of SKF high-capacity cylindrical roller bearings did not reach the limit considered critical for failures due to light loads.

Cage speed and functionality test

To substantiate claims of improved performance, functional validation tests under varying conditions were conducted by SKF.

To assess speed capability and cage stability, tests were performed to compare the performance of SKF high-capacity cylindrical roller bearings to bearings containing a standard shoulder-guided brass cage.

The tests were conducted under different lubrication conditions. In one case, oil with a proper viscosity, which provides a sufficient oil film ($\kappa > 1,5$) was used. In another test, a low-viscosity oil to simulate an inadequate lubrication condition ($\kappa < 0,5$) was used.

When the functional tests were completed, endurance tests were conducted to compare high-capacity cylindrical roller bearings with standard design cylindrical roller bearings containing a brass cage. During all the tests, critical performance parameters such as temperature, loads, speed and vibration levels were monitored continuously.

Based on the endurance test results and an in-depth examination of the various bearing components after the test, no limitations could be found for the SKF high-capacity cylindrical roller bearing compared to bearings with a standard cage.

Field experience

Several sizes of SKF high-capacity cylindrical roller bearings have been running successfully for years in wind turbine applications. Several bearing inspections since 2006 show the superior performance in these applications.

Diagram 1

Comparison of cage slip at different radial loads

Cage slip [%]

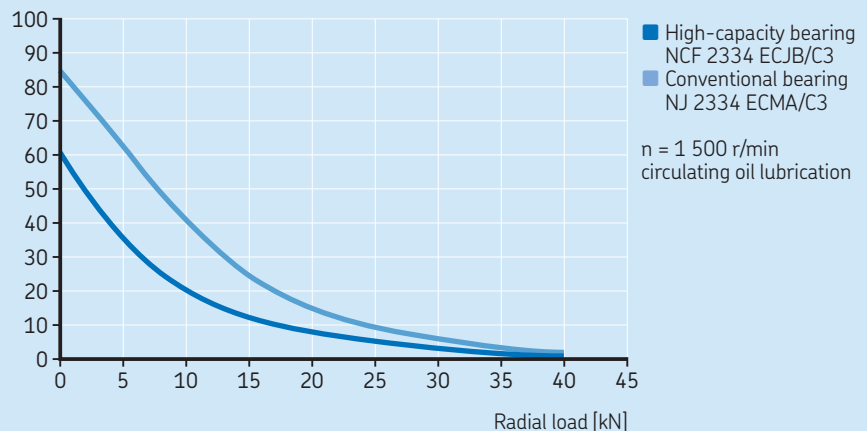

Recommendations for bearing arrangement design

Load carrying capacity and life

The basic rating life, calculated in accordance with ISO 281:2007, is also applicable for SKF high-capacity cylindrical roller bearings. When comparing the calculated bearing life of a standard bearing with a cage to the life of a same-sized high-capacity bearing, there is a possibility of increasing bearing life up to 45%.

To take full advantage of the increased load carrying capacity and improved wear-resistance of SKF Explorer bearings, always use the SKF rating life method when calculating bearing life. For additional information about bearing calculations, refer to the *SKF General Catalogue* or the *SKF Interactive Engineering Catalogue*, available online at www.skf.com.

Friction

Friction influences the heat generated by a bearing. The amount of friction depends on several factors such as load, speed, lubricant and others.

For SKF high-capacity cylindrical roller bearings, the frictional moment can be calculated with the new SKF model for calculating a frictional moment. The model, which provides a more accurate result than standard calculations, takes the lubricant, applied loads and bearing design into consideration. The calculations are complex but can be performed easily using the *SKF Interactive Engineering Catalogue*, available online at www.skf.com.

When calculating the frictional moment according to the *SKF General Catalogue*, the factors for bearings with a cage (N, NU, NJ or NUP designs) have to be used instead of the factors for full complement bearings (NCF or NJG designs).

Speed capability

The speed capability of a bearing depends on several factors, including the strength of the cage, the geometry of the rolling elements and raceways and the lubrication method.

The reference speeds listed in the product tables are the same for both standard and high-capacity cylindrical roller bearings.

The limiting speeds are much higher than those of full complement cylindrical roller bearings. If an SKF high-capacity cylindrical roller bearing has to be operated at higher speeds than the limiting speed, contact the SKF application engineering service.

Recommended fits

Tolerances for the bore and outside diameter of rolling bearings are internationally standardized.

Therefore, SKF high-capacity cylindrical roller bearings have the same fits as standard cylindrical roller bearings with a cage. The appropriate fit depends on the application, applied load, operating conditions and possible displacement of the inner ring. For the typical normal to heavy load applications, such as in wind turbines and other applications where SKF high-capacity cylindrical roller bearings are used, very often a p6 or r6 shaft fit is recommended. With a p6 and r6 fit, radial clearance greater than Normal is recommended.

For additional information and fit recommendations, refer to the *SKF General Catalogue*.

Lubrication

SKF recommends oil lubrication for high-capacity cylindrical roller bearings because they have a shoulder-guided cage. The low cross-section of the cage and the unique shape of the cage pockets promote oil flow through the bearing and the formation of a lubricant film.

For grease lubricated applications, contact the SKF application engineering service.

Application examples

Planetary gear set

Planet bearings (→ **fig. 3**), which enable the planets to turn, are typically subjected to heavy radial loads. However, the magnitude of the load can change from heavy to either extremely heavy or very light in an instant. To operate reliably under these conditions, the outer ring raceway of the bearing is frequently integrated into the bore of the planet.

This integrated solution avoids ring creep, the primary cause of outer ring fractures. It also enables the use of larger planet bearings. The cage design of SKF high-capacity cylindrical roller bearings enables the bearing to accommodate higher speeds, generate less heat and avoid damage caused by roller smearing, when compared to a full complement bearing. The result: longer bearing service life in a planetary gear set.

Planetary gear set with different SKF high-capacity cylindrical roller bearings

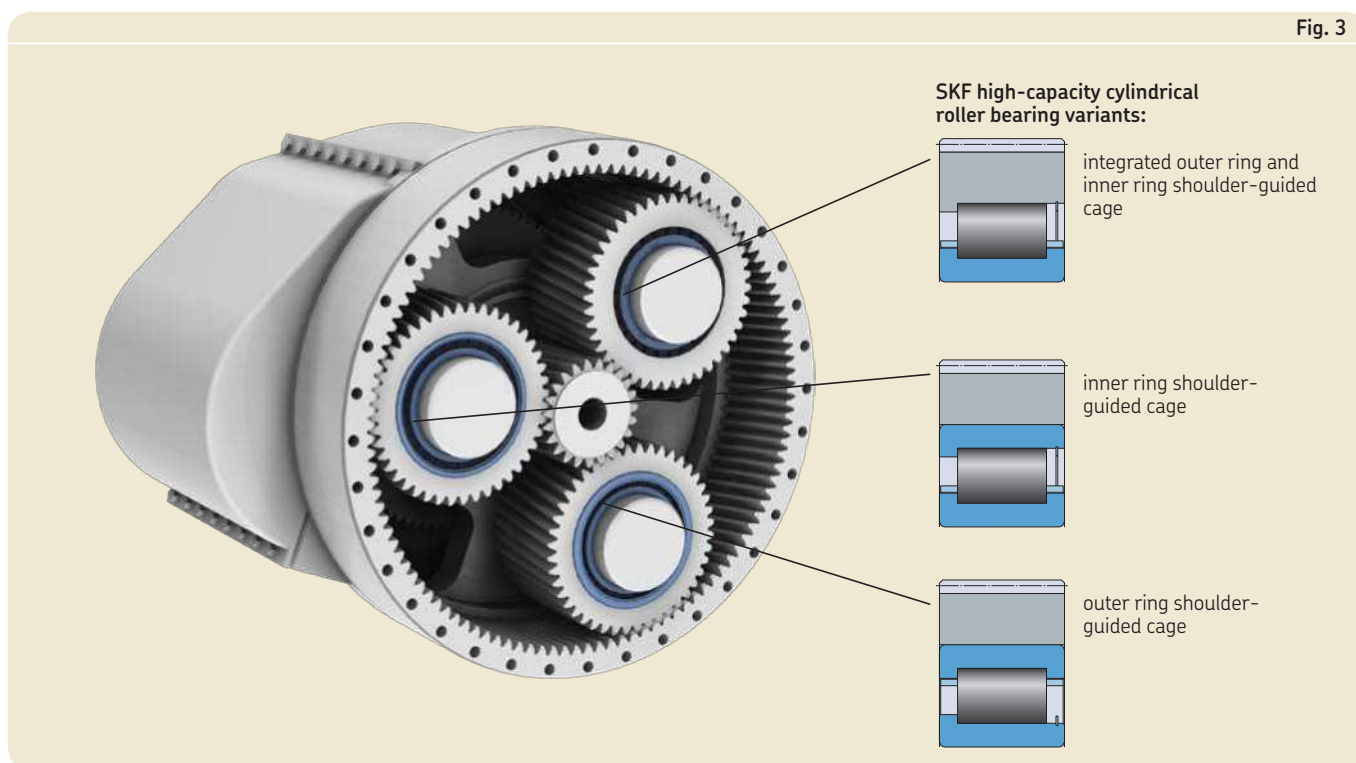

Fig. 3

Intermediate and output shafts

Intermediate and output shaft applications are considered to be high speed shafts. Due to the high speeds, full complement bearings are not an appropriate choice. Frequently, there are load conditions where the required minimum load for the bearings cannot be guaranteed. Here, an SKF high-capacity cylindrical roller bearing with an inner ring shoulder-guided steel cage (NCF design and designation suffix L4B) can significantly increase the service life of the bearings. These bearings are designed to improve sliding resistance and promote the formation of a lubricant film on all contact surfaces. (→ **fig. 4**) to minimize the risk of smearing damage resulting from roller sliding.

Light-load and high-speed applications

In lightly loaded high-speed applications, roller sliding and insufficient lubrication are frequent causes of premature bearing failure. In these applications, fully black oxidized SKF high-capacity cylindrical roller bearings with an inner ring shoulder-guided steel cage (NCF design and designation suffix L4B) can significantly increase the service life of the bearings. These bearings are designed to improve sliding resistance and promote the formation of a lubricant film on all contact surfaces.

In combination with low inertia of the roller set, bearings in the 22 dimension series provide the best solution to minimize the risk of skidding damage and avoid bearing damage.

Intermediate and output shafts with SKF high-capacity cylindrical roller bearings

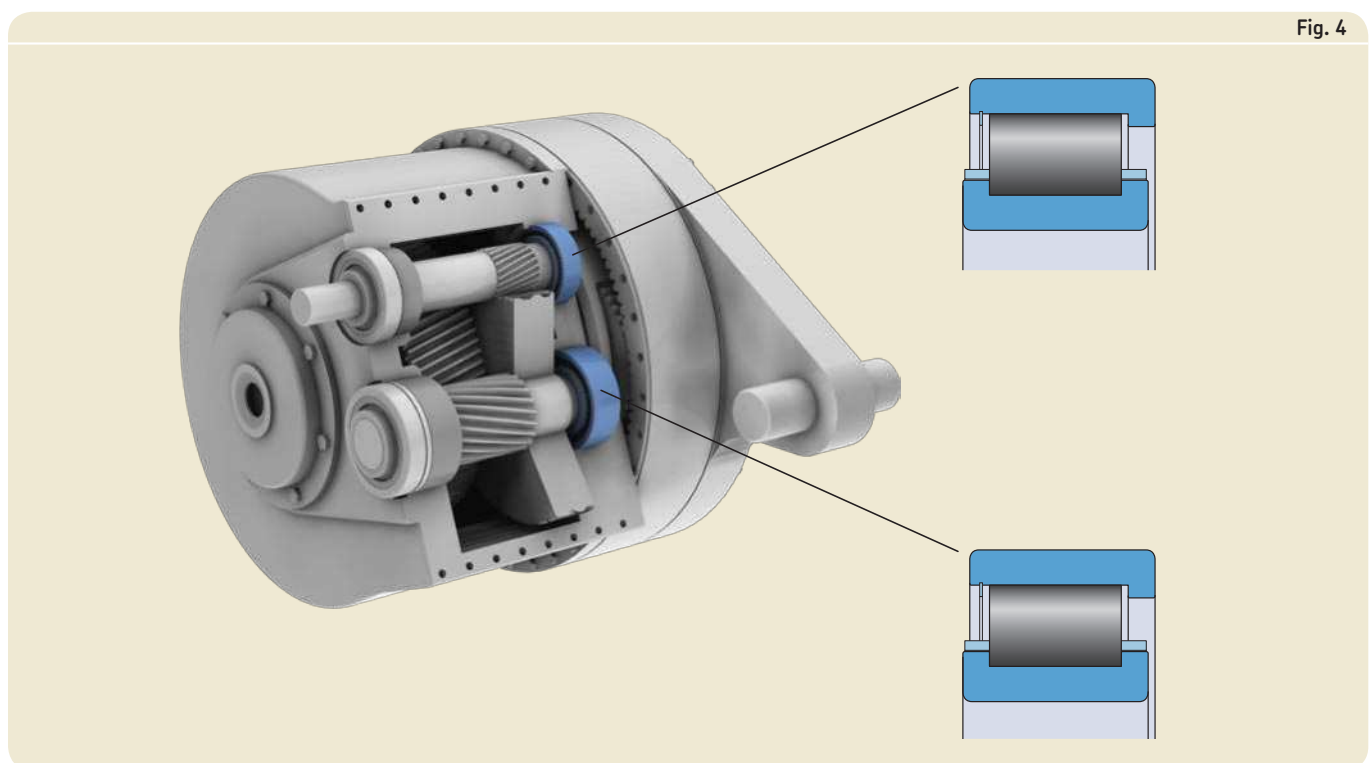

Mounting and dismounting

Due to the cage position above or below the roller pitch diameter, the cage cannot prevent the rollers from falling out when the inner and outer rings of the bearing are separated. A retaining ring mounted in a groove in the inner or outer ring keeps the bearing together. SKF recommends mounting high-capacity cylindrical roller bearings as a complete bearing, like a full complement cylindrical roller bearing, a spherical roller bearing or a deep groove ball bearing.

If mounting the inner and outer rings separately is necessary, use a mounting sleeve (→ **fig. 5**) or a retaining strap (→ **fig. 6**) to keep the rollers in place.

Locating and non-locating bearing position

SKF high-capacity cylindrical roller bearings can be non-locating or locating in one direction (→ **fig. 7**). Appropriate mounting is required to achieve the desired function.

Mounting for locating in one direction

SKF high-capacity cylindrical roller bearings can accommodate axial displacement of the inner ring relative to the outer ring in the direction of the retaining ring side. The bearing must be oriented correctly and the rings must be centred.

Mounting a non-locating bearing

SKF high-capacity cylindrical roller bearings can be used as non-locating bearings to accommodate axial displacement in both directions. The bearing rings have to be mounted with a certain offset relative to each other. The typical offset is half of the permissible axial displacement, which is listed in the product tables (parameter "s").

Mounting sleeve for an SKF high-capacity cylindrical roller bearing with an outer ring shoulder-guided cage

Fig. 5

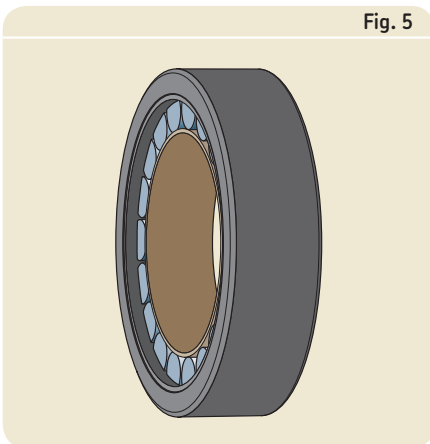

Retaining strap for an SKF high-capacity cylindrical roller bearing with an inner ring shoulder-guided cage

Fig. 6

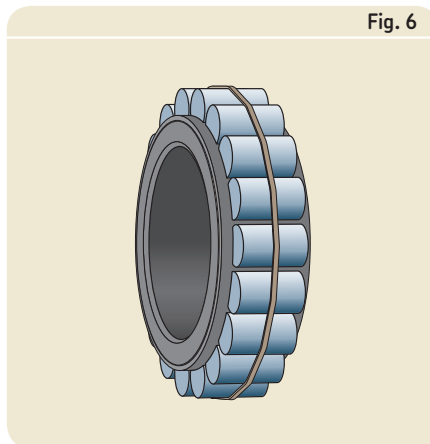
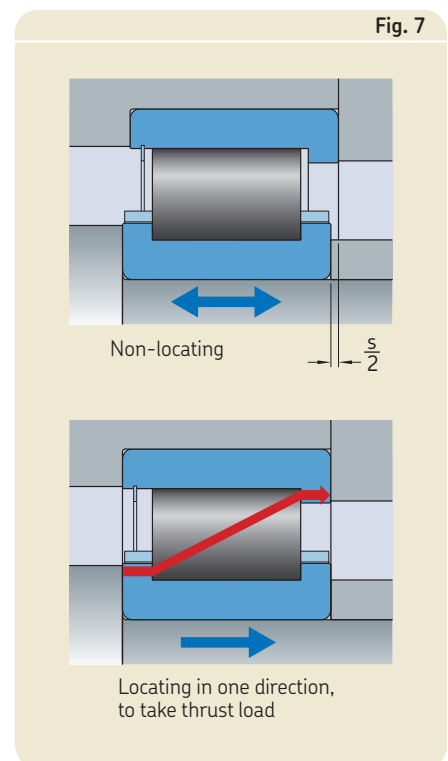

Fig. 7



Designs

Standard design

Standard SKF high-capacity cylindrical roller bearings (→ **fig. 8**) are equipped with an inner ring shoulder-guided steel cage (designation suffix JB). The cage is manganese phosphated. The rollers are black oxidized (designation suffix L5B).

When the outer raceway is integrated into the application, SKF high-capacity bearings can be supplied without an outer ring (→ **fig. 9**). Bearings without an outer ring are secured with a retaining strap to keep the rollers in place and protected with an elastic plastic mesh. They are identified by the designation prefix RN.

Variants

Bearings with an outer ring shoulder-guided cage

SKF high-capacity cylindrical roller bearings can be equipped with an outer ring shoulder-guided steel cage (designation suffix JA). For some sizes, the bearings contain one roller more than a same-sized bearing with an inner ring shoulder-guided JB cage.

When the inner raceway is integrated into the application, SKF high-capacity bearings can be supplied without an inner ring. Bearings without an inner ring are supplied with a sleeve to keep the rollers in place. They are identified by the designation prefix RNU.

Double row bearings

Double row SKF high-capacity cylindrical roller bearings can be supplied on request. They are based on double row full complement bearings (e.g. NNCF design). For additional information, contact the SKF application engineering service.

Matched bearing sets

SKF can supply sets of matched bearings. To match bearings, SKF combines bearings so that the difference in cross-section heights lies within a very small tolerance range. This reduced tolerance range is a precondition for equal load sharing between the bearings.

Sets of matched bearings are identified by a designation suffix (→ **fig. 10**):

- DR for a set of two bearings
- TR for a set of three bearings
- QR for a set of four bearings

The bearings in a matched set can be single row (e.g. NCF design) or double row (e.g. NNCF design) bearings.

SKF high-capacity cylindrical roller bearing with an inner ring shoulder-guided steel cage

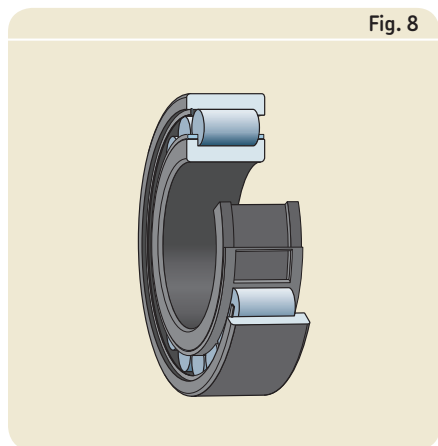

Fig. 8

SKF high-capacity cylindrical roller bearing without an outer ring

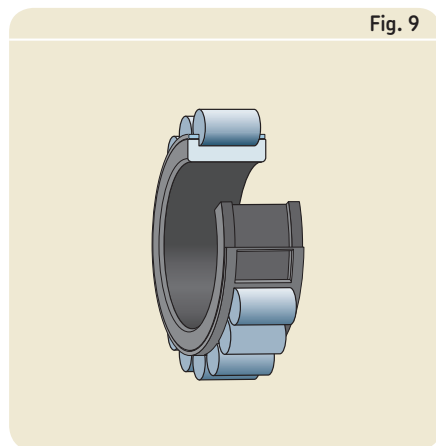
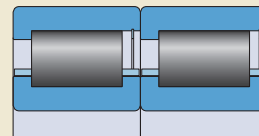

Fig. 9

Matched bearing sets

Fig. 10



Bearing set with two bearings, designation NCF .. ECJB/DR

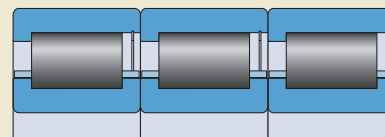

Bearing set with three bearings, designation NCF .. ECJB/TR

Bearing data – general

SKF Explorer bearings

SKF Explorer high-capacity cylindrical roller bearings are available in the 22 series, up to a 200 mm bore, and in the 23 series, up to a 150 mm bore as standard. In the 22 series with the bore diameter 220 mm and in the 23 series from bore diameter 160 to 240 mm, both conventional and SKF Explorer bearings are available. The SKF Explorer bearings in this range are identified by the designation suffix PEX.

Dimensions

The boundary dimensions of SKF high-capacity cylindrical roller bearings are in accordance with ISO 15:1998. The bearings are available in the 22 and 23 dimension series. Bearings in the 22 series have a bore diameter ranging from 140 to 220 mm. Bearings in the 23 dimension series have a bore diameter ranging from 130 to 240 mm. Other sizes or special dimensions are available on request.

Tolerances

SKF high-capacity cylindrical roller bearings are manufactured to Normal tolerances for dimensional accuracy and to P6 tolerances for running accuracy. The tolerances are in accordance with ISO 492:2002.

Radial internal clearance

SKF high-capacity cylindrical roller bearings are manufactured with Normal radial clearance as standard. Other radial clearance classes, e.g. C3 are available on request.

Axial displacement

SKF high-capacity cylindrical roller bearings can accommodate axial displacement of the shaft relative to the housing within certain limits. As the axial displacement takes place within the bearing and not between the bearing and shaft or housing bore, there is practically no increase in friction when the bearing rotates. Values for the permissible axial displacement from the normal position of one bearing ring relative to the other are listed in the product tables (parameter “s”).

If an SKF high-capacity cylindrical roller bearing is used as a non-locating bearing in both directions, the bearing rings must be mounted with an offset relative to each other (→ page 10). The required offset and the maximum movement from the centre position is half of the permissible axial displacement, s.

Misalignment

The ability of SKF high-capacity cylindrical roller bearings to accommodate angular misalignment of the inner ring relative to the outer ring is limited to 3 minutes of arc. This value applies to non-locating bearings, provided the position of the shaft and housing axes remain constant. When the bearings are used to locate the shaft axially, the value must be reduced as uneven flange loading can lead to increased wear and increases the risk of flange fracture. For additional information, contact the SKF application engineering service.

Operating temperature

SKF high-capacity cylindrical roller bearings undergo a special heat treatment that enables the bearings to accommodate temperatures up to 150 °C, provided the bearings are lubricated properly.

Minimum load

For satisfactory operation, SKF high-capacity cylindrical roller bearings must always be subjected to a given minimum load.

The requisite minimum load to be applied to SKF high-capacity cylindrical roller bearings can be estimated using

$$F_{rm} = k_r \left(6 + \frac{4n}{n_r} \right) \left(\frac{d_m}{100} \right)^2$$

where

F_{rm} = minimum radial load [kN]

k_r = minimum load factor

0,16 for bearings in the 22 series

0,20 for bearings in the 23 series

n = rotational speed [r/min]

n_r = reference speed [r/min]

d_m = bearing mean diameter [mm]
= 0,5 (d+D)

As shown in the section *Light-load test* (→ page 6), when operating below the recommended minimum load, the cage-slip of an SKF high-capacity cylindrical roller bearing with an inner ring shoulder-guided cage is significantly reduced compared to bearings with a standard cage.

Dynamic axial load carrying capacity

SKF high-capacity cylindrical roller bearings can support axial loads in one direction. Their axial load carrying capacity is primarily determined by the ability of the sliding surfaces of the roller end / flange contact to support loads. Factors having the greatest effect on this ability are the lubricant, operating temperature and the ability of the bearing to dissipate heat.

The dynamic axial load carrying capacity can be calculated as described in the *SKF General Catalogue* for single row cylindrical roller bearings. Calculations can be performed using the *SKF Interactive Engineering catalogue*, available online at www.skf.com.

To minimize the risk of flange fracture, the constantly acting axial load applied to the bearings should never exceed

$$F_{a \max} = 0,0035 D^{1,7}$$

When acting only occasionally and for brief periods, the axial load applied to the bearings should never exceed

$$F_{a \max} = 0,0085 D^{1,7}$$

where

$F_{a \max}$ = maximum constantly or occasionally acting axial load [kN]

D = bearing outside diameter [mm]

For additional information about dynamic axial load carrying capacity, contact the SKF application engineering service.

Equivalent dynamic bearing load

For non-locating bearings

$$P = F_r$$

where

P = equivalent dynamic bearing load [kN]

If an SKF high-capacity bearing is used to locate the shaft in one direction, the equivalent dynamic bearing load should be calculated using

$$P = F_r \quad \text{when } F_a/F_r \leq 0,3$$
$$P = 0,92 F_r + 0,4 F_a \quad \text{when } F_a/F_r > 0,3$$

Since axially loaded cylindrical roller bearings only operate satisfactorily when they are subjected to a simultaneously acting radial load, the ratio F_a/F_r should not exceed 0,5.

Equivalent static bearing load

$$P_0 = F_r$$

where

P_0 = equivalent static bearing load [kN]

Supplementary designations

In addition to the designation suffixes that are listed in the *SKF General Catalogue*, the following designation suffixes are relevant for SKF high-capacity cylindrical roller bearings:

- JB** One-piece window-type steel cage, inner ring shoulder-guided
- JA** One-piece window-type steel cage, outer ring shoulder-guided
- L4B** Rollers and bearing rings black oxidized
- L5B** Rollers black oxidized
- L7B** Rollers and inner ring black oxidized
- PEX** SKF Explorer bearing, used only when same-sized conventional and SKF Explorer bearings are available
- DR** Bearing set consisting of two matched bearings
- TR** Bearing set consisting of three matched bearings
- QR** Bearing set consisting of four matched bearings

For additional information, refer to the *SKF General Catalogue* or the *SKF Interactive Engineering Catalogue*, available online at www.skf.com.

High-capacity cylindrical roller bearings
d 130 – 240 mm

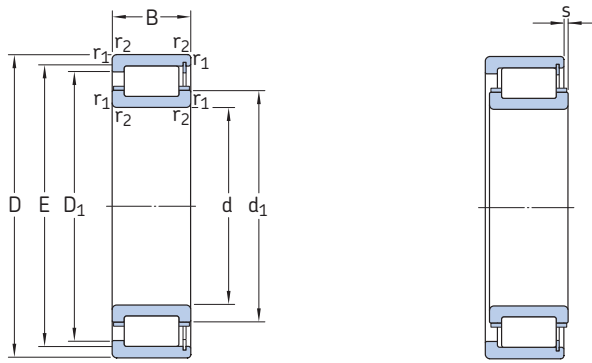

Principal dimensions			Basic load ratings		Fatigue load limit	Speed ratings		Mass	Designations
d	D	B	dynamic	static		Reference speed	Limiting speed		
			C	C ₀	P _u				
mm			kN		kN	r/min		kg	–
130	280	93	1 120	1 340	146	2 400	3 400	29,0	* NCF 2326 ECJB
140	250	68	680	880	96,5	2 800	3 600	14,5	* NCF 2228 ECJB
	300	102	1 250	1 530	163	2 400	3 200	35,5	* NCF 2328 ECJB
150	270	73	780	1 040	112	2 600	3 400	18,0	* NCF 2230 ECJB
	320	108	1 430	1 760	183	2 200	3 000	43,5	* NCF 2330 ECJB
160	290	80	980	1 270	134	2 400	3 000	23,5	* NCF 2232 ECJB
	340	114	1 400	2 000	196	1 800	2 800	50,5	NCF 2332 ECJB
	340	114	1 600	2 000	196	2 000	2 800	50,5	* NCF 2332 ECJB/PEX
170	310	86	1 160	1 530	156	2 200	2 800	28,0	* NCF 2234 ECJB
	360	120	1 540	2 200	216	1 700	2 600	58,5	NCF 2334 ECJB
	360	120	1 760	2 200	216	1 900	2 600	58,5	* NCF 2334 ECJB/PEX
180	320	86	1 200	1 600	166	2 200	2 800	30,0	* NCF 2236 ECJB
	380	126	1 720	2 400	232	1 600	2 400	67,5	NCF 2336 ECJB
	380	126	1 960	2 400	232	1 800	2 400	67,5	* NCF 2336 ECJB/PEX
190	340	92	1 320	1 760	180	2 000	2 600	36,5	* NCF 2238 ECJB
	400	132	1 940	2 750	255	1 500	2 200	78,0	NCF 2338 ECJB
	400	132	2 240	2 750	255	1 700	2 200	78,0	* NCF 2338 ECJB/PEX
200	360	98	1 460	2 000	200	1 900	2 400	43,0	* NCF 2240 ECJB
	420	138	2 200	3 200	300	1 400	2 200	91,5	NCF 2340 ECJB
	420	138	2 550	3 200	300	1 600	2 200	91,5	* NCF 2340 ECJB/PEX
220	400	108	1 760	2 600	240	1 600	2 200	58,5	NCF 2244 ECJB
	400	108	2 000	2 600	240	1 700	2 200	58,5	* NCF 2244 ECJB/PEX
	460	145	2 510	3 650	335	1 300	2 000	113,4	NCF 2344 ECJB
	460	145	2 900	3 650	335	1 400	2 000	113,4	* NCF 2344 ECJB/PEX
240	500	155	2 750	4 000	345	1 200	1 800	146,5	NCF 2348 ECJB
	500	155	3 150	4 000	345	1 300	1 800	146,5	* NCF 2348 ECJB/PEX

* SKF Explorer bearing

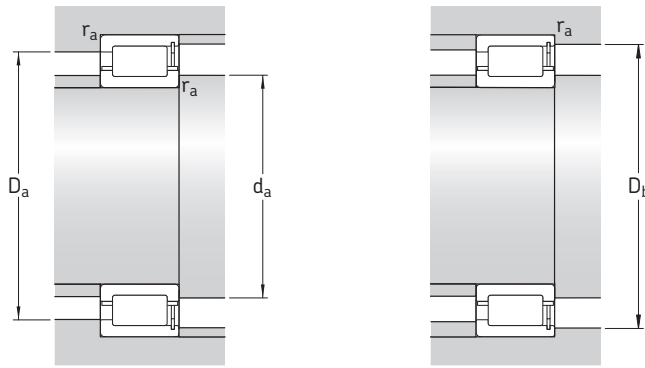

Dimensions						Abutment and fillet dimensions				Abutment dimensions for axial loaded bearings	
d	d ₁ ~	D ₁ ~	E	r _{1,2} min	s ¹⁾	d _a min	D _a max	D _b max	r _a max	d _a	D _a
mm						mm				mm	
130	182	234	247	4	6,5	147	263	263	3	175	241
140	180 196	216 251	225 264	3 4	4,0 7,3	154 157	236 283	236 283	2,5 3	174 188	220 257
150	193 210	229 268	242 283	3 4	4,4 7,9	164 167	256 303	256 303	2,5 3	188 201	235 276
160	206 222 222	250 285 285	261 300 300	3 4 4	4,1 8,3 8,3	174 177 177	276 323 323	276 323 323	2,5 3 3	199 213 213	256 292 292
170	219 235 235	269 299 299	281 316 316	4 4 4	3,8 7,5 7,5	187 187 187	293 343 343	293 343 343	3 3 3	212 225 225	275 307 307
180	229 248 248	279 320 320	291 339 339	4 4 4	3,8 7,9 7,9	197 197 197	303 363 363	303 363 363	3 3 3	222 237 237	285 329 329
190	243 262 262	295 341 341	308 360 360	4 5 5	4,5 7,1 7,1	207 210 210	323 380 380	323 380 380	3 4 4	236 251 251	302 351 351
200	256 276 276	312 356 356	325 377 377	4 5 5	4,6 7,1 7,1	217 220 220	343 400 400	343 400 400	3 4 4	249 264 264	318 367 367
220	279 279 302 302	349 349 392 392	367 367 413 413	4 4 5 5	7,1 7,1 7,8 7,8	237 237 240 240	383 383 440 440	383 383 440 440	3 3 4 4	269 269 290 290	358 358 402 402
240	327 327	426 426	449 449	5 5	7,7 7,7	260 260	480 480	480 480	4 4	313 313	437 437

¹⁾ Permissible axial displacement of one bearing ring relative to the other

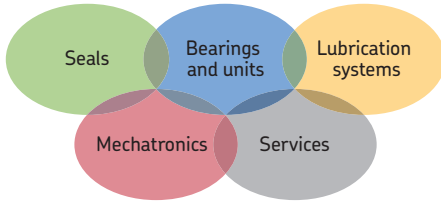

The Power of Knowledge Engineering

Drawing on five areas of competence and application-specific expertise amassed over more than 100 years, SKF brings innovative solutions to OEMs and production facilities in every major industry worldwide. These five competence areas include bearings and units, seals, lubrication systems, mechatronics (combining mechanics and electronics into intelligent systems), and a wide range of services, from 3-D computer modelling to advanced condition monitoring and reliability and asset management systems. A global presence provides SKF customers uniform quality standards and worldwide product availability.

© SKF and SKF EXPLORER are registered trademarks of the SKF Group.

© SKF Group 2010

The contents of this publication are the copyright of the publisher and may not be reproduced (even extracts) unless prior written permission is granted. Every care has been taken to ensure the accuracy of the information contained in this publication but no liability can be accepted for any loss or damage whether direct, indirect or consequential arising out of the use of the information contained herein.

PUB BU/P2 06894 EN · March 2010

Printed in Sweden on environmentally friendly paper.

