

Sockets

Electric Plug and Socket Connectors

For pressure switches, level switches, flow sensors, directional control valves and filters



Electric Plug and Socket Connectors

Electric plugs or sockets are required for the actuation of various models of hydraulic equipment used in the field of central lubrication technology and for the evaluation of switching signals.

Product overview

Overview coupler sockets		Application										
Order No.	Standard design / type	Pressure switch	Flow sensor	Filter monitor	Lubricant level switch	Piston distributor	Oil-streak sensor	Flow monitor	Directional control valve	Cycle switch	Pumps (KFG)	Page
2360-00000316 straight 2360-00000317 angled	DIN EN61076-2-101 4-pole, M12x1	•	•	•	•	•	•	•		•		3
24-1882-2076 straight	DIN EN60947-5-2 DIN EN61076-2-101 5-pole, M12x1								•			3
179-990-381 straight 179-990-382 angled	DIN EN61076-2-101 3-pole, M12x1 (with integrally extruded line)	•	•	•	•	•	•	•		•		4
179-990-600 straight 179-990-601 angled 179-990-603 straight	IEC60228, DIN13802, DIN IEC60757, IEC60332-2 4-pole, M12x1 (with integrally extruded line)	•	•	•	•	•	•	•		•		5
179-990-033 179-990-147 179-990-657	DIN EN 175301-803 -A/ ISO 4400	•	•	•	•							6
179-990-110+410 179-990-111+924	DIN EN 175301-803 -A/ ISO 4400							•				7
179-990-416	DIN EN 175301-803 -A/ ISO 4400 (with integrally extruded line)								•			8

Overview circular connectors and device adapters		Application										
Order No.	Standard design / type	Pressure switch	Flow sensor	Filter monitor	Lubricant level switch	Piston distributor	Oil-streak sensor	Flow monitor	Directional control valve	Cycle switch	Pumps (KFG)	Page
2360-00000314 straight 2360-00000315 angled	DIN EN61076-2-101 4-pole, M12x1										•	9
179-990-458 179-990-461 179-990-776	DIN EN 175301-803 A/M12x1								•			10

Circular plug M12×1 acc. to DIN EN61076-2-101

Socket contacts

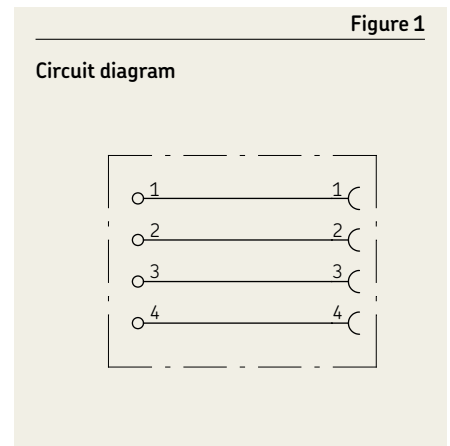
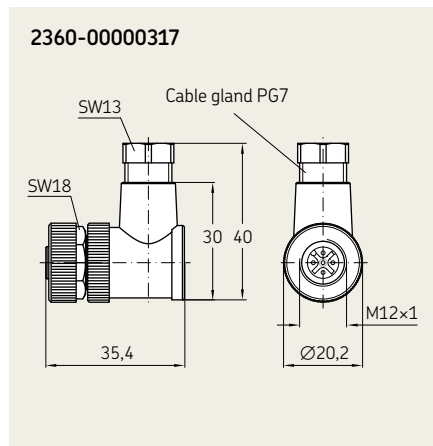
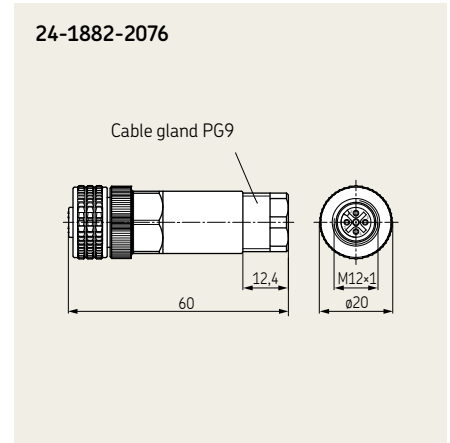
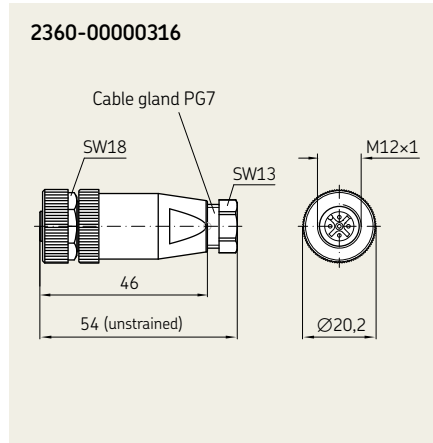

Technical data	2360-00000316 / 2360-00000317	24-1882-2076
Order No.	2360-00000316 / 2360-00000317	24-1882-2076
Pole	4	5
Conductor cross section max.	4x 0.75 mm ²	5x 0.75 mm ²
Line diameter	4 to 6 mm	6 to 8 mm
Max. rated operating voltage	250 V AC/DC	60 V AC/DC
Max. operating current	4 A	4 A
Housing material	PA, black	PA, black
Type of terminal	Screw terminal	Screw terminal
IP enclosure DIN60529	IP 68 (installed)	IP 67 (installed)
Temperature range	-25 to +85 °C	-25 to +90 °C
Approval	UL	-
Color coding	→ Figure 1	→ Figure 2
Contact assignments	→ Figure 3	→ Figure 4

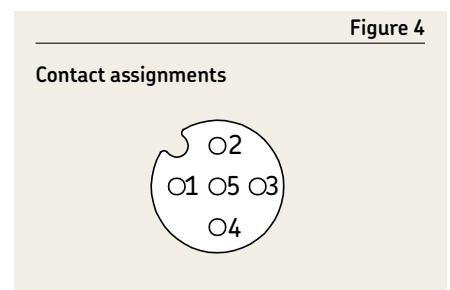
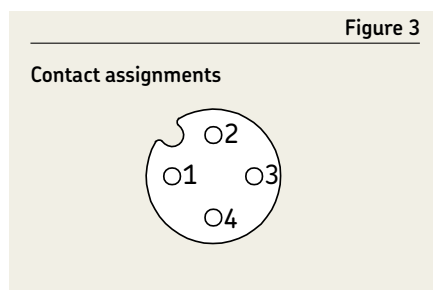
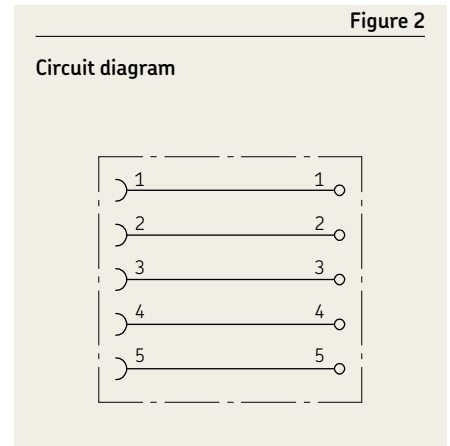

Circular plug M12×1 acc. to DIN EN61076-2-101

with integrally extruded line, socket contacts

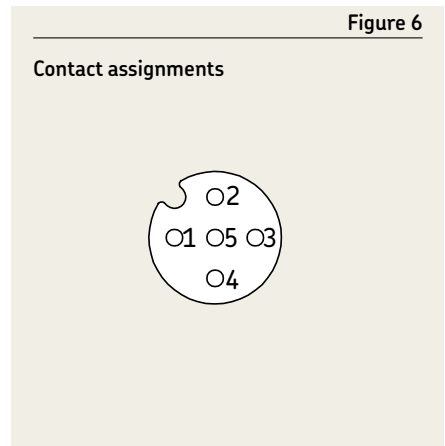
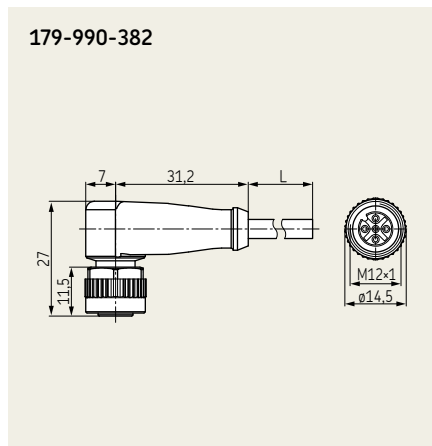
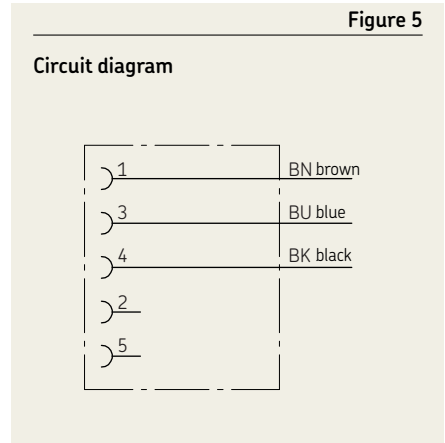
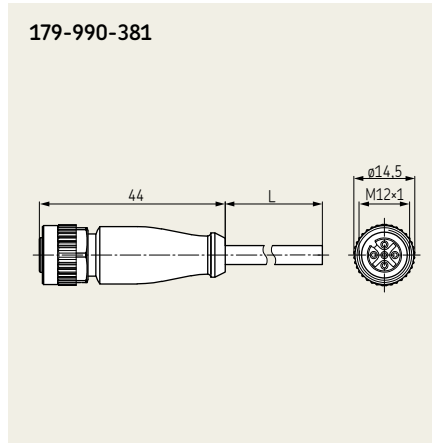

Technical data

Order No.	179-990-381 / 179-990-382
Pole	3
Conductor cross section max.	3x 0.34 mm ²
Line diameter /length	4.5 mm / 5 m
Max. rated operating voltage	250 V AC/DC
Max. operating current	4 A
Housing material	PUR, black
IP enclosure DIN60529	IP 68 (installed)
Temperature range	-50 to +90 °C
Approval	UL
Color coding	→ Figure 5
Contact assignments	→ Figure 6

Circular plug M12×1 acc. to IEC60228,

DIN13802, DIN IEC60757, IEC60332-2; with integrally extruded line, socket contacts

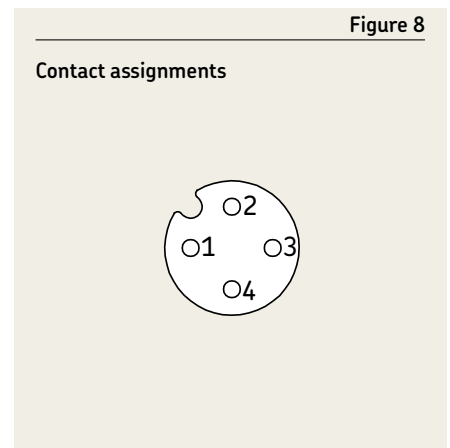
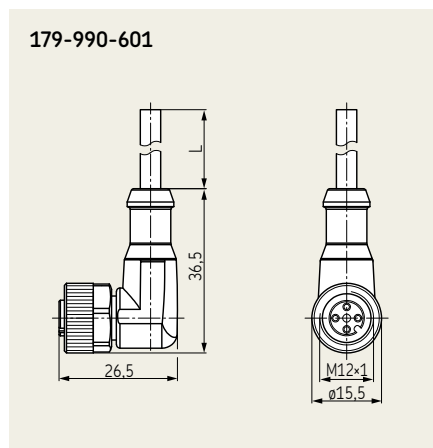
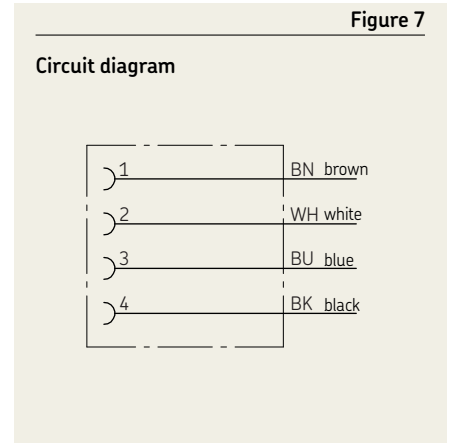
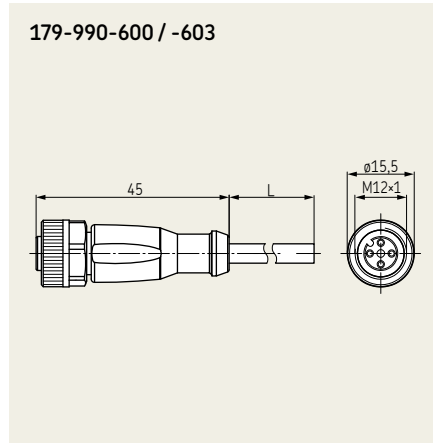

Technical data				
Order No.	179-990-600	179-990-603	179-990-601	
Pole	4	4	4	
Conductor cross section max.	4x 0.34 mm ²	4x 0.34 mm ²	4x 0.34 mm ²	
Line diameter / length	4.9 mm / 5 m	4.9 mm / 10 m	4.9 mm / 5 m	
Max. rated operating voltage	250 V AC/300 V DC	250 V AC/300 V DC	250 V AC/300 V DC	
Max. operating current	4 A	4 A	4 A	
Housing material	TPU, orange	TPU, orange	TPU, orange	
Line material	PUR, black	PUR, black	PUR, black	
IP enclosure DIN60529	IP 68 (installed)	IP 68 (installed)	IP 68 (installed)	
Temperature range	-25 to +90 °C	-25 to +90 °C	-25 to +90 °C	
Approval	UL	UL	UL	
Color coding	→ Figure 7	→ Figure 7	→ Figure 7	
Contact assignments	→ Figure 8	→ Figure 8	→ Figure 8	

Rectangular connectors acc. to DIN EN175301-803-A

Form A, socket contacts, supplied with flat packing and fixing screw

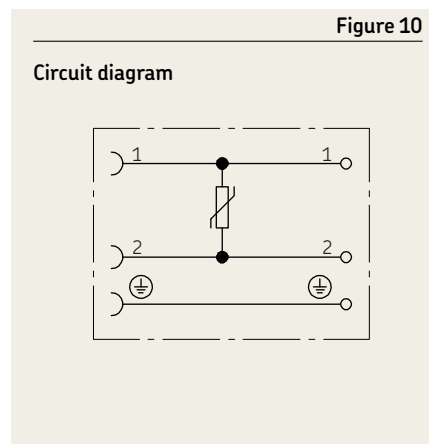
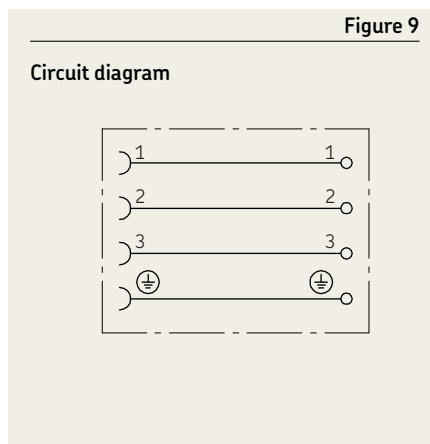
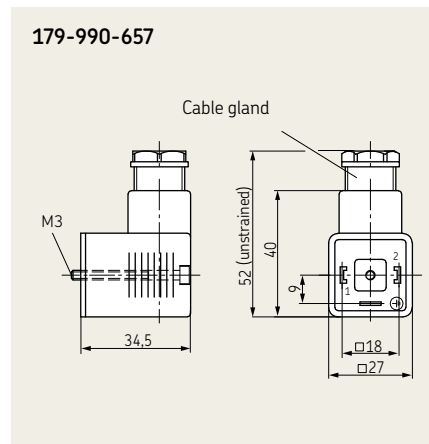
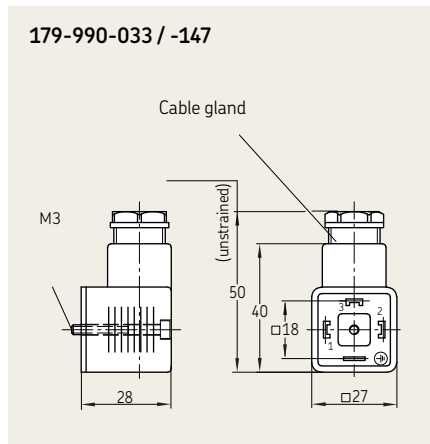

Technical data	179-990-033	179-990-147	179-990-657
Order No.	179-990-033	179-990-147	179-990-657
Version	Insert rotatable 4x 90°	Insert rotatable 4x 90°	Insert rotatable 4x 90°
Pole	3+PE	3+PE	2+PE
Conductor cross section max.	4x 1.5 mm ²	4x 1.5 mm ²	3x 1.5 mm ²
Line diameter	6 to 10 mm	6 to 8 mm	6 to 9 mm
Cable gland	M16x1.5	PG9	PG11
Max. rated operating voltage	250 VAC/DC	250 VAC/DC	120 VAC/DC
Max. operating current	10 A	10 A	10 A
Housing material	PA, black	PA, black	PA, black
Seal	attached, NBR	attached, NBR	attached, Silikon
Type of terminal	Screw terminal	Screw terminal	Screw terminal
IP enclosure	IP 65 (installed)	IP 65 (installed)	IP 65 (installed)
Temperature range	-40 to +100 °C	-30 to +120 °C	-40 to +80 °C
Approval	UL/CSA/ESTI+	UL/CSA/ESTI+	-
Color coding	→ Figure 9	→ Figure 9	→ Figure 10

Rectangular connectors acc. to DIN EN175301-803-A

Form A, socket contacts, supplied with fixing screw

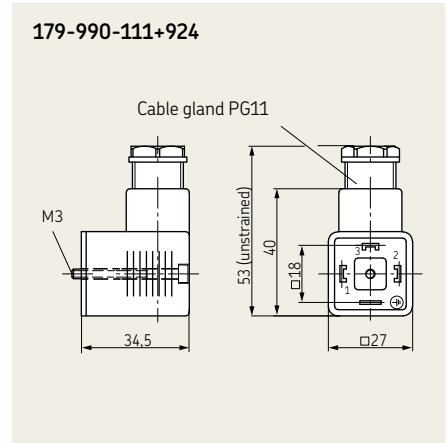
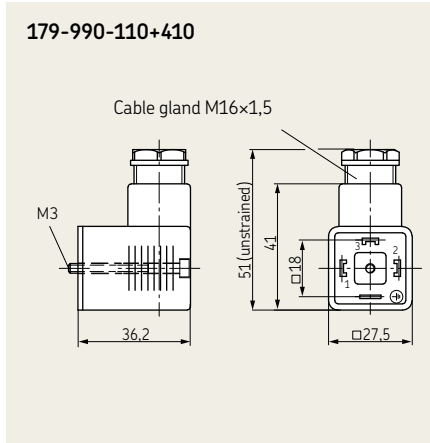

Figure 11

Circuit diagram

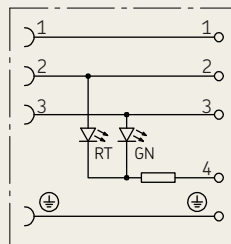
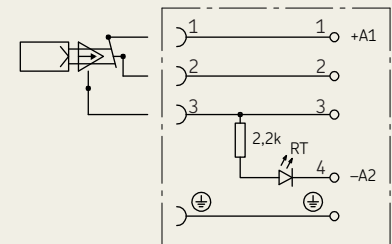

Figure 12

Circuit diagram



Technical data

Order No.	179-990-110+410	179-990-111+924
Version	Insert rotatable 4x 90°	Insert rotatable 4x 90°
Pole	3+PE	3+PE
Conductor cross section max.	4x 1.5 mm ²	4x 1.5 mm ²
Line diameter	4,5 to 10 mm	8 to 10 mm
Max. rated operating voltage	250 V DC	24 V DC
Max. operating current	8 A	10 A
Operating display	LED red / green, each <5 mA	LED red, <20 mA
Housing material	PA 6 GF, transparent/black	PA, transparent
Seal	NBR	attached, NBR
Type of terminal	Screw terminal	Screw terminal
IP enclosure DIN60529	IP 65 (installed)	IP 65 (installed)
Temperature range	-40 to +90 °C	-25 to +85 °C
Approval	UL	-
Color coding	→ Figure 11	→ Figure 12

Rectangular connectors acc. to DIN EN175301-803-A

Form A, socket contacts, supplied with flat packing and fixing screw

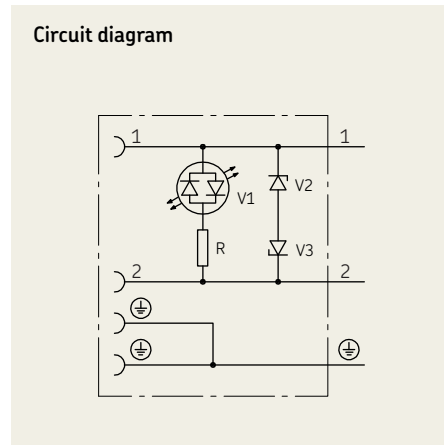
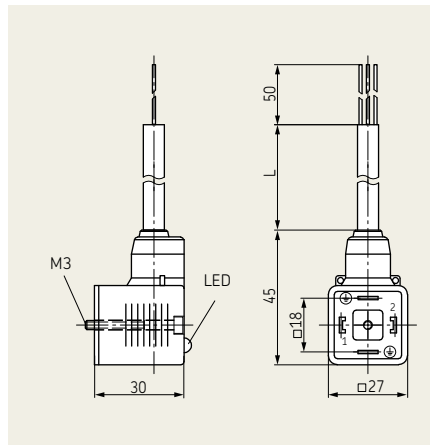

Technical data

Order No.	179-990-416
Pole	2+PE
Conductor cross section max.	3x 0.75 mm ²
Line diameter /length	5,9 mm / 3 m
Rated voltage	24 V AC/DC
Max. rated operating voltage	30 V AC/DC
Max. operating current	4 A
Operating display	LED yellow, <12 mA
Housing material	PBT, black
Seal	permanently connected, TPU
Type of terminal	Screw terminal
IP enclosure DIN60529	IP 67 (installed)
Temperature range	-25 to +85 °C

Circular plug M12x1 acc. to DIN EN61076-2-101

Plug contacts

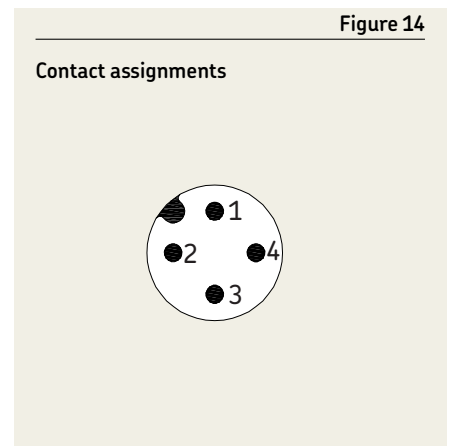
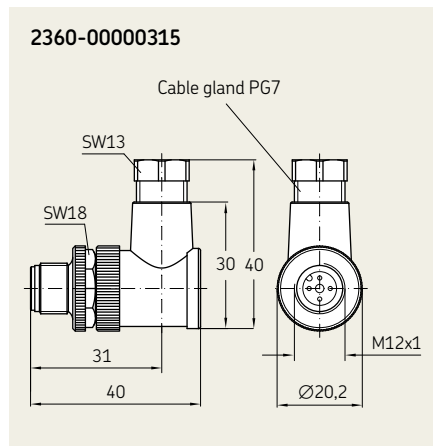
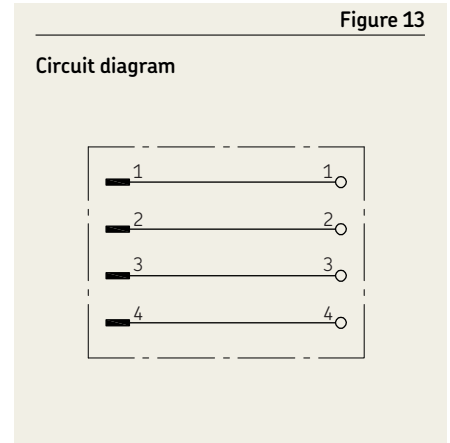
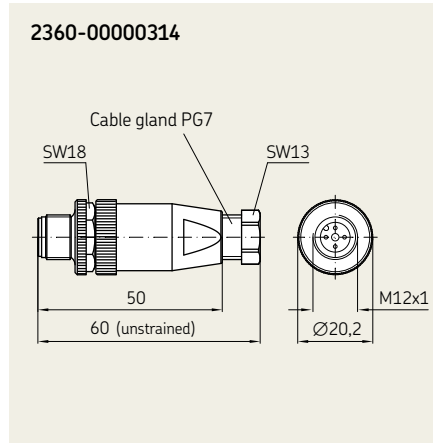

Technical data

Order No.	2360-00000314 / 2360-00000315
Pole	4
Conductor cross section max.	4x 0.75 mm ²
Line diameter	4 to 6 mm
Max. rated operating voltage	250 VAC/DC
Max. operating current	4 A
Housing material	PA, black
Seal	FPM
Type of terminal	Screw terminal
IP enclosure DIN60529	IP 68 (installed)
Temperature range	-25 to +85 °C
Approval	UL
Color coding	→ Figure 13
Contact assignments	→ Figure 14

Adapter plug acc. to DIN EN175301-803-A / M12x1

Form A, supplied with flat packing and fixing screw

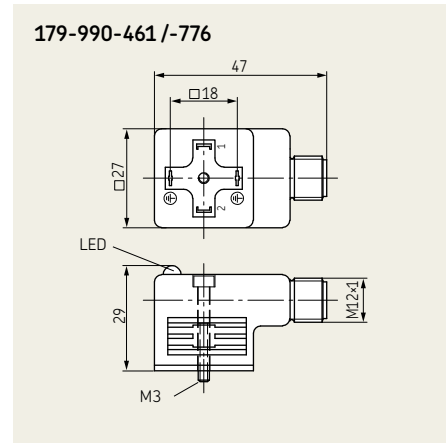
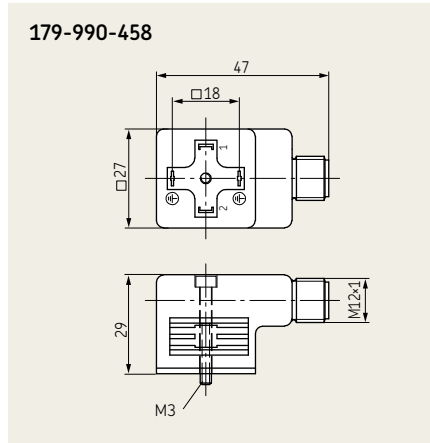

Figure 15

Circuit diagram

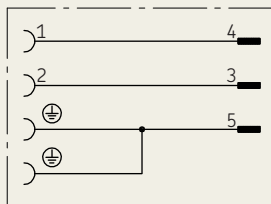

Figure 16

Circuit diagram

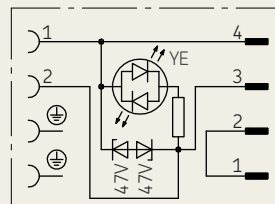
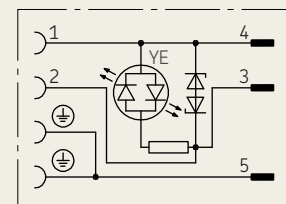

Figure 17

Circuit diagram



Technical data

Order No.	179-990-458	179-990-461	179-990-776
Pole	2+PE (coupler socket) 2+PE (M12x1 plug)	2 (coupler socket) 4 (M12x1 plug)	2+PE (coupler socket) 2+PE (M12x1 plug)
Rated voltage	—	—	24 VAC/DC
Max. rated operating voltage	110 VAC/DC	24 VAC/DC	28.8 V AC / 30 V DC
Max. operating current	4 A	4 A	4 A
Operating display	—	LED yellow, <15 mA	LED yellow, <12 mA
Housing material	PBT, black	PBT, black	PBT, black
Seal	TPU, permanently connected	TPU, attached	TPU, permanently connected
IP enclosure DIN60529	IP 67 (installed)	IP 65 (installed)	IP 67 (installed)
Temperature range	-25 to +85 °C	-25 to +90 °C	-25 to +90 °C
Approval	CSA	—	CSA
Color coding	→ Figure 15	→ Figure 16	→ Figure 17
Contact assignments	→ Figure 18	→ Figure 19	→ Figure 18

Figure 18

Contact assignments

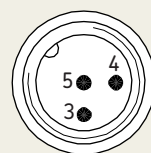
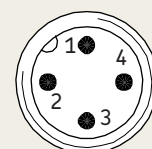

Figure 19

Contact assignments





Important information on product usage

SKF and Lincoln lubrication systems or their components are not approved for use with gases, liquefied gases, pressurized gases in solution and fluids with a vapor pressure exceeding normal atmospheric pressure (1 013 mbar) by more than 0,5 bar at their maximum permissible temperature.



skf.com | skf.com/lubrication

© SKF is a registered trademark of the SKF Group.

© SKF Group 2022

The contents of this publication are the copyright of the publisher and may not be reproduced (even extracts) unless prior written permission is granted. Every care has been taken to ensure the accuracy of the information contained in this publication but no liability can be accepted for any loss or damage whether direct, indirect or consequential arising out of the use of the information contained herein.

PUB LS/P2 17095 EN · 1-1730-DE · March 2022