

Control Units

for Single-Line Systems



The control units described in this leaflet are used for time- or pulse-dependent control of intermittently operated, single-line central lubrication systems with progressive feeders.

The overview shows the available control units for single-line systems together with the scope of their functions (see page 2).

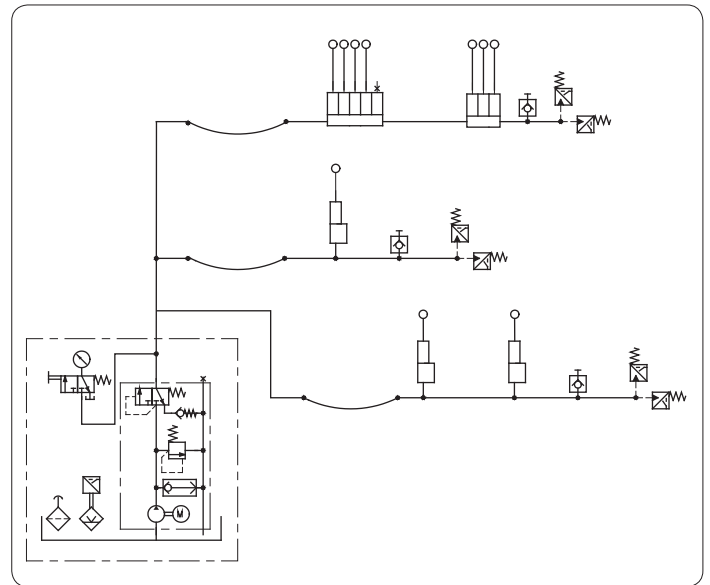

Function

The task of the control units is to trigger lubrication at certain intervals. The units also have a number of functions needed to control and monitor the lubrication system. The extent of these functions depends on the type of unit.

Overview of control units for single-line systems

Designation	Brief description
EXZT2A02	Pulse generator/counter with adjustable interval time, interval time extension, monitoring of pressure build-up and relief as well as lubricant level monitoring
EXZT2A05	Pulse generator/counter with adjustable interval time, interval time extension, monitoring of pressure build-up, pulse monitoring and lubricant level monitoring
EXZT2A07	Pulse generator/counter with adjustable interval time, interval time extension, monitoring of pressure build-up, lubricant level monitoring and early warning of critical lubricant levels
IGZ36-20	Pulse generator/counter with adjustable interval time, monitoring of pressure build-up and relief as well as adjustable delay time
IGZ36-20-S6	Like the IGZ36-20, lubricant-level monitoring with NC contact (wire break monitoring)
IGZ38-30	Pulse generator/counter with adjustable interval time and monitoring of pressure build-up, lubricant-level monitoring with NC contact (wire break monitoring)
IGZ38-30-S1	Like the IGZ38-30, lubricant-level monitoring with NO contact
IGZ51-20-S3	Pulse generator/counter with adjustable interval time, interval time extension, monitoring of pressure build-up and relief, adjustable delay time as well as activatable power-failure memory

Our control units conform to generally applicable standards.

With all the units listed above, it is possible to select NC or NO contacts for each individual input.

The lubrication cycle

A lubrication cycle consists of the contact time (lubrication routine) and the interval time (TP).

The interval time

The interval time is the time between two contact times. The length of the interval can basically be set in two ways, thus resulting in two different modes of operation (BA) for the control units (pulse generator and pulse counter). The mode of operation can be set on the unit by hand.

Interval time extension

With some units, it is possible to use input I3 to stop and enable the interval routine in the pulse-generator mode. The interval routine remains interrupted while the power is on.

Pulse generator mode

In this mode, the length of the interval is determined by the unit itself as the unit starts a contact time at the intervals specified by the operator.

Pulse counter mode

In this mode, the interval time is determined by the machine, which sends pulses to the control unit while it is in operation. The pulses received via the machine contact (MK or MKPV) are counted by the control unit and lubrication triggered after a preset number of pulses. The number of pulses to be counted can be specified by the operator.

Pulse monitoring

In the case of units with pulse monitoring (in the pulse counter mode only), not only the machine contact, MK or MKPV, but also a second machine contact, MKUe, is used. Both inputs are alternately queried. If no pulse is received via contact MKUe between two pulses arriving at contact MK/MKPV, a fault signal is emitted.

The contact time

After completion of the interval time, the control unit initiates the lubrication routine, which is also called the contact time. The contact time consists of the monitoring time (TU) and the pump delay time (TN).

Monitoring of pressure build-up

In the course of the contact time, the pump motor is first started, which builds up the pressure required for lubrication. This procedure is monitored by a pressure switch (DS). The respective pressure has to build up within the monitoring time, or the pump will switch off and a fault signal will be emitted.

Pressure build-up monitoring can be dispensed with by jumping terminals "+" and I2. In that case, the unit works with a contact time that is the same as the pump delay time.

Monitoring time TU

The monitoring time is a time window for the pressure build-up by the pump. If the necessary pressure is reached within the monitoring time, the latter is terminated. The pump delay time is then started.

As a rule, the monitoring time is fixed and cannot be changed by the operator.

Pump delay time

The pump delay time is a period of time in which the pump continues running after the necessary pressure is reached in the lubricant lines. This takes place into reliably supply lubricant to all the lube points in very large central lubrication systems.

Pump runtime limitation

The pump runtime (TL) is basically limited by the monitoring time.

Monitoring of pressure relief

Pressure relief is monitored by some units with the help of a second pressure switch (DS2) that is queried at the end of the interval time. If the pressure switch has not yet closed or opened by this time, a fault signal is emitted.

Monitoring of lubricant level

The control unit uses a level switch (WS) to monitor not only the pressure build-up but also the level of lubricant in the reservoir. This switch can either be an NC or NO contact, which has to be taken into account when selecting a control unit.

As soon as the reservoir drops below the minimum level, the sequence of functions in the lubrication system is stopped and a fault signal emitted.

Control Units for Single-Line Systems

If the level switch is the NC type, the signal cables leading to the level switch are monitored at the same time for wire breaks.

Early warning of critical lubricant level

Some units in this group are outfitted with an early lubricant level warning. If the level of lubricant in the reservoir drops to "Reserve", the early warning contact of the level switch (WS_V) opens. Relay d3 picks up and signals an early warning; the remaining functions are not influenced, i.e. the unit remains in operating readiness and the sequence of functions continues.

Automatic lubricant topping-up

Two lubricant level switches (WS_L and WS_H) can be connected to some units in order to control the automatic topping up of lubricant. If the level of lubricant in the reservoir drops below the minimum level, relay d3 actuates a valve or a pump that keeps on topping up new lubricant until the maximum level is reached. If the automatic topping up of lubricant fails, i.e. the lubricant drops below the critical level for an extended period of time, a fault signal is emitted.

Power-failure memory (EEPROM)

If the power for the control unit is interrupted, the power-failure memory stores important data like the remaining interval time or error messages. That means, depending on the type of unit, that the functional sequence can be continued and no messages will be lost the next time the unit is powered up.

Operation

Powering up

The unit is powered up by switching on the operating voltage. If the proper voltage is applied, the green power LED will light up.

The power must be switched on and off rapidly.

Prelubrication

Prelubrication is triggered every time the unit is switched on (exception: units with a power-failure memory). The pump motor is switched on and fault signal relay d2 is energized. Prelubrication proceeds like a normal contact time.

Interval time

After prelubrication is completed, relay d1 is deenergized, which in turn switches off the

motor. The value set for the interval time is then read and the interval routine started. In the further sequence of operations, the contact time and interval alternate with each other.

Contact time (lubrication routine)

The contact time is started after the interval time elapses. It is comprised of the time until the pressure builds up and the delay time. When the contact time begins, relay d1 is energized, thus switching on the pump motor. As soon as the requisite pressure is reached, the monitoring time is terminated and the pump delay time started. A new interval time begins at the end of the delay time.

Relay d2 in normal operation

When the power is on and there have been no malfunctions, relay d2 is energized.

Intermediate lubrication

Intermediate lubrication can be triggered by briefly pressing the  button during the interval. Intermediate lubrication follows the same routine as that of normal contact time.

Switching off

The unit is switched off by disconnecting it from the power.

Recovery time

After the unit is switched off, it has to remain off for a certain amount of time so that all the internal voltages are allowed to de-energize.

Changing parameters and the mode of operation

A change in the mode of operation does not take effect until the unit has been switched off and then on. A change in parameters like, for instance, the interval time, takes effect when the next interval begins.

Fault displays

In the event of a fault, the red fault LED lights up and the symbol for the respective input flashes on the display.

No pressure build-up

The monitoring time starts when a contact time begins. If pressure switch DS does not respond within this time, relays d1 and d2 are de-energized, which switches off the pump's motor and makes the fault LED light

up. At the same time, the symbol for the DS input flashes on the display.

No pressure relief

With some units, the pressure relief is monitored by a second pressure switch (DS2). The sensor is queried at the end of an interval time. If the query shows that no pressure has been relieved, the sequence of functions is stopped and a fault signal emitted. The symbol for the DS2 input flashes on the display.

Early warning of critical lubricant level

In the case of units that signal an early warning if the level of lubricant in the reservoir drops to "Reserve", relay d3 is energized, as a result of which a connected warning light goes on. The sequence of functions is not influenced by that, i.e. the control unit remains in operating readiness and the functional sequence continues.

Low lubricant level

If the level of lubricant in the reservoir drops too far, level switch WS closes or opens, which leads to an interruption in the respective functional sequence. Relays d1 and d2 are de-energized and the fault LED lights up. At the same time, the symbol for the WS input flashes on the display.

Failure of automatic lubricant topping up

In the case of units that automatically top up lubricant, a fault signal is issued if the lubricant drops below the minimum level for an extended period of time. Relay d2 is de-energized, the fault LED lights up and the symbol for input WS_L flashes on the display. The sequence of functions is stopped.

No MK pulses

In the case of units with pulse monitoring (in the pulse counter mode only), the machine contacts MK and/or MKPV and MKUe are mutually queried. If no pulse is received at contact MKUe between two pulses arriving at contact MK/MKPV, a fault signal is emitted and the symbol for input MKUe flashes on the display.

In the opposite case, the symbol for the MK/MKPV input flashes if no pulse arrives at contact MK/MKPV between two pulses at contact MKUe.

See important product usage information on the back cover.

Relay d2 in faulty operation

If a fault occurs, relay d2 is de-energized and the sequence of functions is stopped.

Clearing an error message

An error message can only be cleared by pressing the  button which triggers intermediate lubrication, or by turning off the power.

In the case of units with a power-failure memory, the error message can only be cleared by pressing the  button.

A level switch error message can only be cleared if enough lubricant is topped up.

Note:

Do not clear an error message until its cause has been remedied.

EXZT2A02

Modes of operation

The EXZT2A02 control unit can be used as a pulse generator (mode B) or pulse counter (mode D).

Scope of functions

The EXZT2A02 comes with the following functions:

- adjustable interval time
- adjustable monitoring time
- adjustable pump delay time
- pump runtime limitation
- monitoring of pressure build-up (NO contact)
- monitoring of pressure relief (NO contact)
- monitoring of lubricant level (NO contact)
- interval time extension

The table on page 5 shows the adjustable and preset parameters.

Wiring diagram EXZT2A02

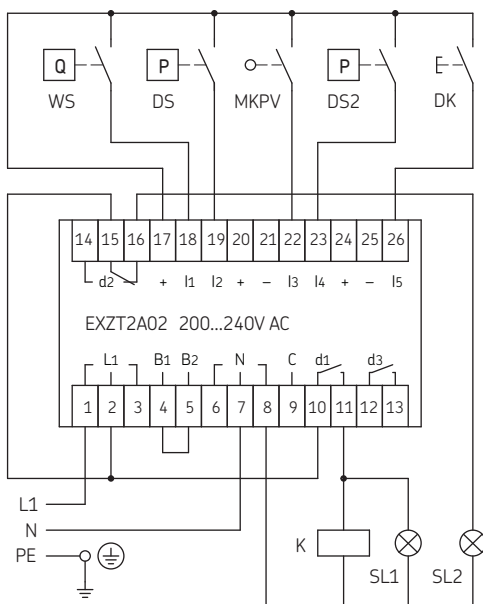

- L1/N = operating voltage
 B1/B2 = jumper terminals for voltage range (illustration: 200...240 V)
 C = potential-free terminal
 WS = lubricant level switch (illustration: reservoir full)
 DS = pressure switch (monitoring of pressure build-up)
 DS2 = pressure switch (monitoring of pressure relief), illustration: pressure relief
 DK = pushbutton
 1. intermediate lubrication
 2. clear fault
 MKPV = machine contact/interval time extension
 + = +24 V DC output
 - = 0 V DC output
 d1 = load contact for lubricant pump
 d2 = changeover contact, command link
 break contact: fault display
 make contact: operation OK
 SL1 = indicator light for "PUMP ON"
 SL2 = indicator light for "FAULT"
 K = pump motor contactor

EXZT2A05

Modes of operation

The control unit EXZT2A05 control unit can be used as a pulse generator (mode B) or pulse counter (mode D).

Scope of functions

The EXZT2A05 comes with the following functions:

- adjustable interval time
- adjustable monitoring time
- adjustable pump delay time
- pump runtime limitation
- monitoring of pressure build-up (NO contact)

- monitoring of lubricant level (NC contact)
- interval time extension
- pulse monitoring

The table shows the adjustable and preset parameters.

Adjustable and preset parameters (EXZT2A02 and EXZT2A05)

Designation	Abbreviation	Presetting	Units	Setting range	Units
Mode of operation	BA	B		B (pulse generator) D (pulse counter)	
Interval time EXZT2A02	TP	10	seconds	01 E 00 - 99 E 04 (BA: B) 01 E 00 - 99 E 04 (BA: D)	seconds pulses
Interval time EXZT2A05				02 E 00 - 99 E 04 (BA: B) 02 E 00 - 99 E 04 (BA: D)	Sekunden pulses
Monitoring time	TU	60	seconds	01 E 00 - 99 E 04	seconds
Delay time	TN	15	seconds	01 E 00 - 25 E 00	seconds

Wiring diagram EXZT2A05

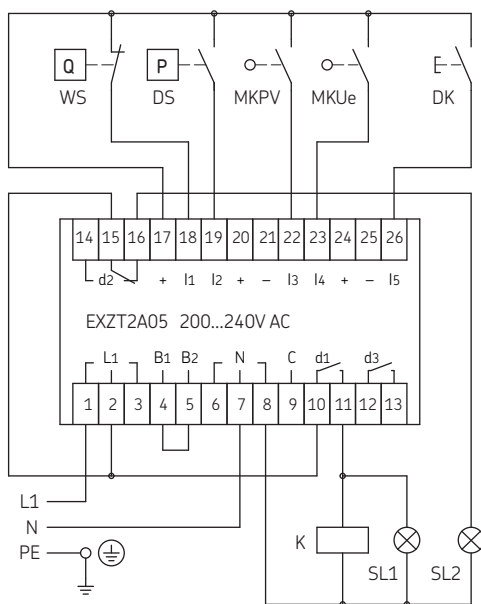

- L1/N = operating voltage
- B1/B2 = jumper terminals for voltage range (illustration: 200...240 V)
- C = potential-free terminal
- WS = lubricant level switch (illustration: reservoir full)
- DS = pressure switch (monitoring of pressure build-up)
- MKPV = machine contact/interval time extension
- MKUe = machine contact (pulse monitoring)
- DK = pushbutton
 - 1. intermediate lubrication
 - 2. clear fault
- + = +24 V DC output
- = 0 V DC output
- d1 = load contact for lubricant pump
- d2 = changeover contact, command link
 - break contact: fault display
 - make contact: operation OK
- d3 = load contact for pulse-error display
- SL1 = indicator light for "PUMP ON"
- SL2 = indicator light for "FAULT"
- SL2 = indicator light for "PULSE ERROR"
- K = pump motor contactor

EXZT2A07

Modes of operation

The EXZT2A07 control unit can be used as a pulse generator (mode B) or pulse counter (mode D).

Scope of functions

The EXZT2A07 comes with the following functions:

- adjustable interval time
- adjustable monitoring time
- adjustable pump delay time
- pump runtime limitation
- monitoring of pressure build-up (NO contact)
- monitoring of lubricant level (NC contact)
- early warning of critical lubricant level (NC contact)
- interval time extension

The table shows the adjustable and preset parameters.

Adjustable and preset parameters (EXZT2A07)					
Designation	Abbreviation	Presetting	Units	Setting range	Units
Mode of operation	BA	B		B (pulse generator) D (pulse counter)	
Interval time	TP	10	seconds	01 E 00 - 99 E 04 (mode: B) 01 E 00 - 99 E 04 (mode: D)	seconds pulses
Monitoring time	TU	60	seconds	01 E 00 - 99 E 04	seconds
Delay time	TN	15	seconds	01 E 00 - 25 E 00	seconds

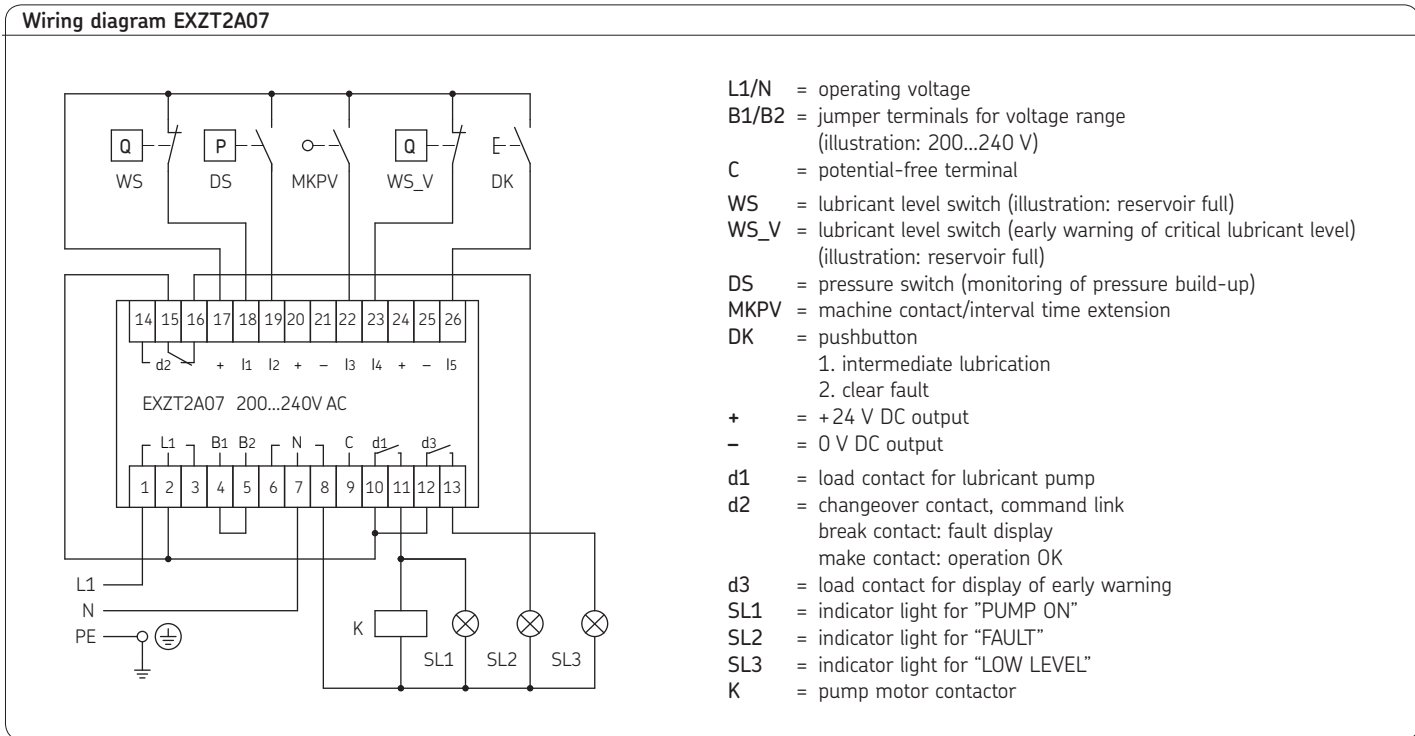

IGZ36-20, IGZ36-20-S6

Modes of operation

The IGZ36-20 and IGZ36-20-S6 units can be used as pulse generators (mode B) or as pulse counters (mode D).

Scope of functions

The IGZ36-20 and IGZ36-20-S6 units come with the following functions:

- adjustable interval time
- adjustable monitoring time
- adjustable pump delay time
- pump runtime limitation
- monitoring of pressure build-up (NO contact)
- monitoring of pressure relief (NC contact)
- monitoring of lubricant level (IGZ36-20: NO contact)
- monitoring of lubricant level (IGZ36-20-S6: NC contact)

The table shows the adjustable and preset parameters.

Adjustable and preset parameters (IGZ36-20 and IGZ36-20-S6)

Designation	Abbreviation	Presetting	Units	Setting range	Units
Mode of operation	BA	B		B (pulse generator) D (pulse counter)	
Interval time	TP	10	minutes	01 E 00 - 99 E 04 (mode: B) 01 E 00 - 99 E 04 (mode: D)	minutes pulses
Monitoring time	TU	60	seconds	10 E 00 - 10 E 01	seconds
Delay time	TN	15	seconds	01 E 00 - 30 E 00	seconds

IGZ36-20

Wiring diagram IGZ36-20

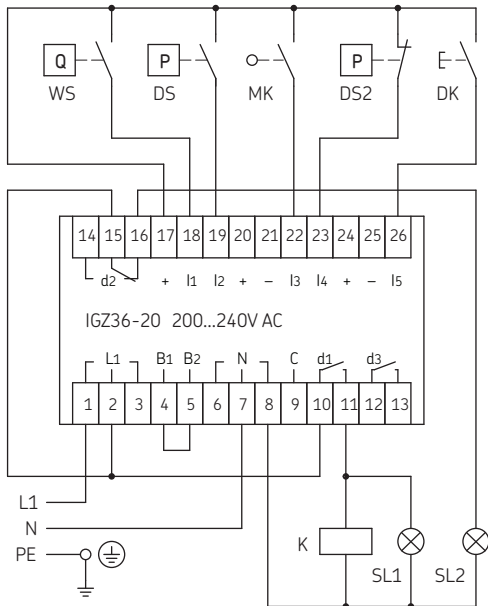

- L1/N = operating voltage
- B1/B2 = jumper terminals for voltage range (illustration: 200...240 V)
- C = potential-free terminal
- WS = lubricant level switch (illustration: reservoir full)
- DS = pressure switch (monitoring of pressure build-up)
- DS2 = pressure switch (monitoring of pressure relief) (illustration: pressure relief)
- MK = machine contact
- DK = pushbutton
 1. intermediate lubrication
 2. clear fault
- + = + 24 V DC output
- = 0 V DC output
- d1 = load contact for lubricant pump
- d2 = changeover contact, command link
break contact: fault display
make contact: operation OK
- SL1 = indicator light for "PUMP ON"
- SL2 = indicator light for "FAULT"
- K = pump motor contactor

Pulse diagram IGZ36-20 (time axis not to scale)

Normal routine

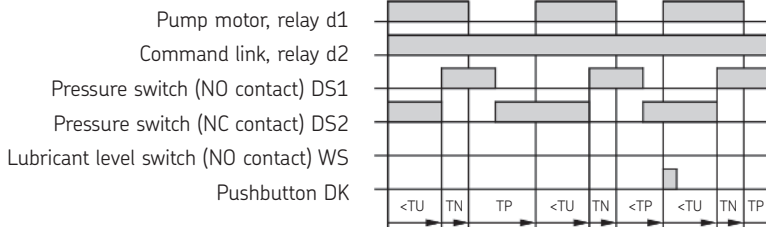

Routine with fault, no pressure build-up

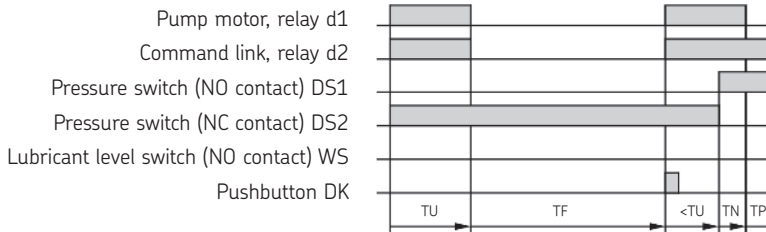

Routine with fault, lubricant level

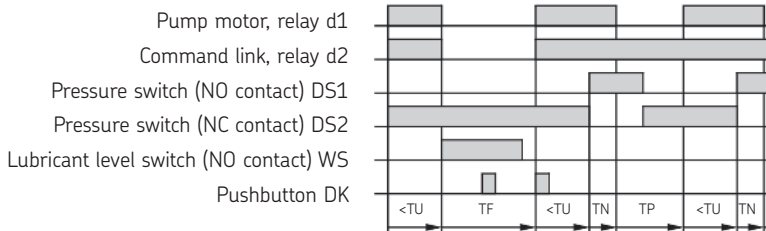

TU = monitoring time
 TN = pump delay time
 TP = interval time
 TF = functional sequence stopped

IGZ36-20-S6

Wiring diagram IGZ36-20-S6

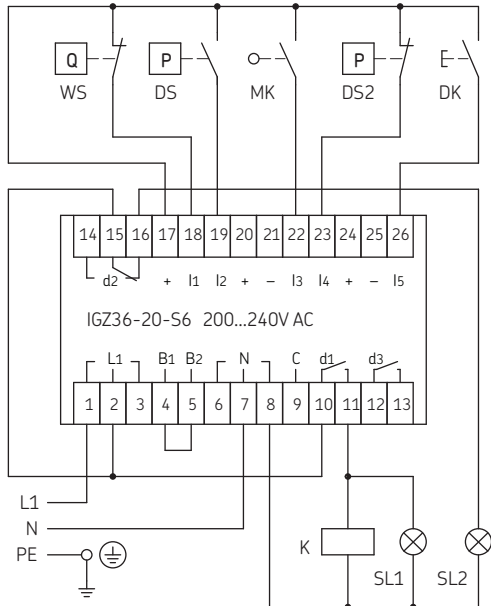

- L1/N = operating voltage
- B1/B2 = jumper terminals for voltage range (illustration: 200...240 V)
- C = potential-free terminal
- WS = lubricant level switch (illustration: reservoir full)
- DS = pressure switch (monitoring of pressure build-up)
- DS2 = pressure switch (monitoring of pressure relief)
- MK = machine contact
- DK = pushbutton
 1. intermediate lubrication
 2. clear fault
- + = +24 V DC output
- = 0 V DC output
- d1 = load contact for lubricant pump
- d2 = changeover contact, command link
 - break contact: fault display
 - make contact: operation OK
- SL1 = indicator light for "PUMP ON"
- SL2 = indicator light for "FAULT"
- K = pump motor contactor

Pulse diagram IGZ36-20-S6 (time axis not to scale)

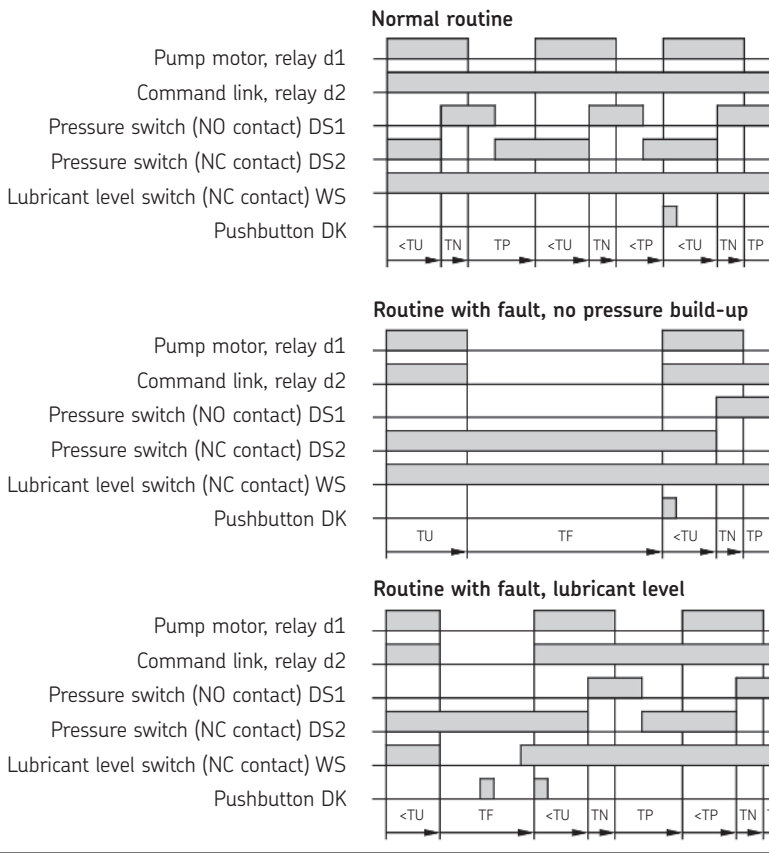

TU = monitoring time
 TN = pump delay time
 TP = interval time
 TF = functional sequence stopped

IGZ38-30, IGZ38-30-S1

Modes of operation

The IGZ38-30 and IGZ38-30-S1 can be used as a pulse generator (mode B) or as a pulse counter (mode D).

Scope of functions

The IGZ38-30 and IGZ38-30-S1 units come with the following functions:

- adjustable interval time
- pump runtime limitation
- monitoring of pressure build-up (NO contact)
- monitoring of lubricant level (IGZ38-30: NC contact)
- monitoring of lubricant level (IGZ38-30-S1: NO contact)

The table shows the adjustable and preset parameters.

Adjustable and preset parameters (IGZ38-30 and IGZ38-30-S1)

Designation	Abbreviation	Presetting	Units	Setting range	Units
Mode of operation	BA	B		B (pulse generator) D (pulse counter)	
Interval time	TP	10	minutes	01 E 00 - 99 E 04 (mode: B) 01 E 00 - 99 E 04 (mode: D)	minutes pulses
Monitoring time	TU	60	seconds	non-adjustable	
Delay time	TN	15	seconds	non-adjustable	seconds

IGZ38-30

Wiring diagram IGZ38-30

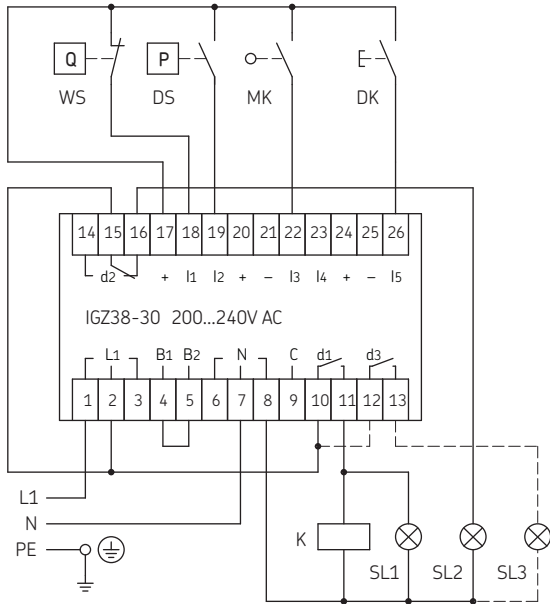

- L1/N = operating voltage
- B1/B2 = jumper terminals for voltage range (illustration: 200...240 V)
- C = potential-free terminal
- WS = lubricant level switch (illustration: reservoir full)
- DS = pressure switch (monitoring of pressure build-up)
- MK = machine contact
- DK = pushbutton
 - 1. intermediate lubrication
 - 2. clear fault
- + = +24 V DC output
- = 0 V DC output
- d1 = load contact for lubricant pump
- d2 = changeover contact, command link
 - break contact: fault display
 - make contact: operation OK
- d3 = load contact for error message display
- SL1 = indicator light for "PUMP ON"
- SL2 = indicator light for "FAULT"
- SL3 = indicator light for "FAULT" (alternative)
- K = pump motor contactor

Pulse diagram IGZ38-30 (time axis not to scale)

Normal routine

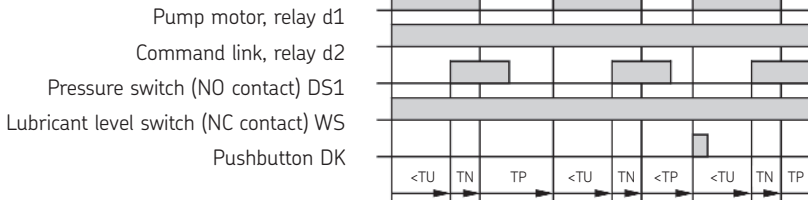

Routine with fault, no pressure build-up

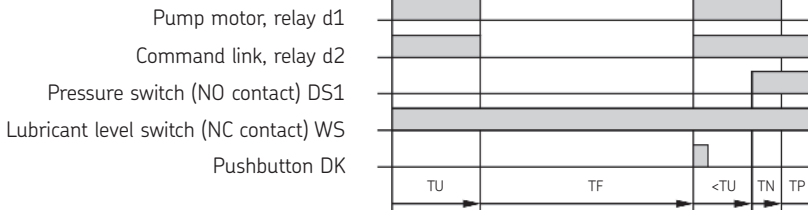

Routine with fault, lubricant level

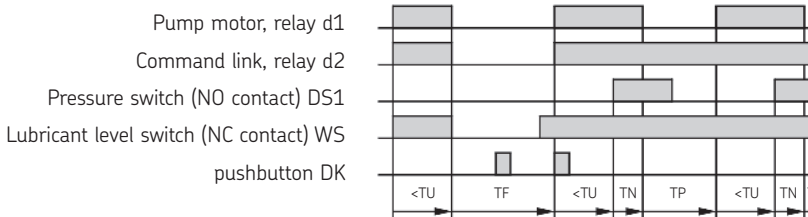

TU = monitoring time
 TN = pump delay time
 TP = interval time
 TF = functional sequence stopped

IGZ38-30-S1

Wiring diagram IGZ38-30-S1

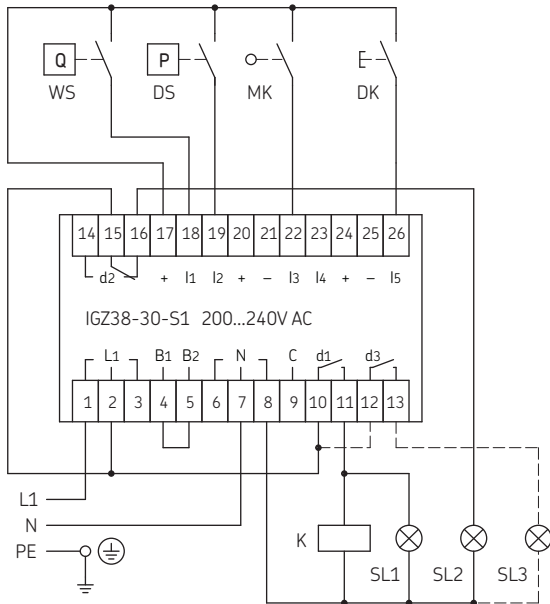

- L1/N = operating voltage
- B1/B2 = jumper terminals for voltage range (illustration: 200...240 V)
- C = potential-free terminal
- WS = lubricant level switch (illustration: reservoir full)
- DS = pressure switch (monitoring of pressure build-up)
- MK = machine contact
- DK = pushbutton
 - 1. intermediate lubrication
 - 2. clear fault
- + = + 24 V DC output
- = 0 V DC output
- d1 = load contact for lubricant pump
- d2 = changeover contact, command link
 - break contact: fault display
 - make contact: operation OK
- d3 = load contact for error message display
- SL1 = indicator light for "PUMP ON"
- SL2 = indicator light for "FAULT"
- SL3 = indicator light for "FAULT" (alternative)
- K = pump motor contactor

Pulse diagram IGZ38-30-S1 (time axis not to scale)

Normal routine

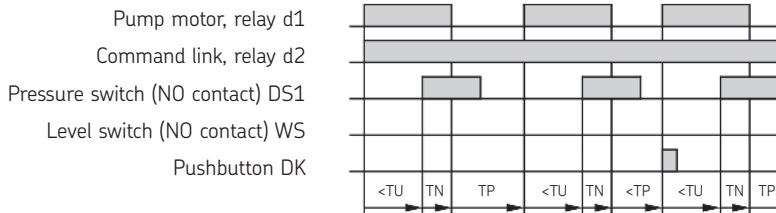

Routine with fault, no pressure build-up

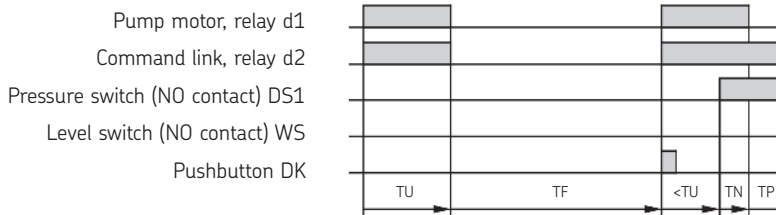

Routine with fault, lubricant level

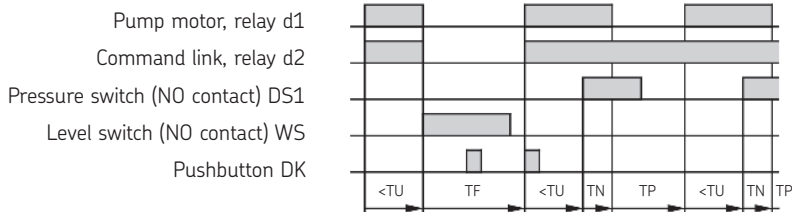

TU = monitoring time
 TN = pump delay time
 TP = interval time
 TF = functional sequence stopped

IGZ51-20-S3

Modes of operation

The IGZ51-20-S3 unit has an activatable mains-failure memory (EEPROM).

That results in the following modes of operation:

- A** pulse generator with EEPROM
- B** pulse generator without EEPROM
- C** pulse generator with EEPROM
- D** pulse generator without EEPROM

Scope of functions

The IGZ51-20-S3 comes with the following functions:

- adjustable interval time
- adjustable pump delay time
- adjustable monitoring time
- pump runtime limitation
- monitoring of pressure build-up (NO contact)
- monitoring of pressure relief (NC contact)
- monitoring of lubricant level (NO contact)
- interval time extension
- activatable mains-failure memory

The table shows the preset and adjustable parameters.

Operation with power-failure memory

In the event of a power failure, the power-failure memory stores the values for the remaining interval time or any error messages.

So the unit can continue the control process at the point at which it was interrupted as soon as the power is restored.

If the power is interrupted during the monitoring time or pump delay time, the unit continues the control process with an interval. No error message is cleared by the interruption of power.

Adjustable and preset parameters (IGZ51-20-S3)

Designation	Abbreviation	Presetting	Units	Setting range	Units
Mode of operation	BA	A		A (pulse generator with EEPROM) B (pulse generator without EEPROM) C (pulse generator with EEPROM) D (pulse generator without EEPROM)	
Interval time	TU	10	minutes	01 E 00 - 99 E 04 (mode: A, B) 01 E 00 - 99 E 04 (mode: C, D)	minutes pulses
Monitoring time	TP	60	seconds	10 E 00 - 10 E 01	seconds
Delay time	TN	15	seconds	01 E 00 - 99 E 03	seconds

IGZ51-20-S3

Wiring diagram IGZ51-20-S3

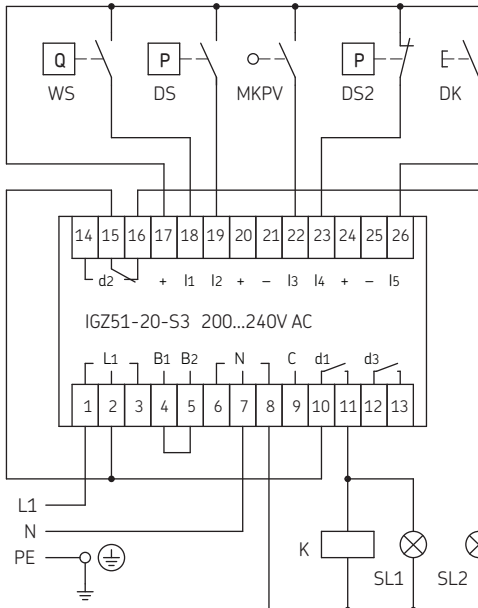

- L1/N = operating voltage
- B1/B2 = jumper terminals for voltage range (illustration: 200...240 V)
- C = potential-free terminal
- WS = lubricant level switch (illustration: reservoir full)
- DS = pressure switch (monitoring of pressure build-up)
- DS2 = pressure switch (monitoring of pressure relief)
- MKPV = machine contact/interval time extension
- DK = pushbutton
 1. intermediate lubrication
 2. clear fault
- + = +24 V DC output
- = 0 V DC output
- d1 = load contact for lubricant pump
- d2 = changeover contact, command link
 - break contact: fault display
 - make contact: operation OK
- SL1 = indicator light for "PUMP ON"
- SL2 = indicator light for "FAULT"
- K = pump motor contactor

Pulse diagram IGZ51-20-S3 (time axis not to scale)

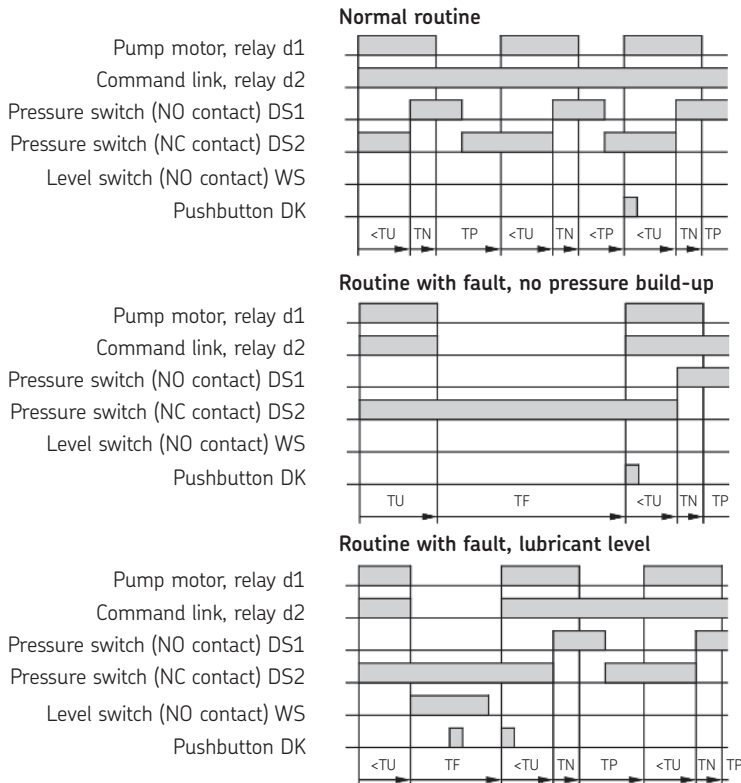

TU = monitoring time
 TN = pump delay time
 TP = interval time
 TF = functional sequence stopped

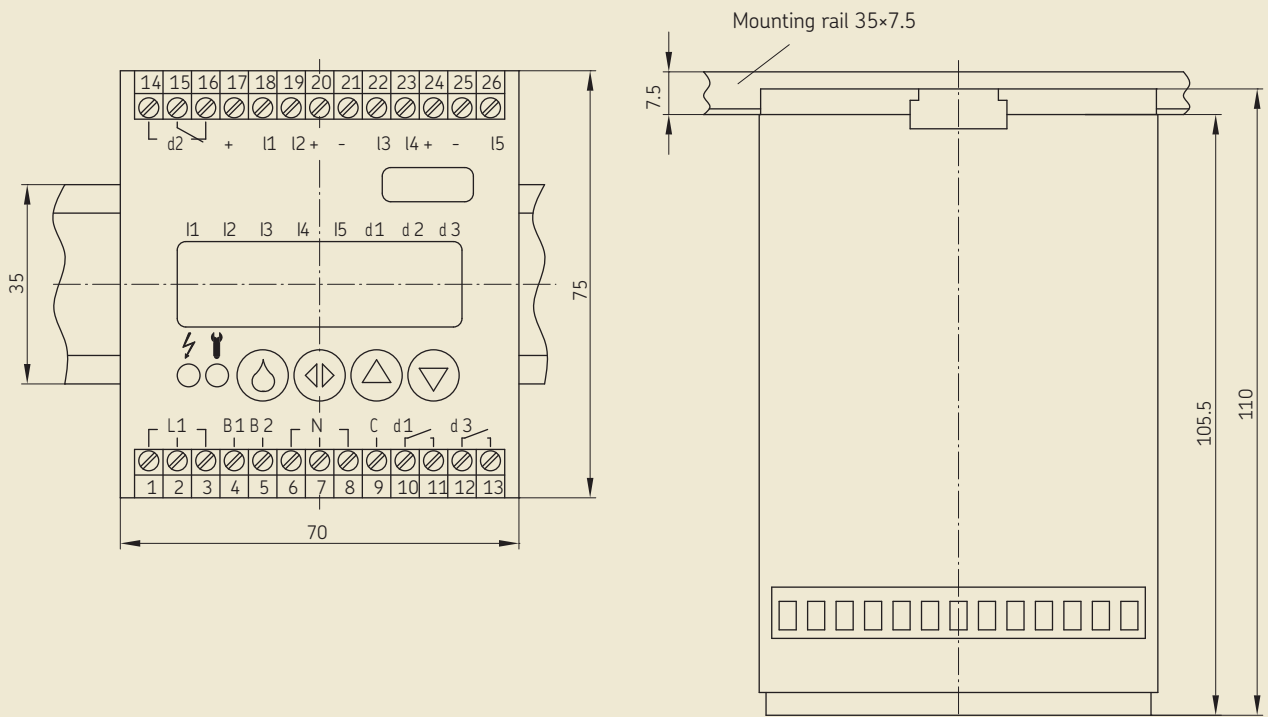

Technical Data Version +471 / +472

Rated input voltage U_n
 Version +471 100...120 V AC or 200...240 V AC
 Version +472 20...24 V DC or AC

Rated value of input voltage
 Version +471 0.85 U_n to 1.1 U_n
 (85...132 V / 170...264 V)
 Version +472 0.85 U_n to 1.1 U_n (17...26.4)

Rated frequency
 Version +471 50...60 Hz
 Version +472 DC or 50...60 Hz

Rated value of frequency
 Version +471 49...61 Hz
 Version +472 DC or 49...61 Hz

Release value of U_n max. 10%
 Recovery time 1 s

Residual ripple of input voltage
 Version +471 not applicable
 Version +472 DC: max. 5%

Max. fusing 6.3 A
 Max. switching current 5 A AC
 Max. relay switching voltage 250 V AC
 Overvoltage category to
 DIN VDE 0110 III
 Rated voltage of inputs 24 V DC
 Input impedance 2.4 k Ω \pm 10%
 Input level low 0 V...+4 V
 Input level high +10 V...+26.4 V

Coincidence factor
 for the inputs max. 0.8

Output voltage for inputs
 and external loads 24 V DC +10% / -15%

Rated output current ("+" outputs) 110 mA
 of that figure for external loads max. 60 mA

MK input, max. input frequency 30 Hz
 Pulse duty factor 1:1

Conductor connection (flexible)
 with tubular end sleeves max. 2.5 mm² or 2x 0.75 mm²
 with twin tubular end sleeves max. 2x 1.5 mm²
 stripped length 8 mm

Type of enclosure (version E) IP 30, IP 20 terminals
 Safety class (version E) II
 Rated insulation voltage 250 V AC
 Pollution degree 2
 Operating temperature 0 to +60 °C
 Storage temperature -25 to +70 °C
 Dimensions BxHxT (version E) approx. 70mmx75mmx110mm

Order No. 1-1700-4-EN

Subject to change without notice! (07/2014)

Important product usage information

All products from SKF may be used only for their intended purpose as described in this brochure and in any instructions. If operating instructions are supplied with the products, they must be read and followed.

Not all lubricants are suitable for use in centralized lubrication systems. SKF does offer an inspection service to test customer supplied lubricant to determine if it can be used in a centralized system. SKF lubrication systems or their components are not approved for use with gases, liquefied gases, pressurized gases in solution and fluids with a vapor pressure exceeding normal atmospheric pressure (1013 mbars) by more than 0.5 bar at their maximum permissible temperature.

Hazardous materials of any kind, especially the materials classified as hazardous by European Community Directive EC 67/548/EEC, Article 2, Par. 2, may only be used to fill SKF centralized lubrication systems and components and delivered and/or distributed with the same after consulting with and receiving written approval from SKF.

SKF Lubrication Systems Germany GmbH

Motzener Strasse 35/37 · 12277 Berlin · Germany
PF 970444 · 12704 Berlin · Germany
Tel. +49 (0)30 72002-0 · Fax +49 (0)30 72002-111
www.skf.com/lubrication

This brochure was presented by:

® SKF is a registered trademark of the SKF Group.

© SKF Group 2014

The contents of this publication are the copyright of the publisher and may not be reproduced (even extracts) unless prior written permission is granted. Every care has been taken to ensure the accuracy of the information contained in this publication but no liability can be accepted for any loss or damage whether direct, indirect or consequential arising out of the use of the information contained herein.

