

# Q:

What is a wheel hub bearing and why is it critical to your safety?



**A:** See inside.  
It could save  
your life.





## Q: How do my car's hub bearings affect braking safety?

**A:** Your car's hub bearings include the wheel speed sensor that controls your anti-lock braking system (ABS). This sensor sends a constant signal to the ABS control system, telling it how fast each wheel is turning. In an emergency situation, the ABS control system will determine if anti-lock braking is required.



If the ABS sensor doesn't work properly or fails, the ABS system fails, so the quality of this sensor (how it is made and protected from damage) is critical to braking safety.

## Q: Why are hub bearings critical to my traction control system?

**A:** Your car's traction control system (TCS) uses a combination of electronic drivetrain controls in conjunction with the ABS system. Since it uses the same wheel speed sensors and components as the ABS system, it can be considered a subsystem and extension of that system. Together, ABS and TCS work to provide the driver with full control over the vehicle under potentially dangerous road conditions.



## Q: Who is SKF and what makes their hub bearings better – and safer?

**A:** SKF manufactures Original Equipment hub bearings for many automakers all over the world. Our premium quality hub bearings are manufactured using high quality steel and surface finishes, premium seals, OE sensors, precision manufacturing techniques and precise assembly tolerances. Every SKF premium hub is 100% tested to the actual OE specifications per part number for fit, form and function. That means it will fit correctly and work correctly, and last as long as the original hub that came with the car when it was new. In many cases, it's the same one!

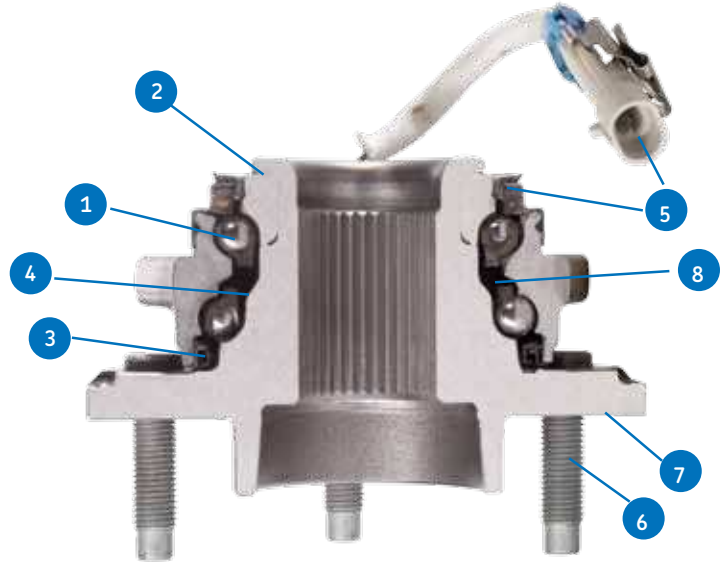

### ***BR930548K, 1997-2012 GM. Better than the original!***

**1. SKF X-Tracker® technology engineered into SKF premium hub wheel bearings**

**Benefits:** Meets demands for increased ride comfort; improves vehicle steering accuracy, handling dynamics and brake system performance

**2. Roll forming**

**Benefits:** Provides precision bearing preload and overall strength of the hub assembly for secure clamping to the CV joint and knuckle for increased safety

**3. Seal**

**Benefits:** Multiple-lip design provides optimum dirt and contaminant exclusion and keeps grease in the hub for increased operational life

**4. Bearing Cage**

**Benefits:** Patented design provides superior load capacity and lower stress on the raceway, providing a smooth roll operation for a comfortable ride

**5. Anti-lock braking system (ABS) sensor**

**Benefits:** Original Equipment design, assures correct brake response and performance

**6. Wheel Studs**

**Benefits:** Original Equipment quality, high tensile strength, prevents wheel-off conditions

**7. Low lateral run-out**

**Benefits:** Improves mating of the wheel hub to the brake rotor, which prevents brake pedal pulsation and premature brake component failure

**8. SKF GHG Grease**

**Benefits:** Exclusive and patented formula provides optimum bearing performance and life by minimizing friction

*Want a replacement hub that's as good as or better than the original? Ask for SKF premium hubs by name.*

## Q: What is a wheel hub bearing and why is it so important?

**A:** Though you may never even see it, a wheel hub bearing unit is an important part of your car's wheel assembly, enabling your wheels to turn freely and playing a crucial role in the safety and handling characteristics of your vehicle. Comprised of precision-manufactured bearings, seals and sensors in one pre-assembled unit, a wheel hub bearing unit is critical to your car's performance, from the smoothness of the ride, to fuel efficiency, to the integrity of your anti-lock braking system (ABS). So when it's time to replace one, you'll want a replacement hub bearing that's as good – and safe – as the original that came with your car when it was new.



## Q: Why are “value grade” hubs a risky choice?

**A:** Many manufacturers sell replacement hub bearings that are very low priced. Initially, you may think that is a great deal or value. Unfortunately, with that low price, you get a low quality hub bearing that is inferior to a premium, Original Equipment quality hub bearing. We call these hubs “value grade,” and experience has proven that these low performing “value grade” hubs are no real value in the long run. In fact, in many cases:

- Value grade hubs last less than half as long as premium hubs.
- Their cheaply made seals can allow moisture and contaminants to enter and destroy the bearing prematurely – requiring you to pay for a new hub in as little as 10,000 miles.
- They can produce annoying wheel vibration and noise.
- They can cause your anti-lock braking system to malfunction, leading to safety concerns for your vehicle.
- They can even result in your wheel coming off while you are driving – potentially causing a fatal accident.

## Q: Could my wheel really come off?

**A:** YES! Value grade hub bearings are often made using low quality steel and/or improper manufacturing techniques. These hubs can degrade quickly and cause excessive vibration and noise. In some cases, the steel can fracture and cause a wheel to break off at high speeds.

Q: How do hub bearings affect braking safety? See inside.



Alfa Romeo  
Audi  
BMW  
Chrysler  
Citroen  
Ferrari  
Fiat  
Ford  
General Motors  
Honda  
Hyundai  
Jaguar  
Kia  
Mazda  
Mercedes-Benz  
Nissan  
Opel  
Peugeot  
Porsche  
Renault  
Saab  
Toyota  
Volkswagen  
Volvo

## Unquestionable quality for OEMs – and for you

SKF is a trusted engineering partner and parts supplier to every major vehicle manufacturer, and we continue to win industry awards and accolades from our customers. Through our distributor partners, we make this same level of quality available in the aftermarket, under the SKF brand. Invest in quality, safety and reliability. Ask for SKF premium hub bearings by name.

© SKF is a registered trademark  
of the SKF Group.

© SKF Group 2012

SKF VSM NA  
890 N. State Street  
Suite 200  
Elgin, IL 60123  
1-800-882-0008  
[www.vsm.skf.com](http://www.vsm.skf.com)

The contents of this publication are the copyright of the publisher and may not be reproduced (even extracts) unless permission is granted. Every care has been taken to ensure the accuracy of the information contained in this publication but no liability can be accepted for any loss or damage whether direct, indirect or consequential arising out of the use of the information contained herein.

Publication 457280 (5/12)

Printed in U.S.A.

