

SKF Nautilus advanced bearing arrangements

Simplified mounting and dismounting,
increased reliability and enhanced safety



Big turbine challenges?

Meet them with advanced SKF Nautilus bearing solutions

The wind energy market increasingly demands turbines designed to reduce total costs while providing high reliability, operational safety and ease of serviceability. Main shaft bearings in drive trains play a critical role in achieving these goals.

The proven Nautilus solution

The original SKF Nautilus double row tapered roller bearing is well known for successfully extending drive train service life and increasing turbine reliability. All rotor loads are carried by a single bearing, rather than on a traditional two-bearing arrangement that handles radial and axial loads separately. By doing the work of two bearings, the Nautilus bearing enables the bearing to be integrated directly into the machine frame and the hub. As a result, only the rotor torque is transmitted to the drive train.

Less weight, longer life

Designed to handle heavy and complex loads, SKF Nautilus is a single bearing solution based on double row tapered roller bearings, arranged back-to-back. These two rows lock the unit axially and deliver extremely high stiffness. The compact bearing design helps reduce nacelle dimensions and weight. This helps reduce production costs, in part, because tower and fundament weight can be decreased.

Manufactured with “clean” steel at state-of-the-art SKF production facilities, the Nautilus bearing combines advanced materials and optimized design to help increase turbine reliability, maintenance intervals and service life in even the harshest operating environments.

New Nautilus options – improved through experience

Now, SKF has created the next generation of Nautilus bearing solutions. Expanded and improved using knowledge gained from many SKF Nautilus-equipped designs developed in cooperation with turbine manufacturers and design consultants, these new solutions offer updated, versatile and integrated features to meet the industry's demands.

The expanded range of Nautilus solutions provides designers with the freedom to develop a wide variety of turbines – with gearboxes or directly driven; with outer or inner ring rotation; or mounted on shafts or directly bolted onto the surrounding structure. You now have more choices than ever before.

Benefits

SKF Nautilus solutions are designed to help manufacturers and end-users:

- Reduce the cost of energy
- Increase reliability and operational safety
- Simplify mounting, dismounting and replacement
- Extend maintenance intervals
- Improve serviceability
- Decrease nacelle weight

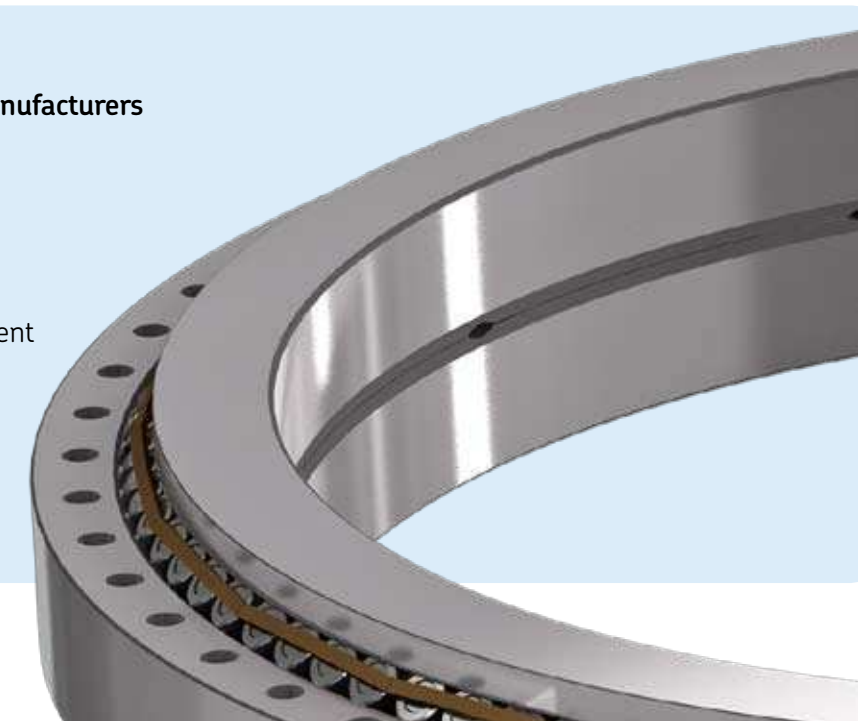

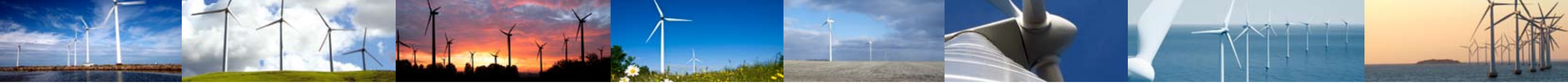

Features and benefits of the expanded range of Nautilus solutions

Single-pocket segmented cage

- Increased reliability and safety
- Increased load carrying capacity for extraordinary load requirements
- Minimized contact forces and friction inside the bearing

High-friction coating

- High coefficient of friction minimizes relative movement of mating components
- Improved reliability and safety

Integrated carriers and seals

- Reduced risk of contamination
- Increased maintenance intervals
- Cost and weight reduction
- Simplified seal mounting and replacement
- Versatile seal options

Pre-greased

- Optimized grease fill for increased reliability
- Virtually eliminates contamination
- Saves time and cost

Bolted inner ring

- Increased reliability and safety
- Simplified mounting, dismounting and maintenance
- Reduced risk of handling imperfections
- Cost reduction
- Delivered with correct preload to meet operational requirements

Corrosion protection

- Increased service life
- Saves time and effort

Integrated seal and pre-greased solution

SKF now offers Nautilus bearings with integrated sealing carriers to improve cleanliness and reduce the risk of bearing contamination during the turbine mounting process. In addition, this integrated seal design helps reduce weight and associated costs, and also makes it possible to easily replace seals on top of the turbine, without dismounting the carrier.

SKF engineering competence enables selection of the right seal to achieve high sealing performance, durability and extended maintenance intervals. Versatile contact seals composed of rubber and polyurethane are available. Nautilus bearings can also be delivered pre-greased, with SKF performing the initial grease fill using the proper grease amount. A variety of greases can be used, the optimal choice being dependent on the operating conditions.

Bolted inner ring

While the original Nautilus bearing comes standard with a bolted outer ring only, SKF offers the option to also incorporate a bolted inner ring. Thus, the bearing is simply bolted to the rotor hub and to the mainframe. All influences of tolerances between the bearing and the surrounding structure, such as shaft, housing and lock ring, are eliminated. This also reduces the preload variation in operating conditions leading to significantly higher operational reliability and safety.

SKF precisely calculates, manufactures and delivers the bearing with the correct preload to meet the operational requirements. To withstand loads applied in operating conditions, the amount and size of screws needed in bolted connection has to be carefully determined.

With the bolted inner ring, there is also no longer the need for the time-consuming mounting of all single components on-site or heating of bearings. This reduces the risk of handling imperfections. Simplified installation also means easy bearing replacement when necessary and reduced maintenance costs.

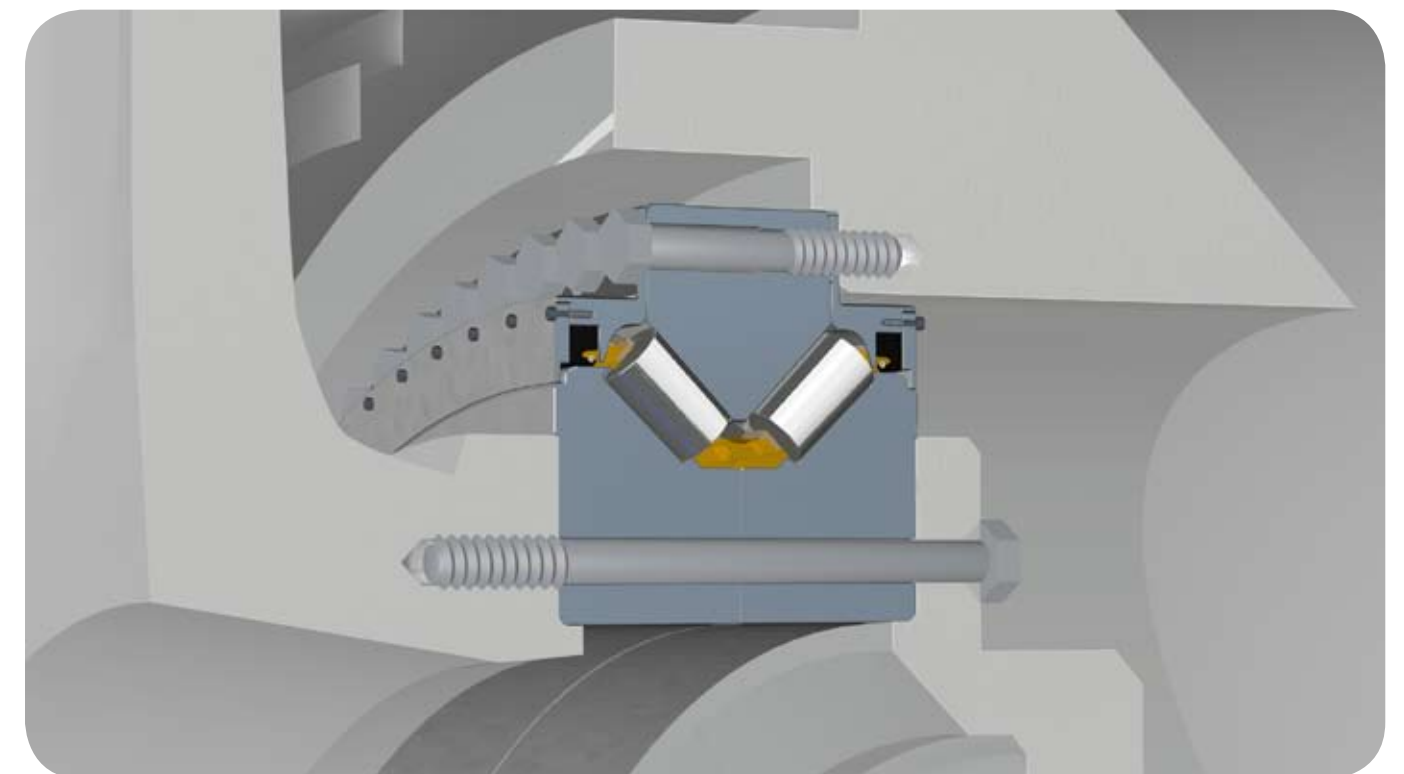



Reduced friction and advanced surface treatments



Enhanced segmented cage for higher degree of flexibility

Improving on SKF's segmented cage technology, SKF now offers the option of a single-pocket cage which accommodates a high degree of flexibility in operating conditions. Specifically, it can operate in a flexible environment with the bearing being preloaded, a prerequisite for a stiff surrounding structure resulting in a stiff drive train.

Using this segmented cage results in no additional cage forces being added to normal internal bearing forces. This new design also makes it possible to increase the static and dynamic load-carrying capacity of the bearing by keeping the same dimensions.

Along with the optimized cage geometry, the segmentation also improves the roller guiding, providing optimized load distribution among the rollers. Additionally, the

window-type cage provides extremely low friction and makes the bearing less sensitive to inadequate lubrication conditions, resulting in less wear. Therefore it is possible to use either grease or oil to lubricate the Nautilus bearing.

Corrosion protection extends service life in harsh environments

Conditions are challenging in cold climates, but especially offshore, as condensed water will always find its way into the heart of the turbine. These severe weather conditions demand high reliability components coupled with protection from the environment. Proper corrosion protection for the main shaft bearing is essential.

SKF now offers Nautilus bearings protected by a special coating applied directly to critical surfaces. Experienced SKF engineers help to ensure proper protection by specifying the correct consistency of this coating as well as which areas of the bearing need to be coated.

Importantly, this corrosion-inhibiting material can be applied without sandblasting, eliminating dust and creating a cleaner manufacturing environment and safer

conditions for workers. And unlike epoxy, this coating is ready for use and reuse any-time, avoiding waste during the production process.

High-friction coating for high reliability and safety

Rotor loads and twisting moments, caused by wind conditions, are carried by the drivetrain. With a Nautilus bearing arrangement and certain turbine designs, the torque experienced by the drivetrain has to be transferred through bolted connections through the inner rings or the outer ring respectively. The size and amount of those bolts are carefully calculated to cope with those torques by considering common coefficient of friction in steel to steel contact.

However, in extreme cases the coefficient of friction may not be high enough. To counteract this phenomenon, SKF has developed a high-friction coating (patent pending), which is applied to bearing surfaces that contribute to torque transfer. This virtually eliminates micro-movements, helping to increase operational safety and reliability.



Real world experience, real world solutions

With decades of industry experience and expertise in many areas affecting turbine performance, SKF can provide a wide range of products and services to help you achieve your reliability goals. These include:



SKF Engineering Consultancy Services

Incorporating more than 100 years of rotating machinery expertise, SKF Engineering Consultancy Services can help to design a Nautilus-equipped turbine that will be "right" from the start. Drawing on application experience ranging from the earliest wind turbines to the latest designs, SKF engineers can help you avoid design and development setbacks and identify more profitable approaches.

By applying advanced engineering analysis and calculations, we can help you define your optimum bearing solution during all load cases. Using an SKF "virtual" test rig, we can also simulate different operating conditions of multimewatt wind turbines.

SKF engineers will also help you consider the effects of surrounding components, as well as defining approaches to maximize service life and reliability. In this way, we can help you achieve a "best fit for application."

SKF condition monitoring system

SKF WindCon is an easy-to-manage, online condition monitoring system that helps reduce operating costs. Easily installed on all turbine sizes and types, on land or at sea, the system continuously monitors single units or entire farms to reliably predict the need for maintenance tasks.



SKF greases

SKF offers a range of bearing greases that provide proper lubrication, both when the turbine is operating or in standstill mode. SKF greases have excellent water and corrosion resistance, superior performance at low starting torque, and high thermal and mechanical stability. SKF application specialists can help you select the grease best suited to your application requirements.

SKF automatic lubrication systems

Proper lubrication with an automatic lubrication system can reduce maintenance needs and, by helping to avoid over-greasing, also minimize environmental impact. SKF lubrication solutions include centralized automatic lubrication systems specifically designed for wind turbine applications. These systems deliver the right amount of the appropriate lubricant at the right positions, at the right time, for all rotating equipment.

SKF seals

Advanced SKF sealing solutions provide excellent lubricant retention and contaminant exclusion, protecting both the bearing and the environment by eliminating leakage.



The Nautilus bearing sealing solutions have outstanding ozone and abrasion resistance characteristics, resulting in highly reliable sealing performance and extended service life. The seals are designed to be easily replaced on-site, resulting in reduced maintenance time and costs.

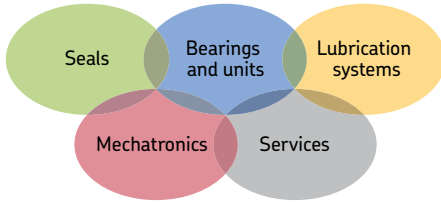

The Power of Knowledge Engineering

Drawing on five areas of competence and application-specific expertise amassed over more than 100 years, SKF brings innovative solutions to OEMs and production facilities in every major industry worldwide. These five competence areas include bearings and units, seals, lubrication systems, mechatronics (combining mechanics and electronics into intelligent systems), and a wide range of services, from 3-D computer modelling to advanced condition monitoring and reliability and asset management systems. A global presence provides SKF customers uniform quality standards and worldwide product availability.

© SKF and SKF Nautilus are registered trademarks of the SKF Group.

© SKF Group 2012

The contents of this publication are the copyright of the publisher and may not be reproduced (even extracts) unless prior written permission is granted. Every care has been taken to ensure the accuracy of the information contained in this publication but no liability can be accepted for any loss or damage whether direct, indirect or consequential arising out of the use of the information contained herein.

PUB 74/P412744 EN • March 2012

This publication supersedes publication 74/S7 10159 EN

Printed in Sweden on environmentally friendly paper.

Certain image(s) used under license from Shutterstock.com

