

Super-precision angular contact ball bearings: High-speed, B design, sealed as standard



S719 .. B (HB .. /S) and S70 .. B (HX .. /S) series





The SKF brand now stands for more than ever before, and means more to you as a valued customer.

While SKF maintains its leadership as a high-quality bearing manufacturer throughout the world, new dimensions in technical advances, product support and services have evolved SKF into a truly solutions-oriented supplier, creating greater value for customers.

These solutions enable customers to improve productivity, not only with breakthrough application-specific products, but also through leading-edge design simulation tools and consultancy services, plant asset efficiency maintenance programmes, and the industry's most advanced supply management techniques.

The SKF brand still stands for the very best in rolling bearings, but it now stands for much more.

SKF – the knowledge engineering company

Contents

A Product information

SKF sealed super-precision angular contact ball bearings in the S719 .. B (HB .. /S) and S70 .. B (HX .. /S) series 3

The assortment 4
High-speed, B design bearings..... 5
Bearing series 5
Bearing variants..... 6
Single bearings and matched bearing sets 7

Applications 8

B Recommendations

Bearing selection 10

Bearing arrangement design 11
Single bearings..... 11
Bearing sets..... 11
Type of arrangement 12
Application examples 14

Lubrication and maintenance 16
Sealed bearings 16
Grease lubrication for open bearings 16
Running-in of sealed and open, grease lubricated bearings 17
Oil lubrication for open bearings..... 18

C Product data

Bearing data – general 20
Boundary dimensions 20
Chamfer dimensions 20
Tolerances 20
Bearing preload 21
Bearing axial stiffness 25
Fitting and clamping of bearing rings .. 26
Load carrying capacity of bearing sets . 27
Equivalent bearing loads 27
Attainable speeds..... 28
Cages..... 29
Seals 29
Materials 29
Heat treatment 29
Marking of bearings and bearing sets.. 30
Packaging 31
Designation system 31

Product tables..... 34

D Additional information

Setting the highest standard for precision bearings 42
Super-precision angular contact ball bearings..... 42
Super-precision cylindrical roller bearings..... 43
Super-precision double direction angular contact thrust ball bearings 43
Super-precision angular contact thrust ball bearings for screw drives 43
Super-precision axial-radial cylindrical roller bearings 43

SKF – the knowledge engineering company 46

SKF sealed super-precision angular contact ball bearings in the S719 .. B (*HB .. /S*) and S70 .. B (*HX .. /S*) series

When contaminants, such as wood dust or swarf, get between the balls and raceways of a precision bearing, damage in the contact areas is almost inevitable. When cutting fluid enters the bearing, it reduces the effectiveness of the lubricant, making the bearing susceptible to corrosion, higher operating temperatures and accelerated wear.

The end result of both of these scenarios is high maintenance costs combined with lost revenues from unplanned downtime and lost production.

SKF sealed super-precision bearings can virtually eliminate the problem of premature bearing failures resulting from contamination. Where open bearings with external seals have been previously used, sealed super-precision bearings provide superior performance.

Ready-to-mount sealed super-precision angular contact ball bearings in the S719 .. B (*HB .. /S*)¹⁾ and S70 .. B (*HX .. /S*) series are characterized by:

- high-speed capability
- high stiffness
- extended bearing service life
- low heat generation
- compact cross section

Machine tool design is becoming increasingly complex, particularly for multiple axis machining centres. Exceptional demands are placed on the main sub-assemblies such as the drives. SKF sealed super-precision angular contact ball bearings provide optimum performance in applications where there is a need for high reliability and superior accuracy. The bearings are filled with high-speed grease. Non-contact seals keep the grease in and contaminants out of the bearings, with the lowest possible temperature rise and without compromising speed capability.

These relubrication-free bearings are particularly suitable for metal cutting and woodworking machines.



¹⁾ Where applicable, designations in parentheses and italics refer to the corresponding SNFA equivalent.

The assortment

Sealed angular contact ball bearings in the S719 .. B (*HB .. /S*) and S70 .. B (*HX .. /S*) series have now been added to the SKF assortment of super-precision bearings. To accommodate the diverse operating requirements of precision applications, bearings in these series are available with three contact angles and two ball materials.

The bearings are manufactured to two tolerance classes and accommodate shaft diameters ranging from 30 to 120 mm. Those suitable for universal matching or mounting in sets are produced to three preload classes. The bearings are fitted, standard, with a seal on both sides. Bearings without seals are also available.

Bearings in the S719 .. B (*HB .. /S*) and S70 .. B (*HX .. /S*) series, like all angular contact ball bearings, are nearly always adjusted against a second bearing to balance the counterforces. To accommodate increased loads and axial loads in both directions, the bearings are used in sets consisting, typically, of up to four bearings. Matched bearing sets with a special preload can be supplied on request.



SKF sealed super-precision angular contact ball bearings: High-speed, B design

Features

- Ready-to-mount
- Non-contact seals
- High-speed grease
- Maximum number of very small balls
- P4A or PA9A tolerance classes
- Optimized chamfer design
- ISO 19 and 10 dimensions series
- Asymmetrical inner and outer rings
- Lightweight phenolic resin cage

Benefits

- Shorter mounting time
- Prevent entry of contaminants, relubrication-free, extended bearing service life
- High-speed capability, good thermal stability
- Provide a high degree of rigidity
- Superior running accuracy, short running-in time
- Facilitated mounting
- Compact cross sections
- Accommodate radial loads, and axial loads in one direction
- Low friction, high-speed capability

High-speed, B design bearings

Super-precision single row angular contact ball bearings in the S719 .. B (HB .. /S) and S70 .. B (HX .. /S) series are designed for high-speed operation and are best suited for light load and low temperature operating conditions.

Features of B design bearings include:

- asymmetrical inner and outer rings
- a high number of very small balls
- a lightweight phenolic resin cage
- an optimized chamfer design

The asymmetrical bearing rings enable the bearings to accommodate radial loads, and axial loads in one direction. The outer ring shoulder-guided cage is designed to enable good lubricant supply to the ball/raceway contact areas. The shape of the chamfer of the inner and outer rings is optimized for improved mounting accuracy. As a result, mounting is not only facilitated, but there is also less risk of damage to associated components. When compared to other angular contact ball bearings in the 719 and 70 series, B design bearings have the greatest possible number of very small balls for increased rigidity.

A non-contact seal is fitted, standard, on both sides of the bearing outer ring. The seal forms an extremely narrow gap with the cylindrical surface of the inner ring shoulder.

Non-contact seal for high-speed operation

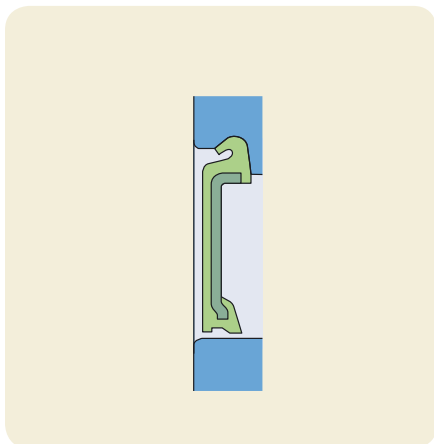

Bearing series

The assortment of super-precision bearings presented in this brochure includes two ISO dimensions series:

- the extremely light 719 (HB) series
- the light 70 (HX) series

Bearings in both these series are suitable for high-speed operation and tight radial mounting space. If increased rigidity is required, bearings in the 719 (HB) series are used instead of bearings in the 70 (HX) series, as they contain the greater number of balls, relative to their bore size. Bearings in the 719 (HB) series also accommodate a larger shaft diameter, relative to their outside diameter, when compared to bearings in the 70 (HX) series.

B design bearings for high-speed operation and increased rigidity

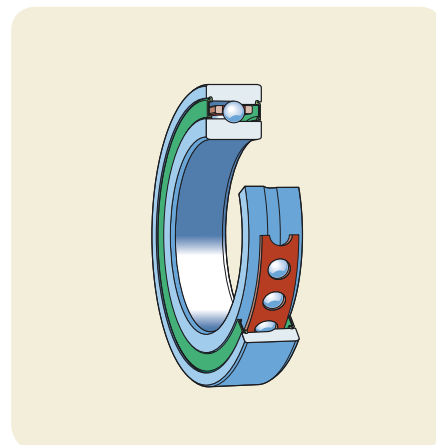

When increased system rigidity is required, bearings in the 719 (HB) series accommodate a larger shaft diameter for a given outside diameter, compared to bearings in the 70 (HX) series.

Optimized design of bearing ring chamfer to facilitate mounting

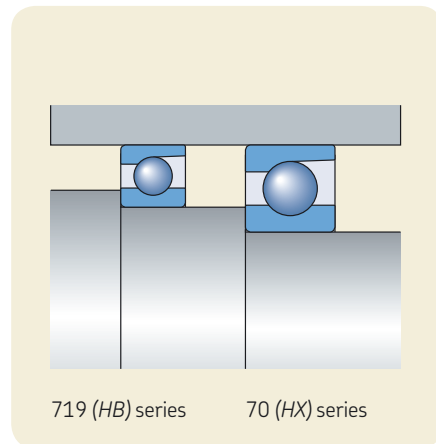
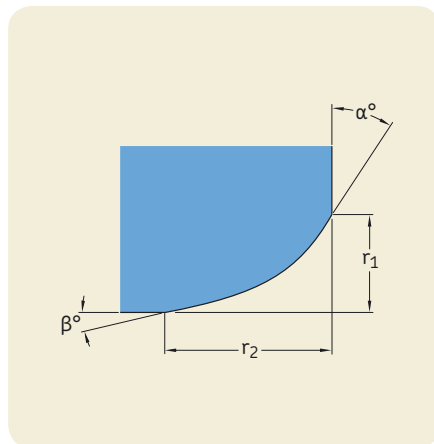

Bearing variants

Based on the operating conditions in precision applications, bearing requirements can vary. As a result, there are many variants of SKF super-precision angular contact ball bearings in the 719 .. B (HB) and 70 .. B (HX) series to choose from.

Standard bearings are manufactured with an integral seal fitted on both sides and filled with premium grease. As there is no friction generated at the seal lip, the attainable speed of a sealed bearing is equivalent to a comparably sized open bearing.

When compared to bearing arrangements with open bearings and external seals, those with sealed bearings provide a number of advantages including:

- extended bearing service life
- reduced need for maintenance
- reduced inventory
- reduced risk of lubricant contamination during mounting and operation

Sealed bearings are identified by the designation prefix S (suffix /S).

Contact angles

Standard bearings are manufactured with the following contact angles:

- a 15° contact angle, designation suffix CB (1)
- a 25° contact angle, designation suffix ACB (3)

Bearings with an 18° contact angle, designation suffix FB (2), are available on request.

With three contact angles to choose from, designers can optimize their application based on axial load, speed and rigidity requirements.

Standard bearings are manufactured with an integral seal fitted on both sides.

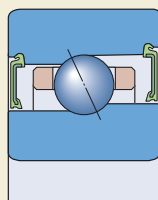

Sealed variant

Three contact angles accommodate axial load, speed and rigidity requirements.

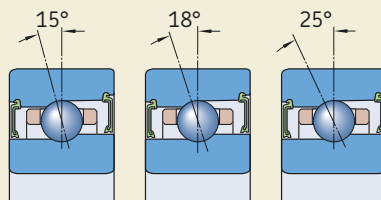

The bearings are available in an all-steel and hybrid variant.

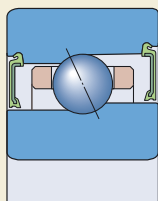

Steel balls

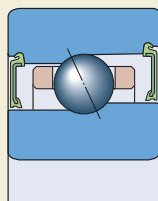

Ceramic balls

The bearings are available, standard, with seals but are also available in two open variants.

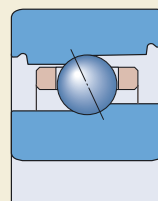

Open variant

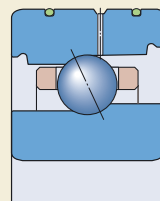

Open variant for direct oil lubrication

Ball materials

Standard bearings are available with:

- steel balls, no designation suffix
- ceramic (bearing grade silicon nitride) balls, designation suffix HC (/NS)

As ceramic balls are considerably lighter and harder than steel balls, hybrid bearings can provide a higher degree of rigidity and run considerably faster than comparably sized all-steel bearings. The lower weight of the ceramic balls reduces the centrifugal forces within the bearing and generates less heat. Lower centrifugal forces are particularly important in machine tool applications where there are frequent rapid starts and stops. Less heat generated by the bearing means less energy consumption and longer bearing and grease service life.

Open bearings

The bearings are also available without seals for grease or oil lubrication in the 719 .. B (HB) and 70 .. B (HX) series. To facilitate direct oil lubrication, the outer ring of open bearings can also be manufactured with an annular groove and two lubrication holes as well as two annular grooves to accommodate O-rings. This bearing variant is identified by the designation suffix L (GH).

Single bearings and matched bearing sets

SKF bearings in the S719 .. B (HB .. /S) and S70 .. B (HX .. /S) series are available, standard, as:

- single bearings
- single, universally matchable bearings
- matched bearing sets
- sets of universally matchable bearings



Applications

In the highly contaminated environment of a machine tool spindle, one of the primary causes of premature bearing failure is the ingress of solid contaminants and/or cutting fluid into the bearing cavity. To eliminate this problem, the SKF assortment of sealed super-precision angular contact ball bearings in the S719 .. B (HB .. /S) and S70 .. B (HX .. /S) series is an excellent solution. The ability of the bearings to provide a high degree of rigidity and accommodate high speeds with extremely low runout provides a variety of benefits for different applications.

Applications

- Electro-spindles
- Metal cutting machines
- Woodworking machines
- Milling machines
- Machining centres

Requirements

- Efficient sealing against contaminants
- Low energy consumption
- Long service life
- Facilitated mounting
- Increased machine uptime
- High power density for compact designs
- High positioning accuracy

Solution



SKF sealed super-precision angular contact ball bearings in the S719 .. B (HB .. /S) and S70 .. B (HX .. /S) series



Bearing selection

Bearing selection is paramount when dealing with applications that require a high degree of accuracy at high speeds. The many variants of SKF sealed super-precision angular contact ball bearings are well suited to accommodate the conditions dictated by these applications.

The main criteria when selecting bearings in the S719 .. B (HB .. /S) and S70 .. B (HX .. /S) series are:

- precision
- rigidity
- speed
- load

Precision

When dealing with rolling bearings, precision is described by tolerance classes for running and dimensional accuracy.

When selecting bearings in the S719 .. B (HB .. /S) and S70 .. B (HX .. /S) series, the following should be considered:

- All bearing variants are manufactured, standard, to P4A (better than ABEC 7) tolerance class.
- All bearing variants can be manufactured to the higher precision PA9A (better than ABEC 9) tolerance class, on request.

Rigidity

In precision applications, the rigidity of the bearing arrangement is extremely important, as the magnitude of elastic deformation under load determines the productivity and accuracy of the equipment. Although bearing stiffness contributes to system rigidity, there are other influencing factors such as the number and position of the bearings.

When selecting bearings in the S719 .. B (HB .. /S) and S70 .. B (HX .. /S) series, the following should be considered:

- Ceramic (silicon nitride) balls provide a higher degree of stiffness than steel balls.

- A larger contact angle provides a higher degree of axial stiffness.
- When increased system rigidity is required, bearings in the 719 (HB) series accommodate a larger shaft diameter for a given outside diameter, compared to bearings in the 70 (HX) series.
- Bearings mounted in a back-to-back arrangement provide the highest degree of rigidity.

Speed

High-speed applications require cool-running, low-friction bearings like super-precision angular contact ball bearings.

When selecting bearings in the S719 .. B (HB .. /S) and S70 .. B (HX .. /S) series, the following should be considered:

- Hybrid bearings can operate at higher speeds than comparably sized all-steel bearings.
- As the contact angle increases, speed capability decreases.

Load

In high-speed precision applications, the load carrying capacity of a bearing is typically less important than in general engineering applications. Angular contact ball bearings can accommodate radial and axial loads acting simultaneously. When these combined loads exist, the direction of the load also plays an important role in the selection process.

When selecting bearings in the S719 .. B (HB .. /S) and S70 .. B (HX .. /S) series, the following should be considered:

- The greater the contact angle, the higher the axial load carrying capacity of the bearing.
- The axial load carrying capacity of a bearing arrangement can be increased by adding bearings mounted in tandem.



Bearing arrangement design

Bearing arrangements using SKF bearings in the S719 .. B (HB .. /S) and S70 .. B (HX .. /S) series can be designed using single bearings or bearing sets. An example of the ordering possibilities for a three-bearing arrangement is provided in **table 1**.

Single bearings

SKF bearings in the S719 .. B (HB .. /S) and S70 .. B (HX .. /S) series are available as single (stand-alone) bearings or single, universally matchable bearings. When ordering single bearings, indicate the number of individual bearings required.

Single bearings

Single bearings are intended for arrangements where only one bearing is used in each bearing position.

Although the widths of the bearing rings are made to very tight tolerances, these bearings are not suitable for mounting immediately adjacent to each other.

Single, universally matchable bearings

Universally matchable bearings are specifically manufactured so that when mounted in random order, but immediately adjacent to each other, a given preload and/or even load distribution is obtained without the use of shims or similar devices. These bearings can be mounted in random order for any desired bearing arrangement.

Single, universally matchable bearings are identified by the designation suffix G (U).

Bearing sets

SKF bearings in the S719 .. B (HB .. /S) and S70 .. B (HX .. /S) series are available as matched bearing sets or as sets of universally matchable bearings. When ordering bearing sets, indicate the number of bearing sets required (the number of individual bearings per set is specified in the designation).

Matched bearing sets

Bearings can be supplied as complete bearing sets consisting of two, three or four bearings. The bearings are matched to each other during production so that when mounted immediately adjacent to each other, in a specified order, a given preload and/or even load distribution is obtained without the use of shims or similar devices. The bore and outside diameters of these bearings are matched to within a maximum of one-third of the applicable permitted diameter tolerance, resulting in an even better load distribution when mounted, compared to single, universally matchable bearings.

Sets of universally matchable bearings

The bearings in these sets can be mounted in random order for any desired bearing arrangement. The bore and outside diameters of universally matchable bearings in a set are matched to within a maximum of one-third of the applicable permitted diameter tolerance, resulting in an even better load distribution when mounted, compared to single, universally matchable bearings.

Like single, universally matchable bearings, sets of universally matchable bearings are identified by the designation suffix G (U), but their positions in the designation differ (→ **table 15, pages 32 and 33**).

Table 1

Example of the ordering possibilities for a three-bearing arrangement

Design criteria	What to order	Bearing designation ¹⁾	Order example
Bearing arrangement is not known	Three single, universally matchable bearings	S719 .. BG../P4A (HB .. /S 7CE .. U.)	3 x S71914 CBGA/P4A (3 x HB70 /S 7CE1 UL)
Bearing arrangement is not known and improved load distribution is desirable	A set of three universally matchable bearings	S719 .. B/P4ATG.. (HB .. /S 7CE .. TU..)	1 x S71914 CB/P4ATGA (1 x HB70 /S 7CE1 TUL)
Bearing arrangement is known	Three bearings in a matched set	S719 .. B/P4AT.. (HB .. /S 7CE .. T..)	1 x S71914 CB/P4ATBTA (1 x HB70 /S 7CE1 TDL)

¹⁾ For additional information about designations, refer to **table 15** on **pages 32 and 33**.

Type of arrangement

Universally matchable bearings and matched bearing sets can be arranged in various combinations depending on the stiffness, rigidity and load requirements of the application. The possible combinations are shown in **fig. 1**, including the designation suffixes applicable to matched bearing sets.

Back-to-back bearing arrangement

In a back-to-back bearing arrangement, the load lines diverge toward the bearing axis. Axial loads acting in both directions can be accommodated, but only by one bearing or bearing set in one direction each. Bearings mounted back-to-back provide a relatively rigid bearing arrangement that can also accommodate tilting moments.

Face-to-face bearing arrangement

In a face-to-face bearing arrangement, the load lines converge toward the bearing axis. Axial loads acting in both directions can be accommodated, but only by one bearing or bearing set in one direction each. Face-to-face arrangements can accommodate small amounts of deflection.

Tandem bearing arrangement

In a tandem bearing arrangement, the load lines are parallel so that radial and axial loads are shared equally by the bearings in the set. The bearing set can only accommodate axial loads acting in one direction. If axial loads act in the opposite direction, or if combined loads are present, additional bearing(s) adjusted against the tandem arrangement should be added.

Bearing sets with 2 bearings

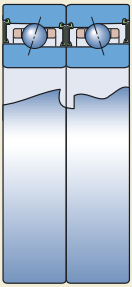

Back-to-back arrangement
Designation suffix DB (*DD*)

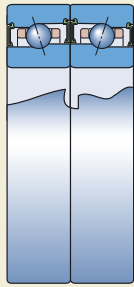

Face-to-face arrangement
Designation suffix DF (*FF*)

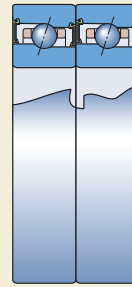

Tandem arrangement
Designation suffix DT (*T*)

Bearing sets with 3 bearings

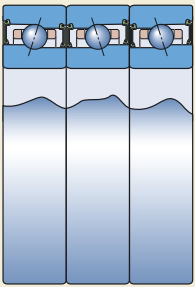

Back-to-back and tandem arrangement
Designation suffix TBT (*TD*)

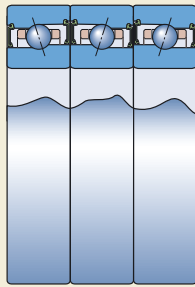

Face-to-face and tandem arrangement
Designation suffix TFT (*TF*)



Tandem arrangement
Designation suffix TT (*3T*)

Bearing sets with 4 bearings

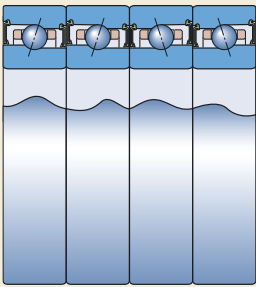

Tandem back-to-back arrangement
Designation suffix QBC (*TDT*)

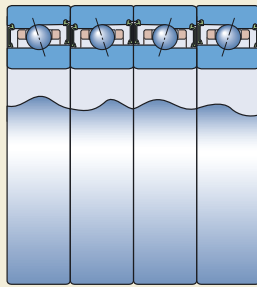

Tandem face-to-face arrangement
Designation suffix QFC (*TFT*)

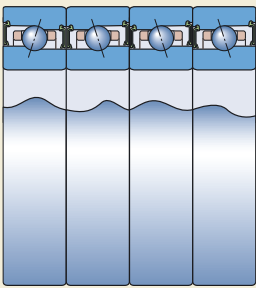

Back-to-back and tandem arrangement
Designation suffix QBT (*3TD*)

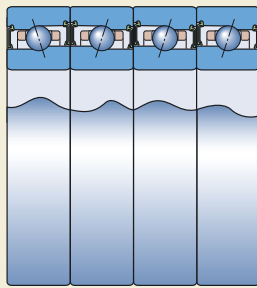

Face-to-face and tandem arrangement
Designation suffix QFT (*3TF*)

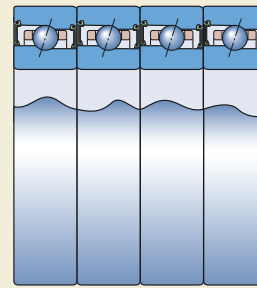

Tandem arrangement
Designation suffix QT (*4T*)

Application examples

Sealed super-precision angular contact ball bearings are common in, but not limited to, machine tool applications. Depending on the type of machine tool and its intended purpose, spindles may have different requirements regarding bearing arrangements.

In high-speed machine tool applications, the spindle is often driven directly by a motor. The spindle is then referred to as a motorized spindle or electro-spindle. As there are only very light radial loads at the non-tool end of this type of spindle, (compared with a belt-driven spindle), sets of super-precision angular contact ball bearings are frequently used.

For any precision application, there is an optimal arrangement to provide the best possible combination of rigidity, load carrying capacity, heat generation and bearing service life.

Electro-spindle in an internal grinding machine

In an internal grinding machine, where speeds are high and a high degree of rigidity is required, two pairs of sealed super-precision angular contact ball bearings mounted back-to-back, e.g. S7014 CB/P4ADT (HX70 /S 7CE1 T) and S71910 CB/P4ADT (HB50 /S 7CE1 T), and preloaded with springs at the non-tool end of the spindle, are suitable.

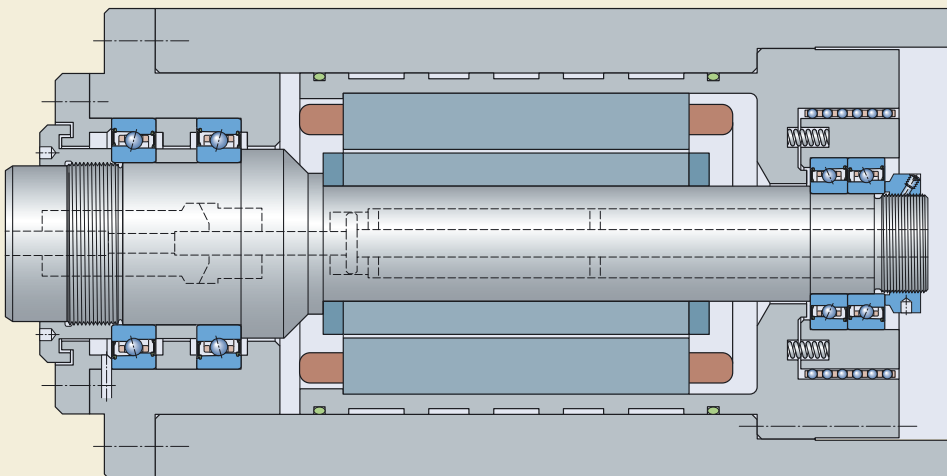

Electro-spindle in a high-speed milling machine

In the contaminated environment of a high-speed milling machine, where a high degree of rigidity is required and radial space is limited, two sets of matched back-to-back sealed hybrid super-precision angular contact ball bearings, e.g. S7014 ACB/HCP4ADBB (HX70 /S/NS 7CE3 DDM) and S7012 ACB/HCP4ADBB (HX60 /S/NS 7CE3 DDM), each incorporating a set of precision-matched spacer rings, can be used.

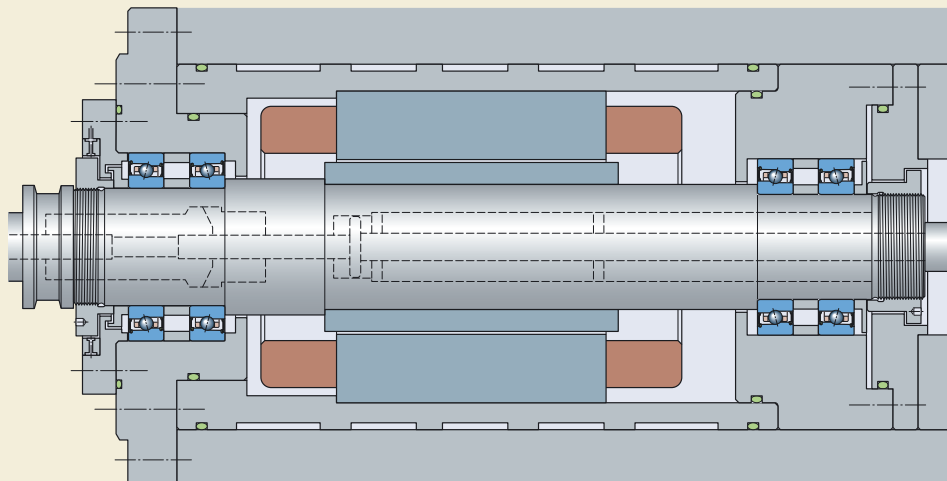

Electro-spindle in a high-speed metal cutting machine

For oil lubricated metal cutting spindles, where speeds are exceptionally high and loads are light, a back-to-back arrangement of open super-precision angular contact ball bearings, e.g. 7020 ACB/P4ALDT (HX100 /GH 7CE3 T) and 7016 ACB/P4AL (HX80 /GH 7CE3), incorporating a set of precision-matched spacer rings at the tool end, can be used.

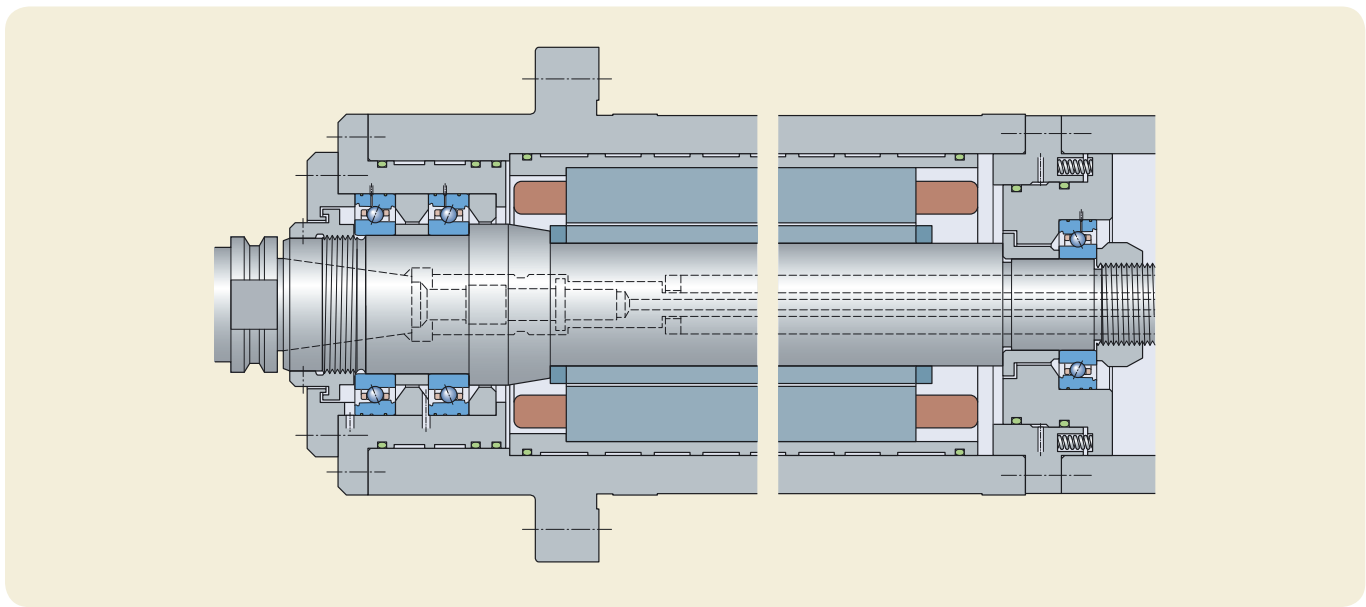

Milling head spindle

For a milling head spindle, where speeds are high and a high degree of rigidity is required, a set of three universally matchable sealed hybrid super-precision angular contact ball bearings, e.g. S71914 ACBGA/HCP4A (HB70 /S/NS 7CE3 UL), can be used.

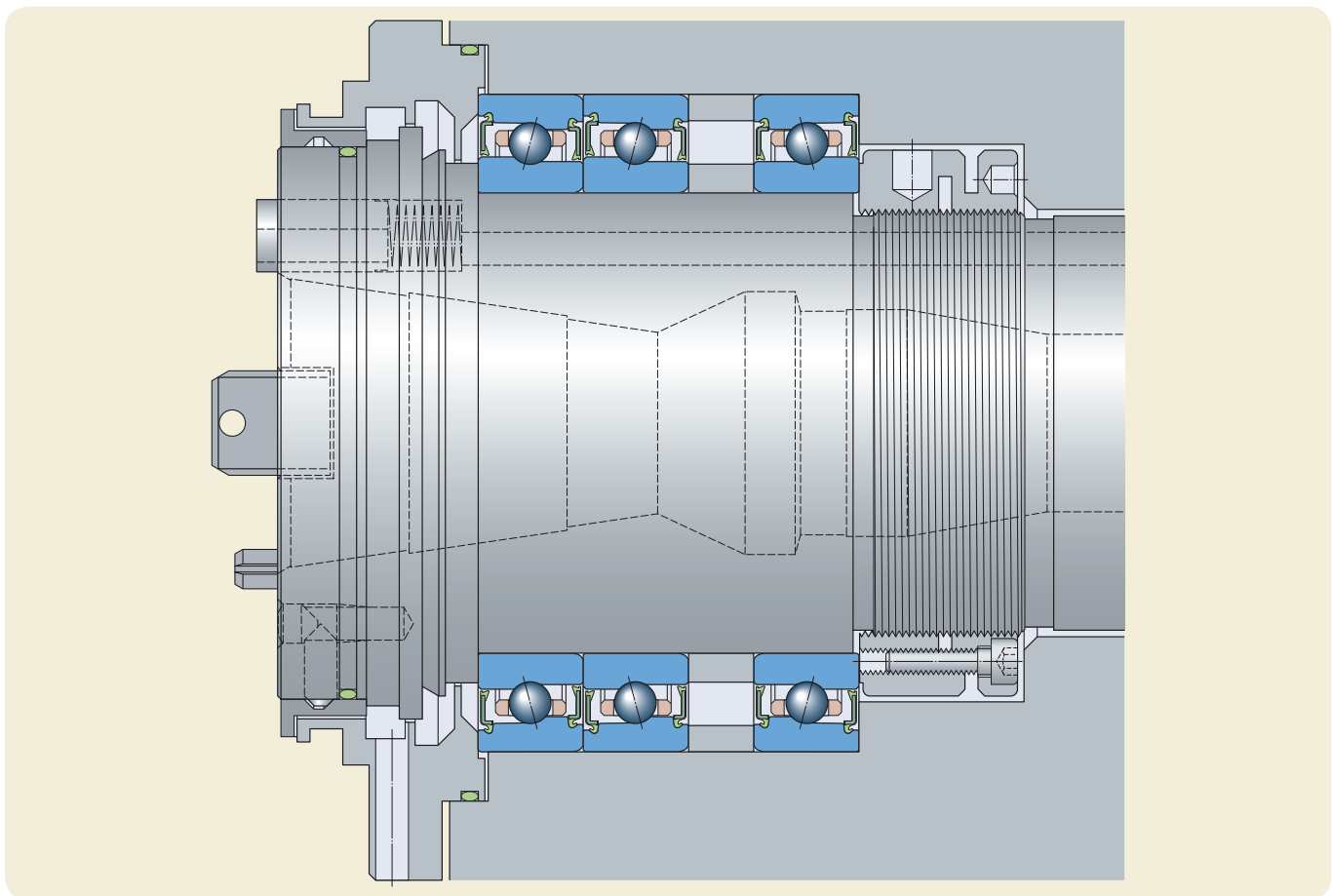

Lubrication and maintenance

Heat resulting from friction is a constant threat to production equipment. One way to reduce heat and the wear associated with friction, particularly in bearings, is to be sure that the correct quantity of the appropriate lubricant reaches all moving parts.

For an adequate lubricant film to be formed between the balls and raceways of super-precision angular contact ball bearings, only a very small amount of lubricant is required. With grease lubrication, the hydrodynamic friction losses are small and operating temperatures can be kept to a minimum. However, where speeds are constantly very high (generally, speed factor $A > 1\,800\,000$ mm/min), the bearings should be lubricated with oil, as the service life of grease is too short under these conditions and oil provides the added benefit of cooling.

Table 1

Technical specifications of the grease in sealed bearings

Properties	Grease specification
Thickener	Special lithium soap
Base oil type	Ester/PAO
NLGI consistency class	2
Temperature range [°C] [°F]	-40 to +120 -40 to +250
Kinematic viscosity [mm ² /s] at 40 °C at 100 °C	25 6

Sealed bearings

SKF sealed bearings in the S719 .. B (HB .. /S) and S70 .. B (HX .. /S) series are relubrication-free under normal operating conditions. They are filled with a high-grade, low viscosity grease as standard. The grease is characterized by:

- high-speed capability (speed factor A up to 1 600 000 mm/min)
- excellent ageing resistance
- very good rust inhibiting properties

The technical specifications of the grease are provided in **table 1**. The quantity of grease fills approximately 15% of the free space in the bearing.

Grease lubrication for open bearings

In most applications with open bearings in the 719 .. B (HB) and 70 .. B (HX) series, grease with a mineral base oil and lithium thickener is suitable. These greases adhere well to the bearing surfaces and are suitable for operating temperatures ranging from -30 to +100 °C. For bearing arrangements that operate at very high speeds and temperatures, and where long service life is required, the use of grease based on a synthetic oil, e.g. the diester oil based grease SKF LGLT 2, has been proven effective.

Table 2

Reference grease quantity for initial grease fill estimation

Bearing Bore diameter d	Size	Reference grease quantity ¹⁾ for open bearings in the series	
		719 .. B (HB) G _{ref}	70 .. B (HX)
mm	–	cm ³	
30	06	0,7	1,4
35	07	1,0	1,8
40	08	1,4	2,2
45	09	1,8	2,9
50	10	1,9	3,1
55	11	2,6	4,7
60	12	2,8	5,0
65	13	3,0	5,5
70	14	4,5	7,3
75	15	4,8	7,7
80	16	5,3	10,5
85	17	6,5	11,0
90	18	7,4	14,1
95	19	7,5	14,7
100	20	10,0	15,3
110	22	11,4	22,3
120	24	14,0	23,7

¹⁾ Refers to a 30% filling grade.

Initial grease fill

In high-speed applications, less than 30% of the free space in the bearings should be filled with grease. The initial grease fill depends on the bearing series and size as well as the speed factor, which is

$$A = n d_m$$

where

A = speed factor [mm/min]

n = rotational speed [r/min]

d_m = bearing mean diameter
= 0,5 (d + D) [mm]

The initial grease fill for open bearings can be estimated by

$$G = K G_{ref}$$

where

G = initial grease fill [cm³]

K = a calculation factor dependent on the speed factor A (→ **diagram 1**)

G_{ref} = reference grease quantity (→ **table 2**) [cm³]

Running-in of sealed and open, grease lubricated bearings

A grease lubricated super-precision bearing will initially run with a relatively high frictional moment. If the bearing is run at high speed without a running-in period, the tem-

perature rise can be considerable. The relatively high frictional moment is due to the churning of the grease and it takes time for the excess grease to work its way out of the contact zone. For open bearings, this time period can be minimized by applying a small quantity of grease distributed evenly on both sides of the bearing during the assembly stage. Spacers between two adjacent

Diagram 1

Factor K for initial grease fill estimation

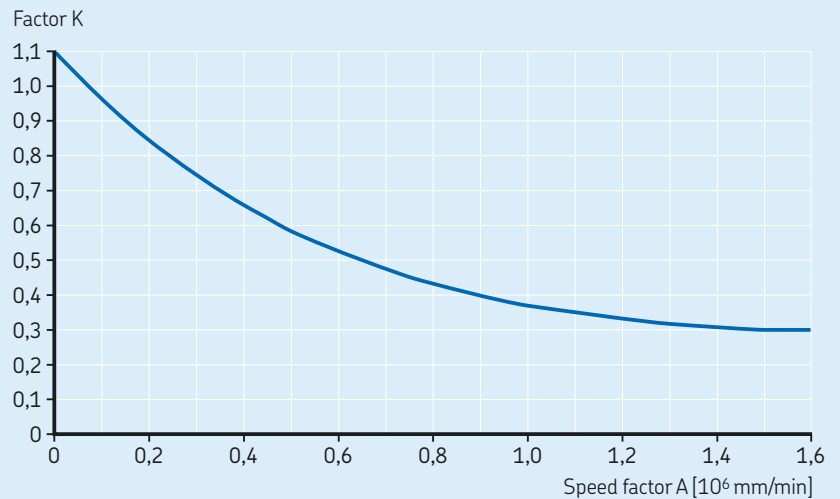
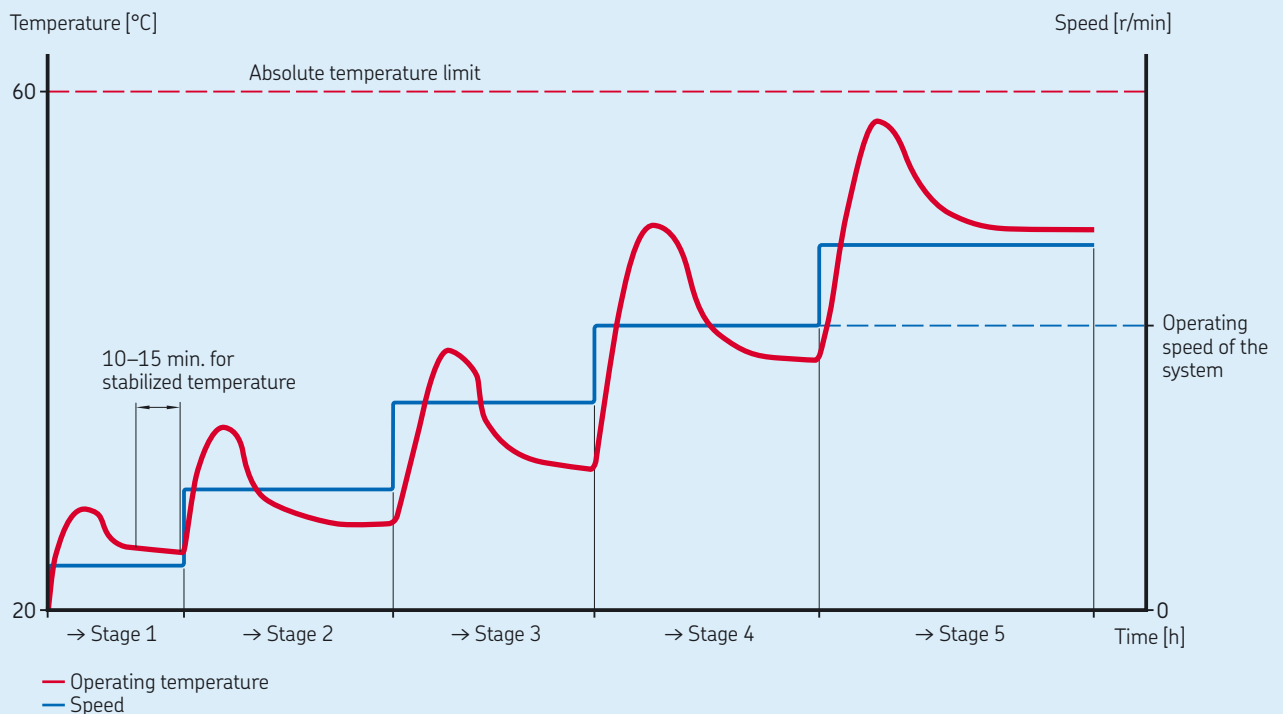

Diagram 2

Graphic representation of a running-in procedure



bearings are also beneficial (→ *Adjusting preload with spacer rings*, page 24).

The time required to stabilize the operating temperature depends on a number of factors – the type of grease, the initial grease fill, how the grease is applied to the bearings, and the running-in procedure (→ **diagram 2** on page 17).

Super-precision bearings can typically operate with minimal lubricant quantity when properly run-in, enabling the lowest frictional moment and temperature to be achieved. The grease that collects at the sides of the bearing will act as a reservoir and the oil can bleed into the raceways to provide efficient lubrication for a long time.

Running-in can be done in several ways. Wherever possible and regardless of the procedure chosen, running-in should involve operating the bearing in both a clockwise and anticlockwise direction.

The standard running-in procedure can be summarized as follows:

- 1 Select a low starting speed and a relatively small speed increment interval.
- 2 Decide on an absolute temperature limit, usually 60 to 65 °C. It is advisable to set the equipment with limit switches that will stop the equipment if the temperature rise exceeds the set limit.
- 3 Start operation at the chosen initial speed.
- 4 Monitor the temperature by taking measurements at the bearing outer ring position, avoiding peaks, and wait for it to stabilize. If the temperature reaches the limit, stop operation and allow the bearing to cool. Start again at the same speed and wait for the temperature to stabilize.
- 5 Increase the speed by one interval and repeat **step 4**.
- 6 Continue increasing the speed in intervals, allowing the temperature to stabilize below the limit at each stage. Proceed until this is achieved for one speed interval greater than the operating speed of the system. This results in a lower temperature rise during normal operation. The bearing is now properly run-in.

The standard running-in procedure is time-consuming and can take as long as 8 to 10 hours.

The short running-in procedure reduces the number of stages. Although each stage may have to be repeated several times, each cycle is just a few minutes long, and the total time for this running-in process is substantially shorter than the standard procedure.

The main steps of the short running-in procedure can be summarized as follows:

- 1 Select a starting speed approximately 20 to 25% of the attainable speed and choose a relatively large speed increment interval.
- 2 Decide on an absolute temperature limit, usually 60 to 65 °C. It is advisable to set the equipment with limit switches that will stop the equipment if the temperature rise exceeds the set limit.
- 3 Start operation at the chosen initial speed.
- 4 Monitor the temperature by taking measurements at the bearing outer ring position until the temperature reaches the limit. Care should be taken as the temperature increase may be very rapid.
- 5 Stop operation and let the outer ring of the bearing cool down by 5 to 10 °C.
- 6 Start operation at the same speed a second time and monitor the temperature until the limit is reached again.
- 7 Repeat **steps 5** and **6** until the temperature stabilizes below the limit. When the temperature peak is lower than the alarm limit, the bearing is run-in at that particular speed.
- 8 Increase the speed by one interval and repeat **steps 4** to **7**.
- 9 Repeat the running-in process until the bearing is running at one speed interval higher than the operating speed of the system. This results in a lower temperature rise during normal operation. The bearing is now properly run-in.

Oil lubrication for open bearings

Oil lubrication is recommended for open bearings in the 719 .. B (HB) and 70 .. B (HX) series in applications where very high speeds (generally, speed factor $A > 1\,800\,000$ mm/min) preclude the use of grease lubricated bearings.

Oil-air lubrication method

In some precision applications, the very high operational speeds and requisite low operating temperatures generally require an oil-air lubrication system. With the oil-air method, also called the oil-spot method, accurately metered quantities of oil are directed at each individual bearing by compressed air. For bearings used in sets, each bearing is supplied by a separate oil injector. Most designs include special spacers that incorporate the oil nozzles.

Guidelines for the quantity of oil to be supplied to each bearing for very high speed operation can be obtained from

$$Q = 1,3 d_m$$

where

Q = oil flow rate [mm³/h]

d_m = bearing mean diameter
= $0,5 (d + D)$ [mm]

The calculated oil flow rate should be verified during operation and adjusted, depending on the resulting temperatures.

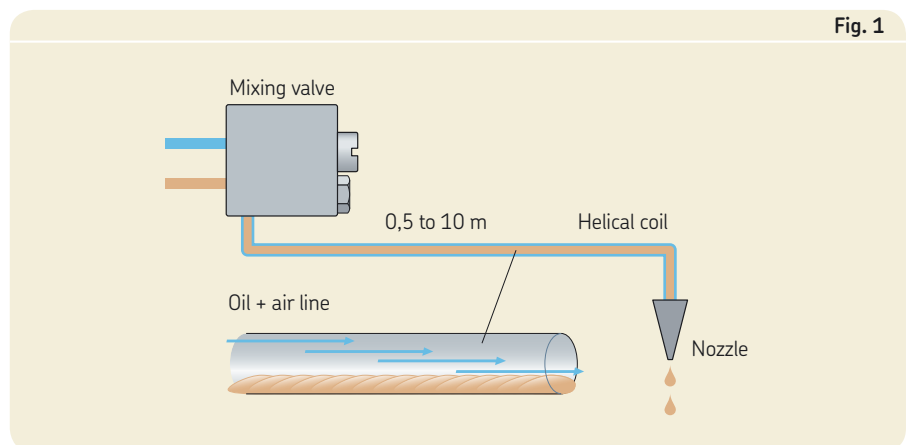

Fig. 1

Oil is supplied to the feed lines at given intervals by a metering unit. The oil coats the inside surface of the feed lines and “creeps” toward the nozzles (→ **fig. 1**), where it is delivered to the bearings. The oil nozzles should be positioned correctly (→ **table 3**) to make sure that the oil is introduced into the contact area between the balls and raceways and to avoid interference with the cage.

High quality lubricating oils without EP additives are generally recommended for super-precision angular contact ball bearings. Oils with a viscosity of 40 to 100 mm²/s at 40 °C are typically used. A filter that prevents particles > 5 µm from reaching the bearings should also be incorporated.

Open bearings for direct oil lubrication

When a minimal amount of lubricant is to be supplied directly and safely through the outer ring, open bearings with an annular groove and two lubrication holes in the outer ring are recommended (→ **fig. 2**). To prevent oil from leaking between the bearing outside diameter and the housing bore, the cylindrical surface of the outer ring has two additional annular grooves to accommodate O-rings.

This bearing variant is identified by the designation suffix L (GH) and is available for bearings with a bore diameter $d \geq 40$ mm.

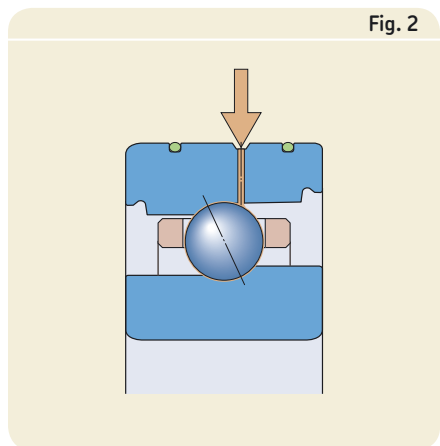
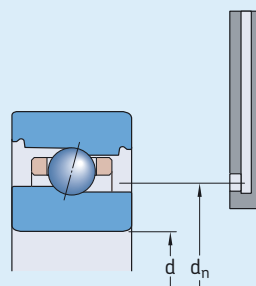

Fig. 2

Table 3

Oil nozzle position for oil-air lubrication



Bearing Bore diameter d	Size	Oil nozzle position for open bearings in the series	
		719 .. B (HB) d _n	70 .. B (HX)
mm	–	mm	
30	06	36,6	40
35	07	43	46,1
40	08	49,1	51,6
45	09	54,2	57,2
50	10	58,7	61,8
55	11	64,8	69,2
60	12	69,8	74,2
65	13	74,8	79
70	14	81,9	86,1
75	15	86,9	91,1
80	16	91,7	98
85	17	99,2	103
90	18	103,9	110
95	19	109	115
100	20	116,1	120
110	22	125,7	134,6
120	24	138,2	144,7

Bearing data – general

Boundary dimensions

The boundary dimensions of SKF super-precision angular contact ball bearings are in accordance with ISO 15:2011:

- Boundary dimensions of bearings in the S719 .. B (HB .. /S) series are in accordance with ISO dimensions series 19.
- Boundary dimensions of bearings in the S70 .. B (HX .. /S) series are in accordance with ISO dimensions series 10.

Chamfer dimensions

Minimum values for the chamfer dimensions in the radial direction (r_1, r_3) and the axial direction (r_2, r_4) are provided in the product tables. The values for the chamfers on the inner ring and thrust side of the outer ring are in accordance with ISO 15:2011. The values for the non-thrust side of the outer ring are smaller than those on the thrust side.

The appropriate maximum chamfer limits are in accordance with ISO 582:1995.

Tolerances

SKF bearings in the S719 .. B (HB .. /S) and S70 .. B (HX .. /S) series are manufactured, standard, to P4A tolerance class. On request, bearings can be supplied to the higher precision PA9A tolerance class.

The tolerance values are listed as follows:

- P4A (better than ABEC 7) tolerance class in **table 1**
- PA9A (better than ABEC 9) tolerance class in **table 2**

Table 1

Class P4A tolerances

Inner ring		Δ_{dmp}		Δ_{ds}		V_{dp}	V_{dmp}	Δ_{Bs}		Δ_{B1s}		V_{Bs}	K_{ia}	S_d	S_{ia}
over	incl.	high	low	high	low	max	max	high	low	high	low	max	max	max	max
mm		μm		μm		μm	μm	μm		μm		μm	μm	μm	μm
18	30	0	-5	0	-5	1,5	1	0	-120	0	-250	1,5	2,5	1,5	2,5
30	50	0	-6	0	-6	1,5	1	0	-120	0	-250	1,5	2,5	1,5	2,5
50	80	0	-7	0	-7	2	1,5	0	-150	0	-250	1,5	2,5	1,5	2,5
80	120	0	-8	0	-8	2,5	1,5	0	-200	0	-380	2,5	2,5	2,5	2,5

Outer ring		Δ_{Dmp}		Δ_{Ds}		V_{Dp}	V_{Dmp}	$\Delta_{Cs}, \Delta_{C1s}$		V_{Cs}	K_{ea}	S_D	S_{ea}
over	incl.	high	low	high	low	max	max			max	max	max	max
mm		μm		μm		μm	μm			μm	μm	μm	μm
30	50	0	-6	0	-6	2	1,5	Values are identical to those for the inner ring of the same bearing ($\Delta_{Bs}, \Delta_{B1s}$)		1,5	2,5	1,5	2,5
50	80	0	-7	0	-7	2	1,5			1,5	4	1,5	4
80	120	0	-8	0	-8	2,5	1,5			2,5	5	2,5	5
120	150	0	-9	0	-9	4	1,5			2,5	5	2,5	5
150	180	0	-10	0	-10	6	3			4	6	4	6

Bearing preload

A single super-precision angular contact ball bearing does not have any preload. Preload can only be obtained when one bearing is placed against another to provide location in the opposite direction.

Preload in sets of universally matchable bearings and matched bearing sets prior to mounting

Universally matchable bearings and matched bearing sets are manufactured so that when the bearings are placed against each other, prior to mounting, a certain preload will result.

To meet the varying requirements regarding rotational speed and rigidity, SKF bearings in the S719 .. B (HB .. /S) and S70 .. B (HX .. /S) series are produced to different preload classes:

- class A (L), light preload
- class B (M), moderate preload
- class C (F), heavy preload

The preload level depends on the bearing series, the contact angle and the size of the bearing, and applies to bearing sets with two bearings arranged back-to-back or face-to-face as listed in **table 3** on **page 22**.

Bearing sets consisting of three or four bearings have a heavier preload than sets with two bearings. The preload for these bearing sets is obtained by multiplying the

values listed in **table 3** on **page 22** by a factor of:

- 1,35 for TBT (TD) and TFT (TF) arrangements
- 1,6 for QBT (3TD) and QFT (3TF) arrangements
- 2 for QBC (TDT) and QFC (TFT) arrangements

Bearing sets with a special preload can be supplied on request. These bearing sets are identified by the designation suffix G followed by a number. The number is the mean preload value of the set expressed in daN. Special preload is not applicable for sets of universally matchable bearings consisting of three or more bearings (suffixes TG and QG).



Table 2

Class PA9A tolerances

Inner ring		Δ_{dmp}		Δ_{ds}		V_{dp}	V_{dmp}	Δ_{Bs}		Δ_{B1s}		V_{Bs}	K_{ia}	S_d	S_{ia}
over	incl.	high	low	high	low	max	max	high	low	high	low	max	max	max	max
mm		μm		μm		μm	μm	μm		μm		μm	μm	μm	μm
18	30	0	-2,5	0	-2,5	1,5	1	0	-120	0	-250	1,5	2,5	1,5	2,5
30	50	0	-2,5	0	-2,5	1,5	1	0	-120	0	-250	1,5	2,5	1,5	2,5
50	80	0	-4	0	-4	2	1,5	0	-150	0	-250	1,5	2,5	1,5	2,5
80	120	0	-5	0	-5	2,5	1,5	0	-200	0	-380	2,5	2,5	2,5	2,5

Outer ring		Δ_{Dmp}		Δ_{Ds}		V_{Dp}	V_{Dmp}	$\Delta_{Cs}, \Delta_{C1s}$		V_{Cs}	K_{ea}	S_D	S_{ea}
over	incl.	high	low	high	low	max	max			max	max	max	max
mm		μm		μm		μm	μm			μm	μm	μm	μm
30	50	0	-4	0	-4	2	1,5	Values are identical to those for the inner ring of the same bearing ($\Delta_{Bs}, \Delta_{B1s}$)		1,5	2,5	1,5	2,5
50	80	0	-4	0	-4	2	1,5			1,5	4	1,5	4
80	120	0	-5	0	-5	2,5	1,5			2,5	5	2,5	5
120	150	0	-5	0	-5	2,5	1,5			2,5	5	2,5	5
150	180	0	-7	0	-7	4	3			2,5	5	2,5	5

Preload in mounted bearing sets

Sets of universally matchable bearings and matched bearing sets have a heavier preload when mounted compared to the built-in preload, predetermined during manufacture. The increase in preload depends mainly on the actual tolerances for the bearing seats on the shaft and in the housing bore. An increase in preload can also be caused by deviations from the geometrical form of associated components such as cylindricity, perpendicularity or concentricity of the bearing seats.

During operation, an increase in preload is also caused by:

- the rotational speed of the shaft for constant position arrangements
- temperature gradients between the inner ring, outer ring and balls
- different coefficient of thermal expansion for the shaft and housing materials compared to the bearing steel

If the bearings are mounted with zero interference on a steel shaft and in a thick-walled steel or cast iron housing, preload can be determined with sufficient accuracy from

$$G_m = f f_1 f_2 f_{HC} G_{A,B,C}$$

where

- G_m = preload in the mounted bearing set [N]
- $G_{A,B,C}$ = built-in preload in the bearing set, prior to mounting (→ table 3) [N]
- f = a bearing factor dependent on the bearing series and size (→ table 4)
- f_1 = a correction factor dependent on the contact angle (→ table 5)
- f_2 = a correction factor dependent on the preload class (→ table 5)
- f_{HC} = a correction factor for hybrid bearings (→ table 5)

Considerably tighter fits may be necessary, for example for very high speed spindles, where centrifugal forces can loosen the inner ring from its seat on the shaft. These bearing arrangements must be carefully evaluated.

Table 3

Axial preload of universally matchable bearings and matched bearing pairs, prior to mounting, arranged back-to-back or face-to-face

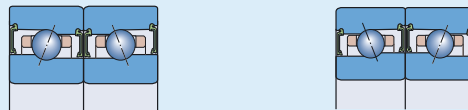

Bearing Bore diameter d	Size	Axial preload of bearings in the series ¹⁾			S719 ACB (HB/S CE3) S719 ACB/HC (HB/S/NS CE3) for preload class			S70 CB (HX/S CE1) S70 CB /HC (HX/S/NS CE1) for preload class			S70 ACB (HX/S CE3) S70 ACB/HC (HX/S/NS CE3) for preload class		
		A	B	C	A	B	C	A	B	C	A	B	C
mm	–	N											
30	06	16	32	96	27	54	160	21	42	125	36	72	215
35	07	17	34	100	29	58	175	23	46	140	38	76	230
40	08	18	36	110	31	62	185	24	48	145	41	82	245
45	09	24	48	145	41	82	245	31	62	185	54	110	330
50	10	26	52	155	43	86	260	33	66	200	56	110	330
55	11	33	66	200	55	110	330	46	92	275	78	155	470
60	12	34	68	205	57	115	340	48	96	290	80	160	480
65	13	35	70	210	60	120	360	49	98	295	85	170	510
70	14	45	90	270	75	150	450	64	130	390	110	220	660
75	15	46	92	275	80	160	480	65	130	390	115	230	690
80	16	52	105	310	87	175	520	78	155	470	150	300	900
85	17	54	110	325	93	185	560	80	160	480	150	300	900
90	18	59	120	355	100	200	600	92	185	550	160	320	960
95	19	60	120	360	105	210	630	94	190	570	165	330	990
100	20	72	145	430	125	250	750	96	190	570	165	330	990
110	22	86	170	515	145	290	870	125	250	750	210	420	1 260
120	24	90	180	540	155	310	930	130	260	780	220	440	1 320

¹⁾ Data is also applicable to open bearings. Data for bearings with an 18° contact angle is available on request.

Preload with constant force

In precision, high-speed applications, a constant and uniform preload is important. To maintain the proper preload, calibrated linear springs can be used between one bearing outer ring and its housing shoulder (→ **fig. 1**). With springs, the kinematic behaviour of the bearing will not influence preload under normal operating conditions. Note, however, that a spring-loaded bearing arrangement has a lower degree of rigidity than an arrangement using axial displacement to set the preload.

Preload by axial displacement

Rigidity and precise axial guidance are critical parameters in bearing arrangements, especially when alternating axial forces occur. In these cases, the preload in the bearings is usually obtained by adjusting the bearing rings relative to each other in the axial direction. This preload method offers significant benefits in terms of system rigidity. However, depending on the bearing series, contact angle and ball material, preload increases considerably with rotational speed.

Universally matchable bearings and matched bearing sets are manufactured so that when mounted properly, they will attain their predetermined axial displacement and consequently the proper preload. With single bearings, precision-matched spacer rings must be used.

Fig. 1

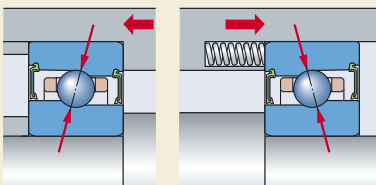

Table 4

Bearing factor f for calculating the preload in mounted bearing sets

Bearing Bore diameter	Size	Bearing factor f for bearings in the series ¹⁾	
		S719 .. B (HB .. /S)	S70 .. B (HX .. /S)
d			
mm	–	–	–
30	06	1,07	1,03
35	07	1,06	1,04
40	08	1,06	1,04
45	09	1,08	1,05
50	10	1,09	1,06
55	11	1,09	1,06
60	12	1,11	1,06
65	13	1,13	1,07
70	14	1,1	1,07
75	15	1,11	1,08
80	16	1,13	1,07
85	17	1,11	1,08
90	18	1,12	1,07
95	19	1,13	1,07
100	20	1,11	1,08
110	22	1,14	1,07
120	24	1,13	1,08

¹⁾ Data is also applicable to open bearings.

Table 5

Correction factors for calculating the preload in mounted bearing sets

Bearing series ¹⁾	Correction factors				f_{HC}
	f_1	f_2 for preload class			
		A	B	C	
S719 CB (HB .. /S CE1)	1	1	1,02	1,07	1
S719 ACB (HB .. /S CE3)	0,99	1	1,02	1,07	1
S719 CB/HC (HB .. /S/NS CE1)	1	1	1,03	1,08	1,01
S719 ACB/HC (HB .. /S/NS CE3)	0,99	1	1,02	1,08	1,01
S70 CB (HX .. /S CE1)	1	1	1,02	1,05	1
S70 ACB (HX .. /S CE3)	0,99	1	1,01	1,04	1
S70 CB/HC (HX .. /S/NS CE1)	1	1	1,02	1,05	1,01
S70 ACB/HC (HX .. /S/NS CE3)	0,99	1	1,02	1,05	1,01

¹⁾ Data is also applicable to open bearings. Data for bearings with an 18° contact angle is available on request.

Adjusting preload with spacer rings

By placing precision-matched spacer rings between two bearings, it is possible to increase or decrease preload. Precision-matched spacer rings can also be used to

- increase system rigidity
- create a sufficiently large grease reservoir between two bearings
- create a space for oil-air lubrication nozzles

It is possible to adjust preload in a bearing set, by grinding the side face of the inner or outer spacer ring. **Table 6** provides informa-

tion about which of the equal-width spacer ring side faces must be ground and what effect it will have. Guideline values for the requisite overall width reduction of the spacer rings are listed in **table 7**.

To achieve maximum bearing performance, the spacer rings must not deform under load. They should be made of high-grade steel that can be hardened to between 45 and 60 HRC. Particular importance must be given to the plane parallelism of the side face surfaces, where the permissible shape deviation must not exceed 1 to 2 μm .

Table 6

Guidelines for spacer ring modification

Preload change of a bearing set	Width reduction Value	Requisite spacer ring between bearings arranged	
		back-to-back	face-to-face
Increasing the preload			
from A to B	a	inner	outer
from B to C	b	inner	outer
from A to C	a + b	inner	outer
Decreasing the preload			
from B to A	a	outer	inner
from C to B	b	outer	inner
from C to A	a + b	outer	inner

Table 7

Guideline values for spacer ring width reduction

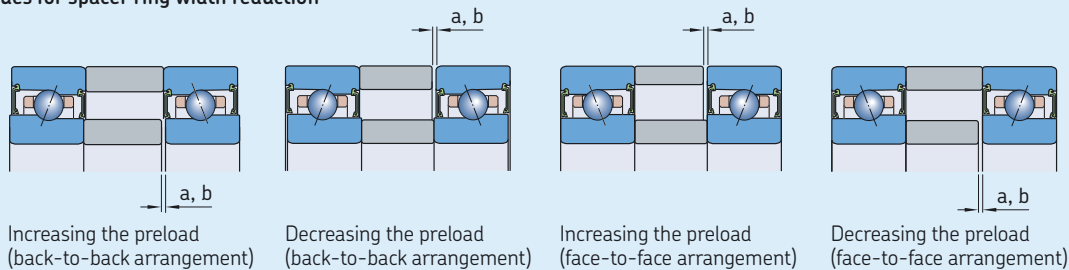

Bearing Bore diameter d	Size	Requisite spacer ring width reduction for bearings in the series ¹⁾							
		S719 CB (HB/S CE1)		S719 ACB (HB/S CE3)		S70 CB (HX/S CE1)		S70 ACB (HX/S CE3)	
		a	b	a	b	a	b	a	b
mm	–	μm							
30	06	3	8	2	6	3	10	2	7
35	07	3	8	2	6	3	10	2	7
40	08	3	8	2	6	3	10	2	7
45	09	3	9	2	6	4	10	3	7
50	10	3	9	2	6	4	11	3	7
55	11	4	11	2	7	4	12	3	9
60	12	4	11	2	7	4	13	3	9
65	13	4	11	2	7	5	13	3	9
70	14	4	12	3	8	5	15	3	10
75	15	4	12	3	8	5	15	3	10
80	16	4	12	3	8	6	16	4	12
85	17	4	12	3	8	6	16	4	12
90	18	5	13	3	9	7	18	4	13
95	19	5	13	3	9	7	18	4	13
100	20	5	14	3	9	7	18	4	13
110	22	5	16	4	10	7	19	4	13
120	24	5	16	4	10	7	19	4	13

¹⁾ Data is also applicable to open bearings. Data for bearings with an 18° contact angle is available on request.

Effect of rotational speed on preload

Using strain gauges, SKF has determined that there is a marked increase in preload at very high speeds. This is mainly attributable to the heavy centrifugal forces on the balls causing them to change their position within the bearing. When compared to an all-steel bearing, a hybrid bearing can attain much higher rotational speeds without significantly increasing preload. This is due to the lower mass of the balls.

Bearing axial stiffness

Axial stiffness depends on the deformation of the bearing under load and can be expressed as the ratio of the load to bearing resilience. However, since the resilience of rolling bearings does not depend linearly on the load, axial stiffness is also load-dependent. Exact values of axial stiffness, for SKF bearings in the S719 .. B (HB .. /S) and S70 .. B (HX .. /S) series, for a given preload can be calculated using advanced computer methods, but guideline values are listed in **table 8**. These values apply to mounted bearing sets under static conditions with two all-steel bearings arranged back-to-back or face-to-face and subjected to moderate loads.

Bearing sets comprising three or four bearings can provide a higher degree of axial stiffness than sets with two bearings. The axial stiffness for these sets can be calculated by multiplying the values listed in **table 8** by a factor dependent on the bearing arrangement and preload class of the bearings:

- 1,45 for TBT (TD) and TFT (TF) arrangements
- 1,8 for QBT (3TD) and QFT (3TF) arrangements
- 2 for QBC (TDT) and QFC (TFT) arrangements

For hybrid bearings, the axial stiffness can be calculated in the same way as for all-steel bearings. However, the calculated value should then be multiplied by a factor of 1,11 (for all arrangements and preload classes).

Table 8

Static axial stiffness for bearing pairs arranged back-to-back or face-to-face

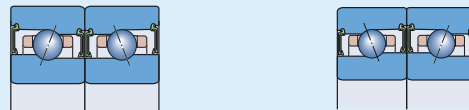

Bearing Bore diameter d	Size	Static axial stiffness of all-steel bearings in the series ¹⁾											
		S719 CB (HB/S CE1) for preload class			S719 ACB (HB/S CE3) for preload class			S70 CB (HX/S CE1) for preload class			S70 ACB (HX/S CE3) for preload class		
mm	–	A	B	C	A	B	C	A	B	C	A	B	C
		N/μm											
30	06	16	20	33	68	87	130	22	29	46	100	126	190
35	07	17	22	34	74	95	142	25	33	52	106	136	204
40	08	19	24	39	84	107	158	28	36	57	121	158	233
45	09	22	29	47	98	126	190	31	40	64	138	183	280
50	10	24	32	50	102	132	202	33	43	69	147	183	273
55	11	24	32	53	106	136	206	38	50	80	170	215	331
60	12	26	34	54	112	146	214	41	54	86	178	225	338
65	13	27	36	58	122	158	238	41	54	85	185	239	359
70	14	31	39	63	132	167	251	47	63	99	212	268	405
75	15	32	42	68	148	190	287	50	65	104	235	299	451
80	16	33	44	68	140	184	272	52	68	109	278	353	529
85	17	35	47	74	158	201	308	54	71	112	278	353	533
90	18	34	46	72	152	192	294	54	71	112	246	317	480
95	19	36	46	74	164	208	317	56	74	117	258	330	497
100	20	45	60	95	205	266	403	58	76	120	262	337	510
110	22	46	59	96	201	257	392	71	93	147	309	396	597
120	24	49	65	104	225	290	437	75	98	156	333	427	641

¹⁾ Data is also applicable to open bearings. Data for bearings with an 18° contact angle is available on request.

Fitting and clamping of bearing rings

Super-precision angular contact ball bearings are typically located axially on shafts or in housings with either precision lock nuts (→ fig. 2) or end caps. These components require high geometrical precision and good mechanical strength to provide reliable locking.

The tightening torque M_t , for precision lock nuts or end cap bolts, must be sufficient to prevent relative movement of adjacent components, maintain the position of the bearings without deformation, and minimize material fatigue.

Calculating the tightening torque M_t

It is difficult to accurately calculate the tightening torque M_t . The following formulas can be used as guidelines, but the results should be verified during operation.

The axial clamping force for a precision lock nut or the bolts in an end cap is

$$P_a = F_s + (N_{cp}F_c) + G_{A,B,C}$$

The tightening torque for a precision lock nut is

$$M_t = K P_a \\ = K [F_s + (N_{cp}F_c) + G_{A,B,C}]$$

The tightening torque for end cap bolts is

$$M_t = \frac{K P_a}{N_b}$$

$$M_t = \frac{K [F_s + (N_{cp}F_c) + G_{A,B,C}]}{N_b}$$

where

M_t = tightening torque [Nmm]

P_a = axial clamping force [N]

F_s = minimum axial clamping force (→ table 9) [N]

F_c = axial fitting force (→ table 9) [N]

$G_{A,B,C}$ = built-in bearing preload, prior to mounting (→ table 3 on page 22) [N]

N_{cp} = the number of preloaded bearings

N_b = the number of end cap bolts

K = a calculation factor dependent on the thread (→ table 10)

Fig. 2

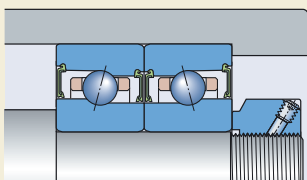

Table 9

Minimum axial clamping force and axial fitting force for precision lock nuts and end caps

Bearing Bore diameter d	Size	Minimum axial clamping force for bearings in the series ¹⁾		Axial fitting force for bearings in the series ¹⁾	
		S719 .. B (HB .. /S) F_s	S70 .. B (HX .. /S)	S719 .. B (HB .. /S) F_c	S70 .. B (HX .. /S)
mm	–	N		N	
30	06	1 900	2 500	300	550
35	07	2 600	3 300	440	750
40	08	3 100	4 100	500	750
45	09	3 800	4 500	480	750
50	10	3 100	5 000	380	650
55	11	4 100	6 000	430	800
60	12	4 500	6 500	400	750
65	13	4 800	7 000	370	700
70	14	6 500	8 500	500	800
75	15	6 500	9 000	480	750
80	16	7 000	11 000	650	1 200
85	17	9 000	11 000	900	1 400
90	18	9 500	16 000	850	1 700
95	19	10 000	14 000	850	1 500
100	20	12 000	15 000	1 000	1 400
110	22	13 000	20 000	900	1 800
120	24	16 000	22 000	1 200	1 900

¹⁾ Data is also applicable to open bearings.

Load carrying capacity of bearing sets

The values listed in the product tables for the basic dynamic load rating C , the basic static load rating C_0 and the fatigue load limit P_u apply to single bearings. For bearing sets, the values for single bearings should be multiplied by a calculation factor according to **table 11**.

Table 10

Factor K for calculating the tightening torque

Nominal thread diameter ¹⁾	Factor K for precision lock nuts	end cap bolts
–	–	–
M 4	–	0,8
M 5	–	1
M 6	–	1,2
M 8	–	1,6
M 10	1,4	2
M 12	1,6	2,4
M 14	1,9	2,7
M 15	2	2,9
M 16	2,1	3,1
M 17	2,2	–
M 20	2,6	–
M 25	3,2	–
M 30	3,9	–
M 35	4,5	–
M 40	5,1	–
M 45	5,8	–
M 50	6,4	–
M 55	7	–
M 60	7,6	–
M 65	8,1	–
M 70	9	–
M 75	9,6	–
M 80	10	–
M 85	11	–
M 90	11	–
M 95	12	–
M 100	12	–
M 105	13	–
M 110	14	–
M 120	15	–
M 130	16	–
M 140	17	–
M 150	18	–
M 160	19	–

¹⁾ Applicable for fine threads only

Equivalent bearing loads

When determining the equivalent bearing load for preloaded bearings, the preload must be taken into account. Depending on the operating conditions, the requisite axial component of the bearing load F_a for a bearing pair arranged back-to-back or face-to-face can be approximated using the following equations.

For bearing pairs under radial load and mounted with an interference fit

$$F_a = G_m$$

For bearing pairs under radial load and preloaded by springs

$$F_a = G_{A,B,C}$$

For bearing pairs under axial load and mounted with an interference fit

$$F_a = G_m + 0,67 K_a \quad \text{for } K_a \leq 3 G_m$$

$$F_a = K_a \quad \text{for } K_a > 3 G_m$$

For bearing pairs under axial load and preloaded by springs

$$F_a = G_{A,B,C} + K_a$$

where

F_a = axial component of the load [N]

$G_{A,B,C}$ = built-in preload of the bearing pair, prior to mounting (→ **table 3** on **page 22**) [N]

G_m = preload in the mounted bearing pair (→ *Preload in mounted bearing sets*, **page 22**) [N]

K_a = external axial force acting on a single bearing [N]

Table 11

Calculation factors for load carrying capacities of bearing sets

Number of bearings	Calculation factor for		
	C	C_0	P_u
2	1,62	2	2
3	2,16	3	3
4	2,64	4	4

Equivalent dynamic bearing load

For single bearings and bearings paired in tandem

$$P = F_r \quad \text{for } F_a/F_r \leq e$$

$$P = XF_r + YF_a \quad \text{for } F_a/F_r > e$$

For bearing pairs, arranged back-to-back or face-to-face

$$P = F_r + Y_1 F_a \quad \text{for } F_a/F_r \leq e$$

$$P = XF_r + Y_2 F_a \quad \text{for } F_a/F_r > e$$

where

P = equivalent dynamic load of the bearing set [kN]

F_r = radial component of the load acting on the bearing set [kN]

F_a = axial component of the load acting on the bearing set [kN]

The values for the calculation factors e , X , Y , Y_1 and Y_2 depend on the bearing contact angle and are listed in **tables 12** and **13**.

For bearings with a 15° contact angle, the factors also depend on the relationship $f_0 F_a / C_0$ where f_0 is the calculation factor and C_0 is the basic static load rating, both of which are listed in the product tables.

Equivalent static bearing load

For single bearings and bearings paired in tandem

$$P_0 = 0,5 F_r + Y_0 F_a$$

For bearing pairs, arranged back-to-back or face-to-face

$$P_0 = F_r + Y_0 F_a$$

where

P_0 = equivalent static load of the bearing set [kN]

F_r = radial component of the load acting on the bearing set [kN]

F_a = axial component of the load acting on the bearing set [kN]

If $P_0 < F_r$, $P_0 = F_r$ should be used. The values for the calculation factor Y_0 depend on the bearing contact angle and are listed in **tables 12** and **13**.

Table 12

Calculation factors for single bearings and bearings paired in tandem

$f_0 F_a / C_0$	Calculation factors			
	e	X	Y	Y_0
For 15° contact angle designation suffix CB (1)				
$\leq 0,178$	0,38	0,44	1,47	0,46
0,357	0,4	0,44	1,4	0,46
0,714	0,43	0,44	1,3	0,46
1,07	0,46	0,44	1,23	0,46
1,43	0,47	0,44	1,19	0,46
2,14	0,5	0,44	1,12	0,46
3,57	0,55	0,44	1,02	0,46
$\geq 5,35$	0,56	0,44	1	0,46
For 25° contact angle designation suffix ACB (3)				
–	0,68	0,41	0,87	0,38

Note: Data for bearings with an 18° contact angle is available on request.

Table 13

Calculation factors for bearing pairs arranged back-to-back or face-to-face

$2 f_0 F_a / C_0$	Calculation factors				
	e	X	Y_1	Y_2	Y_0
For 15° contact angle designation suffix CB (1)					
$\leq 0,178$	0,38	0,72	1,65	2,39	0,92
0,357	0,4	0,72	1,57	2,28	0,92
0,714	0,43	0,72	1,46	2,11	0,92
1,07	0,46	0,72	1,38	2	0,92
1,43	0,47	0,72	1,34	1,93	0,92
2,14	0,5	0,72	1,26	1,82	0,92
3,57	0,55	0,72	1,14	1,66	0,92
$\geq 5,35$	0,56	0,72	1,12	1,63	0,92
For 25° contact angle designation suffix ACB (3)					
–	0,68	0,67	0,92	1,41	0,76

Note: Data for bearings with an 18° contact angle is available on request.

Attainable speeds

The attainable speeds listed in the product tables should be regarded as guideline values. They are valid for single bearings under light load ($P \leq 0,05 C$) that are lightly preloaded using springs. In addition, good heat dissipation from the bearing arrangement is a prerequisite.

The values provided for oil lubrication apply to the oil-air lubrication method and should be reduced if other oil lubrication methods are used. The values provided for grease lubrication are maximum values that can be attained with sealed bearings or open bearings with good lubricating grease that has a low consistency and low viscosity.

If single bearings are adjusted against each other with heavier preload or if bearing sets are used, the attainable speeds listed in the product tables should be reduced i.e. the values should be multiplied by a reduction factor. Values for this reduction factor, which depend on the bearing arrangement and preload class, are listed in **table 14**.

If the rotational speed obtained is not sufficient for the application, precision-matched spacer rings in the bearing set can be used to significantly increase the speed capability. SKF sealed bearings in the S719 .. B ($HB \dots /S$) and S70 .. B ($HX \dots /S$) series are designed for high-speed operation i.e. for a speed factor A up to 1 600 000 mm/min.

Cages

SKF bearings in the S719 .. B (*HB.. /S*) and S70 .. B (*HX.. /S*) series have a one-piece outer ring shoulder-guided cage made of fabric reinforced phenolic resin (→ **fig. 3**) that can withstand temperatures up to 120 °C.

Seals

The non-contact seals in SKF S719 .. B (*HB.. /S*) and S70 .. B (*HX.. /S*) series bearings are made of acrylonitrile-butadiene rubber (NBR) and are designed for high-speed operation (speed factor A up to 1 600 000 mm/min). The permissible operating temperature range of the seals is -25 to +100 °C and up to 120 °C for brief periods.

Materials

The rings and balls of SKF all-steel bearings in the S719 .. B (*HB.. /S*) and S70 .. B (*HX.. /S*) series are made from SKF Grade 3 steel, in accordance with ISO 683-17:1999. Balls of hybrid bearings are made of bearing grade silicon nitride Si_3N_4 .

The integral seals are made of an oil- and wear-resistant acrylonitrile-butadiene rubber (NBR) and are reinforced with sheet steel. The O-rings of open bearings that are used for direct oil lubrication are also made of acrylonitrile-butadiene rubber.

Heat treatment

All SKF super-precision bearings undergo a special heat treatment to achieve a good balance between hardness and dimensional stability. The hardness of the rings and rolling elements is optimized for wear-resistance.



Fig. 3

Table 14

Speed reduction factors for bearing sets

Number of bearings	Arrangement	Designation suffix	Speed reduction factor for preload class		
			A	B	C
2	Back-to-back	DB (<i>DD</i>)	0,83	0,78	0,58
	Face-to-face	DF (<i>FF</i>)	0,8	0,74	0,54
3	Back-to-back and tandem	TBT (<i>TD</i>)	0,72	0,66	0,4
	Face-to-face and tandem	TFT (<i>TF</i>)	0,64	0,56	0,3
4	Tandem back-to-back	QBC (<i>TDT</i>)	0,67	0,64	0,48
	Tandem face-to-face	QFC (<i>TFT</i>)	0,64	0,6	0,41

Marking of bearings and bearing sets

Each SKF bearing in the S719 .. B (HB .. /S) and S70 .. B (HX .. /S) series has various identifiers on the external surfaces of the rings (→ **fig. 4**):

- 1 SKF trademark
- 2 Complete designation of the bearing
- 3 Country of manufacture
- 4 Date of manufacture, coded
- 5 Deviation of the mean outside diameter, Δ_{Dm} [μm], and position of the maximum eccentricity of the outer ring
- 6 Deviation of the mean bore diameter, Δ_{dm} [μm], and position of the maximum eccentricity of the inner ring
- 7 Serial number (bearing sets only)
- 8 "V-shaped" marking (matched bearing sets only)

"V-shaped" marking

A "V-shaped" marking on the outside surface of the outer rings of matched bearing sets indicates how the bearings should be mounted to obtain the proper preload in the set. The marking also indicates how the bearing set should be mounted in relation to the axial load. The "V-shaped" marking should point in the direction in which the axial load will act on the inner ring (→ **fig. 5**). In applications where there are axial loads in both directions, the "V-shaped" marking should point toward the greater of the two loads.

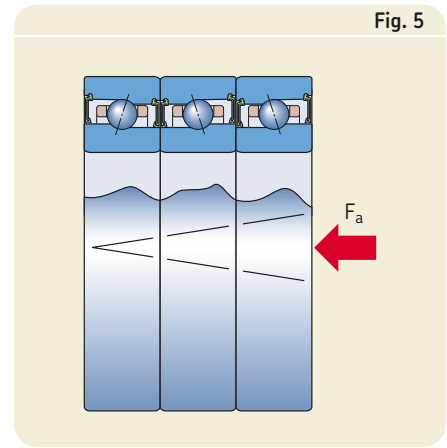

Fig. 5

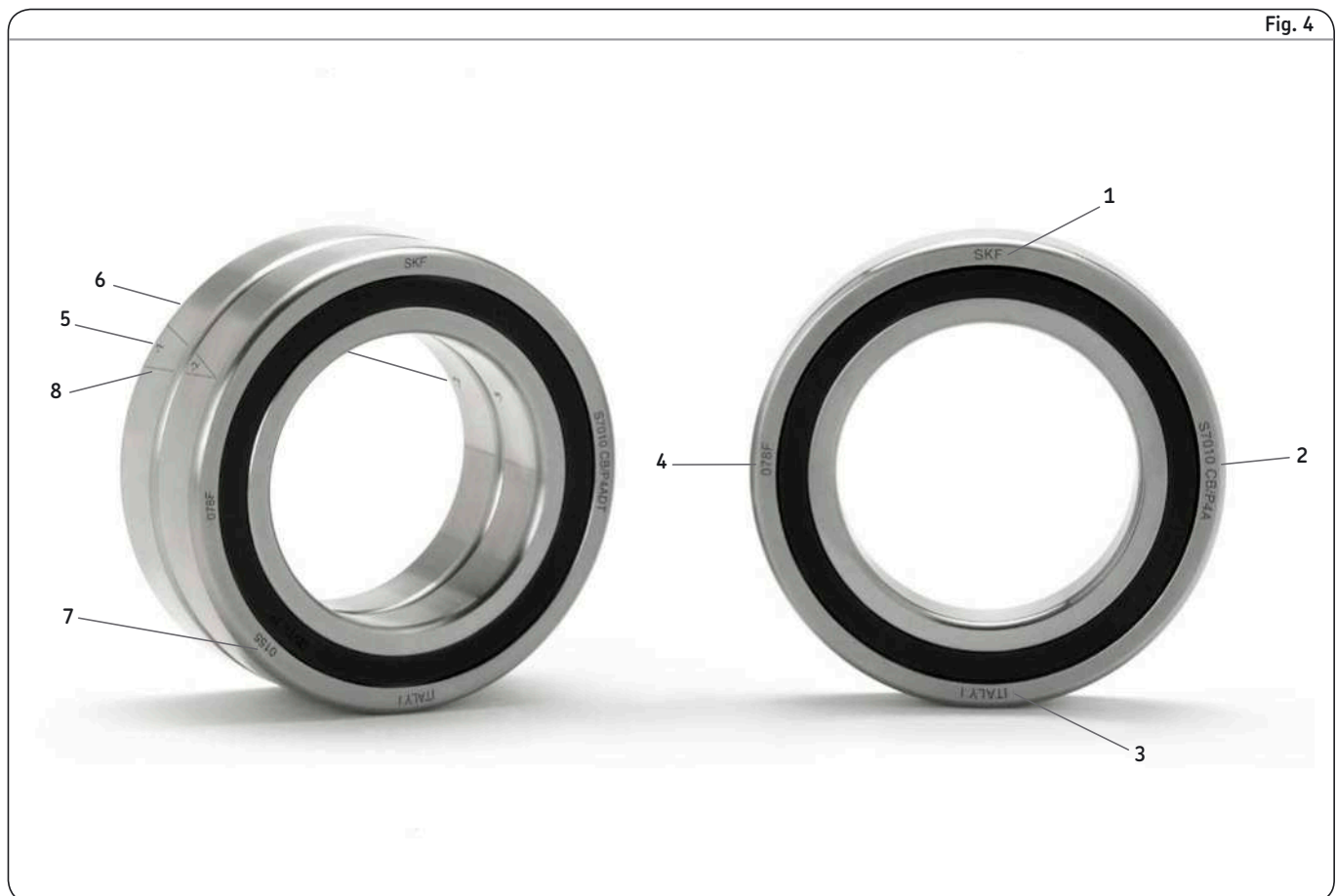

Fig. 4

Packaging

Super-precision bearings are distributed in new SKF illustrated boxes (→ **fig. 6**). An instruction sheet, with information about mounting bearing sets, is supplied in each box.

Designation system

The designations for SKF bearings in the 719 .. B (HB) and 70 .. B (HX) series are provided in **table 15** on **pages 32** and **33** together with their definitions.



Designation system for SKF super-precision angular contact ball bearings in the 719 .. B (HB) and 70 .. B (HX) series

Single bearing: S71912 ACBGA/HCP4A	S	719	12	ACB	GA	/	HC	P4A			
	Variant prefix	Series	Size	Contact angle and design	Execution and preload (single bearing)		Ball material	Tolerance class	Lubrication feature	Arrangement	Preload
Matched bearing set: 7006 CB/PA9ALQBCB		70	06	CB		/		PA9A	L	QBC	B

Variant (prefix)

–	Open bearing (no designation prefix)
S	Sealed bearing
V	Bearing with NitroMax steel rings and bearing grade silicon nitride Si ₃ N ₄ balls ¹⁾

Bearing series

719	In accordance with ISO dimension series 19
70	In accordance with ISO dimension series 10

Bearing size

06	(x5) 30 mm bore diameter
to	
24	(x5) 120 mm bore diameter

Contact angle and internal design

CB	15° contact angle, high-speed B design
FB	18° contact angle, high-speed B design
ACB	25° contact angle, high-speed B design

Single bearing – execution and preload

–	Single bearing (no designation suffix)
GA	Single, universally matchable, for light preload
GB	Single, universally matchable, for moderate preload
GC	Single, universally matchable, for heavy preload

Cage

–	Fabric reinforced phenolic resin, outer ring centred (no designation suffix)
---	--

Ball material

–	Carbon chromium steel (no designation suffix)
HC	Bearing grade silicon nitride Si ₃ N ₄ (hybrid bearings)

Tolerance class

P4A	Dimensional accuracy in accordance with ISO tolerance class 4, running accuracy better than ISO tolerance class 4
PA9A	Dimensional and running accuracy better than ABMA tolerance class ABEC 9

Lubrication feature

L	Annular grooves, lubrication holes and O-rings in the outer ring for direct oil lubrication
---	---

Bearing set – arrangement

DB	Two bearings arranged back-to-back <>
DF	Two bearings arranged face-to-face >>
DT	Two bearings arranged in tandem <<
DG	Two bearings for universal matching
TBT	Three bearings arranged back-to-back and tandem <>>
TFT	Three bearings arranged face-to-face and tandem ><<
TT	Three bearings arranged in tandem <<<
TG	Three bearings for universal matching
QBC	Four bearings arranged tandem back-to-back <<>>
QFC	Four bearings arranged tandem face-to-face >><<
QBT	Four bearings arranged back-to-back and tandem <>>>
QFT	Four bearings arranged face-to-face and tandem ><<<
QT	Four bearings arranged in tandem <<<<
QG	Four bearings for universal matching

Bearing set – preload

A	Light preload
B	Moderate preload
C	Heavy preload
G...	Special preload, expressed in daN e.g. G240

¹⁾ For additional information, contact the SKF application engineering service.

SNFA designation system for super-precision angular contact ball bearings in the 719 .. B (HB) and 70 .. B (HX) series

Single bearing: HB60 /S/NS 7CE3 UL	HB	60	/S	/NS	7	CE	3	U	L
	Series and design	Size	Variant	Ball material	Tolerance class	Cage	Contact angle	Arrangement	Preload
Matched bearing set: HX30 /GH 9CE1 TDTM	HX	30	/GH		9	CE	1	TDT	M

Variant

- Open bearing (no designation suffix)
- /S Sealed bearing
- /XN Bearing with NitroMax steel rings and bearing grade silicon nitride Si₃N₄ balls¹⁾

Bearing series and internal design

- HB In accordance with ISO dimension series 19, high-speed HB design
- HX In accordance with ISO dimension series 10, high-speed HX design

Bearing size

- 30 30 mm bore diameter
- to 120 120 mm bore diameter

Contact angle

- 1 15° contact angle
- 2 18° contact angle
- 3 25° contact angle

Single bearing – execution and preload

- Single bearing (no designation suffix)
- UL Single, universally matchable, for light preload
- UM Single, universally matchable, for moderate preload
- UF Single, universally matchable, for heavy preload

Cage

- CE Fabric reinforced phenolic resin, outer ring centred

Ball material

- Carbon chromium steel (no designation suffix)
- /NS Bearing grade silicon nitride Si₃N₄ (hybrid bearings)

Tolerance class

- 7 Dimensional and running accuracy in accordance with ABMA tolerance class ABEC 7
- 9 Dimensional and running accuracy in accordance with ABMA tolerance class ABEC 9

Additional open bearing variant

- /GH Annular grooves, lubrication holes and O-rings in the outer ring for direct oil lubrication

Bearing set – arrangement

- DD Two bearings arranged back-to-back <>
- FF Two bearings arranged face-to-face >>
- T Two bearings arranged in tandem <<
- DU Two bearings for universal matching
- TD Three bearings arranged back-to-back and tandem <>>
- TF Three bearings arranged face-to-face and tandem >><
- 3T Three bearings arranged in tandem <<<
- TU Three bearings for universal matching
- TDT Four bearings arranged tandem back-to-back <<>>
- TFT Four bearings arranged tandem face-to-face >><<
- 3TD Four bearings arranged back-to-back and tandem <>>>
- 3TF Four bearings arranged face-to-face and tandem >><<
- 4T Four bearings arranged in tandem <<<<
- 4U Four bearings for universal matching

Bearing set – preload

- L Light preload (for symmetrical sets only)
- M Moderate preload (for symmetrical sets only)
- F Heavy preload (for symmetrical sets only)
- ..daN Special preload (for asymmetrical sets TD, TF, 3TD, 3TF and for special preload executions)¹⁾



Super-precision angular contact ball bearings
d 30 – 50 mm

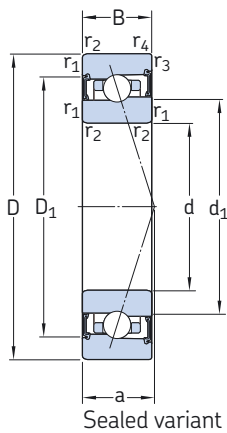

Sealed variant



Open variant

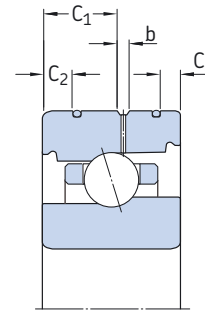

Open variant for direct oil lubrication

Principal dimensions			Basic load ratings		Fatigue load limit	Calculation factor	Attainable speed		Mass ³⁾	Designations of sealed bearings ⁴⁾	
d	D	B	dynamic ¹⁾	static			P _u	f ₀		when lubricating with grease	oil-air ²⁾
mm			kN		kN	–	r/min	kg	–		
30	47	9	4,88	3,15	0,134	9,5	40 000	60 000	0,050	S71906 CB/P4A	HB30 /S 7CE1
	47	9	4,88	3,15	0,134	9,5	48 000	75 000	0,047	S71906 CB/HCP4A	HB30 /S/NS 7CE1
	47	9	4,62	3	0,127	–	36 000	56 000	0,050	S71906 ACB/P4A	HB30 /S 7CE3
	47	9	4,62	3	0,127	–	43 000	67 000	0,047	S71906 ACB/HCP4A	HB30 /S/NS 7CE3
	55	13	6,5	4,15	0,176	9,4	36 000	56 000	0,13	S7006 CB/P4A	HX30 /S 7CE1
	55	13	6,5	4,15	0,176	9,4	43 000	67 000	0,13	S7006 CB/HCP4A	HX30 /S/NS 7CE1
	55	13	6,18	3,9	0,166	–	34 000	50 000	0,13	S7006 ACB/P4A	HX30 /S 7CE3
	55	13	6,18	3,9	0,166	–	40 000	60 000	0,13	S7006 ACB/HCP4A	HX30 /S/NS 7CE3
35	55	10	5,2	3,65	0,156	9,7	34 000	53 000	0,081	S71907 CB/P4A	HB35 /S 7CE1
	55	10	5,2	3,65	0,156	9,7	40 000	63 000	0,077	S71907 CB/HCP4A	HB35 /S/NS 7CE1
	55	10	4,88	3,45	0,146	–	30 000	48 000	0,081	S71907 ACB/P4A	HB35 /S 7CE3
	55	10	4,88	3,45	0,146	–	36 000	56 000	0,077	S71907 ACB/HCP4A	HB35 /S/NS 7CE3
	62	14	6,89	4,8	0,204	9,6	32 000	48 000	0,17	S7007 CB/P4A	HX35 /S 7CE1
	62	14	6,89	4,8	0,204	9,6	38 000	60 000	0,16	S7007 CB/HCP4A	HX35 /S/NS 7CE1
	62	14	6,5	4,55	0,193	–	28 000	43 000	0,17	S7007 ACB/P4A	HX35 /S 7CE3
	62	14	6,5	4,55	0,193	–	34 000	53 000	0,16	S7007 ACB/HCP4A	HX35 /S/NS 7CE3
40	62	12	5,4	4,15	0,176	9,8	30 000	45 000	0,12	S71908 CB/P4A	HB40 /S 7CE1
	62	12	5,4	4,15	0,176	9,8	36 000	56 000	0,12	S71908 CB/HCP4A	HB40 /S/NS 7CE1
	62	12	5,07	4	0,166	–	28 000	43 000	0,12	S71908 ACB/P4A	HB40 /S 7CE3
	62	12	5,07	4	0,166	–	32 000	50 000	0,12	S71908 ACB/HCP4A	HB40 /S/NS 7CE3
	68	15	7,41	5,6	0,236	9,8	28 000	43 000	0,21	S7008 CB/P4A	HX40 /S 7CE1
	68	15	7,41	5,6	0,236	9,8	34 000	53 000	0,20	S7008 CB/HCP4A	HX40 /S/NS 7CE1
	68	15	6,89	5,3	0,224	–	26 000	40 000	0,21	S7008 ACB/P4A	HX40 /S 7CE3
	68	15	6,89	5,3	0,224	–	32 000	48 000	0,20	S7008 ACB/HCP4A	HX40 /S/NS 7CE3
45	68	12	7,41	5,7	0,245	9,7	28 000	43 000	0,14	S71909 CB/P4A	HB45 /S 7CE1
	68	12	7,41	5,7	0,245	9,7	32 000	50 000	0,13	S71909 CB/HCP4A	HB45 /S/NS 7CE1
	68	12	7,02	5,4	0,232	–	24 000	38 000	0,14	S71909 ACB/P4A	HB45 /S 7CE3
	68	12	7,02	5,4	0,232	–	30 000	45 000	0,13	S71909 ACB/HCP4A	HB45 /S/NS 7CE3
	75	16	9,56	7,2	0,305	9,6	26 000	40 000	0,26	S7009 CB/P4A	HX45 /S 7CE1
	75	16	9,56	7,2	0,305	9,6	30 000	48 000	0,25	S7009 CB/HCP4A	HX45 /S/NS 7CE1
	75	16	9,04	6,8	0,285	–	24 000	36 000	0,26	S7009 ACB/P4A	HX45 /S 7CE3
	75	16	9,04	6,8	0,285	–	28 000	43 000	0,25	S7009 ACB/HCP4A	HX45 /S/NS 7CE3
50	72	12	7,61	6,2	0,265	9,8	26 000	38 000	0,14	S71910 CB/P4A	HB50 /S 7CE1
	72	12	7,61	6,2	0,265	9,8	30 000	45 000	0,13	S71910 CB/HCP4A	HB50 /S/NS 7CE1
	72	12	7,28	5,85	0,25	–	22 000	36 000	0,14	S71910 ACB/P4A	HB50 /S 7CE3
	72	12	7,28	5,85	0,25	–	28 000	43 000	0,13	S71910 ACB/HCP4A	HB50 /S/NS 7CE3
	80	16	9,95	7,8	0,335	9,7	24 000	36 000	0,29	S7010 CB/P4A	HX50 /S 7CE1
	80	16	9,95	7,8	0,335	9,7	28 000	45 000	0,28	S7010 CB/HCP4A	HX50 /S/NS 7CE1
	80	16	9,36	7,35	0,31	–	22 000	32 000	0,29	S7010 ACB/P4A	HX50 /S 7CE3
	80	16	9,36	7,35	0,31	–	26 000	40 000	0,28	S7010 ACB/HCP4A	HX50 /S/NS 7CE3

¹⁾ The basic dynamic load ratings listed in the product tables are calculated in accordance with ISO 281:2007 and cannot be compared with ratings calculated by other calculation methods.

²⁾ Applicable to open bearings only

³⁾ Applicable to sealed bearings only

⁴⁾ For designations of open bearings and other variants, refer to **table 15** on **pages 32** and **33**.

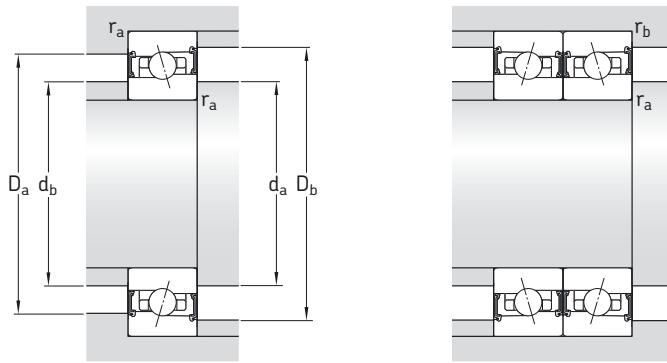

Dimensions

Abutment and fillet dimensions

d	d ₁ ~	D ₁ ~	r _{1,2} min	r _{3,4} min	a	C ₃	C ₂	C ₁	b	d _a , d _b min	D _a max	D _b max	r _a max	r _b max
mm										mm				
30	36	43	0,3	0,15	12	-	-	-	-	32	45	45	0,3	0,15
	36	43	0,3	0,15	12	-	-	-	-	32	45	45	0,3	0,15
	36	43	0,3	0,15	16	-	-	-	-	32	45	45	0,3	0,15
	36	43	0,3	0,15	16	-	-	-	-	32	45	45	0,3	0,15
	39,5	47,2	1	0,6	12	-	-	-	-	34,6	50,4	50,4	1	0,6
	39,5	47,2	1	0,6	12	-	-	-	-	34,6	50,4	50,4	1	0,6
	39,5	47,2	1	0,6	16	-	-	-	-	34,6	50,4	50,4	1	0,6
	39,5	47,2	1	0,6	16	-	-	-	-	34,6	50,4	50,4	1	0,6
35	42,5	49,5	0,6	0,3	14	-	-	-	-	38,2	51,8	51,8	0,6	0,3
	42,5	49,5	0,6	0,3	14	-	-	-	-	38,2	51,8	51,8	0,6	0,3
	42,5	49,5	0,6	0,3	18	-	-	-	-	38,2	51,8	51,8	0,6	0,3
	42,5	49,5	0,6	0,3	18	-	-	-	-	38,2	51,8	51,8	0,6	0,3
	45,5	53,3	1	0,6	14	-	-	-	-	39,6	57,4	57,4	1	0,6
	45,5	53,3	1	0,6	14	-	-	-	-	39,6	57,4	57,4	1	0,6
	45,5	53,3	1	0,6	18	-	-	-	-	39,6	57,4	57,4	1	0,6
	45,5	53,3	1	0,6	18	-	-	-	-	39,6	57,4	57,4	1	0,6
40	48,5	55,6	0,6	0,3	15	2,8	1,7	5,9	2	43,2	58,8	58,8	0,6	0,3
	48,5	55,6	0,6	0,3	15	2,8	1,7	5,9	2	43,2	58,8	58,8	0,6	0,3
	48,5	55,6	0,6	0,3	20	2,8	1,7	5,9	2	43,2	58,8	58,8	0,6	0,3
	48,5	55,6	0,6	0,3	20	2,8	1,7	5,9	2	43,2	58,8	58,8	0,6	0,3
	51	58,8	1	0,6	15	3,6	2,6	7,8	1,5	44,6	63,4	63,4	1	0,6
	51	58,8	1	0,6	15	3,6	2,6	7,8	1,5	44,6	63,4	63,4	1	0,6
	51	58,8	1	0,6	20	3,6	2,6	7,8	1,5	44,6	63,4	63,4	1	0,6
	51	58,8	1	0,6	20	3,6	2,6	7,8	1,5	44,6	63,4	63,4	1	0,6
45	53,5	61,8	0,6	0,3	16	2,8	1,7	5,9	2	48,2	64,8	64,8	0,6	0,3
	53,5	61,8	0,6	0,3	16	2,8	1,7	5,9	2	48,2	64,8	64,8	0,6	0,3
	53,5	61,8	0,6	0,3	22	2,8	1,7	5,9	2	48,2	64,8	64,8	0,6	0,3
	53,5	61,8	0,6	0,3	22	2,8	1,7	5,9	2	48,2	64,8	64,8	0,6	0,3
	56,5	65,5	1	0,6	16	3,6	2,6	8,6	1,5	49,6	70,4	70,4	1	0,6
	56,5	65,5	1	0,6	16	3,6	2,6	8,6	1,5	49,6	70,4	70,4	1	0,6
	56,5	65,5	1	0,6	22	3,6	2,6	8,6	1,5	49,6	70,4	70,4	1	0,6
	56,5	65,5	1	0,6	22	3,6	2,6	8,6	1,5	49,6	70,4	70,4	1	0,6
50	58	66	0,6	0,3	17	2,8	1,7	5,9	5,9	53,2	68,8	68,8	0,6	0,3
	58	66	0,6	0,3	17	2,8	1,7	5,9	5,9	53,2	68,8	68,8	0,6	0,3
	58	66	0,6	0,3	23	2,8	1,7	5,9	5,9	53,2	68,8	68,8	0,6	0,3
	58	66	0,6	0,3	23	2,8	1,7	5,9	5,9	53,2	68,8	68,8	0,6	0,3
	61,5	70,7	1	0,6	17	2,6	2,6	8,6	1,5	54,6	75,4	75,4	1	0,6
	61,5	70,7	1	0,6	17	2,6	2,6	8,6	1,5	54,6	75,4	75,4	1	0,6
	61,5	70,7	1	0,6	23	2,6	2,6	8,6	1,5	54,6	75,4	75,4	1	0,6
	61,5	70,7	1	0,6	23	2,6	2,6	8,6	1,5	54,6	75,4	75,4	1	0,6



Super-precision angular contact ball bearings
d 55 – 75 mm

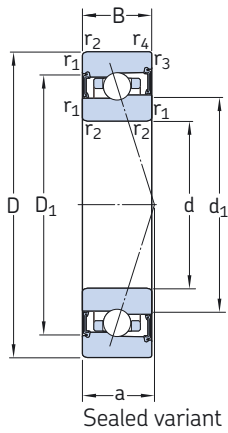

Sealed variant



Open variant

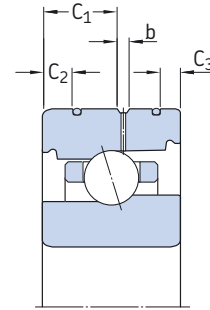

Open variant for direct oil lubrication

Principal dimensions			Basic load ratings		Fatigue load limit	Calculation factor	Attainable speed		Mass ³⁾	Designations of sealed bearings ⁴⁾	
d	D	B	dynamic ¹⁾	static			P _u	f ₀		when lubricating with grease	oil-air ²⁾
mm			kN		kN	–	r/min	kg	–		
55	80	13	9,95	8,15	0,345	9,8	22 000	34 000	0,19	S71911 CB/P4A	HB55 /S 7CE1
	80	13	9,95	8,15	0,345	9,8	28 000	43 000	0,18	S71911 CB/HCP4A	HB55 /S/NS 7CE1
	80	13	9,36	7,65	0,325	–	20 000	32 000	0,19	S71911 ACB/P4A	HB55 /S 7CE3
	80	13	9,36	7,65	0,325	–	24 000	38 000	0,18	S71911 ACB/HCP4A	HB55 /S/NS 7CE3
	90	18	14	11	0,465	9,7	22 000	32 000	0,42	S7011 CB/P4A	HX55 /S 7CE1
	90	18	14	11	0,465	9,7	26 000	40 000	0,40	S7011 CB/HCP4A	HX55 /S/NS 7CE1
	90	18	13,3	10,4	0,44	–	19 000	30 000	0,42	S7011 ACB/P4A	HX55 /S 7CE3
	90	18	13,3	10,4	0,44	–	24 000	36 000	0,40	S7011 ACB/HCP4A	HX55 /S/NS 7CE3
60	85	13	10,4	8,8	0,375	9,8	22 000	32 000	0,20	S71912 CB/P4A	HB60 /S 7CE1
	85	13	10,4	8,8	0,375	9,8	26 000	40 000	0,19	S71912 CB/HCP4A	HB60 /S/NS 7CE1
	85	13	9,75	8,3	0,355	–	19 000	30 000	0,20	S71912 ACB/P4A	HB60 /S 7CE3
	85	13	9,75	8,3	0,355	–	22 000	36 000	0,19	S71912 ACB/HCP4A	HB60 /S/NS 7CE3
	95	18	14,6	12	0,51	9,7	19 000	30 000	0,45	S7012 CB/P4A	HX60 /S 7CE1
	95	18	14,6	12	0,51	9,7	24 000	36 000	0,43	S7012 CB/HCP4A	HX60 /S/NS 7CE1
	95	18	13,5	11,4	0,48	–	17 000	26 000	0,45	S7012 ACB/P4A	HX60 /S 7CE3
	95	18	13,5	11,4	0,48	–	22 000	32 000	0,43	S7012 ACB/HCP4A	HX60 /S/NS 7CE3
65	90	13	10,6	9,5	0,4	9,9	20 000	30 000	0,22	S71913 CB/P4A	HB65 /S 7CE1
	90	13	10,6	9,5	0,4	9,9	24 000	36 000	0,20	S71913 CB/HCP4A	HB65 /S/NS 7CE1
	90	13	9,95	9	0,38	–	18 000	28 000	0,22	S71913 ACB/P4A	HB65 /S 7CE3
	90	13	9,95	9	0,38	–	22 000	34 000	0,20	S71913 ACB/HCP4A	HB65 /S/NS 7CE3
	100	18	15,6	12,9	0,55	9,7	18 000	28 000	0,47	S7013 CB/P4A	HX65 /S 7CE1
	100	18	15,6	12,9	0,55	9,7	22 000	34 000	0,45	S7013 CB/HCP4A	HX65 /S/NS 7CE1
	100	18	14,6	12,2	0,52	–	16 000	26 000	0,47	S7013 ACB/P4A	HX65 /S 7CE3
	100	18	14,6	12,2	0,52	–	19 000	30 000	0,45	S7013 ACB/HCP4A	HX65 /S/NS 7CE3
70	100	16	13,5	12,2	0,52	9,9	18 000	28 000	0,36	S71914 CB/P4A	HB70 /S 7CE1
	100	16	13,5	12,2	0,52	9,9	22 000	32 000	0,34	S71914 CB/HCP4A	HB70 /S/NS 7CE1
	100	16	12,7	11,6	0,49	–	16 000	24 000	0,36	S71914 ACB/P4A	HB70 /S 7CE3
	100	16	12,7	11,6	0,49	–	19 000	30 000	0,34	S71914 ACB/HCP4A	HB70 /S/NS 7CE3
	110	20	19	16,3	0,695	9,6	17 000	26 000	0,47	S7014 CB/P4A	HX70 /S 7CE1
	110	20	19	16,3	0,695	9,6	20 000	30 000	0,63	S7014 CB/HCP4A	HX70 /S/NS 7CE1
	110	20	18,2	15,6	0,655	–	15 000	24 000	0,47	S7014 ACB/P4A	HX70 /S 7CE3
	110	20	18,2	15,6	0,655	–	18 000	28 000	0,63	S7014 ACB/HCP4A	HX70 /S/NS 7CE3
75	105	16	14	13,2	0,56	9,9	17 000	26 000	0,38	S71915 CB/P4A	HB75 /S 7CE1
	105	16	14	13,2	0,56	9,9	20 000	30 000	0,36	S71915 CB/HCP4A	HB75 /S/NS 7CE1
	105	16	13,3	12,5	0,52	–	15 000	24 000	0,38	S71915 ACB/P4A	HB75 /S 7CE3
	105	16	13,3	12,5	0,52	–	18 000	28 000	0,36	S71915 ACB/HCP4A	HB75 /S/NS 7CE3
	115	20	19,9	17,6	0,75	9,7	16 000	24 000	0,70	S7015 CB/P4A	HX75 /S 7CE1
	115	20	19,9	17,6	0,75	9,7	18 000	28 000	0,66	S7015 CB/HCP4A	HX75 /S/NS 7CE1
	115	20	19	16,6	0,71	–	14 000	22 000	0,70	S7015 ACB/P4A	HX75 /S 7CE3
	115	20	19	16,6	0,71	–	17 000	26 000	0,66	S7015 ACB/HCP4A	HX75 /S/NS 7CE3

¹⁾ The basic dynamic load ratings listed in the product tables are calculated in accordance with ISO 281:2007 and cannot be compared with ratings calculated by other calculation methods.

²⁾ Applicable to open bearings only

³⁾ Applicable to sealed bearings only

⁴⁾ For designations of open bearings and other variants, refer to **table 15** on **pages 32** and **33**.

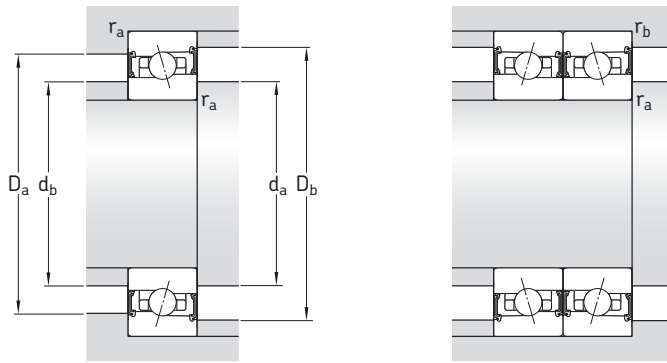

Dimensions

Abutment and fillet dimensions

d	d ₁ ~	D ₁ ~	r _{1,2} min	r _{3,4} min	a	C ₃	C ₂	C ₁	b	d _a , d _b min	D _a max	D _b max	r _a max	r _b max
mm										mm				
55	64	73,2	1	0,3	19	3,8	1,7	6,5	2	59,6	75,4	75,4	1	0,3
	64	73,2	1	0,3	19	3,8	1,7	6,5	2	59,6	75,4	75,4	1	0,3
	64	73,2	1	0,3	26	3,8	1,7	6,5	2	59,6	75,4	75,4	1	0,3
	64	73,2	1	0,3	26	3,8	1,7	6,5	2	59,6	75,4	75,4	1	0,3
	68,2	79,3	1,1	0,6	19	4,3	2,8	9	2,2	61	84	84	1	0,6
	68,2	79,3	1,1	0,6	19	4,3	2,8	9	2,2	61	84	84	1	0,6
	68,2	79,3	1,1	0,6	26	4,3	2,8	9	2,2	61	84	84	1	0,6
	68,2	79,3	1,1	0,6	26	4,3	2,8	9	2,2	61	84	84	1	0,6
60	69	78,3	1	0,3	19	3,8	1,7	6,5	2	64,6	80,4	80,4	1	0,3
	69	78,3	1	0,3	19	3,8	1,7	6,5	2	64,6	80,4	80,4	1	0,3
	69	78,3	1	0,3	27	3,8	1,7	6,5	2	64,6	80,4	80,4	1	0,3
	69	78,3	1	0,3	27	3,8	1,7	6,5	2	64,6	80,4	80,4	1	0,3
	73,2	84,3	1,1	0,6	19	4,3	2,8	9	2,2	66	89	89	1	0,6
	73,2	84,3	1,1	0,6	19	4,3	2,8	9	2,2	66	89	89	1	0,6
	73,2	84,3	1,1	0,6	27	4,3	2,8	9	2,2	66	89	89	1	0,6
	73,2	84,3	1,1	0,6	27	4,3	2,8	9	2,2	66	89	89	1	0,6
65	74	83,4	1	0,3	20	3,8	1,7	6,5	2	69,6	85,4	85,4	1	0,3
	74	83,4	1	0,3	20	3,8	1,7	6,5	2	69,6	85,4	85,4	1	0,3
	74	83,4	1	0,3	28	3,8	1,7	6,5	2	69,6	85,4	85,4	1	0,3
	74	83,4	1	0,3	28	3,8	1,7	6,5	2	69,6	85,4	85,4	1	0,3
	78	89,6	1,1	0,6	20	4,3	2,8	9,7	1,5	71	94	94	1	0,6
	78	89,6	1,1	0,6	20	4,3	2,8	9,7	1,5	71	94	94	1	0,6
	78	89,6	1,1	0,6	28	4,3	2,8	9,7	1,5	71	94	94	1	0,6
	78	89,6	1,1	0,6	28	4,3	2,8	9,7	1,5	71	94	94	1	0,6
70	81	91,6	1	0,3	22	3,8	1,7	8,6	1,5	74,6	95,4	95,4	1	0,3
	81	91,6	1	0,3	22	3,8	1,7	8,6	1,5	74,6	95,4	95,4	1	0,3
	81	91,6	1	0,3	31	3,8	1,7	8,6	1,5	74,6	95,4	95,4	1	0,3
	81	91,6	1	0,3	31	3,8	1,7	8,6	1,5	74,6	95,4	95,4	1	0,3
	85	97,8	1,1	0,6	22	4,4	2,9	10,9	1,5	76	104	104	1	0,6
	85	97,8	1,1	0,6	22	4,4	2,9	10,9	1,5	76	104	104	1	0,6
	85	97,8	1,1	0,6	31	4,4	2,9	10,9	1,5	76	104	104	1	0,6
	85	97,8	1,1	0,6	31	4,4	2,9	10,9	1,5	76	104	104	1	0,6
75	86	97,5	1	0,6	22	3,8	2,7	8,6	1,5	79,6	100	100	1	0,3
	86	97,5	1	0,6	22	3,8	2,7	8,6	1,5	79,6	100	100	1	0,3
	86	97,5	1	0,6	32	3,8	2,7	8,6	1,5	79,6	100	100	1	0,3
	86	97,5	1	0,6	32	3,8	2,7	8,6	1,5	79,6	100	100	1	0,3
	90	102,8	1,1	0,6	22	4,4	2,9	10,9	1,5	81	109	109	1	0,6
	90	102,8	1,1	0,6	22	4,4	2,9	10,9	1,5	81	109	109	1	0,6
	90	102,8	1,1	0,6	32	4,4	2,9	10,9	1,5	81	109	109	1	0,6
	90	102,8	1,1	0,6	32	4,4	2,9	10,9	1,5	81	109	109	1	0,6
	90	102,8	1,1	0,6	32	4,4	2,9	10,9	1,5	81	109	109	1	0,6



Super-precision angular contact ball bearings
d 80 – 100 mm

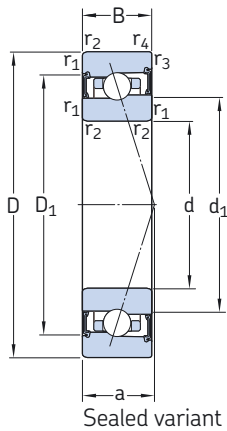

Sealed variant



Open variant

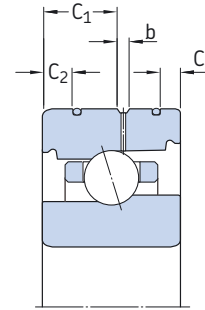

Open variant for direct oil lubrication

Principal dimensions			Basic load ratings dynamic ¹⁾ static		Fatigue load limit	Calculation factor	Attainable speed when lubricating with grease oil-air ²⁾		Mass ³⁾	Designations of sealed bearings ⁴⁾ SKF SNFA	
d	D	B	C	C ₀	P _u	f ₀					
mm			kN		kN	–	r/min		kg	–	
80	110	16	15,6	14,6	0,63	9,9	16 000	24 000	0,40	S71916 CB/P4A	HB80 /S 7CE1
	110	16	15,6	14,6	0,63	9,9	19 000	30 000	0,37	S71916 CB/HCP4A	HB80 /S/NS 7CE1
	110	16	14,8	14	0,585	–	14 000	22 000	0,40	S71916 ACB/P4A	HB80 /S 7CE3
	110	16	14,8	14	0,585	–	17 000	26 000	0,37	S71916 ACB/HCP4A	HB80 /S/NS 7CE3
	125	22	26,5	22,8	0,95	9,6	14 000	20 000	0,92	S7016 CB/P4A	HX80 /S 7CE1
	125	22	26,5	22,8	0,95	9,6	17 000	26 000	0,86	S7016 CB/HCP4A	HX80 /S/NS 7CE1
	125	22	25,1	21,6	0,9	–	12 000	19 000	0,92	S7016 ACB/P4A	HX80 /S 7CE3
	125	22	25,1	21,6	0,9	–	15 000	22 000	0,86	S7016 ACB/HCP4A	HX80 /S/NS 7CE3
85	120	18	16,3	16,3	0,68	10	15 000	22 000	0,59	S71917 CB/P4A	HB85 /S 7CE1
	120	18	16,3	16,3	0,68	10	18 000	28 000	0,56	S71917 CB/HCP4A	HB85 /S/NS 7CE1
	120	18	15,3	15,3	0,64	–	13 000	20 000	0,59	S71917 ACB/P4A	HB85 /S 7CE3
	120	18	15,3	15,3	0,64	–	16 000	24 000	0,56	S71917 ACB/HCP4A	HB85 /S/NS 7CE3
	130	22	27	23,6	0,965	9,6	13 000	20 000	0,96	S7017 CB/P4A	HX85 /S 7CE1
	130	22	27	23,6	0,965	9,6	16 000	24 000	0,90	S7017 CB/HCP4A	HX85 /S/NS 7CE1
	130	22	25,1	22,4	0,915	–	12 000	18 000	0,96	S7017 ACB/P4A	HX85 /S 7CE3
	130	22	25,1	22,4	0,915	–	14 000	22 000	0,90	S7017 ACB/HCP4A	HX85 /S/NS 7CE3
90	125	18	17,8	17,6	0,72	10	14 000	22 000	0,61	S71918 CB/P4A	HB90 /S 7CE1
	125	18	17,8	17,6	0,72	10	16 000	26 000	0,58	S71918 CB/HCP4A	HB90 /S/NS 7CE1
	125	18	16,8	16,6	0,68	–	12 000	19 000	0,61	S71918 ACB/P4A	HB90 /S 7CE3
	125	18	16,8	16,6	0,68	–	15 000	22 000	0,58	S71918 ACB/HCP4A	HB90 /S/NS 7CE3
	140	24	29,1	25	0,98	9,7	12 000	19 000	1,25	S7018 CB/P4A	HX90 /S 7CE1
	140	24	29,1	25	0,98	9,7	15 000	24 000	1,20	S7018 CB/HCP4A	HX90 /S/NS 7CE1
	140	24	27	23,6	0,93	–	11 000	17 000	1,25	S7018 ACB/P4A	HX90 /S 7CE3
	140	24	27	23,6	0,93	–	13 000	20 000	1,20	S7018 ACB/HCP4A	HX90 /S/NS 7CE3
95	130	18	18,2	18,6	0,75	10	13 000	20 000	0,64	S71919 CB/P4A	HB95 /S 7CE1
	130	18	18,2	18,6	0,75	10	16 000	24 000	0,61	S71919 CB/HCP4A	HB95 /S/NS 7CE1
	130	18	17,2	17,6	0,71	–	12 000	18 000	0,64	S71919 ACB/P4A	HB95 /S 7CE3
	130	18	17,2	17,6	0,71	–	14 000	22 000	0,61	S71919 ACB/HCP4A	HB95 /S/NS 7CE3
	145	24	29,6	26	1	9,7	12 000	18 000	1,30	S7019 CB/P4A	HX95 /S 7CE1
	145	24	29,6	26	1	9,7	14 000	22 000	1,20	S7019 CB/HCP4A	HX95 /S/NS 7CE1
	145	24	27,6	24,5	0,95	–	11 000	16 000	1,30	S7019 ACB/P4A	HX95 /S 7CE3
	145	24	27,6	24,5	0,95	–	13 000	19 000	1,20	S7019 ACB/HCP4A	HX95 /S/NS 7CE3
100	140	20	21,6	22,4	0,865	10	12 000	19 000	0,88	S71920 CB/P4A	HB100 /S 7CE1
	140	20	21,6	22,4	0,865	10	15 000	24 000	0,83	S71920 CB/HCP4A	HB100 /S/NS 7CE1
	140	20	20,8	21,2	0,815	–	11 000	17 000	0,88	S71920 ACB/P4A	HB100 /S 7CE3
	140	20	20,8	21,2	0,815	–	13 000	20 000	0,83	S71920 ACB/HCP4A	HB100 /S/NS 7CE3
	150	24	29,6	27	1,02	9,8	11 000	17 000	1,40	S7020 CB/P4A	HX100 /S 7CE1
	150	24	29,6	27	1,02	9,8	13 000	20 000	1,30	S7020 CB/HCP4A	HX100 /S/NS 7CE1
	150	24	28,1	25,5	0,98	–	10 000	15 000	1,40	S7020 ACB/P4A	HX100 /S 7CE3
	150	24	28,1	25,5	0,98	–	12 000	18 000	1,30	S7020 ACB/HCP4A	HX100 /S/NS 7CE3

¹⁾ The basic dynamic load ratings listed in the product tables are calculated in accordance with ISO 281:2007 and cannot be compared with ratings calculated by other calculation methods.

²⁾ Applicable to open bearings only

³⁾ Applicable to sealed bearings only

⁴⁾ For designations of open bearings and other variants, refer to **table 15** on **pages 32** and **33**.

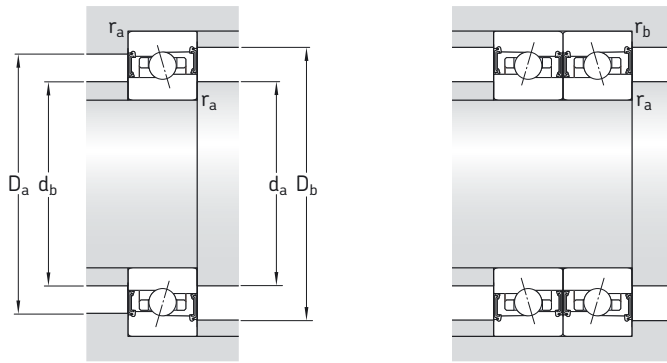

C

Dimensions

Abutment and fillet dimensions

d	d ₁ ~	D ₁ ~	r _{1,2} min	r _{3,4} min	a	C ₃	C ₂	C ₁	b	d _{a,d_b} min	D _a max	D _b max	r _a max	r _b max
mm										mm				
80	90,7	102,2	1	0,6	25	3,8	2,7	8,6	2	84,6	105	105	1	0,3
	90,7	102,2	1	0,6	25	3,8	2,7	8,6	2	84,6	105	105	1	0,3
	90,7	102,2	1	0,6	35	3,8	2,7	8,6	2	84,6	105	105	1	0,3
	90,7	102,2	1	0,6	35	3,8	2,7	8,6	2	84,6	105	105	1	0,3
	96,7	111,4	1,1	0,6	25	4,7	3,2	11,1	2,5	86	119	119	1	0,6
	96,7	111,4	1,1	0,6	25	4,7	3,2	11,1	2,5	86	119	119	1	0,6
	96,7	111,4	1,1	0,6	35	4,7	3,2	11,1	2,5	86	119	119	1	0,6
	96,7	111,4	1,1	0,6	35	4,7	3,2	11,1	2,5	86	119	119	1	0,6
85	98,2	110,2	1,1	0,6	26	4,5	2,9	9,3	2,2	91	114	114	1	0,6
	98,2	110,2	1,1	0,6	26	4,5	2,9	9,3	2,2	91	114	114	1	0,6
	98,2	110,2	1,1	0,6	36	4,5	2,9	9,3	2,2	91	114	114	1	0,6
	98,2	110,2	1,1	0,6	36	4,5	2,9	9,3	2,2	91	114	114	1	0,6
	101,7	116,4	1,1	0,6	26	4,7	3,2	11,1	2,5	91	124	124	1	0,6
	101,7	116,4	1,1	0,6	26	4,7	3,2	11,1	2,5	91	124	124	1	0,6
	101,7	116,4	1,1	0,6	36	4,7	3,2	11,1	2,5	91	124	124	1	0,6
	101,7	116,4	1,1	0,6	36	4,7	3,2	11,1	2,5	91	124	124	1	0,6
90	103	115	1,1	0,6	28	4,5	2,9	9,3	2,2	96	119	119	1	0,6
	103	115	1,1	0,6	28	4,5	2,9	9,3	2,2	96	119	119	1	0,6
	103	115	1,1	0,6	39	4,5	2,9	9,3	2,2	96	119	119	1	0,6
	103	115	1,1	0,6	39	4,5	2,9	9,3	2,2	96	119	119	1	0,6
	108,7	125	1,5	1	28	5,2	4,2	13,4	2,2	97	133	133	1,5	1
	108,7	125	1,5	1	28	5,2	4,2	13,4	2,2	97	133	133	1,5	1
	108,7	125	1,5	1	39	5,2	4,2	13,4	2,2	97	133	133	1,5	1
	108,7	125	1,5	1	39	5,2	4,2	13,4	2,2	97	133	133	1,5	1
95	108	120,7	1,1	0,6	28	4,5	2,9	9,3	2,2	101	124	124	1	0,6
	108	120,7	1,1	0,6	28	4,5	2,9	9,3	2,2	101	124	124	1	0,6
	108	120,7	1,1	0,6	40	4,5	2,9	9,3	2,2	101	124	124	1	0,6
	108	120,7	1,1	0,6	40	4,5	2,9	9,3	2,2	101	124	124	1	0,6
	113,7	130	1,5	1	28	5,2	4,2	13,4	2,2	102	138	138	1,5	1
	113,7	130	1,5	1	28	5,2	4,2	13,4	2,2	102	138	138	1,5	1
	113,7	130	1,5	1	40	5,2	4,2	13,4	2,2	102	138	138	1,5	1
	113,7	130	1,5	1	40	5,2	4,2	13,4	2,2	102	138	138	1,5	1
100	115	128,7	1,1	0,6	29	4,5	2,9	10,9	2,2	106	134	134	1	0,6
	115	128,7	1,1	0,6	29	4,5	2,9	10,9	2,2	106	134	134	1	0,6
	115	128,7	1,1	0,6	41	4,5	2,9	10,9	2,2	106	134	134	1	0,6
	115	128,7	1,1	0,6	41	4,5	2,9	10,9	2,2	106	134	134	1	0,6
	118,7	135	1,5	1	29	5,2	4,2	13,4	2,2	107	143	143	1,5	1
	118,7	135	1,5	1	29	5,2	4,2	13,4	2,2	107	143	143	1,5	1
	118,7	135	1,5	1	41	5,2	4,2	13,4	2,2	107	143	143	1,5	1
	118,7	135	1,5	1	41	5,2	4,2	13,4	2,2	107	143	143	1,5	1

Super-precision angular contact ball bearings
d 110 – 120 mm

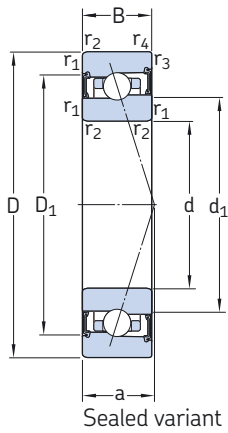

Sealed variant



Open variant

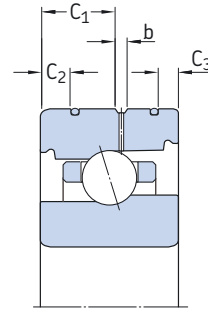

Open variant for direct oil lubrication

Principal dimensions			Basic load ratings dynamic ¹⁾ static		Fatigue load limit	Calculation factor	Attainable speed when lubricating with grease oil-air ²⁾		Mass ³⁾	Designations of sealed bearings ⁴⁾ SKF SNFA	
d	D	B	C	C ₀	P _u	f ₀					
mm			kN		kN	–	r/min		kg	–	
110	150	20	26	27	1	10	11 000	17 000	0,93	S71922 CB/P4A	HB110 /S 7CE1
	150	20	26	27	1	10	14 000	22 000	0,87	S71922 CB/HCP4A	HB110 /S/NS 7CE1
	150	20	24,7	25,5	0,95	–	10 000	15 000	0,93	S71922 ACB/P4A	HB110 /S 7CE3
	150	20	24,7	25,5	0,95	–	12 000	19 000	0,87	S71922 ACB/HCP4A	HB110 /S/NS 7CE3
	170	28	37,1	36	1,29	9,7	10 000	16 000	2,20	S7022 CB/P4A	HX110 /S 7CE1
	170	28	37,1	36	1,29	9,7	12 000	19 000	2,10	S7022 CB/HCP4A	HX110 /S/NS 7CE1
	170	28	35,1	34	1,22	–	9 000	14 000	2,20	S7022 ACB/P4A	HX110 /S 7CE3
	170	28	35,1	34	1,22	–	11 000	16 000	2,10	S7022 ACB/HCP4A	HX110 /S/NS 7CE3
120	165	22	27	30,5	1,08	10	10 000	16 000	1,30	S71924 CB/P4A	HB120 /S 7CE1
	165	22	27	30,5	1,08	10	12 000	20 000	1,20	S71924 CB/HCP4A	HB120 /S/NS 7CE1
	165	22	25,5	28,5	1,02	–	9 000	14 000	1,30	S71924 ACB/P4A	HB120 /S 7CE3
	165	22	25,5	28,5	1,02	–	11 000	17 000	1,20	S71924 ACB/HCP4A	HB120 /S/NS 7CE3
	180	28	37,7	39	1,34	9,8	9 500	14 000	2,35	S7024 CB/P4A	HX120 /S 7CE1
	180	28	37,7	39	1,34	9,8	11 000	17 000	2,20	S7024 CB/HCP4A	HX120 /S/NS 7CE1
	180	28	35,8	36,5	1,27	–	8 500	13 000	2,35	S7024 ACB/P4A	HX120 /S 7CE3
	180	28	35,8	36,5	1,27	–	10 000	15 000	2,20	S7024 ACB/HCP4A	HX120 /S/NS 7CE3

¹⁾ The basic dynamic load ratings listed in the product tables are calculated in accordance with ISO 281:2007 and cannot be compared with ratings calculated by other calculation methods.

²⁾ Applicable to open bearings only

³⁾ Applicable to sealed bearings only

⁴⁾ For designations of open bearings and other variants, refer to **table 15** on **pages 32** and **33**.

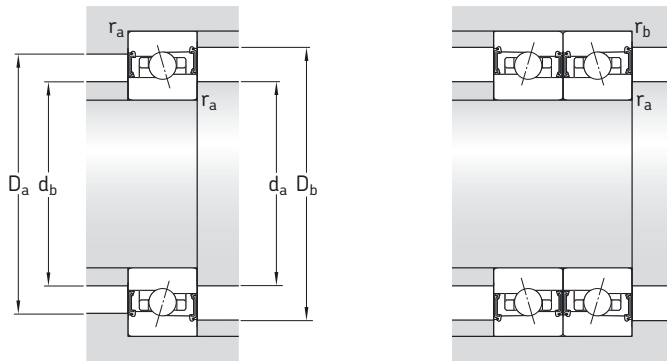

C

Dimensions

Abutment and fillet dimensions

d	d ₁ ~	D ₁ ~	r _{1,2} min	r _{3,4} min	a	C ₃	C ₂	C ₁	b	d _a , d _b min	D _a max	D _b max	r _a max	r _b max
mm										mm				
110	124,5	139	1,1	0,6	33	4,5	2,9	10,9	2,2	116	144	144	1	0,6
	124,5	139	1,1	0,6	33	4,5	2,9	10,9	2,2	116	144	144	1	0,6
	124,5	139	1,1	0,6	47	4,5	2,9	10,9	2,2	116	144	144	1	0,6
	124,5	139	1,1	0,6	47	4,5	2,9	10,9	2,2	116	144	144	1	0,6
	133,2	151,9	2	1	33	6,2	4,2	15,1	2,2	119	161	161	2	1
	133,2	151,9	2	1	33	6,2	4,2	15,1	2,2	119	161	161	2	1
	133,2	151,9	2	1	47	6,2	4,2	15,1	2,2	119	161	161	2	1
	133,2	151,9	2	1	47	6,2	4,2	15,1	2,2	119	161	161	2	1
120	137	151,9	1,1	0,6	34	4,5	2,9	11,9	2,2	126	159	159	1	0,6
	137	151,9	1,1	0,6	34	4,5	2,9	11,9	2,2	126	159	159	1	0,6
	137	151,9	1,1	0,6	49	4,5	2,9	11,9	2,2	126	159	159	1	0,6
	137	151,9	1,1	0,6	49	4,5	2,9	11,9	2,2	126	159	159	1	0,6
	143,2	161,9	2	1	34	6,3	4,3	15,1	2,2	129	171	171	2	1
	143,2	161,9	2	1	34	6,3	4,3	15,1	2,2	129	171	171	2	1
	143,2	161,9	2	1	49	6,3	4,3	15,1	2,2	129	171	171	2	1
	143,2	161,9	2	1	49	6,3	4,3	15,1	2,2	129	171	171	2	1

Setting the highest standard for precision bearings

SKF has developed and is continuing to develop a new, improved generation of super-precision bearings. The new assortment delivers improved accuracy and extended bearing service life when compared to previous designs.

Table 1 on **page 44** and **45** provides an overview of the new assortment of SKF super-precision bearings.

Super-precision angular contact ball bearings

Bearings in the 718 (SEA) series

Bearings in the 718 (SEA) series provide optimum performance in applications where a low cross section and high degree of rigidity, speed and superior accuracy are critical design parameters. They are particularly suitable for machine tool applications, multi-spindle drilling heads, robotic arms, measuring devices, racing car wheels and other precision applications. The standard assortment accommodates shaft diameters ranging from 10 to 160 mm.

Bearings in the 719 .. D (SEB) and 70 .. D (EX) series

For applications where a high load carrying capacity is an additional operational requirement, SKF offers high-capacity bearings in the 719 .. D (SEB) and 70 .. D (EX) series. The ability of the new design super-precision bearings in these two series to accommodate heavy loads in applications where radial space is often limited, makes them an excellent choice for demanding applications. Open bearings in the 719 .. D (SEB) series accommodate shaft diameters ranging from 10 to 360 mm; sealed bearings from 10 to 150 mm.

Open bearings in the 70 .. D (EX) series accommodate shaft diameters ranging from 6 to 240 mm; sealed bearings from 10 to 150 mm.

Bearings in the 719 .. E (VEB) and 70 .. E (VEX) series

Compared to high-speed B design bearings, high-speed E design bearings have a higher speed capability and can accommodate heavier loads. This desirable combination makes these bearings an excellent choice for demanding applications.

Open bearings in the 719 .. E (VEB) series accommodate shaft diameters ranging from 8 to 120 mm; sealed bearings from 20 to 120 mm. Open bearings in the 70 .. E (VEX) series accommodate shaft diameters ranging from 6 to 120 mm; sealed bearings from 10 to 120 mm.



Bearings in the 72 .. D (E 200) series

High-capacity bearings in the 72 .. D (E 200) series offer solutions to many bearing arrangement challenges. Their ability, among others, to provide a high degree of rigidity and accommodate heavy loads at relatively high speeds, is beneficial for a variety of applications. The extended range of bearings in this series now accommodates shaft diameters ranging from 7 to 140 mm. And, there is also a relubrication-free, sealed variant, available on request.



Bearings made from NitroMax steel

In extremely demanding applications such as high-speed machining centres and milling machines, bearings are frequently subjected to difficult operating conditions such as very high speeds, thin-film lubrication conditions, and contaminated and corrosive environments. To enable longer bearing service life and reduce the costs associated with downtime, SKF has developed a superior high-nitrogen steel.

The SKF assortment of super-precision angular contact ball bearings made from NitroMax steel have ceramic (bearing grade silicon nitride) rolling elements as standard.

Super-precision cylindrical roller bearings

SKF produces super-precision single row and double row cylindrical roller bearings. The characteristic features of these bearings are a low cross sectional height, high load carrying capacity, high rigidity and high-speed capability. They are therefore particularly well suited for machine tool spindles where the bearing arrangement must accommodate heavy radial loads and high speeds, while providing a high degree of stiffness.

Single row cylindrical roller bearings are produced in the N 10 series as basic design bearings and as high-speed design bearings. High-speed single row cylindrical roller bearings in the N 10 series are available with a tapered bore only and for shaft diameters ranging from 40 to 80 mm. Compared to previous high-speed design, they can accommodate a speed increase of up to 30% in grease lubricated applications and up to 15% in oil-air lubricated applications.

Double row cylindrical roller bearings are produced as standard in the NN design and NNU design.



Super-precision double direction angular contact thrust ball bearings

Double direction angular contact bearings, as their name implies, were developed by SKF to axially locate machine tool spindles in both directions.

The new optimized design of super-precision bearings in the BTW series consists of a set of two single row angular contact thrust ball bearings, arranged back-to-back. This configuration enables the bearings to accommodate axial loads in both directions while providing a high degree of system rigidity. These bearings can accommodate higher speeds compared to bearings in the former 2344(00) series. The bearings are available for shaft diameters ranging from 35 to 200 mm.

The redesigned high-speed BTM series accommodate higher speeds, anywhere from 6% to 12% depending on the size; minimize heat generation, even at higher speeds; provide high load carrying capacity and maintain a high degree of system rigidity. The range of BTM bearings series has been expanded to accommodate shaft diameters from 60 to 180 mm.



Super-precision angular contact thrust ball bearings for screw drives

Single direction angular contact thrust ball bearings in the BSA and BSD (BS) series are available for shaft diameters ranging from 12 to 75 mm. These bearings are characterized by superior axial stiffness and high axial load carrying capacity.

Double direction angular contact thrust ball bearings in the BEAS series have been developed for machine tool applications where space is tight and easy mounting is required. The bearings are available for shaft diameters ranging from 8 to 30 mm. Bearings in the BEAM series, which can accommodate shaft diameters ranging from 12 to 60 mm, can be bolt-mounted to an associated component.

Cartridge units are another solution for simple and quick mounting. Units in the FBSA (BSDU and BSQU) series incorporate SKF single direction angular contact thrust ball bearings and can accommodate shaft diameters ranging from 20 to 60 mm.

Super-precision axial-radial cylindrical roller bearings

SKF axial-radial cylindrical roller bearings are suitable for arrangements that have simultaneously acting (radial and axial) loads as well as moment loads.





Their internal design, together with close tolerance manufacturing processes, enable these bearings to attain better than P4 running accuracy.

Axial-radial cylindrical roller bearings are commonly used to support rotating tables, indexing tables and milling heads.



Table 1





Overview of SKF super-precision bearings

ISO dimension series	Bearing type and design <i>SKF publication^{1,2)}</i>		Variant	SKF assortment SKF bearings in the series		
18	Angular contact ball bearings: Basic design <i>Super-precision angular contact ball bearings: 718 (SEA) series (Publication No. 06810)</i>		Open	All-steel Hybrid	718 .. D (SEA) 718 .. D/H/C (SEA/NS)	
			Angular contact ball bearings: High-speed, B design <i>Super-precision angular contact ball bearings: High-speed, B design, sealed as standard (Publication No. 06939)</i>	Open	All-steel Hybrid	719 .. B (HB) 719 .. B/H/C (HB/NS)
				Sealed	All-steel Hybrid	S719 .. B (HB/S) S719 .. B/H/C (HB/S/NS)
				Angular contact ball bearings: High-speed, E design <i>Super-precision angular contact ball bearings: High-speed, E design (Publication No. 10112)</i>	Open	All-steel Hybrid
Sealed	All-steel Hybrid	S719 .. E (VEB/S) S719 .. E/H/C (VEB/S/NS)				
19	Angular contact ball bearings: High-capacity, basic design <i>Super-precision angular contact ball bearings: High-capacity 719 .. D (SEB) and 70 .. D (EX) series (Publication No. 10527)</i>		Open	All-steel Hybrid	719 .. D (SEB) 719 .. D/H/C (SEB/NS)	
			Sealed	All-steel Hybrid	S719 .. D (SEB/S) S719 .. D/H/C (SEB/S/NS)	
			Angular contact ball bearings: High-speed, B design <i>Super-precision angular contact ball bearings: High-speed, B design, sealed as standard (Publication No. 06939)</i>	Open	All-steel Hybrid	70 .. B (HX) 70 .. B/H/C (HX/NS)
				Sealed	All-steel Hybrid	S70 .. B (HX/S) S70 .. B/H/C (HX/S/NS)
10	Angular contact ball bearings: High-speed, E design <i>Super-precision angular contact ball bearings: High-speed, E design (Publication No. 10112)</i>		Open	All-steel Hybrid	70 .. E (VEX) 70 .. E/H/C (VEX/NS)	
			Sealed	All-steel Hybrid	S70 .. E (VEX/S) S70 .. E/H/C (VEX/S/NS)	
			Angular contact ball bearings: High-capacity, basic design <i>Super-precision angular contact ball bearings: High-capacity 719 .. D (SEB) and 70 .. D (EX) series (Publication No. 10527)</i>	Open	All-steel Hybrid	70 .. D (EX) 70 .. D/H/C (EX/NS)
Sealed	All-steel Hybrid	S70 .. D (EX/S) S70 .. D/H/C (EX/S/NS)				
02	Angular contact ball bearings: High-capacity, basic design <i>Super-precision angular contact ball bearings: High-capacity (Publication No. 06981)</i>		Open	All-steel Hybrid	72 .. D (E 200) 72 .. D/H/C (E 200/NS)	
			Sealed	All-steel Hybrid	S72 .. D (E 200/S) S72 .. D/H/C (E 200/S/NS)	
49	Double row cylindrical roller bearings: NNU design		Open	All-steel	NNU 49 BK	

¹⁾ Where applicable, information can be found in the SKF publication *High-precision bearings* (Publication No. 6002).

²⁾ For additional information about super-precision angular contact ball bearings made from NitroMax steel, refer to the SKF publication *Extend bearing service life with NitroMax* (Publication No. 10126).

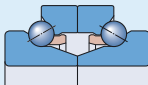
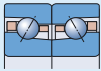
Overview of SKF super-precision bearings

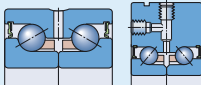
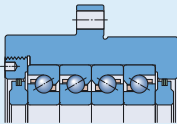
ISO dimension series	Bearing type and design <i>SKF publication^{1,2)}</i>		Variant		SKF assortment SKF bearings in the series
10	Single row cylindrical roller bearings: Basic design 		Open	All-steel Hybrid	N 10 KTN N 10 KTN/HC5
	Single row cylindrical roller bearings: High-speed design <i>Super-precision cylindrical roller bearings: High-speed (Publication No. 07016)</i> 		Open	All-steel Hybrid	N 10 KPHA N 10 KPHA/HC5
30	Double row cylindrical roller bearings: NN design 		Open	All-steel Hybrid	NN 30 KTN NN 30 KTN/HC5
– (Non-standardized)	Angular contact thrust ball bearings: Double direction, basic design <i>Super-precision double direction angular contact thrust ball bearings (Publication No. 10097)</i> 		Open	All-steel Hybrid	BTW BTW /HC
	Angular contact thrust ball bearings: Double direction, high-speed design <i>Higher-speed capability with the new BTM bearing series design (Publication No. 12119)</i> 		Open	All-steel Hybrid	BTM BTM /HC
02	Angular contact thrust ball bearings: Single direction <i>Super-precision angular contact thrust ball bearings for screw drives (Publication No. 06570)</i> 		Open Sealed	All-steel All-steel	BSA 2 (BS 200) BSA 2 .. (BS 200 ..)
03	Angular contact thrust ball bearings: Single direction <i>Super-precision angular contact thrust ball bearings for screw drives (Publication No. 06570)</i> 		Open Sealed	All-steel All-steel	BSA 3 (BS 3) BSA 3 .. (BS 3 ..)
– (Non-standardized)	Angular contact thrust ball bearings: Single direction <i>Super-precision angular contact thrust ball bearings for screw drives (Publication No. 06570)</i> 		Open Sealed	All-steel All-steel	BSD (BS ..) BSD .. (BS ..)
	Angular contact thrust ball bearings: Double direction 		Sealed	All-steel	BEAS (BEAS) BEAM (BEAM)
	Cartridge unit with angular contact thrust ball bearings 		Sealed	All-steel	FBSA (BSDU, BSQU) –

¹⁾ Where applicable, information can be found in the SKF publication *High-precision bearings* (Publication No. 6002).

²⁾ For additional information about super-precision angular contact ball bearings made from NitroMax steel, refer to the SKF publication *Extend bearing service life with NitroMax* (Publication No. 10126).



SKF – the knowledge engineering company

From the company that invented the self-aligning ball bearing more than 100 years ago, SKF has evolved into a knowledge engineering company that is able to draw on five technology platforms to create unique solutions for its customers. These platforms include bearings, bearing units and seals, of course, but extend to other areas including: lubricants and lubrication systems, critical for long bearing life in many applications; mechatronics that combine mechanical and electronics knowledge into systems for more effective linear motion and sensorized solutions; and a full range of services, from design and logistics support to condition monitoring and reliability systems.

Though the scope has broadened, SKF continues to maintain the world's leadership in the design, manufacture and marketing of rolling bearings, as well as complementary products such as radial seals. SKF also holds an increasingly important position in the market for linear motion products, high-precision aerospace bearings, machine tool spindles and plant maintenance services.

The SKF Group is globally certified to ISO 14001, the international standard for environmental management, as well as OHSAS 18001, the health and safety management standard. Individual divisions have been approved for quality certification in accordance with ISO 9001 and other customer specific requirements.

With over 120 manufacturing sites worldwide and sales companies in 70 countries, SKF is a truly international corporation. In addition, our distributors and dealers in some 15 000 locations around the world, an e-business marketplace and a global distribution system put SKF close to customers for the supply of both products and services. In essence, SKF solutions are available wherever and whenever customers need them. Overall, the SKF brand and the corporation are stronger than ever. As the knowledge engineering company, we stand ready to serve you with world-class product competencies, intellectual resources, and the vision to help you succeed.



© Airbus – photo: e*tm company, H. Goussé

Evolving by-wire technology

SKF has a unique expertise in the fast-growing by-wire technology, from fly-by-wire, to drive-by-wire, to work-by-wire. SKF pioneered practical fly-by-wire technology and is a close working partner with all aerospace industry leaders. As an example, virtually all aircraft of the Airbus design use SKF by-wire systems for cockpit flight control.

SKF is also a leader in automotive by-wire technology, and has partnered with automotive engineers to develop two concept cars, which employ SKF mechatronics for steering and braking. Further by-wire development has led SKF to produce an all-electric forklift truck, which uses mechatronics rather than hydraulics for all controls.

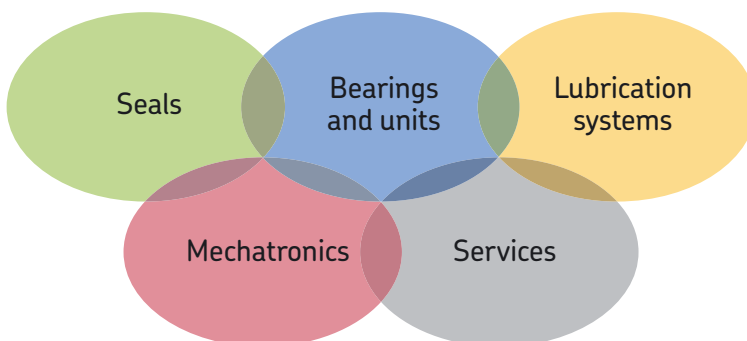



Harnessing wind power

The growing industry of wind-generated electric power provides a source of clean, green electricity. SKF is working closely with global industry leaders to develop efficient and trouble-free turbines, providing a wide range of large, highly specialized bearings and condition monitoring systems to extend equipment life of wind farms located in even the most remote and inhospitable environments.



Working in extreme environments

In frigid winters, especially in northern countries, extreme sub-zero temperatures can cause bearings in railway axleboxes to seize due to lubrication starvation. SKF created a new family of synthetic lubricants formulated to retain their lubrication viscosity even at these extreme temperatures. SKF knowledge enables manufacturers and end user customers to overcome the performance issues resulting from extreme temperatures, whether hot or cold. For example, SKF products are at work in diverse environments such as baking ovens and instant freezing in food processing plants.



Developing a cleaner cleaner

The electric motor and its bearings are the heart of many household appliances. SKF works closely with appliance manufacturers to improve their products' performance, cut costs, reduce weight, and reduce energy consumption. A recent example of this cooperation is a new generation of vacuum cleaners with substantially more suction. SKF knowledge in the area of small bearing technology is also applied to manufacturers of power tools and office equipment.



Maintaining a 350 km/h R&D lab

In addition to SKF's renowned research and development facilities in Europe and the United States, Formula One car racing provides a unique environment for SKF to push the limits of bearing technology. For over 60 years, SKF products, engineering and knowledge have helped make Scuderia Ferrari a formidable force in F1 racing. (The average racing Ferrari utilizes around 150 SKF components.) Lessons learned here are applied to the products we provide to automakers and the aftermarket worldwide.



Delivering Asset Efficiency Optimization

Through SKF Reliability Systems, SKF provides a comprehensive range of asset efficiency products and services, from condition monitoring hardware and software to maintenance strategies, engineering assistance and machine reliability programmes. To optimize efficiency and boost productivity, some industrial facilities opt for an Integrated Maintenance Solution, in which SKF delivers all services under one fixed-fee, performance-based contract.



Planning for sustainable growth

By their very nature, bearings make a positive contribution to the natural environment, enabling machinery to operate more efficiently, consume less power, and require less lubrication. By raising the performance bar for our own products, SKF is enabling a new generation of high-efficiency products and equipment. With an eye to the future and the world we will leave to our children, the SKF Group policy on environment, health and safety, as well as the manufacturing techniques, are planned and implemented to help protect and preserve the earth's limited natural resources. We remain committed to sustainable, environmentally responsible growth.

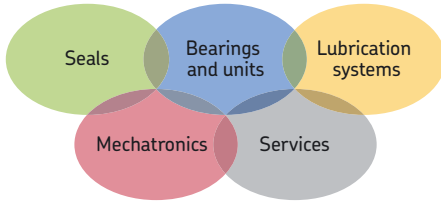

The Power of Knowledge Engineering

Drawing on five areas of competence and application-specific expertise amassed over more than 100 years, SKF brings innovative solutions to OEMs and production facilities in every major industry worldwide. These five competence areas include bearings and units, seals, lubrication systems, mechatronics (combining mechanics and electronics into intelligent systems), and a wide range of services, from 3-D computer modelling to advanced condition monitoring and reliability and asset management systems. A global presence provides SKF customers uniform quality standards and worldwide product availability.

© SKF and SNFA are registered trademarks of the SKF Group.

© SKF Group 2012

The contents of this publication are the copyright of the publisher and may not be reproduced (even extracts) unless prior written permission is granted. Every care has been taken to ensure the accuracy of the information contained in this publication but no liability can be accepted for any loss or damage whether direct, indirect or consequential arising out of the use of the information contained herein.

PUB BU/P2 06939/5 EN · February 2012

This publication supersedes all information about SKF bearings in the 719 .. B and 70 .. B series in the SKF publication 6002 EN High-precision bearings, and SNFA bearings in the HB and HX series in the SNFA General Catalogue.

