

# EFFP electrical grease feed pump

for the filling of pumps or for simple lubrication tasks

# Operating instructions

acc. to EC Dir. 2006/42/EC

EN



Version 05



## Masthead

These operating instructions pursuant to EC Machinery Directive 2006/42/EC are an integral part of the described product and must be kept for future use.

These operating instructions have been prepared in accordance with the established standards and rules for technical documentation, VDI 4500 and EN 292.

## © SKF Lubrication Systems Germany GmbH

This documentation is protected by copyright. SKF Lubrication Systems reserves all rights, including those to the photomechanical reproduction, duplication, and distribution by means of special procedures (e.g., data processing, data media, and data networks) of this documentation in whole or in part.

Subject to changes in contents and technical information.

## Service

If you have technical questions, please contact the following addresses:

### SKF Lubrication Systems Germany GmbH

#### Berlin Plant

Motzener Strasse 35/37

12277 Berlin

Germany

Tel. +49 (0)30 72002-0

Fax +49 (0)30 72002-111

[www.skf.com/lubrication](http://www.skf.com/lubrication)

#### Hockenheim Plant

2. Industriestrasse 4

68766 Hockenheim

Germany

Tel. +49 (0)62 05 27-0

Fax +49 (0)62 05 27-101

[www.skf.com/lubrication](http://www.skf.com/lubrication)

## Table of contents

EFFP electrical grease feed pump	1	<b>3. Transport, delivery, and storage</b>	<b>14</b>	<b>7. Shutdown and disposal</b>	<b>27</b>
Information concerning EC Declaration of Conformity and EC Declaration of Incorporation	4	3.1 Lubrication units	14	7.1 Temporary shutdown	27
Explanation of symbols and signs	5	3.2 Electronic and electrical devices	14	7.2 Permanent shutdown	27
<b>1. Safety instructions</b>	<b>6</b>	3.3 General notes	14	<b>8. Maintenance</b>	<b>28</b>
1.1 Authorized personnel	6	<b>4. Overview/Functional description</b>	<b>15</b>	8.1 General information	28
1.2 Electric shock hazard	7	4.1 Overview	15	8.2 Visual inspection	29
1.3 System pressure hazard	7	4.2 Design of EFFP	16	8.3 Service	29
1.4 Hoisting hazard	7	4.3 Functional description of EFFP	16	<b>9. Malfunctions, causes, and remedies</b>	<b>30</b>
1.5 Pre-commissioning information	7	<b>5. Assembly</b>	<b>18</b>	<b>10. Technical data</b>	<b>31</b>
1.6 Replacing the grease pail	7	5.1 General information	18	<b>11. Spare parts</b>	<b>32</b>
1.7 Intended use	8	5.2 Assembly		<b>12. Accessories</b>	<b>34</b>
1.8 Disclaimer of liability	8	5.2.1 Installing the EFFP in the upper frame section	20		
1.9 Existing residual risks	9	5.2.2 Installation of grease pail and grease follower plate	21		
<b>2. Lubricants</b>	<b>11</b>	5.2.3 Installation of the filling fitting	22		
2.1 General information	11	<b>6. Operation</b>	<b>23</b>		
2.2 Selection of lubricants	11	6.1 General information	23		
2.3 Approved lubricants	12	6.2 Note on the rating plate	24		
2.4 Lubricants and the environment	13	6.3 Commissioning	25		
2.5 Lubricant hazards	13	6.4 Grease reservoir replacement	26		
		6.5 Signal input device for external filling level monitoring	27		

## EC declaration of conformity following machinery directive 2006/42/EC, Annex II Part 1 A

The manufacturer— SKF Lubrication Systems Germany GmbH, Hockenheim Facilities, 2. Industriestrasse 4 Germany, - 68766 Hockenheim — hereby declares that the machinery

Designation: **Electrical grease feed pump**  
 Type: **EFFP**  
 Part number: **24-1560-3577; 24-1560-3578; 24-1560-3580; 24-1560-3581**  
 Year of construction: See type identification plate  
 complies with the following basic safety and health requirements of the EC machinery directive 2006/42/EC at the time when first being launched in the market.

The special technical documents were prepared following Annex VII part A of this directive. Upon justifiable request, these special technical documents can be forwarded electronically to the respective national authorities. The person empowered to assemble the technical documentation on behalf of the manufacturer is the head of standardization, See manufacturer's address.

Furthermore, the following directives and harmonized standards were applied in the respective applicable areas:

2011/65/EU                      RoHS II  
 2014/30/EU                      Electromagnetic compatibility | Industry

Standard	Edition	Standard	Edition	Standard	Edition	Standard	Edition
EN ISO 12100	2011	DIN EN 60947-5-1	2010	DIN EN 61000-6-2	2006	DIN EN 60947-5-1	2010
DIN EN 809	2012	DIN EN 61131-2	2008	Berichtigung	2011		
DIN EN 60204-1	2007	Berichtigung	2009	DIN EN 61000-6-3	2011		
Berichtigung	2010	DIN EN 60034-1	2011	Berichtigung	2012		
DIN EN 50581	2013	DIN EN 61000-6-1	2007	DIN EN 61000-6-4	2011		

Hockenheim, 2016/25/04

Jürgen Kreuzkämper  
 Manager R&D Germany  
 SKF Lubrication Business Unit



Stefan Schürmann  
 Manager R&D Hockenheim/Walldorf  
 SKF Lubrication Business Unit



## Explanation of symbols and signs

You will find these symbols, which warn of specific dangers to persons, material assets, or the environment, next to all safety instructions in these operating instructions.

Please heed these instructions and proceed with special care in such cases. Please forward all safety instructions to other users.

Instructions placed directly on the machines/ grease lubrication pump units, such as:

- Arrow indicators
  - Labels for fluid connections
- must be followed and kept in fully legible condition.



### You are responsible!

Please read the assembly and operating instructions thoroughly and follow the safety instructions.

#### Hazard symbols



General hazard  
DIN 4844-2-W000



Electrical voltage/current  
DIN 4844-2-W008



Hot surface  
DIN 4844-2-W026



Danger of being drawn into machinery  
BGV 8A



Slipping hazard  
DIN 4844-2-W028

#### Safety signal words and their meaning

##### Signal word meaning

Danger!	Risk of serious injury or death
Warning!	Risk of damage to property and the environment
Note!	Provides additional information

#### Informational symbols



Note

- Prompts an action
- Used for itemizing
- ➔ Refers to other facts, causes, or consequences
- ☞ Provides additional information
-  Environmentally correct disposal

# 1. Safety instructions

 The operator of the described product must ensure that the operating instructions are read and understood by all persons responsible for assembly, operation, maintenance, and repair of the product. The operating instructions must be kept readily available.

 Note that the operating instructions form part of the product and must accompany the product if sold to a new owner.

The described product is manufactured in accordance with the generally accepted rules and standards of industry practice and with occupational safety and accident prevention regulations. Risks may, however, arise from its usage and may result in physical harm to persons or damage to other material assets. Therefore the product may only be used in proper technical condition and in observance of the operating instructions. In particular, any malfunctions

which may affect safety must be remedied immediately.

 In addition to the operating instructions, statutory regulations and other general regulations for accident prevention and environmental protection must be observed and applied.

## 1.1 Authorized personnel

Only qualified technical personnel may install, operate, maintain, and repair the products described in the operating instructions. Qualified technical personnel are persons who have been trained, assigned, and instructed by the operator of the final product into which the described product is incorporated. Such persons are familiar with the relevant standards, rules, accident prevention regulations, and assembly conditions as a result of their training, experience, and instruction. They are authorized to identify and perform necessary actions while avoiding any risks which may arise.

The definition of qualified personnel and the prohibition against employing non-qualified personnel are laid down in DIN VDE 0105 and IEC 364.

## 1.2 Electric shock hazard

Electrical connections for the described product may only be established by qualified and trained personnel authorized to do so by the operator, and in observance of the local electrical operating conditions and local regulations (e.g., DIN, VDE). Significant bodily injury and property damage may result from improperly connected products.



### **Danger!**

Performing work on an energized pump or product may result in serious injury or death. Assembly, maintenance and repair work may only be performed on products that have been de-energized by qualified technical personnel. The supply voltage must be switched off before opening any of the product's components.

## 1.3 System pressure hazard



Lubrication systems are pressurized during operation. Centralized lubrication systems must therefore be depressurized before starting assembly, maintenance or repair work, or any system modifications or decommissioning.

## 1.4 Hoisting hazard



The EFP electrical grease feed pump can be transported using a crane. Never stand under the EFP during transport. Ensure that nobody is present below the load during transport.

## 1.5 Pre-commissioning information



Commissioning is prohibited until these operating instructions have been read and understood. Inspect the electrical grease feed pump for external damage before each use.

When filling lubricant into the pump, make sure the lubricant is clean. The reservoir must be filled in good time.

## 1.6 Replacing the grease pail



When replacing the grease pail, ensure that the palm grips are tightened and have been secured against loosening using the spring cotters; see Chapter 5.2, Assembly.

## 1.7 Intended use

The EFP electrical grease feed pump is suitable for mobile use. It is used to fill lubrication pumps or as a lubricating aid for progressive feeder systems.

Greases up to a maximum effective flow pressure of 700 mbar are supported, including greases based on mineral oil as well as environmentally friendly and synthetic oils and greases.

The pump fits common grease drums (also referred to as hobbocks) with capacities from 16 to 25 kg.

The technical data presented in Chapter 10 must be observed for intended use.

Any other usage is deemed non-compliant with the intended use.

Hazardous materials of any kind, especially the materials classified as hazardous by CLP Regulation EC 1272/2008 may only be used to fill SKF centralized lubrication systems and components and delivered and/or distributed with the same after consulting with and receiving written approval from SKF.

The product described here is neither designed nor approved for use in conjunction with gases, liquefied gases, pressurized gases in solution, vapors and such fluids whose vapor pressure exceeds normal atmospheric pressure (1013 mbar) by more than 0.5 bar at their maximum permissible temperature.

Unless specially indicated otherwise, products from SKF Lubrication Systems Germany GmbH are not approved for use in potentially explosive areas as defined in the ATEX Directive 2014/34/EC.

## 1.8 Disclaimer of liability

SKF Lubrication Systems shall not be responsible for damages:

- Caused by contaminated or unsuitable lubricants
- Caused by the installation of non-original SKF components or SKF spare parts
- Caused by inappropriate usage
- Resulting from improper assembly, configuration or filling
- Resulting from improper response to malfunctions
- Caused by independent modification of system components
- Only media approved for these types of pump units may be used. Unsuitable media may result in pump unit failure and potentially severe bodily injury and property damage.



### 1.9 Existing residual risks (residual risk assessment)

Residual risk	Remedy
<b>Life cycle: Assembly</b>	
Electric shock due to defective power lead/mains plug	<ul style="list-style-type: none"> <li>• Inspect the power lead/mains plug for damage before starting the EFP electrical grease feed pump.</li> </ul>
People slipping due to floor contamination with spilled/leaked lubricant	<ul style="list-style-type: none"> <li>• Exercise caution during filling.</li> <li>• Promptly apply suitable agents and remove the bound leaked/spilled lubricant.</li> <li>• Follow operational instructions for handling lubricants and contaminated parts.</li> </ul>
Tearing/damage to lines when installed on moving machine components	<ul style="list-style-type: none"> <li>• If possible, do not install on moving parts; if this cannot be avoided, use flexible hose lines.</li> </ul>
<b>Life cycle: Commissioning/operation</b>	
Electric shock due to defective power lead/mains plug	<ul style="list-style-type: none"> <li>• Inspect the power lead/mains plug for damage before starting the EFP.</li> </ul>
Lubricating oil spraying out due to faulty component fitting/line connection.	<ul style="list-style-type: none"> <li>• Tighten all components by hand or using the specified torques. Use hydraulic connections and lines suitable for the indicated pressures. These must be checked for proper connection and for damage prior to commissioning.</li> </ul>
People slipping due to floor contamination with spilled/leaked lubricant	<ul style="list-style-type: none"> <li>• Exercise caution during filling.</li> <li>• Promptly apply suitable agents and remove the bound leaked/spilled lubricant.</li> <li>• Follow operational instructions for handling lubricants and contaminated parts.</li> </ul>
<b>Life cycle: Setup, retrofit</b>	
People slipping due to floor contamination with spilled/leaked lubricant	<ul style="list-style-type: none"> <li>• Exercise caution during filling.</li> <li>• Promptly apply suitable agents and remove the bound leaked/spilled lubricant.</li> <li>• Follow operational instructions for handling lubricants and contaminated parts.</li> </ul>

Residual risk	Remedy
<b>Life cycle: Malfunctions, troubleshooting</b>	
Electric shock due to defective power lead/ mains plug	<ul style="list-style-type: none"> <li>• Inspect the power lead/mains plug for damage before starting the EFPF.</li> </ul>
Electric shock from open electric motor or active energized components	<ul style="list-style-type: none"> <li>• Disconnect the mains plug (cut power) before performing any work on electrical components.</li> <li>• Exercise caution when winding and unwinding the power lead and when operating the EFPF.</li> </ul>
Strong heating of the electric motor due to a motor jam or continuous duty	<ul style="list-style-type: none"> <li>• Turn off the pump motor and let it cool down. Remedy the cause</li> </ul>
People slipping due to floor contamination with spilled/leaked lubricant	<ul style="list-style-type: none"> <li>• Exercise caution during filling.</li> <li>• Promptly apply suitable agents and remove the bound leaked/spilled lubricant.</li> <li>• Follow operational instructions for handling lubricants and contaminated parts.</li> </ul>
<b>Life cycle: Maintenance, repair</b>	
Electric shock due to defective power lead/ mains plug	<ul style="list-style-type: none"> <li>• Inspect the power lead/mains plug for damage before performing maintenance work on the EFPF.</li> </ul>
Electric shock	<ul style="list-style-type: none"> <li>• Disconnect the mains plug to de-energize the EFPF and its terminal box prior to maintenance work.</li> </ul>
People slipping due to floor contamination with spilled/leaked lubricant	<ul style="list-style-type: none"> <li>• Exercise caution during filling.</li> <li>• Promptly apply suitable agents and remove the bound leaked/spilled lubricant.</li> <li>• Follow operational instructions for handling lubricants and contaminated parts.</li> </ul>
<b>Life cycle: Decommissioning, disposal</b>	
Environmental contamination by lubricants and wetted parts	<ul style="list-style-type: none"> <li>• Dispose of contaminated parts according to the applicable legal/company rules.</li> </ul>
People slipping due to floor contamination with spilled/leaked lubricant	<ul style="list-style-type: none"> <li>• Exercise caution during filling.</li> <li>• Promptly apply suitable agents and remove the bound leaked/spilled lubricant.</li> <li>• Follow operational instructions for handling lubricants and contaminated parts.</li> </ul>

## 2. Lubricants

### 2.1 General information



All products from SKF Lubrication Systems may be used only for their intended purpose and in accordance with the information in the product's operating instructions.

Intended use is the use of the products for the purpose of providing centralized lubrication/ lubrication of bearings and friction points using lubricants within the physical usage limits which can be found in the documentation for the devices, e.g., operating instructions and the product descriptions, e.g., technical drawings and catalogs.

Hazardous materials of any kind, especially the materials classified as hazardous by CLP Regulation EC 1272/2008 may only be used to fill SKF centralized lubrication systems and components and delivered and/or distributed with the same after consulting with and receiving written approval from SKF.

No products manufactured by SKF Lubrication Systems are approved for use in conjunction

with gases, liquefied gases, pressurized gases in solution, vapors, or such fluids whose vapor pressure exceeds normal atmospheric pressure (1013 mbar) by more than 0.5 bar at their maximum permissible temperature. Other media which are neither lubricant nor hazardous substance may only be fed after consulting with and obtaining written approval from SKF Lubrication Systems. SKF Lubrication Systems considers lubricants to be an element of system design which must always be factored into the selection of components and the design of centralized lubrication systems. The lubricating properties of the lubricants are critically important in making these selections.

### 2.2 Selection of lubricants



Observe the instructions from the machine manufacturer regarding the lubricants that are to be used.



#### **Warning!**

The amount of lubricant required at a lubrication point is specified by the bearing or machine manufacturer. It must be ensured that the required quantity of lubricant is provided to the lubrication point. The lubrication point may otherwise not receive adequate lubrication, which can lead to damage and failure of the bearing.

Selection of a lubricant suitable for the lubrication task is made by the machine/system manufacturer and/or the operator of the machine/system in cooperation with the lubricant supplier.

The bearings/friction points that require lubrication, their expected load during operation, and the expected ambient conditions are taken into account during selection. All economic and

environmental aspects must also be considered.



If required, SKF Lubrication Systems can help customers to select suitable components for feeding the selected lubricant and to plan and design their centralized lubrication system.

Please contact SKF Lubrication Systems if you have further questions regarding lubricants. Lubricants can be tested in the company's laboratory for their suitability for pumping in centralized lubrication systems (e.g., "bleeding").

You can request an overview of the lubricant tests offered by SKF Lubrication Systems from the company's Service department.

### 2.3 Approved lubricants



#### **Warning!**

Only lubricants approved for the product may be used. Unsuitable lubricants can lead to failure of the product and to property damage.



#### **Warning!**

Different lubricants must not be mixed together. Doing so can cause damage and require costly and complicated cleaning of the product/lubrication system. It is recommended that an indication of the lubricant in use be attached to the lubricant reservoir in order to prevent accidental mixing of lubricants.

The product described here can be operated using lubricants that meet the specifications in the technical data. Depending on the product design, these lubricants may be oils, fluid greases, or greases.

Oils and base oils may be mineral, synthetic and/or rapidly biodegradable. Consistency agents and additives may be added depending on the operating conditions.

Note that in rare cases, there may be lubricants whose properties are within permissible limit values but whose other characteristics render them unsuitable for use in centralized lubrication systems. For example, synthetic lubricants may be incompatible with elastomers.

## 2.4 Lubricants and the environment



### Warning!

Lubricants can contaminate soil and bodies of water. Lubricants must be properly used and disposed of. Observe the local regulations and laws regarding the disposal of lubricants.

It is important to note that lubricants are environmentally hazardous, flammable substances which require special precautionary measures during transport, storage, and processing. Consult the safety data sheet from the lubricant manufacturer for information regarding transport, storage, processing, and environmental hazards of the lubricant that will be used.

The safety data sheet for a lubricant can be requested from the lubricant manufacturer.

## 2.5 Lubricant hazards



### Danger!

Filling pumps must always be free of leaks. Leaking lubricant is hazardous due to the risk of slipping and injury. Beware of any lubricant leaking out during assembly, operation, maintenance, or repair of centralized lubrication systems. Leaks must be sealed off without delay.

Lubricant leaking from centralized lubrication systems is a serious hazard. Leaking lubricant can create risks that may result in physical harm to persons or damage to other material assets.



### Warning!

Follow the safety instructions on the lubricant's safety data sheet.

Lubricants are a hazardous substance. The safety instructions on the lubricant's safety data sheet must be strictly followed. The safety data sheet for a lubricant can be requested from the lubricant manufacturer.

## 3. Transport, delivery, and storage

SKF Lubrication Systems products are packaged in accordance with standard commercial practice according to the regulations of the recipient's country and DIN ISO 9001. During transport, safe handling must be ensured and the product must be protected from mechanical effects such as impacts. The transport packaging must be marked "Do not drop!"



Warning!

The product must not be tilted or dropped.

There are no restrictions for land, air or sea transport.

After receipt of the shipment, the product(s) must be inspected for damage and for completeness according to the shipping documents. The packaging material must be preserved until any discrepancies are resolved. SKF Lubrication Systems products are subject to the following storage conditions:

### 3.1 Lubrication units

- Ambient conditions: Dry and dust-free surroundings, storage in well ventilated dry area
- Storage time: Max. 24 months
- Permissible humidity: < 65%
- Storage temperature: -10 to 60°C
- Light: Avoid direct sun or UV exposure and shield nearby sources of heat

### 3.2 Electronic and electrical devices

- Ambient conditions: Dry and dust-free surroundings, storage in well ventilated dry area
- Storage time: Max. 24 months
- Permissible humidity: < 65%
- Storage temperature: -10 to 60°C
- Light: Avoid direct sun or UV exposure and shield nearby sources of heat

### 3.3 General notes

- The product(s) can be enveloped in plasticfilm to provide low-dust storage.
- Protect against ground moisture by storing on a shelf or wooden pallet.
- Bright-finished metallic surfaces, especially wearing parts and assembly surfaces, must be protected using long-term anti-corrosive agents before storage.
- At approx. 6-month intervals: Check for corrosion. If there are signs of corrosion, reapply anti-corrosive agents.
- Drives must be protected from mechanical damage.

## 4. Overview/Functional description

### 4.1 Overview

Item	Description
1	Piston pump unit
1.1	Mains plug with cable
1.2	ON/OFF switch
1.3	Signal input for external filling level monitoring
2	Grease follower plate
3	Carrying frame with machine mount (complete, optionally available with handle)
3.1	Tie-rod
3.2	Baseplate
3.3	Palm grip
3.4	Spring cotter with safety chain
3.5	Reservoir centering (centering rubber strips)
3.6	Machine mount
4	Chassis (complete)
4.1	Wheelset
5	Carrying handles
6	Filling fitting with grease gun
7	Filling fitting with coupling socket

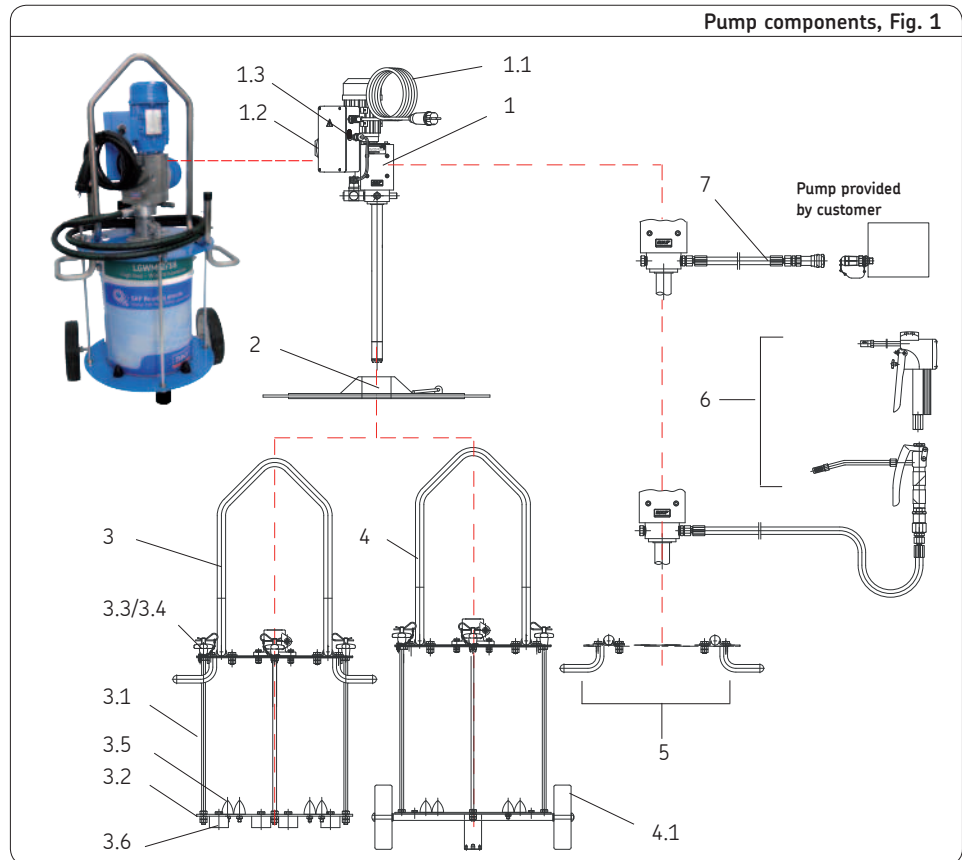

## 4.2 Design of EFP

The EFP electrical grease feed pump is designed as a piston pump for grease pail capacities from 16 to 25 kg. It is driven by a 230 V/50 Hz AC motor which powers a worm drive with an eccentric shaft. The eccentric shaft then controls a delivery piston which generates a delivery stroke at the end of the intake tube.

The EFP is activated using an ON/OFF switch attached to the terminal box.

An automatic switch-off function is integrated standard. The pump motor is switched off once the non-adjustable cutoff pressure of 100 bar is reached. The motor is switched on automatically after pressure drops (below the cutoff pressure). This technology makes it possible to, for example, use a high-pressure gun to lubricate individual lubrication points.

The EFP has a modular design. The basic design is supplied with a carrying frame. The EFP is optionally available with external signal monitoring, which can be used for maximum

fill level monitoring using customer equipment, for example.

A wheelset and carrying handles as well as a comprehensive range of accessories are also available (see page 15 and the Accessories chapter).

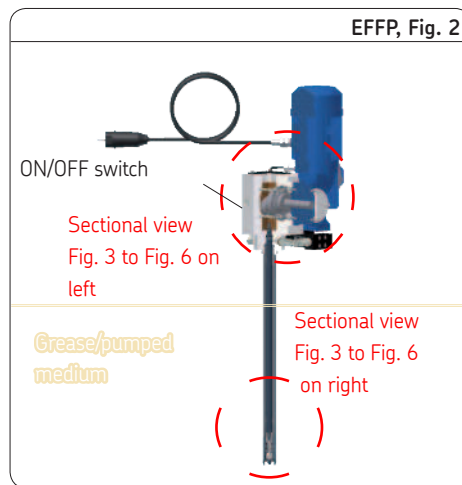

## 4.3 Functional description of EFP

A complete delivery stroke is divided into the following steps:

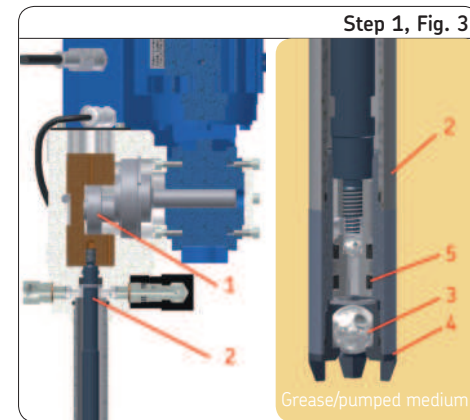

### Step 1

The EFP is in the starting position and the eccentric shaft (1) with piston rod (2) is in its lower end position. The check ball (3) is connected to the screw piece (4). The piston chamber (5) is closed and free of lubricant.



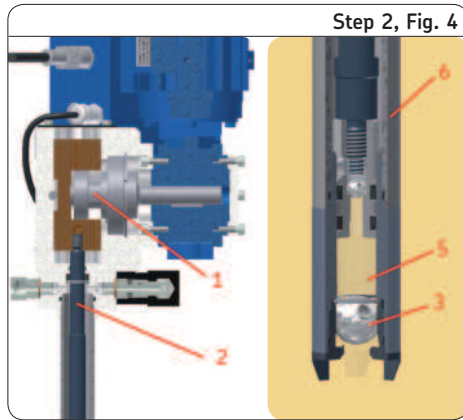

### Step 2

The rotation of the eccentric shaft (1) moves the piston rod (2) towards the upper end position. The suction effect thus generated in the piston chamber (5) lifts the check ball (3). The pumped medium flows past the check ball (3) and fills the piston chamber (5).

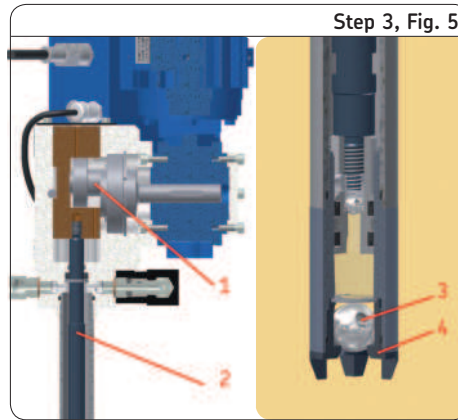

### Step 3

Once the upper end position has been reached, the continued rotation of the eccentric shaft (1) causes the piston rod (2) to sink. The check ball (3) contacts the screw piece (4) and prevents the pumped medium from flowing back.

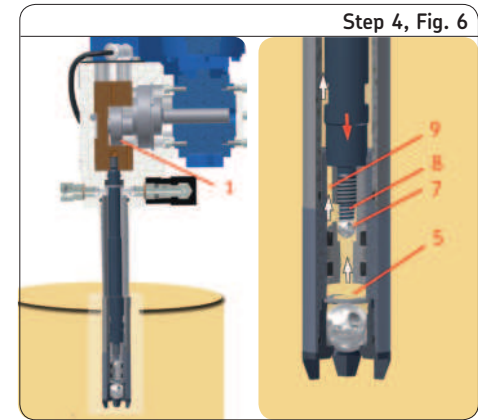

### Step 4

Pressure rises in the piston chamber (5). The riser ball (7) is thus pressed against the pressure spring (8) and allows the pumped medium to flow to the riser pipe (9). The piston chamber (5) is emptied once the lower end position is reached.

A complete delivery stroke with a maximum displacement of 6 cm<sup>3</sup> (depending on the lubricant) has thus been executed.

## 5. Assembly

### 5.1 General information



#### **Danger!**

See safety instructions in Chapter 1.1. Disconnect the mains plug from the power outlet.

The EFP grease feed pump is used to fill pumps, as a lubricating aid for progressive feeders, or as a mobile pump for service calls. The EFP and its accessories are available in various designs as the following kits:

#### **EFP electrical grease feed pump**

optional versions

- o Pump design 100 bar /0,4 l/min
- o Pump design 250 bar /0,2 l/min
- o Pump design 250 bar /0,4 l/min with/without
- o Pump design with signal input (external control)

#### **Frame for grease pail (complete)**

- o Carrying frame with machine mount
- o Carrying frame with machine mount and carrying handles
- o Chassis
- o Chassis with carrying handles

#### **Grease follower plate**

- o For pail diameter 265 to 285 mm
- o For pail diameter 285 to 305 mm
- o For pail diameter 305 to 350 mm

#### **Accessories**

<b>Electrical grease feed pump</b>	<b>Order No</b>
Pump design 100 bar /0,4 l/min	24-1560-3556
Pump design 100 bar /0,4 l/min with signal monitoring	24-1560-3570
Pump design 250 bar /0,4 l/min	24-1560-3577
Pump design 250 bar /0,4 l/min with signal monitoring	24-1560-3578
Pump design 250 bar /0,2 l/min	24-1560-3580
Pump design 250 bar /0,2 l/min with signal monitoring	24-1560-3581
<b>Frame</b>	<b>Bestell Nr.</b>
Carrying frame with machine mount	24-1722-2545
Carrying frame with machine mount and carrying handles	24-1722-2550
Chassis with wheels	24-1722-2552
Chassis with wheels and carrying handles	24-1722-2551

The following assembly instructions cover the assembly of all available designs. The customer must follow the assembly steps for the specific design ordered.



### Warning!

To ensure safe and ergonomic operation of the electrical grease feed pump, the minimum clearance as indicated must be observed.

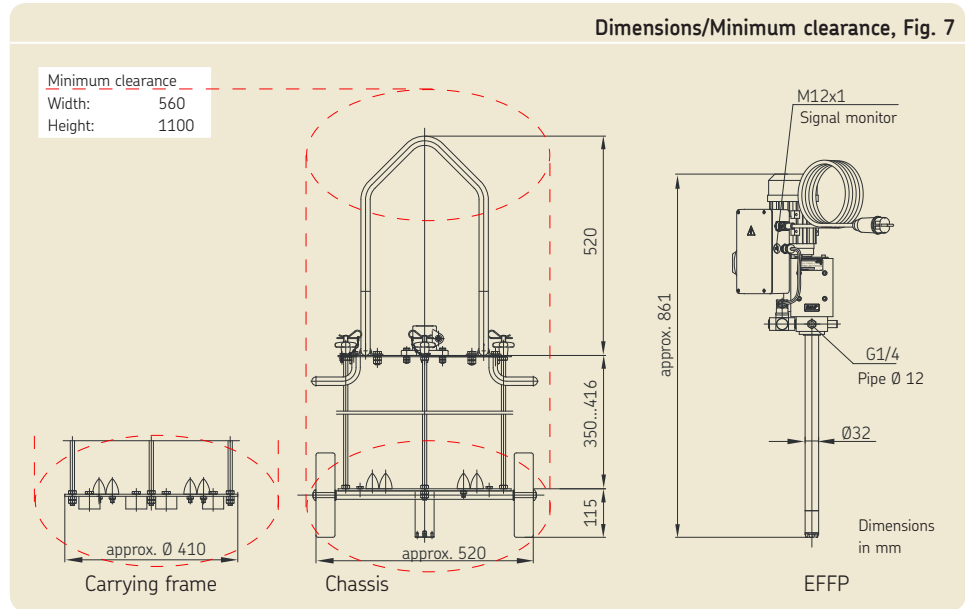

## 5.2 Assembly

### 5.2.1 Installing the EFFP in the upper frame section

- Loosen cotter pins **(1)** (4x) on palm grips **(2)** (4x).
- Loosen the palm grip **(2)** from the tie-rods **(3)** (4x) and unscrew several turns.
- Slightly bend the upper frame section (with lid) **(4)** and remove upper frame section from the tie-rods **(3)** at an angle.
- Loosen the locknuts **(5)** (4x) and place them aside.
- Loosen the hexagon nuts **(6)** (4x) (WAF 13) from the hexagon head bolts **(7)** (WAF 13) and place the bolts and nuts aside.
- Loosen the base clamp **(8)** from the upper frame section **(4)** and insert it into the cylinder liner **(9)** of the electrical grease feed pump **(10)**.
- Diagonally introduce the electrical grease feed pump **(10)** with base clamp **(8)** into the upper frame section **(4)** and align it vertically.
- Align the base clamp **(8)** and screw it in using hexagon head bolts **(7)** (4x) and hexagon nuts **(6)**.
- Fix the hexagon nuts **(6)** using locknuts **(5)**.
- Place the upper frame section **(4)** with the electrical grease feed pump **(10)** aside.

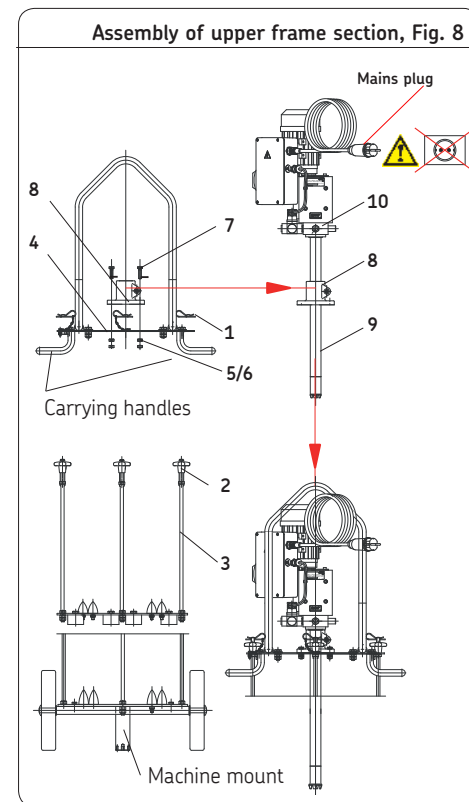

### 5.2.2 Installation of grease pail and grease follower plate

#### Grease follower plate

Internal diameter of grease pail [mm]	kg	Order No.
265 to 285	18/20	24-1952-2034
285 to 305	18/20	24-1952-2035
305 to 350	18/25	24-1952-2036

- On the lower frame section (1) (carrying frame or chassis), gently loosen the hexagon nuts (2) (4x) (WAF 13) of the round rubber springs (3) (4x).
- Move the centering rubber strip (3) (4x) (using the oblong holes in the frame base) to the grease pail and press it gently.
- Place the grease pail (4) in the lower frame section (1) and align the pail centrally with the section.
- Remove the lid from the grease pail (4).
- Insert the grease follower plate (5) into the cylinder liner (6) of the electrical grease feed pump.
- Insert the upper frame section with electrical grease feed pump and grease follower plate (5) into the grease pail (4) and align centrally.
- Introduce the tie-rods (7) into the open oblong holes on the lid of the upper frame section.
- Tighten the palm grips (8) (4x) and secure them using cotter pins (9) (4x).
- Move the centering rubber (3) (4x) (using the oblong holes in the frame base) to the grease pail and press it gently.
- On the lower frame section (carrying frame or chassis) (1), tighten the hexagon nuts (2) (4x) (WAF 13) of the centering rubber strips (3) (4x).

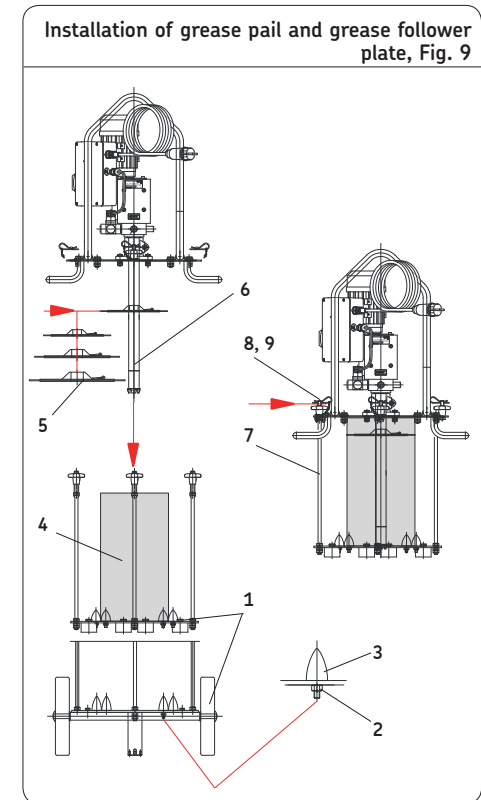

### 5.2.3 Installation of the filling fitting

☞ See Fig. 10

				Filling fitting
Item	Description	max. pressure [bar]	Quantity	Order No.
1	High-pressure hose, optional:			
	High-pressure hose, DN 12, length 3 m	160	1	24-1868-4329
	High-pressure hose, DN 12, length 6.5 m	160	1	24-1868-3429
	High-pressure hose, DN 12, length 10 m	160	1	24-1868-4330
	High-pressure hose, DN 12, length 5 m	275	1	24-1868-4334
	High-pressure hose, DN 12, length 10 m	275	1	24-1868-4335
	High-pressure hose, DN 12, length 15 m	275	1	24-1868-4336
2	Screw union G1/4		2	412-423W
3	Washer for screw union		2	DIN 7603-A14x18-CU
4	Coupling socket G1/4		1	995-001-500
5	Coupler plug for customer equipment G1/4		1	995-000-705
6	Grease gun G1/4		1	169-000-031
7	Grease gun G1/4 with volumetric meter		1	24-0455-2902

- Screw the high-pressure hose **(1)** into the electrical grease feed pump using the screw union **(2)** and washer **(3)**.
- Tighten the high-pressure hose **(1)**.
- On the free end of the high-pressure hose **(1)**, screw in the grease gun **(6 or 7)** or coupling socket **(4)** using another screw union **(2)** and washer **(3)**.
- Fasten the grease gun **(6 or 7)** or coupling socket **(4)** finger-tight.

## 6. Operation

### 6.1 General information



#### Warning!

Prior to commissioning, the voltage specifications of the EFP electrical grease feed pump (motor rating plate) must be checked against the local electrical operating conditions and local regulations. **If there are any discrepancies, the EFP may not be put into operation.**



Observe the instructions from the machine manufacturer regarding the lubricants that are to be used.

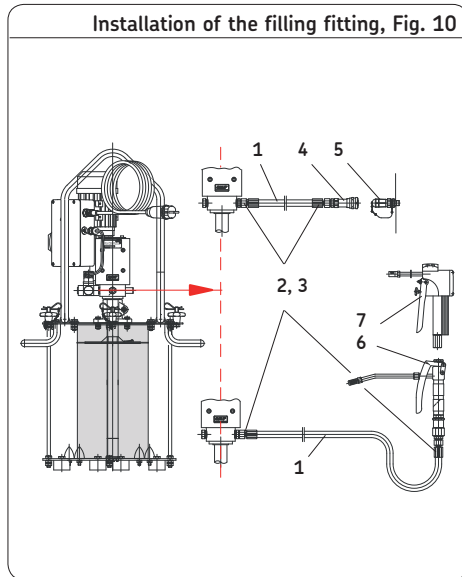

#### Motor key data

		Pump design	
		100 bar	250 bar
Motor output		0,18 kW	0,37 kW
Operating voltage	1 x 230 V; 50 Hz (with running capacitor)		
Intake current, max.		1,6 A	2,73 A
Motor speed		1390 U/min	1320 U/min
Gearbox output speed	66 U/min		
Insulation class/protection class	F / IP54		



### Warning!

Observe the max. mark on the pump that will be filled.

Do not overfill under any circumstances! If the pressure-limiting valve is missing, there is a risk of the pump reservoir breaking.

The described product functions automatically. The lubricant transport should, however, be subjected to regular visual inspection.

The lubricant fill level in the lubricant reservoir should likewise be subjected to regular visual inspection. If the lubricant fill level is too low, lubricant needs to be added up to the maximum mark or the grease pail needs to be replaced.



### Warning!

Only fill using clean lubricant and an appropriate device. Contaminated lubricants can result in severe system malfunction.

## 6.2 Note on the rating plate

The rating plate on the pump unit provides important data such as the order number, barcode, operating voltage, and serial number. To avoid loss of this data in case the rating plate becomes illegible, these characteristics should be entered in the following table.

- Enter key data from rating plate in the following table.

<input type="text"/>	Order number
<input type="text"/>	Typ
<input type="text"/>	Power supply
<input type="text"/>	Serial number

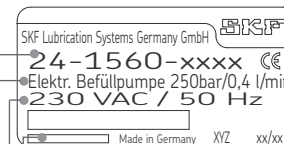



### 6.3 Commissioning



See safety instructions in Chapter 1.1.

- Check the voltage specifications and motor rating plate/local electrical operating conditions.
- Connect the power supply (1) (insert plug into socket outlet).

#### Vent the electrical grease feed pump. using grease gun:

- Switch the ON/OFF switch (2) to ON.
- Actuate the grease gun (3) until grease without bubbles discharges.

#### using coupling socket G1/4:

- Remove the coupler plug provided by the customer (4) from the pump and insert it into the coupling socket (5) of the filling hose (6).
- Switch the ON/OFF switch (2) to ON and let the pump run until grease without bubbles

discharges from the coupler plug.

- Remove the coupler plug provided by the customer (4) from the coupling socket (5).
  - Screw the coupler plug provided by the customer (4) into the pump and fasten it finger-tight.
  - Fill pump to maximum fill level.
  - After filling is complete, remove the mains connection and rewind cable and hose onto handle.
- ☞ The fill level of the grease pail can be visually inspected through the holes in the lid (by viewing the grease follower plate).



Do not let the EFFF run until empty; change the grease pail in advance. If the EFFF has been emptied, it must be vented again.

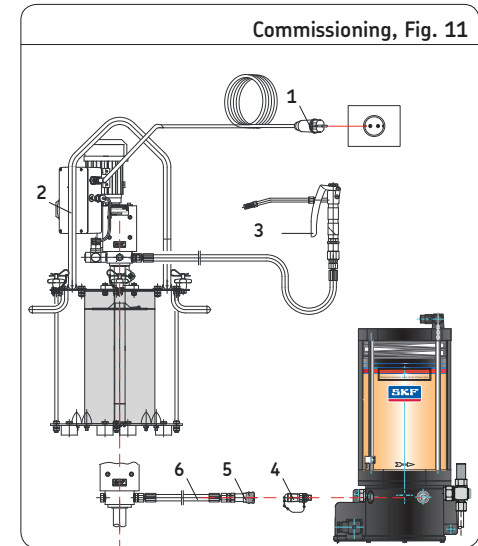

## 6.4 Grease reservoir replacement

- Loosen cotter pins **(1)** (4x) from the tie-rods **(3)** (4x).
- Loosen the palm grips **(2)** from the tie-rods **(3)** (4x) and unscrew several turns.
- Slightly bend the upper frame section **(4)** with the electrical grease feed pump and empty grease pail then remove the upper frame section from the tie-rods **(3)** at an angle.
- Place the upper frame section with the electrical grease feed pump aside.
- Remove the grease follower plate **(6)** from the empty grease pail **(5)** and insert it into the cylinder liner **(7)** of the electrical grease feed pump.
- Remove the empty grease pail **(5)** from the lower frame section **(8)**, insert the new grease pail **(9)** and align centrally.
- Remove the lid from the new grease pail.
- Insert the upper frame section **(4)** with electrical grease feed pump and grease follower plate **(6)** into the grease pail **(9)** and align centrally.
- Introduce the tie-rods **(3)** into the open oblong holes on the lid of the upper frame section.
- Tighten the palm grips **(2)** (4x) and secure them using cotter pins **(1)** (4x).
- Vent the electrical grease feed pump as described in Chapter 6.3.

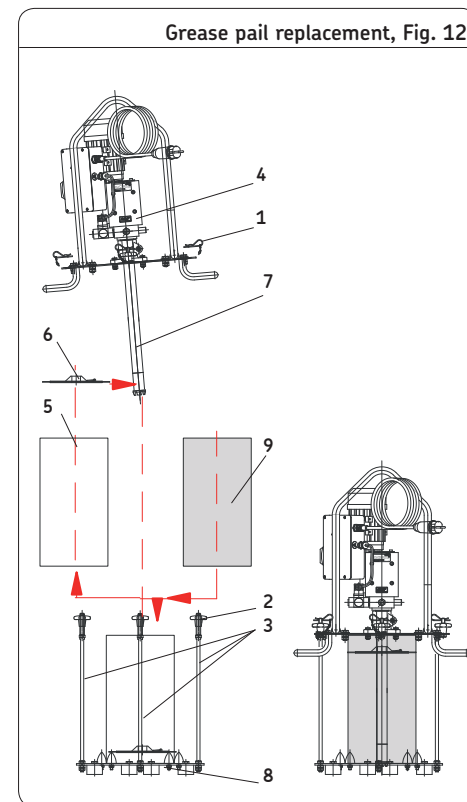

### 6.5 Signal input device for external filling level monitoring

For pump designs with signal input must the external filling level monitoring on the M12x1 connector of the signal output be mounted.

If the external filling level monitoring is not required, please put the crossporting connector in place.

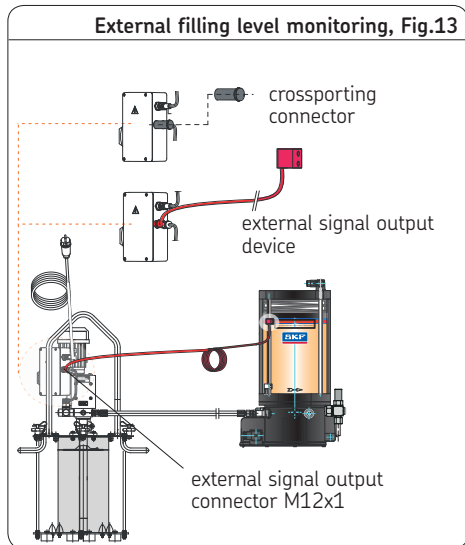

## 7. Shutdown and disposal

### 7.1 Temporary shutdown

The described product can be shut down temporarily by disconnecting the electrical supply connection (disconnecting the mains plug).

If the product will be shut down for an extended period of time, the instructions in Chapter 3, "Transport and storage," must be observed.

To recommission the product, follow the safety instructions in Chapter 1 as well as Chapter 6.3, "Commissioning, venting."

### 7.2 Permanent shutdown

If the product will be permanently shut down, the local regulations and laws regarding the disposal of contaminated equipment must be observed.



#### Warning!

Lubricants can contaminate soil and bodies of water. Lubricants must be properly used and disposed of. Observe the local regulations and laws regarding the disposal of lubricants.

The product can also be returned to SKF Lubrication Systems Germany GmbH for disposal, in which case the customer is responsible for reimbursing the costs incurred.

The parts are recyclable.

## 8. Maintenance

### 8.1 General information



See safety instructions in Chapter 1.1.



#### **Danger!**

Performing work on an energized pump or product may result in serious injury or death. Assembly, maintenance and repair work may only be performed on products that have been de-energized by qualified technical personnel. Supply voltage must be switched off before opening any of the product's components.

Products from SKF Lubrication Systems are low-maintenance. However, all connections and fittings must be regularly inspected for proper seating to ensure proper function and to prevent hazards from arising.

If necessary, the product can be cleaned using mild cleaning agents that are compatible with the product's materials (non-alkaline, non-soap).

For safety reasons, the product must be disconnected from the power supply and the hydraulic connection.

Do not allow any cleaning agent to enter the interior of the product during cleaning.

It is not necessary to clean the interior of the product if the product is operated normally and incompatible lubricants are used.

The interior of the product must be cleaned if incorrect or contaminated lubricant is accidentally filled into the product. If this occurs, please contact the Service department of SKF Lubrication Systems for assistance.



Dismantling of the product or individual parts thereof within the statutory warranty period is not permitted and voids any claims.



Only original spare parts from SKF Lubrication Systems may be used. Unauthorized alterations to products and the use of non-original spare parts and accessories are prohibited and nullify the statutory warranty.

SKF Lubrication Systems shall not be responsible for any damages resulting from improper assembly, maintenance, or repair work on the product.

The electrical grease feed pump functions without maintenance in principle. In order to prevent air intake, ensure that the grease level does not fall below the cylinder liner's intake hole.

## 8.2 Visual inspection

The maintenance intervals depend on how long the electrical grease feed pump has been operated. The customer is therefore responsible for determining and observing these on its own.

The operator/operating personnel must perform a visual inspection of the complete EFP (see Chapter 8.2) at regular intervals. SKF recommends an inspection every 48 operating hours.

If the EFP has been run empty, the pump must be vented as described in Chapter 6.3 after filling.

 The purity of the lubricants used is the decisive factor in the service life of the piston pump.

### Visual inspection every 48 operating hours

Item	Component	Check
1	Worm gear drive motor	<ul style="list-style-type: none"> <li>Inspect fan slots on fan impeller for contamination</li> <li>Inspect for loosened screw unions.</li> <li>Inspect for undesired grease discharge.</li> <li>Inspect for loose cable connections and damage.</li> </ul>
2 3 4	Handle Tie-rod Cotter pin	<ul style="list-style-type: none"> <li>Inspect fixing nuts every 4 weeks and tighten if necessary.</li> <li>Inspect cotter pins on the tie-rod for correct seating.</li> </ul>
	Complete	<ul style="list-style-type: none"> <li>Regularly inspect pump components for leaks.</li> <li>Inspect electrical cables for damage.</li> </ul>

Maintenance items Fig. 14

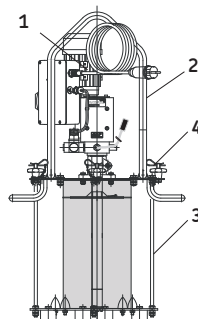

## 8.3 Service

If you encounter problems or have any questions, please contact our sales and service centers or our representatives abroad. A list with current addresses is available on the Internet at:

[www.skf.com/lubrication](http://www.skf.com/lubrication)

## 9. Malfunctions, causes, and remedies



### Warning!

- See safety instructions in Chapter 1.
- In cases of functional failure, always make sure that all technical specifications have been complied with in the existing operating conditions.
- The grease supply pump has an ON/OFF switch with integrated thermal protection (see page 15, chapter 4.1, Position 1.2), which responds in case of a pump blockage. Only after elimination of the blockage and cooling down of the motor the grease supply pump may be put into operation again.

Malfunction	Cause	Remedy
Displacement volume and/or delivery pressure too low	<ul style="list-style-type: none"> <li>○ Grease follower plate does not follow</li> <li>○ Pressure regulating valve is defective</li> <li>○ Air in the electrical grease feed pump</li> <li>○ Grease flow pressure is above 700 mbar</li> <li>○ Pump shaft speed is too low</li>   <li>○ Intake area on pump screw piece (4) (see page 17) is clogged or contaminated with foreign substances</li> </ul>	<ul style="list-style-type: none"> <li>• Check positioning, replace if necessary</li> <li>• Replace pressure regulating valve</li> <li>• Vent as described in Chapter 6.3</li> <li>• Replace grease pail, reduce flow pressure</li> <li>• Check electrical connections</li> <li>• Replace geared motor if necessary</li> <li>• Clean screw piece (4), replace if necessary</li> </ul>
No delivery	<ul style="list-style-type: none"> <li>○ Air in the electrical grease feed pump</li> <li>○ Empty grease pail</li> <li>○ Drive motor does not run</li> </ul>	<ul style="list-style-type: none"> <li>• Vent as described in Chapter 6.3</li> <li>• Replace and vent grease pail</li> <li>• Check electrical connections</li> <li>• Clean geared motor</li> <li>• Replace geared motor if necessary</li> <li>• Actuate circuit breaker on terminal box</li> </ul>
	<ul style="list-style-type: none"> <li>○ crossporting connector or external signal input (see chapter 6.5) not connected</li> </ul>	<ul style="list-style-type: none"> <li>• Check connection, if necessary again pull</li> </ul>

## 10. Technical data

### Electrical grease feed pump

Characteristics, table 1 of 2

		Pump design	
		100 bar	250 bar
<b>General</b>			
Mounting position	vertical		
Temperature range	-10 °C to + 60 °C		
or grease pail für Fettfolgeteller	16 kg to 25 kg 265 mm to 285 mm 285 mm to 305 mm 305 mm to 350 mm		
Internal dimensions of drum	347 to 413 mm		
Dry weight of basic design			
Carrying frame with grease follower plate (without grease pail)		32,5 kg	34,5 kg
Dry weight of chassis with grease follower plate (without grease pail)	36 kg		
Carrying handles	0,8 kg		
<b>Motor</b>			
System voltage	230 V AC, 50 Hz		
See "Motor ratings" table in Chapter 6.1 and rating plate			
Power consumption, max.		1,6 A	2,73 A
Protection class	IP54		
Insulation class	F		

Characteristics, table 2 of 2

		Pump design	
		100 bar	250 bar
<b>Pump</b>			
Type	Piston pump, 1 outlet		
Operating pressure			
Automatic switch-off		100 bar	250 bar
Pressure regulating valve			
et to		120 bar	300 bar
<b>Displacement</b>	Depends on lubricant, approx. 400 cm <sup>3</sup> /min at 20 °C with SKF LGWM 2/18 <sup>1)</sup>		
Flow pressure, max.		700 mbar	
<b>Approved lubricants</b>			
	greases based on mineral oil as well as environmentally friendly and synthetic oils and greases		

1) Changes in temperature and lubricant may significantly affect the delivery rate.

## 11. Spare parts



### Warning!

Alteration or modification of the EFPF is only permitted with manufacturer's agreement (see page 2). Original spare parts and accessories authorized by the manufacturer serve to ensure safety. The use of other parts shall eliminate any liability for consequences thereof.

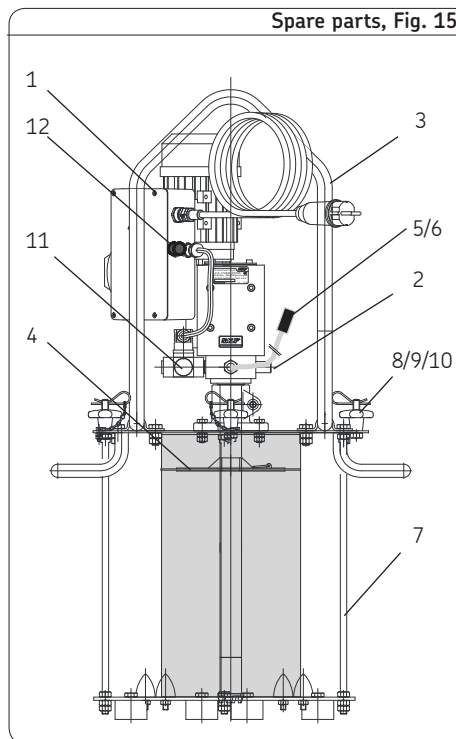



## 11. Spare parts

### Spare parts

Item	Pump design	Description	Material Nr.
1	100 bar	Geared motor, terminal box, complete with cable	24-6882-0065
		Geared motor, terminal box, signal monitor, complete with cable	24-6882-0067
	250 bar	Geared motor, terminal box, complete with cable	24-6882-0066
		Geared motor, terminal box, signal monitor, complete with cable	24-6882-0068
2	100 bar	Pressure regulating valve 120 bar, (without spacer sleeve) Spacer sleeve	995-001-887 827-200-006
	250 bar	Pressure regulating valve 300 bar, (without spacer sleeve) Spacer sleeve	995-001-885 827-200-006
3		Handle (without mounting clips)	44-1751-2869
4		Grease follower plate	<i>see pages 21/34</i>
5		High-pressure hose	<i>see pages 22/34</i>
6		Coupling socket	<i>siehe Seite 22/Seite 34</i>
7		Tie-rod	44-0717-2322
8		Palm grip	95-2051-6335
9		Chandelier chain (without KFU2.26 ring)	996-000-214
10		Cotter pin	95-0025-11024
11	100 bar	Automatic shut-off/pressure switch	DSB1-S10000X-1A-01
	250 bar	Automatic shut-off/pressure switch	DSB1-S25000X-1A-01
12		Crossporting connector	179-990-863

## 12. Accessories

 Only use accessories approved by SKF.

### Accessories

Item	Description	Part No.
1	<b>Grease follower plate</b> for grease pail with internal diameter of	
	265 to 285 mm (capacity 18/20 kg)	24-1952-2034
	285 to 305 mm (capacity 18/20 kg)	24-1952-2035
	305 to 350 mm (capacity 25 kg)	24-1952-2036
2	<b>High-pressure hose</b> nominal diameter 12 mm M18x1.5	
	Max. pressure 160 bar, length 3 m	24-1868-4329
	Max. pressure 160 bar, length 6.5 m	24-1868-3429
	Max. pressure 160 bar, length 10 m	24-1868-4330
	Max. pressure 275 bar, length 5 m	24-1868-4334
	Max. pressure 275 bar, length 10 m	24-1868-4335
	Max. pressure 275 bar, length 15 m	24-1868-4336
3	<b>Screw union</b> G1/4	412-423W
4	<b>Copper washer</b> for screw union G1/4	DIN7603-A14x18-CU
5	<b>Coupling socket</b> G1/4 high-pressure hose	995-001-500
6	<b>Coupler plug</b> G1/4 (customer application)	995-000-705
7	<b>Grease gun</b> G1/4	169-000-031
8	<b>Grease gun</b> G1/4 with volumetric meter	24-0455-2902
9	<b>Handle kit</b> for installation by customer	24-0204-0001
10	<b>Wheelset</b> for installation by customer	24-1709-2018

Accessories, Fig. 16

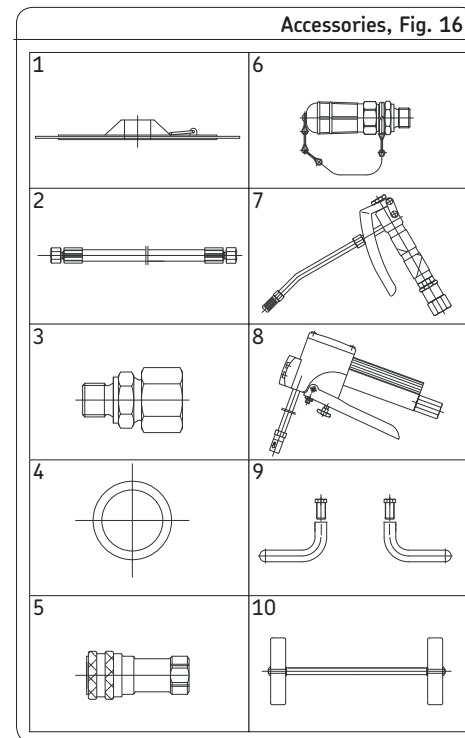



## 951-180-061-EN

The contents of this publication are the copyright of the publisher and may not be reproduced in whole or in part without permission of SKF Lubrication Systems Germany GmbH. Every care has been taken to ensure the accuracy of the information contained in this publication. but no liability can be accepted for any loss or damage whether direct, indirect or consequential, arising out of use of the information contained herein. All SKF products may be used only for their intended purpose as described in these operating instructions with associated operating instructions. If assembly/operating instructions are supplied together with the products, they must be read and followed. Not all lubricants can be fed using centralized lubrication systems. SKF can, on request, inspect the suitability of the lubricant selected by the user for pumping in centralized lubrication systems. Lubrication systems and their components manufactured by SKF are not approved for use in conjunction with gases, liquefied gases, pressurized gases in solution, vapors, or such fluids whose vapor pressure exceeds normal atmospheric pressure (1013 mbar) by more than 0.5 bar at their maximum permissible temperature.

Hazardous materials of any kind, especially the materials classified as hazardous by CLP Regulation EC 1272/2008 may only be used to fill SKF centralized lubrication systems and components and delivered and/or distributed with the same after consulting with and receiving written approval from SKF.

SKF Lubrication Systems Germany GmbH  
Motzener Strasse 35/37 · 12277 Berlin · Germany  
PO Box 970444 · 12704 Berlin · Germany  
Tel. +49 (0)30 72002-0 · Fax +49 (0)30 72002-111  
[www.skf.com/lubrication](http://www.skf.com/lubrication)

SKF Lubrication Systems Germany GmbH  
2. Industriestrasse 4 · 68766 Hockenheim · Germany  
Tel. +49 (0)62 05 27-0 · Fax +49 (0)62 05 27-101  
[www.skf.com/lubrication](http://www.skf.com/lubrication)

