



MRC Bearing Services

Bearings for Machine Tools

Bearings for Machine Tools

MRC

Table of Contents

	<i>Page</i>
Section I—Introduction	3
Custom Made-To-Order (MTO) Capabilities	5
Disclaimer	5
Warranty Statement	5
Section II—Precision Bearings for Machine Tool Spindles	7
Selection of Bearing Type	9
Application Requirements	9
Spindle Bearing Arrangements	10
Section III—Precision Angular Contact Ball Bearings	15
Matched Bearing Sets	17
Speed Ratings	18
Cages	19
Hybrid Bearings	19
Preload	20
Mounting Fits	23
Tolerances	24
Equivalent Dynamic and Static Radial Loads	25
Load Ratings for Bearing Sets	25
Bearing Specification Tables	29
15° Angular Contact Ball Bearings Type R	29
25° Angular Contact Ball Bearings 7000 Series	33
Ex-Cell-O Spindle Bearings	36
Section IV—Precision Double Row Cylindrical Roller Bearings with Tapered Bore	39
Tolerances	41
Cages	41
Internal Clearance	41
Adjustment of Clearance or Preload	42
Specification Tables—NN3100X Series	45
Section V—Single Direction Ball Screw Support Bearings	47
Universal Mounting	49
Cages	49
Speed Ratings	49
Tolerances	49
Preload	50
Axial Stiffness	50
Friction Torque	50
Equivalent Dynamic and Static Radial Loads	52
Bearing Mounting Arrangement	53
Accuracy of Associated Components	54
Lubrication	54
Specification Tables—J Series	55
Section VI—Double Direction Thrust Ball Bearings	59
Tolerances	61
Preload	62
Cages	62
Equivalent Dynamic and Static Radial Loads	63

Mounting Instructions	63
Specification Tables—DT100 Series	64
Section VII—Precision Ground Ball Screws	67
Recommendations for Selection	69
Dynamic and Static Load Ratings	69
Nominal Fatigue Life (L10) and Service Life	69
Speed Limits	70
Efficiency	70
Axial Play and Preload	70
Axial Stiffness	71
Recommended Assembly Procedure	72
Lead Precision	73
Specification Tables	74
Flanged Nut with Internal Preload-PGFJ Series	74
Double Preloaded Flanged Nut—PGFL Series	76
Double Preloaded Flanged Nut—PGFE Series	80
Cylindrical Double Preloaded Nut—PGCL Series	82
Standard Machined Ends	86
End Bearings with Flanged Housing—FLBU Series	90
End Bearings with Fixed Plummer Housing—PLBU Series	93
End Bearings with Free Plummer Housing—BUF Series	96
Calculation Formulae	99
Section VIII—Profile Rail Guides	103
Product Review	104
Accuracy Classes	106
Mounting Accuracy	109
Preload and Stiffness	111
Specification Tables	116
High Performance Rail Guides	116
LLBHS—TA	116
LLBHS—TB	118
LLBHS—TR	120
Heavy Duty Rail Guides	124
LLBHS—A/LA	124
LLBHS—B/LB	126
LLBHS—R/LR	128
Bellows	130
Compact and Medium Load Rail Guides	131
LLBUS—R/SR	132
LLBNS—TR	134
M Type Rail Guides	140
M—TC	140
M—TW	140
Miniature Profile Rail Guides	144
LLMHS—TA	145
LLMHS—LA	145
Accessories—Lubrication Plate	148
LLBHA—G	148
Section IX	151
Product Interchange	154
Product Index	170

Introduction

Section I



MRC Bearing Services can provide bearings with non-standard characteristics to meet application requirements, by modifying a stock bearing or designing and manufacturing a new bearing through MTO Products. All modifications and new designs carry the MRC manufacturer's warranty.

Bearing Types

- 15° angular contact R type
- 25° angular contact 7000 series
- Double-row cylindrical roller bearings
- Ball screw support bearings

Available Variations:

- **Duplex Grinding**—matching bearing sets to produce axial preload or clearance (to increase rigidity or account for growth)
- **Bore Grinding**—increasing bore diameter
- **Outer Diameter Modification**—removing material from OD to reduce the outer diameter, machining slots, grooves, lubrication holes, or a spherical crown
- **Tapered Bore**—machining standard cylindrical bore to a tapered bore
- **Width Grinding**—reducing bearing width to custom dimensions, flush grinding, etc.
- **Cages**—changing existing cages to other materials: brass, phenolic (bakelite), polyamide (nylon)
- **Lubrication**—providing pre-greased bearings or special preservatives
- **Material**—offering bearing components in standard 52100 steel, 440C stainless steel, M50 tool steel, silicon nitride (ceramic)
- **Coatings**—applying thin dense chrome, silver, cadmium, black oxide or phosphate to bearing surfaces
- **Heat Treatment**—dimensional stabilization of bearing components for extreme temperature operation
- **Identification**—special marking on bearings and packaging
- **Packaging**—re-wrapping single or bulk, and/or reboxing bearings

Disclaimer

The contents of this catalog are the copyright of the publishers and may not be reproduced (even extracts) unless permission is granted. Every care has been taken to ensure the accuracy of the information contained in this catalog but no liability can be accepted for any errors or omissions.

Listing in this catalog does not necessarily imply product availability.

The designs and load ratings shown in this catalog are those being used at the time of publication.

Interchange Information

Interchanges provided in this catalog can provide a fast conversion of manufacturer numbers to MRC equivalents. Please note that interchanges are made on an application basis and may not be completely identical to MRC Bearing Services products. Basic interchanges indicate overall compatible design. The interchange information was compiled using data available at the time of publication; however, SKF USA Inc. and MRC Bearing Services assume no responsibility or liability for errors or omissions.

Warranty

MRC Bearing Services warrants that products sold by it shall be free from defects in material and workmanship. MRC Bearing Services' obligation under this warranty is expressly limited to furnishing without additional charge a replacement, or at its option, repairing or issuing credit for any product which shall within one year from the date of sale be returned freight prepaid to the plant designated by an MRC Bearing Services representative and which upon inspection is determined by MRC Bearing Services to be defective in materials or workmanship. Complete information as to service, mounting and relubrication should accompany any product returned for inspection. The provisions of this warranty shall not apply to any

MRC Bearing Services product which has been subjected to misuse, improper mounting, assembly or lubrication; or which has been repaired or altered if such repair or alteration in the judgement of MRC Bearing Services would adversely affect performance of the product.

This warranty is in lieu of all other warranties, expressed or implied, including any limited warranty of merchantability or fitness for a particular purpose and is also in lieu of all other obligations or liabilities on the part of MRC Bearing Services, including any

obligation or liability arising from contract, tort or otherwise for damages and in no event shall seller be liable hereunder or otherwise for loss of profits; special, incidental, or consequential damages of any kind. There are no warranties, expressed or implied, made by MRC Bearing Services, except the warranty against defects in material and workmanship set forth above. MRC Bearing Services and SKF USA Inc. neither assume nor authorize any other person or firm to assume for it any other obligation or liability in connection with its products.

Precision Bearings for Machine Tool Spindles

Section II

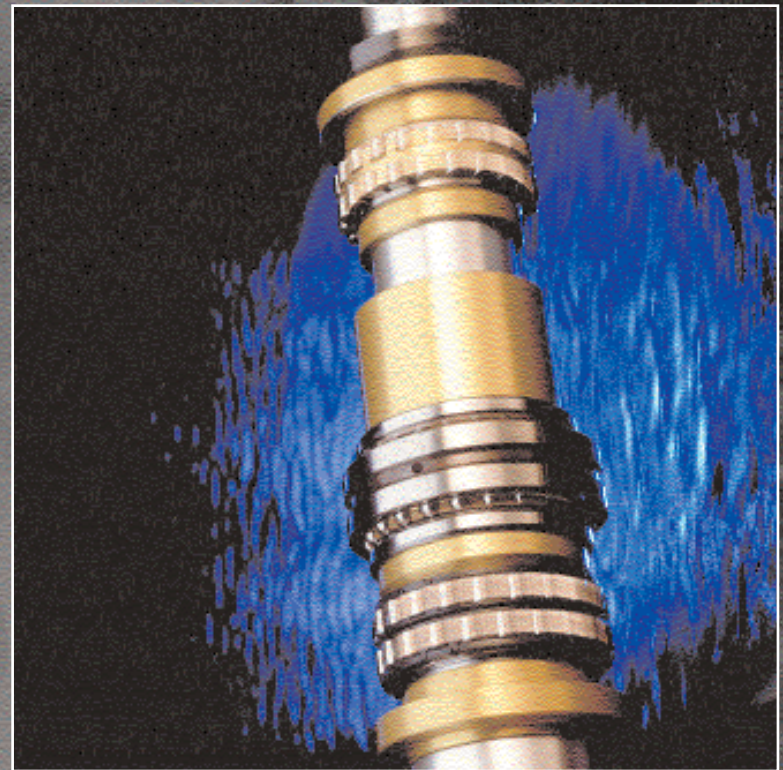

Bearings for the demanding requirements that exist in high precision machine tool applications must have high running accuracy and stiffness, as well as low friction if desired machining accuracy is to be obtained with the lowest possible operating temperature. Each of the various bearing types shown in this catalog have characteristics that make them especially suitable for a particular application.

Selection of Bearing Type

When designing a precision bearing arrangement the following factors must be considered; for example:

- Accuracy
- Available space
- Loads
- Stiffness
- Allowing for axial displacement (floating)
- Speed
- Heat generation

Accuracy

The running accuracy of a bearing arrangement is governed by the accuracy of all the component parts of the arrangement. Where the bearings are concerned it is primarily determined by the accuracy of form and position of the raceways on the bearing rings. When selecting the appropriate tolerance class for a particular bearing, the maximum radial runout of the inner ring is generally the determining factor for most applications.

Radial runout and other tolerances are found on page 24.

Available Space

Precision bearing arrangements generally call for bearings with a low cross section because of the limited space available and the high requirements in respect of stiffness and running accuracy of the arrangement. These bearings, generally, have a large number of small-diameter rolling elements and consequently have a high stiffness. They also enable relatively large diameter spindles to be used for a given housing bore diameter and therefore exhibit all the advantages which are important for both the stiffness and the running accuracy of the bearing arrangement. It is thus possible, by selecting a suitable combination of bearings, to achieve an optimum bearing arrangement for particular requirements within the same radial space.

Loads

In machine tools, the main application for precision bearings—the load carrying capacity of a bearing—is generally much less important when determining bearing size than in general engineering applications. Other criteria such as stiffness, size of the required bore in the spindle, machining speeds and accuracy are the decisive factors.

When selecting the type of bearing for a given bearing arrangement, however, the magnitude as well as the direction of action of the load play an important part. As a general rule, roller bearings can carry heavier loads than ball bearings having the same envelope dimensions. Angular contact ball bearings, which have their raceways arranged at an angle to the bearing axis, are more appropriate for the accommodation of combined loads or purely axial loads.

Stiffness

The stiffness of a bearing, characterized by the magnitude of the elastic deformation of the bearing under load, is of particular importance where highly accurate bearing arrangements are required. Roller bearings are stiffer than ball bearings because of the contact conditions between the rolling elements and raceways. Stiffness can be enhanced by preloading the bearing.

Axial Displacement

Cylindrical roller bearings are particularly suitable as non-locating bearings. Axial displacements in both directions can be accommodated between the rollers and the raceway of one of the rings. Both inner and outer ring can therefore be mounted with an interference fit.

If sets of angular contact ball bearings are used as the non-locating (floating) bearings, the housing fit must be loose to allow axial displacement. However, this has a negative influence on the stiffness of the bearing arrangement system.

Speed

The speed at which a rolling bearing can operate is governed largely by the permissible operating temperature. Bearing types with low friction, and thus low heat generation within the bearing, are therefore the most suitable for high speed operation.

Heat Generation

The heat generated in a bearing arrangement is of considerable importance for the operating conditions and performance of a machine. It is largely determined by the operating speed, but also depends on the bearing type, the method of lubrication, the degree of bearing preload and the load conditions.

As bearing type, operating speed and load are generally fixed for a given bearing arrangement; the method of lubrication and the quantity of lubricant are decisive with respect to heat generation.

Spindle Bearing Arrangements

The most important factors which have to be considered when designing bearing arrangements for machine tool spindles, as already mentioned, are the stiffness, the running accuracy, the speed and the operating temperature.

In order to satisfy these partly conflicting demands, precision bearings of widely differing designs are used.

Examples of typical mounting arrangements and operating characteristics are shown on the following page.

Application of Bearings

Spindle Bearing Arrangement 1

In this arrangement, which has a particularly high load carrying capacity, the cutting and feed forces, i.e. the radial and axial loads, are taken up by separate bearings. The arrangement is particularly stiff in both radial and ax-

ial directions. The running accuracy is very high. The cylindrical roller bearing at the drive side permits changes in spindle length to be accommodated.

Spindle Bearing Arrangement 2

This arrangement is recommended for spindles which are to operate at speeds that are too high for arrangement 1. However, the increased speed capability is obtained at the expense of stiffness. Running accuracy is comparable with that of arrangement 1. Where high stiffness and load carrying capacity in the axial direction are needed, angular contact ball bearings with a contact angle of 25° are preferred.





Spindle Bearing Arrangement 3

This arrangement is recommended for high-speed spindles. Its stiffness is lower than for the arrangements so far described, but is generally adequate when speeds are high and cutting forces small.

If the axial load acts in one direction only, the bearing pairs at the spindle ends can be arranged in tandem. In this case, the required preload must be applied using springs, and the stiffness is then somewhat higher.

Spindle Bearing Arrangement 4

This arrangement is suitable for exceptionally high speeds. If the axial loads are larger than those for which the bearings with a 15° contact angle are designed, bearings with a contact angle of 25° should be used.

Bearing Combination		Characteristics			
Work side	Opposite Side	Speed Capability	Running Accuracy	Stiffness	Dynamic Load Carrying Capacity
Spindle bearing arrangement 1					
		moderate	very high	extremely high	extremely high
Double row cylindrical roller bearing with double direction angular contact thrust ball bearing	Double row cylindrical roller bearing				
Spindle bearing arrangement 2					
		high	very high	very high	very high
3 angular contact ball bearings in a tandem/back-to-back arrangement	Double row cylindrical roller bearing				
Spindle bearing arrangement 3					
		very high	very high	high	high
2 angular contact ball bearings arranged back-to-back at each side					
Spindle bearing arrangement 4					
		extremely high	very high	low	low
1 angular contact ball bearing at each side (back-to-back)					

Typical Mountings

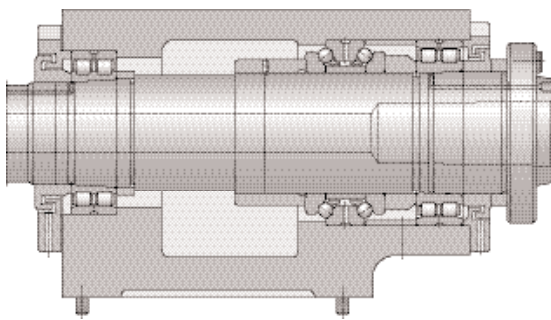

Two NN31X cylindrical roller bearings and one double direction DT100 series thrust bearing.

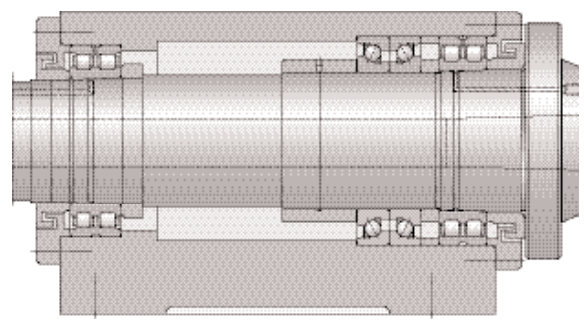

Two NN31X cylindrical roller bearings and one pair 7100 KRDS angular contact ball bearings.

Notes

Precision Angular Contact Ball Bearings

Section III



To meet the various demands with regard to running accuracy, speed capability, stiffness as well as load carrying capacity placed on precision bearing arrangements in an optimum manner, two different types of single row angular contact ball bearings are available from MRC:

- precision angular contact ball bearings
- hybrid precision angular contact ball bearings (with ceramic balls)

MRC precision angular contact ball bearings are non-separable and are essentially single row angular contact ball bearings. In all such bearings the load is transmitted from one raceway to another at an angle to the bearing axis. These bearings can therefore carry axial loads acting in one direction in addition to radial loads. Axial forces produced in the bearing when subjected to a radial load must be counteracted by an opposing force applied externally. The bearings are therefore adjusted against a second bearing.

The internal design of MRC precision angular contact ball bearings differs appreciably from that of standard single row bearings and reflects the latest state of the art where machine tool bearings are concerned. Only one flange on one ring has reduced height; the contact angles are small, and lightweight one-piece cages with a large number of balls are incorporated.

To meet the requirements of modern machine tool applications as fully as possible, MRC precision angular contact ball bearings are made in several series and designs. They are supplied in matched bearing sets. Bearing sets are used when the load carrying capacity of a single bearing is inadequate, or if axial loads acting in both directions have to be accommodated.

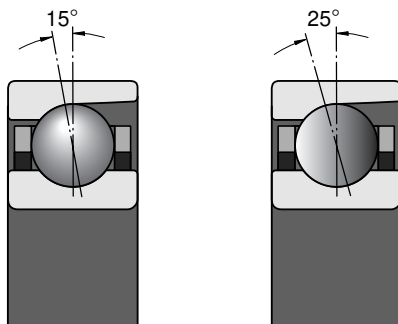

Precision Angular Contact Ball Bearings

MRC precision angular contact bearings are designed with either a 15° or 25° contact angle in order to meet specific machine tool spindle application requirements.

The 15° contact angle bearings are available in the 1900RDS, 100KRDS, 200RDS and 300RDS series, and have ample radial and axial load capacity for most applications, and have the ability to operate at very high speeds.

The 25° contact angle bearings are available in the 71900DS, 7100KRDS, and 7200DS series, can carry very high axial loads and provide ample axial stiffness.

All of the precision angular contact bearings shown in this catalog incorporate a light preload (GA). Many of the sizes listed are available from stock. Other sizes and preloads can be furnished upon request.

Matched Bearing Sets

All MRC precision angular contact ball bearings can be supplied as required in complete sets of two, three, four, and five matched bearings.

The bearings of a set are matched in production so that when they are mounted immediately adjacent to each other in the prescribed order, a given preload will be obtained or the load will be evenly distributed. The bore and outside diameters of the bearings of a set differ from each other by half the permissible diameter tolerance.

To facilitate correct mounting, the bearings of a matched set have a “V” marking on their outside cylindrical surface. The prescribed order must be adhered to if the set is to perform properly. The “V” marking also indicates how the set should be mounted in relation to the axial load. The point of the “V” indicates the direction in which the axial load should act on the center ring. Where axial load acts in both directions, the “V” indicates the direction of the greater axial load.

The bearings of a set are supplied in a unit package but are individually packed within the package.

Universal Bearings for Paired Mounting

These “universal” bearings are a special version of the precision bearings and are intended for paired mounting. They are adjusted during manufacture so that they may be mounted immediately adjacent to each other in a back-to-back, face-to-face or tandem arrangement as desired. When arranged back-to-back or face-to-face, the bearings will have a light preload.

Bearings of universal design are identified by the designation suffix DS.

Precision Angular Contact Ball Bearings

When ordering these bearings it should be remembered that the number of bearing pairs required should be stated, not the number of single bearings.

Tolerances

MRC precision angular contact bearings are manufactured to tolerances that meet the dimensional and running accuracy required in machine tool spindle applications. The tolerances are found in the table on page 24.

Each bearing of a matched set is marked, as illustrated in the adjacent figure, with the complete designation of the bearing set (1) and with the same consecutive number (2) on the face of the outer ring. The position of the greatest out-of-round is also marked on the inner and outer ring faces with an asterisk (3), i.e. the marking shows the greatest wall thickness between the base of the raceway groove and the bore or outside diameter surface. In addition, this position is also indicated by the “V” marking on the outer ring, which is always applied at this position. The actual values of the mean deviations from the nominal bore and outside diameters, Δd_m and ΔD_m respectively, are given on the rings and on the package (expressed in μm).

Mounting Bearing Sets

When mounting bearing sets it should be remembered that the positions of greatest out-of-round on the inner rings should be lined up as well as those on the outer rings. As already mentioned, the order indicated by the “V” marking, and the direction should be adhered to.

Bearing arrangements with particularly high running accuracy can be obtained if the bearings are mounted so that the position of greatest out-of-round of the inner ring is opposite to the position of greatest out-of-round of the shaft. In arrangements where the bearing outer rings rotate, the greatest out-of-round of the outer ring should be diametrically opposed to that of the housing bore.

If spacer sleeves are to be mounted between the bearings of a matched set, sufficient accuracy will be obtained if the sleeves between the inner and outer rings have the same width and flat, parallel faces. This can be achieved by machining the sleeves together, e.g. on a lapping machine. It should be remembered that the order of the bearings indicated by the “V” should be maintained even when spacer sleeves are used.

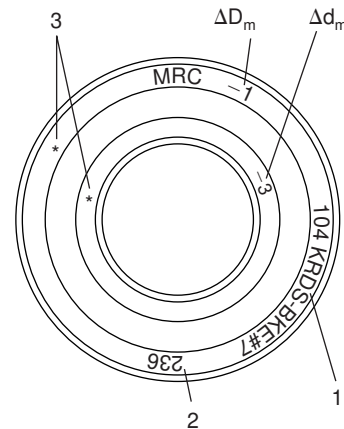
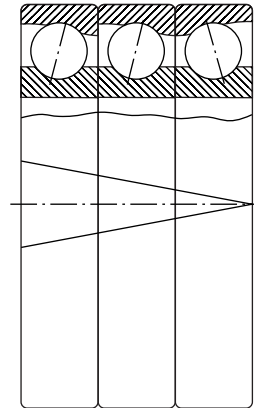

Speed Ratings

The speed ratings quoted in the bearing tables are guideline values and are valid provided that the bearings are lightly loaded ($P \leq 0.06 C$), are lightly preloaded by means of springs, and that good heat dissipation exists.

The values under oil lubrication are maximum values and should be reduced for certain other methods of oil lubrication. The values under grease lubrication are maximum values which can be attained using a good quality grease of soft consistency.

If single bearings have to be adjusted against each other to a greater degree to increase spindle stiffness, or if matched sets of two, three, four or five bearings are to be used, the limiting speed values given in the tables must be reduced. Reduction factors to obtain guideline values for the appropriate conditions are given in the table on page 19. The limiting speeds quoted in the bearing tables should be multiplied by these factors as appropriate.

If the limiting speeds, from the table below, for matched bearing sets are inadequate, a simple design change—the inclusion of intermediate rings between the bearings—will allow appreciable increases to be made. For sets of three bearings, for example, it should then be possible to run at the limiting speeds for paired bearings. Springs to preload the bearings may be beneficial. This type of preload is generally used for high speed operation in order to obtain an even preload over the whole operating range of the machine.

Reduction Factors for Limiting Speeds			
Bearing Arrangement	Reduction Factor		
	Preload		
	Light	Medium	Heavy
Set of two bearings arranged in tandem	0.90	0.80	0.65
Sets of two bearings arranged back-to-back	0.80	0.70	0.55
Sets of three bearings	0.70	0.55	0.35
Sets of four bearings	0.65	0.45	0.25
Sets of five bearings	0.60	0.40	0.20

Cages

All MRC precision angular contact ball bearings are fitted with an outer ring centered cage of fabric reinforced phenolic resin. The cages are of a particularly light-weight design in order to keep centrifugal force at a minimum, and are designed to allow free passage of lubricant to the ball/raceway contacts.

Suffix Designations

MRC precision angular contact ball bearings are identified by the basic size number followed by the suffixes DS, BKE and #7, as shown in the bearing tables.

- DS a duplex single bearing having a light preload as standard.
- BKE an outer ring centered fabric reinforced phenolic resin cage also known as bake, or bakelite.
- #7 ABEC 7 tolerance grade.

Hybrid Precision Angular Contact Ball Bearings

MRC hybrid precision angular contact ball bearings are identical in design to precision bearings, but incorporate silicon nitride ceramic balls. Silicon nitride is a material that improves wear characteristics, is chemically inert in harsh conditions, and has electrical insulating properties. Compared to traditional all-steel bearings, the service life of hybrid bearings can be increased by as much as ten times.

The silicon nitride ceramic material demonstrates a good combination of stiffness, hardness, wear resistance and density. The ceramic balls have 60% lower density than steel balls so that the centrifugal forces in the bearing are much reduced. The lighter balls also cause less alteration of the contact angle and increase the dynamic accuracy of the bearing.

A 70% smaller thermal expansion than for steel balls considerably reduces the influence of temperature changes on the bearing preload. It is therefore possible for hybrid bearings to operate at speeds which are some 20% higher than for all-steel bearings without any risk of uncontrolled preload increases occurring.

The modulus of elasticity of the ceramic material is some 50% greater than for steel. Thus hybrid bearings are stiffer, by up to 20% at elevated speeds. Power losses are reduced by approximately 10% compared with all-steel bearings. Most of the precision angular contact bearings available from MRC, can be furnished with silicon nitride balls, made-to-order.

Preload

For single bearings, preload is obtained first after mounting and depends on adjustment against a second bearing which can accommodate axial loads acting in the opposite direction to those acting on the first bearing.

Matched sets of two bearings arranged back-to-back or face-to-face are supplied with a light preload (G_A) as standard. Other preloads can be furnished on request. The degree of actual preload depends on the bearing series, the contact angle and the bearing size. These preloads are quoted in the tables on page 22 and are nominal values for bearings arranged back-to-back or face-to-face before mounting.

Matched sets of three, four or five bearings in tandem/back-to-back or tandem/face-to-face arrangements have greater preload than bearing pairs. The actual values can be obtained by multiplying the values given in the preload tables by the following factors:

- 1.35 triplex set
- 1.60 quad. set, 3DT + 1DB or DF
- 2.00 quad. set, One pair DT opposed by one pair DT
- 1.75 set of 5, 4DT + 1DB or DF
- 2.45 set of 5, 3DT + 1Pair DB or DF

Preload of Mounted Bearings

The values of preload given in the tables on page 22 apply to bearing sets before mounting. When mounted, the bearing sets will always have a higher preload. This increase is mainly determined by the fits and the stiffness of the bearing seatings on the shaft and in the housing.

If the bearings are mounted with normal interference fits (shaft seating to tolerance js4 and housing seating to JS5) and the shaft is of steel and the housing of steel or cast iron, with a sufficiently thick wall, the preload of the

mounted bearing sets can be calculated with reasonable accuracy from the equation

$$G_m = f f_1 f_2 G_A$$

where

G_m = preload of the mounted bearing sets, N

G_A = preload of bearing sets before mounting, corresponding to tables, page 22

f = bearing factor, see diagram opposite

f_1 = correction factor depending on contact angle, see table opposite

f_2 = correction factor depending on preload class, see table opposite

Example

Determine the mounted preload of the 7120KRDS - BKE#7 pair with a light preload (G_A) and mounted with a js4 shaft fit and a JS5 housing fit.

From the table on page 22, the value of G_A is 500 N. From the graph on the opposite page 21, $f = 1.8$, and from the table, $f_1 = 1.0$ and $f_2 = 0.92$. Then,

$$G_m = f f_1 f_2 G_A$$

$$G_m = 1.8 \times 1.0 \times 0.92 \times 500 = 828 \text{ N}$$

$$= 186 \text{ lbf}$$

Correction factors f_1 and f_2

Light Preload (G_A)

Bearing Series	Factors	
	f_1	f_2
71900DS-BKE#7	0.92	1
1900RDS-BKE#7	1	1
7100KRDS-BKE#7	0.92	1
100KRDS-BKE#7	1	1
7200DS-BKE#7	0.95	1
200RDS-BKE#7	1	1

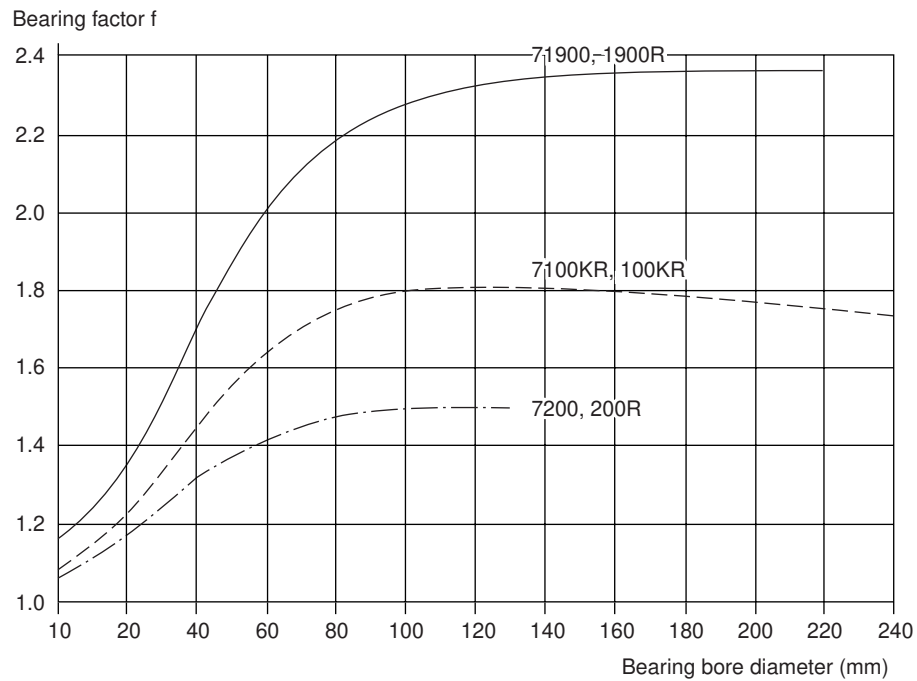

Light Axial Preload (G_A) in Matched Sets of Angular Contact Bearings

MRC Machine Tools

		Bearing													
Bore Dia mm	Size	1900R		100KR		200R		300R		71900		7100KR		7200	
		N	lbf	N	lbf	N	lbf	N	lbf	N	lbf	N	lbf	N	lbf
10	00	10	2	15	3	20	5	40	10	15	3	25	6	35	8
12	01	10	2	15	3	20	5	60	15	15	3	25	6	35	8
15	02	15	3	20	5	30	7	90	20	25	6	30	7	45	10
17	03	15	3	25	6	35	8	110	25	25	6	40	10	60	13
20	04	25	6	35	6	45	10	155	35	35	8	50	11	70	16
25	05	25	6	35	8	50	11	180	40	40	10	60	13	80	18
30	06	25	6	50	11	90	20	245	55	40	10	90	20	150	34
35	07	35	8	60	13	120	27	310	70	60	13	90	20	190	43
40	08	45	10	60	13	150	34	380	85	70	16	100	22	240	54
45	09	50	11	110	25	160	36	445	100	80	18	170	38	260	58
50	10	50	11	110	25	170	38	620	140	80	18	180	40	260	58
55	11	70	16	150	34	210	47	710	160	120	27	230	52	330	74
60	12	70	16	150	34	250	56	820	185	120	27	240	54	400	90
65	13	80	18	160	36	290	65			120	27	240	54	450	101
70	14	130	29	200	45	300	67			200	45	300	67	480	108
75	15	130	29	200	45	310	70			210	47	310	70	500	112
80	16	140	31	240	54	370	83			220	49	390	88	580	130
85	17	170	38	250	56	370	83			270	61	400	90	600	135
90	18	180	40	300	67	480	108			280	63	460	103	750	169
95	19	190	43	310	70	520	117			290	65	480	108	850	191
100	20	230	52	310	70	590	133			360	81	500	112	950	214
105	21	230	52	360	81	650	146			360	81	560	126	1000	225
110	22	230	52	420	94	670	151			370	83	650	146	1050	236
120	24	290	65	430	97	750	169			450	101	690	155	1200	270
130	26	350	79	560	126					540	121	900	202		
140	28	360	81	570	128					560	126	900	202		
150	30	470	106	650	146					740	166	1000	225		
160	32	490	110	730	164					800	180	1150	259		
170	34	500	112	800	180					800	180	1250	281		
180	36	630	142	900	202					1000	225	1450	326		
190	38	640	144	950	214					1000	225	1450	326		
200	40	800	180	1100	247					1250	281	1750	393		
220	44	850	191	1250	281					1300	292	2000	450		

Mounting Fits

The recommended shaft and housing bore diameters for precision angular contact bearings for machine tool spindle applications are shown in the table below, for a rotating shaft and stationary housing. The shaft tolerance is valid for both solid and hollow steel shafts.

Shaft Limits					
Shaft Diameter Nominal (mm)		js4 Tolerance			
		Millimeter		Inch	
Over	Incl.	High	Low	High	Low
6	10	+ .002	- .002	+ .00008	- .00008
10	18	+ .0025	- .0025	+ .0001	- .0001
18	30	+ .003	- .003	+ .0001	- .0001
30	50	+ .0035	- .0035	+ .00015	- .00015
50	80	+ .004	- .004	+ .00015	- .00015
80	120	+ .005	- .005	+ .0002	- .0002
120	180	+ .006	- .006	+ .00025	- .00025
180	250	+ .007	- .007	+ .0003	- .0003

Housing Bore Limits									
Housing Bore Diameter Nominal (mm)		Locating Bearing JS5 Tolerance				Floating Bearing H5 Tolerance			
		Millimeter		Inch		Millimeter		Inch	
Over	Incl.	High	Low	High	Low	High	Low	High	Low
18	30	+ .0045	- .0045	+ .0002	- .0002	+ .009	0	+ .00035	0
30	50	+ .0055	- .0055	+ .0002	- .0002	+ .011	0	+ .00045	0
50	80	+ .0065	- .0065	+ .00025	- .00025	+ .013	0	+ .0005	0
80	120	+ .0075	- .0075	+ .0003	- .0003	+ .015	0	+ .0006	0
120	180	+ .009	- .009	+ .00035	- .00035	+ .018	0	+ .0007	0
180	250	+ .010	- .010	+ .0004	- .0004	+ .020	0	+ .0008	0
250	315	+ .0115	- .0115	+ .00045	- .00045	+ .023	0	+ .0009	0
315	400	+ .0125	- .0125	+ .0005	- .0005	+ .025	0	+ .0010	0

Precision Angular Contact Ball Bearings

MRC Machine Tools

Tolerances in Inches (Shaded) and Millimeters

Inner Ring		2.5 10	10 18	18 30	30 50	50 80	80 120	120 150	150 180	180 250
Bore Diameter	Over Incl.									
Bore Diameter	+ .0000	-.00015 -.004	-.00015 -.004	-.0002 -.005	-.00025 -.006	-.0003 -.007	-.0003 -.008	-.0004 -.010	-.0004 -.010	-.00045 -.012
Bore Out-of-Round (Max)		.00005 .0013	.00005 .0013	.00005 .0013	.00005 .0013	.00008 .002	.0001 .0025	.00025 .006	.00025 .006	.0003 .007
Radial Runout (Max)		.00005 .0013	.00005 .0013	.0001 .0025	.0001 .0025	.0001 .0025	.0001 .0025	.00015 .004	.00025 .006	.0003 .007
Width Variation (Max)		.00005 .0013	.00005 .0013	.00005 .0013	.00005 .0013	.00005 .0013	.0001 .0025	.00015 .004	.00015 .004	.0002 .005
Side Runout With Bore (Max)		.00005 .0013	.00005 .0013	.00005 .0013	.00005 .0013	.00005 .0013	.0001 .0025	.00015 .004	.0002 .005	.00025 .006
Raceway Runout With Side (Max)		.00005 .0013	.00005 .0013	.0001 .0025	.0001 .0025	.0001 .0025	.0001 .0025	.00015 .004	.00025 .006	.0003 .007
Ring Width Single Bearing	+ .0000	-.0016 -.040	-.0031 -.080	-.0047 -.120	-.0047 -.120	-.0059 -.150	-.0079 -.200	-.0098 -.250	-.0098 -.250	-.0118 -.300
Ring Width Duplex Bearing	+ .0000	-.0098 -.250	-.0098 -.250	-.0098 -.250	-.0098 -.250	-.0098 -.250	-.0098 -.250	-.0150 -.380	-.0150 -.380	-.0197 -.500
Outer Ring										
Outside Diameter	Over Incl.	18 30	30 50	50 80	80 120	120 150	150 180	180 250	250 315	315 400
Outside Diameter	+ .0000	-.0002 -.005	-.00025 -.006	-.0003 -.007	-.0003 -.008	-.00035 -.009	-.0004 -.010	-.00045 -.011	-.0005 -.013	-.0006 -.015
Outside Diameter Out-of-Round (Max)		.00008 .002	.00008 .002	.00008 .002	.0001 .0025	.0001 .0025	.00025 .006	.00025 .006	.0003 .008	.0003 .009
Radial Runout (Max)		.0001 .0025	.0001 .0025	.00015 .0038	.0002 .005	.0002 .005	.00025 .006	.0003 .008	.00035 .009	.0004 .010
Width Variation (Max)		Identical to Inner Ring of Same Bearing								
O.D. Runout With Side (Max)		.00005 .0013	.00005 .0013	.00005 .0013	.0001 .0025	.0001 .0025	.00015 .004	.0002 .005	.00025 .006	.0003 .008
Raceway Runout With Side (Max)		.0001 .0025	.0001 .0025	.00015 .0038	.0002 .005	.0002 .005	.00025 .006	.0003 .008	.0003 .008	.0004 .010
Ring Width Single Bearing		Identical to Inner Ring of Same Bearing								
Ring Width Duplex Bearing		Identical to Inner Ring of Same Bearing								

Equivalent Bearing Loads

In machine tool spindle applications, angular contact bearings are often subjected to combined radial and axial loads. In these cases it is necessary to calculate an equivalent load which will have the same influence on bearing life as the actual loads. The method used is shown below, and in tables at right.

Equivalent Dynamic Radial Load

$$P = X F_R + Y F_A \quad P = \text{Equivalent dynamic radial load}$$

F_R = Radial load
 F_A = Thrust load
 X = Radial load factor
 Y = Thrust load factor

For single row angular contact bearings arranged singly or paired in tandem,

$$P = F_R \quad \text{when } F_A/F_R \leq e$$

$$P = X F_R + Y F_A \quad \text{when } F_A/F_R > e$$

For bearings paired back-to-back or face-to-face,

$$P = F_R + Y_1 F_A \quad \text{when } F_A/F_R \leq e$$

$$P = X F_R + Y_2 F_A \quad \text{when } F_A/F_R > e$$

Equivalent Static Radial Load

For single row angular contact bearings arranged singly or paired in tandem,

$$P_0 = 0.5 F_R + Y_0 F_A \quad P_0 = \text{equivalent static radial load}$$

P_0 is always $\geq F_R$ Y_0 = thrust load factor

For bearings paired back-to-back or face-to-face,

$$P_0 = F_R + Y_0 F_A$$

Load Ratings for Bearing Sets

For bearing sets of two or more bearings, multiply the single bearing dynamic rating C in the bearing tables by the following factors:

- 1.62 for two bearings
- 2.16 for three bearings
- 2.64 for four bearings
- 3.08 for five bearings

For static ratings, multiply the single bearing rating C_0 by the number of bearings in the set.

Calculation Factors for Single Bearings and Bearings Paired in Tandem

F_A/C_0	e	X	Y	Y_0
Contact Angle 15°				
≤ 0.015	0.38	0.44	1.47	0.46
0.029	0.40	0.44	1.40	0.46
0.058	0.43	0.44	1.30	0.46
0.087	0.46	0.44	1.23	0.46
0.12	0.47	0.44	1.19	0.46
0.17	0.50	0.44	1.12	0.46
0.29	0.55	0.44	1.02	0.46
≥ 0.44	0.56	0.44	1.00	0.46
Contact Angle 25°				
—	0.68	0.41	0.87	0.38

Calculation Factors for Bearings Paired Back-to-Back or Face-to-Face

$2F_A/C_0$	e	X	Y_1	Y_2	Y_0
Contact Angle 15°					
≤ 0.015	0.38	0.72	1.65	2.39	0.92
0.029	0.40	0.72	1.57	2.28	0.92
0.058	0.43	0.72	1.46	2.11	0.92
0.087	0.46	0.72	1.38	2.00	0.92
0.12	0.47	0.72	1.34	1.93	0.92
0.17	0.50	0.72	1.26	1.82	0.92
0.29	0.55	0.72	1.14	1.66	0.92
≥ 0.44	0.56	0.72	1.12	1.63	0.92
Contact Angle 25°					
—	0.68	0.67	0.92	1.41	0.76

Life Rating

$$L_{10} = \left(\frac{C}{P}\right)^3 \text{ (millions of revolutions)}$$

or

$$L_{10h} = \frac{10^6}{60n} \left(\frac{C}{P}\right)^3 \text{ (Hours)}$$

For DB or DF Mounting:

C = Duplex pair dynamic radial load rating (from duplex bearing tables) or

C = Single-row dynamic radial load rating times $(i)^{0.7}$, where $i = 2$ (See Load Ratings for Bearing Sets)

For tandem mounting:

C = Single-row dynamic radial load rating times $(i)^{0.7}$, where i = number of bearings in set (See Load Ratings for Bearing Sets)

P = Dynamic equivalent radial load

n = Speed in RPM

Dynamic and Static Equivalent Radial Load Calculation Examples

Bearing Size 109KRDS

Single Bearing Dynamic

$$F_R = 1890$$

$$F_A = 1250$$

$$F_A/C_0 = 1250/5040 = .25$$

$$e = .53$$

$$F_A/F_R = .66$$

$$\text{since } F_A/F_R > e, P = X F_R + Y F_A$$

$$X = .44, Y = 1.05$$

$$P = .44 \times 1890 + 1.05 \times 1250 = 2144$$

Single Bearing Static

$$F_R = 1500$$

$$F_A = 1000$$

$$P_0 = 0.5 F_R + Y_0 F_A$$

$$Y_0 = 0.46$$

$$P = 0.5 \times 1500 + 0.46 \times 1000 = 1210$$

$$\text{since } P_0 \text{ is always } \geq F_R,$$

$$P_0 = 1500$$

Paired Bearings Static (DB OR DF)

$$F_R = 1500$$

$$F_A = 2000$$

$$P_0 = F_R + Y_0 F_A$$

$$Y_0 = 0.92$$

$$P_0 = 1500 + 0.92 \times 2000 = 3340$$

Paired Bearings Dynamic (DB OR DF)

Case 1

$$F_R = 1890$$

$$F_A = 1250$$

$$2F_A/C_0 = 2500/5040 = .50$$

$$F_A/F_R = .66$$

$$e = .56$$

$$\text{Since } F_A/F_R > e, P = X F_R + Y_2 F_A$$

$$X = .72, Y_2 = 1.63$$

$$P = .72 \times 1890 + 1.63 \times 1250 = 3398$$

Case 2

$$F_R = 1890$$

$$F_A = 500$$

$$2F_A/C_0 = \frac{1000}{5040} = .20$$

$$F_A/F_R = .26$$

$$e = .53$$

$$\text{Since } F_A/F_R \leq e, P = F_R + Y_1 F_A$$

$$Y_1 = 1.23$$

$$P = 1890 + 1.23 \times 500 = 2505$$

Case 3

$$F_R = 0$$

$$F_A = 1250$$

$$2F_A/C_0 = .50$$

$$F_A/F_R = \infty$$

$$e = .56$$

$$\text{since } F_A/F_R > e, P = X F_R + Y_2 F_A$$

$$Y_2 = 1.63$$

$$P = 1.63 \times 1250 = 2038$$

Dynamic and Static Equivalent Radial Load Calculation Examples

Bearing Size 7210DS

Single Bearing Dynamic**Case 1**

$$F_R = 2000$$

$$F_A = 1000$$

$$F_A/F_R = 0.50$$

$$e = 0.68$$

$$\text{since } F_A/F_R \leq e,$$

$$P = F_R = 2000$$

Case 2

$$F_R = 1000$$

$$F_A = 2000$$

$$F_A/F_R = 2.0$$

$$e = 0.68$$

$$\text{since } F_A/F_R > e, P = X F_R + Y F_A$$

$$X = 0.41, Y = 0.87$$

$$P = 0.41 \times 1000 + 0.87 \times 2000 = 2150$$

Paired Bearings Dynamic (DB OR DF)**Case 1**

$$F_R = 2000$$

$$F_A = 1000$$

$$F_A/F_R = 0.50$$

$$e = 0.68$$

$$\text{since } F_A/F_R \leq e, P = F_R + Y_1 F_A$$

$$Y_1 = 0.92$$

$$P = 2000 + 0.92 \times 1000 = 2920$$

Case 2

$$F_R = 1000$$

$$F_A = 2000$$

$$F_A/F_R = 2.0$$

$$e = 0.68$$

$$\text{since } F_A/F_R > e, P = X F_R + Y_2 F_A$$

$$X = 0.67, Y_2 = 1.41$$

$$P = 0.67 \times 1000 + 1.41 \times 2000 = 3490$$

Single Bearing Static

$$F_R = 1500$$

$$F_A = 1000$$

$$P_0 = 0.5 F_R + Y_0 F_A$$

$$Y_0 = 0.38$$

$$P_0 = 0.5 \times 1500 + 0.38 \times 1000 = 1130$$

$$\text{since } P_0 \text{ is always } \geq F_R,$$

$$P_0 = 1500$$

Paired Bearings Static

$$F_R = 1000$$

$$F_A = 1500$$

$$P_0 = F_R + Y_0 F_A$$

$$Y_0 = 0.76$$

$$P_0 = 1000 + 0.76 \times 1500 = 2140$$

Effect of Preload on Total Axial Force (F_A)

For bearing pairs under radial load and mounted with interference fits,

$$F_A = G_m$$

For bearing pairs under radial load and preloaded by springs,

$$F_A = G_A$$

For bearing pairs under axial load and preloaded by springs,

$$F_A = G_A + K_a$$

For bearing pairs under axial load and mounted with interference fits,

$$F_A = G_m + 0.67 K_a \quad \text{when } K_a \leq 3 G_m$$

$$F_A = K_a \quad \text{when } K_a > 3 G_m$$

where

F_A = axial component of bearing load

G_A = preload of bearing pair from table on page 22

G_m = preload in mounted pair, see page 20

K_a = external axial force acting on single bearing

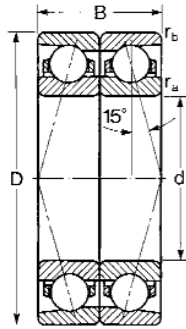

Load ratings are for single bearings. For sets of two or more see page 25 for the multiplying factor.

Speed ratings are for single bearings. For the speed reduction factor for sets of two or more, or tandem arrangements, see page 19.

Caution: Single bearings are not to be used where only radial loads are present. For two-direction thrust loads, use duplex bearings.

MRC Bearing Number	Bore d		Outside Diameter D		Width B		Fillet Radius ¹⁾				Basic Radial Load Rating				Speed Rating	
							r _a		r _b		Dynamic C ²⁾		Static C ₀			
	mm	in	mm	in	mm	in	mm	in	mm	in	N	lbf	N	lbf	Grease RPM	Oil RPM
1900RDS-BKE#7	10	.3737	22	.8661	12	.4724	.30	.012	.10	.004	2510	565	1100	247	70000	110000
1901RDS-BKE#7	12	.4724	24	.9449	12	.4724	.30	.012	.10	.004	2650	595	1250	281	63000	95000
1902RDS-BKE#7	15	.5906	28	1.1024	14	.5512	.30	.012	.10	.004	3970	892	1900	427	56000	85000
1903RDS-BKE#7	17	.6693	30	1.1811	14	.5512	.30	.012	.10	.004	4160	935	2080	468	50000	75000
1904RDS-BKE#7	20	.7874	37	1.4567	18	.7087	.30	.012	.15	.006	6050	1360	3200	719	43000	63000
1905RDS-BKE#7	25	.9843	42	1.6535	18	.7087	.30	.012	.15	.006	6760	1520	4000	899	36000	53000
1906RDS-BKE#7	30	1.1811	47	1.8504	18	.7087	.30	.012	.15	.006	7150	1610	4550	1020	30000	45000
1907RDS-BKE#7	35	1.3780	55	2.1654	20	.7874	.60	.024	.15	.006	9750	2190	6550	1470	26000	40000
1908RDS-BKE#7	40	1.5748	62	2.4409	24	.9449	.60	.024	.15	.006	12400	2790	8500	1910	20000	34000
1909RDS-BKE#7	45	1.7717	68	2.6772	24	.9449	.60	.024	.15	.006	13000	2920	9500	2140	19000	32000
1910RDS-BKE#7	50	1.9685	72	2.8346	24	.9449	.60	.024	.15	.006	13500	3030	10400	2340	17000	28000
1911RDS-BKE#7	55	2.1654	80	3.1496	26	1.0236	1.0	.040	.30	.012	19500	4380	14600	3280	16000	26000
1912RDS-BKE#7	60	2.3622	85	3.3465	26	1.0236	1.0	.040	.30	.012	19900	4470	15300	3440	15000	24000
1913RDS-BKE#7	65	2.5591	90	3.5433	26	1.0236	1.0	.040	.30	.012	20800	4680	17000	3820	14000	22000
1914RDS-BKE#7	70	2.7559	100	3.9370	32	1.2598	1.0	.040	.30	.012	34500	7760	34000	7640	13000	20000
1915RDS-BKE#7	75	2.9528	105	4.1339	32	1.2598	1.0	.040	.30	.012	35800	8050	37500	8430	12000	19000
1916RDS-BKE#7	80	3.1496	110	4.3307	32	1.2598	1.0	.040	.30	.012	36400	8180	39000	8770	11000	18000
1917RDS-BKE#7	85	3.3465	120	4.7244	36	1.4173	1.1	.043	.60	.024	46200	10400	48000	10800	10000	17000
1918RDS-BKE#7	90	3.5433	125	4.9213	36	1.4173	1.1	.043	.60	.024	47500	10700	51000	11500	9500	16000
1919RDS-BKE#7	95	3.7402	130	5.1181	36	1.4173	1.1	.043	.60	.024	49400	11100	55000	12400	9000	15000
1920RDS-BKE#7	100	3.9370	140	5.5118	40	1.5748	1.1	.043	.60	.024	60500	13600	65500	14700	8500	14000
1921RDS-BKE#7	105	4.1339	145	5.7087	40	1.5748	1.1	.043	.60	.024	61800	13900	69500	15600	8500	14000
1922RDS-BKE#7	110	4.3307	150	5.9055	40	1.5748	1.1	.043	.60	.024	62400	14000	72000	16200	8000	13000
1924RDS-BKE#7	120	4.7244	165	6.4961	44	1.7323	1.1	.043	.60	.024	78000	17500	91500	20600	7500	12000
1926RDS-BKE#7	130	5.1181	180	7.0866	48	1.8898	1.5	.060	.60	.024	92300	20700	108000	24300	7000	11000
1928RDS-BKE#7	140	5.5118	190	7.4803	48	1.8898	1.5	.060	.60	.024	95600	21500	116000	26100	6700	10000
1930RDS-BKE#7	150	5.9055	210	8.2677	56	2.2047	2.0	.080	1.0	.040	125000	28100	146000	32800	6300	9500

¹⁾ Fillet radius indicates maximum fillet radius on shaft or in housing which bearing corner will clear.

²⁾ Rating for one million revolutions or 500 hours at 33 1/3 RPM.

Precision 15° Angular Contact 100KRDS-BKE#7 Series, Duplex

MRC Machine Tools

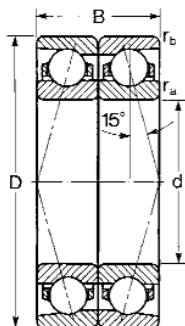

Load ratings are for single bearings. For sets of two or more see page 25 for the multiplying factor.

Speed ratings are for single bearings. For the speed reduction factor for sets of two or more, or tandem arrangements, see page 19.

Caution: Single bearings are not to be used where only radial loads are present. For two-direction thrust loads, use duplex bearings.

MRC Bearing Number	Bore d		Outside Diameter D		Width B		Fillet Radius ¹⁾				Basic Radial Load Rating				Speed Rating	
							r _a		r _b		Dynamic C ²⁾		Static C ₀		Grease RPM	Oil RPM
	mm	in	mm	in	mm	in	mm	in	mm	in	N	lbf	N	lbf		
100KRDS-BKE#7	10	0.3937	26	1.0236	16	0.63	.30	0.012	.10	0.004	4100	922	1660	373	67000	100000
101KRDS-BKE#7	12	0.4724	28	1.1024	16	0.63	.30	0.012	.10	0.004	4490	1010	1900	427	60000	90000
102KRDS-BKE#7	15	0.5906	32	1.2598	18	0.7086	.30	0.012	.10	0.004	5200	1170	2450	551	50000	75000
103KRDS-BKE#7	17	0.6693	35	1.378	20	0.7874	.30	0.012	.10	0.004	6760	1520	3250	731	48000	70000
104KRDS-BKE#7	20	0.7874	42	1.6535	24	0.9448	.60	0.024	.30	0.012	8710	1960	4300	967	38000	56000
105KRDS-BKE#7	25	0.9843	47	1.8504	24	0.9448	.60	0.024	.30	0.012	9560	2150	5200	1170	34000	50000
106KRDS-BKE#7	30	1.1811	55	2.1654	26	1.0236	1.0	0.04	.30	0.012	14300	3210	8000	1800	28000	43000
107KRDS-BKE#7	35	1.378	62	2.4409	28	1.1024	1.0	0.04	.30	0.012	15600	3510	9500	2140	22000	36000
108KRDS-BKE#7	40	1.5748	68	2.6772	30	1.1812	1.0	0.04	.30	0.012	16800	3780	11000	2470	19000	32000
109KRDS-BKE#7	45	1.7717	75	2.9528	32	1.2598	1.0	0.04	.30	0.012	28600	6430	22400	5040	18000	30000
110KRDS-BKE#7	50	1.9685	80	3.1496	32	1.2598	1.0	0.04	.30	0.012	29600	6650	24000	5400	17000	28000
111KRDS-BKE#7	55	2.1654	90	3.5433	36	1.4174	1.1	0.043	.60	0.024	39700	8920	32500	7310	15000	24000
112KRDS-BKE#7	60	2.3622	95	3.7402	36	1.4174	1.1	0.043	.60	0.024	40300	9060	34500	7760	14000	22000
113KRDS-BKE#7	65	2.5591	100	3.937	36	1.4174	1.1	0.043	.60	0.024	41600	9350	37500	8430	14000	22000
114KRDS-BKE#7	70	2.7559	110	4.3307	40	1.5748	1.1	0.043	.60	0.024	52000	11700	45000	10100	12000	19000
115KRDS-BKE#7	75	2.9528	115	4.5276	40	1.5748	1.1	0.043	.60	0.024	52700	11800	49000	11000	11000	18000
116KRDS-BKE#7	80	3.1496	125	4.9213	44	1.7322	1.1	0.043	.60	0.024	65000	14600	61000	13700	10000	17000
117KRDS-BKE#7	85	3.3465	130	5.1181	44	1.7322	1.1	0.043	.60	0.024	67600	15200	65500	14700	9500	16000
118KRDS-BKE#7	90	3.5433	140	5.5118	48	1.8898	1.5	0.06	.60	0.024	79300	17800	76500	17200	9000	15000
119KRDS-BKE#7	95	3.7402	145	5.7087	48	1.8898	1.5	0.06	.60	0.024	81900	18400	80000	18000	8500	14000
120KRDS-BKE#7	100	3.937	150	5.9055	48	1.8898	1.5	0.06	.60	0.024	83200	18700	85000	19100	8500	14000
121KRDS-BKE#7	105	4.1339	160	6.2992	52	2.0472	2.0	0.08	1.0	0.04	95600	21500	96500	21700	8000	13000
122KRDS-BKE#7	110	4.3307	170	6.6929	56	2.2048	2.0	0.08	1.0	0.04	111000	25000	108000	24300	7500	12000
124KRDS-BKE#7	120	4.7244	180	7.0866	56	2.2048	2.0	0.08	1.0	0.04	114000	25600	122000	27400	7000	11000
126KRDS-BKE#7	130	5.1181	200	7.874	66	2.5984	2.0	0.08	1.0	0.04	148000	33300	156000	35100	6700	10000
128KRDS-BKE#7	140	5.5118	210	8.2677	66	2.5984	2.0	0.08	1.0	0.04	153000	34400	166000	37300	6700	10000
130KRDS-BKE#7	150	5.9055	225	8.8583	70	2.756	2.1	0.083	1.0	0.04	172000	38700	190000	42700	6000	9000
132KRDS-BKE#7	160	6.2992	240	9.4488	76	2.9922	2.1	0.083	1.0	0.04	195000	43800	216000	48600	5600	8500
134KRDS-BKE#7	170	6.6929	260	10.2362	84	3.307	2.1	0.083	1.1	0.043	212000	47700	245000	55100	5300	8000
136KRDS-BKE#7	180	7.0866	280	11.0236	92	3.622	2.1	0.083	1.1	0.043	242000	54400	290000	65200	5000	7500
138KRDS-BKE#7	190	7.4803	290	11.4173	92	3.622	2.1	0.083	1.1	0.043	247000	55500	300000	67400	4800	7000
140KRDS-BKE#7	200	7.874	310	12.2047	102	4.0158	2.1	0.083	1.1	0.043	296000	66500	390000	87700	4500	6700
144KRDS-BKE#7	220	8.6614	340	13.3858	112	4.4094	3.0	0.12	1.1	0.043	338000	76000	455000	102000	4000	6000

¹⁾ Fillet radius indicates maximum fillet radius on shaft or in housing which bearing corner will clear.

²⁾ Rating for one million revolutions or 500 hours at 33 1/3 RPM.

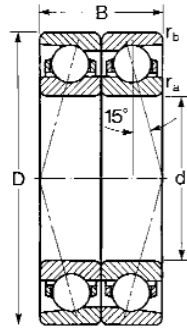

Load ratings are for single bearings. For sets of two or more see page 25 for the multiplying factor.

Speed ratings are for single bearings. For the speed reduction factor for sets of two or more, or tandem arrangements, see page 19.

Caution: Single bearings are not to be used where only radial loads are present. For two-direction thrust loads, use duplex bearings.

MRC Bearing Number	Bore d		Outside Diameter D		Width B		Fillet Radius ¹⁾				Basic Radial Load Rating				Speed Rating	
							r _a		r _b		Dynamic C ²⁾		Static C ₀		Grease RPM	Oil RPM
	mm	in	mm	in	mm	in	mm	in	mm	in	N	lbf	N	lbf		
200RDS-BKE#7	10	0.3937	30	1.1811	18	0.7086	.60	0.024	.30	0.012	5400	1210	2200	495	60000	90000
201RDS-BKE#7	12	0.4724	32	1.2598	20	0.7874	.60	0.024	.30	0.012	5850	1320	2550	573	53000	80000
202RDS-BKE#7	15	0.5906	35	1.378	22	0.8662	.60	0.024	.30	0.012	7410	1670	3350	753	48000	70000
203RDS-BKE#7	17	0.6693	40	1.5748	24	0.9448	.60	0.024	.30	0.012	9230	2070	4150	933	43000	63000
204RDS-BKE#7	20	0.7874	47	1.8504	28	1.1024	1.0	0.04	.30	0.012	11900	2680	5850	1320	36000	53000
205RDS-BKE#7	25	0.9843	52	2.0472	30	1.1812	1.0	0.04	.30	0.012	13500	3030	7200	1620	30000	45000
206RDS-BKE#7	30	1.1811	62	2.4409	32	1.2598	1.0	0.04	.30	0.012	24200	5440	16000	3600	24000	38000
207RDS-BKE#7	35	1.378	72	2.8346	34	1.3386	1.1	0.043	.30	0.012	31900	7170	21600	4860	20000	34000
208RDS-BKE#7	40	1.5748	80	3.1496	36	1.4174	1.1	0.043	.60	0.024	41000	9220	28000	6290	18000	30000
209RDS-BKE#7	45	1.7717	85	3.3465	38	1.496	1.1	0.043	.60	0.024	42300	9510	31000	6970	17000	28000
210RDS-BKE#7	50	1.9685	90	3.5433	40	1.5748	1.1	0.043	.60	0.024	44900	10100	34000	7640	16000	26000
211RDS-BKE#7	55	2.1654	100	3.937	42	1.6536	1.5	0.06	.60	0.024	55300	12400	43000	9670	14000	22000
212RDS-BKE#7	60	2.3622	110	4.3307	44	1.7322	1.5	0.06	.60	0.024	67600	15200	53000	11900	13000	20000
213RDS-BKE#7	65	2.5591	120	4.7244	46	1.811	1.5	0.06	.60	0.024	76100	17100	60000	13500	12000	19000
214RDS-BKE#7	70	2.7559	125	4.9213	48	1.8898	1.5	0.06	.60	0.024	79300	17800	64000	14400	11000	18000
215RDS-BKE#7	75	2.9528	130	5.1181	50	1.9686	1.5	0.06	0.6	0.024	83200	18700	69500	15600	10000	17000
216RDS-BKE#7	80	3.1496	140	5.5118	52	2.0472	2.0	0.08	1.0	0.040	97500	21900	81500	18300	9500	16000
217RDS-BKE#7	85	3.3465	150	5.9055	56	2.2048	2.0	0.08	1.0	0.040	99500	22400	88000	19800	9000	15000
218RDS-BKE#7	90	3.5433	160	6.2992	60	2.3622	2.0	0.08	1.0	0.040	127000	28500	112000	25200	2500	14000
219RDS-BKE#7	95	3.7402	170	6.6929	64	2.5196	2.1	0.083	1.1	0.043	138000	31000	120000	27000	8000	13000
220RDS-BKE#7	100	3.937	180	7.0866	68	2.6772	2.1	0.083	1.1	0.043	156000	35100	137000	30800	7500	12000
221RDS-BKE#7	105	4.1339	190	7.4803	72	2.8346	2.1	0.083	1.1	0.043	172000	38700	153000	34400	7500	12000
222RDS-BKE#7	110	4.3307	200	7.874	76	2.9922	2.1	0.083	1.1	0.043	178000	40000	166000	37300	7000	11000
224RDS-BKE#7	120	4.7244	215	8.4646	80	3.1496	2.1	0.083	1.1	0.043	199000	44700	193000	43400	6700	10000

¹⁾ Fillet radius indicates maximum fillet radius on shaft or in housing which bearing corner will clear.

²⁾ Rating for one million revolutions or 500 hours at 33 1/3 RPM.

Precision 15° Angular Contact 300 RDS-BKE#7 Series, Duplex

MRC Machine Tools

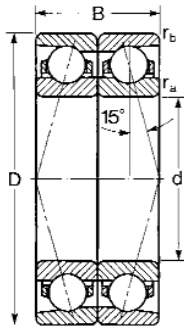

Load ratings are for single bearings. For sets of two or more see page 25 for the multiplying factor.

Speed ratings are for single bearings. For the speed reduction factor for sets of two or more, or tandem arrangements, see page 19.

Caution: Single bearings are not to be used where only radial loads are present. For two-direction thrust loads, use duplex bearings.

MRC Bearing Number	Bore d		Outside Diameter D		Width B		Fillet Radius ¹⁾				Basic Radial Load Rating				Speed Rating	
							r _a		r _b		Dynamic C ²⁾		Static C ₀		Grease RPM	Oil RPM
	mm	in	mm	in	mm	in	mm	in	mm	in	N	lbf	N	lbf		
300RDS-BKE#7	10	0.3937	35	1.357	22	0.8662	.60	0.024	.60	0.024	10500	2360	4550	1020	46000	73000
301RDS-BKE#7	12	0.4724	37	1.4567	24	0.9454	1.0	0.04	1.0	0.04	10600	2380	4900	1100	44000	67000
302RDS-BKE#7	15	0.5906	42	1.6535	26	1.0236	1.0	0.04	1.0	0.04	12100	2720	6550	1470	39000	56000
303RDS-BKE#7	17	0.6693	47	1.8504	28	1.1024	1.0	0.04	1.0	0.04	14800	3330	8150	1830	37000	53000
304RDS-BKE#7	20	0.7874	52	2.0472	30	1.1812	1.1	0.043	1.1	0.043	20300	4560	11400	2560	30000	45000
305RDS-BKE#7	25	0.9843	62	2.4409	34	1.3386	1.1	0.043	1.1	0.043	23400	5260	15300	3440	25000	39000
306RDS-BKE#7	30	1.1811	72	2.8346	38	1.496	1.1	0.043	1.1	0.043	31200	7010	20000	4500	21000	31000
307RDS-BKE#7	35	1.378	80	3.1496	42	1.6536	1.5	0.06	1.5	0.06	39700	8920	26000	5850	20000	28000
308RDS-BKE#7	40	1.5748	90	3.5433	46	1.811	1.5	0.06	1.5	0.06	48800	11000	33500	7530	17000	25000
309RDS-BKE#7	45	1.7717	100	3.937	50	1.9686	1.5	0.06	1.5	0.06	58500	13200	40500	9100	15000	22000
310RDS-BKE#7	50	1.9685	110	4.3307	54	2.126	2.0	0.08	2.0	0.08	76100	17100	52000	11700	14000	21000
311RDS-BKE#7	55	2.1654	120	4.7244	58	2.2834	2.0	0.08	2.0	0.08	88400	19900	61000	13700	13000	19000
312RDS-BKE#7	60	2.3622	130	5.1181	62	2.441	2.1	0.083	2.1	0.083	101000	22700	71000	16000	12000	17000

¹⁾ Fillet radius indicates maximum fillet radius on shaft or in housing which bearing corner will clear.

²⁾ Rating for one million revolutions or 500 hours at 33 1/3 RPM.

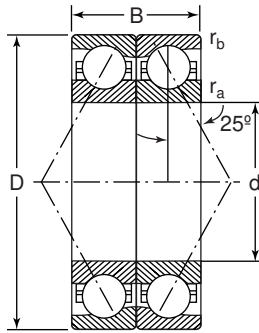

Load ratings are for single bearings. For sets of two or more see page 25 for the multiplying factor.

Speed ratings are for single bearings. For the speed reduction factor for sets of two or more, or tandem arrangements, see page 19.

Caution: Single bearings are not to be used where only radial loads are present. For two-direction thrust loads, use duplex bearings.

MRC Bearing Number	Bore d		Outside Diameter D		Width B		Fillet Radius ¹⁾				Basic Radial Load Rating				Speed Rating	
							r _a		r _b		Dynamic C ²⁾		Static C ₀			
	mm	in	mm	in	mm	in	mm	in	mm	in	N	lbf	N	lbf	Grease RPM	Oil RPM
71900DS-BKE#7	10	.3737	22	.8661	12	.4724	.30	.012	.10	.004	2420	544	1060	238	63000	95000
71901DS-BKE#7	12	.4724	24	.9449	12	.4724	.30	.012	.10	.004	2550	573	1180	265	56000	85000
71902DS-BKE#7	15	.5906	28	1.1024	14	.5512	.30	.012	.10	.004	3770	847	1800	405	50000	75000
71903DS-BKE#7	17	.6693	30	1.1811	14	.5512	.30	.012	.10	.004	3970	892	2000	450	45000	67000
71904DS-BKE#7	20	.7874	37	1.4567	18	.7087	.30	.012	.15	.006	5720	1290	3050	686	38000	56000
71905DS-BKE#7	25	.9843	42	1.6535	18	.7087	.30	.012	.15	.006	6370	1430	3800	854	32000	48000
71906DS-BKE#7	30	1.1811	47	1.8504	18	.7087	.30	.012	.15	.006	6760	1520	4300	967	26000	40000
71907DS-BKE#7	35	1.3780	55	2.1654	20	.7874	.60	.024	.15	.006	9230	2070	6200	1390	22000	36000
71908DS-BKE#7	40	1.5748	62	2.4409	24	.9449	.60	.024	.15	.006	11700	2630	8000	1800	18000	30000
71909DS-BKE#7	45	1.7717	68	2.6772	24	.9449	.60	.024	.15	.006	12400	2790	9000	2020	17000	28000
71910DS-BKE#7	50	1.9685	72	2.8346	24	.9449	.60	.024	.15	.006	12700	2850	9800	2200	16000	26000
71911DS-BKE#7	55	2.1654	80	3.1496	26	1.0236	1.0	.040	.30	.012	18200	4090	13700	3080	15000	24000
71912DS-BKE#7	60	2.3622	85	3.3465	26	1.0236	1.0	.040	.30	.012	18600	4180	14600	3280	14000	22000
71913DS-BKE#7	65	2.5591	90	3.5433	26	1.0236	1.0	.040	.30	.012	19500	4380	16000	3600	13000	20000
71914DS-BKE#7	70	2.7559	100	3.9370	32	1.2598	1.0	.040	.30	.012	32500	7310	32500	7310	11000	18000
71915DS-BKE#7	75	2.9528	105	4.1339	32	1.2598	1.0	.040	.30	.012	33800	7600	35500	7980	10000	17000
71916DS-BKE#7	80	3.1496	110	4.3307	32	1.2598	1.0	.040	.30	.012	34500	7760	36500	8210	9500	16000

¹⁾ Fillet radius indicates maximum fillet radius on shaft or in housing which bearing corner will clear.

²⁾ Rating for one million revolutions or 500 hours at 33 1/3 RPM.

Precision 25° Angular Contact 7100 KRDS-BKE#7 Series, Duplex

MRC Machine Tools

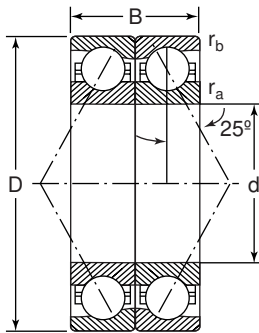

Load ratings are for single bearings. For sets of two or more see page 25 for the multiplying factor.

Speed ratings are for single bearings. For the speed reduction factor for sets of two or more, or tandem arrangements, see page 19.

Caution: Single bearings are not to be used where only radial loads are present. For two-direction thrust loads, use duplex bearings.

MRC Bearing Number	Bore d		Outside Diameter D		Width B		Fillet Radius ¹⁾				Basic Radial Load Rating				Speed Rating	
							r _a		r _b		Dynamic C ²⁾		Static C ₀		Grease RPM	Oil RPM
	mm	in	mm	in	mm	in	mm	in	mm	in	N	lbf	N	lbf		
7100KRDS-BKE#7	10	0.3937	26	1.0236	16	0.63	.30	0.012	.10	0.004	3970	892	1600	360	56000	85000
7101KRDS-BKE#7	12	0.4724	28	1.1024	16	0.63	.30	0.012	.10	0.004	4360	980	1830	411	53000	80000
7102KRDS-BKE#7	15	0.5906	32	1.2598	18	0.7086	.30	0.012	.10	0.004	4940	1110	2320	522	45000	67000
7103KRDS-BKE#7	17	0.6693	35	1.378	20	0.7874	.30	0.012	.10	0.004	6500	1460	3100	697	40000	60000
7104KRDS-BKE#7	20	0.7874	42	1.6535	24	0.9448	.60	0.024	.30	0.012	8320	1870	4150	933	34000	50000
7105KRDS-BKE#7	25	0.9843	47	1.8504	24	0.9448	.60	0.024	.30	0.012	9230	2070	5000	1120	28000	43000
7106KRDS-BKE#7	30	1.1811	55	2.1654	26	1.0236	1.0	0.04	.30	0.012	13800	3100	7650	1720	24000	38000
7107KRDS-BKE#7	35	1.378	62	2.4409	28	1.1024	1.0	0.04	.30	0.012	14800	3330	9000	2020	19000	32000
7108KRDS-BKE#7	40	1.5748	68	2.6772	30	1.1812	1.0	0.04	.30	0.012	15900	3570	10400	2340	18000	30000
7109KRDS-BKE#7	45	1.7717	75	2.9528	32	1.2598	1.0	0.04	.30	0.012	27600	6070	21600	4860	16000	26000
7110KRDS-BKE#7	50	1.9685	80	3.1496	32	1.2598	1.0	0.04	.30	0.012	28100	6320	23200	5220	15000	24000
7111KRDS-BKE#7	55	2.1654	90	3.5433	36	1.4174	1.1	0.043	.60	0.024	37100	8340	31000	6740	14000	22000
7112KRDS-BKE#7	60	2.3622	95	3.7402	36	1.4174	1.1	0.043	.60	0.024	39000	8770	33500	7530	13000	20000
7113KRDS-BKE#7	65	2.5591	100	3.937	36	1.4174	1.1	0.043	.60	0.024	39000	8770	35500	7980	12000	19000
7114KRDS-BKE#7	70	2.7559	110	4.3307	40	1.5748	1.1	0.043	.60	0.024	48800	11000	44000	9890	10000	17000
7115KRDS-BKE#7	75	2.9528	115	4.5276	40	1.5748	1.1	0.043	.60	0.024	49400	11100	46500	10500	9500	16000
7116KRDS-BKE#7	80	3.1496	125	4.9213	44	1.7322	1.1	0.043	.60	0.024	62400	14000	58500	13200	9000	15000
7117KRDS-BKE#7	85	3.3465	130	5.1181	44	1.7322	1.1	0.043	.60	0.024	63700	14300	62000	13900	8500	14000
7118KRDS-BKE#7	90	3.5433	140	5.5118	48	1.8898	1.5	0.06	.60	0.024	74100	16700	72000	16200	8000	13000
7119KRDS-BKE#7	95	3.7402	145	5.7087	48	1.8898	1.5	0.06	.60	0.024	76100	17100	76500	17200	8000	13000
7120KRDS-BKE#7	100	3.937	150	5.9055	48	1.8898	1.5	0.06	.60	0.024	79300	17800	80000	18000	7500	12000
7121KRDS-BKE#7	105	4.1339	160	6.2992	52	2.0472	2.0	0.08	1.0	0.04	90400	20300	93000	20900	7500	12000
7122KRDS-BKE#7	110	4.3307	170	6.6929	56	2.2048	2.0	0.08	1.0	0.04	104000	23400	104000	23400	7000	11000
7124KRDS-BKE#7	120	4.7244	180	7.0866	56	2.2048	2.0	0.08	1.0	0.04	111000	25000	116000	26100	6700	10000
7126KRDS-BKE#7	130	5.1181	200	7.814	66	2.5984	2.0	0.08	1.0	0.04	140000	31500	150000	33700	6000	9000
7128KRDS-BKE#7	140	5.5118	210	8.2677	66	2.5984	2.0	0.08	1.0	0.04	146000	32800	156000	35100	5600	8500
7130KRDS-BKE#7	150	5.9055	225	8.8583	70	2.756	2.1	0.083	1.0	0.04	163000	36600	180000	40500	5300	8000

¹⁾ Fillet radius indicates maximum fillet radius on shaft or in housing which bearing corner will clear.

²⁾ Rating for one million revolutions or 500 hours at 33 1/3 RPM.

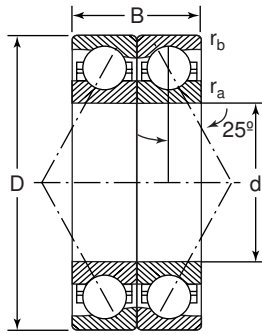

Load ratings are for single bearings. For sets of two or more see page 25 for the multiplying factor.

Speed ratings are for single bearings. For the speed reduction factor for sets of two or more, or tandem arrangements, see page 19.

Caution: Single bearings are not to be used where only radial loads are present. For two-direction thrust loads, use duplex bearings.

MRC Bearing Number	Bore d		Outside Diameter D		Width B		Fillet Radius ¹⁾				Basic Radial Load Rating				Speed Rating	
							r _a		r _b		Dynamic C ²⁾		Static C _o		Grease RPM	Oil RPM
	mm	in	mm	in	mm	in	mm	in	mm	in	N	lbf	N	lbf		
7200DS-BKE#7	10	0.3937	30	1.1811	18	0.7086	.60	0.024	.30	0.012	5200	1170	2120	477	53000	80000
7201DS-BKE#7	12	0.4724	32	1.2598	20	0.7874	.60	0.024	.30	0.012	5720	1290	2450	551	48000	70000
7202DS-BKE#7	15	0.5906	35	1.378	22	0.8662	.60	0.024	.30	0.012	7150	1610	3200	719	43000	63000
7203DS-BKE#7	17	0.6693	40	1.5748	24	0.9448	.60	0.024	.30	0.012	8840	1990	4000	899	38000	56000
7204DS-BKE#7	20	0.7874	47	1.8504	28	1.1024	1.0	0.04	.30	0.012	11400	2560	5600	1260	32000	48000
7205DS-BKE#7	25	0.9843	52	2.0472	30	1.1812	1.0	0.04	.30	0.012	13000	2920	6950	1560	26000	40000
7206DS-BKE#7	30	1.1811	62	2.4409	32	1.2598	1.0	0.04	.30	0.012	23400	5260	15300	3440	20000	34000
7207DS-BKE#7	35	1.378	72	2.8346	34	1.3386	1.1	0.043	.30	0.012	30700	6900	20800	4680	18000	30000
7208DS-BKE#7	40	1.5748	80	3.1496	36	1.4174	1.1	0.043	.60	0.024	39000	8770	27000	6070	16000	26000
7209DS-BKE#7	45	1.7717	85	3.3465	38	1.496	1.1	0.043	.60	0.024	41000	9220	30000	6740	15000	24000
7210DS-BKE#7	50	1.9685	90	3.5433	40	1.5748	1.1	0.043	.60	0.024	42300	9510	32500	7310	14000	22000
7211DS-BKE#7	55	2.1654	100	3.937	42	1.6536	1.5	0.06	.60	0.024	52700	11800	40500	9100	13000	20000
7212DS-BKE#7	60	2.3622	110	4.3307	44	1.7322	1.5	0.06	.60	0.024	63700	14800	50000	11200	11000	18000
7213DS-BKE#7	65	2.5591	120	4.7244	46	1.811	1.5	0.06	.60	0.024	72800	16400	57000	12800	10000	17000
7214DS-BKE#7	70	2.7559	125	4.9213	48	1.8898	1.5	0.06	.60	0.024	76100	17100	62000	13900	9500	16000

¹⁾ Fillet radius indicates maximum fillet radius on shaft or in housing which bearing corner will clear.

²⁾ Rating for one million revolutions or 500 hours at 33 1/3 RPM.

High Precision Bearings For Ex-Cell-O Spindles

MRC Machine Tools

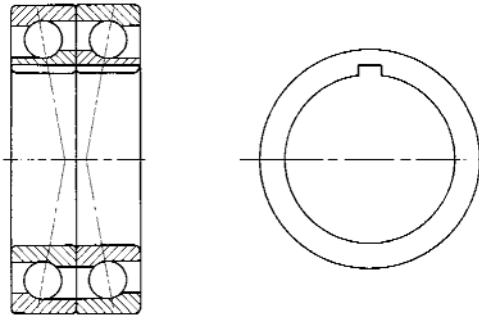

Each MRC bearing made for Ex-Cell-O[®], spindles is a separable inner ring type with counterbored outer ring, with the cage and ball assembly remaining together as a unit. The bearings are manufactured to a basic ABEC-7 grade with a minus tolerance on the nominal bore and O.D. The cage, which is outer ring land-guided, has a chamfer on the bore to provide for improved flow of lubricant.

These bearings are packed in pairs, with one bearing of the pair marked with a single burnished dot on both inner and outer ring faces. The other bearing is marked with two burnished dots on both the inner and outer rings. These dots help avoid mixing of the separable bearing parts and also indicate high points of eccentricity on inner and outer rings.

Identification Markings

Ball bearings furnished for replacement use are identical to those provided for Ex-Cell-O OEM use except for identification markings. The small table below shows typical markings on inner and outer rings of MRC replacement bearings and Ex-Cell-O bearings.

	MRC Replacement Bearings	Ex-Cell-O OEM Bearings
Inner Ring	MRC USA D	MRC USA D
Outer Ring	XO-30-RBDS-16	XLO-30-57

Note that both the OEM and replacement bearings have the same marking on the inner ring—MRC USA D. However, on the outer ring of the OEM bearings, a typical marking shows XLO-30-57: XLO is the Ex-Cell-O trademark, 30 indicates the basic bearing size, 57 denotes preload group 5 (not preload in pounds) and tolerance grade ABEC-7. MRC replacement bearings are marked XO-30-RBDS-16 on the outer ring: XO designates Ex-Cell-O bearings, 30 shows the basic bearing number, RBDS indicates duplex bearings with a preload of 16 pounds.

Shaft and House Fitting Practices

Basic dimensions of this new Ex-Cell-O bearing series remain the same as bearings previously furnished. The only external dimensional differences are in the bore and O.D. tolerances, and these must be considered when replacing the old series bearings. Current fitting practices in Ex-Cell-O spindles are 0.0001" tight to 0.0001" loose on the shaft, 0.0003" loose to 0.0005" loose in the floating end of the housing and 0.0001" loose to 0.0003" loose in the held end of the housing. Therefore, it may be necessary to alter shaft and housing seat diameters to retain correct fitting practices.

How To Order

The dimension table on the next two pages provides all MRC replacement bearing numbers and corresponding Ex-Cell-O part numbers. When ordering, specify MRC bearing number, operating speed or preload, or both to assure delivery of proper bearing for application.

Difference Between Old and New Types

Basic external dimensions are the same with only a change in tolerance of the bore and O.D. in the new type. The new ball cage provides a chamfer on the bore for better flow of lubricant. One shoulder of the inner ring is low enough to permit separation from the outer ring, ball and cage assembly.

© Ex-Cell-O is a registered trademark of Ex-Cell-O GmbH.

MRC Replacement Bearing Number	X-L-O Part Number	Bore d		Outside Diameter D		Width B		Keyway			
		mm	in	mm	in	mm	in	e		f	
								mm	in	mm	in
XO-20-RBDS	20-27 20-107	9.53	.37500	28.58	1.1250	17.46	.6875	9.9	.3906	1.6	.063
XO-30-RBDS	30-17 30-27 30-57 30-77 30-107	15.88	.62500	38.10	1.5000	25.4	1.000	16.4	.645	1.6	.063
XO-55-RBDS	55-17 55-27 55-57 55-87 55-107	20.64	.81250	50.80	2.0000	25.4	1.000	21.4	.844	1.6	.063
XO-57-RBDS	57-17 57-27 57-57 57-87 57-107	26.99	1.06250	57.15	2.2500	25.4	1.000	27.5	1.082	1.6	.063
XO-67-RBDS	67-17 67-37 67-57 67-87 67-107	31.75	1.2500	61.91	2.4375	31.75	1.250	32.6	1.285	3.2	.125
XO-90-RBDS	90-17 90-47 90-57 90-67 90-77 90-107	41.28	1.6250	87.31	3.4375	41.28	1.625	42.2	1.660	3.2	.125
XO-115-RBDS	115-17 115-27 115-37 115-47 115-57 115-77	57.15	2.2500	120.7	4.7500	57.15	2.250	58.4	2.300	4.7	.187
XO-135-RBDS	135-27 135-47 135-67 135-77 135-107	31.75	1.2500	68.26	2.6875	31.75	1.250	32.6	1.285	3.2	.125
XO-155-RBDS	155-07 155-17 155-37 155-47 155-67 155-87 155-107	69.85	2.7500	120.7	4.7500	57.15	2.250	70.9	2.790	4.7	.187
XO-165-RBDS	165-17 165-27 165-47 165-57 165-67 165-87	88.90	3.5000	160.3	6.3125	76.2	3.000	89.5	3.525	6.4	.250

High Precision Bearings For Ex-Cell-O Spindles

MRC Machine Tools

MRC Replacement Bearing Number	Fillet Radius ¹⁾ r _a		Pre-Load Lbs.	Maximum Speed (RPM)		
	mm	In		Grease Lub.	Oil Lub.	Mist Lub.
XO-20-RBDS	.6	.025	10	35000	45000	60000
			0	40000	65000	80000
XO-30-RBDS	1.0	.040	40	6000	9000	12000
			30	10000	12500	18000
			16	27000	30000	35000
			10	30000	35000	45000
			0	35000	40000	60000
XO-55-RBDS	1.0	.040	80	2000	4000	6000
			50	5000	8000	12000
			30	20000	22000	24000
			10	22000	24000	32000
			0	24000	27000	45000
XO-57-RBDS	1.0	.040	90	2000	4000	6000
			50	5000	8000	12000
			15	20000	22000	24000
			10	22000	24000	32000
			0	24000	27000	45000
XO-67-RBDS	1.0	.040	92	3600	4500	6000
			60	6000	8000	12000
			20	12500	15000	22000
			10	14000	18000	28000
			0	16000	20000	35000
XO-90-RBDS	1.5	.060	325	1000	2000	4000
			180	3000	5000	8000
			120	5000	7000	11000
			72	8000	10000	14000
			40	10000	14000	20000
			0	12000	16000	22000
XO-115-RBDS	2.0	.080	450	750	1500	2250
			350	1000	2000	3000
			200	2200	3500	6000
			150	3000	4500	7000
			100	4000	5000	8000
			30	6000	8000	15000
XO-135-RBDS	1.0	.040	175	1000	2000	4000
			90	3600	4500	6000
			60	6000	7500	12000
			25	10000	12000	18000
			0	15000	19000	28000
XO-155-RBDS	2.0	.080	1000	250	250	250
			450	500	1000	1500
			325	1000	2000	3000
			250	2500	3500	5000
			150	4000	5000	6500
			60	6000	7000	10000
0	7000	9000	12000			
XO-165-RBDS	2.0	.080	1200	500	800	1200
			800	500	1000	2000
			400	1000	2000	4000
			250	2000	3000	5000
			175	3000	4000	6000
			50	5000	6500	9000

¹⁾ Fillet radius indicates maximum fillet radius on shaft or in housing which bearing corner will clear.

*Precision Double Row Cylindrical Roller Bearings
with Tapered Bore*

Section IV



High precision cylindrical roller bearings are bearings with a low cross section, high load carrying capacity and speed capability. These properties make them particularly suitable for machine tool applications where spindle bearing arrangements are required to support heavy loads and have high stiffness.

MRC can furnish the NN style double row cylindrical roller bearing with a tapered bore in the 31 series. The tapered bore (Taper 1:12) allows adjustment in mounting to a given radial internal clearance or preload. The rollers are guided by integral flanges in the inner ring. The inner ring, cage and roller assembly is separable from the outer ring for simplification of mounting and dismounting. To facilitate lubrication, bearings with a bore diameter of 50 mm and over have an annular groove and three oil holes in the outer ring.

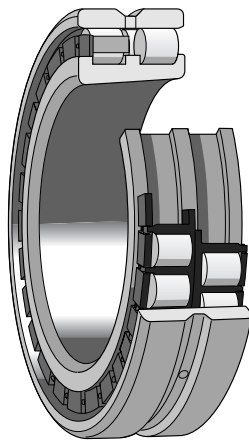

NN31X Series

Tolerances

High precision cylindrical roller bearings are manufactured to tolerances specifically defined for machine tool applications. The tolerances are shown in the table on page 44.

Cages

The NN 31 series incorporates two separate polyamide cages as standard. Machined brass is furnished on some sizes; either material is suitable at temperatures normally encountered, in machine tool applications, and are not affected by lubricants commonly used, with the exception of some synthetic oils or greases with synthetic base oils.

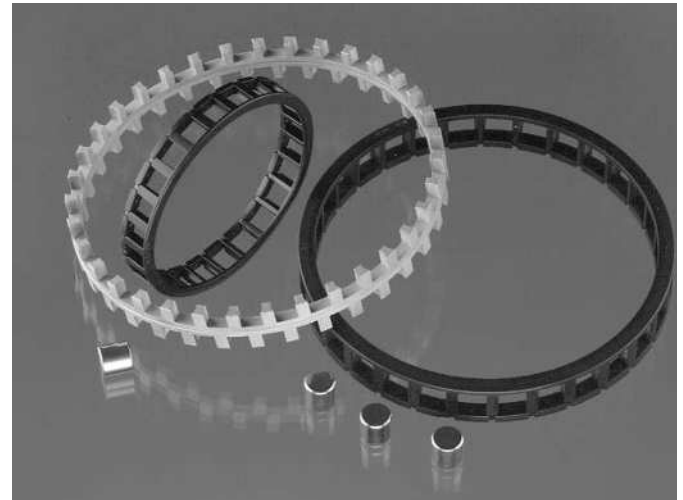

Cages for double row cylindrical roller bearings

Internal Clearance

The NN 31X series are manufactured to a C1 internal radial clearance as standard as shown in the table below. Clearance greater than C1 can be furnished on request.

Bore Diameter d		C1 Internal Clearance			
Over	Incl	Min		Max	
mm		mm	in	mm	in
24	30	.015	.0006	.025	.0010
30	40	.015	.0006	.025	.0010
40	50	.017	.0007	.030	.0012
50	65	.020	.0008	.035	.0014
65	80	.025	.0010	.040	.0016
80	100	.035	.0014	.055	.0022
100	120	.040	.0016	.060	.0024
120	140	.045	.0018	.070	.0028
140	160	.050	.0020	.075	.0030
160	180	.055	.0022	.085	.0033
180	200	.060	.0024	.090	.0035
200	225	.060	.0024	.095	.0037
225	250	.065	.0026	.100	.0039
250	280	.075	.0030	.110	.0043
280	315	.080	.0031	.120	.0047

Speed Ratings

The ratings quoted in the bearing tables are guideline values which apply provided the bearings have a maximum preload in operation of $2\ \mu\text{m}$ (.00008 in) and the associated components are made with the recommended accuracy. Where heavier preloads occur or where the associated components are less accurate, the speed ratings must be reduced.

Internal Clearance or Preload in Mounted Bearings

To ensure maximum running accuracy and stiffness of the complete machine tool spindle, the bearings should have a minimum radial internal clearance or a preload after mounting. Because of this, cylindrical roller bearings with tapered bore are generally mounted with preload.

The magnitude of the operational clearance or preload in a bearing depends on the speed, load, lubrication and requisite stiffness. It is also dependent on the accuracy of form of the bearing seatings. Temperature conditions in the bearing should also be taken into consideration, since a reduction in clearance or an increase in preload can result.

The maximum preload for bearings operating at relatively slow speeds lies between .001 and .004 mm (.0004 and .0016 in) depending on bearing size and must be appropriately reduced at higher speeds.

Adjustment of Clearance or Preload

The adjustment of clearance or preload for double and single row cylindrical roller bearings with tapered bore is achieved by driving up the bearing on its tapered seating. The axial displacement of the inner ring on its tapered seating must be determined in accordance with the required preload or clearance. In order to do this, the outer ring should be mounted in the housing, the inner ring then pushed on to the seating and the residual clearance measured.

A method often used to measure the clearance is shown in the adjacent figure. The spindle end under load A is incrementally unloaded and the values shown by the dial gauge C (which should be as close as possible to the bear-

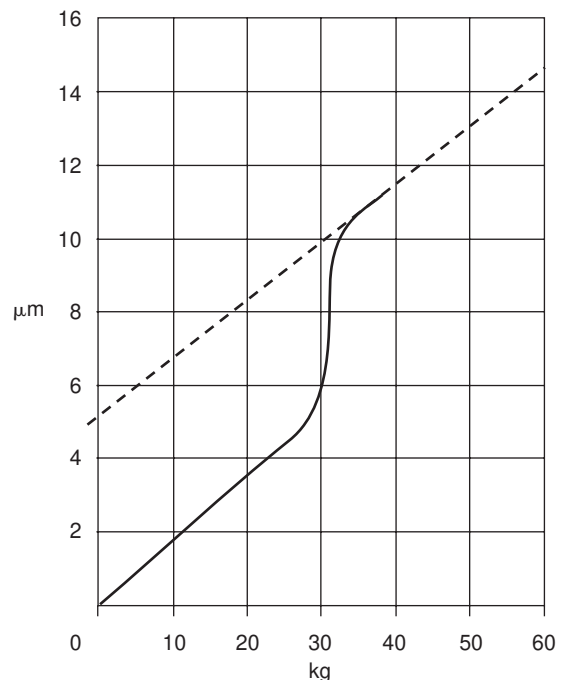
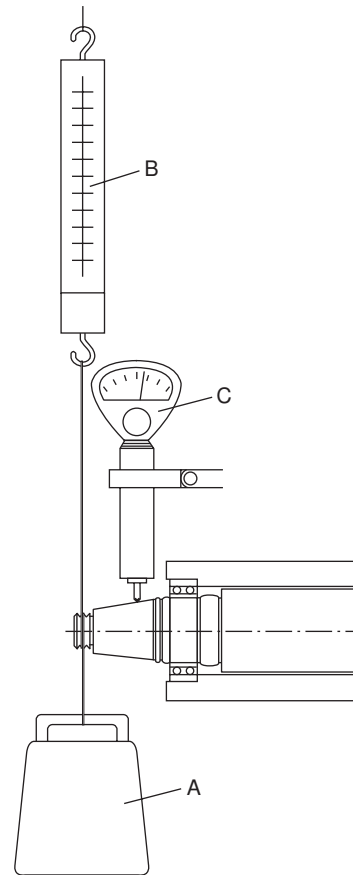

ing) and the spring balance B are read off. The force directed upwards should be increased until it exceeds the load A, which acts downwards. If the values that are read off are plotted on a graph, a curve will be obtained, which resembles that shown in the adjacent diagram. The two inclined sections of the curve represent spindle resilience, whereas the vertical distance between slopes represents the magnitude of the radial internal clearance; in the case shown, this is 5 μm. To obtain maximum accuracy when measuring, other bearings or even seals, which could restrict movement of the spindle, should not be mounted in the vicinity of the bearing being measured.

Using the value so obtained for the radial internal clearance, the axial displacement, i.e. the additional distance through which the bearing must be pushed up on to its tapered seating, can be obtained from the formula shown below.

$$B_a = \frac{ec}{1\ 000}$$

where

B_a = axial displacement, mm

e = factor depending on bearing series, see adjacent table

c = requisite clearance reduction, including any preload, μm

If the bearing is to be mounted against a distance ring, e.g. as shown in the adjacent figure, the width of the distance ring must be appropriate to the value obtained for B_a . In all other cases, the axial displacement must be measured from a reference surface on the spindle.

Example

How large is the axial displacement, i.e. the distance which bearing NN 3132X should be pushed further up on to its tapered seating, if

- the measured radial internal clearance is 10 μm,
- the requisite preload is 2 μm
- the mean bearing seating diameter $d_m = 163$ mm, and
- the internal diameter of the hollow spindle $d_i = 120$ mm

Using $e = 18$ for $d_i/d_m = 120/163 = 0.74$ from the adjacent table and $c = 10 + 2 = 12$ μm, then

$$B_a = \frac{ec}{1\ 000} = \frac{18 \times 12}{1\ 000} = 0.216 \text{ mm}$$

Factor e	
Diameter Ratio d_i/d_m	Factor e Bearing Series NN 31 X
≤0.2	12.5
0.3	14.5
0.4	15
0.5	16
0.6	17
0.7	18

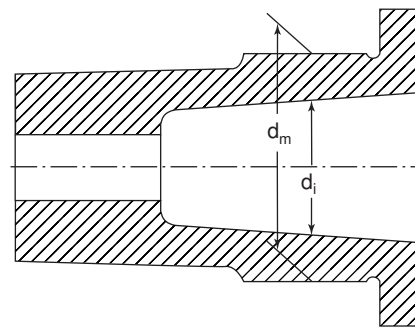
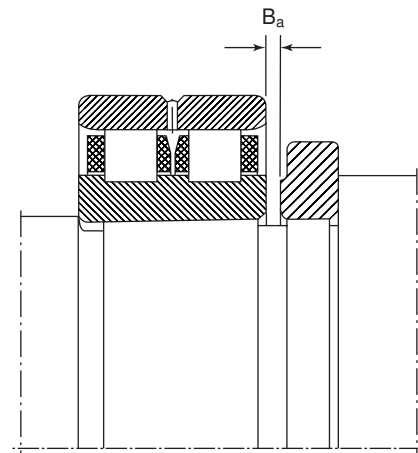

Tolerances in Inches (Shaded) and Millimeters

MRC Machine Tools

Inner Ring									
Bore Diameter (mm)	Over Incl.	10 18	18 30	30 50	50 80	80 120	120 150	150 180	180 250
Bore		.0001	.0001	.00015	.0002	.0002	.0003	.0003	.0003
Out-of-Round (Max)		.003	.003	.004	.005	.005	.007	.007	.008
Radial Runout (Max)		.0001	.0001	.00015	.00015	.0002	.00025	.00025	.0003
		.003	.003	.004	.004	.005	.006	.006	.008
Width Variation (Max)		.0002	.0002	.0002	.00025	.0003	.0003	.0003	.0004
		.005	.005	.005	.006	.007	.008	.008	.010
Side Runout With Bore (Max)		.0003	.0003	.0003	.0003	.00035	.0004	.0004	.00045
		.008	.008	.008	.008	.009	.010	.010	.011
Ring Width	+.0000	-.0039	-.0039	-.0047	-.0059	-.0079	-.0098	-.0098	-.0118
		-.100	-.100	-.120	-.150	-.200	-.250	-.250	-.300

Outer Ring									
Outside Diameter	Over Incl.	30 50	50 80	80 120	120 150	150 180	180 250	250 315	315 400
Outside Diameter	+.0000	-.0003	-.00035	-.0004	-.00045	-.0005	-.0006	-.0007	-.0008
		-.007	-.009	-.010	-.011	-.013	-.015	-.018	-.020
Outside Diameter Out-of-Round (Max)		.00015	.0002	.0002	.00025	.0003	.0003	.00035	.0004
		.004	.005	.005	.006	.007	.008	.009	.010
Radial Runout (Max)		.0002	.0002	.00025	.0003	.0003	.0004	.00045	.0005
		.005	.005	.006	.007	.008	.010	.011	.013
Width Variation (Max)		Identical to inner ring of same bearing							
O.D. Runout With Side (Max)		.0003	.0003	.00035	.0004	.0004	.00045	.0005	.0005
		.008	.008	.009	.010	.010	.011	.013	.013
Ring Width		Identical to inner ring of same bearing							

Tolerances for Tapered Bore							
Bore Diameter d (mm)	Over Incl.	18 30	30 50	50 80	80 120	120 180	180 250
d ₁	-.0000	+.0004	+.00045	+.0006	+.0008	+.0010	+.0012
		+.010	+.012	+.015	+.020	+.025	+.030
d ₁ - d ₂ ¹⁾	-.0000	+.00015	+.00015	+.0002	+.00025	+.0003	+.0004
		+.004	+.004	+.005	+.006	+.008	+.010

¹⁾ Angular deviation over measuring length m

d₁ mean bore diameter at large end of tapered bore; arithmetical mean of largest and smallest single bore diameters at distance a

d₂ mean bore diameter at small end of tapered bore; arithmetical mean of largest and smallest single bore diameters at distance a

Tapered bore

Half angle taper $\alpha = 2^\circ 23' 9.4''$

Housing Fits

The recommended housing bore diameters for precision double row cylindrical rollers bearings for machine tool spindle applications are shown in the table below, for a rotating shaft and stationary housing. The recommended interference for precision double row cylindrical rollers bearings is 0-2 μm .

Housing Bore Limits											
Housing Bore Diameter Nominal (mm)		Normal & Light Loads K5 Tolerance				Heavy Loads & Rotating Outerring Loads M5 Tolerance					
		Millimeter		Inch		Millimeter		Inch			
		Over	Incl.	High	Low	High	Low	High	Low		
18	30			+0.001	-0.008	+0.00004	-0.0003	-0.005	-0.014	-0.0002	-0.0006
30	50			+0.002	-0.009	+0.0001	-0.00035	-0.006	-0.016	-0.0002	-0.0006
50	80			+0.003	-0.010	+0.0001	-0.0004	-0.006	-0.019	-0.0002	-0.0007
80	120			+0.002	-0.013	+0.0001	-0.0005	-0.008	-0.023	-0.0003	-0.0009
120	180			+0.003	-0.015	+0.0001	-0.0006	-0.009	-0.027	-0.00035	-0.0011
180	250			+0.002	-0.018	+0.0001	-0.0007	-0.011	-0.031	-0.0004	-0.0012
250	315			+0.003	-0.020	+0.0001	-0.0008	-0.013	-0.036	-0.0005	-0.0014
315	400			+0.003	-0.022	+0.0001	-0.0009	-0.014	-0.039	-0.0006	-0.0015

Precision Double Row Cylindrical Roller Bearings with Tapered Bore

MRC Machine Tools

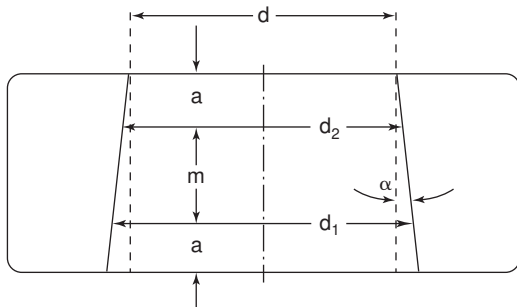

$\alpha = 2^\circ 23' 9.4''$
(1:12 taper)

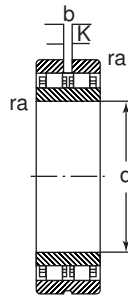

Measuring Distance a				
Chamfer Dimension r_2 (min)		Measuring Distance a		
mm	in	mm	in	
0.6	.024	2.5	.098	
1.0	.039	3.0	.118	
1.1	.043	4.0	.157	
1.5	.060	5.0	.197	
2.0	.080	5.5	.217	
2.1	.083	6.0	.236	

MRC Bearing Number	Bore d		Outside Diameter D		Width B		Fillet ¹ Radius r_a		b		k		Basic Radial Load Rating				Speed Rating		
													Dynamic C^2		Static C_0				
	mm	in	mm	in	mm	in	mm	in	mm	in	mm	in	N	lbf	N	lbf	Grease RPM	Oil RPM	
NN3107X	35	1.3780	62	2.4409	20	.7874	1	1.0	.040	—	—	—	—	39100	8790	50000	11200	14000	16000
NN3108X	40	1.5748	68	2.6772	21	.8268	1	1.0	.040	—	—	—	—	42900	9640	56000	12600	12000	14000
NN3109X	45	1.7717	75	2.9528	23	.9055	1	1.0	.040	—	—	—	—	50100	11300	65500	14700	11000	13000
NN3110X	50	1.9685	80	3.1496	23	.9055	1	1.0	.040	3.7	.146	2.0	.080	52800	11900	73500	16500	10000	12000
NN3111X	55	2.1654	90	3.5433	26	1.0236	1.1	1.0	.040	3.7	.146	2.0	.080	69300	15600	96500	21700	9500	11000
NN3112X	60	2.3622	95	3.7402	26	1.0236	1.1	1.0	.040	3.7	.146	2.0	.080	73700	16600	106000	23800	9000	10000
NN3113X	65	2.5591	100	3.9370	26	1.0236	1.1	1.0	.040	3.7	.146	3.0	.118	76500	17200	116000	26100	8500	9500
NN3114X	70	2.7559	110	4.3307	30	1.1811	1.1	1.0	.040	5.5	.217	3.0	.118	96800	21800	150000	33700	7500	8500
NN3115X	75	2.9528	115	4.5276	30	1.1811	1.1	1.0	.040	5.5	.217	3.0	.118	96800	21800	150000	33700	7000	8000
NN3116X	80	3.1496	125	4.9213	34	1.3386	1.1	1.0	.040	5.5	.217	3.0	.118	119000	26800	186000	41800	6700	7500
NN3117X	85	3.3465	130	5.1181	34	1.3386	1.1	1.0	.040	5.5	.217	3.0	.118	125000	28100	204000	45900	6300	7000
NN3118X	90	3.5433	140	5.5118	37	1.4567	1.5	1.5	.060	5.5	.217	3.0	.118	138000	31000	216000	48600	6000	6700
NN3119X	95	3.7402	145	5.7087	37	1.4567	1.5	1.5	.060	5.5	.217	3.0	.118	142000	31900	232000	52200	5600	6300
NN3120X	100	3.9370	150	5.9055	37	1.4567	1.5	1.5	.060	5.5	.217	3.0	.118	151000	33900	250000	56200	5300	6000
NN3121X	105	4.1339	160	6.2992	41	1.6142	2	2.0	.080	5.5	.217	3.0	.118	190000	42700	305000	68600	5000	5600
NN3122X	110	4.3307	170	6.6929	45	1.7717	2	2.0	.080	5.5	.217	3.0	.118	220000	49500	360000	80900	4800	5300
NN3124X	120	4.7244	180	7.0866	46	1.8110	2	2.0	.080	5.5	.217	3.0	.118	229000	51500	390000	87700	4500	5000
NN3126X	130	5.1181	200	7.8740	52	2.0472	1.1	2.0	.080	8.3	.327	4.5	.177	286000	64300	475000	107000	4000	4500
NN3128X	140	5.5118	210	8.2677	53	2.0866	2	2.0	.080	8.3	.327	4.5	.177	297000	66800	520000	117000	3800	4300
NN3130X	150	5.9055	225	8.8583	56	2.2047	2.1	2.0	.080	8.3	.327	4.5	.177	330000	74200	570000	128000	3600	4000
NN3132X	160	6.2992	240	9.4488	60	2.3622	2.1	2.0	.080	8.3	.327	4.5	.177	369000	83000	655000	147000	3400	3800

¹) Fillet radius indicates maximum fillet radius on shaft or in housing which bearing corner will clear.
²) Rating for one million revolutions or 500 hours at 33 1/3 rpm.

Single Direction Ball Screw Support Bearings

Section V



The MRC ball screw support bearing is a single row angular contact, non-separable ball bearing with one heavy shoulder and one low shoulder on each ring, on opposite sides. Construction and ring design permit a greater number of balls than standard angular contact types, and with a 60° contact angle, a very high thrust load-carrying capacity and maximum axial stiffness are attained. As heavy thrust loads must be taken in both directions, these ball screw support bearings are mounted in duplex pairs, back-to-back or face-to-face, or in triplex or quadruple sets if greater support is required.

The sets of bearings are matched during production so that when mounted immediately adjacent to each other, the predetermined value of the preload and/or an even distribution of the load will be obtained. The bore and outside diameters of the bearings of a set differ at the most by half the permissible tolerance range.

To facilitate proper mounting of sets, the bearing O.D. surface is etched with a “V” pointing in the direction of the thrust acting on the inner ring. When the thrust load acts in both directions the direction of the greater thrust should be considered. An example of marking is shown below for a triplex set.

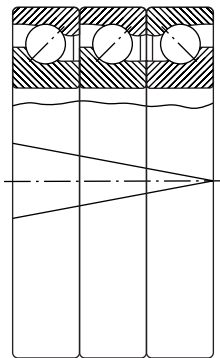

Universal Mounting

Ball screw support bearings are manufactured so that they can be mounted in random order in back-to-back or face-to-face pairs, or triplex and quadruple sets. Regardless of the arrangement, the proper preload will be maintained. When ordering, the number of individual bearings must be specified.

Pairs of two bearings are also available with matched bore and outside diameters. Some of the sets listed in the bearing tables have this special matching.

Cages

MRC ball screw support bearings are fitted with a ball-centered cage of injection moulded polyamide 6.6. Generally, these cages may be used at temperatures up to +110°C (230°F) although brief periods at higher temperatures will not have a detrimental effect provided they are interspersed with long periods at lower temperatures.

The lubricants normally employed with rolling bearings generally have no adverse effect on cage properties, with the exception of a few synthetic oils and greases based on such oils and some lubricants containing large proportions of EP additives, particularly at high temperatures.

Speed Ratings

The speed ratings given in the bearing tables are guideline values and apply to single bearings. Speed ratings for matched sets of 2, 3 or 4 bearings are obtained by multiplying the values given in the table by

- 0.80 for sets of 2 bearings
- 0.65 for sets of 3 bearings
- 0.50 for sets of 4 bearings

Tolerances

MRC ball screw support bearings are made to the tolerances shown in the table on page 50. These correspond to ABEC-7 and ISO Class 4 specifications (ISO 492) although the standards only apply to radial bearings. The values quoted refer to single bearings.

Maximum and minimum values quoted for a single diameter or height represent the permissible deviations from the nominal dimensions given in the bearing tables.

The axial runout (lateral eccentricity) of a single direction angular contact thrust ball bearing is an important parameter. For matched sets which are correctly mounted on accurately machined seatings, the axial runout will generally not exceed 0.0025 mm (.0001 inches).

		Tolerances in Inches (Shaded) and Millimeters					
d,D (mm)	Over	10	18	30	50	80	120
	Incl	18	30	50	80	120	150
d _s	Max	.0000	.0000	.0000	.0000	.0000	—
		.000	.000	.000	.000	.000	—
	Min	-.00015	-.00015	-.0002	-.0002	-.00025	—
		-.0038	-.0038	-.0050	-.005	-.0065	
D _s	Max	—	—	.0000	.0000	.0000	.0000
				.000	.000	.000	.000
	Min	—	—	-.0002	-.0002	-.0003	-.0004
				-.005	-.005	-.0075	-.010
B	Max	.0000	.0000	.0000	.0000	.0000	—
		.000	.000	.000	.000	.000	—
	Min	-.0031	-.0047	-.0047	-.0059	-.0079	—
		-.080	-.120	-.120	-.150	-.200	
S _i , S _e	Max	.00008	.0001	.0001	.0001	.0001	.0001
		.002	.0025	.0025	.0025	.0025	.0025

Symbols

- d nominal bore diameter
- d_s single diameter of bore
- D nominal outside diameter
- D_s single diameter of outside cylindrical surface
- S_i, S_e width variation, measured from middle of race-way to back (seating face) of inner ring and outer ring, respectively (axial runout)
- B bearing width, single bearing

Preload

All bearing sets of two bearings arranged back-to-back or face-to-face are available with preload to class A and class B (Table 1). The values given in the table refer to unmounted bearing pairs, i.e. the bearing rings are free to expand. This means that after mounting the preload will increase; the greater the increase, the tighter the fit applied.

Matched sets of 3 and 4 bearings arranged back-to-back or face-to-face have a higher preload. The appropriate values can be obtained by multiplying the values given in the table by the factors in Table 2.

Axial Stiffness

Ball screw support bearings are designed for high stiffness. The actual values are given in Table 1 and apply to bearing sets of two bearings arranged back-to-back or face-to-face.

Matched sets of 3 and 4 bearings arranged back-to-back or face-to-face have a higher axial stiffness. The appropriate values can be obtained by multiplying the values given in the table by the factors in Table 2.

Friction Torque

MRC ball screw support bearings have low friction. The actual values for the torque are given in Table 1 and are valid for unmounted bearing sets of two bearings.

Matched sets of 3 and 4 bearings arranged back-to-back or face-to-face have a higher friction torque. The appropriate values can be obtained by multiplying the values given in the table by the factors in Table 2.

Table 1

MRC bearing number	Preload class				Axial stiffness				Friction torque			
	A		B		A		B		A		B	
	N	lbf	N	lbf	N/μm	lbf/μm	N/μm	lbf/μm	Nm	lbf-ft	Nm	lbf-ft
J1232	650	146	1300	292	345	78	440	99	.016	.012	.029	.021
J1535	775	174	1550	348	408	92	522	117	.023	.017	.040	.030
J2047	1480	333	2960	665	587	132	750	169	.056	.041	.100	.074
J2552	1580	355	3160	710	632	142	807	181	.077	.057	.132	.097
J3062	2250	506	4500	1010	809	182	1036	233	.130	.096	.225	.166
J2047A	1480	333	2960	665	587	132	750	169	.056	.041	.100	.074
J2562	2400	540	4800	1080	785	176	1000	225	.120	.089	.215	.159
J3062A	2250	506	4500	1010	809	182	1036	233	.130	.096	.224	.165
J3572	2950	663	5900	1330	960	216	1228	276	.200	.148	.345	.254
J4072	2950	663	5900	1330	960	216	1228	276	.200	.148	.345	.254
J093	2400	540	4800	1080	785	176	1000	225	.120	.089	.215	.159
J175	2900	652	5800	1300	1065	239	1335	300	.255	.188	.415	.306

¹⁾ All sizes stocked with class A except J2047 and J093 are class B. Non-stocked preloads furnished on special order.

Table 2

Set	Multiplication factors		
	Preload	Axial stiffness	Friction torque
3 Bearings 1 PR DT, 1/2 PR DB or DF	1.35	1.45	1.35
4 Bearings 1 1/2 PR DT, 1/2 PR DB or DF	1.60	1.80	1.55
4 Bearings 1 PR DT vs 1 PR DT Mounted DB or DF	2.00	2.00	2.00

The equivalent dynamic radial load for single bearings and any configuration of bearings in a set can be calculated from the following:

$$P = Y F_A + X F_R \quad \text{when } F_A/F_R \leq 2.17$$

$$P = F_A + 0.92 F_R \quad \text{when } F_A/F_R > 2.17$$

where,

P = equivalent dynamic radial load

F_A = thrust load (including preload)

F_R = radial load

X = radial load factor

Y = thrust load factor

The X and Y factors can be obtained from the table on the next page.

Bearing arrangement	Load carrying capacity of bearing set ¹⁾		Calculation factors $F_A/F_R \leq 2.17$	
	Dynamic	Static	X	Y
2 Bearings DB or DF	C	C_0	1.9	0.55
2 Bearings in Tandem (DT)	1.62 C	$2 C_0$	—	—
3 Bearings in Tandem (DT)	2.16 C	$3 C_0$	—	—
3 Bearings ²⁾ 1 Pair DT, 1/2 Pair DB or DF	1.62 C	$2 C_0$	2.3	0.35
4 Bearings ²⁾ 1 1/2 Pair DT, 1/2 Pair DB or DF	2.16 C	$3 C_0$	2.52	0.26
4 Bearings 1 Pair DT vs 1 Pair DT Mounted DB or DF	1.62 C	$2 C_0$	1.9	0.55
4 Bearings in Tandem (DT)	2.64 C	$4 C_0$	—	—

¹⁾ C and C_0 are the basic dynamic and static load ratings of a single bearing (see Bearing Tables).

²⁾ Thrust on DT set.

Equivalent Static Radial Load

The equivalent static radial load may be calculated from:

$$P_0 = F_A + 4F_R$$

where,

P_0 = static equivalent radial load

F_A = thrust load (including preload)

F_R = radial load

The equation is also valid for single bearings and bearings arranged in tandem when the ratio F_R/F_A does not exceed

0.25, and gives satisfactory but less accurate values when F_R/F_A is more than 0.25 but less than 0.40.

Ball screw support bearings are manufactured to a high degree of accuracy and are primarily intended for the support of precision ball screws in numerically controlled machine tools and in robots. However, to achieve the desired running and positioning accuracy, the associated components must also have a corresponding precision. Deviations in dimensions from the geometrical form must be as small as possible. Recommended tolerances are shown on page 53.

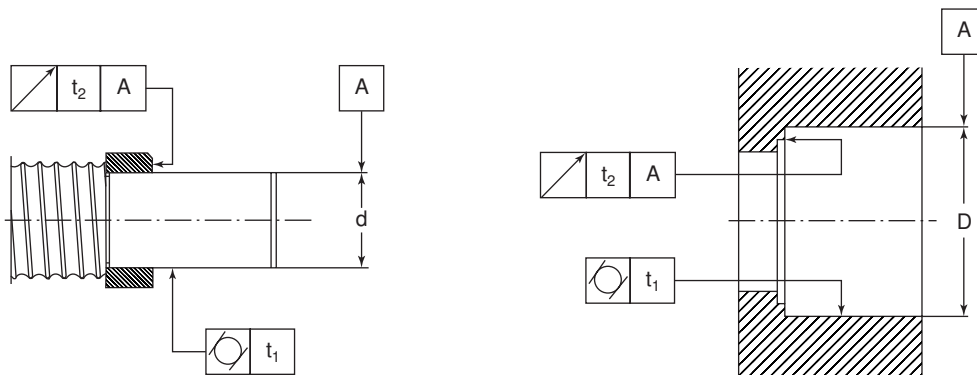

Accuracy of Bearing Seatings on Spindles

Bore diameter d (mm)		Deviations						Tolerances			
		High		Low		Cylindricity runout					
		mm	in	mm	in	t ₁		t ₂			
Over	Incl					mm	in	mm	in		
10	18	.000	.0000	-.005	-.0002	.002	.00008	.002	.00008		
18	30	.000	.0000	-.006	-.00025	.0025	.0001	.0025	.0001		
30	50	.000	.0000	-.007	-.00028	.0025	.0001	.0025	.0001		
50	80	.000	.0000	-.008	-.0003	.003	.00012	.003	.00012		
80	120	.000	.0000	-.010	-.0004	.004	.00015	.004	.00015		

Accuracy of Bearing Seatings in Housing Bore

Outside diameter D (mm)		Deviations				Tolerances			
		Low		High		Cylindricity runout			
		mm	in	mm	in	t ₁		t ₂	
Over	Incl					mm	in	mm	in
—	50	.000	.0000	+.011	+.0004	.0025	.0001	.004	.00015
50	80	.000	.0000	+.013	+.0005	.003	.00012	.005	.0002
80	120	.000	.0000	+.015	+.0006	.004	.00015	.006	.00025
120	150	.000	.0000	+.018	+.0007	.005	.0002	.008	.0003

Design of Bearing Arrangement

The screws are generally supported at both ends in matched bearing sets where the bearings are arranged face-to-face or back-to-back, see drawing on next page. A one-sided support is also commonly used for short screws as illustrated in the lower drawing. Particularly stiff bearing arrangements can be achieved if the screws are mounted in tension between sets of bearings arranged in tandem and adjusted against each other.

If errors of alignment can occur it is recommended that a face-to-face arrangement of the bearings be used, as shown in the bearing arrangement examples. Because the distance between pressure center is shorter for bearings arranged face-to-face than for those arranged back-to-back, errors of alignment can be more easily accommodated.

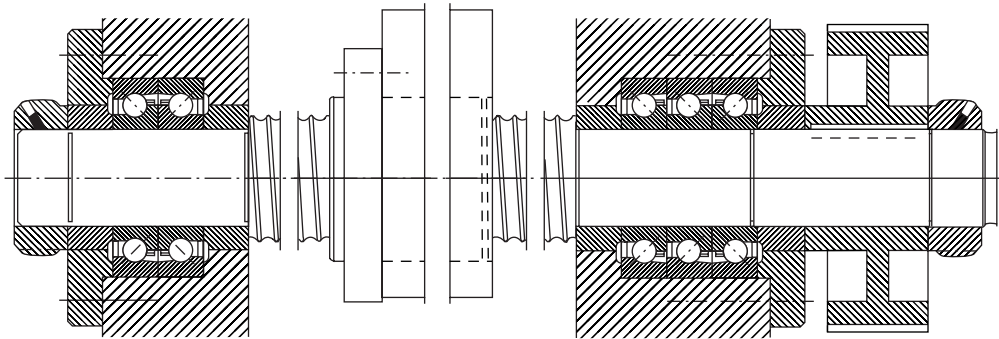

Screw supported at both ends using a set of three bearings arranged in tandem and face-to-face and a set of two bearings arranged face-to-face

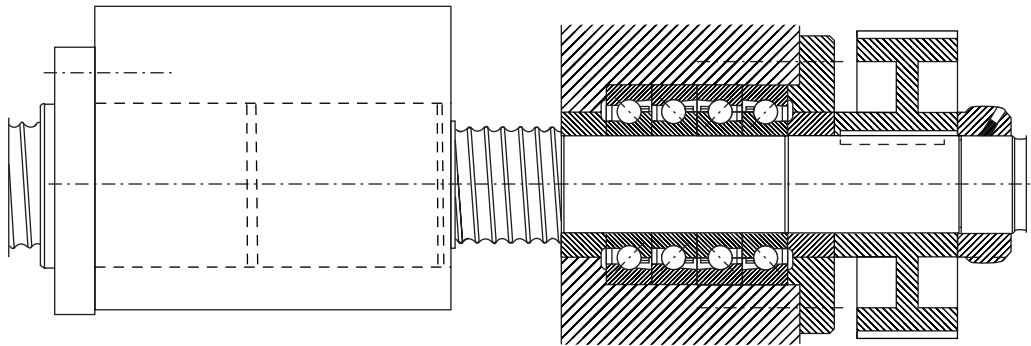

Screw supported at one end using a set of four bearings in a face-to-face arrangement

Lubrication

Ball screw support bearings can be lubricated with either grease or oil. Generally, grease lubrication is preferred as bearing arrangement design can be simple, sealing arrangements uncomplicated and maintenance requirements minimized. Good quality, rust inhibiting lithium base greases of consistency 2 to the NLGI scale with an operating temperature range of -30 to $+110^{\circ}\text{C}$ (-22 to $+230^{\circ}\text{F}$) are suitable. As a rule, a “normal” filling grade (25 to 35% of the free space in the bearing) is recommended; the actual quantities are given in the table on the right.

MRC bearing number	Grease quantity corresponding to percentage of free space (Grams)			
	10-15%	25-35%	45-60%	70-100%
J1232	0.1-0.2	0.3-0.4	0.5-0.7	0.8-1.2
J1535	0.15-0.2	0.35-0.5	0.6-0.9	1.0-1.4
J2047	0.35-0.5	0.9-1.2	1.6-2.1	2.4-3.5
J2552	0.45-0.7	1.1-1.5	2.0-2.6	3.0-4.4
J3062	0.6-0.9	1.4-2.0	2.6-3.5	4.0-5.8
J2047A	0.4-0.6	1.0-1.3	1.7-2.3	2.7-3.8
J2562	0.5-0.8	1.3-1.9	2.4-3.2	3.7-5.3
J3062A	0.5-0.8	1.3-1.9	2.4-3.2	3.7-5.3
J3572	0.6-0.9	1.5-2.1	2.7-3.7	4.3-6.1
J4072	0.6-0.9	1.5-2.1	2.7-3.7	4.3-6.1
J093	0.6-0.9	1.4-2.0	2.6-3.4	4.0-5.7
J175	0.7-1.1	1.8-2.5	3.2-4.3	5.0-7.1

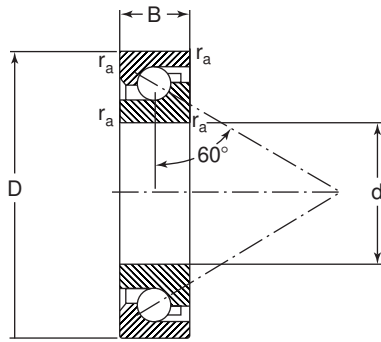

MRC Bearing Number	Bore		Outside Diameter		Width		Fillet ¹⁾ Radius		Basic Radial Load Rating				Maximum Thrust Load		Speed Rating	
	d		D		B		r _a		Dynamic C ²⁾		Static C ₀				Grease	Oil
	mm	in	mm	in	mm	in	mm	in	N	lbf	N	bf	N	lbf	RPM	RPM
J1232	12	.4724	32	1.2598	10	.3937	0.6	.024	11200	2520	15600	3510	7250	1630	12000	16000
J1535	15	.5906	35	1.3780	11	.4331	0.6	.024	12100	2720	18600	4180	8500	1910	11000	15000
J2047	20	.7874	47	1.8504	14	.5512	1.0	.039	21200	4770	35500	7980	19500	4380	8200	11000
J2047A	20	.7874	47	1.8504	15	.5906	1.0	.039	21200	4770	5500	7980	19500	4380	8200	11000
J093	23.838	.9385	61.999	2.4409	15.875	.6250	1.0	.039	32500	7310	58500	13200	36000	8090	6900	9300
J2552	25	.9843	52	2.0472	15	.5906	1.0	.039	21600	4860	38000	8540	20800	4680	7500	10000
J2562	25	.9843	62	2.4409	15	.5906	1.0	.039	32500	7310	58500	13200	36000	8090	7200	9600
J3062	30	1.1811	62	2.4409	16	.6299	1.0	.039	28100	6320	54000	12100	31500	7080	6900	9300
J3062A	30	1.1811	62	2.4409	15	.5906	1.0	.039	28100	6320	54000	12100	31500	7080	7200	9600
J3572	35	1.3780	72	2.8346	15	.5906	1.0	.039	35100	7890	71000	16000	42750	9610	6600	8900
J4072	40	1.5748	72	2.8346	15	.5906	1.0	.039	35100	7890	71000	16000	42750	4270	6600	8900
J175	44.475	1.7510	76.2	3.0000	15.875	.6250	1.0	.039	31200	7010	69500	15600	40200	9040	6300	8400

¹⁾ Fillet radius indicates maximum fillet radius on shaft or in housing which bearing corner will clear.

²⁾ Rating for one million revolutions or 500 hours at 33 1/3 RPM (Rating for single bearing).

Notes

Double Direction Thrust Ball Bearings

Section VI

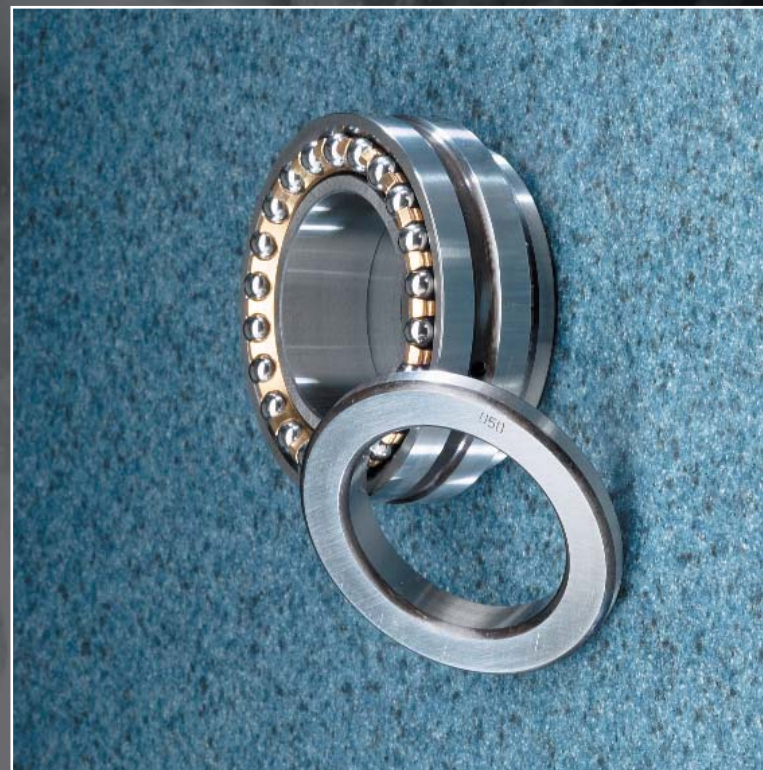

MRC DT100 series double direction angular contact ball bearings are able to locate a spindle axially in both directions and are designed to be used with the NN31X series double row cylindrical roller bearings having the same bore and outside diameter.

The bearings are separable and have a one-piece housing washer, two cages with a large number of balls, and two shaft washers separated by a spacer sleeve. The outside diameter of the housing washer is made to tolerances that result in radial clearance between the washer and housing bore. This is to insure that this bearing will carry only axial loads.

The DT100 series bearings have a 60° contact angle per row and are typically mounted at the side of the cylindrical roller having the smaller inside diameter (tapered bore).

To facilitate lubrication, all bearings have a groove and three lubrication holes in the housing washer.

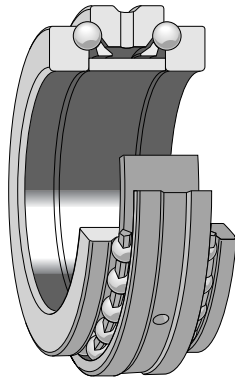

Tolerances

MRC double direction angular contact ball bearings have the same dimensional and running accuracy as the series NN31X cylindrical roller bearings. The tolerances are given in the tables on page 62. The maximum and minimum values listed for single diameters, washer widths and bearing heights, represent the permissible deviations from the nominal dimensions given in the bearing tables.

Symbols

d	nominal bore diameter
d_s	single diameter of bore
D	nominal outside diameter
D_s	single diameter of outside cylindrical surface
C_s	single height (width) of housing washer
S_i, S_e	thickness variation, measured from middle of raceway to back (seating face) of shaft washer and housing washer, respectively
B	single height of bearing

Double Direction Angular Contact Ball Bearings

MRC Machine Tools

Tolerances in Inches (Shaded) and Millimeters

d, D (mm)	Over Incl	18 30	30 50	50 80	80 120	120 150	150 180	180 250	250 315
d _s	MAX	+ .00004 + .001	+ .00004 + .001	+ .00008 + .002	+ .00012 + .003	+ .00012 + .003	+ .00012 + .003	+ .00016 + .004	—
	MIN	— - .00035 - .009	— - .00043 - .011	— - .00055 - .014	— - .0007 - .018	— - .0008 - .021	— - .0008 - .021	— - .0010 - .026	—
D _s	MAX	—	- .0008 - .020	- .0009 - .024	- .0011 - .028	- .0013 - .033	- .0013 - .033	- .0015 - .037	- .0016 - .041
	MIN	—	- .0011 - .027	- .0013 - .033	- .0015 - .038	- .0017 - .044	- .0018 - .046	- .0020 - .052	- .0023 - .059
B	MAX	+ .0020 + .050	+ .0024 + .060	+ .0028 + .070	+ .0033 + .085	+ .0037 + .095	+ .0037 + .095	+ .0047 + .120	—
	MIN	— - .0031 - .080	— - .0039 - .100	— - .0047 - .120	— - .0055 - .140	— - .0063 - .160	— - .0063 - .160	— - .0079 - .200	—
S _i , S _e	MAX	.00012 .003	.00012 .003	.00016 .004	.00016 .004	.0002 .005	.0002 .005	.0002 .005	—
CS	MAX	—	.000 - .0024	.000 - .0024	.000 - .0024	.000 - .0024	.000 - .0024	.000 - .0024	.000 - .0024
	MIN	—	- .060	- .060	- .060	- .060	- .060	- .060	- .060

Preload

MRC double direction angular contact bearings are supplied with a preload as specified in table below.

The values quoted in the table apply to bearings before mounting. When mounted, the bearings may have a higher preload, depending on the shaft tolerance selected.

Bore diameter mm	Axial preload		Bore diameter mm	Axial preload	
	N	lbf		N	lbf
40	360	81	100	690	155
45	390	88	105	710	160
50	415	93	110	735	165
55	440	99	120	800	180
60	470	106	130	870	196
65	490	110	140	940	211
70	515	116	150	1015	228
75	545	123	160	1100	247
80	575	129	170	1185	266
85	600	135	180	1290	290
90	625	141	190	1385	311
95	655	147	200	1525	343

Cages

Depending on the bearing size, the cages are either machined brass or heat stabilized glass reinforced polyamide, ball centered. Either material can be used at operating temperatures up to 120°C (248°F). Cage properties are not affected by the lubricants normally used with the exception of some synthetic oils and greases with a synthetic oil base.

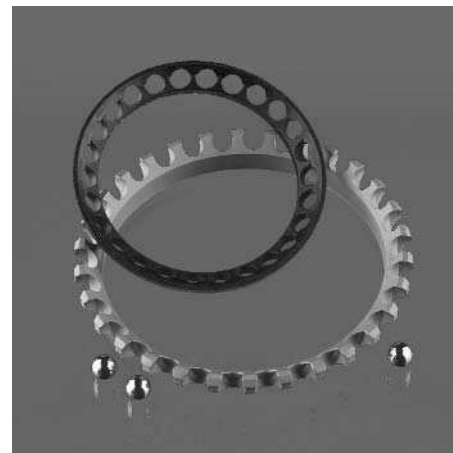

Cages for double direction angular contact ball bearings

Accuracy of Bearing Seatings on Spindles

Bore diameter d (mm)		Deviations						Tolerances			
		High		Low		Cylindricity runout					
		mm	in	mm	in	t ₁		t ₂			
Over	Incl					mm	in	mm	in		
40	50	.000	.0000	-.007	-.00028	.0025	.0001	.0025	.0001		
50	80	.000	.0000	-.008	-.0003	.003	.00012	.003	.00012		
80	120	.000	.0000	-.010	-.0004	.004	.00015	.004	.00015		
120	180	.000	.0000	-.012	-.0005	.0045	.0002	.0045	.0002		
180	250	.000	.0000	-.014	-.0006	.0050	.0002	.0050	.0002		

Accuracy of Bearing Seatings in Housing Bore

Outside diameter D (mm)		Deviations			
		Low		High	
		mm	in	mm	in
Over	Incl				
50	80	-.010	-.0004	+.003	+.0001
80	120	-.013	-.0005	+.002	+.0001
120	180	-.015	-.0006	+.003	+.0001
180	250	-.018	-.0007	+.002	+.0001
250	315	-.020	-.0008	+.003	+.0001

Design of Bearing Arrangement

Double direction angular contact ball bearings are mounted with radial clearance in the same housing bore seating as the appropriate cylindrical roller bearing. Fits tighter than those recommended should never be used even if they are required for the cylindrical roller bearing.

Double Direction Angular Contact Ball Bearings

MRC Machine Tools

Equivalent Dynamic and Static Bearing Loads

For double direction angular contact ball bearings subjected to thrust loads only, the equivalent radial load is as follows:

$$\begin{array}{ll} \text{Dynamic} & P = F_A \\ \text{Static} & P_0 = F_A \end{array}$$

where, F_A = applied thrust load.

Mounting Instructions

When mounting double direction angular contact ball bearings, care should be taken not to mix the components of one bearing with those of other bearings.

Care should be exercised in applying axial force since the spacer sleeve could be deformed resulting in excessive preload and increased temperature, causing shortened bearing life. Suitable values for axial force to be applied range from (80 N to 200 N) d, or (18 lbf to 45 lbf) d (d = bearing bore in mm).

Typical mounting arrangement is shown below.

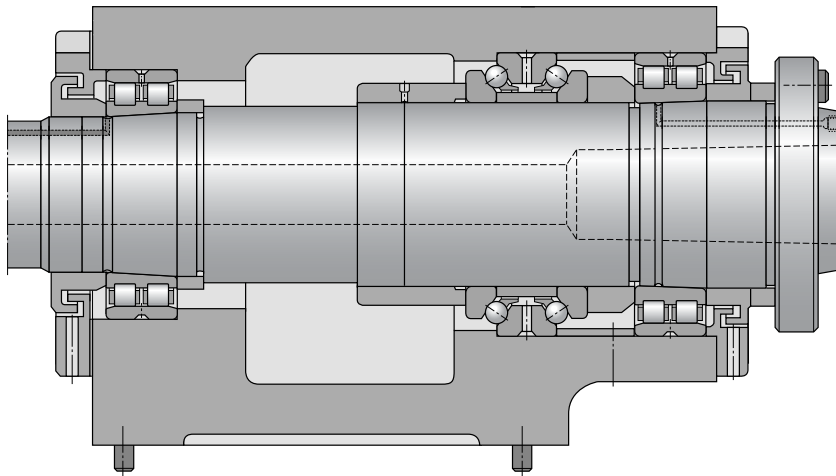

Two NN31X series double row cylindrical roller bearings and one double direction angular contact ball bearing.

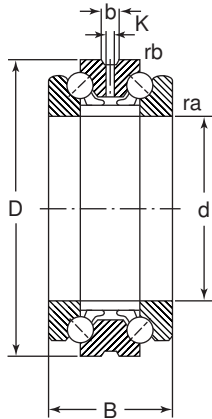

MRC bearing number	Bore d		Outside diameter D		Width B		Fillet radius ¹⁾				Basic radial load rating				Speed rating					
							r _a		r _b		K		b		Dynamic C ₂ ²⁾		Static C ₀		Grease RPM	Oil RPM
	mm	in	mm	in	mm	in	mm	in	mm	in	mm	in	mm	in	N	lbf	N	lbf		
DT108	40	1.5748	68	2.6772	36	1.4173	1.0	.039	0.1	.004	3.0	.12	5.5	.22	21600	4860	60000	13500	9500	12000
DT109	45	1.7717	75	2.9528	38	1.4961	1.0	.039	0.1	.004	3.0	.12	5.5	.22	24700	5550	71000	16000	9000	11000
DT110	50	1.9685	80	3.1496	38	1.4961	1.0	.039	0.1	.004	3.0	.12	5.5	.22	25500	5730	78000	17500	8500	10000
DT111	55	2.1654	90	3.5433	44	1.7323	1.0	.039	0.3	.012	3.0	.12	5.5	.22	33800	7600	104000	23400	7000	8500
DT112	60	2.3622	95	3.7402	44	1.7323	1.0	.039	0.3	.012	3.0	.12	5.5	.22	34500	7760	108000	24300	7000	8500
DT113	65	2.5591	100	3.9370	44	1.7323	1.0	.039	0.3	.012	3.0	.12	5.5	.22	35800	8050	116000	26100	6700	8000
DT114	70	2.7559	110	4.3307	48	1.8898	1.0	.039	0.3	.012	3.0	.12	5.5	.22	43600	9800	143000	32100	6300	7500
DT115	75	2.9528	115	4.5276	48	1.8898	1.0	.039	0.3	.012	3.0	.12	5.5	.22	44200	9940	150000	33700	6000	7000
DT116	80	3.1496	125	4.9213	54	2.1260	1.0	.039	0.3	.012	4.5	.18	8.3	.33	54000	12100	180000	40500	5300	6300
DT117	85	3.3465	130	5.1181	54	2.1260	1.0	.039	0.3	.012	4.5	.18	8.3	.33	54000	12100	190000	42700	5300	6300
DT118	90	3.5433	140	5.5118	60	2.3622	1.5	.059	0.3	.012	4.5	.18	8.3	.33	62400	14000	220000	49500	4800	5600
DT119	95	3.7402	145	5.7087	60	2.3622	1.5	.059	0.3	.012	4.5	.18	8.3	.33	63700	14300	232000	52200	4800	5600
DT120	100	3.9370	150	5.9055	60	2.3622	1.5	.059	0.3	.012	4.5	.18	8.3	.33	66300	14900	245000	55100	4800	5600
DT121	105	4.1339	160	6.2992	66	2.5984	2.0	.079	0.6	.024	4.5	.18	8.3	.33	74100	16700	275000	61800	4300	5000
DT122	110	4.3307	170	6.6929	72	2.8346	2.0	.079	0.6	.024	4.5	.18	8.3	.33	92300	20700	335000	75300	4000	4800
DT124	120	4.7244	180	7.0866	72	2.8346	2.0	.079	0.6	.024	4.5	.18	8.3	.33	93600	21000	360000	80900	3800	4500
DT126	130	5.1181	200	7.8740	84	3.3071	2.0	.079	0.6	.024	6.0	.24	11.1	.44	117000	26300	455000	102000	3400	4000
DT128	140	5.5118	210	8.2677	84	3.3071	2.0	.079	0.6	.024	6.0	.24	11.1	.44	117000	26300	475000	107000	3200	3800
DT130	150	5.9055	225	8.8583	90	3.5433	2.0	.079	0.6	.024	7.5	.30	13.9	.55	140000	31500	570000	128000	3000	3600
DT132	160	6.2992	240	9.4488	96	3.7795	2.0	.079	0.6	.024	7.5	.30	13.9	.55	156000	35100	640000	144000	2800	3400
DT134	170	6.6929	260	10.2362	108	4.2520	2.0	.079	0.6	.024	7.5	.30	13.9	.55	195000	43800	780000	175000	2400	3000
DT136	180	7.0866	280	11.0236	120	4.7244	2.0	.079	0.6	.024	9.0	.35	16.7	.66	225000	50600	915000	206000	2000	2600
DT138	190	7.4803	290	11.4173	120	4.7244	2.0	.079	0.6	.024	9.0	.35	16.7	.66	225000	50600	950000	214000	2000	2600
DT140	200	7.8740	310	12.2047	132	5.1968	2.0	.079	0.6	.024	9.0	.35	16.7	.66	265000	59600	1100000	247000	1900	2400

¹⁾ Fillet radius indicates maximum fillet radius on shaft or in housing which bearing corner will clear.

²⁾ Rating for one million revolutions or 500 hours at 33 1/3 RPM.

Precision Ground Ball Screws

Section VII



To make the very best selection of a ball screw, it is necessary to identify critical parameters such as the load profile, linear or rotational speed, rate of acceleration or deceleration, cycle rate, environment, required life, lead accuracy, stiffness, and any other special requirement. These factors are defined in the following paragraphs and can be calculated by using the formulas on pages 99 through 101. Should any assistance be required in the selection, please contact MRC.

Basic Dynamic Load Rating (C_a)

The dynamic rating is used to compute the fatigue life of ball screws. It is the axial load constant in magnitude and direction, and acting centrally under which the nominal life (as defined by ISO) reaches one million revolutions.

Nominal Fatigue Life L_{10}

The nominal life of a ball screw is the number of revolutions (or the number of operating hours at a given constant speed) which the ball screw is capable of enduring before the first sign of fatigue (flaking, spalling) occurs on one of the rolling surfaces.

It is however evident from both laboratory tests and practical experience that seemingly identical ball screws operating under identical conditions have different lives, hence the notion of **nominal life**. It is, in accordance with ISO definition, the life achieved or exceeded by 90% of a sufficiently large group of apparently identical ball screws, working in identical conditions (alignment, axial and centrally applied load, speed, acceleration, lubrication, temperature and cleanliness).

Service Life

The actual life achieved by a specific ball screw before it fails is known as “service life”. Failure is generally by wear, not by fatigue (flaking or spalling); wear of the recirculation system, corrosion, contamination, and, more generally, by loss of the functional characteristics required by the application. Experience acquired with similar applications will help to select the proper screw to obtain the required service life. One must also take into account structural requirements such as the strength of screw ends and nut attachments, due to the loads applied on these elements in service.

¹MRC can help you define this value in relation with the actual conditions of service.

Equivalent Dynamic Loads

The loads acting on the screw can be calculated according to the laws of mechanics if the external forces (e.g. power transmission, work, rotary and linear inertia forces) are known or can be calculated. It is necessary to calculate the equivalent dynamic load: this load is defined as that hypothetical load, constant in magnitude and direction, acting axially and centrally on the screw which, if applied, would have the same influence on the screw life as the actual loads to which the screw is subjected.

Radial and moment loads must be taken by linear bearing systems. It is extremely important to resolve these problems **at the earliest conceptual stage**. These forces are detrimental to the life and the expected performance of the screw.

Fluctuating load

When the load fluctuates during the working cycle, it is necessary to calculate the equivalent dynamic load: this load is defined as that hypothetical load, constant in magnitude and direction, acting axially and centrally on the screw which, if applied, would have the same influence on the screw life as the actual loads to which the screw is subjected. Additional loads due, for example, to misalignment, uneven loading, shocks, and so on, must be taken into account. Their influence on the nominal life of the screw is generally taken care of; consult MRC for advice.

Static Load Carrying Capacity (C_{0a})

Ball screws should be selected on the basis of the basic static load rating C_{0a} instead of on bearing life when they are subjected to continuous or intermittent shock loads, while stationary or rotating at very low speed for short duration. The permissible load is determined by the permanent deformation caused by the load acting at the contact points. It is defined by ISO standards as the purely axially and centrally applied static load which will create, by calculation, a total (rolling element + thread surface) permanent deformation equal to .0001 of the diameter of the rolling element. A ball screw must be selected by its basic static load rating which must be, at least, equal to the product of the maximum axial static load applied and a safety factor “ s_o .” The safety factor is selected in relation with past experience of similar applications and requirements of running smoothness and noise level¹.

Critical Rotating Speed for Screw Shafts

The shaft is equated to a cylinder, the diameter of which is the root diameter of the thread. The formulae use a parameter the value of which is dictated by the mounting of the screw shaft (whether it is simply supported or fixed). As a rule, the nut is not considered as a support of the screw shaft. Because of the potential inaccuracies in the mounting of the screw assembly, a safety factor of .80 is applied to the calculated critical speeds.

Calculations that consider the nut as a support of the shaft, or reduce the safety factor, require practical tests and possibly an optimization of the design.¹

Permissible Speed Limit

The permissible speed limit is that speed which a screw cannot reliably exceed at any time. It is generally the limiting speed of the recirculation system in the nut. It is expressed as the product of the rpm and the nominal diameter of the screw shaft (in mm). The speed limits quoted in this catalog are **the maximum speeds that may be applied through very short periods** and in optimized running conditions of alignment, light external load and preload with monitored lubrication. Running a screw continuously at the permissible speed limit may lead to a reduction of the calculated life of the nut mechanism.

High speed associated with high load requires a large input torque and yields a relatively short nominal life.¹ In the case of high acceleration and deceleration, it is recommended to either work under a nominal external load or to apply a light preload to the nut to avoid internal sliding during reversal. The value of preload of screws submitted to high velocity must be that preload which ensures that the rolling elements do not slide.¹

Too-high a preload will create unacceptable increases of the internal temperature.

The lubrication of screws rotating at high speed must be properly considered in quantity and quality. The volume, spread and frequency of the application of the lubricant (oil or grease), must be properly selected and monitored. At high speed the lubricant spread on the surface of the screw shaft may be thrown off by centrifugal forces. It is important to monitor this phenomenon during the first run at high speed and possibly adapt the frequency of re-lubrication or the flow of lubricant, or select a lubricant with a different viscosity. Monitoring the steady temperature reached by the nut permits the frequency of re-lubrication or the oil flow rate to be optimized.

Efficiency and Back-Driving

The performance of a screw is mainly dependent on the geometry of the contact surfaces and their finish as well as the helix angle of the thread. It is, also, dependent on the working conditions of the screw (load, speed, lubrication, preload, alignment etc.).

The “**direct efficiency**” is used to define the input torque required to transform the rotation of one member into the translation of the other. Conversely, the “**indirect efficiency**” is used to define the axial load required to transform the translation of one member into the rotation of the other one. It is used, also, to define the braking torque required to prevent that rotation.

It is safe to consider that these screws are reversible or back-driveable under almost all circumstances.

It is therefore necessary to design a brake mechanism if back-driving is to be avoided (gear reducers or brake).

Preload torque:

Internally preloaded screws exhibit a torque due to this preload. This persists even when they are not externally loaded. Preload torque is measured at 50 RPM when assembly is lubricated with ISO grade 64 oil.

Starting torque:

This is defined as the torque needed to overcome the following to start rotation:

- the total inertia of all moving parts accelerated by the energy source (including rotation and linear movement).
- the internal friction of the screw/nut assembly, bearing and associated guiding devices.

In general, torque to overcome inertia (a) is greater than friction torque (b).

The coefficient of friction of the high efficiency screw when starting μ_s is estimated at up to double the dynamic coefficient μ , under normal conditions of use.

Axial Play and Preload

Preloaded nuts are subject to much less elastic deformation than non-preloaded nuts. Therefore they should be used whenever the accuracy of positioning under load is important.

¹MRC can help you define this value in relation with the actual conditions of service.

Preload is that force applied to a set of two half nuts to either press them together or push them apart with the purpose of eliminating backlash or increasing the rigidity or stiffness of the assembly. The preload is defined by the value of the preload torque (see under that heading in the previous paragraph). The torque depends on the type of nut and on the mode of preload (elastic or rigid).

Static Axial Stiffness of a Complete Assembly

It is the ratio of the external axial load applied to the system and the axial displacement of the face of the nut in relation with the fixed (anchored) end of the screw shaft. The inverse of the *rigidity of the total system* is equal to the sum of all the inverses of the rigidity of each of the components (screw shaft, nut as mounted on the shaft, supporting bearing, supporting housings, etc.). Because of this, the rigidity of the total system is always less than the smallest individual rigidity.

Nut Rigidity

When a preload is applied to a nut, firstly, the internal play is eliminated, then, the Hertzian elastic deformation increases as the preload is applied so that the overall rigidity increases. The theoretical deformation does not take into account machining inaccuracies, actual sharing of the load between the different contact surfaces, the elasticity of the nut and of the screw shaft. The practical stiffness values given in the catalog are lower than the theoretical values for this reason. The rigidity values given in the catalog are individual practical values for the assembled nut. They are determined by the value of the selected basic preload and an external load equal to twice this preload.

Elastic Deformation of Screw Shaft

This deformation is proportional to its length and inversely proportional to the square of the root diameter. According to the relative importance of the screw deformation (see rigidity of the total system), too large an increase in the preload of the nut and supporting bearings yields a limited increase of rigidity and notably increases the preload torque and therefore the running temperature. Consequently, the preload stated in the catalog for each dimension is optimum and should not be increased.

Screw Shaft Buckling

The column loading of the screw shaft must be checked when it is submitted to compression loading (whether dynamically or statically). The maximum permissible compressive load is calculated using the Euler formula. It is then multiplied by a safety factor of 3 to 5, depending on the application.

The type of end mounting of the shaft is critical to select the proper coefficients to be used in the Euler formulas.

When the screw shaft comprises a single diameter, the root diameter is used for the calculation. When the screw comprises different sections with various diameters, calculations become more complex¹.

Manufacturing Precision

Generally speaking, the precision indication given in the designation defines the lead precision; see page 73—lead precision according to ISO—(ex. G5-G3 . . .).

Parameters other than lead precision correspond to our internal standards (generally based on ISO class 5).

If you require special tolerances (for example, class 5) please specify when requesting a quotation or ordering.

Materials and Heat Treatments

Standard screw shafts are machined from steel which is surface hardened by induction (C48 or equivalent).

Standard nuts are machined in steel which is carburized and through hardened (18 Ni CrMo5 or equivalent). Hardness of the contact surfaces is 59-62 HRC, depending on diameter, for standard screws.

Number of Circuits of Balls

A nut is defined by the number of ball turns which support the load. The number is changing, according to the product and the combination diameter/lead.

It is defined by the number of circuits and their type.

Working Environment

Our products have not been developed for use in an explosive atmosphere, consequently we cannot take any responsibility for the use in this field.

NOTE: 42 CrMo, an AFNOR reference is similar to AISI 4140; 100Cr6 is similar to AISI 52100.

¹MRC can help you define this value in relation with the actual conditions of service.

Ground ball screws are precision components and should be handled with care to avoid shocks. When stored out of the shipping crate they must lie on wooden or plastic vee blocks and should not be allowed to sag.

Screw assemblies are shipped, wrapped in a heavy gauge plastic tube which protects them from foreign material and possible pollution. They should stay wrapped until they are used.

Radial and Moment Loads

Any radial or moment load on the nut will overload some of the contact surfaces, thus significantly reducing its life.

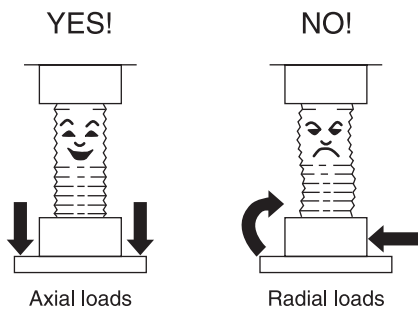

Alignment

MRC linear guidance components should be used to ensure correct alignment and avoid non-axial loading. The parallelism of the screw shaft with the guiding devices must be checked. If external linear guidance proves impractical, we suggest mounting the nut on trunnions or gimbals and the screw shaft in self-aligning bearings.

Mounting the screw in tension helps align it properly and eliminates bucking.

Lubrication

Good lubrication is essential for the proper functioning of the screw and for its long term reliability¹.

Before shipping, the screw is coated with a protective fluid that dries to a film. ***This protective film is not a lubricant.***

Depending on the selected lubricant, it may be necessary to remove this film before applying the lubricant (there may be a risk of non-compatibility).

If this operation is performed in a potentially polluted atmosphere it is highly recommended to proceed with a thorough cleaning of the assembly.

Designing the Screw Shaft Ends

Generally speaking, when the ends of the screw shaft are specified by the customer's engineering personnel, it is their responsibility to check the strength of these ends. However, we offer on pages 86 and 87 of this catalog, a choice of standard machined ends. As far as possible, we recommend their use.

Whatever your choice may be, please keep in mind that no dimension on the shaft ends can exceed d_o (otherwise traces of the root of thread will appear or the shaft must be made by joining 2 pieces).

A minimum shoulder should be sufficient to maintain the internal bearing.

Starting-Up the Screw

After the assembly has been cleaned, mounted and lubricated, it is recommended that the nut is allowed to make several full strokes at low speed; to check the proper positioning of the limit switches or reversing mechanism before applying the full load and the full speed.

Operating Temperature

Screws made from standard steel and operating under normal loads can sustain temperatures in the range minus 20° to +100°C (-4° to + 212°F).

Above 100°C (212°F), steels adapted to the temperature of the application should be selected.

Consult MRC for advice.

NOTE: Operating at high temperature will lower the hardness of the steel, alter the accuracy of the thread and may increase the oxidability of the materials.

¹MRC can help you define this value in relation with the actual conditions of service.

Lead precision is measured at 20°C (68°F) on the useful stroke l_u , which is the threaded length decreased, at each end, by the length l_e equal to the screw shaft diameter.

$V_{300p, \mu m}$	G1		G3		G5	
	6		12		23	
l_u mm	e_p μm	v_{up}	e_p	v_{up}	e_p	v_{up}
0–315	6	6	12	12	23	23
(315)–400	7	6	13	12	25	25
(400)–500	8	7	15	13	27	26
(500)–630	9	7	16	14	32	29
(630)–800	10	8	18	16	36	31
(800)–1000	11	9	21	17	40	34
(1000)–1250	13	10	24	19	47	39
(1250)–1600	15	11	29	22	55	44
(1600)–2000			35	25	65	51
(2000)–2500			41	29	78	59
(2500)–3150					96	69
(3150)–4000					115	82

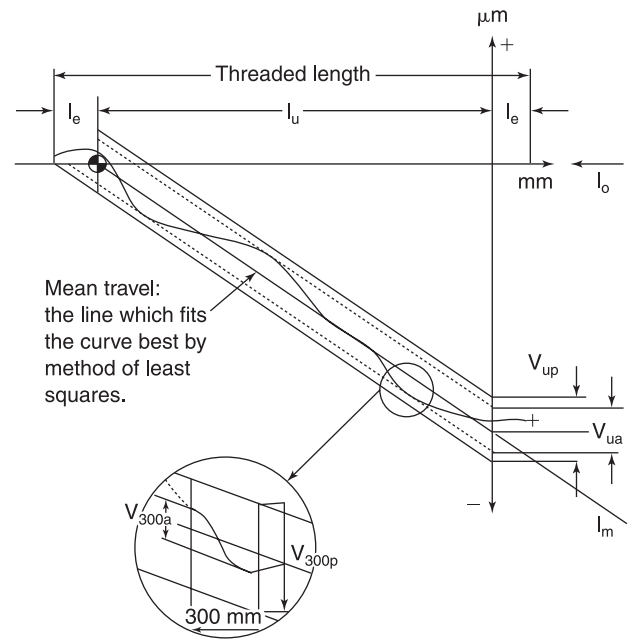

- l_u = useful travel
- l_e = excess travel (no lead precision required)
- l_o = nominal travel
- l_s = specified travel
- c = travel compensation (difference between l_s and l_o to be defined by the customer, for instance to compensate an expansion)
- e_p = tolerance over the specified travel

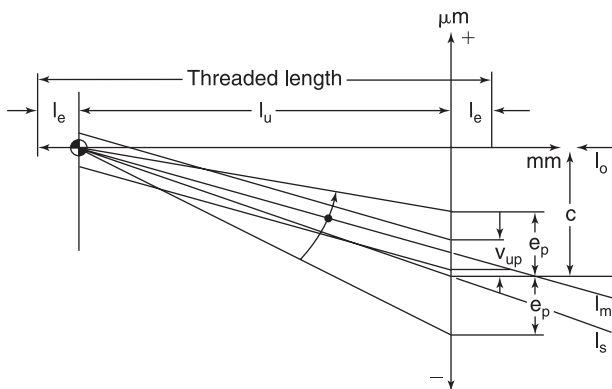

Case with value of c specified by the customer

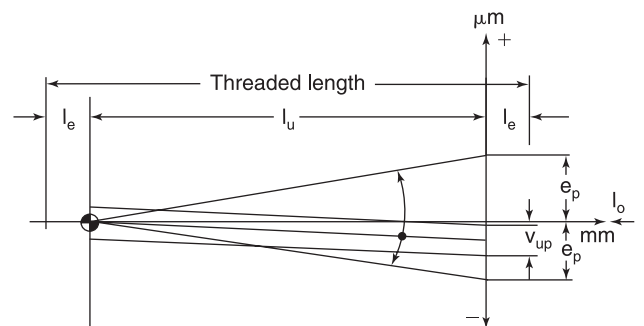

Case with $c = 0$ = standard version in case of no value given by the customer.

- V = travel variation (or permissible band width)
- V_{300p} = maximum permitted travel variation over 300 mm
- V_{up} = maximum permitted travel variation over the useful travel l_u
- V_{300a} = measured travel variation over 300 mm
- V_{ua} = measured travel variation over the useful travel

PGFJ Flanged Nut With Internal Preload

MRC Machine Tools

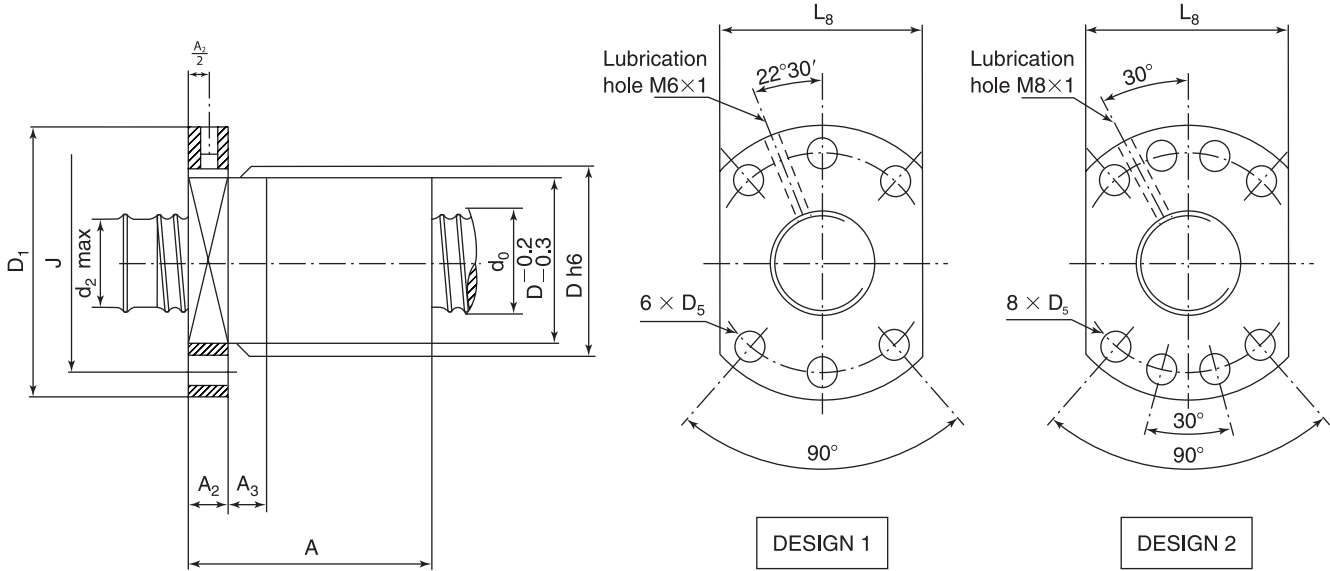

Designation	Screw Diameter d_0		Lead P_h		Number of Circuits of Balls	Basic Load Ratings				Preload Torque T_{pe}		Nut Stiffness R_n	
						Dynamic C_a		Static C_{oa}					
	mm	in	mm	in		kN	lbf	kN	lbf	Nm	lbf-ft	daN/ μm	lbf/ μm^1
PGFJ16X5	16	.6300	5	.20	3 × 2	9.7	2180	14.2	3190	.05	.037	49	110
PGFJ20X5	20	.7874	5	.20	3 × 2	13.4	3010	24.5	5510	.08	.059	78	175
PGFJ25X5	25	.9843	5	.20	3 × 2	15.6	3510	33.6	7550	.12	.090	102	229
PGFJ25X10	25	.9843	10	.39	3 × 2	20.2	4540	39.5	8880	.16	.12	98	220
PGFJ32X5	32	1.2598	5	.20	4 × 2	22.1	4970	57	12800	.22	.16	158	355
PGFJ32X10	32	1.2598	10	.39	3 × 2	42.2	9490	80	18000	.43	.32	130	292
PGFJ40X5	40	1.5748	5	.20	4 × 2	24.6	5530	73	16400	.30	.22	192	432
PGFJ40X10	40	1.5748	10	.39	4 × 2	59.6	13400	130	29200	.75	.55	186	418
PGFJ50X5	50	1.9685	5	.20	4 × 2	27.2	6110	93	20900	.41	.30	244	549
PGFJ50X10	50	1.9685	10	.39	4 × 2	68	15300	170	38200	1.06	.78	242	544
PGFJ63X5	63	2.4803	5	.20	4 × 2	30	6740	120	27000	.58	.43	280	629
PGFJ63X10	63	2.4803	10	.39	4 × 2	77.5	17400	227	51000	1.51	1.11	292	656
PGFJ80X10	80	3.1496	10	.39	4 × 2	86	19300	293	65900	2.12	1.56	369	830

¹⁾ One micron (μm) equals .0000394 inches.

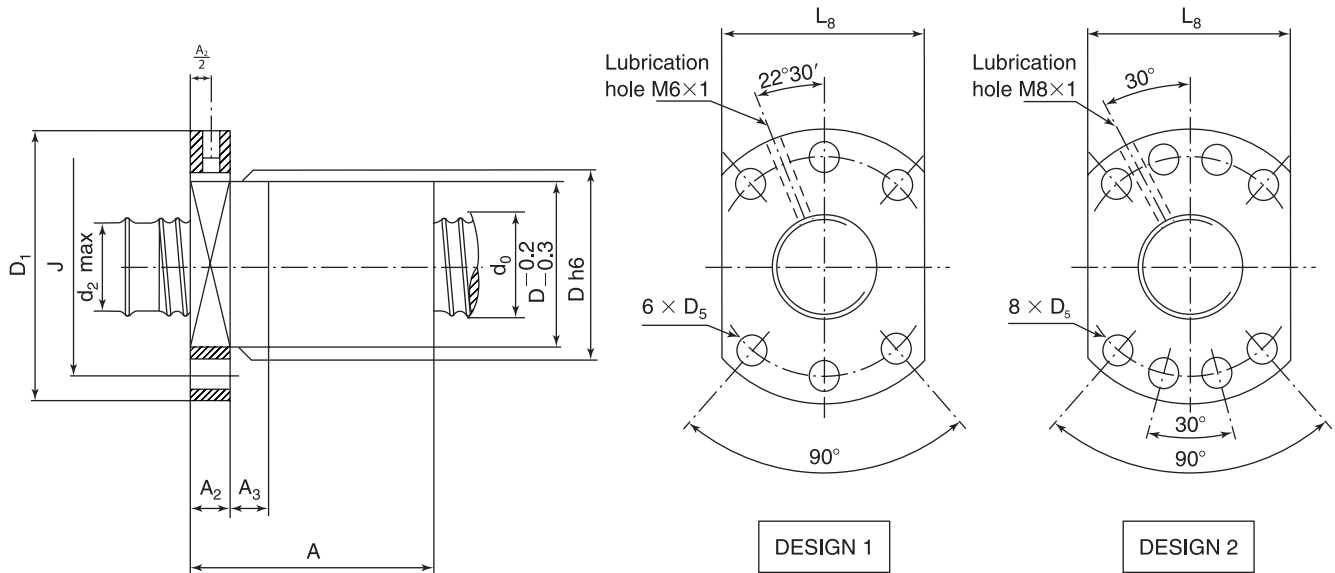

MRC Number	d ₂		D		J		Design	D ₅		D ₁		A		A ₃		A ₂		L ₈	
	mm	in	mm	in ²⁾	mm	in		mm	in	mm	in	mm	in	mm	in	mm	in	mm	in
PGFJ16X5	13.2	.52	28	1.102	38	1.50	1	5.5	.217	48	1.89	63	2.48	10	.39	12	.47	40	1.57
PGFJ20X5	17.2	.68	36	1.417	47	1.85	1	6.6	.260	58	2.28	65	2.56	10	.39	12	.47	44	1.73
PGFJ25X5	22.2	.87	40	1.575	51	2.01	1	6.6	.260	62	2.44	68	2.68	10	.39	14	.55	48	1.89
PGFJ25X10	21.6	.85	40	1.575	51	2.01	1	6.6	.260	62	2.44	104	4.09	10	.39	15	.55	48	1.89
PGFJ32X5	29.2	1.15	50	1.969	65	2.56	1	9	.354	80	3.15	81	3.19	10	.39	15	.55	62	2.44
PGFJ32X10	26.7	1.05	50	1.969	65	2.56	1	9	.354	80	3.15	117	4.61	16	.63	18	.71	62	2.44
PGFJ40X5	37.2	1.46	63	2.480	78	3.07	2	9	.354	93	3.66	82	3.23	10	.39	16	.63	70	2.76
PGFJ40X10	34.7	1.37	63	2.480	78	3.07	2	9	.354	93	3.66	142	5.59	16	.63	18	.71	70	2.76
PGFJ50X5	47.2	1.86	75	2.953	93	3.66	2	11	.433	110	4.33	82	3.23	10	.39	16	.63	85	3.35
PGFJ50X10	44.7	1.76	75	2.953	93	3.66	2	11	.433	110	4.33	144	5.67	16	.63	20	.79	85	3.35
PGFJ63X5	60.2	2.37	90	3.543	108	4.25	2	11	.433	125	4.92	84	3.31	10	.39	18	.71	95	3.74
PGFJ63X10	57.7	2.27	90	3.543	108	4.25	2	11	.433	125	4.92	147	5.79	16	.63	22	.87	95	3.74
PGFJ80X10	74.7	2.94	105	4.134	125	4.92	2	13.5	.531	145	5.71	150	5.91	16	.63	24	.94	110	4.33

²⁾ Inch dimension tolerance –.008, –.012.

PGFJ Double Preloaded Flanged Nut

MRC Machine Tools

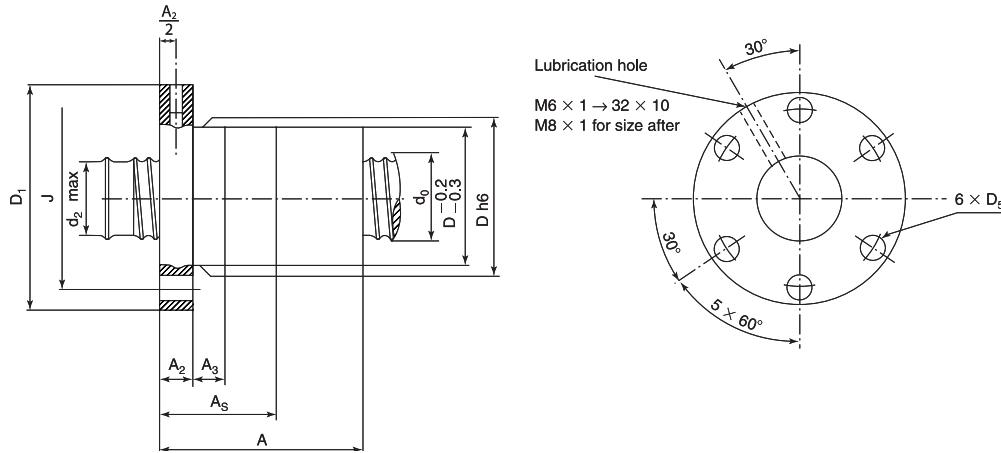

Designation	Screw Diameter d_0		Lead P_h		Number of Circuits of Balls	Basic Load Ratings				Preload Torque T_{pe}		Nut Stiffness R_n	
						Dynamic C_a		Static C_{oa}					
	mm	in	mm	in		kN	lbf	kN	lbf	Nm	lbf-ft	daN/ μm	lbf/ μm^1
PGFL16X5	16	.6299	5	.20	3	9.7	2180	14.2	3190	.05	.037	49	110
PGFL20X5	20	.7874	5	.20	3	13.4	3010	24.5	5510	.08	.059	78	175
PGFL25X2	25	.9843	2	.08	4	7.8	1750	23	5170	.06	.044	60	135
PGFL25X4	25	.9843	4	.16	4	14.4	3240	35	7870	.11	.081	120	270
PGFL25X5	25	.9843	5	.20	3	15.6	3510	33.6	7550	.12	.089	102	229
PGFL25X6	25	.9843	6	.24	3	20.7	4650	40.5	9100	.16	.12	100	225
PGFL25X10	25	.9843	10	.40	3	20.2	4540	39.5	8880	.16	.12	98	220
PGFL32X4	32	1.2598	4	.16	4	16.5	3710	48	10800	.16	.12	140	315
PGFL32X5	32	1.2598	5	.20	3	17.3	3890	42.8	9620	.17	.13	120	270
PGFL32X5	32	1.2598	5	.20	4	22.1	4970	57	12800	.22	.16	153	344
PGFL32X6	32	1.2598	6	.24	3	23.3	5240	52.5	11800	.23	.17	124	279
PGFL32X8	32	1.2598	8	.31	3	29.5	6630	62	13900	.30	.22	128	288
PGFL32X10	32	1.2598	10	.40	3	42.2	9490	80	18000	.43	.32	130	292
PGFL32X20	32	1.2598	20	.79	2.75	30	6740	60	13500	.30	.22	90	202
PGFL32X25	32	1.2598	25	.98	2.75	29	6520	60	13500	.36	.27	90	202
PGFL32X32	32	1.2598	32	1.26	1.75	19.4	4360	41.8	9400	.19	.14	60	135
PGFL40X5	40	1.5748	5	.20	4	24.6	5530	73	16400	.30	.22	192	432
PGFL40X6	40	1.5748	6	.24	3	25.8	5800	66.9	15000	.32	.24	113	254
PGFL40X6	40	1.5748	6	.24	4	33.1	7440	89	20000	.41	.30	145	326
PGFL40X8	40	1.5748	8	.31	3	33	7420	79	17800	.41	.30	145	326
PGFL40X10	40	1.5748	10	.40	3	46.5	10500	98	22000	.59	.44	148	333
PGFL40X10	40	1.5748	10	.40	4	59.6	13400	130	29200	.75	.55	186	418
PGFL40X12	40	1.5748	12	.47	3	53.9	12100	109	24500	.69	.51	150	337
PGFL40X20	40	1.5748	20	.79	3	46	10300	98	22000	.59	.44	147	330
PGFL40X40	40	1.5748	40	1.57	1.75	30.9	6950	68.4	15400	.42	.31	90	202
PGFL50X5	50	1.9685	5	.20	4	27.2	6110	93	20900	.41	.30	244	549
PGFL50X6	50	1.9685	6	.24	4	37	8310	114	25600	.57	.42	254	571
PGFL50X10	50	1.9685	10	.40	3	53	11900	128	28800	.82	.60	189	425
PGFL50X10	50	1.9685	10	.40	4	68	15300	170	38200	1.06	.78	242	544
PGFL50X12	50	1.9685	12	.47	3	62.8	14100	147	33000	.99	.73	170	382

¹⁾ One micron (μm) equals .0000394 inches.

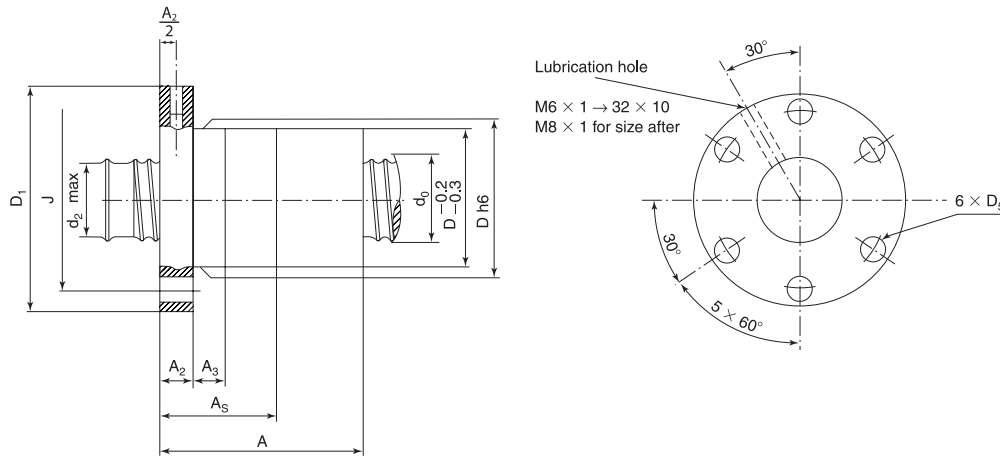

Designation	d ₂		D		J		D ₅		D ₁		A Dbl Nut		A ₅ Sgle Nut		A ₃		A ₂	
	mm	in	mm	in ²	mm	in	mm	in	mm	in	mm	in	mm	in	mm	in	mm	in
PGFL16X5	13.2	.52	28	1.102	38	1.50	5.5	.217	52	2.05	79	3.11	45.5	1.79	10	.39	12	.47
PGFL20X5	17.2	.68	36	1.417	47	1.85	6.5	.256	61	2.40	79	3.11	45.5	1.79	10	.39	12	.47
PGFL25X2	23.8	.94	40	1.575	55	2.17	6.5	.256	70	2.76	83	3.27	49	1.93	10	.39	15	.59
PGFL25X4	22.8	.90	40	1.575	51	2.01	6.5	.256	66	2.60	91	3.58	53	2.09	10	.39	15	.59
PGFL25X5	22.2	.87	40	1.575	51	2.01	6.5	.256	66	2.60	88	3.46	51	2.01	10	.39	14	.55
PGFL25X6	21.6	.85	40	1.575	51	2.01	6.5	.256	66	2.60	97	3.82	56	2.20	10	.39	15	.59
PGFL25X10	21.6	.85	40	1.575	51	2.01	6.5	.256	66	2.60	123	4.84	69	2.72	10	.39	15	.59
PGFL32X4	29.8	1.17	50	1.969	63	2.48	6.5	.256	78	3.07	91	3.58	53	2.09	10	.39	15	.59
PGFL32X5	29.2	1.15	50	1.969	63	2.48	6.5	.256	78	3.07	89	3.50	52	2.05	10	.39	15	.59
PGFL32X5	29.2	1.15	50	1.969	63	2.48	6.5	.256	78	3.07	99	3.90	57	2.24	10	.39	15	.59
PGFL32X6	28.6	1.13	54	2.126	65	2.56	6.5	.256	80	3.15	97	3.82	56	2.20	10	.39	15	.59
PGFL32X8	27.9	1.10	53	2.087	66	2.60	6.5	.256	83	3.27	122	4.80	70	2.76	10	.39	18	.71
PGFL32X10	26.7	1.05	54	2.126	70	2.76	8.5	.335	88	3.46	146	5.75	82	3.23	16	.63	18	.71
PGFL32X20	25	.98	55	2.165	70	2.76	8.5	.335	88	3.46	176	6.93	86	3.39	25	.98	18	.71
PGFL32X25	25	.98	55	2.165	70	2.76	8.5	.335	88	3.46	206	8.11	77	3.03	25	.98	18	.71
PGFL32X32	25	.98	55	2.165	70	2.76	8.5	.335	88	3.46	196	7.72	91	3.58	25	.98	22	.87
PGFL40X5	37.2	1.46	63	2.480	75	2.95	6.5	.256	90	3.54	100	3.94	58	2.28	10	.39	16	.63
PGFL40X6	36.6	1.44	63	2.480	75	2.95	6.5	.256	90	3.54	98	3.86	57	2.24	10	.39	16	.63
PGFL40X6	36.6	1.44	63	2.480	75	2.95	6.5	.256	90	3.54	110	4.33	63	2.48	10	.39	16	.63
PGFL40X8	35.9	1.41	63	2.480	79	3.11	8.5	.335	96	3.78	122	4.80	70	2.76	10	.39	18	.71
PGFL40X10	34.7	1.37	63	2.480	79	3.11	8.5	.335	96	3.78	146	5.75	82	3.23	16	.63	18	.71
PGFL40X10	34.7	1.37	63	2.480	79	3.11	8.5	.335	96	3.78	166	6.54	92	3.62	16	.63	18	.71
PGFL40X12	34.1	1.34	63	2.480	80	3.15	10.5	.413	100	3.94	174	6.85	99	3.90	16	.63	24	.94
PGFL40X20	34.7	1.37	63	2.480	80	3.15	10.5	.413	100	3.94	224	8.82	124	4.88	25	.98	26	1.02
PGFL40X40	32	1.26	84	3.307	104	4.09	10.5	.413	126	4.96	210	8.26	110	4.33	25	.98	24	.94
PGFL50X5	47.2	1.86	72	2.835	88	3.46	8.5	.335	106	4.17	100	3.94	58	2.28	10	.39	16	.63
PGFL50X6	46.6	1.83	72	2.835	90	3.54	10.5	.413	112	4.41	114	4.49	67	2.64	10	.39	20	.79
PGFL50X10	44.7	1.76	72	2.835	90	3.54	10.5	.413	112	4.41	148	5.83	84	3.31	16	.63	20	.79
PGFL50X10	44.7	1.76	72	2.835	90	3.54	10.5	.413	112	4.41	168	6.61	94	3.70	16	.63	20	.79
PGFL50X12	44.1	1.74	75	2.953	93	3.66	10.5	.413	115	4.53	174	6.85	99	3.90	16	.63	24	.94

²⁾ Inch Dimension Tolerance - .008, -.012.

PGFL Double Preloaded Flanged Nut

MRC Machine Tools

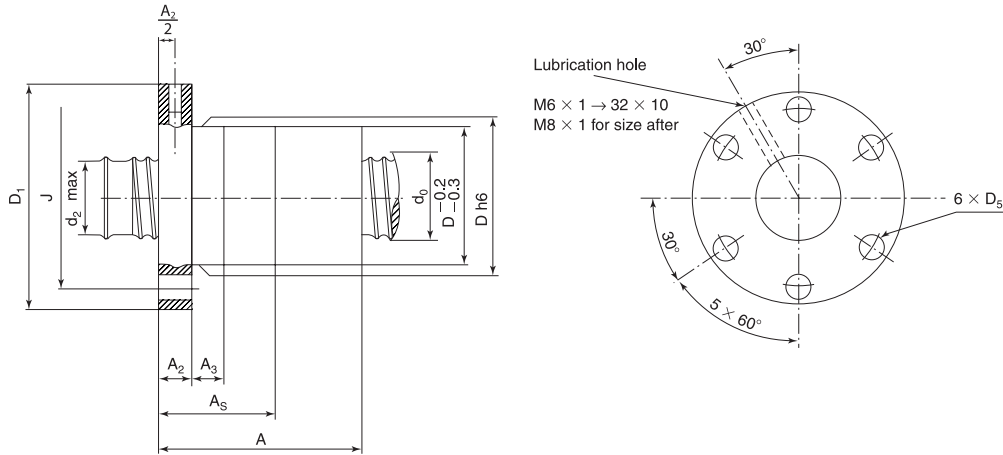

Designation	Screw Diameter d_0		Lead P_h		Number of Circuits of Balls	Basic Load Ratings				Preload Torque T_{pe}		Nut Stiffness R_n	
						Dynamic C_a		Static C_{oa}					
	mm	in	mm	in		kN	lbf	kN	lbf	Nm	lbf-ft	daN/ μm	lbf/ μm^1
PGFL50X20	50	1.9685	20	.79	3	62.5	14100	147	33000	.99	.73	177	398
PGFL50X50	50	1.9685	50	1.97	1.8	36.5	8210	72.8	16400	.30	.22	122	274
PGFL63X5	63	2.4803	5	.20	4	30	6740	120	27000	.58	.43	280	629
PGFL63X5	63	2.4803	5	.20	6	42	9440	180	40500	.81	.60	400	899
PGFL63X10	63	2.4803	10	.39	4	77.5	17400	227	51000	1.51	1.11	292	656
PGFL63X10	63	2.4803	10	.39	6	110	24700	345	77600	2.15	1.59	408	917
PGFL63X12	63	2.4803	12	.47	4	89	20000	248	55800	1.75	1.29	291	654
PGFL63X20	63	2.4803	20	.79	3	99	22300	234	52600	1.98	1.46	220	495
PGFL63X30	63	2.4803	30	1.18	3	99	22300	234	52600	1.98	1.46	220	495
PGFL63X50	63	2.4803	50	1.97	1.8	40	8990	114	25600	.40	.30	150	337
PGFL80X10	80	3.1496	10	.39	4	86	19300	293	65900	2.12	1.56	369	830
PGFL80X10	80	3.1496	10	.39	6	121	27200	439	98700	2.98	2.20	520	1170
PGFL80X12	80	3.1496	12	.47	4	101	22700	330	74200	2.50	1.84	360	809
PGFL80X16	80	3.1496	16	.63	4	147	33000	420	94400	3.67	2.71	360	809
PGFL80X20	80	3.1496	20	.79	3	162	36400	393	88300	4.12	3.04	305	686
PGFL80X20	80	3.1496	20	.79	4	207	46500	524	118000	5.26	3.88	420	944
PGFL100X10	100	3.9370	10	.39	4	100	22500	372	83600	3.06	2.26	409	919
PGFL100X10	100	3.9370	10	.39	6	142	31900	558	125000	4.35	3.21	620	1390
PGFL100X12	100	3.9370	12	.47	4	112	25200	425	95500	3.40	2.51	430	967
PGFL100X12	100	3.9370	12	.47	6	158	35500	633	142000	4.80	3.54	600	1350
PGFL100X16	100	3.9370	16	.63	4	162	36400	532	120000	5.02	3.70	440	989
PGFL100X20	100	3.9370	20	.79	3	184	41400	514	116000	5.78	4.26	365	821
PGFL100X20	100	3.9370	20	.79	4	235	52800	685	154000	7.38	5.44	490	1100
PGFL125X12	125	4.9213	12	.47	3	96	21600	402	90400	3.67	2.71	386	868
PGFL125X12	125	4.9213	12	.47	6	174	39100	803	181000	6.65	4.90	700	1570
PGFL125X16	125	4.9213	16	.63	4	182	40900	696	156000	7.00	5.16	430	967
PGFL125X20	125	4.9213	20	.79	3	210	47200	684	154000	8.16	6.02	483	1090
PGFL125X20	125	4.9213	20	.79	4	269	60500	910	205000	10.45	7.71	610	1370

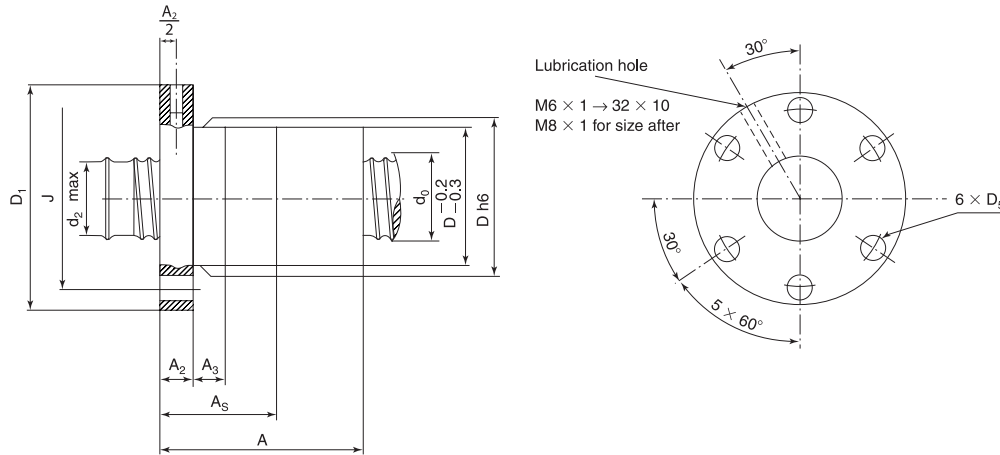

Designation	d ₂		D		J		D ₅		D ₁		A Dbl Nut		A _S Sgle Nut		A ₃		A ₂	
	mm	in	mm	in ²	mm	in	mm	in	mm	in	mm	in	mm	in	mm	in	mm	in
PGFL50X20	44.1	1.73	75	2.953	93	3.66	10.5	.413	115	4.53	234	9.21	132	5.20	25	.98	30	1.18
PGFL50X50	42	1.65	90	3.543	114	4.49	10.5	.413	135	5.31	280	11.02	130	5.12	25	.98	24	.94
PGFL63X5	60.2	2.37	90	3.543	105	4.13	8.5	.335	123	4.84	102	4.02	60	2.36	10	.39	18	.71
PGFL63X5	60.2	2.37	90	3.543	105	4.13	8.5	.335	123	4.84	122	4.80	70	2.76	10	.39	18	.71
PGFL63X10	57.7	2.27	90	3.543	110	4.33	13	.512	135	5.31	170	6.69	96	3.78	16	.63	22	.87
PGFL63X10	57.7	2.27	90	3.543	110	4.33	13	.512	135	5.31	210	8.27	116	4.57	16	.63	22	.87
PGFL63X12	57.1	2.25	95	3.740	115	4.53	13	.512	140	5.51	198	7.80	111	4.37	16	.63	24	.94
PGFL63X20	55	2.17	95	3.740	115	4.53	13	.512	140	5.51	256	10.08	143	5.63	25	.98	32	1.26
PGFL63X30	55	2.17	95	3.740	115	4.53	13	.512	140	5.51	308	12.13	168	6.61	25	.98	28	1.10
PGFL63X50	55	2.17	100	3.937	124	4.88	13	.512	147	5.79	284	11.18	154	6.06	25	.98	24	.94
PGFL80X10	74.7	2.94	105	4.134	125	4.92	13	.512	150	5.91	172	6.77	98	3.86	16	.63	24	.94
PGFL80X10	74.7	2.94	105	4.134	125	4.92	13	.512	150	5.91	212	8.35	118	4.65	16	.63	24	.94
PGFL80X12	74.1	2.92	110	4.331	130	5.12	13	.512	156	6.14	200	7.87	113	4.45	16	.63	26	1.02
PGFL80X16	72	2.83	115	4.528	141	5.55	17	.669	173	6.81	260	10.24	144	5.67	16	.63	28	1.10
PGFL80X20	69.7	2.74	125	4.921	151	5.94	17	.669	183	7.20	282	11.10	157	6.18	25	.98	32	1.26
PGFL80X20	69.7	2.74	125	4.921	151	5.94	17	.669	183	7.20	322	12.68	177	6.97	25	.98	32	1.26
PGFL100X10	94.7	3.73	125	4.921	151	5.94	17	.669	183	7.20	176	6.93	102	4.02	16	.63	28	1.10
PGFL100X10	94.7	3.73	125	4.921	151	5.94	17	.669	183	7.20	216	8.50	122	4.80	16	.63	28	1.10
PGFL100X12	94.1	3.70	135	5.315	161	6.34	17	.669	193	7.60	202	7.95	115	4.53	16	.63	28	1.10
PGFL100X12	94.1	3.70	135	5.315	161	6.34	17	.669	193	7.60	250	9.84	139	5.47	16	.63	28	1.10
PGFL100X16	92	3.62	135	5.315	161	6.34	17	.669	193	7.60	260	10.24	144	5.67	16	.63	28	1.10
PGFL100X20	89.7	3.53	150	5.906	184	7.24	21	.827	224	8.82	288	11.34	163	6.42	25	.98	38	1.50
PGFL100X20	89.7	3.53	150	5.906	184	7.24	21	.827	224	8.82	328	12.91	183	7.20	25	.98	38	1.50
PGFL125X12	119.1	4.69	165	6.496	191	7.52	17	.669	223	8.78	182	7.17	107	4.21	16	.63	32	1.26
PGFL125X12	119.1	4.69	165	6.496	191	7.52	17	.669	223	8.78	254	10.00	143	5.63	16	.63	32	1.26
PGFL125X16	117	4.61	165	6.496	191	7.52	17	.669	223	8.78	264	10.39	148	5.83	16	.63	32	1.26
PGFL125X20	114.7	4.52	170	6.693	205	8.07	21	.827	244	9.61	288	11.34	163	6.42	25	.98	38	1.50
PGFL125X20	114.7	4.52	170	6.693	205	8.07	21	.827	244	9.61	328	12.91	183	7.20	25	.98	38	1.50

¹⁾ One micron (µm) equals .0000394 inches.

²⁾ Inch Dimension Tolerance -008, -012.

PGFE Double Preloaded Flanged Nut, DIN Standard

MRC Machine Tools

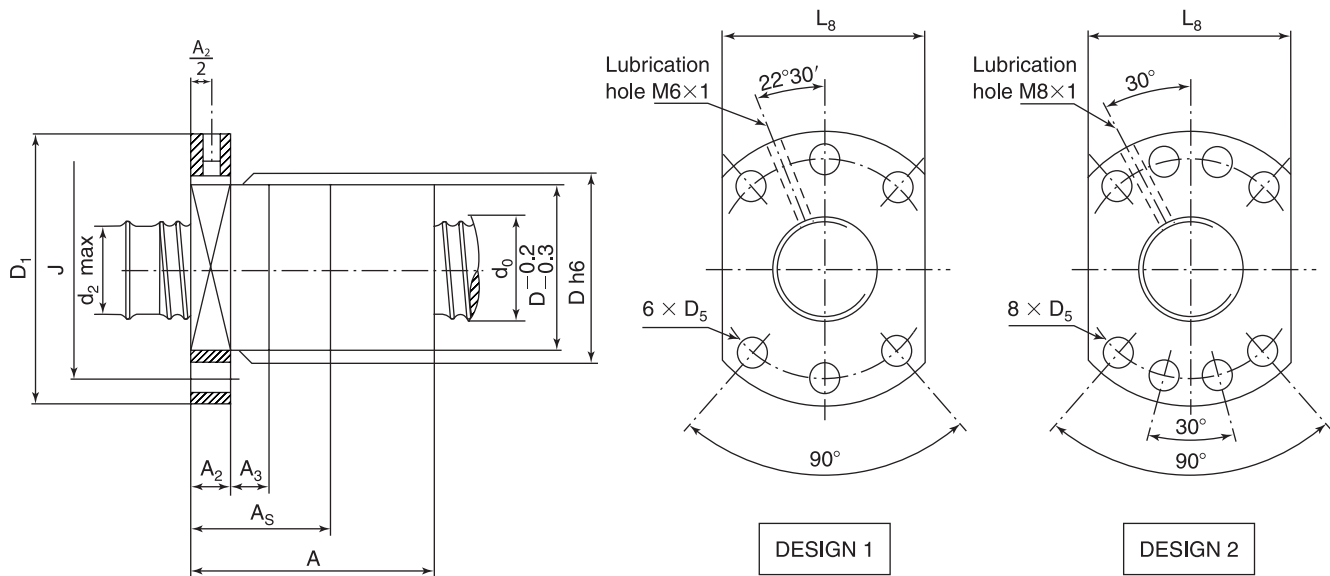

Designation	Screw Diameter		Lead	Number of Circuits of Balls	Basic Load Ratings				Preload Torque		Nut Stiffness		d ₂		D		
	d ₀				P _h	Dynamic C _a		Static C _{0a}		T _{pe}		R _n		D			
	mm	in	mm	in	kN	lbf	kN	lbf	Nm	lbf-ft	daN/μm	lbf/μm ¹	mm	n	mm	in ²	
PGFE16X5	16	.6299	5	.20	3	9.7	2180	14.2	3190	.05	.037	49	110	13.2	.52	28	1.102
PGFE20X5	20	.7874	5	.20	3	13.4	3010	24.5	5510	.08	.059	78	175	17.2	.68	36	1.417
PGFE25X5	25	.9843	5	.20	3	15.6	3510	33.6	7550	.12	.089	102	229	22.2	.87	40	1.575
PGFE25X10	25	.9843	10	.39	3	20.2	4540	39.5	8880	.16	.12	98	220	21.6	.85	40	1.575
PGFE32X5	32	1.2598	5	.20	3	17.3	3890	42.8	9620	.17	.13	120	270	29.2	1.15	50	1.969
PGFE32X5	32	1.2598	5	.20	4	22.1	4880	57	12800	.22	.16	153	344	29.2	1.15	50	1.969
PGFE32X10	32	1.2598	10	.39	3	42.2	9490	80	18000	.43	.32	130	292	26.7	1.05	50	1.969
PGFE 40X5	40	1.5748	5	.20	4	24.6	5530	73	16400	.30	.22	192	432	37.2	1.46	63	2.480
PGFE 40X10	40	1.5748	10	.39	3	46.5	10500	98	22000	.59	.44	148	333	34.7	1.37	63	2.480
PGFE 40X10	40	1.5748	10	.39	4	59.6	13400	130	29200	.75	.55	186	418	34.7	1.37	63	2.480
PGFE 50X5	50	1.9685	5	.20	4	27.2	6110	93	20900	.41	.30	244	549	47.2	1.86	75	2.952
PGFE 50X10	50	1.9685	10	.39	4	68	15300	170	38200	1.06	.78	242	544	44.7	1.76	75	2.952
PGFE 63X5	63	2.4803	5	.20	4	30	6740	120	27000	.58	.43	280	629	60.2	2.37	90	3.543
PGFE 63X5	63	2.4803	5	.20	6	42	9440	180	40500	.81	.60	400	899	60.2	2.37	90	3.543
PGFE 63X10	63	2.4803	10	.39	4	77.5	17400	227	51000	1.51	1.11	292	656	57.7	2.27	90	3.543
PGFE 63X10	63	2.4803	10	.39	6	110	24700	345	77600	2.15	1.59	408	917	57.7	2.27	90	3.543
PGFE 63X20	63	2.4803	20	.79	3	99	22300	234	52600	1.98	1.46	220	495	55	2.17	95	3.740
PGFE 80X10	80	3.1496	10	.39	4	86	19300	293	65900	2.12	1.56	369	830	74.7	2.94	105	4.134
PGFE 80X10	80	3.1496	10	.39	6	121	27200	439	98700	2.98	2.20	520	1170	74.7	2.94	105	4.134
PGFE 80X20	80	3.1496	20	.79	3	162	36400	393	88300	4.12	3.04	305	686	69.7	2.74	125	4.922
PGFE 80X20	80	3.1496	20	.79	4	207	46500	524	118000	5.26	3.88	420	944	69.7	2.74	125	4.922
PGFE 100X10	100	3.9370	10	.39	4	100	22500	372	83600	3.06	2.26	409	919	94.7	3.73	125	4.922
PGFE 100X10	100	3.9370	10	.39	6	142	31900	558	125000	4.35	3.21	620	1390	94.7	3.73	125	4.922
PGFE 100X20	100	3.9370	20	.79	3	184	41400	514	116000	5.78	4.26	365	821	89.7	3.53	150	5.906
PGFE 100X20	100	3.9370	20	.79	4	235	52800	685	154000	7.38	5.44	490	1100	89.7	3.53	150	5.906
PGFE 125X20	125	4.9213	20	.79	3	210	47200	684	154000	8.16	6.02	483	1090	114.7	4.52	170	6.693
PGFE 125X20	125	4.9213	20	.79	4	269	60500	910	205000	10.45	7.71	610	1370	114.7	4.52	170	6.693

¹) One micron (μm) equals .0000394 inches.

²) Inch dimension tolerance -.008, -.012.

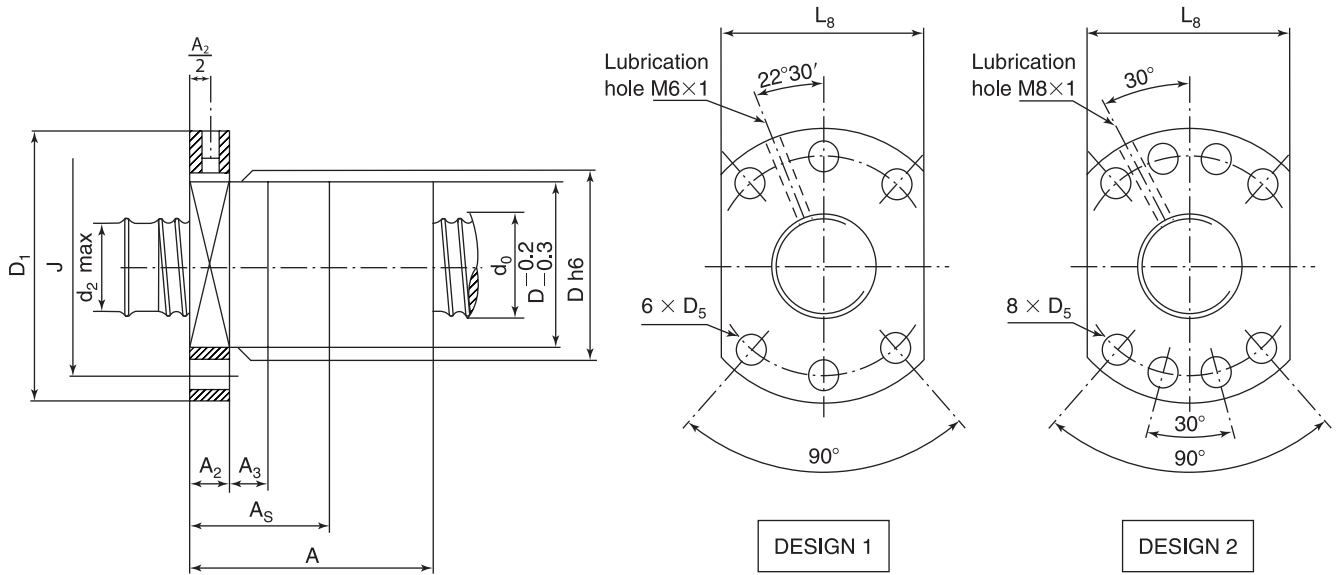

Designation	J		Design	D ₅		D ₁		A Dbl Nut		A _s Sgle Nut		A ₃		A ₂		L ₈	
	mm	in		mm	in	mm	in	mm	in	mm	in	mm	in	mm	in	mm	in
PGFE16X5	38	1.50	1	5.5	.217	48	1.89	79	3.11	45.5	1.79	10	.39	12	.47	40	1.57
PGFE20X5	47	1.85	1	6.6	.260	58	2.28	79	3.11	45.5	1.79	10	.39	12	.47	44	1.73
PGFE25X5	51	2.01	1	6.6	.260	62	2.44	88	3.46	51	2.01	10	.39	14	.55	48	1.89
PGFE25X10	51	2.01	1	6.6	.260	62	2.44	123	4.84	69	2.72	10	.39	15	.59	48	1.89
PGFE32X5	65	2.56	1	9	.354	80	3.15	89	3.50	52	2.05	10	.39	15	.59	62	2.44
PGFE32X5	65	2.56	1	9	.354	80	3.15	99	3.90	57	2.24	10	.39	15	.59	62	2.44
PGFE32X10	65	2.56	1	9	.354	80	3.15	146	5.75	82	3.23	16	.63	18	.71	62	2.44
PGFE40X5	78	3.07	2	9	.354	93	3.66	100	3.94	58	2.28	10	.39	16	.63	70	2.76
PGFE40X10	78	3.07	2	9	.354	93	3.66	146	5.75	82	3.23	16	.63	18	.71	70	2.76
PGFE40X10	78	3.07	2	9	.354	93	3.66	166	6.54	92	3.62	16	.63	18	.71	70	2.76
PGFE50X5	93	3.66	2	11	.433	110	4.33	100	3.94	58	2.28	10	.39	16	.63	85	3.35
PGFE50X10	93	3.66	2	11	.433	110	4.33	168	6.61	94	3.70	16	.63	20	.79	85	3.35
PGFE63X5	108	4.25	2	11	.433	125	4.92	102	4.02	60	2.36	10	.39	18	.71	95	3.74
PGFE63X5	108	4.25	2	11	.433	125	4.92	122	4.80	70	2.76	10	.39	18	.71	95	3.74
PGFE63X10	108	4.25	2	11	.433	125	4.92	170	6.69	96	3.78	16	.63	22	.87	95	3.74
PGFE63X10	108	4.25	2	11	.433	125	4.92	210	8.27	116	4.57	16	.63	22	.87	95	3.74
PGFE63X20	115	4.53	2	13.5	.531	135	5.31	256	10.08	143	5.63	25	.98	32	1.26	100	3.94
PGFE80X10	125	4.92	2	13.5	.531	145	5.71	172	6.77	98	3.86	16	.63	24	.94	110	4.33
PGFE80X10	125	4.92	2	13.5	.531	145	5.71	212	8.35	118	4.65	16	.63	24	.94	110	4.33
PGFE80X20	145	5.71	2	13.5	.531	165	6.50	282	11.10	157	6.18	25	.98	32	1.26	130	5.12
PGFE80X20	145	5.71	2	13.5	.531	165	6.50	322	12.68	177	6.97	25	.98	32	1.26	130	5.12
PGFE100X10	145	5.71	2	13.5	.531	165	6.50	176	6.93	102	4.02	16	.63	28	1.10	130	5.12
PGFE100X10	145	5.71	2	13.5	.531	165	6.50	216	8.50	122	4.80	16	.63	28	1.10	130	5.12
PGFE100X20	176	6.93	2	17.5	.689	202	7.95	288	11.34	163	6.42	25	.98	38	1.50	155	6.10
PGFE100X20	176	6.93	2	17.5	.689	202	7.95	328	12.91	183	7.20	25	.98	38	1.50	155	6.10
PGFE125X20	196	7.72	2	17.5	.689	222	8.74	288	11.34	163	6.42	25	.98	38	1.50	175	6.89
PGFE125X20	196	7.72	2	17.5	.689	222	8.74	328	12.91	183	7.20	25	.98	38	1.50	175	6.89

¹⁾ One micron (µm) equals .0000394 inches.
²⁾ Inch dimension tolerance -.008, -.012.

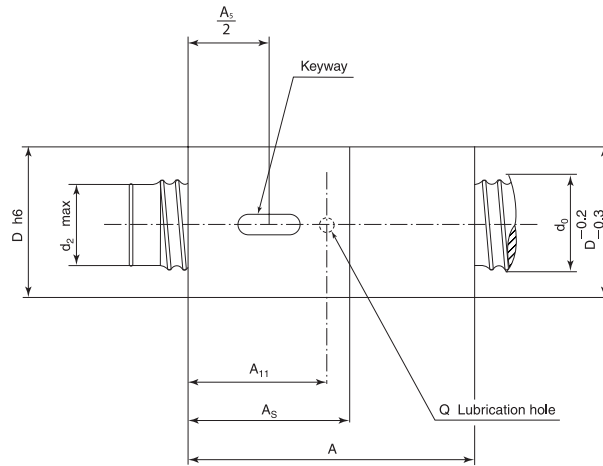

Designation	Screw Diameter d_0		Lead P_h		Number of Circuits of Balls	Basic Load Ratings				Preload Torque T_{pe}		Nut Stiffness R_n	
	mm	in	mm	in		Dynamic C_a		Static C_{oa}		Nm	lbf-ft	daN/ μm	lbf/ μm^1
						kN	lbf	kN	lbf				
PGCL16X5	16	.6299	5	.20	3	9.7	2180	14.2	3190	.05	.037	49	110
PGCL20X5	20	.7874	5	.20	3	13.4	3010	24.5	5510	.08	.059	78	175
PGCL25X2	25	.9843	2	.08	4	7.8	1750	23	5170	.06	.044	60	135
PGCL25X4	25	.9843	4	.16	4	14.4	3240	35	7870	.11	.081	120	270
PGCL25X5	25	.9843	5	.20	3	15.6	3510	33.6	7550	.12	.089	102	229
PGCL25X6	25	.9843	6	.24	3	20.7	4650	40.5	9100	.16	.12	100	225
PGCL25X10	25	.9843	10	.39	3	20.2	4540	39.5	8880	.16	.12	98	220
PGCL32X4	32	1.2598	4	.16	4	16.5	3710	48	10800	.16	.12	140	315
PGCL32X5	32	1.2598	5	.20	3	17.3	3890	42.8	9620	.17	.13	120	270
PGCL32X5	32	1.2598	5	.20	4	22.1	9670	57	12800	.22	.16	153	344
PGCL32X6	32	1.2598	6	.24	3	23.3	5240	52.5	11800	.23	.17	124	279
PGCL32X8	32	1.2598	8	.31	3	29.5	6630	62	13900	.30	.22	128	288
PGCL32X10	32	1.2598	10	.39	3	42.2	9490	80	18000	.43	.32	130	292
PGCL40X5	40	1.5748	5	.20	4	24.6	5530	73	16400	.30	.22	192	432
PGCL40X6	40	1.5748	6	.24	3	25.8	5800	66.9	15000	.32	.24	113	254
PGCL40X6	40	1.5748	6	.24	4	33.1	7440	89	20000	.41	.30	145	326
PGCL40X8	40	1.5748	8	.31	3	33	7420	79	17800	.41	.30	145	326
PGCL40X10	40	1.5748	10	.39	3	46.5	10500	98	22000	.59	.44	148	333
PGCL40X10	40	1.5748	10	.39	4	59.6	13400	130	29200	.75	.55	186	418
PGCL40X12	40	1.5748	12	.47	3	53.9	12100	109	24500	.69	.51	150	337
PGCL40X20	40	1.5748	20	.79	3	46	10300	98	22000	.59	.44	147	330
PGCL50X5	50	1.9685	5	.20	4	27.2	6110	93	20900	.41	.30	244	549
PGCL50X6	50	1.9685	6	.24	4	37	8320	114	25600	.57	.42	254	571
PGCL50X10	50	1.9685	10	.39	3	53	11900	128	28800	.82	.60	189	425
PGCL50X10	50	1.9685	10	.39	4	68	15300	170	38200	1.06	.78	242	544
PGCL50X12	50	1.9685	12	.47	3	62.8	14100	147	33000	.99	.73	170	382
PGCL50X20	50	1.9685	20	.79	3	62.5	14100	147	33000	.99	.73	177	398
PGCL63X5	63	2.4803	5	.20	4	30	6740	120	27000	.58	.43	280	629
PGCL63X5	63	2.4803	5	.20	6	42	9440	180	40500	.81	.60	400	899
PGCL63X10	63	2.4803	10	.39	4	77.5	17400	227	51000	1.51	1.11	292	656

¹⁾ One Micron (μm) equals .0000394 Inches.

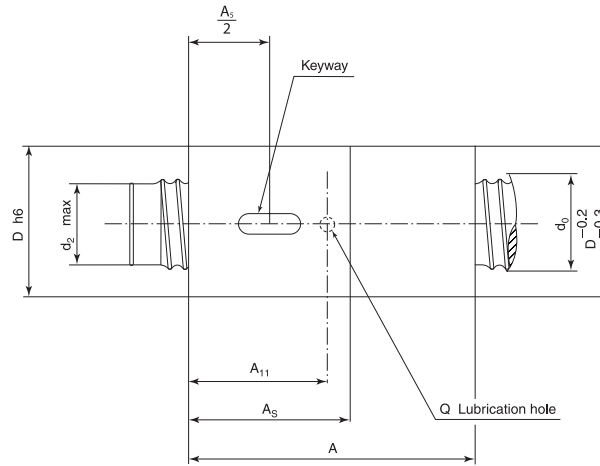

Designation	d_2		D		Keyway	A		A_s		A_{11}		Lub. Diameter Q	
	mm	in	mm	in ²⁾		mm	in	mm	in	mm	in	mm	in
PGCL16X5	13.2	.52	28	1.102	4 × 2.5 × 14	73	2.87	39.5	1.56	30.2	1.19	3	.12
PGCL20X5	17.2	.68	36	1.417	4 × 2.5 × 14	73	2.87	39.5	1.56	30.2	1.19	3	.12
PGCL25X2	23.8	.94	40	1.575	4 × 2.5 × 20	75	2.95	41	1.61	31	1.22	1.5	.06
PGCL25X4	22.8	.90	40	1.575	4 × 2.5 × 20	83	3.27	45	1.77	33	1.30	2.5	.10
PGCL25X5	22.2	.87	40	1.575	4 × 2.5 × 20	81	3.19	44	1.73	33	1.30	3	.12
PGCL25X6	21.6	.85	40	1.575	4 × 2.5 × 25	89	3.50	48	1.89	36.5	1.44	4	.16
PGCL25X10	21.6	.85	40	1.575	4 × 2.5 × 25	115	4.53	61	2.40	49.7	1.96	4	.16
PGCL32X4	29.8	1.17	50	1.969	4 × 2.5 × 20	83	3.27	45	1.77	33	1.30	2.5	.10
PGCL32X5	29.2	1.15	50	1.969	4 × 2.5 × 20	81	3.19	44	1.73	33	1.30	3	.12
PGCL32X5	29.2	1.15	50	1.969	4 × 2.5 × 25	91	3.58	49	1.93	38	1.50	3	.12
PGCL32X6	28.6	1.13	54	2.126	4 × 2.5 × 25	89	3.50	48	1.89	36.5	1.44	4	.16
PGCL32X8	27.9	1.10	53	2.087	4 × 2.5 × 25	112	4.41	60	2.36	46.5	1.83	4.5	.18
PGCL32X10	26.7	1.05	54	2.126	4 × 2.5 × 25	138	5.43	74	2.91	58	2.28	6.2	.24
PGCL40X5	37.2	1.46	63	2.480	6 × 3.5 × 25	91	3.58	49	1.93	38	1.50	3	.12
PGCL40X6	36.6	1.44	63	2.480	6 × 3.5 × 25	89	3.50	48	1.89	36.5	1.44	4	.16
PGCL40X6	36.6	1.44	63	2.480	6 × 3.5 × 25	101	3.98	54	2.13	42.5	1.67	4	.16
PGCL40X8	35.9	1.41	63	2.480	6 × 3.5 × 25	112	4.41	60	2.36	46.5	1.83	4.5	.18
PGCL40X10	34.7	1.37	63	2.480	6 × 3.5 × 32	138	5.43	74	2.91	58	2.28	6.2	.24
PGCL40X10	34.7	1.37	63	2.480	6 × 3.5 × 32	158	6.22	84	3.31	69	2.72	6.2	.24
PGCL40X12	34.1	1.34	63	2.480	6 × 3.5 × 32	162	6.38	87	3.43	68.5	2.70	7	.28
PGCL40X20	34.7	1.37	63	2.480	6 × 3.5 × 32	218	8.58	118	4.65	95.6	3.76	7	.28
PGCL50X5	47.2	1.86	72	2.835	6 × 3.5 × 25	91	3.58	49	1.93	38	1.50	3	.12
PGCL50X6	46.6	1.83	72	2.835	6 × 3.5 × 25	101	3.98	54	2.13	43	1.69	4	.16
PGCL50X10	44.7	1.76	72	2.835	6 × 3.5 × 32	138	5.43	74	2.91	69	2.72	6.2	.24
PGCL50X10	44.7	1.76	72	2.835	6 × 3.5 × 32	158	6.22	84	3.31	68.5	2.70	6.2	.24
PGCL50X12	44.1	1.74	75	2.835	6 × 3.5 × 32	162	6.38	87	3.43	58	2.28	7	.28
PGCL50X20	44.1	1.74	75	2.835	6 × 3.5 × 32	222	8.74	120	4.72	97	3.82	7	.28
PGCL63X5	60.2	2.37	90	3.543	6 × 3.5 × 25	91	3.58	49	1.93	37.5	1.48	3	.12
PGCL63X5	60.2	2.37	90	3.543	6 × 3.5 × 32	111	4.37	59	2.32	47.5	1.87	3	.12
PGCL63X10	57.7	2.27	90	3.543	8 × 4 × 32	158	6.22	84	3.31	69	2.72	6.2	.24

²⁾ Inch dimension tolerance – .008, – .012.

PGCL Cylindrical Double Preloaded Nut

MRC Machine Tools

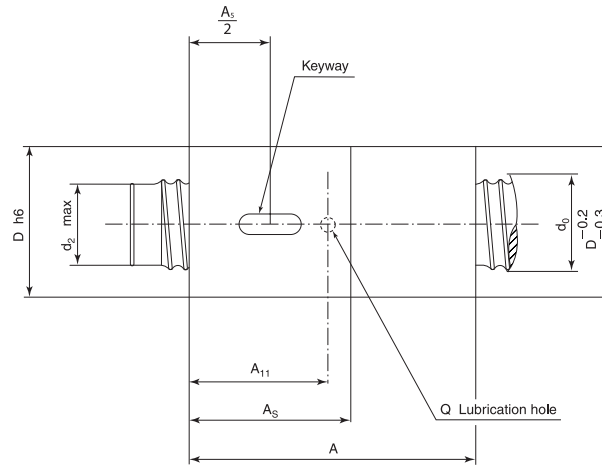

Designation	Screw Diameter d_0		Lead P_h		Number of Circuits of Balls	Basic Load Ratings				Preload Torque T_{pe}		Nut Stiffness R_n	
						Dynamic C_a		Static C_{oa}					
	mm	in	mm	in		kN	lbf	kN	lbf	Nm	lbf-ft	daN/ μm	lbf/ μm^1
PGCL63X10	63	2.4803	10	.39	6	110	24700	345	77600	2.15	1.59	408	917
PGCL63X12	63	2.4803	12	.47	4	89	20000	248	55800	1.75	1.29	291	654
PGCL63X20	63	2.4803	20	.79	3	99	22300	234	52600	1.98	1.46	220	495
PGCL63X30	63	2.4803	30	1.18	3	99	22300	234	52600	1.98	1.46	220	495
PGCL80X10	80	3.1496	10	.39	4	86	19300	293	65900	2.12	1.56	369	830
PGCL80X10	80	3.1496	10	.39	6	121	27200	439	98700	2.98	2.20	520	1170
PGCL80X12	80	3.1496	12	.47	4	101	22700	330	74200	2.50	1.84	360	809
PGCL80X16	80	3.1496	16	.63	4	147	33000	420	94400	3.67	2.71	360	809
PGCL80X20	80	3.1496	20	.79	3	162	36400	393	88300	4.12	3.04	305	686
PGCL80X20	80	3.1496	20	.79	4	207	46500	524	118000	5.26	3.88	420	944
PGCL100X10	100	3.9370	10	.39	4	100	22500	372	83600	3.06	2.26	409	919
PGCL100X10	100	3.9370	10	.39	6	142	31900	558	125000	4.35	3.21	620	1390
PGCL100X12	100	3.9370	12	.47	4	112	25200	425	95500	3.40	2.51	430	967
PGCL100X12	100	3.9370	12	.47	6	158	35500	633	142000	4.80	3.54	600	1350
PGCL100X16	100	3.9370	16	.63	4	162	36400	532	120000	5.02	3.70	440	989
PGCL100X20	100	3.9370	20	.79	3	184	41400	514	116000	5.78	4.26	365	821
PGCL100X20	100	3.9370	20	.79	4	235	52800	685	154000	7.38	5.44	490	1100
PGCL125X12	125	4.9213	12	.47	3	96	21600	402	90400	3.67	2.71	386	868
PGCL125X12	125	4.9213	12	.47	6	174	39100	803	181000	6.65	4.90	700	1570
PGCL125X16	125	4.9213	16	.63	4	182	40900	696	156000	7.00	5.16	430	967
PGCL125X20	125	4.9213	20	.79	3	210	47200	684	154000	8.16	6.02	483	1090
PGCL125X20	125	4.9213	20	.79	4	269	60500	910	205000	10.45	7.71	610	1370

¹⁾ One micron (μm) equals .0000394 inches.

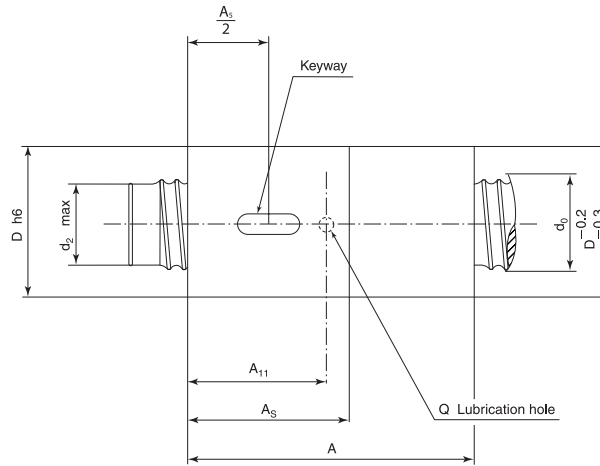

Designation	d ₂		D		Keyway mm	A Dbl Nut		A ₁₁ Sgle Nut		A ₁₁		Lub. Diameter Q	
	mm	in	mm	in ²⁾		mm	in	mm	in	mm	in	mm	in
PGCL63X10	57.7	2.27	90	3.543	8 × 4 × 40	198	7.80	104	4.09	88	3.46	6.2	.24
PGCL63X12	57.1	2.25	95	3.740	8 × 4 × 32	186	7.32	99	3.90	82	3.23	7	.28
PGCL63X20	55	2.17	95	3.740	8 × 4 × 40	248	9.76	135	5.31	108.5	4.27	9.5	.37
PGCL63X30	55	2.17	95	3.740	8 × 4 × 40	295	11.61	155	6.10	132.5	5.22	9.5	.37
PGCL80X10	74.7	2.94	105	4.134	8 × 4 × 32	158	6.22	84	3.31	69	2.72	6.2	.24
PGCL80X10	74.7	2.94	105	4.134	8 × 4 × 40	198	7.80	104	4.09	88	3.46	6.2	.24
PGCL80X12	74.1	2.92	110	4.331	8 × 4 × 32	186	7.32	99	3.90	81.5	3.21	7	.28
PGCL80X16	72	2.83	115	4.528	8 × 4 × 40	248	9.76	132	5.20	108	4.25	9.5	.37
PGCL80X20	69.7	2.74	125	4.921	8 × 4 × 40	270	10.63	145	5.71	114	4.49	12.5	.49
PGCL80X20	69.7	2.74	125	4.921	8 × 4 × 40	310	12.20	165	6.50	136.5	5.37	12.5	.49
PGCL100X10	94.7	3.73	125	4.921	10 × 5 × 32	158	6.22	84	3.31	69	2.72	6.2	.24
PGCL100X10	94.7	3.73	125	4.921	10 × 5 × 40	198	7.80	104	4.09	88	3.46	6.2	.24
PGCL100X12	94.1	3.70	135	5.315	10 × 5 × 32	186	7.32	99	3.90	81.5	3.21	7	.28
PGCL100X12	94.1	3.70	135	5.315	10 × 5 × 40	234	9.21	123	4.84	105	4.13	7	.28
PGCL100X16	92	3.62	135	5.315	10 × 5 × 40	248	9.76	132	5.20	108	4.25	9.5	.37
PGCL100X20	89.7	3.53	150	5.906	10 × 5 × 40	270	10.63	145	5.71	114	4.49	12.5	.49
PGCL100X20	89.7	3.53	150	5.906	10 × 5 × 40	310	12.20	165	6.50	136.5	5.37	12.5	.49
PGCL125X12	119.1	4.69	165	6.496	10 × 5 × 32	162	6.38	87	3.43	68.5	2.70	7	.28
PGCL125X12	119.1	4.69	165	6.496	10 × 5 × 40	234	9.21	123	4.84	105	4.13	7	.28
PGCL125X16	117	4.61	165	6.496	10 × 5 × 40	248	9.76	132	5.20	108	4.25	9.5	.37
PGCL125X20	114.7	4.52	170	6.693	10 × 5 × 40	270	10.63	145	5.71	114	4.49	12.5	.49
PGCL125X20	114.7	4.52	170	6.693	10 × 5 × 40	310	12.20	165	6.50	136.5	5.37	12.5	.49

²⁾ Inch dimension tolerance $-.008, -.012$.

Standard Machined Ends

MRC Machine Tools

Standard shaft ends for ground ball screws have been developed to suit the MRC thrust bearings units FLBU, PLBU and BUF.

If a higher load capacity is needed, please contact MRC.

Dimensions in Inches (Shaded) and Millimeters

Dimensions												
Size d ₀ mm	d ₅	d ₄	d ₁₁	d ₁₂	B ₁	B ₂	B ₃	B ₄	B ₅	B ₆	B ₇	d ₈
	h ₇ mm in	h ₆ mm in	h ₆ mm in	h ₇ mm in	js ₁₂ mm in	mm in	js ₁₂ mm in	js ₁₂ mm in	H ₁₁ mm in	js ₁₂ mm in	mm in	mm in
16	8 .3150	10 .3937	10 .3937	8 .3150	53 2.09	16 .630	13 .512	69 2.717	10 .394	29 1.142	2 .079	12.5 .492
20	10 .3937	12 .4724	10 .3937	8 .3150	58 2.28	17 .669	13 .512	75 2.953	10 .394	29 1.142	2 .079	14.5 .571
25	15 .5906	17 .6693	17 .6693	15 .5906	66 2.60	30 1.181	16 .630	96 3.780	13 .512	46 1.811	4.5 .177	20 .787
32	17 .6693	20 .7874	17 .6693	15 .5906	69 2.72	30 1.181	16 .630	99 3.898	13 .512	46 1.811	4.5 .177	21.7 .864
40	25 .9843	30 1.1811	30 1.1811	25 .9843	76 2.99	45 1.772	22 .866	121 4.764	17.5 .689	67 2.638	4.5 .177	33.5 1.319
50	30 1.1811	35 1.3780	30 1.1811	25 .9843	84 3.31	55 2.165	22 .866	139 5.472	17.5 .689	67 2.638	4.5 .177	35.2 1.388
63	40 1.5748	50 1.9685	45 1.7717	40 1.5748	114 4.49	65 2.559	28 1.102	179 7.047	20.75 .817	93 3.661	3 .118	54 2.126
80	50 1.9685	55 2.1654	45 1.7717	40 1.5748	119 4.69	75 2.953	28 1.102	194 7.638	20.75 .817	93 3.661	3 .118	54 2.126

Dimensions (cont.)											
Size d ₀ mm	G	G ₁	m	d ₆	c	c ₁	b _a	d ₇	r _a	Keyway to DIN 6885 a ^{N9} xl xb	
	6g		+0.14 ¹⁾	h11 ⁴⁾ +0	h12 ⁵⁾			h11		fixed end (type 2A)	free end (type 5A)
	mm	mm in	mm in	mm in	mm in	mm in	mm in	mm in	mm in		
16	M10 × 0.75	17 .669	1.1 .043	9.6 .378	0.5 .020	0.5 .020	1.2 .047	8.8 .346	0.4 .016	A2 × 2 × 12	A2 × 2 × 12
20	M12 × 1	18 .709	1.1 .043	9.6 .378	0.5 .020	0.5 .020	1.5 .059	10.5 .413	0.8 ²⁾ .032	A3 × 3 × 12	A2 × 2 × 12
25	M17 × 1	22 .866	1.1 .043	16.2 .638	0.5 .020	0.5 .020	1.5 .059	15.5 .610	0.8 ²⁾ .032	A5 × 5 × 25	A5 × 5 × 25
32	M20 × 1	22 .866	1.1 .043	16.2 .638	0.5 .020	0.5 .020	1.5 .059	18.5 .728	1.2 ³⁾ .047	A5 × 5 × 25	A5 × 5 × 25
40	M30 × 1.5	25 .984	1.6 .063	28.6 1.126	1 .039	0.5 .020	2.3 .091	27.8 1.094	0.8 ²⁾ .032	A8 × 7 × 40	A8 × 7 × 40
50	M35 × 1.5	27 1.063	1.6 .063	28.6 1.126	1 .039	0.5 .020	2.3 .091	32.8 1.291	1.2 ³⁾ .047	A8 × 7 × 45	A8 × 7 × 40
63	M50 × 1.5	32 1.260	1.85 .073	42.5 1.673	1.5 .059	1 .039	2.3 .091	47.8 1.882	1.2 ³⁾ .047	A12 × 8 × 50	A12 × 8 × 50
80	M55 × 2	32 1.260	1.85 .073	42.5 1.673	1.5 .059	1 .039	3 .118	52.1 2.051	1.6 ³⁾ .063	A14 × 9 × 63	A12 × 8 × 50

¹⁾ Inch dimension tolerance +.0055 + 0.

²⁾ 0.4/.0157 for shaft end 4A or 5A.

³⁾ 0.8/.0315 for shaft ends 4A or 5A.

⁴⁾ For screw do 16 to do 32.

⁵⁾ For screw do 40 to do 80.

Shaft End Combinations

Order code	Two machined ends
AA (without length indication)	cut only
AA (+ length)	cut + annealed
BA	1A + 2A
FA*	2A + 2A
GA*	2A + 3A
HA	2A + 4A
JA	2A + 5A
MA	3A + 5A
SA (+ length)	Ends to root diameter, any possible lengths
TA	Faced ends with center holes
K	Keyway
Z	To customer's drawing

*Please contact MRC for assistance.

Threaded Length = Total Length — End Length

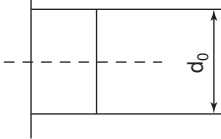
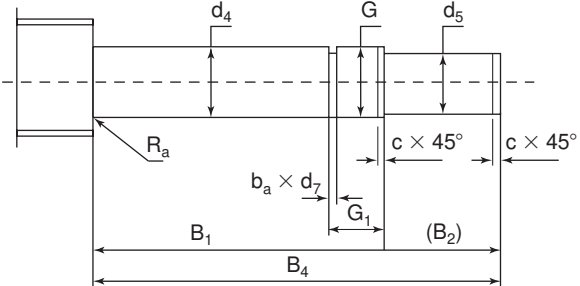
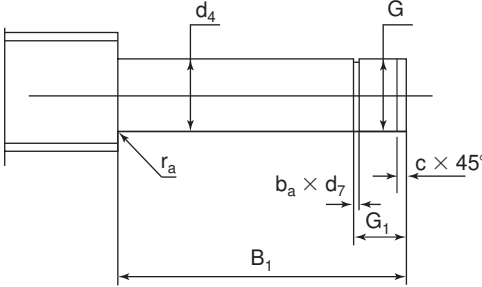
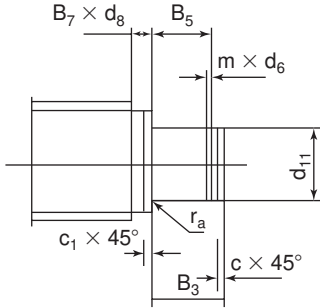
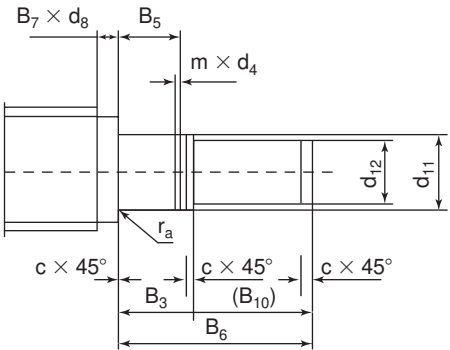
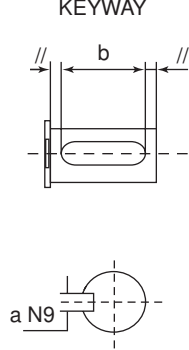
<p>1A</p> 	<p>2A</p> 
<p>3A</p> 	<p>4A</p> 
<p>5A</p> 	<p>KEYWAY</p> 

Axially Locating Flanged Housing with MRC Angular Contact Ball Bearings (Back to Back Arrangement).

During your selection, compare your application with our bearing load rating. If the capacity is not sufficient, please contact MRC.

The FLBU flanged bearing unit consists of:

- precision housing made of burnished steel \pm
- two MRC preloaded angular contact ball bearings, 72 or 73 series $\dot{\iota}$
- two garter seals \neg
- locknut, self-locking Nylstop type \surd or, on demand, high precision KMT

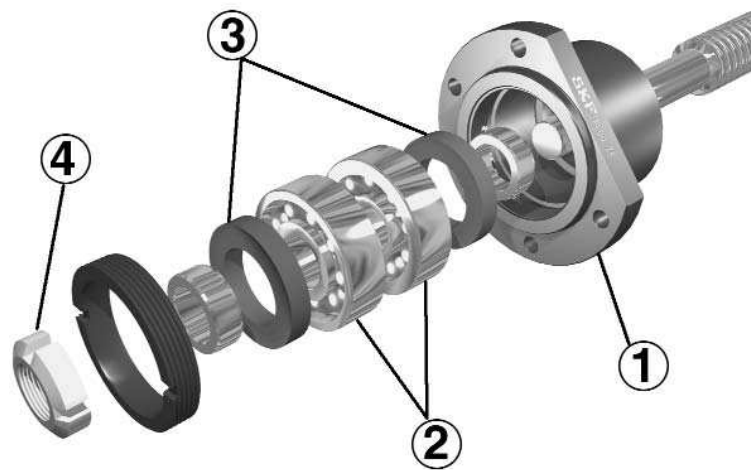

Size d _o mm	Flanged bearing unit designation	Angular contact ball bearing (40°)					Lock nut								
		Basic load rating (axial)					Self locking nut			High precision nut ³⁾					
		Dynamic C _a		Static C _{oa}		MRC bearing designation	Designation	Hook spanner	Designation	Hook spanner	Tightening torque		Grub screws		
		kN	lbf	kN	lbf						Nm	lbf-ft	Size	Nm	lbf-ft
16	FLBU16	12.2	2740	12.8	2880	7200PJDE ¹⁾	CN70-10	HN1	KMT0	HN2/3	4	3.0	M5	4.5	3.3
20	FLBU20	13.3	2990	14.7	3300	7201PJDU ²⁾	CN70-12	HN1	KMT1	HN3	8	5.9	M5	4.5	3.3
25	FLBU25	27.9	6270	31.9	7170	7303PJDU ²⁾	CN70-17	HN3	KMT3	HN4	15	11.1	M6	4.5	3.3
32	FLBU32	24.6	5530	31.9	7170	7204PJDU ²⁾	CN70-20	HN4	KMT4	HN5	18	13.3	M6	8	5.9
40	FLBU40	41.9	3350	59.6	13400	7206PJDU ²⁾	CN70-30	HN6	KMT6	HN6	32	23.6	M6	8	5.9
50	FLBU50	54.5	12300	79.8	17900	7207PJDU ²⁾	CN70-35	HN7	KMT7	HN7	40	29.5	M6	8	5.9
63	FLBU63	128	28800	196.1	44100	7310PJDU ²⁾	CN70-50	HN10	KMT10	HN10/11	60	44.3	M6	8	5.9
80	FLBU80	148	33300	230.7	51900	7311PJDU ²⁾	CN70-55	HN11	KMT11	HN12/13	70	51.6	M8	18	13.3

¹⁾ No backlash elimination.

²⁾ Light preload.

³⁾ Optional.

The “FLBU” flanged thrust bearing unit provides the following benefits:

- lubrication for life
- very easy mounting (matched bearings, hand mounting on the shaft end) as well as easy disassembly with the optional high precision KMT nut

In standard version, the FLBU thrust bearing unit is assembled according to drawing below. If you require a different assembly, please indicate it when ordering.

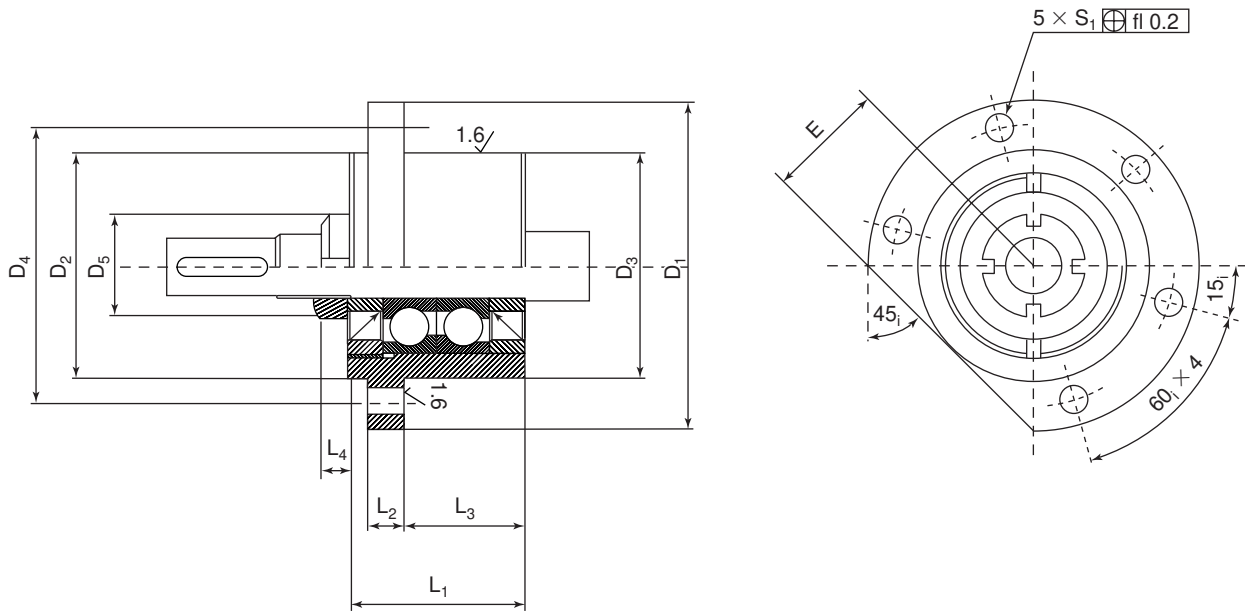

Dimensions														
Size d ₀ mm	L ₁		L ₂		L ₃		L ₄				D1		D2	
							Self locking nut		High precision nut ¹⁾					
	mm	in	mm	in	mm	in	mm	in	mm	in ³⁾	mm	in	mm	in
16	37	1.46	10	.39	22	.87	7	.28	14	.55	76	2.99	50	1.97
20	42	1.65	10	.39	25	.98	7.5	.30	14	.55	76	2.99	50	1.97
25	46	1.81	10	.39	32	1.26	8.3	.33	18	.71	90	3.54	62	2.44
32	49	1.93	13	.51	32	1.26	8.3	.33	18	.71	90	3.54	59	2.32
40	53	2.09	16	.63	32	1.26	11	.43	20	.79	120	4.72	80	3.15
50	50	2.32	20	.79	32	1.26	11	.43	22	.87	130	5.12	89	3.50
63	85	3.35	25	.98	43.5	1.71	11.7	.46	25	.98	165	6.50	124	4.88
80	90	3.54	20	.79	60	2.36	13.8	.54	25	.98	190	7.48	140	5.51

Dimensions													
Size d ₀ mm	D3		D ₄		D ₅				S1		Fixing screws	E	
	h ₇				Self locking nut		High precision nut ¹⁾		H13				
	mm	in	mm	in	mm	in	mm	in	mm	in		mm	in
16	47	1.85	63	2.48	18	.71	28	1.10	6.6	.26	M6 × 30	26	1.02
20	47	1.85	63	2.48	21	.83	30	1.18	6.6	.26	M6 × 30	27	1.06
25	60	2.36	76	2.99	28	1.10	37	1.46	6.6	.26	M6 × 30	32	1.26
32	60	2.36	74	2.91	32	1.26	40	1.57	9	.35	M8 × 40	32	1.26
40	80	3.15	100	3.94	44	1.73	49	1.93	11	.43	M10 × 45	44	1.73
50	90	3.54	110	4.33	50	1.97	54	2.13	13	.51	M12 × 60	49	1.93
63	124	4.88	146	5.75	68	2.68	75	2.95	13	.51	M12 × 60	64	2.52
80	140	5.51	166	6.54	74	2.91	85	3.35	17	.67	M16 × 65	70	2.76

¹⁾ Optional.

Fixed Plummer Housing with MRC Angular Contact Ball Bearings (Back to Back Arrangement)

During your selection, compare your application with our bearing load rating. If the capacity is not sufficient, please contact MRC.

The PLBU plummer bearing unit consists of:

- precision housing, made of burnished steel, with precision reference edges on both sides, steel \dot{z}
- two MRC preloaded angular contact ball bearings, 72 or 73 series \dot{i}

- two garter seals \dot{r}
- locknut, self-locking Nylstop type \checkmark or, on demand, high precision KMT

The PLBU plummer bearing unit provides the following benefits:

- lubrication for life
- very easy mounting (matched bearing, hand mounting on the shaft ends) as well as easy disassembly with the optional high precision KMT nut
- good rigidity guaranteed by foot mounting with dowel pins

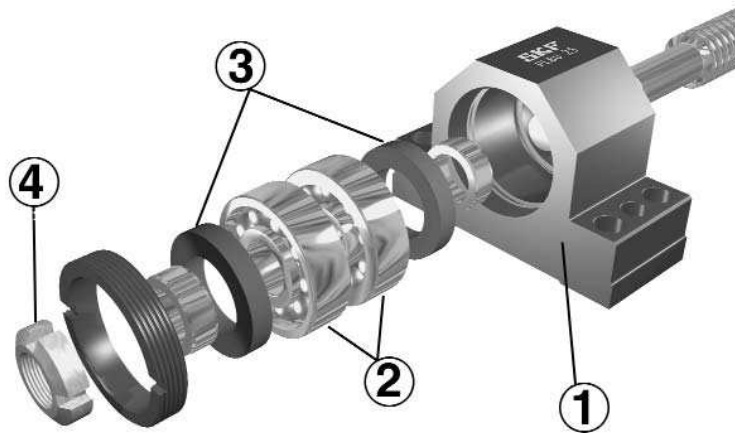

Size d_o mm	Flanged bearing unit designation	Angular contact ball bearing (40°)					Lock nut								
		Basic load rating (axial)					Self locking nut			High Precision Nut ³⁾					
		Dynamic C_a		Static C_{oa}		MRC bearing designation	Designation	Hook spanner	Designation	Hook spanner	Tightening torque		Grub screws		
		kN	lbf	kN	lbf						Nm	lbf-ft	Size	Max tightening torque	
											Nm	lbf-ft			
16	PLBU16	12.2	2740	12.8	2880	7200PJDE ¹⁾	CN70-10	HN1	KMT0	HN2/3	4	3.0	M5	4.5	3.3
20	PLBU20	13.3	2990	14.7	3300	7201PJDU ²⁾	CN70-12	HN1	KMT1	HN3	8	5.9	M5	4.5	3.3
25	PLBU25	27.9	6270	31.9	7170	7303PJDU ²⁾	CN70-17	HN3	KMT3	HN4	15	11.1	M6	4.5	3.3
32	PLBU32	24.6	5530	31.9	7170	7204PJDU ²⁾	CN70-20	HN4	KMT4	HN5	18	13.3	M6	8	5.9
40	PLBU40	41.9	9420	59.6	13400	7206PJDU ²⁾	CN70-30	HN6	KMT6	HN6	32	23.6	M6	8	5.9
50	PLBU50	54.5	12300	79.8	17900	7207PJDU ²⁾	CN70-35	HN7	KMT7	HN7	40	29.5	M6	8	5.9
63	PLBU63	128	28800	196.1	44100	7310PJDU ²⁾	CN70-50	HN10	KMT10	HN10/11	60	44.3	M6	8	5.9
80	PLBU80	148	33300	230.7	51900	7311PJDU ²⁾	CN70-55	HN11	KMT11	HN12/13	70	51.6	M8	18	13.3

¹⁾ No backlash elimination.

²⁾ Light preload.

³⁾ Optional.

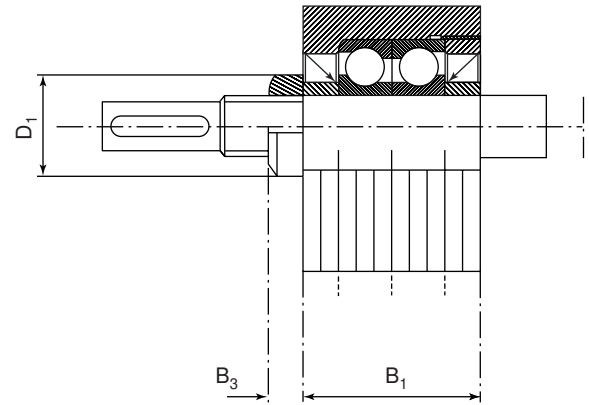
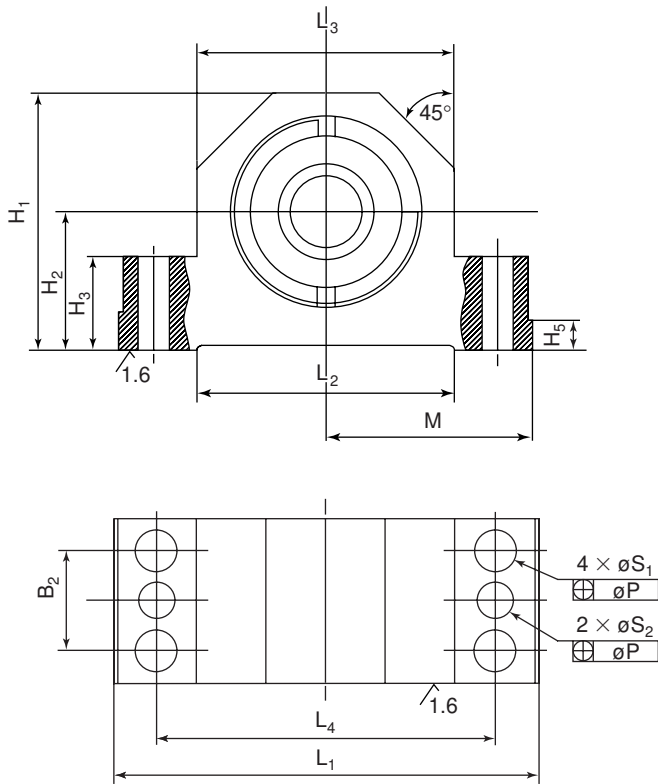

Dimensions																				
Size d ₀	B3																			
	M										Self locking nut				High precision nut ³⁾				H ₁	
	L ₁		L ₂		L ₃		L ₄		js8		B ₁		B ₂		nut		nut ³⁾		H ₁	
mm	in	mm	in	mm	in	mm	in	mm	in	mm	in	mm	in	mm	in	mm	in	mm	in	
16	86	3.39	52	2.05	52	2.05	68	2.68	43	1.69	37	1.46	23	.91	7	.28	14	.55	58	2.28
20	94	3.70	52	2.05	60	2.36	77	3.03	47	1.85	42	1.65	25	.98	7.5	.30	14	.55	64	2.52
25	108	4.25	65	2.56	66	2.60	88	3.46	54	2.13	46	1.81	29	1.14	8.3	.33	18	.71	72	2.83
32	112	4.41	65	2.56	70	2.76	92	3.62	56	2.20	49	1.93	29	1.14	8.3	.33	18	.71	77	3.03
40	126	4.96	82	3.23	80	3.15	105	4.13	63	2.48	53	2.09	32	1.26	11	.43	20	.79	98	3.86
50	144	5.67	80	3.15	92	3.62	118	4.65	72	2.83	59	2.32	35	1.38	11	.43	22	.87	112	4.41
63	190	7.48	110	4.33	130	5.12	160	6.30	95	3.74	85	3.35	40	1.57	11.7	.46	25	.98	130	5.12
80	205	8.07	120	4.72	145	5.71	175	6.89	102.5	4.04	90	3.54	60	2.36	13.8	.54	25	.98	162	6.38

Dimensions																					
Size d ₀	D ₁																				
	H2 js8		H3		H4		H5		S1		P		Fixing		S2		Self locking nut		High precision nut ³⁾		Tapered pin (hardened) or straight pin
	mm	in	mm	in	mm	in	mm	in	mm	in	mm	in	mm	in	mm	in	mm	in	mm	in	(DIN6325)
16	32	1.26	22	.87	15	.59	8	.31	9	.35	.15	.006	M8 × 35	7.7	.30	18	.71	28	1.10	8 × 40	
20	34	1.34	22	.87	17	.67	8	.31	9	.35	.15	.006	M8 × 35	7.7	.30	21	.83	30	1.18	8 × 40	
25	39	1.54	27	1.06	19	.75	10	.39	11	.43	.2	.008	M10 × 40	9.7	.38	28	1.10	37	1.46	10 × 50	
32	45	1.77	27	1.06	20	.79	10	.39	11	.43	.2	.008	M10 × 40	9.7	.38	32	1.26	40	1.57	10 × 50	
40	58	2.28	32	1.26	23	.91	12	.47	13	.51	.2	.008	M12 × 50	9.7	.38	44	1.73	49	1.92	10 × 50	
50	65	2.56	38	1.50	25	.98	12	.47	13	.51	.2	.008	M12 × 55	9.7	.38	50	1.97	54	2.13	10 × 55	
63	65	2.56	49	1.93	35	1.38	15	.59	13	.51	.2	.008	M12 × 55	9.7	.38	68	2.68	75	2.95	10 × 55	
80	90	3.54	50	1.97	40	1.57	25	.98	17	.67	.2	.008	M16 × 80	11.7	.46	74	2.91	85	3.35	12 × 80	

³⁾ Optional.

Axially Free Plummer Housing with MRC Deep-Groove Ball Bearing

During your selection, compare your application with our bearing load rating. If the capacity is not sufficient, please contact MRC.

The BUF plumber bearing unit consists of:

- bearing housing made of burnished steel, with one reference side ξ
- grease-tight deep-groove MRC ball bearing, greased for life \dot{i}
- retaining ring \neg

In standard version, the “BUF” bearing unit is assembled according to drawing on page 97. If you require a different assembly, please indicate it when ordering.

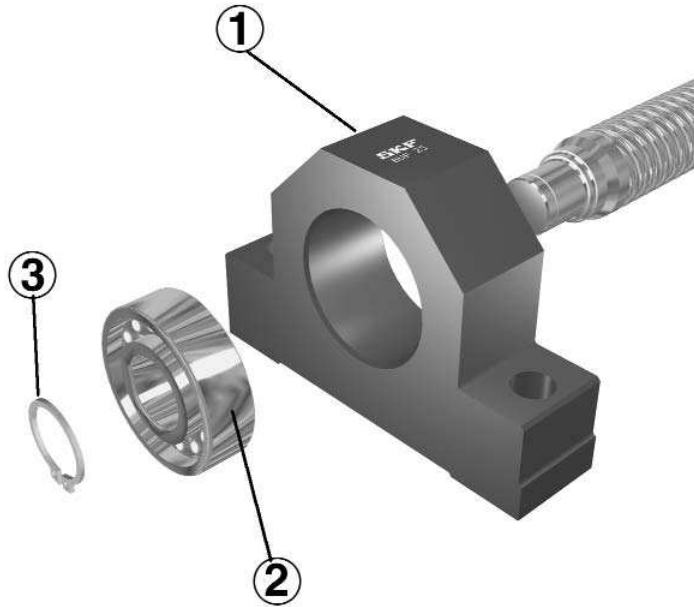

Size d_0 mm	Plummer bearing Unit designation (free)	Deep-groove ball bearing											
		Basic load rating (radial)				MRC bearing designation	Dimensions						Retaining ring (DIN 471)
		Dynamic C_a		Static C_{oa}			d		D		B		
		kN	lbf	kN	lbf		mm	in	mm	in	mm	in	
16	BUF16	5.07	1140	2.36	530	200SZZ	10	.3937	30	1.1811	9	.3543	10 × 1
20	BUF20	5.07	1140	2.36	530	200SZZ	10	.3937	30	1.1811	9	.3543	10 × 1
25	BUF25	9.56	2150	4.75	1070	203SZZ	17	.6693	40	1.5748	12	.4724	17 × 1
32	BUF32	9.56	2150	4.75	1070	203SZZ	17	.6693	40	1.5748	12	.4724	17 × 1
40	BUF40	19.5	4380	11.2	2520	206SZZ	30	1.1811	62	2.4409	16	.6299	30 × 1.5
50	BUF50	19.5	4380	11.2	2520	206SZZ	30	1.1811	62	2.4409	16	.6299	30 × 1.5
63	BUF63	33.2	7460	21.6	4670	209SZZ	45	1.7717	85	3.3465	19	.7480	45 × 1.75
80	BUF80	33.2	7460	21.6	4670	209SZZ	45	1.7717	85	3.3465	19	.7480	45 × 1.75

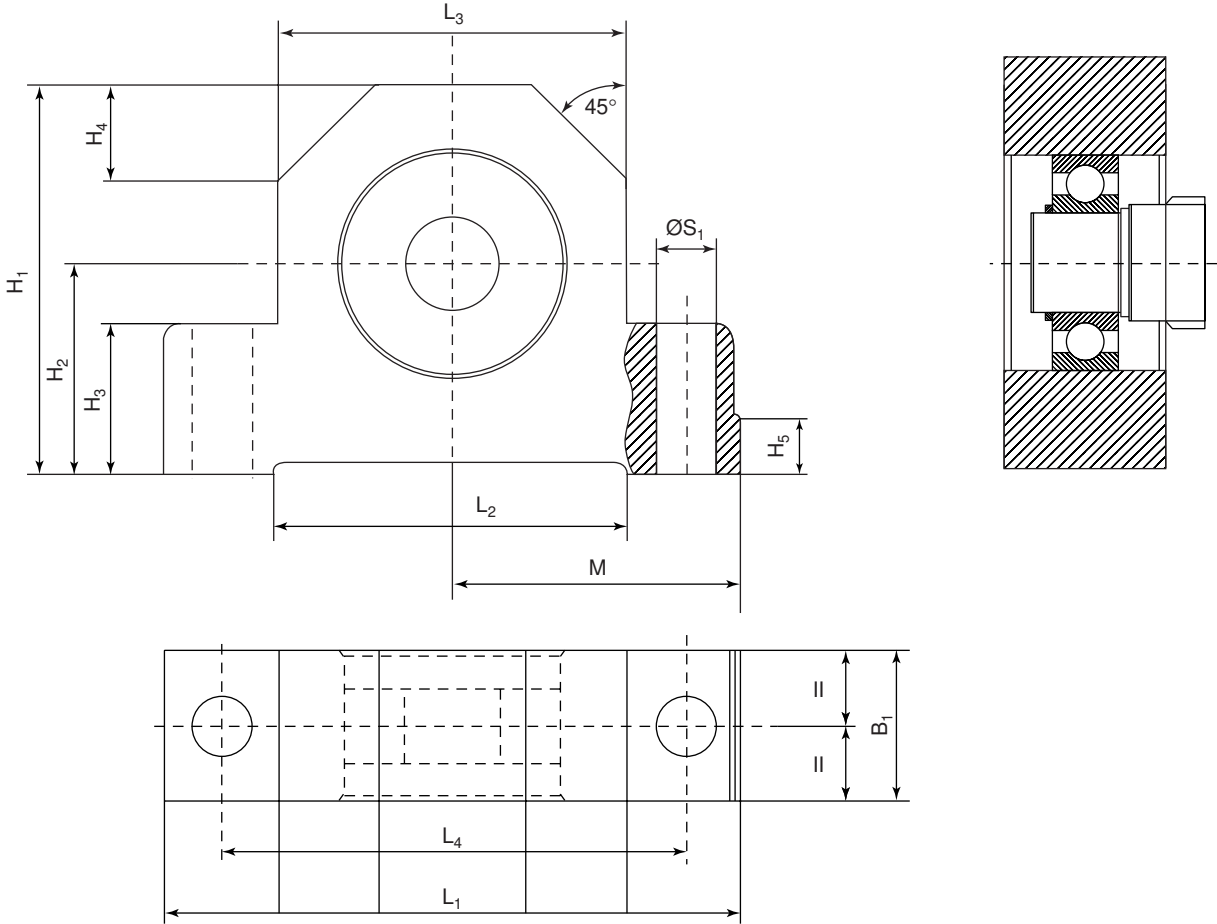

Dimensions													
Size d ₀ mm	L ₁		L ₂		L ₃		L ₄		M		B ₁		
	js8												
	mm	in	mm	in	mm	in	mm	in	mm	in	mm	in	
16	86	3.38	52	2.05	52	2.05	68	2.68	43	1.69	24	.94	
20	94	3.70	52	2.05	60	2.36	77	3.03	47	1.85	26	1.02	
25	108	4.25	65	2.56	66	2.60	88	3.46	54	2.13	28	1.10	
32	112	4.41	65	2.56	70	2.76	92	3.62	56	2.20	34	1.34	
40	126	4.96	82	3.23	80	3.15	105	4.13	63	2.48	38	1.50	
50	144	5.67	80	3.15	92	3.62	118	4.65	72	2.83	39	1.54	
63	190	7.48	110	4.33	130	5.12	160	6.30	95	3.74	38	1.50	
80	205	8.07	120	4.72	145	5.71	175	6.89	102.5	4.04	40	1.57	

Dimensions (cont.)													
Size d ₀ mm	H ₁		H ₂		H ₃		H ₄		H ₅		S ₁		Fixing screws
	js8		js8								H ₁₂		
	mm	in	mm	in	mm	in	mm	in	mm	in	mm	in	
16	58	2.28	32	1.26	22	.87	15	.59	8	.31	9	.35	M8 × 35
20	64	2.52	34	1.34	22	.87	17	.67	8	.31	9	.35	M8 × 35
25	72	2.83	39	1.54	27	1.06	19	.75	10	.63	11	.43	M10 × 40
32	77	3.03	45	1.77	27	1.06	20	.79	10	.63	11	.43	M10 × 40
40	98	3.86	58	2.28	32	1.26	23	.91	12	.47	13	.51	M12 × 50
50	112	4.41	65	2.56	38	1.50	25	.98	12	.47	13	.51	M12 × 55
63	130	5.12	65	2.56	49	1.93	35	1.38	15	.59	13	.51	M12 × 65
80	162	6.38	90	3.54	50	1.97	40	1.57	25	.98	17	.67	M16 × 80

1. Dynamic load rating (N) and Basic life rating

$$L_{10} = \left(\frac{C_a}{F_m}\right)^3 \text{ or } C_{req} = F_m (L_{10})^{1/3}$$

L_{10} = life (million of revolutions)
 C_a = basic dynamic load rating
 C_{req} = required dynamic load rating
 F_m = cubic mean load (N)

2. Cubic mean load (N)

$$F_m = \frac{(F_1^3 L_1 + F_2^3 L_2 + F_3^3 L_3 + \dots)^{1/3}}{(L_1 + L_2 + L_3 + \dots)^{1/3}}$$

$$F_m = \frac{F_{min} + 2F_{max}}{3}$$

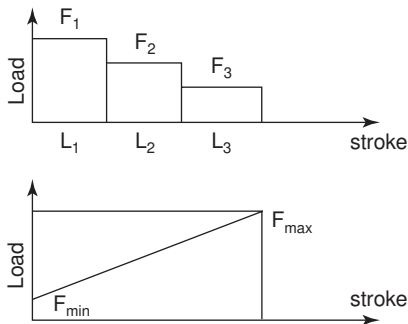

3. Critical speed of screw shaft (no safety factor) (rpm) (a factor of 0.8 is generally recommended)

$$n_{cr} = 490 \cdot 10^5 \cdot \frac{f_1 d_2}{l^2}$$

d_2 = root diameter (mm)
 l = free length, or distance between the two support bearings
 f_1 = 0.9 ●●—— fixed, free
 3.8 ●●——● fixed, supported
 5.6 ●●——●● fixed, fixed

4. Speed limit of the mechanism (maximum speed applied through very short periods—to be confirmed, depending on the application)

For instance: $n \times d_0 < 100\,000$, to the exception of long leads: $32 \times 20/25/32 - 40 \times 40 - 50 \times 50$ and 63×50 :
 $n \times d_0 < 70\,000$, if higher, please consult MRC

n = revolutions per minute
 d_0 = screw shaft nominal diameter

5. Buckling strength (with a safety factor: 3) (N)

$$F_c = \frac{34000 \cdot f_3 \cdot d_2^4}{l^2}$$

d_2 = root diameter (mm)
 l = free length, or distance between the two support bearings
 f_3 = mounting correction factor
 0.25 ●●—— fixed, free
 1 ●●——● supported, supported
 2 ●●——●● fixed, supported
 4 ●●——●● fixed, fixed

6. Rigidity. The total rigidity of a screw is:

$$R_t = \frac{F}{\delta}$$

$$\frac{1}{R_t} = \frac{1}{R_s} + \frac{1}{R_n}$$

F = load
 δ = deflection
 R_s = screw shaft rigidity
 R_n = nut rigidity

The rigidity of a screw shaft is:

- Ball screw held rigidity at one end:

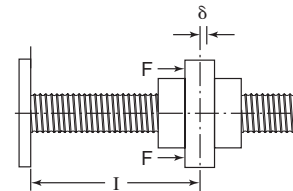

$$R_s = 165 \frac{d_2^2}{l} \text{ (N/}\mu\text{m)}$$

for standard steel

- Ball screw held rigidly at both ends:

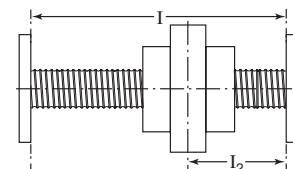

$$R_s = \frac{165 d_2^2 I}{I_2 (I - I_2)}$$

for standard steel

7. Theoretical efficiency

- direct (η)

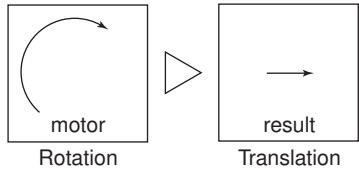

$$\eta = \frac{1}{1 + \frac{K \cdot d_0}{P_h}}$$

$$K = 0.018$$

d_0 = nominal diameter of screw shaft

P_h = lead (mm)

- indirect (η')

$$\eta^1 = 2 - \frac{1}{\eta}$$

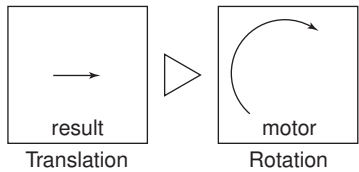

8. Practical efficiency (η_p)

$$\eta_p = \eta \cdot 0.9$$

The value 0.9 used is an average value between the practical efficiency of a new screw and that of a properly run in screw. It should be used for industrial applications in all normal working conditions. For extreme cases, call us.

9. Input torque in a steady state (Nm)

$$T = \frac{F \cdot P_h}{2000 \cdot \pi \cdot \eta_p}$$

F = maximum load of the cycle (N)

P_h = lead (mm)

η_p = practical efficiency

n = revolutions per minute

10. Power required in a steady state (W)

$$P = \frac{F \cdot n \cdot P_h}{60000 \cdot \eta_p}$$

11. Preload torque (Nm)

$$T_{pr} = \frac{F_{pr} \cdot P_h}{1000 \cdot \pi} \left(\frac{1}{\eta_p} - 1 \right)$$

F_{pr} = preload force between a nut and the shaft (N)

12. Restraining torque (Nm) (considering system back-driving)

$$T_B = \frac{F \cdot P_h \cdot \eta'}{2000 \cdot \pi}$$

F = load

For safety, we can use the theoretical indirect efficiency

η' = indirect efficiency

13. Nominal motor torque when accelerating (Nm)

For a horizontal screw

$$T_t = T_f + T_{pr} + \frac{P_h [F + m_L \cdot \mu_f \cdot g]}{2000 \cdot \pi \cdot \eta_p} + \dot{\omega} \Sigma I$$

For a vertical screw

$$T_t = T_f + T_{pr} + \frac{P_h [F + m_L \cdot g]}{2000 \cdot \pi \cdot \eta_p} + \dot{\omega} \Sigma I$$

T_f = torque from friction in support bearings, motors, seals, etc... (Nm)

T_{pr} = preload torque

μ_f = coefficient of friction

η_p = real direct efficiency

$\dot{\omega}$ = angular acceleration

m_L = mass of the load (kg)

g = acceleration of gravity (9.8 m/s²)

$\Sigma I = I_M + I_L + I_S \cdot 10^{-9}$

14. Nominal braking torque when decelerating (Nm)

For a horizontal screw

$$T'_t = T_f + T_{pr} + \frac{P_h \cdot \eta^1 \cdot [F + m_L \cdot \mu_f \cdot g]}{2000 \cdot \pi} + \dot{\omega} \Sigma I$$

For a vertical screw

$$T_t = T_f + T_{pr} + \frac{P_h \cdot \eta^1 \cdot [F + m_L \cdot g]}{2000 \cdot \pi} + \dot{\omega} \Sigma I$$

$$I_L = m_L \left(\frac{P_h}{2\pi} \right)^2 10^{-6}$$

η^1 = theoretical indirect efficiency

I_M = inertia of motor (kgm²)

I_S = inertia of screw shaft per meter (kgmm²/m)

l = length of screw shaft (mm)

For additional information, please contact MRC.

Profile Rail Guides

Section VIII



Profile rail guides from MRC are modern machine components used in the production of linear guidance systems with unlimited travel. They usually consist of a profile rail with four precision-ground raceways and a slide unit with four ball circulation paths. This design offers numerous benefits. The square configuration of the raceways results in a guidance system with good rigidity, capable of withstanding moment loads in all directions. The load carrying capacity is equal in all four directions (fig 1). Ready-to-mount units guarantee economy and simplicity of mounting. Installation and adjustment procedures are reduced to a minimum. The design of the system is such that inaccuracies of the adjacent components can be accommodated. MRC profile rail guides are noted for their ease of main-

tenance and reliability. They are provided as standard with grease nipple and all-round seals. The two-point contact of the rolling elements with the raceways permit high operational speeds with quiet running and low coefficient of friction. Good running accuracy is assured throughout the operational life of the system. Guides with specific preload can be supplied for special requirements. This is achieved through selection. The choice of preload is dependent on the load carrying and stiffness specifications.

To meet the widest possible range of customer demands, MRC offers seven different series of profile rail guides. Table 1 shows basic data for the various models.

Table 1 Product Review

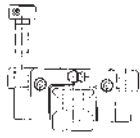
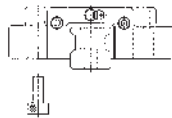
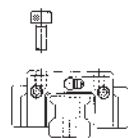
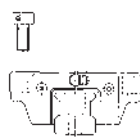
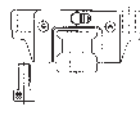
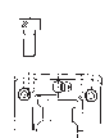
Classification	High performance profile rail guides			Heavy duty profile rail guides		
	LLBHS..TA	LLBHS..TB	LLBHS..TR	LLBHS..A	LLBHS..B	LLBHS..R
Type						
Slide unit fixing						
Velocity m/min	200	200	200	120	120	120
Acceleration m/s ²	100	100	100	80	80	80
Tolerances	P001-P5	P001-P5	P001-P5	P001-P5	P001-P5	P001-P5
Preload	T-T3	T-T3	T-T3	T-T3	T-T3	T-T3
Vibration	•	•	•	◦	◦	◦
Noise	•	•	•	◦	◦	◦
Coefficient of friction	0.003–0.005					
Heat resistance	Up to 80°C (176°F); with special insulation up to 100°C (212°F)					
Corrosion resistance	Hard chrome coating; Raydent coating					
Lubrication	Lithium based grease, e.g. SKF LGM 2, for each 100 km of travel or six-monthly					
Seals	In addition to standard seals, covers wipers and bellows are also available					

◦ low
• very low

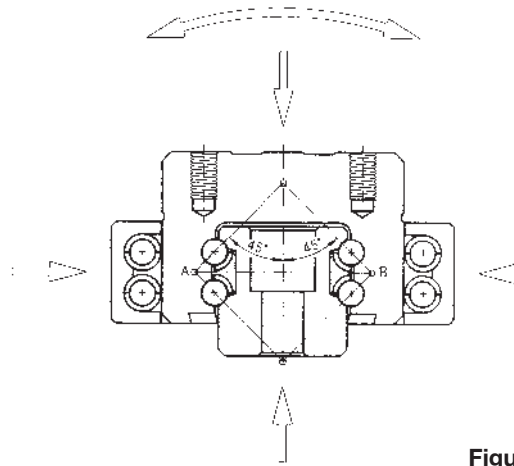

Figure 1

High load profile rail guides (long slide unit)			Compact and medium load profile rail guides			M-Type profile rail guides	Miniature profile rail guides*
LLBHS..LA	LLBHS..LB	LLBHS..LR	LLBUS..R	LLBUS..SR	LLBNS..TR	LLBMS..TW/TC	LLMHS..TA
120	120	120	120	120	200	200	180
80	80	80	80	80	100	100	80
P001-P5	P001-P5	P001-P5	P001-P5	P001-P5	P001-P5	P001-P5	P1-5
T-T3	T-T3	T-T3	T-T3	T-T3	T-T3	—	T0, T1
○	○	○	○	○	●	●	●
○	○	○	○	○	●	●	●

* All stainless steel

Profile rail guides from MRC are available in five tolerance classes. These are defined in the adjacent table and are applicable to all kinds of profile rail guides excluding the miniature range.

Dimensional Tolerance of Height “H”

This refers to the maximum variation of the dimension “H” for a slide unit on a profile rail guide (table 1).

Dimensional Tolerance of Width “N”

This refers to the maximum variation of the dimension “N” for a slide unit on a profile rail guide (table 1).

- Dimension “N” is defined as the distance between the ground datum face of the rail and the ground datum side of the slide unit. The datum side of the rail is marked with a groove.
- Tolerances listed here are average values measured at the middle point of the slide unit.
- Tolerances should be checked again after mounting the rail guide on the machine.
- With paired profile rail guides of P5 tolerance, only low values of preload should be used, depending on the rail length (fig 1).

Table 1 System Accuracy							
Dimension	Class		P001	P01	P1	P3	P5
Height H	Dimensional variation	in	±.0002	±.004	±.0008	±.0016	±.0031
		mm	±.005	±.010	±.020	±.040	±.080
	between paired rails	in	.0001	.0002	.0003	.0006	.0010
		mm	.003	.005	.007	.015	.025
Width N	Dimensional variation	in	±.0003	±.0006	±.0010	±.0020	±.0039
		mm	±.008	±.015	±.025	±.050	±.100
	between paired rails	in	.0001	.0003	.0004	.0008	.0012
		mm	.003	.007	.010	.020	.030

Dimensions in inches (shaded) and millimeters.

Parallelism

The running accuracy is defined as the variation in the dimensions H and N over the length of the rail (Fig 1, Table 2).

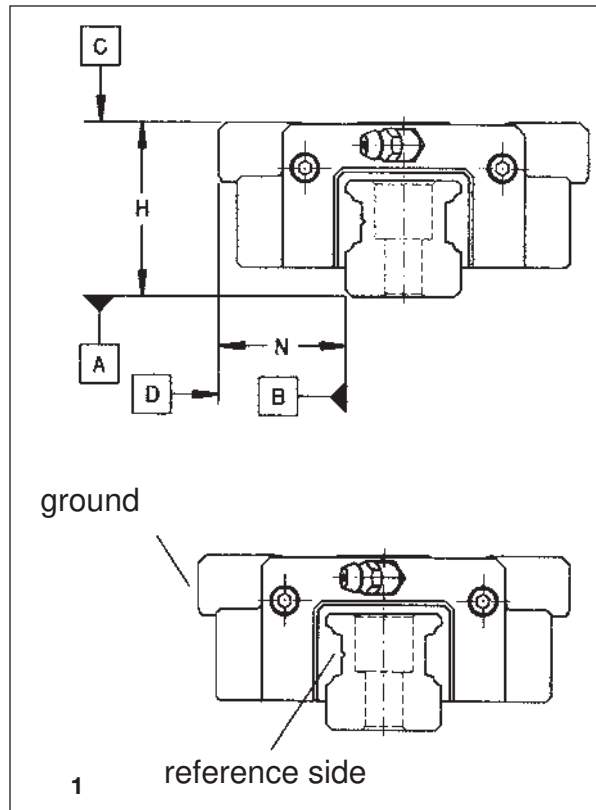

Table 2 Parallelism

Grades		Parallelism of plane C to datum plane A Parallelism of plane D to datum plane B									
Rail track length (mm)		P001		P01		P1		P3		P5	
over	up to	mm	in	mm	in	mm	in	mm	in	mm	in
—	315	.0015	.00006	.002	.00008	.0025	.00010	.008	.00031	.016	.00063
315	400	.002	.00008	.002	.00010	.0035	.00014	.010	.00039	.020	.00079
400	500	.002	.00008	.003	.00012	.0045	.00018	.011	.00043	.024	.00094
500	630	.002	.00008	.0035	.00014	.006	.00024	.014	.00055	.027	.0011
630	800	.0025	.00010	.004	.00016	.008	.00031	.016	.00063	.032	.0013
800	1000	.003	.00012	.0045	.00018	.009	.00035	.019	.00075	.038	.0015
1000	1250	.003	.00012	.006	.00024	.011	.00043	.022	.00087	.043	.0017
1250	1600	.004	.00016	.007	.00028	.014	.00055	.025	.0010	.050	.0020
1600	2000	.0045	.00018	.008	.00031	.016	.00063	.029	.0011	.057	.0022
2000	2500	.006	.00024	.009	.00035	.018	.00071	.030	.0012	.060	.0024
2500	3000	.006	.00024	.010	.00039	.018	.00071	.030	.0012	.060	.0024

Accuracy Recommendations

The tolerance class should be selected according to the required positioning accuracy of the machine itself. Typical accuracies for various applications are shown in table 3.

Table 3 Accuracy recommendations								
Accuracy		P001	P01	P1	P3	P5		
NC Machines	Lathes	x	◦	◦	◦	◦		
		z				◦	◦	
	Machining centers	x			◦	◦		
		y			◦	◦		
		z			◦	◦	◦	
	Grinding machines	x	◦	◦	◦			
		z			◦	◦		
	EDM	x			◦	◦		
		y			◦	◦		
		z			◦	◦		
	Punching machines					◦	◦	
	Semiconductor manufacture		◦	◦	◦			
	General industrial machinery			◦	◦			

For the smooth running and long operational life of profile rail guides, the quality of the installation and of the mounting surfaces is of great importance. The following tables show the tolerances for parallelism of the rails.

Mounting accuracy	Permissible deviation from parallelism e 1								Permissible height deviation e 2							
	T0		T1		T2		T3		T0		T1		T2		T3	
	mm	in	mm	in	mm	in	mm	in	mm	in	mm	in	mm	in	mm	in
LLBHS15TA/TB/TR	.019	.00075	.013	.0005	.010	.0004	.009	.00035								
LLBHS20TA/TB	.023	.0009	.017	.0007	.014	.00055	.011	.0004								
LLBHS25TA/TB/TR	.029	.0011	.021	.0008	.017	.0007	.014	.00055								
LLBHS30TA/TB/TR	.035	.0014	.025	.0010	.020	.0008	.016	.0006	.15	.0059	.075	.0030	.050	.0020	.040	.0016
LLBHS35TA/TB/TR	.040	.0016	.029	.0011	.023	.0009	.019	.00075								
LLBHS45TA/TB/TR	.052	.00205	.038	.0015	.029	.0011	.024	.00095								
LLBHS55TA/TB/TR	.062	.0024	.046	.0018	.036	.0014	.030	.0012								
LLBHS65TA/TB/TR	.081	.0032	.059	.0023	.046	.0018	.038	.0015								
LLBHS15A/B	.019	.00075	.013	.0005	.010	.0004	.009	.00035								
LLBHS20A/B/R	.023	.0009	.017	.0007	.014	.00055	.011	.0004								
LLBHS25A/B/R	.029	.0011	.021	.0008	.017	.0007	.014	.00055								
LLBHS30A/B/R	.035	.0014	.025	.0010	.020	.0008	.016	.0006	.15	.0059	.075	.0030	.050	.0020	.040	.0016
LLBHS35A/B/R	.040	.0016	.029	.0011	.023	.0009	.019	.00075								
LLBHS45A/B/R	.052	.00205	.038	.0015	.029	.0011	.024	.00095								
LLBHS55A/B/R	.062	.0024	.046	.0018	.036	.0014	.030	.0012								
LLBHS65A/B/R	.081	.0032	.059	.0023	.046	.0018	.038	.0015								
LLBHS25LA/LB/LR	.027	.0011	.020	.0008	.016	.0006	.013	.0005								
LLBHS30LA/LB/LR	.032	.0013	.024	.00095	.019	.00075	.015	.0006								
LLBHS35LA/LB/LR	.037	.0015	.027	.0011	.021	.0008	.018	.0007	.15	.0059	.075	.0030	.050	.0020	.040	.0016
LLBHS45LA/LB/LR	.049	.0019	.036	.0014	.028	.0011	.023	.0009								
LLBHS55LA/LB/LR	.050	.0020	.044	.0017	.034	.0013	.028	.0011								
LLBHS65LA/LB/LR	.075	.0030	.055	.0022	.043	.0017	.035	.0014								

Permissible deviation from parallelism e 1

Permissible height deviation e 2

Mounting accuracy

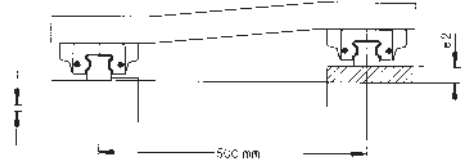
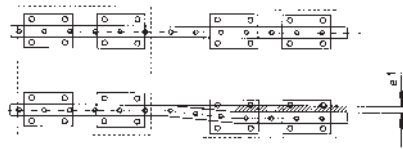

Preload Type	T0		T1		T2		T3		T0		T1		T2		T3	
	mm	in	mm	in	mm	in	mm	in	mm	in	mm	in	mm	in	mm	in
LLBNS 15TR	.013	.0005	.010	.0004	.008	.0003	.006	.0002								
LLBNS 20TR	.018	.0007	.013	.0005	.011	.0004	.009	.00035								
LLBNS 25TR	.024	.00095	.017	.0007	.013	.0005	.011	.0004								
LLBNS 30TR	.029	.0011	.021	.0008	.016	.0006	.014	.00055	.120	.0047	.055	.0022	.040	.0016	.030	.0012
LLBNS 40TR	.041	.0016	.030	.0012	.023	.0009	.019	.00075								
LLBNS 50TR	.052	.00205	.038	.0015	.030	.0012	.025	.0010								
LLBUS 15R	.019	.00075	.013	.0005	.010	.0004	.009	.00035								
LLBUS 20R	.023	.0009	.017	.0007	.014	.00055	.011	.0004								
LLBUS 25R	.029	.0011	.021	.0008	.017	.0007	.014	.00055								
LLBUS 30R	.035	.0014	.025	.0010	.020	.0008	.016	.0006	.150	.0059	.075	.0030	.050	.0020	.040	.0016
LLBUS 35R	.040	.0016	.029	.0011	.023	.0009	.019	.00075								
LLBUS 45R	.052	.00205	.038	.0015	.029	.0011	.024	.00095								
LLBUS 55R	.062	.0024	.046	.0018	.036	.0014	.030	.0012								
LLBUS 15SR	.021	.0008	.016	.0006	.013	.0005	.010	.0004								
LLBUS 20SR	.027	.0011	.020	.0008	.016	.0006	.013	.0005								
LLBUS 25SR	.033	.0013	.024	.00095	.019	.00075	.016	.0006								
LLBUS 30SR	.040	.0016	.029	.0011	.023	.0009	.019	.00075	.150	.0059	.075	.0030	.050	.0020	.040	.0016
LLBUS 35SR	.045	.0018	.033	.0013	.026	.0010	.021	.0008								

For trouble-free operation under different and widely varying operational conditions, it is necessary to determine the appropriate preload. In most instances a light or moderate preload is recommended. For certain cases where high impact loads or vibrations occur, a higher preload is advisable. Tables 1 and 2 show the recommended preload classes for profile rail guides.

In order not to lose the effect of the preload, the magnitude of the load on the bearing should not exceed three times that of the preload.

The higher the preload, the greater the stiffness.

Diagram 1 shows the qualitative effect of preload on the relationship between load and deformation. It will be seen that a preloaded system can have a stiffness 2.8 times greater than that of a non-preloaded system, i.e. the elastic deformation can be reduced by at least one half.

In selecting a profile rail guide, it is of importance to know the exact preload value (see Linear Guidance Systems Handbook for calculation of operational life). Table 2 shows the preload values for each class.

Table 1			
Type of preload		Conditions of use	Application
Heavy preload	T3	Heavy cutting or forming work with heavy impact and vibration.	Machining centers. Milling machines.
	T2	Alternating load.	Vertical axes of machine tools.
Medium preload	T1	Medium cutting or forming work with medium impact and vibration.	Surface grinding machines. Robots. Laser Processing machines.
		Light overhung load or alternate load applied.	Light-duty drilling machines. High speed punching machines.
Light preload	T0	Precise movement with only light vibration and no alternating load.	Precision positioning tables. Tables for optical measuring equipment. Automatic tool changer for machining centers. Welding machines. Handling equipment.
Without preload	T	Extreme temperature variation; no need for high precision.	Tool changers. Feeding devices. Plasma cutting equipment.

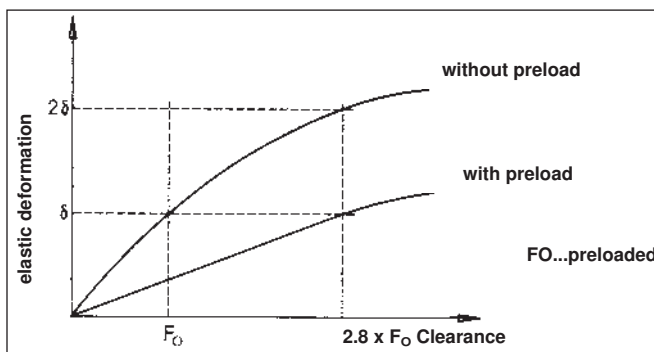

Diagram 1

Table 2 Preload	
T	0.02 mm Clearance
T0	0
T1	0.04 · C
T2	0.08 · C
T3	0.12 · C

Designations

Profile rail guides from MRC are manufactured in a variety of types and sizes to suit particular applications.

When ordering please specify requirements in accordance with the following chart.

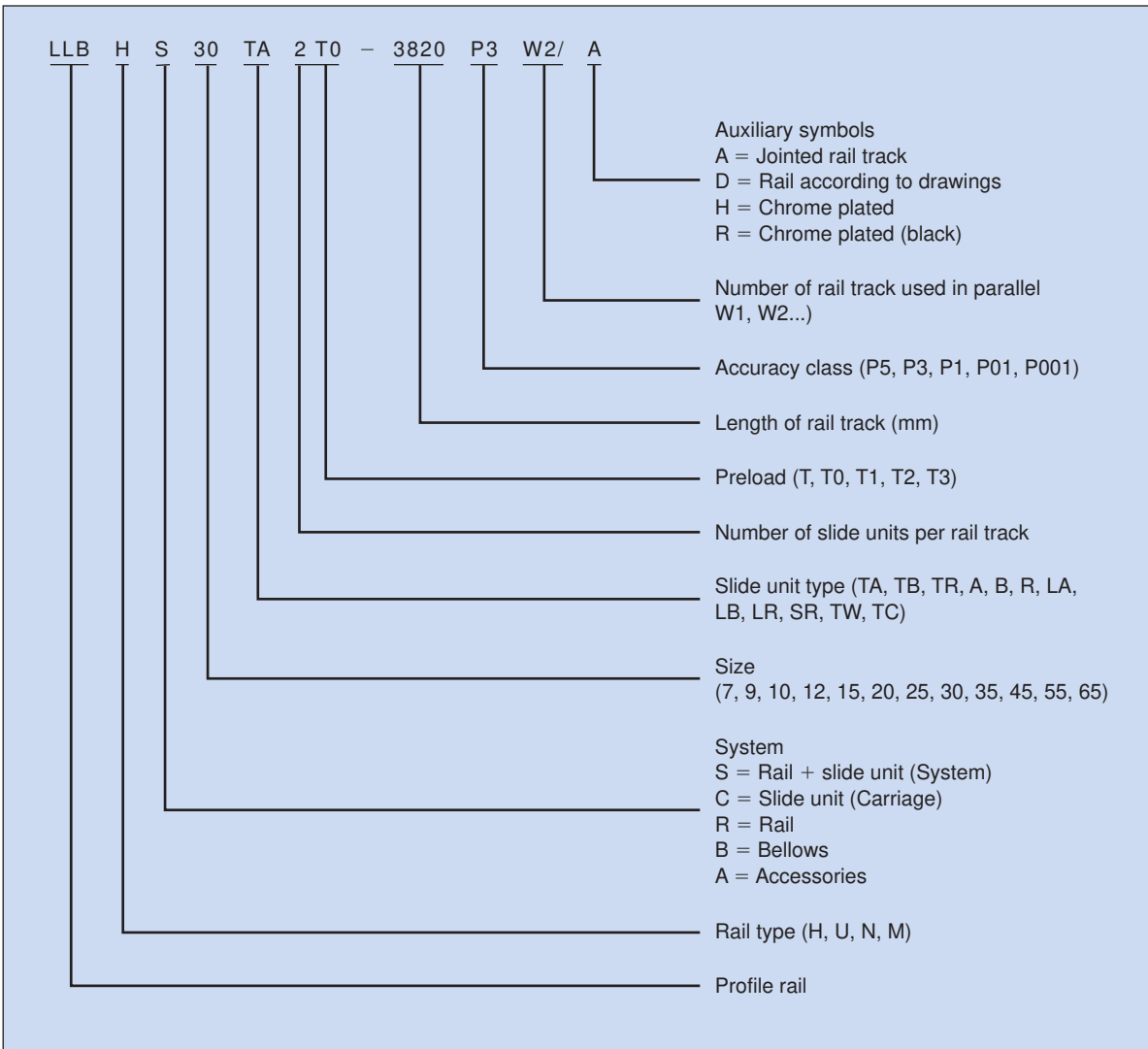

Notes

LLBHS..TA
LLBHS..TB
LLBHS..TR

The special design of the raceway and ball circulation unit of the MRC High Performance range of profile rail guides results in the optimum combination of high load carrying capacity, low friction and exceptionally quiet running at high speeds.

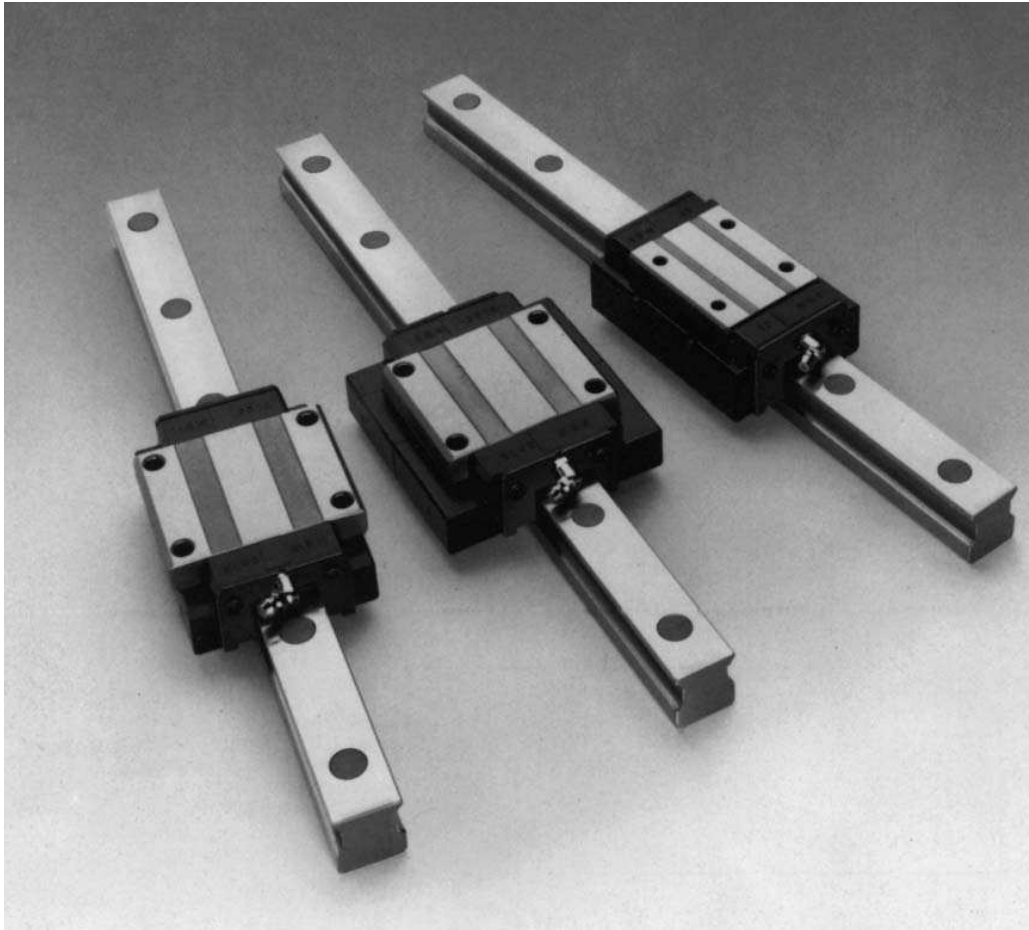

The use of four raceways set at 90° to each other results in a rigid system with equal load carrying capacity in all directions.

The exceptionally large radius of the ball recirculation path enables the achievement of high operational speeds at a particularly low noise level (see fig 2).

In contrast to other systems, profile rail guides from MRC use the principle of two-point contact which reduces differential slip or spin to a minimum. Even where there is high preload there is only a slight increase in friction (fig 1).

Standard Length

The rails high performance profile rail guides are produced in different maximum lengths (see Table 1).

Longer lengths can be achieved by putting together separate pieces.

Rails are generally manufactured with a symmetrical hole pattern. Where this is not possible, dimension E is defined as the distance between the end of the rail and the center of the last mounting hole.

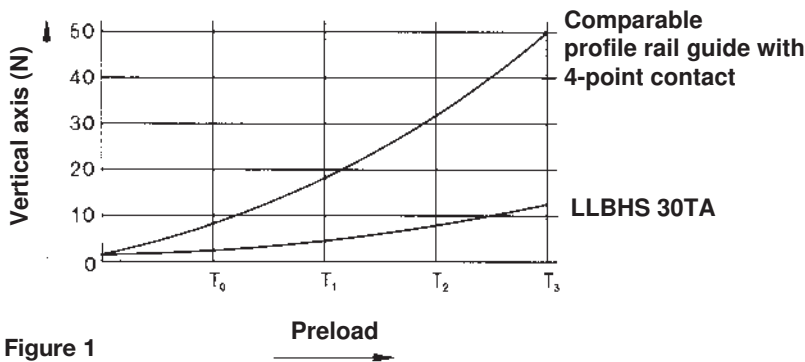
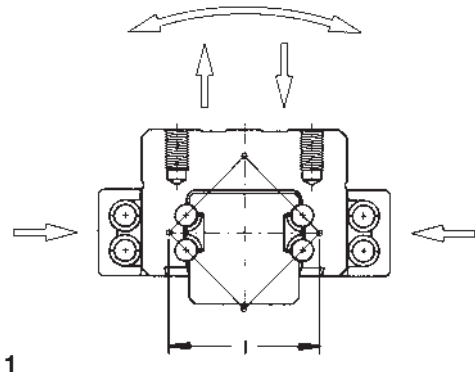
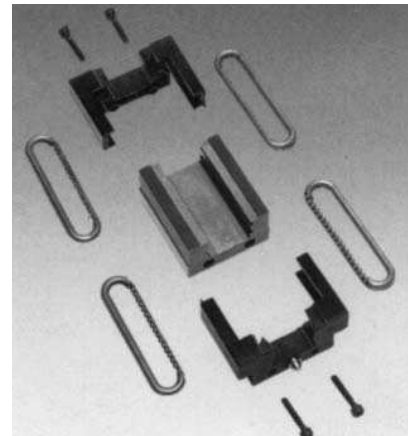

Figure 1



2

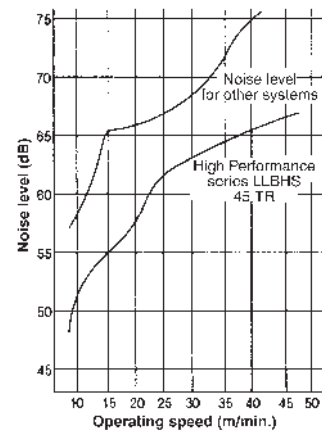
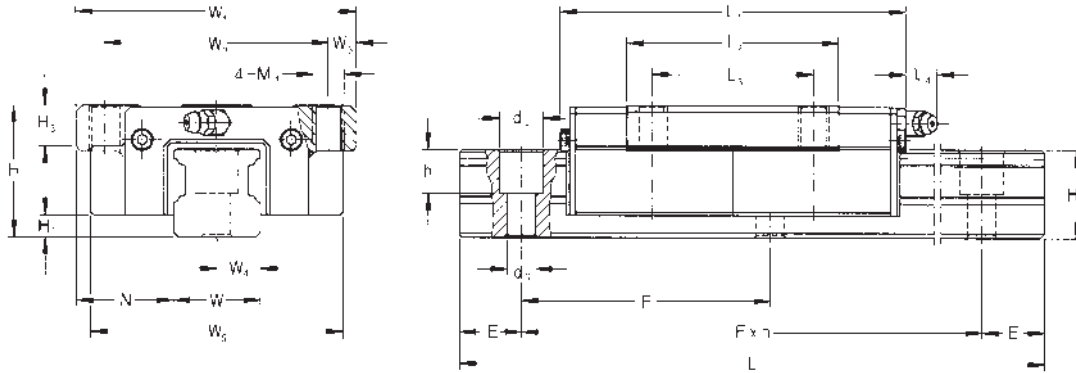

Figure 2

Table 1 Maximum rail length

Size	Max. length (mm)
LLBHR 15	1500
LLBHR 20	3000
LLBHR 25	3000
LLBHR 30	3000
LLBHR 35	3000
LLBHR 45	3000
LLBHR 55	3000
LLBHR 65	3000

LLBHS..TA



Model no.	System dimensions						Side unit					
	H		H ₁		N		W ₁		W ₂		W ₃	
	mm	in	mm	in	mm	in	mm	in	mm	in	mm	in
LLBHS 15TA	24	.94	4.6	.18	16	.63	47	1.85	38	1.50	4.5	.18
LLBHS 20TA	30	1.18	5	.20	21.5	.85	63	2.48	53	2.09	5.	.20
LLBHS 25TA	36	1.42	6.5	.26	23.5	.93	70	2.76	57	2.24	6.5	.26
LLBHS 30TA	42	1.65	7	.28	31	1.22	90	3.54	72	2.83	9	.35
LLBHS 35TA	48	1.89	8	.31	33	1.30	100	3.94	82	3.23	9	.35
LLBHS 45TA	60	2.36	11	.43	37.5	1.48	120	4.72	100	3.94	10	.39
LLBHS 55TA	75	2.95	14	.55	43.5	1.71	140	5.51	116	4.57	12	.47
LLBHS 65TA	85	3.35	14.	.55	53.5	2.11	170	6.69	142	5.59	14.	.55

Model no.	Slide unit (cont)										M ₁		
	W ₅		L ₁		L ₂		L ₃		L ₄			H ₂	
	mm	in	mm	in	mm	in	mm	in	mm	in		mm	in
LLBHS 15TA	46.5	1.83	71	2.80	41	1.61	30	1.18	0	0	7	.28	M5 × 7
LLBHS 20TA	60	2.36	91	3.58	58	2.28	40	1.57	0	0	8	.31	M6 × 10
LLBHS 25TA	66	2.60	97	3.82	59	2.32	45	1.77	10	.39	10	.39	M8 × 12
LLBHS 30TA	81	3.19	111	4.37	68	2.68	52	2.05	10	.39	13	.51	M10 × 14
LLBHS 35TA	92	3.62	128	5.04	80	3.15	62	2.44	10	.39	13	.51	M10 × 16
LLBHS 45TA	112	4.41	158	6.22	102	4.02	80	3.15	12	.47	15	.59	M12 × 19
LLBHS 55TA	130	5.12	189	7.44	124	4.88	95	3.74	12	.47	17	.67	M14 × 23
LLBHS 65TA	162.	6.38	225	8.86	148	5.83	110	4.33	12	.47	20	.79	M16 × 29

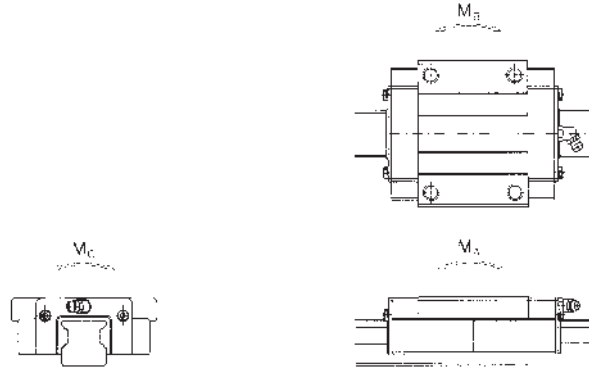

Rail												Load rating ¹⁾			
W		W ₄		H ₄		d ₂		d ₃		h		F		C	
mm	in	mm	in	mm	in	mm	in	mm	in	mm	in	mm	in	N	lbf
15	.59	7.5	.29	17	.67	7.5	.29	4.5	.18	7	.28	60	2.36	7350	1650
20	.79	10	.39	21	.83	9.5	.37	6	.24	11	.43	60	2.36	12900	2900
23	.91	11.5	.45	24	.94	11	.43	7	.28	11	.43	60	2.36	17000	3820
28	1.10	14	.55	28	1.10	14	.55	9	.35	14	.55	80	3.15	23600	5310
34	1.34	17	.67	32	1.26	14	.55	9	.35	15	.59	80	3.15	31500	7080
45	1.77	22.5	.86	42	1.65	20	.79	14	.55	21	.83	105	4.13	48000	10800
53	2.09	26.5	1.04	48	1.89	23	.91	16	.63	24	.94	120	4.72	75000	16900
63	2.48	31.5	1.24	58	2.28	26	1.02	18	.71	25	.98	150	5.91	114000	25600

mm	Load rating ¹⁾ (cont.)		Torque moment						Weight			
	C ₀		M _A		M _B		M _C		Slide unit		Rail	
	N	lbf	Nm	lbf-ft	Nm	lbf-ft	Nm	lbf-ft	kg	lb	kg/m	lb/ft
15	11600	2610	70	52	70	52	110	81	.2	.44	1.7	1.14
20	20800	4680	190	140	190	140	260	192	.4	.88	2.8	1.88
23	26000	5840	240	177	240	177	380	280	.6	1.32	3.7	2.49
28	35500	7980	390	288	390	288	610	450	1.0	2.20	5.3	3.56
34	46500	10500	580	428	580	428	960	708	1.5	3.31	7.5	5.04
45	72000	16200	1130	833	1130	833	1960	1450	1.7	5.95	12.9	8.67
53	112200	25200	2240	1650	2240	1650	3570	2630	4.4	9.70	17.3	11.6
63	162800	36600	3780	2880	3780	2880	6290	4640	8.4	18.5	24.9	16.7

¹⁾ All MRC load ratings are based on a cumulative travel of 100.000 m in accordance with DIN 636, Part 2. The dynamic load rating must be multiplied by 1.26 for with comparison with figures based on 50.000 m cumulative travel.

LLBHS..TB

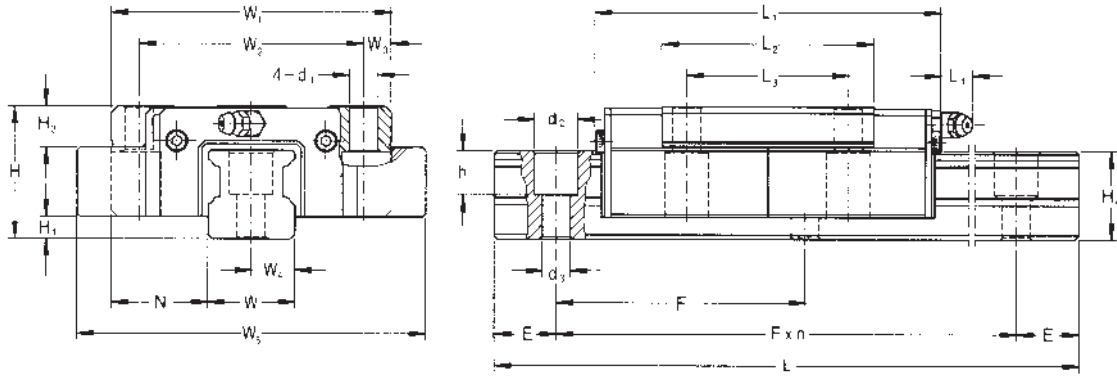

Model no.	System dimensions						Side unit					
	H		H ₁		N		W ₁		W ₂		W ₃	
	mm	in	mm	in	mm	in	mm	in	mm	in	mm	in
LLBHS 15TB	24	.94	4.6	.18	16	.63	47	1.85	38	1.50	4.5	.18
LLBHS 20TB	30	1.18	5	.20	21.5	.85	63	2.48	53	2.09	5	.20
LLBHS 25TB	36	1.42	6.5	.26	23.5	.93	70	2.76	57	2.24	6.5	.26
LLBHS 30TB	42	1.65	7	.28	31	1.22	90	3.54	72	2.83	9	.35
LLBHS 35TB	48	1.89	8	.31	33	1.30	100	3.94	82	3.23	9	.35
LLBHS 45TB	60	2.36	11	.43	37.5	1.48	120	4.72	100	3.94	10	.39
LLBHS 55TB	70	2.76	14	.55	43.5	1.71	140	5.51	116	4.57	12	.47
LLBHS 65TB	85	3.35	14	.55	53.5	2.11	170	6.69	142	5.59	14	.55

Model no.	Slide unit (cont)												
	W ₅		L ₁		L ₂		L ₃		L ₄		H ₃		d ₁
	mm	in	mm	in	mm	in	mm	in	mm	in	mm	in	mm
LLBHS 15TB	60	2.36	71	2.80	41	1.61	30	1.13	0	0	5	.20	4.5 × 7
LLBHS 20TB	79	3.11	91	3.58	58	2.28	40	1.57	0	0	8	.31	6 × 10
LLBHS 25TB	89	3.50	97	3.82	59	2.32	45	1.77	10	.39	10	.39	7 × 12
LLBHS 30TB	112	4.41	111	4.37	68	2.68	52	2.05	10	.39	11	.43	9 × 14
LLBHS 35TB	123	4.84	128	5.04	80	3.15	62	2.44	10	.39	13	.51	9 × 16
LLBHS 45TB	147	5.79	158	6.22	102	4.02	80	3.15	12	.47	15	.59	11 × 19
LLBHS 55TB	171	6.73	189	7.44	124	4.88	95	3.74	12	.47	17	.67	14 × 23
LLBHS 65TB	207	8.15	225	8.86	148	5.83	110	4.32	12	.47	20	.79	16 × 29

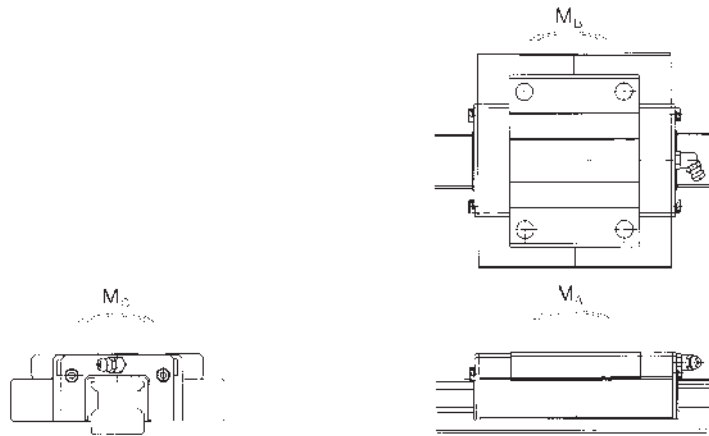

Rail												Load rating ¹⁾			
W		W ₄		H ₄		d ₂		d ₃		h		F		C	
mm	in	mm	in	mm	in	mm	in	mm	in	mm	in	mm	in	N	lbf
15	.59	7.5	.29	17	.67	7.5	.29	4.5	.18	7	.28	60	2.36	7350	1650
20	.79	10	.39	21	.83	9.5	.37	6	.24	11	.43	60	2.36	12900	2900
23	.91	11.5	.45	24	.94	11	.43	7	.28	11	.43	60	2.36	17000	3820
28	1.10	14	.55	28	1.10	14	.55	9	.35	14	.55	80	3.15	23600	5310
34	1.34	17	.67	32	1.26	14	.55	9	.35	15	.59	80	3.15	31500	7080
45	1.77	22.5	.86	42	1.65	20	.79	14	.55	21	.83	105	4.13	48000	10800
53	2.09	26.5	1.04	48	1.89	23	.91	16	.63	24	.94	120	4.72	75000	16900
63	2.48	31.5	1.24	58	2.28	26	1.02	18	.71	25	.98	150	5.91	114000	25600

mm	Load rating ¹⁾ (cont.)		Torque moment						Weight			
	C ₀		M _A		M _B		M _C		Slide unit		Rail	
	N	lbf	Nm	lbf-ft	Nm	lbf-ft	Nm	lbf-ft	kg	lb	kg/m	lb/ft
15	11600	2610	70	52	70	52	110	81	.2	.44	1.7	1.14
20	20800	4680	190	140	190	140	260	192	.4	.88	2.8	1.88
23	26000	5840	240	177	240	177	380	280	.6	1.32	3.7	2.49
28	35500	7980	390	288	390	288	610	450	1.0	2.20	5.3	3.56
34	46500	10500	580	428	580	428	960	708	1.5	3.31	7.5	5.04
45	72000	16200	1130	833	1130	833	1960	1450	2.7	5.95	12.9	8.67
53	112200	25200	2240	1650	2240	1650	3570	2630	4.4	9.70	17.3	11.6
63	162800	36600	3780	2880	3780	2880	6290	4640	8.4	18.5	24.9	16.7

¹⁾ All MRC load ratings are based on a cumulative travel of 100.000 m in accordance with DIN 636, Part 2. The dynamic load rating must be multiplied by 1.26 for with comparison with figures based on 50.000 m cumulative travel.

LLBHS..TR

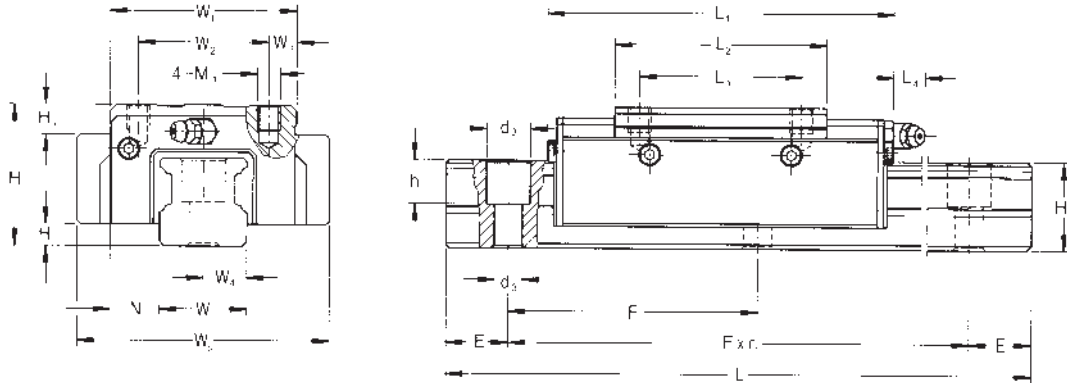

Model no.	System dimensions						Side unit					
	H		H ₁		N		W ₁		W ₂		W ₃	
	mm	in	mm	in	mm	in	mm	in	mm	in	mm	in
LLBHS 15TR	28	1.10	4.6	.18	9.5	.37	34	1.34	26	1.02	4	.16
LLBHS 25TR	40	1.57	6.5	.26	12.5	.44	48	1.89	35	1.38	6.5	.26
LLBHS 30TR	45	1.77	7	.28	16	.63	60	2.36	40	1.57	10	.39
LLBHS 35TR	55	2.17	8	.31	18	.71	70	2.76	50	1.97	10	.39
LLBHS 45TR	70	2.76	11	.43	20.5	.81	86	3.39	60	2.36	13	.51
LLBHS 55TR	80	3.15	14	.55	23.5	.93	100	3.94	75	2.95	12.5	.49
LLBHS 65TR	90	3.54	14	.55	31.5	1.24	126	4.96	90	3.54	18	.71

Model no.	Slide unit (cont)												
	W ₅		L ₁		L ₂		L ₃		L ₄		H ₃		M ₁
	mm	in	mm	in	mm	in	mm	in	mm	in	mm	in	mm
LLBHS 15TR	48	1.89	71	2.80	41	1.61	26	1.02	3	.12	6	.24	M4 × 5
LLBHS 25TR	66	2.60	97	3.82	59	2.32	35	1.38	10	.39	8	.31	M6 × 8
LLBHS 30TR	81	3.19	102	4.02	68	2.32	40	1.57	10	.39	8	.31	M8 × 10
LLBHS 35TR	92	3.62	128	5.04	80	3.15	50	1.97	10	.39	10	.39	M8 × 12
LLBHS 45TR	112	4.41	158	6.22	102	4.02	60	2.36	12	.47	15	.59	M10 × 17
LLBHS 55TR	130	5.12	189	7.44	124	4.88	75	2.95	12	.47	18	.71	M12 × 18
LLBHS 65TR	162	6.38	225	8.86	148	5.83	70	2.76	12	.47	23	.91	M16 × 20

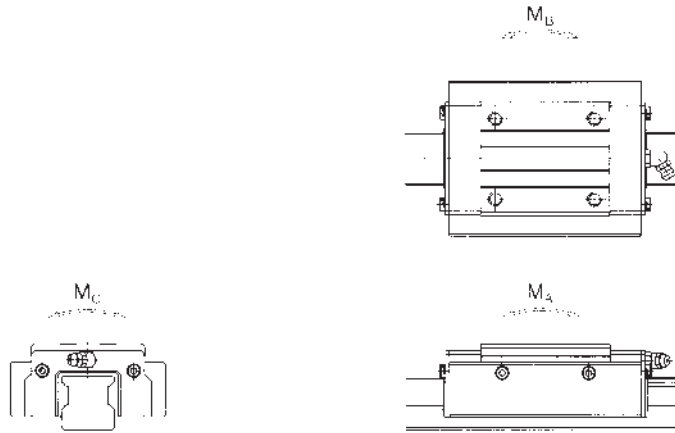

Rail													Load rating ¹⁾		
W		W ₄		H ₄		d ₂		d ₃		h		F		C	
mm	in	mm	in	mm	in	mm	in	mm	in	mm	in	mm	in	N	lbf
15	.59	7.5	.29	17	.67	7.5	.29	4.5	.18	7	.28	60	2.36	7350	1650
23	.91	11.5	.45	24	.94	11	.43	7	.28	11	.43	60	2.36	17000	7820
28	1.10	14	.55	28	1.10	14	.55	9	.35	14	.55	80	3.15	23600	5310
34	1.34	17	.67	32	1.26	14	.55	9	.35	15	.59	80	3.15	31500	7080
45	1.77	22.5	.86	42	1.65	20	.79	14	.55	21	.83	105	4.13	48000	10800
53	2.09	26.5	1.04	48	1.89	23	.91	16	.63	24	.94	120	4.72	75000	16900
63	2.48	31.5	1.24	58	2.28	26	1.02	18	.71	25	.98	150	5.91	114000	25600

mm	Load rating ¹⁾ (cont.)		Torque moment						Weight			
	C ₀		M _A		M _B		M _C		Slide unit		Rail	
	N	lbf	Nm	lbf-ft	Nm	lbf-ft	Nm	lbf-ft	kg	lb	kg/m	lb/ft
15	11600	2610	70	52	70	52	110	81	.19	.42	1.7	1.14
23	26000	5840	240	177	240	177	380	280	.54	1.19	3.7	2.49
28	35500	7980	390	288	390	288	610	450	.75	1.65	5.3	3.56
34	46500	10500	580	428	580	428	960	708	1.5	3.31	7.5	5.04
45	72000	16200	1130	833	1130	833	1960	1450	2.8	6.17	12.9	8.67
53	112200	25200	2240	1650	2240	1650	3570	2630	4.5	9.92	17.3	11.6
63	162800	36600	3780	2880	3780	2880	6290	4640	8.7	19.2	24.9	16.7

¹⁾ All MRC load ratings are based on a cumulative travel of 100.000 m in accordance with DIN 636, Part 2. The dynamic load rating must be multiplied by 1.26 for with comparison with figures based on 50.000 m cumulative travel.

LLBHS..A
 LLBHS..B
 LLBHS..R
 LLBHS..LA
 LLBHS..LB
 LLBHS..LR

All products in the heavy duty range are characterized by their especially compact and robust design without sacrificing any of the particular advantages of profile rail guides.

The use of hardened steel ensures good rigidity and insensitivity to rough treatment.

All four raceways are incorporated into the base unit. The ball return caps consist of particularly robust elements made of a tough plastic material which ensures quiet running even at high speeds.

Lubrication

Each slide unit is provided with a grease nipple on the front face. This provides simultaneous lubrication to all four ball return paths. On special order, the grease nipple can be positioned elsewhere.

Compensation for Mounting Errors

The design of the high load series enables compensation for large mounting errors without undue increase in friction.

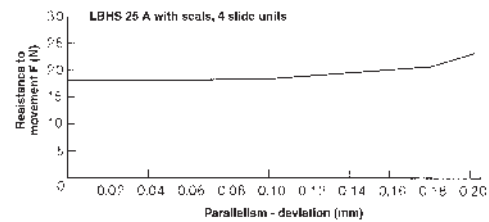
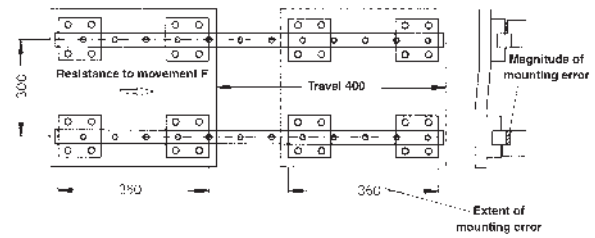

Standard Length

The rails for heavy duty profile rail guides are produced in different maximum lengths (see Table 1).

Longer lengths can be achieved by putting together separate pieces.

Rails are generally manufactured with a symmetrical hole pattern. Where this is not possible, dimension E is defined as the distance between the end of the rail and the center of the last mounting hole.

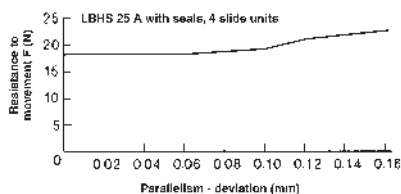
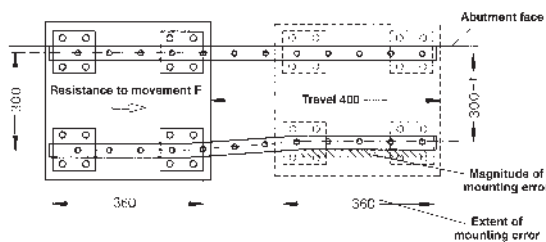

Table 1 Maximum rail length

Size	Max. length (mm)
LLBHR 15	1500
LLBHR 20	3000
LLBHR 25	3000
LLBHR 30	3000
LLBHR 35	3000
LLBHR 45	3000
LLBHR 55	3000
LLBHR 65	3000

Heavy Duty Profile Rail Guides

MRC Machine Tools

LLBHS..A
LLBHS..LA

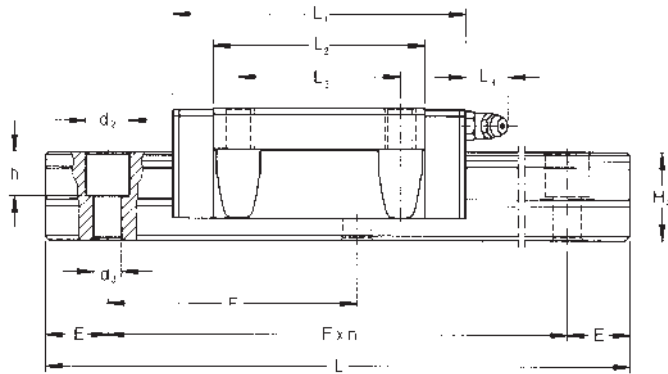
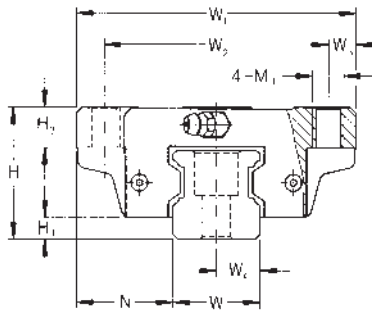

Model no.	System dimensions						Side unit					
	H		H ₁		N		W ₁		W ₂		W ₃	
	mm	in	mm	in	mm	in	mm	in	mm	in	mm	in
LLBHS 15A	24	.94	4.6	.18	16	.63	47	1.85	38	1.50	4.5	.18
LLBHS 20A	30	1.18	5	.20	21.5	.85	63	2.48	53	2.09	5	.20
LLBHS 25A	36	1.42	6.5	.26	23.5	.93	70	2.76	57	2.24	6.5	.26
LLBHS 25LA	36	1.42	6.5	.26	23.5	.93	70	2.76	57	2.24	6.5	.26
LLBHS 30A	42	1.65	7	.28	31	1.22	90	3.54	72	2.83	9	.35
LLBHS 30LA	42	1.65	7	.28	31	1.22	90	3.54	72	2.83	9	.35
LLBHS 35A	48	1.89	8	.31	33	1.30	100	3.94	82	3.23	9	.35
LLBHS 35LA	48	1.89	8	.31	33	1.30	100	3.94	82	3.23	9	.35
LLBHS 45A	60	2.36	11	.43	37.5	1.48	120	4.72	100	3.94	10	.39
LLBHS 45LA	60	2.36	11	.43	37.5	1.48	120	4.72	100	3.94	10	.39
LLBHS 55A	70	2.76	14	.55	43.5	1.71	140	5.51	116	4.57	12	.47
LLBHS 55LA	70	2.76	14	.55	43.5	1.71	140	5.51	116	4.57	12	.47
LLBHS 65A	85	3.35	14	.55	53.5	2.11	170	6.69	142	5.59	14	.55
LLBHS 65LA	85	3.35	14	.55	53.5	2.11	170	6.69	142	5.59	14	.55

Model no.	Slide unit (cont)											
	L ₁		L ₂		L ₃		L ₄		H ₃		M ₁	
	mm	in	mm	in	mm	in	mm	in	mm	in	mm	
LLBHS 15A	58.5	2.30	38.5	1.52	30	1.18			7	.28	M5 × 7	
LLBHS 20A	73	2.87	50	1.97	40	1.57			9.5	.37	M6 × 9	
LLBHS 25A	83	3.27	59	2.32	45	1.77	12	.47	10	.39	M8 × 10	
LLBHS 25LA	107	4.21	83	3.27	45	1.77	12	.47	10	.39	M8 × 10	
LLBHS 30A	97	3.82	68	2.68	52	2.05	12	.47	13	.51	M10 × 13	
LLBHS 30LA	123	4.84	94	3.70	52	2.05	12	.47	13	.51	M10 × 13	
LLBHS 35A	112	4.41	80	3.15	62	2.44	12	.47	13	.51	M10 × 13	
LLBHS 35LA	141	5.55	109	4.29	62	2.44	12	.47	13	.51	M10 × 13	
LLBHS 45A	139	5.47	102	4.02	80	3.15	14	.55	15	.59	M12 × 15	
LLBHS 45LA	167	6.57	130	5.12	80	3.15	14	.55	15	.59	M12 × 15	
LLBHS 55A	159	6.26	124	4.88	95	3.74	16	.63	17	.67	M14 × 17	
LLBHS 55LA	191	7.52	156	6.14	95	3.74	16	.63	17	.67	M14 × 17	
LLBHS 65A	188	7.40	148	5.83	110	4.33	16	.63	20	.79	M16 × 20	
LLBHS 65LA	247	9.72	207	8.15	110	4.33	16	.63	20	.79	M16 × 20	

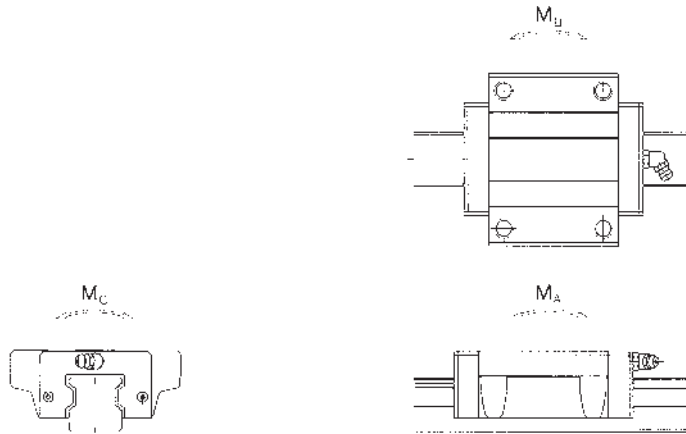

Rail													Load rating ¹⁾		
W		W ₄		H ₄		d ₂		d ₃		h		F		C	
mm	in	mm	in	mm	in	mm	in	mm	in	mm	in	mm	in	N	lbf
15	.59	7.5	.30	17	.67	7.5	.30	4.5	.18	7	.28	60	2.36	7350	1650
20	.79	10	.39	21	.83	9.5	.37	6	.24	11	.43	60	2.36	12900	2900
23	.91	11.5	.45	24	.94	11	.43	7	.28	11	.43	60	2.36	17000	3820
23	.91	11.5	.45	24	.94	11	.43	7	.28	11	.43	60	2.36	22000	4950
28	1.10	14	.55	28	1.10	14	.55	9	.35	14	.55	80	3.15	23600	5310
28	1.10	14	.55	28	1.10	14	.55	9	.35	14	.55	80	3.15	29000	6520
34	1.34	17	.67	32	1.26	14	.55	9	.35	15	.59	80	3.15	31500	7080
34	1.34	17	.67	32	1.26	14	.55	9	.35	15	.59	80	3.15	40000	8990
45	1.77	22.5	.89	42	1.65	20	.79	14	.55	21	.83	105	4.13	48000	10800
45	1.77	22.5	.89	42	1.65	20	.79	14	.55	21	.83	105	4.13	61000	13700
53	2.09	26.5	1.04	48	1.89	23	.91	16	.63	24	.94	120	4.72	75000	16900
53	2.09	26.5	1.04	48	1.89	23	.91	16	.63	24	.94	120	4.72	90000	20200
63	2.48	31.5	1.24	58	2.28	26	1.02	18	.71	25	.98	150	5.91	114000	25600
63	2.48	31.5	1.24	58	2.28	26	1.02	18	.71	25	.98	150	5.91	150000	33700

mm	Load rating ¹⁾ (cont.)		Torque moment						Weight			
	C ₀		M _A		M _B		M _C		Slide unit		Rail	
	N	lbf	Nm	lbf-ft	Nm	lbf-ft	Nm	lbf-ft	kg	lb	kg/m	lb/ft
15	11600	2610	70	52	70	52	110	81	.19	.42	1.7	1.14
20	20800	4680	190	140	190	140	260	192	.40	.88	2.8	1.88
23	26000	5840	240	177	240	177	380	280	.69	1.52	3.7	2.49
23	36000	8090	470	347	470	347	520	384	.97	2.14	3.7	2.49
28	35500	7980	390	288	390	288	610	500	1.3	2.86	5.3	3.56
28	46500	10500	660	487	660	487	800	590	1.8	5.16	5.3	3.56
34	46500	10500	580	428	580	428	960	708	1.8	5.16	7.5	5.04
34	67000	14400	1100	811	1100	811	1330	981	2.5	5.51	7.5	5.04
45	72000	16200	1130	833	1130	833	1960	1450	3.1	6.83	12.9	8.67
45	95000	21400	1920	1420	1920	1420	2570	1900	4.0	8.82	12.9	8.67
53	112200	25200	2240	1650	2240	1650	3570	2630	5.1	11.2	17.3	11.6
53	136000	30600	3300	2430	3300	2430	4330	3190	6.5	14.3	17.3	11.6
63	162800	36600	3780	2790	3780	2790	6290	4640	9.1	20.1	24.9	16.7
63	225000	50600	7240	5340	7240	5340	8690	6410	13.1	28.9	24.9	16.7

¹⁾ All MRC load ratings are based on a cumulative travel of 100.000 m in accordance with DIN 636, Part 2. The dynamic load rating must be multiplied by 1.26 for comparison with figures based on 50.000 m cumulative travel.

Heavy Duty Profile Rail Guides

MRC Machine Tools

LLBHS..B
LLBHS..LB

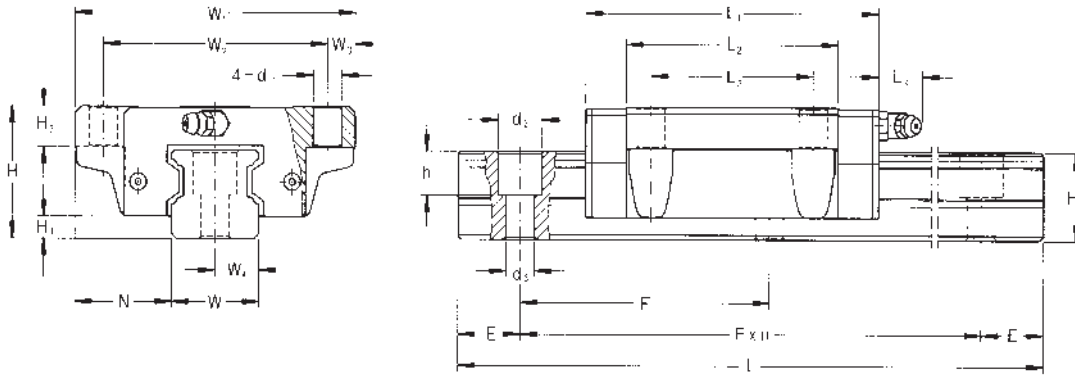

Model no.	System dimensions						Side unit					
	H		H ₁		N		W ₁		W ₂		W ₃	
	mm	in	mm	in	mm	in	mm	in	mm	in	mm	in
LLBHS 15B	24	.94	4.6	.18	16	.63	47	1.85	38	1.50	4.5	.18
LLBHS 20B	30	1.18	5	.20	21.5	.85	63	2.48	53	2.09	5	.20
LLBHS 25B	36	1.42	6.5	.26	23.5	.93	70	2.76	57	2.24	6.5	.26
LLBHS 25LB	36	1.42	6.5	.26	23.5	.93	70	2.76	57	2.24	6.5	.26
LLBHS 30B	42	1.65	7	.28	31	1.22	90	3.54	72	2.83	9	.35
LLBHS 30LB	42	1.65	7	.28	31	1.22	90	3.54	72	2.83	9	.35
LLBHS 35B	48	1.89	8	.31	33	1.30	100	3.94	82	3.23	9	.35
LLBHS 35LB	48	1.89	8	.31	33	1.30	100	3.94	82	3.23	9	.35
LLBHS 45B	60	2.36	11	.43	37.5	1.48	120	4.72	100	3.94	10	.39
LLBHS 45LB	60	2.36	11	.43	37.5	1.48	120	4.72	100	3.94	10	.39
LLBHS 55B	70	2.76	14	.55	43.5	1.71	140	5.51	116	4.57	12	.47
LLBHS 55LB	70	2.76	14	.55	43.5	1.71	140	5.51	116	4.57	12	.47
LLBHS 65B	85	3.35	14	.55	53.5	2.11	170	6.69	142	5.59	14	.55
LLBHS 65LB	85	3.35	14	.55	53.5	2.11	170	6.69	142	5.59	14	.55

Model no.	Slide unit (cont)											
	L ₁		L ₂		L ₃		L ₄		H ₃		d ₁	
	mm	in	mm	in	mm	in	mm	in	mm	in	mm	in
LLBHS 15B	58.5	2.30	38.5	1.52	30	1.18	—	—	7	.28	4.5	.18
LLBHS 20B	73	2.87	50	1.97	40	1.57	—	—	9.5	.37	6	.24
LLBHS 25B	83	3.27	59	2.32	45	1.77	12	.47	10	.39	7	.28
LLBHS 25LB	107	4.21	83	3.27	45	1.77	12	.47	10	.39	7	.28
LLBHS 30B	97	3.82	68	2.68	52	2.05	12	.47	13	.51	9	.35
LLBHS 30LB	123	4.84	94	3.70	52	2.05	12	.47	13	.51	9	.35
LLBHS 35B	112	4.41	80	3.15	62	2.44	12	.47	13	.51	9	.35
LLBHS 35LB	141	5.55	109	4.29	62	2.44	12	.47	13	.51	9	.35
LLBHS 45B	139	5.47	102	4.02	80	3.15	14	.55	15	.59	11	.43
LLBHS 45LB	167	6.57	130	5.12	80	3.15	14	.55	15	.59	11	.43
LLBHS 55B	159	6.26	124	4.88	95	3.74	16	.63	17	.67	14	.55
LLBHS 55LB	191	7.52	156	6.14	95	3.74	16	.63	17	.67	14	.55
LLBHS 65B	188	7.40	148	5.83	110	4.33	16	.63	20	.79	16	.63
LLBHS 65LB	247	9.72	207	8.15	110	4.33	16	.63	20	.79	16	.63

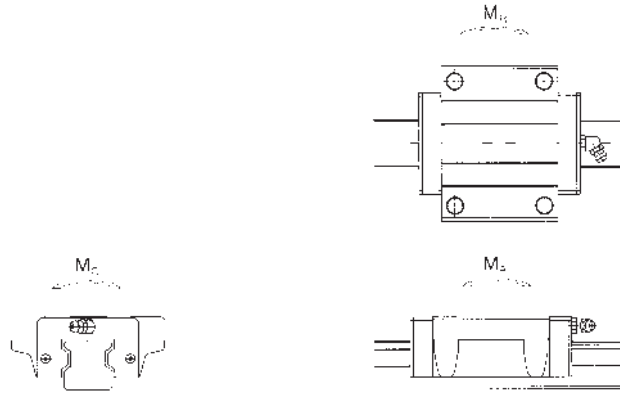

Rail													Load rating ¹⁾		
W		W ₄		H ₄		d ₂		d ₃		h		F		C	
mm	in	mm	in	mm	in	mm	in	mm	in	mm	in	mm	in	N	lbf
15	.59	7.5	.30	17	.67	7.5	.30	4.5	.18	7	.28	60	2.36	7350	1650
20	.79	10	.39	21	.83	9.5	.37	6	.24	11	.43	60	2.36	12900	2900
23	.91	11.5	.45	24	.94	11	.43	7	.28	11	.43	60	2.36	17000	3820
23	.91	11.5	.45	24	.94	11	.43	7	.28	11	.43	60	2.36	22000	4950
28	1.10	14	.55	28	1.10	14	.55	9	.35	14	.55	80	3.15	23600	5310
28	1.10	14	.55	28	1.10	14	.55	9	.35	14	.55	80	3.15	29000	6520
34	1.34	17	.67	32	1.26	14	.55	9	.35	15	.59	80	3.15	31500	7080
34	1.34	17	.67	32	1.26	14	.55	9	.35	15	.59	80	3.15	40000	8990
45	1.77	22.5	.89	42	1.65	20	.79	14	.55	21	.83	105	4.13	48000	10800
45	1.77	22.5	.89	42	1.65	20	.79	14	.55	21	.83	105	4.13	61000	13700
53	2.09	26.5	1.04	48	1.89	23	.96	16	.63	24	.94	120	4.72	75000	16900
53	2.09	26.5	1.04	48	1.89	23	.96	16	.63	24	.94	120	4.72	90000	20200
63	2.48	31.5	1.24	58	2.28	26	1.02	18	.71	25	.98	150	5.91	114000	25600
63	2.48	31.5	1.24	58	2.28	26	1.02	18	.71	25	.98	150	5.91	150000	33700

mm	Load rating ¹⁾ (cont.)		Torque moment						Weight			
	C ₀		M _A		M _B		M _C		Slide unit		Rail	
	N	lbf	Nm	lbf-ft	Nm	lbf-ft	Nm	lbf-ft	kg	lb	kg/m	lb/ft
15	11600	2610	70	52	70	52	110	81	.19	.42	1.7	1.14
20	20800	4680	190	140	190	140	260	192	.40	.88	2.8	1.88
23	26000	5840	240	177	240	177	380	280	.69	1.52	3.7	2.49
23	36000	8090	470	347	470	347	520	384	.97	2.14	3.7	2.49
28	35500	7980	390	288	390	283	610	500	1.3	2.86	5.3	3.56
28	46500	10500	660	487	660	487	800	590	1.8	5.16	5.3	3.56
34	46500	10500	580	428	580	428	960	708	1.8	5.16	7.5	5.04
34	64000	14400	1100	811	1100	811	1330	981	2.5	5.51	7.5	5.04
45	72000	16200	1130	833	1130	833	1960	1450	3.1	6.83	12.9	8.67
45	95000	21400	1920	1420	1920	1420	2570	1900	4.0	8.82	12.9	8.67
53	112200	25200	2240	1650	2240	1650	3570	2630	5.1	11.2	17.3	11.6
53	136000	30600	3300	2430	3300	2430	4330	3190	6.5	14.3	17.3	11.6
63	162800	36600	3780	2790	3780	2790	6290	4640	9.1	20.1	24.9	16.7
63	225000	50600	7240	5340	7240	5340	8690	6410	13.1	28.9	24.9	16.7

¹⁾ All MRC load ratings are based on a cumulative travel of 100.000 m in accordance with DIN 636, Part 2. The dynamic load rating must be multiplied by 1.26 for comparison with figures based on 50.000 m cumulative travel.

LLBHS..R
LLBHS..LR

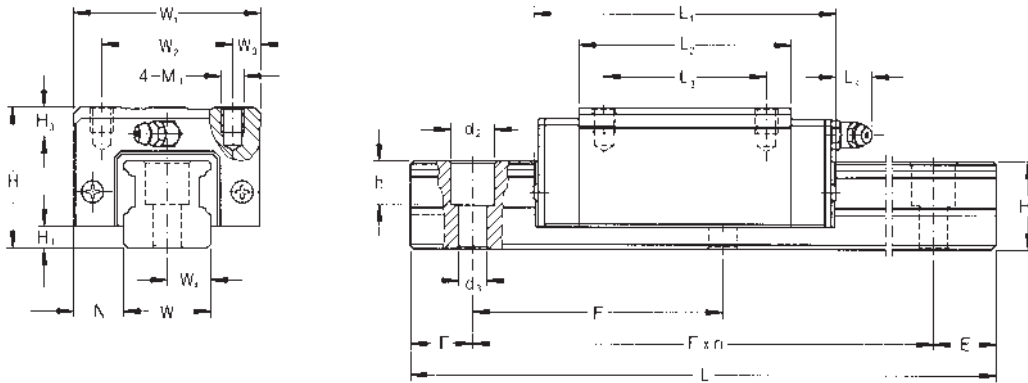

Model no.	System dimensions						Side unit					
	H		H ₁		N		W ₁		W ₂		W ₃	
	mm	in	mm	in	mm	in	mm	in	mm	in	mm	in
LLBHS 20R	30	1.18	5	.20	12	.47	44	1.73	32	1.26	6	.24
LLBHS 25R	40	1.57	6.5	.26	12.5	.49	48	1.89	35	1.38	6.5	.26
LLBHS 25LR	40	1.57	6.5	.26	12.5	.49	48	1.89	35	1.38	6.5	.26
LLBHS 30R	45	1.77	7	.28	16	.63	60	2.36	40	1.57	10	.39
LLBHS 30LR	45	1.77	7	.28	16	.63	60	2.36	40	1.57	10	.39
LLBHS 35R	55	2.17	8	.31	18	.71	70	2.76	50	1.97	10	.39
LLBHS 35LR	55	2.17	8	.31	18	.71	70	2.76	50	1.97	10	.39
LLBHS 45R	70	2.76	11	.43	20.5	.81	86	3.39	60	2.36	13	.51
LLBHS 45LR	70	2.76	11	.43	20.5	.81	86	3.39	60	2.36	13	.51
LLBHS 55R	80	3.15	14	.55	23.5	.93	100	3.94	75	2.95	12.5	.49
LLBHS 55LR	80	3.15	14	.55	23.5	.93	100	3.94	75	2.95	12.5	.49
LLBHS 65R	90	3.54	14	.55	31.5	1.24	126	4.96	90	3.54	18	.71
LLBHS 65LR	90	3.54	14	.55	31.5	1.24	126	4.96	90	3.54	18	.71

Model no.	Slide unit (cont)											
	L ₁		L ₂		L ₃		L ₄		H ₃		M ₁	
	mm	in	mm	in	mm	in	mm	in	mm	in	mm	
LLBHS 20R	73	2.87	50	1.97	36	1.42	—	—	8	.31	M5 × 8	
LLBHS 25R	83	3.27	59	2.32	35	1.38	12	.47	8	.31	M6 × 8	
LLBHS 25LR	107	4.21	83	3.27	50	1.97	12	.47	8	.31	M6 × 8	
LLBHS 30R	97	3.82	68	2.68	40	1.57	12	.47	8	.31	M8 × 10	
LLBHS 30LR	123	4.84	94	3.70	60	2.36	12	.47	8	.31	M8 × 10	
LLBHS 35R	112	4.41	80	3.15	50	1.97	12	.47	10	.39	M8 × 12	
LLBHS 35LR	141	5.55	109	4.29	72	2.83	12	.47	10	.39	M8 × 12	
LLBHS 45R	139	5.47	102	4.02	60	2.36	16	.63	15	.59	M10 × 17	
LLBHS 45LR	167	6.57	130	5.12	80	3.15	16	.63	15	.59	M10 × 17	
LLBHS 55R	168	6.61	124	4.88	75	2.95	16	.63	18	.71	M12 × 18	
LLBHS 55LR	200	7.87	156	6.14	95	3.74	16	.63	18	.71	M12 × 18	
LLBHS 65R	198	7.80	148	5.83	70	2.76	16	.63	23	.91	M16 × 20	
LLBHS 65LR	257	10.1	207	8.15	120	4.72	16	.63	23	.91	M16 × 20	

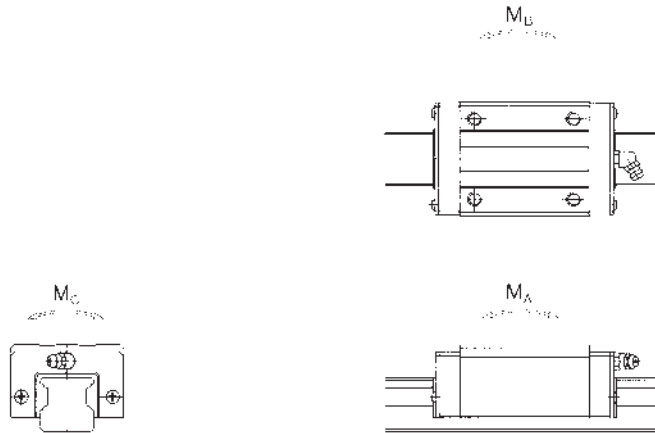

Rail												Load rating ¹⁾			
W		W ₄		H ₄		d ₂		d ₃		h		F		C	
mm	in	mm	in	mm	in	mm	in	mm	in	mm	in	mm	in	N	lbf
20	.79	10	.39	21	.75	9.5	.37	6	.24	11	.43	60	2.36	12900	2900
23	.91	11.5	.45	24	.94	11	.43	7	.28	11	.43	60	2.36	17000	3820
23	.91	11.5	.45	24	.94	11	.43	7	.28	11	.43	60	2.36	22000	4950
28	1.10	14	.55	28	1.10	14	.55	9	.35	14	.55	80	3.15	23600	5310
28	1.10	14	.55	28	1.10	14	.55	9	.35	14	.55	80	3.15	29000	6520
34	1.34	17	.67	32	1.26	14	.55	9	.35	15	.59	80	3.15	31500	7080
34	1.34	17	.67	32	1.26	14	.55	9	.35	15	.59	80	3.15	40000	8990
45	1.77	22.5	.89	42	1.65	20	.79	14	.55	21	.83	105	4.13	48000	10800
45	1.77	22.5	.89	42	1.65	20	.79	14	.55	21	.83	105	4.13	61000	13700
53	2.09	26.5	1.04	48	1.89	23	.91	16	.63	24	.94	120	4.72	75000	16900
53	2.09	26.5	1.04	48	1.89	23	.91	16	.63	24	.94	120	4.72	90000	20200
63	2.48	31.5	1.24	58	2.28	26	1.02	18	.71	25	.98	150	5.91	114000	25600
63	2.48	31.5	1.24	58	2.28	26	1.02	18	.71	25	.98	150	5.91	150000	33700

mm	Load rating ¹⁾ (cont.)		Torque moment						Weight			
	C ₀		M _A		M _B		M _C		Slide unit		Rail	
	N	lbf	Nm	lbf-ft	Nm	lbf-ft	Nm	lbf-ft	kg	lb	kg/m	lb/ft
20	20800	4680	190	140	190	140	260	192	.30	.66	2.8	1.83
23	26000	5840	240	177	240	177	380	280	.57	1.26	3.7	2.49
23	36000	8090	470	347	470	347	520	384	.80	1.76	3.7	2.49
28	35500	8010	390	288	390	288	610	500	.99	2.18	5.3	3.56
28	46500	10500	660	487	660	487	800	590	1.4	3.09	5.3	3.56
34	46500	10500	580	428	580	428	960	708	1.6	3.53	7.5	5.04
34	64000	14400	1100	811	1100	811	1330	981	2.2	4.85	7.5	5.04
45	72000	16200	1130	833	1130	833	1960	1450	2.9	6.39	12.9	8.67
45	95000	21400	1920	1420	1920	1420	2570	1900	3.7	8.16	12.9	8.67
53	112200	25200	2240	1650	2240	1650	3570	2630	4.6	9.92	17.3	11.6
53	136000	30600	3300	2430	3300	2430	4330	3190	5.8	12.8	17.3	11.6
63	162800	36600	3780	2790	3780	2790	6290	4640	7.2	15.9	24.9	16.7
63	225000	50600	7240	5340	7240	5340	8690	6410	10.5	23.1	24.9	16.7

¹⁾ All MRC load ratings are based on a cumulative travel of 100.000 m in accordance with DIN 636, Part 2. The dynamic load rating must be multiplied by 1.26 for comparison with figures based on 50.000 m cumulative travel.

LLBHB..

Where extra protection of a profile rail guide is required, MRC recommends the use of bellows, made of polyester coated on both sides with polyurethane.

- Bellows protect the guidance system against the ingress of dirt which not only increases friction but also shortens the life of the system.
- Bellows protect the operator from accidental injury.

Material

Polyester fabric coated on both sides with polyurethane.

Material thickness: 0.22 or 0.4 mm (.009 or .016 in)

Standard color: black

Recommended operating temperature: -30° to $+110^{\circ}\text{C}$
(-22° to $+230^{\circ}\text{F}$)

Resistance: Good resistance to oil and coolants

Special Designs

MRC bellows are based on a plastic frame which can be combined with various other materials. At relatively short notice, special bellows can be supplied to withstand specific extreme environmental conditions (dirt, temperature, radiation, acids, alkalis, etc.).

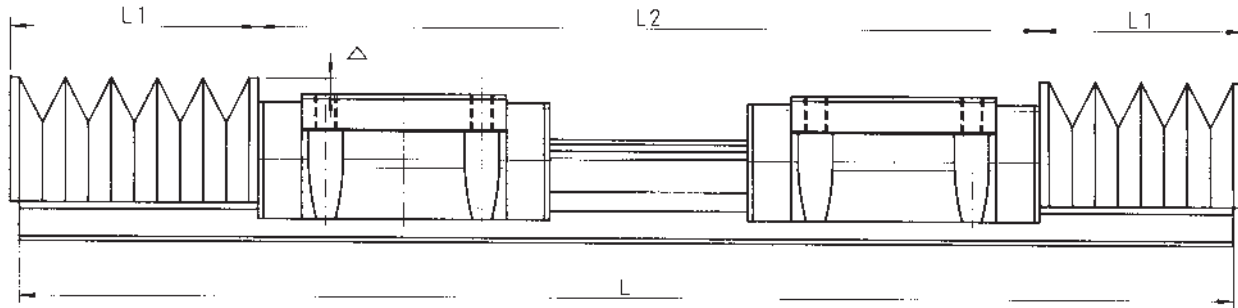

Calculation

For a given stroke and L_1 :

$$L_{\min} = \frac{S}{X - 1}$$

$$L_{\max} = S + L_{\min}$$

$$L = L_{\max} + L_{\min} + L_2$$

Number of folds:

$$n = \frac{L_{\max}}{Y} + 1$$

For given L and L_1 :

$$L_{\min} = \frac{L - L_2}{X + 1}$$

$$L_{\max} = L_{\min} \times X$$

$$S = L_{\max} - L_{\min}$$

Number of folds:

$$n = \frac{L_{\max}}{Y} + 1$$

Bellows designation	Factors						L_{\min}/fold	
	X		Y		Δ			
	mm	in	mm	in	mm	in	mm	in
LLBHB 15	9.64	.38	21.2	.83	9	.35	2.2	.09
LLBHB 20	9.64	.38	21.2	.83	7	.28	2.2	.09
LLBHB 25	6.45	.25	14.2	.56	—	—	2.2	.09
LLBHB 30	8.27	.33	18.2	.72	—	—	2.2	.09
LLBHB 35	9.64	.38	21.2	.83	—	—	2.2	.09
LLBHB 45	11.45	.45	25.2	.99	—	—	2.2	.09
LLBHB 55	11.11	.44	30	1.2	—	—	2.7	.11
LLBHB 65	11.11	.44	30	1.2	—	—	2.7	.11

LLBUS..R
 LLBUS..SR
 LLBNS..TR

To complete the range of profile rail guides MRC also offers various additional series which differ mainly in their external dimensions.

LLBUS..R and LLBUS..SR

These compact series are characterized by the optimization of the concept of profile rail guides. The assembled cross section is reduced when compared with the standard range. The LLBUS..SR range has a shorter slide unit which can be an advantage where there is no call for high load carrying capacity. On each of these series, the slide unit can only be attached from above. They are only supplied as 'end cap type' units.

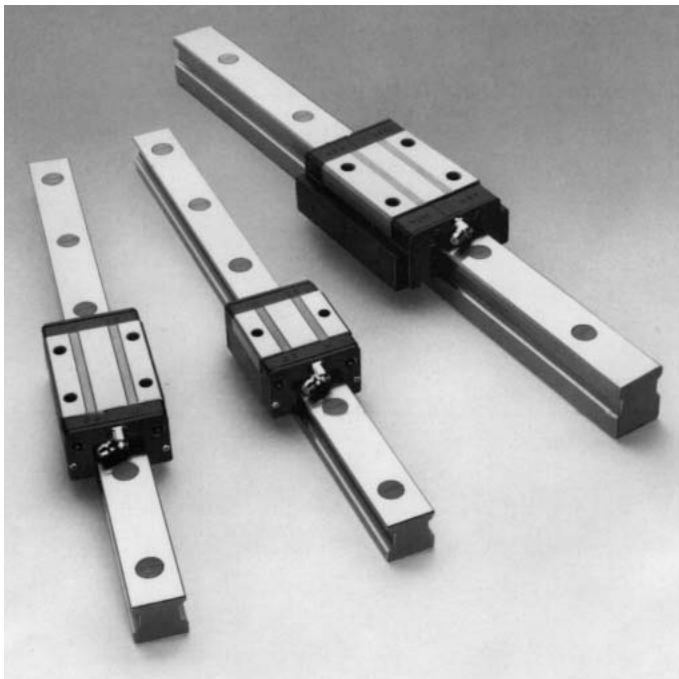

LLBNS—TR

Profile rail guides of this type have a greater height and lower load rating than the other ranges. The slide units, of the "tube type" with external ball return paths, are suitable for high speed operation and are also for attachment from above.

Standard Length

The rails for high performance profile rail guides are produced in different maximum lengths (see Table 1). Longer lengths can be achieved by putting together separate pieces. Rails are generally manufactured with a symmetrical hole pattern. Where this is not possible, dimension E is defined as the distance between the end of the rail and the center of the last mounting hole.

Size		Max. length (mm)
LLBUR 15	LLBNR 15	1500
LLBUR 20	LLBNR 20	3000
LLBUR 25	LLBNR 25	3000
LLBUR 30	LLBNR 30	3000
LLBUR 35	—	3000
—	LLBNR 40	3000
LLBUR 45	—	3000
—	LLBNR 50	3000
LLBUR 55	—	3000

Compact Profile Rail Guides

MRC Machine Tools

LLBUS..R
LLBUS..SR

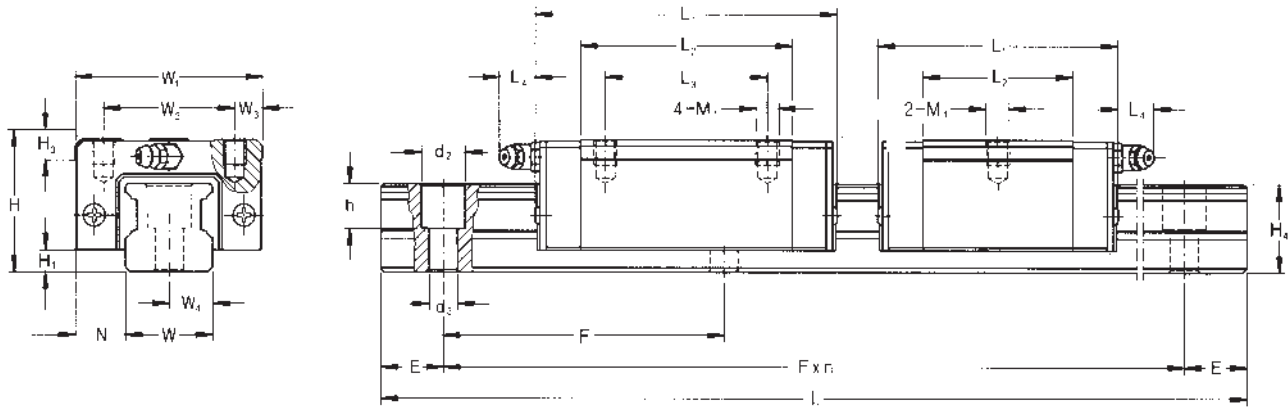

Model no.	System dimensions						Side unit					
	H		H ₁		N		W ₁		W ₂		W ₃	
	mm	in	mm	in	mm	in	mm	in	mm	in	mm	in
LLBUS 15R	24	.94	4.6	.21	9.5	.37	34	1.34	26	1.02	4	.16
LLBUS 15SR	24	.94	4.6	.21	9.5	.37	34	1.34	26	1.02	4	.16
LLBUS 20R	28	1.10	4	.16	11	.43	42	1.65	32	1.26	5	.20
LLBUS 20SR	28	1.10	4	.16	11	.43	42	1.65	32	1.26	5	.20
LLBUS 25R	33	1.30	4	.16	12.5	.49	48	1.89	35	1.38	6.5	.26
LLBUS 25SR	33	1.30	4	.16	12.5	.49	48	1.89	35	1.38	6.5	.26
LLBUS 30R	42	1.65	7	.28	16	.63	60	2.30	40	1.57	10	.39
LLBUS 30SR	42	1.65	7	.28	16	.63	60	2.36	40	1.57	10	.39
LLBUS 35R	48	1.89	8	.31	18	.71	70	2.76	50	1.97	10	.39
LLBUS 35SR	48	1.89	8	.31	18	.71	70	2.76	50	1.97	10	.39
LLBUS 45R	60	2.36	11	.43	20.5	.81	86	3.39	60	2.36	13	.51
LLBUS 55R	68	2.68	12	.47	26	1.02	100	3.94	75	2.95	12.5	.49

Model no.	Slide unit (cont)											
	L ₁		L ₂		L ₃		L ₄		H ₃		M ₁	
	mm	in	mm	in	mm	in	mm	in	mm	in	mm	
LLBUS 15R	58.5	2.30	38.5	1.52	26	1.02	0	0	6	.24	M4 × 5	
LLBUS 15SR	45	1.77	25	.98	—	—	0	0	6	.24	M4 × 5	
LLBUS 20R	72	2.83	50	1.97	32	1.26	0	0	7.5	.30	M5 × 7	
LLBUS 20SR	52	2.05	30	1.18	—	—	0	0	7.5	.30	M5 × 7	
LLBUS 25R	83	3.27	59	2.32	35	1.38	12	.47	8	.31	M6 × 8	
LLBUS 25SR	60	2.36	36	1.42	—	—	12	.47	8	.31	M6 × 8	
LLBUS 30R	97	3.82	68	2.68	40	1.57	12	.47	8	.31	M8 × 10	
LLBUS 30SR	73	2.87	44	1.73	—	—	12	.47	8	.31	M8 × 10	
LLBUS 35R	112	4.41	80	3.15	50	1.97	12	.47	10	.39	M8 × 12	
LLBUS 35SR	84	3.31	52	2.05	—	—	12	.47	10	.39	M8 × 12	
LLBUS 45R	139	5.47	102	4.02	60	2.36	14	.55	15	.59	M10 × 16	
LLBUS 55R	168	6.62	124	4.88	75	2.95	14	.55	18	.71	M12 × 18	

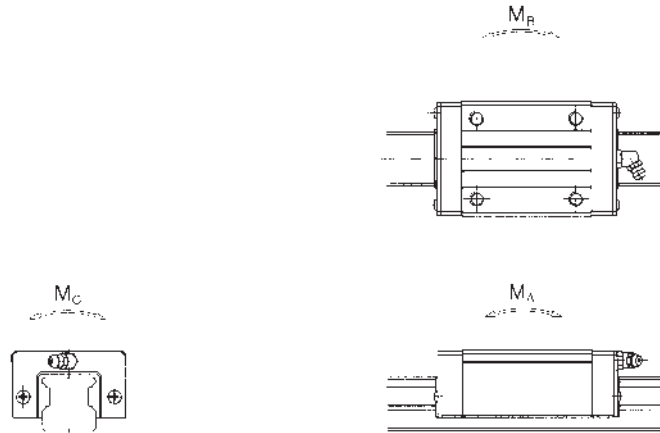

Rail												Load rating ¹⁾			
W		W ₄		H ₄		d ₂		d ₃		h		F		C	
mm	in	mm	in	mm	in	mm	in	mm	in	mm	in	mm	in	N	lbf
15	.59	7.5	.30	17	.67	6	.24	3.5	.14	9	.35	60	2.36	7350	2610
15	.59	7.5	.30	17	.67	6	.24	3.5	.14	9	.35	60	2.36	5210	1170
20	.79	10	.39	19.5	.77	9.5	.37	6	.24	12	.47	60	2.36	12900	2900
20	.79	10	.39	19.5	.77	9.5	.37	6	.24	12	.47	60	2.36	9200	2070
23	.91	11.5	.45	21.5	.85	11	.43	7	.28	12.5	.49	60	2.36	17000	3820
23	.91	11.5	.45	21.5	.85	11	.43	7	.28	12.5	.49	60	2.36	11200	2520
28	1.10	14	.35	28	1.10	11	.43	7	.28	14	.55	80	3.15	23600	5310
28	1.10	14	.55	28	1.10	11	.43	7	.28	14	.55	80	3.15	17000	3820
34	1.34	17	.67	32	1.26	14	.55	9	.35	15	.59	80	3.15	31500	7080
34	1.34	17	.67	32	1.26	14	.55	9	.35	15	.59	80	3.15	22500	5060
45	1.77	22.5	.89	42	1.65	17.5	.69	11	.43	20.5	.81	105	4.13	48000	10800
48	1.89	24	.94	46	1.81	20	.79	14	.55	25	.98	120	4.72	75000	16900

mm	Load rating ¹⁾ (cont.)		Torque moment				Weight					
	C ₀		M _A		M _B		M _C		Slide unit		Rail	
	N	lbf	Nm	lbf-ft	Nm	lbf-ft	Nm	lbf-ft	kg	lb	kg/m	lb/ft
15	11600	2610	70	52	70	52	110	81	.13	.29	1.7	1.14
15	7100	1600	30	22	30	22	60	44	.08	.18	1.7	1.14
20	20800	4680	140	103	140	103	230	170	.27	.60	2.5	1.68
20	11000	2470	50	37	50	37	140	103	.16	.35	2.5	1.68
23	26000	5840	240	177	240	177	380	280	.41	.90	3.2	2.15
23	16000	3600	90	66	90	66	230	170	.25	.55	3.2	2.15
28	35500	7980	390	287	390	287	620	457	.90	1.98	5.3	3.56
28	21500	4830	140	103	140	103	380	280	.61	1.34	5.3	3.56
34	46500	10500	580	428	580	428	960	708	1.3	2.87	7.5	5.03
34	32000	7190	280	207	280	207	670	494	.84	1.85	7.5	5.03
45	72000	16200	1130	833	1130	833	1960	1450	2.2	4.85	12.9	8.67
48	112200	25200	2240	1650	2240	1650	3570	2630	3.3	7.28	16.5	11.1

¹⁾ All MRC load ratings are based on a cumulative travel of 100.000 m in accordance with DIN 636, Part 2. The dynamic load rating must be multiplied by 1.26 for comparison with figures based on 50.000 m cumulative travel.

LLBNS..TR

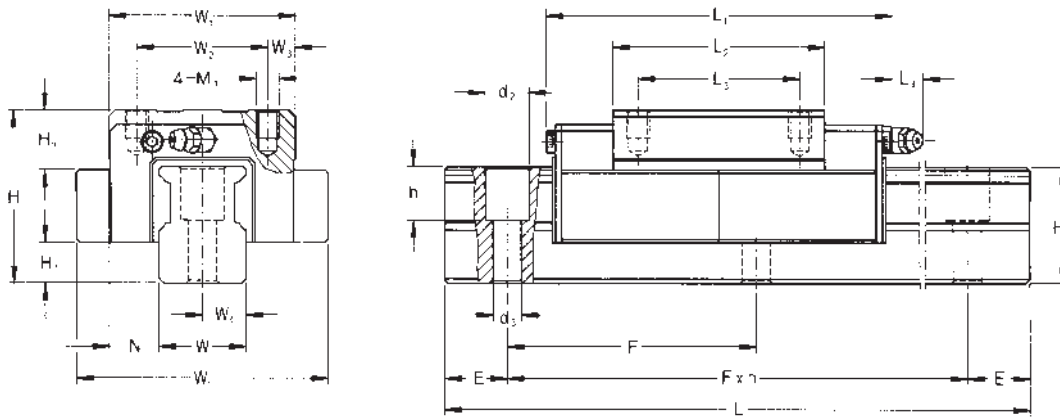

Model no.	System dimensions						Side unit					
	H		H ₁		N		W ₁		W ₂		W ₃	
	mm	in	mm	in	mm	in	mm	in	mm	in	mm	in
LLBNS 15TR	27	1.06	5	.20	9.5	.37	34	1.34	26	1.02	4	.16
LLBNS 20TR	37	1.46	8	.31	12.5	.49	48	1.89	35	1.38	6.5	.26
LLBNS 25TR	45	1.77	9.5	.37	16	.63	60	2.36	40	1.57	10	.39
LLBNS 30TR	55	2.17	13	.51	18	.71	70	2.76	50	1.97	10	.39
LLBNS 40TR	70	2.76	17	.67	20.5	.81	86	3.39	60	2.36	13	.51
LLBNS 50TR	80	3.15	13	.51	26	1.02	100	3.94	75	2.95	12.5	.49

Model no.	Slide unit (cont)												
	W ₅		L ₁		L ₂		L ₃		L ₄		H ₃		M ₁
	mm	in	mm	in	mm	in	mm	in	mm	in	mm	in	mm
LLBNS 15TR	46	1.81	65	2.56	36	1.42	26	1.02	0	0	8	.31	M4 × 5
LLBNS 20TR	62	2.44	89	3.50	54	2.13	35	1.38	3	.12	12	.47	M6 × 10
LLBNS 25TR	75	2.95	102	4.02	62	2.44	40	1.57	10	.39	12	.47	M8 × 12
LLBNS 30TR	88	3.46	116	4.37	71	2.80	50	1.97	10	.39	16	.63	M8 × 12
LLBNS 40TR	109	4.29	141	5.55	88	3.46	60	2.36	10	.39	18	.71	M10 × 14
LLBNS 50TR	127	5.00	162	6.38	97	3.82	75	2.95	10	.39	21.5	.85	M12 × 17

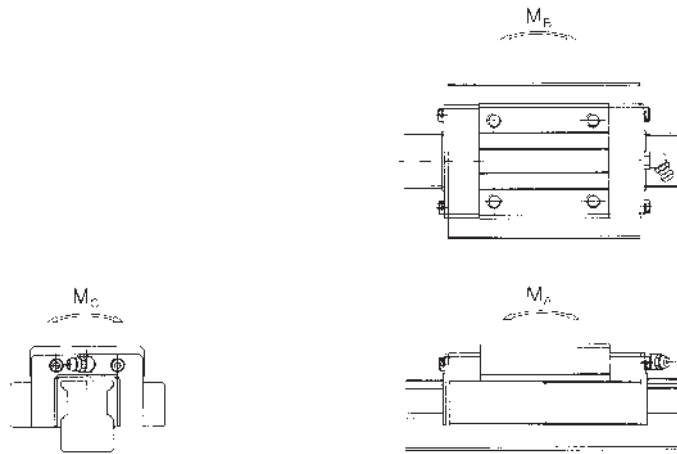

Rail												Load rating ¹⁾			
W		W ₄		H ₄		d ₂		d ₃		h		F		C	
mm	in	mm	in	mm	in	mm	in	mm	in	mm	in	mm	in	N	lbf
15	.59	7.5	.30	18	.71	6	.24	3.5	.14	9	.35	60	2.36	4520	1020
23	.91	11.5	.45	25	.98	9.5	.37	6	.24	13	.51	60	2.36	9200	2070
28	1.10	14	.55	32	1.26	11	.43	7	.28	16	.63	80	3.15	13800	3100
34	1.34	17	.67	37	1.46	11	.43	7	.28	16	.63	80	3.15	19500	4380
45	1.77	22.5	.89	48	1.84	14	.55	9	.35	23	.91	105	4.13	34400	7730
48	1.89	24	.94	49	1.93	17.5	.69	11	.43	24	.94	120	4.72	51600	11600

mm	Load rating ¹⁾ (cont.)		Torque moment						Weight			
	C ₀		M _A		M _B		M _C		Slide unit		Rail	
	N	lbf	Nm	lbf-ft	Nm	lbf-ft	Nm	lbf-ft	kg	lb	kg/m	lb/ft
15	8000	1800	50	37	50	37	70	52	.16	.35	1.9	1.28
23	16000	3600	140	103	140	103	230	170	.44	.97	4.0	2.69
28	22000	4590	220	162	220	162	380	280	.70	1.54	6.4	4.30
34	30000	6740	320	236	320	236	610	500	1.2	2.65	9.0	6.05
45	49500	11100	670	494	670	494	1340	988	2.1	4.63	15.5	10.4
48	72000	16200	1130	833	1130	833	2110	1560	3.7	8.16	16.6	11.2

¹⁾ All MRC load ratings are based on a cumulative travel of 100.000 m in accordance with DIN 636, Part 2. The dynamic load rating must be multiplied by 1.26 for with comparison with figures based on 50.000 m cumulative travel.

LLBMS..TW
LLBMS..TC

M-Type profile rail guides from MRC are basic linear guidance systems for unlimited travel, with two ball recirculation paths in the slide unit. They can be used together with either an asymmetric rail having two raceways or with H-section 4-raceway units.

These offer the following benefits:

- Low assembly profile
- Simplicity of mounting
- Equal load carrying capacity in all load directions
- Quiet running at high speed
- High load carrying capacity

Low Assembly Profile

In comparison with the other designs of rail guide M-Type profile rail guides enable the construction of particularly low-profile systems. Combinations can also be made with the 'H-type' rails (fig 2).

Simplicity of Mounting

Since the balls are safely retained in the slide carrier, mounting is fast and simple. Two alternative models are available, depending on the type of mounting.

Equal Load Carrying Capacity in All Load Directions

With two slide units mounted in parallel, the guidance system can accommodate loads from any direction.

Quiet Running at High Speed

The external ball return paths with their extra large radius of curvature provide quiet running even at high speed.

High Load Carrying Capacity

The use of steel balls of relatively large diameter provides the high stiffness and load carrying capacity of M-Type profile rail guides from MRC.

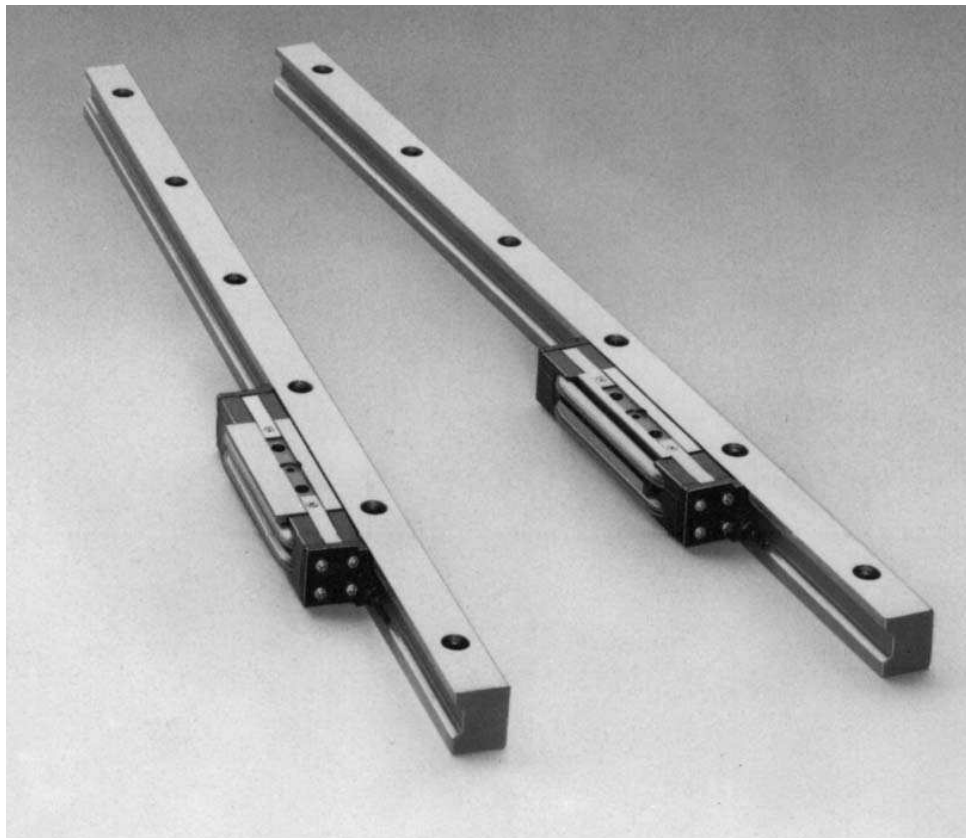

Mounting options M-TW

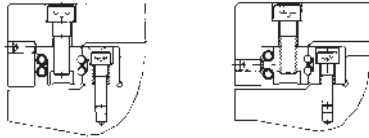

Off-center location	Central location
Light preload	High preload

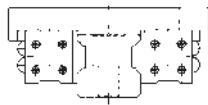

Table with H-type rail

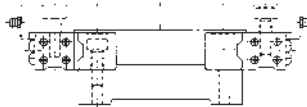

Table with M-type rail

Figure 2

Accuracy Classes

M-Type profile rail guides from MRC are available in five tolerance classes (see tables 2 and 3).

Height “H”

The tolerance of the height “H” is significant when at least two rails with slide units are to be mounted on the same base. This avoids undue misalignment of the mating surfaces.

Width “N”

The dimension “N” is of particular significance in the case of a rail with several slide units.

Standard Lengths

Rails for M-Type profile rail guides are available in various lengths (see Table 1).

Table 1 Maximum Rail Length

Size	Max. length (mm)
LLBMR 10	500
LLBMR 15	1500
LLBMR 25	1500
LLBMR 35	3000
LLBMR 40	3000
LLBMR 45	3000
LLBMR 55	3000
LLBMR 65	3000

Longer lengths can be achieved by putting together separate pieces. Special long rails can be made to order.

Preload and Stiffness

Preload is adjusted through the use of set screws on the side of the unit. By measuring the required resistance to movement of the mounted and adjusted slide unit, the preload can be calculated relatively accurately according to the following formula:

$$P = F/0.004$$

$$P = \text{Preload in Newtons (N)}$$

$$F = \text{Resistance to movement in Newtons (N)}$$

$$(\text{Pounds} = .2248\text{N})$$

Table 2 System Accuracy

Dimension		Class	P001	P01	P1	P3	P5
Height H	Dimensional tolerance	in	±.0004	±.0006	±.0008	±.0020	±.0039
		mm	±.010	±.015	±.020	±.050	±.100
	Deviation between paired rails	in	.0001	.0002	.0004	.0008	.0020
		mm	.003	.005	.010	.020	.050
Width W ₄	Dimensional tolerance	in	±.0008	±.0012	±.0020	±.0039	±.0079
		mm	±.020	±.030	±.050	±.100	±.200
	Deviation between paired rails	in	.0001	.0002	.0004	.0008	.0020
		mm	.003	.005	.010	.020	.050

Table 3 Parallelism

Rail track length (mm)		Parallelism of plane C to datum plane A						Parallelism of plane D to datum plane B					
		P001		P01		P1		P3		P5			
		mm	in	mm	in	mm	in	mm	in	mm	in		
Over	Up to												
—	315	.0015	.00006	.002	.00008	.0025	.00010	.008	.00031	.016	.00063		
315	400	.002	.00008	.0025	.00010	.0035	.00014	.010	.00039	.020	.0008		
400	500	.002	.00008	.003	.00012	.0045	.00018	.011	.00043	.024	.00095		
500	630	.002	.00008	.0035	.00014	.006	.00024	.014	.00055	.027	.0011		
630	800	.0025	.00010	.004	.00016	.008	.00031	.016	.00063	.032	.00125		
800	1000	.003	.00012	.0045	.00018	.009	.00035	.019	.00075	.038	.0015		
1000	1250	.003	.00012	.006	.00024	.011	.00043	.022	.0009	.043	.0017		
1250	1600	.004	.00016	.007	.00028	.014	.00055	.025	.0010	.050	.0020		
1600	2000	.0045	.00018	.008	.00031	.016	.00063	.029	.0011	.057	.0022		
2000	2500	.006	.00024	.009	.00035	.018	.00007	.030	.0012	.060	.0024		
2500	3150	.006	.00024	.010	.00039	.018	.00007	.030	.0012	.060	.0024		

M-Type Profile Rail Guides

MRC Machine Tools

LLBMS..TW
LLBMS..LC

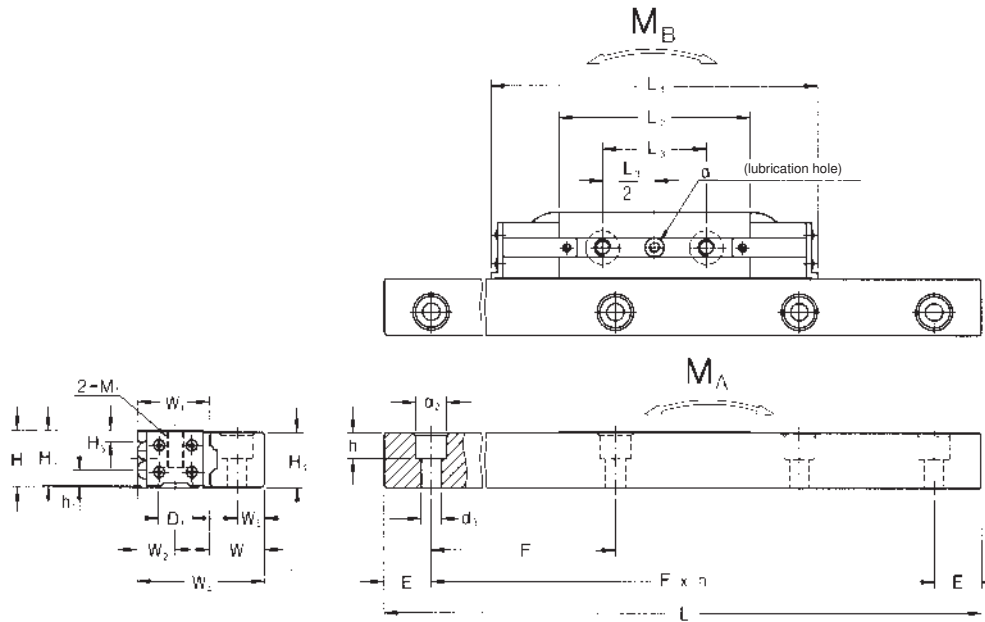

Model No.	System dimensions								Slide unit					
	H		W ₄		W ₁		W ₂		L ₁		L ₂		L ₃	
	mm	in	mm	in	mm	in	mm	in	mm	in	mm	in	mm	in
M10TW	11	.43	23	.91	11.7	.46	7	.28	69	2.72	37	1.46	15	.59
M15TW	15	.59	30	1.18	16.6	.65	10	.39	81	3.19	44	1.73	20	.79
M15TC	15	.59	30	1.18	16.6	.65	10	.39	81	3.19	44	1.73	20	.79
M25TW	20	.79	42	1.65	22.4	.88	13	.51	111	4.37	66	2.60	35	1.38
M25TC	20	.79	42	1.65	22.4	.88	13	.51	111	4.37	66	2.60	35	1.38
M35TW	25	.98	55	2.17	29.1	1.15	16	.63	141	5.55	83	3.27	45	1.77
M35TC	25	.98	55	2.17	29.1	1.15	16	.63	141	5.55	83	3.27	45	1.77
M40TW	30	1.18	65	2.56	35	1.38	19	.75	156	6.14	92	3.62	50	1.97
M40TC	30	1.18	65	2.56	35	1.38	19	.75	156	6.14	92	3.62	50	1.97
M45TW	35	1.38	75	2.95	39.9	1.57	21.5	.85	180	7.09	110	4.33	60	2.36
M45TC	35	1.38	75	2.95	39.9	1.57	21.5	.85	180	7.09	110	4.33	60	2.36
M55TW	40	1.57	85	3.35	45.6	1.80	24	.94	207	8.15	126	4.96	70	2.76
M55TC	40	1.57	85	3.35	45.6	1.80	24	.94	207	8.15	126	4.96	70	2.76
M65TW	50	1.97	105	4.13	55.3	2.18	30	1.18	240	9.45	148	5.83	85	3.35
M65TC	50	1.97	105	4.13	55.3	2.18	30	1.18	240	9.45	148	5.83	85	3.35

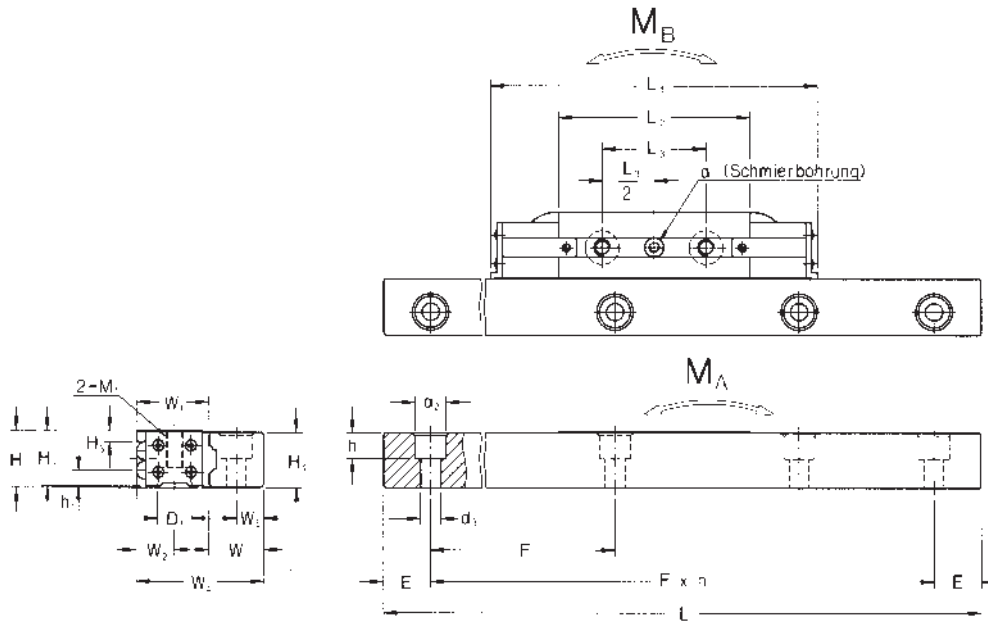

Slide unit (cont.)

Model No.	H ₂		H ₃		H ₅		D ₁		h ₁		M ₁	S		d ₁	
	mm	in	mm	in	mm	in	mm	in	mm	in	mm	mm	in	mm	in
M10TW	10.8	.43	1.8	.07	—	—	5	.20	3	.12	M3	2.55	.10	2	.08
M15TW	14.5	.57	2.2	.09	—	—	6.5	.26	3.5	.14	M4	3.3	.13	2	.08
M15TC	14.5	.57	3	.12	5.8	.23	6.5	.26	3.5	.14	M4	3.3	.13	2	.08
M25TW	19.5	.77	2.3	.09	—	—	9.5	.37	5.4	.21	M6	5.3	.21	3	.12
M25TC	19.5	.77	4	.16	7.8	.31	9.5	.37	5.4	.21	M6	5.3	.21	3	.12
M35TW	24.5	.96	2.4	.09	—	—	11	.43	6.5	.26	M8	6.8	.27	3	.12
M35TC	24.5	.96	5	.20	9.8	.39	11	.43	6.5	.26	M8	6.8	.27	3	.12
M40TW	29.5	1.16	4	.16	—	—	14	.55	8.6	.34	M10	8.6	.34	4	.16
M40TC	29.5	1.16	8	.31	10.8	.43	14	.55	8.6	.34	M10	8.6	.34	4	.16
M45TW	34.5	1.36	5.1	.20	—	—	17.5	.69	10.8	.43	M12	10.5	.41	4	.16
M45TC	34.5	1.36	9	.35	12.8	.50	17.5	.69	10.8	.43	M12	10.5	.41	4	.16
M55TW	39.5	1.56	5.8	.23	—	—	20	.79	13	.51	M14	12.5	.49	4	.16
M55TC	39.5	1.56	11	.43	14.3	.56	20	.79	13	.51	M14	12.5	.49	4	.16
M65TW	49.5	1.95	7.2	.28	—	—	23	.91	15.2	.60	M16	14.5	.57	5	.20
M65TC	49.5	1.95	15	.59	12.3	.48	23	.91	15.2	.60	M16	14.5	.57	5	.20

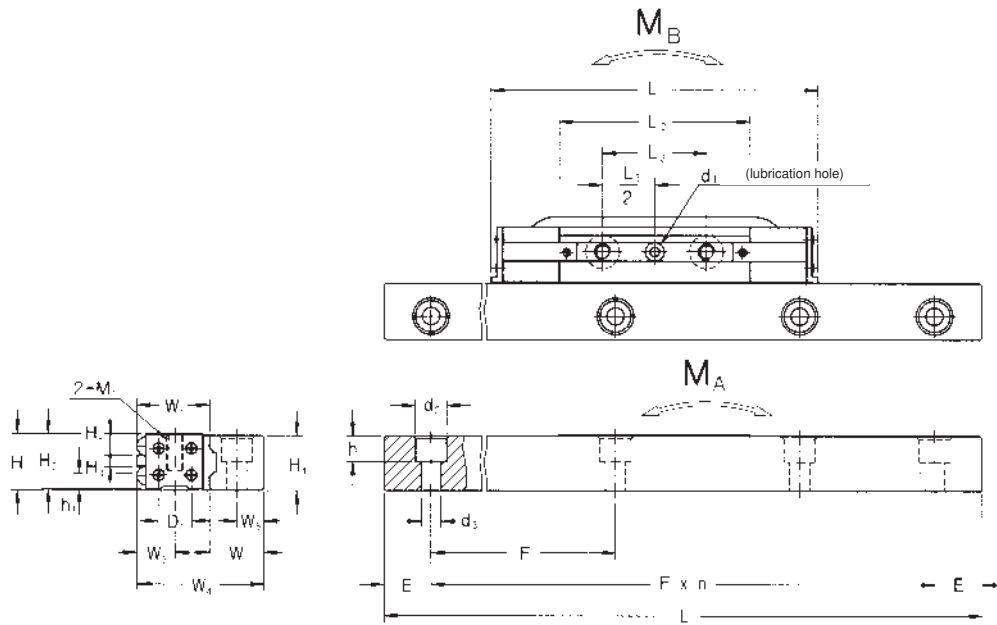

Model No.	Rail													
	W		W ₅		H ₄		d ₂		d ₃		h		F	
	mm	in	mm	in	mm	in	mm	in	mm	in	mm	in	mm	in
M10TW	11	.43	5	.20	10.8	.43	6	.24	3.4	.13	5	.20	40	1.57
M15TW	13	.51	6	.24	14.5	.57	6	.24	3.4	.13	5	.20	60	2.36
M15TC	13	.51	6	.24	14.5	.57	6	.24	3.4	.13	5	.20	60	2.36
M25TW	19	.75	8	.31	19.5	.77	9.5	.37	5.5	.22	9	.35	60	2.36
M25TC	19	.75	8	.31	19.5	.77	9.5	.37	5.5	.22	9	.35	60	2.36
M35TW	25	.98	10	.39	24.5	.96	14	.55	9	.35	12	.47	80	3.15
M35TC	25	.98	10	.39	24.5	.96	14	.55	9	.35	12	.47	80	3.15
M40TW	29	1.14	12	.47	29.5	1.16	14	.55	9	.35	12	.47	80	3.15
M40TC	29	1.14	12	.47	29.5	1.16	14	.55	9	.35	12	.47	80	3.15
M45TW	34	1.34	14.5	.57	34.5	1.36	17.5	.69	11	.43	16	.63	105	4.13
M45TC	34	1.34	14.5	.57	34.5	1.36	17.5	.69	11	.43	16	.63	105	4.13
M55TW	38	1.50	16	.63	39.5	1.56	20	.79	14	.55	19	.75	120	4.72
M55TC	38	1.50	16	.63	39.5	1.56	20	.79	14	.55	19	.75	120	4.72
M65TW	48	1.89	20	.79	49.5	1.95	26	1.02	18	.71	24	.94	150	5.91
M65TC	48	1.89	20	.79	49.5	1.95	26	1.02	18	.71	24	.94	150	5.91

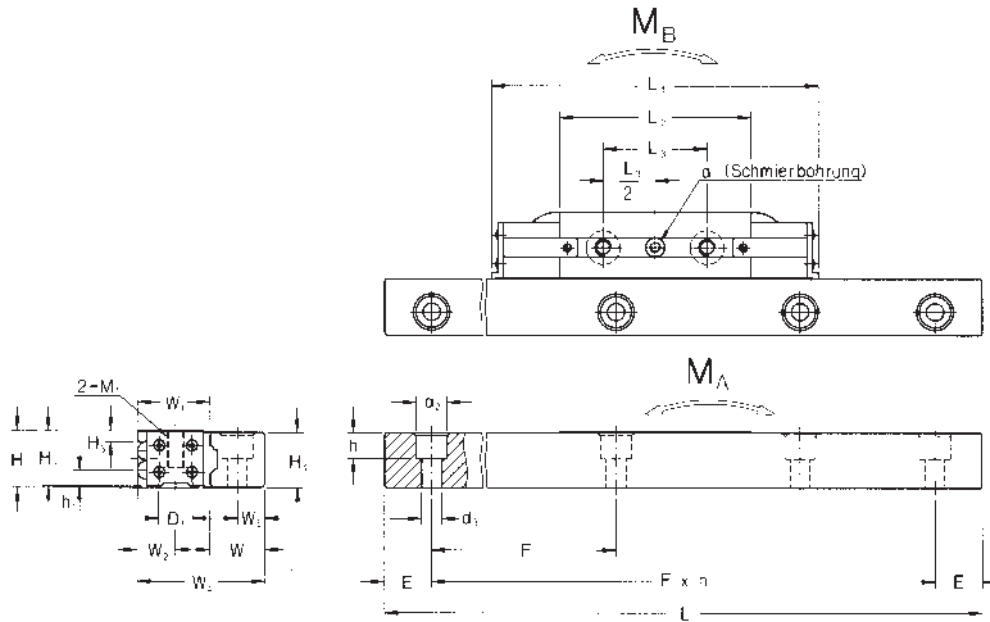

Load rating ¹⁾				Torque moment				Weight			
C		C ₀		M _A		M _B		Slide unit		Rail	
N	lbf	N	lbf	Nm	lbf-ft	Nm	lbf-ft	kg	lb	kg/m	lb/ft
2200	495	4000	899	30	22	30	22	.04	.09	.83	.56
4000	899	6600	1480	50	37	50	37	.07	.15	1.3	.87
4000	899	6600	1480	50	37	50	37	.07	.15	1.3	.87
9300	2090	14500	3260	140	103	140	103	.21	.46	2.5	1.68
9300	2090	14500	3260	140	103	140	103	.21	.46	2.5	1.68
17300	3890	24500	5510	330	243	330	243	.60	1.32	4.1	2.76
17300	3890	24500	5510	330	243	330	243	.60	1.32	4.1	2.76
20200	4540	31000	6970	430	317	430	317	.72	1.59	6.0	4.03
20200	4540	31000	6970	430	317	430	317	.72	1.59	6.0	4.03
26300	5910	41000	9220	680	502	680	502	1.1	2.43	8.2	5.51
26300	5910	41000	9220	680	502	680	502	1.1	2.43	8.2	5.51
41200	9260	55000	12400	1110	819	1110	819	1.7	3.75	10.9	7.32
41200	9260	55000	12400	1110	819	1110	819	1.7	3.75	10.9	7.32
62600	14100	82000	18400	1900	1400	1900	1400	2.9	6.39	16.4	11.0
62600	14100	82000	18400	1900	1400	1900	1400	2.9	6.39	16.4	11.0

¹⁾ All MRC load ratings are based on a cumulative travel of 100.000 m in accordance with DIN 636, Part 2. The dynamic load rating must be multiplied by 1.26 for with comparison with figures based on 50.000 m cumulative travel.

Rail Length

The maximum rail length in one piece for the different sizes is shown in the table beside. SKF is able to supply shorter rail and/or joined rails longer than the maximum length shown in the table.

Special Rail

SKF is able to deliver special rails like threaded mounting holes or additional pin holes on request. Drawing required.

Designation	Maximum length in one piece (mm)
LLMHR 7	300
LLMHR 9	500
LLMHR 12	700
LLMHR 15	900

Accuracy

Miniature Profile Rail Guides are available in two accuracy classes.

Class of accuracy	P5 (mm)	P1 (mm)
Tolerance of height "H"	± 0.020	± 0.010
Difference in height "H" between paired guides	0.015	0.007
Tolerance of width "W1"	± 0.025	± 0.015
Difference in width "W1" between paired guides	0.020	0.010

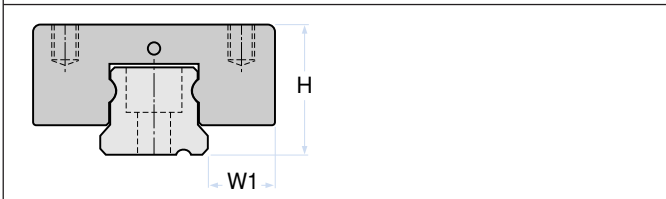

Preloading and stiffness

For trouble free operation under different and widely varying operational conditions, it is necessary to determine the appropriate preload. We recommend systems free of clearance (T0) for applications with constant load and low friction. For applications with impact loads, vibrations, different load directions or moments we recommend light preload (T1).

Designation	Zero Clearance	Light Preload T1 (µm)
LLM . C 7 TA LLM . C 7 LA	± 2	(0) - (-3)
LLM . C 9 TA LLM . C 9 LA	± 2	(0) - (-4)
LLM . C 12 TA LLM . C 12 LA	± 2	(0) - (-6)
LLM . C 15 TA LLM . C 15 LA	± 4	(0) - (-10)

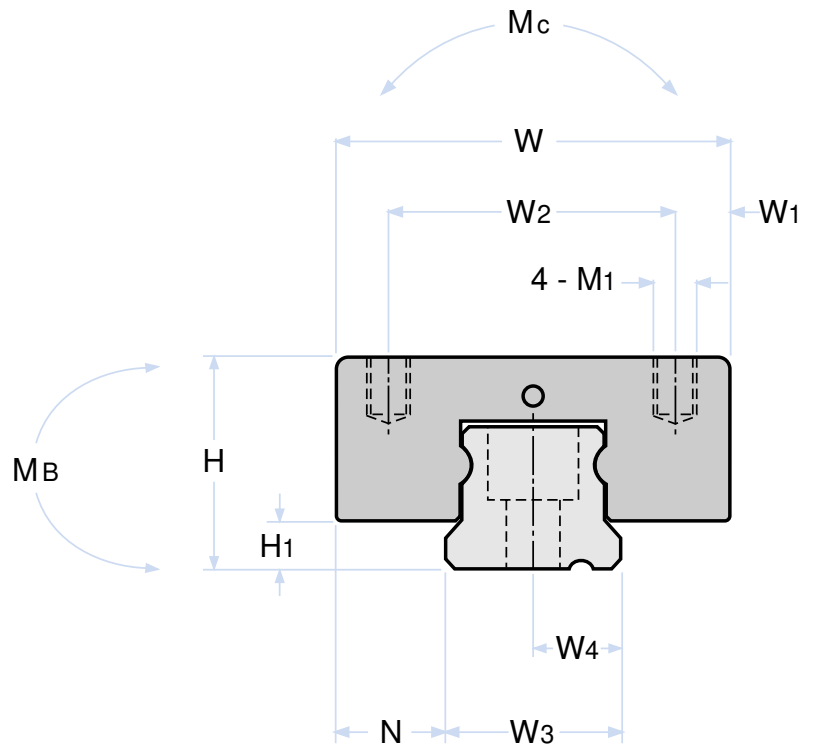

Designation	Carriage Dimensions										
	H (mm)	W (mm)	W1 (mm)	W2 (mm)	L1 (mm)	L2 (mm)	L3 (mm)	L4 (mm)	M1 (mm)	H1 (mm)	Weight (kg)
LLMHS 7 TA	8	17	2.5	12	22	16	8	23.5	M 2 x 2.5	1.5	0.01
LLMHS 9 TA	10	20	2.5	15	30	21.5	10	32	M 3 x 3	2	0.02
LLMHS 9 LA					38.5	30	15	40.5			0.03
LLMWS 9 TA	12	30	4.5	21	36.5	28	12	38.5	M 3 x 3	2	0.04
LLMWS 9 LA			3.5	23	48.5	40	24	50.5			0.06
LLMHS 12 TA	13	27	3.5	20	33	23	15	36	M 3 x 3.5	3	0.03
LLMHS 12 LA					45	35	20	48			0.06
LLMWS 12 TA	14	40	6	28	42.5	32.5	15	45.5	M 3 x 3.5	3	0.08
LLMWS 12 LA					56	46	28	59			0.11
LLMHS 15 TA	16	32	3.5	25	41.5	29.5	20	44.5	M 3 x 4	4	0.06
LLMHS 15 LA					57.5	45.4	25	60.5			0.10
LLMWS 15 TA	16	60	3.5	45	54	42	20	57	M 4 x 4.5	4.5	0.15
LLMWS 15 LA					71.5	59.5	35	74.5			0.22

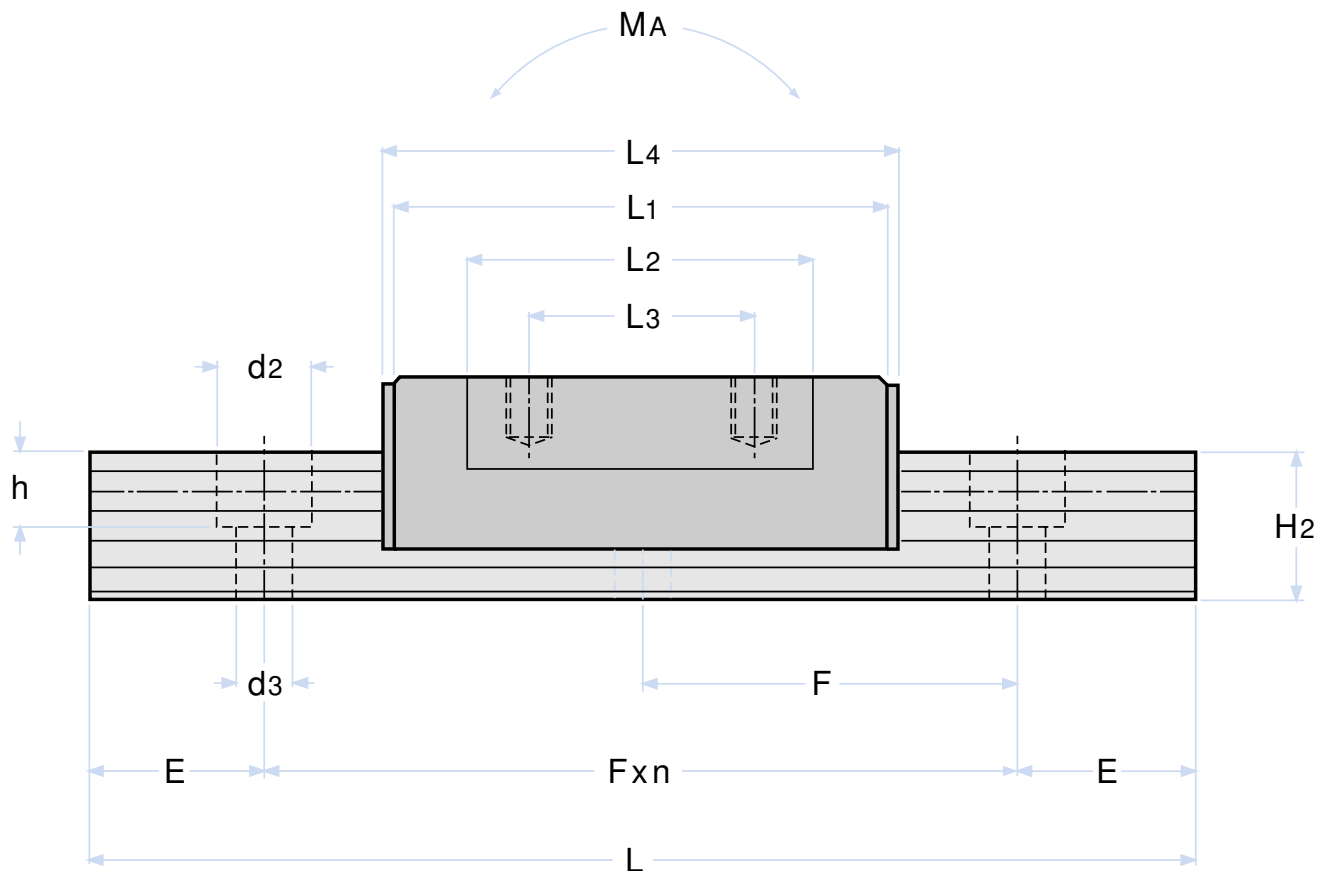

Rail Dimensions							Basic Load Rating		Static Moments		
Designation	H ₂ (mm)	W ₃ (mm)	W ₄ (mm)	d ₃ x d ₂ x h (mm)	F (mm)	Weight (kg)	C (N)	C ₀ (N)	MA (Nm)	MB (Nm)	MC (Nm)
LLMHS 7 TA	4.8	7	3.5	2.5 x 4.5 x 2.5	15	0.19	860	1 670	4.9	4.9	5.2
LLMHS 9 TA LLMHS 9 LA	6.5	9	4.5	3.5 x 6 x 3.5	20	0.31	1 850 2 295	3 130 4 270	11.2 20.1	11.2 20.1	13.2 17.9
LLMWS 9 TA LLMWS 9 LA	7.5	18	9	3.5 x 6.0 x 4.5	30	0.96	1 785 2 640	3 330 4 900	14.2 30.2	14.2 30.2	30.4 45.1
LLMHS 12 TA LLMHS 12 LA	8.8	12	6	3.5 x 6 x 4.5	25	0.62	2 550 3 470	4 000 6 225	15 34.5	15 34.5	21.7 33.8
LLMWS 12 TA LLMWS 12 LA	8.8	24	12	4.5 x 8 x 4.5	40	1.40	3 300 4 150	5 780 8 000	30 55.8	30 55.8	69 95.6
LLMHS 15 TA LLMHS 15 LA	10.8	15	7.5	3.5 x 6 x 4.5	40	1.02	2 880 4 670	5 390 8 720	21.6 57.8	25.5 68.6	40.2 67.6
LLMWS 15 TA LLMWS 15 LA	10.8	42	9.5	4.5 x 8 x 4.5	40	2.95	3 890 5 830	7 060 10 600	40.2 94.1	48.0 108	148 225

Order designation

SKF Miniature Profile Rail Guides are manufactured in a variety of types and sizes to suit particular applications. When ordering, please specify requirements in accordance with the following chart.

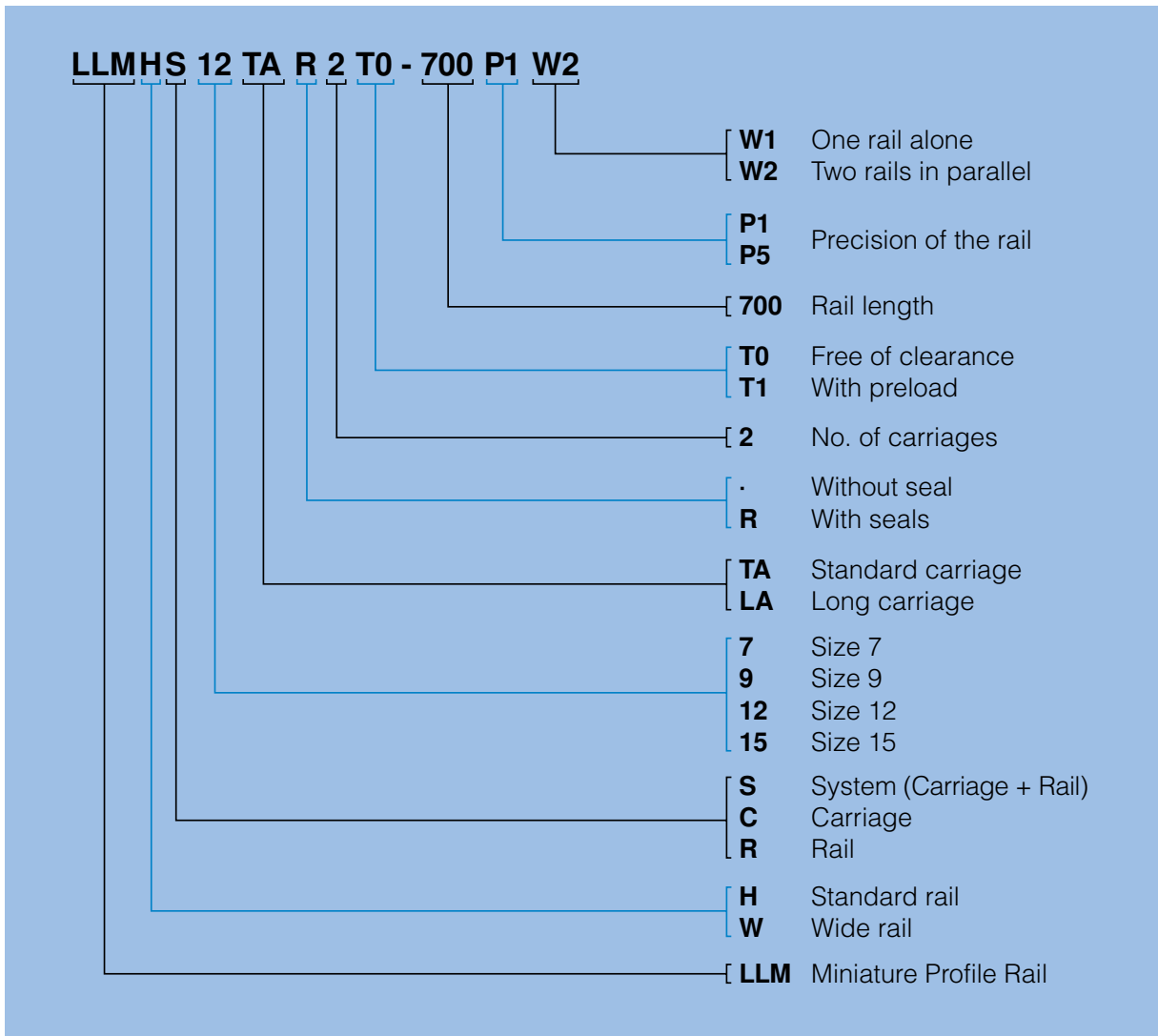

Lubrication Plate

Material: Aluminum

One set consists of

- Seal
- Screws
- Grease nipple
- Aluminum body

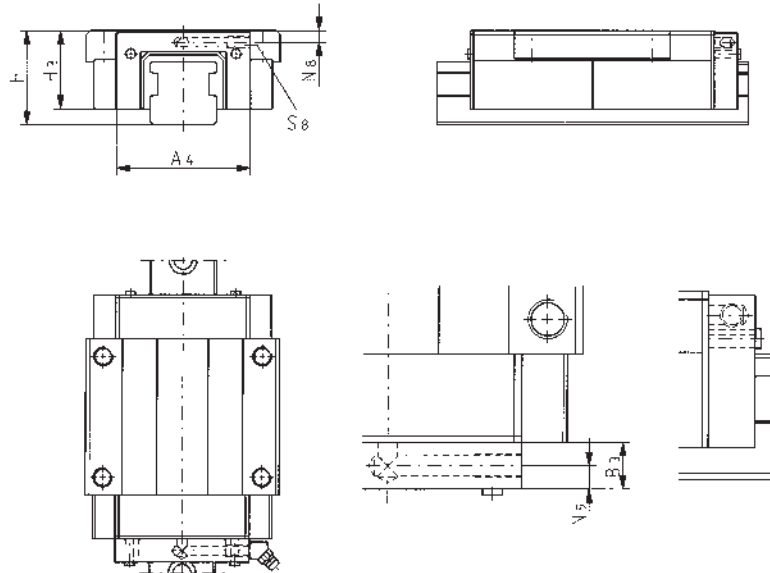

Model no.	System dimensions														Weight	
	A ₄		B ₃		H		H ₃		N ₈		N ₉		S ₈	g	oz.	
	mm	in	mm	in	mm	in	mm	in	mm	in	mm	in	mm			
LLBHA15 -G	33.5/38	1.3/1.5	12	.47	24	.94	19.4	.76	2.5/2.9	.10/.11	6	.24	3	20/25	.7/.9	
LLBHA20 -G	45	1.77	12	.47	30	1.18	25	.98	4.5	.17	6	.24	3	25	.9	
LLBHA25 -G	47/55	1.85/2.2	12	.47	36	1.42	29.5	1.16	5.5	.22	6	.24	M6	30/35	1.1/1.2	
LLBHA30 -G	59	2.32	12	.47	42	1.65	35	1.38	5	.20	6	.24	M6	45	1.6	
LLBHA35 -G	69	2.72	12	.47	48	1.89	40	1.57	6	.24	6	.24	M6	60	2.1	
LLBHA45 -G	85	3.35	12	.47	60	2.36	49	1.93	7	.28	6	.24	M6	85	3.0	
LLBHA55 -G	99	3.90	12	.47	70	2.76	56	2.20	8	.31	6	.24	M6	115	4.1	
LLBHA65 -G	125	4.92	12	.47	85	3.35	71	2.80	9	.35	6	.24	M6	250	8.8	

Designations:

LLBHA 15 .. - G

└────────── Abbreviation Carriage
(A, TA)

Notes

Product Interchange/Product Index

Section IX



This interchange is designed to provide easy conversion from competitor's numbers to the MRC equivalent. The interchange information was compiled using data available at the time of publication. MRC Bearing Services assumes no responsibility or liability for errors or omissions.

Abbreviations to Bearing Manufacturers

BAR	Barden Corp
FAF	Torrington-Ingersoll Rand (FAFNIR)
FAG	FAG Bearing Corp.
NAC	Fujikoshi Steel Industry Co. Ltd. (NACHI)
NDH	New Departure Hyatt
NSK	NSK Corp.
NTN	NTN Bearing Corp. of America
THK	THK America
THO	Thomson Industries

Precision Angular Contact Ball Bearings With 15° and 25° Contact Angles

MRC Machine Tools

MFR No.	MFR	MRC	MFR No.	MFR	MRC
B7000CTPAP4UL	FAG	100KRDS-BKE#7	B7030CTPAP4UL	FAG	130KRDS-BKE#7
B7001CTPAP4UL	FAG	101KRDS-BKE#7	B7030ETPAP4UL	FAG	7130KRDS-BKE#7
B7002CTPAP4UL	FAG	102KRDS-BKE#7	B71900CTPAP4UL	FAG	1900RDS-BKE#7
B7002ETPAP4UL	FAG	7102KRDS-BKE#7	B71901CTPAP4UL	FAG	1901RDS-BKE#7
B7003CTPAP4UL	FAG	103KRDS-BKE#7	B71902CTPAP4UL	FAG	1902RDS-BKE#7
B7003ETPAP4UL	FAG	7103KRDS-BKE#7	B71902ETPAP4UL	FAG	71902RDS-BKE#7
B7004CTPAP4UL	FAG	104KRDS-BKE#7	B71903CTPAP4UL	FAG	1903RDS-BKE#7
B7004ETPAP4UL	FAG	7104KRDS-BKE#7	B71903ETPAP4UL	FAG	71903RDS-BKE#7
B7005CTPAP4UL	FAG	105KRDS-BKE#7	B71904CTPAP4UL	FAG	1904RDS-BKE#7
B7005ETPAP4UL	FAG	7105KRDS-BKE#7	B71904ETPAP4UL	FAG	71904RDS-BKE#7
B7006CTPAP4UL	FAG	106KRDS-BKE#7	B71905CTPAP4UL	FAG	1905RDS-BKE#7
B7006ETPAP4UL	FAG	7106KRDS-BKE#7	B71905ETPAP4UL	FAG	71905RDS-BKE#7
B7007CTPAP4UL	FAG	107KRDS-BKE#7	B71906CTPAP4UL	FAG	1906RDS-BKE#7
B7007ETPAP4UL	FAG	7107KRDS-BKE#7	B71906ETPAP4UL	FAG	71906RDS-BKE#7
B7008CTPAP4UL	FAG	108KRDS-BKE#7	B71907CTPAP4UL	FAG	1907RDS-BKE#7
B7008ETPAP4UL	FAG	7108KRDS-BKE#7	B71907ETPAP4UL	FAG	71907RDS-BKE#7
B7009CTPAP4UL	FAG	109KRDS-BKE#7	B71908CTPAP4UL	FAG	1908RDS-BKE#7
B7009ETPAP4UL	FAG	7109KRDS-BKE#7	B71908ETPAP4UL	FAG	71908RDS-BKE#7
B7010CTPAP4UL	FAG	110KRDS-BKE#7	B71909CTPAP4UL	FAG	1909RDS-BKE#7
B7010ETPAP4UL	FAG	7110KRDS-BKE#7	B71909ETPAP4UL	FAG	71909RDS-BKE#7
B7011CTPAP4UL	FAG	111KRDS-BKE#7	B71910CTPAP4UL	FAG	1910RDS-BKE#7
B7011ETPAP4UL	FAG	7111KRDS-BKE#7	B71910ETPAP4UL	FAG	71910RDS-BKE#7
B7012CTPAP4UL	FAG	112KRDS-BKE#7	B71911CTPAP4UL	FAG	1911RDS-BKE#7
B7012ETPAP4UL	FAG	7112KRDS-BKE#7	B71911ETPAP4UL	FAG	71911RDS-BKE#7
B7013CTPAP4UL	FAG	113KRDS-BKE#7	B71912CTPAP4UL	FAG	1912RDS-BKE#7
B7013ETPAP4UL	FAG	7113KRDS-BKE#7	B71912ETPAP4UL	FAG	71912RDS-BKE#7
B7014CTPAP4UL	FAG	114KRDS-BKE#7	B71913CTPAP4UL	FAG	1913RDS-BKE#7
B7014ETPAP4UL	FAG	7114KRDS-BKE#7	B71913ETPAP4UL	FAG	71913RDS-BKE#7
B7015CTPAP4UL	FAG	115KRDS-BKE#7	B71914CTPAP4UL	FAG	1914RDS-BKE#7
B7015ETPAP4UL	FAG	7115KRDS-BKE#7	B71914ETPAP4UL	FAG	71914RDS-BKE#7
B7016CTPAP4UL	FAG	116KRDS-BKE#7	B71915CTPAP4UL	FAG	1915RDS-BKE#7
B7016ETPAP4UL	FAG	7116KRDS-BKE#7	B71915ETPAP4UL	FAG	71915RDS-BKE#7
B7017CTPAP4UL	FAG	117KRDS-BKE#7	B71916CTPAP4UL	FAG	1916RDS-BKE#7
B7017ETPAP4UL	FAG	7117KRDS-BKE#7	B71916ETPAP4UL	FAG	71916RDS-BKE#7
B7018CTPAP4UL	FAG	118KRDS-BKE#7	B7200CTPAP4UL	FAG	200RDS-BKE#7
B7018ETPAP4UL	FAG	7118KRDS-BKE#7	B7201CTPAP4UL	FAG	201RDS-BKE#7
B7019CTPAP4UL	FAG	119KRDS-BKE#7	B7202CTPAP4UL	FAG	202RDS-BKE#7
B7019ETPAP4UL	FAG	7119KRDS-BKE#7	B7202ETPAP4UL	FAG	7202DS-BKE#7
B7020CTPAP4UL	FAG	120KRDS-BKE#7	B7203CTPAP4UL	FAG	203RDS-BKE#7
B7020ETPAP4UL	FAG	7120KRDS-BKE#7	B7203ETPAP4UL	FAG	7203DS-BKE#7
B7022CTPAP4UL	FAG	122KRDS-BKE#7	B7204CTPAP4UL	FAG	204RDS-BKE#7
B7022ETPAP4UL	FAG	7122KRDS-BKE#7	B7204ETPAP4UL	FAG	7204DS-BKE#7
B7024CTPAP4UL	FAG	124KRDS-BKE#7	B7205CTPAP4UL	FAG	205RDS-BKE#7
B7024ETPAP4UL	FAG	7124KRDS-BKE#7	B7205ETPAP4UL	FAG	7205DS-BKE#7
B7026CTPAP4UL	FAG	126KRDS-BKE#7	B7206CTPAP4UL	FAG	206RDS-BKE#7
B7026ETPAP4UL	FAG	7126KRDS-BKE#7	B7206ETPAP4UL	FAG	7206DS-BKE#7
B7028CTPAP4UL	FAG	128KRDS-BKE#7	B7207CTPAP4UL	FAG	207RDS-BKE#7
B7028ETPAP4UL	FAG	7128KRDS-BKE#7	B7207ETPAP4UL	FAG	7207DS-BKE#7



Precision Angular Contact Ball Bearings With 15° and 25° Contact Angles

MFR No.	MFR	MRC	MFR No.	MFR	MRC
B7208CTPAP4UL	FAG	208RDS-BKE#7	QH20203DTL7A	NDH	7203DS-BKE#7
B7208ETPAP4UL	FAG	7208DS-BKE#7	QH20204DTL7A	NDH	7204DS-BKE#7
B7209CTPAP4UL	FAG	209RDS-BKE#7	QH20205DTL7A	NDH	7205DS-BKE#7
B7209ETPAP4UL	FAG	7209DS-BKE#7	QH20206DTL7A	NDH	7206DS-BKE#7
B7210CTPAP4UL	FAG	210RDS-BKE#7	QH20207DTL7A	NDH	7207DS-BKE#7
B7210ETPAP4UL	FAG	7210DS-BKE#7	QH20208DTL7A	NDH	7208DS-BKE#7
B7211CTPAP4UL	FAG	211RDS-BKE#7	QH20209DTL7A	NDH	7209DS-BKE#7
B7211ETPAP4UL	FAG	7211DS-BKE#7	QH20210DTL7A	NDH	7210DS-BKE#7
B7212CTPAP4UL	FAG	212RDS-BKE#7	QH20211DTL7A	NDH	7211DS-BKE#7
B7212ETPAP4UL	FAG	7212DS-BKE#7	QH20212DTL7A	NDH	7212DS-BKE#7
B7213CTPAP4UL	FAG	213RDS-BKE#7	QH20213DTL7A	NDH	7213DS-BKE#7
B7213ETPAP4UL	FAG	7213DS-BKE#7	QH20214DTL7A	NDH	7214DS-BKE#7
B7214CTPAP4UL	FAG	214RDS-BKE#7	Q0L00DTL7A	NDH	100KRDS-BKE#7
B7214ETPAP4UL	FAG	7214DS-BKE#7	Q0L01DTL7A	NDH	101KRDS-BKE#7
B7215CTPAP4UL	FAG	215RDS-BKE#7	Q0L02DTL7A	NDH	102KRDS-BKE#7
B7216CTPAP4UL	FAG	216RDS-BKE#7	Q0L03DTL7A	NDH	103KRDS-BKE#7
B7217CTPAP4UL	FAG	217RDS-BKE#7	Q0L04DTL7A	NDH	104KRDS-BKE#7
B7218CTPAP4UL	FAG	218RDS-BKE#7	Q0L05DTL7A	NDH	105KRDS-BKE#7
B7220CTPAP4UL	FAG	220RDS-BKE#7	Q0L06DTL7A	NDH	106KRDS-BKE#7
B7222CTPAP4UL	FAG	222RDS-BKE#7	Q0L07DTL7A	NDH	107KRDS-BKE#7
QH0L00DTL7A	NDH	7100KRDS-BKE#7	Q0L08DTL7A	NDH	108KRDS-BKE#7
QH0L01DTL7A	NDH	7101KRDS-BKE#7	Q0L09DTL7A	NDH	109KRDS-BKE#7
QH0L02DTL7A	NDH	7102KRDS-BKE#7	Q0L10DTL7A	NDH	110KRDS-BKE#7
QH0L03DTL7A	NDH	7103KRDS-BKE#7	Q0L11DTL7A	NDH	111KRDS-BKE#7
QH0L04DTL7A	NDH	7104KRDS-BKE#7	Q0L12DTL7A	NDH	112KRDS-BKE#7
QH0L05DTL7A	NDH	7105KRDS-BKE#7	Q0L13DTL7A	NDH	113KRDS-BKE#7
QH0L06DTL7A	NDH	7106KRDS-BKE#7	Q0L14DTL7A	NDH	114KRDS-BKE#7
QH0L07DTL7A	NDH	7107KRDS-BKE#7	Q0L15DTL7A	NDH	115KRDS-BKE#7
QH0L08DTL7A	NDH	7108KRDS-BKE#7	Q0L16DTL7A	NDH	116KRDS-BKE#7
QH0L09DTL7A	NDH	7109KRDS-BKE#7	Q0L17DTL7A	NDH	117KRDS-BKE#7
QH0L10DTL7A	NDH	7110KRDS-BKE#7	Q0L18DTL7A	NDH	118KRDS-BKE#7
QH0L11DTL7A	NDH	7111KRDS-BKE#7	Q0L20DTL7A	NDH	120KRDS-BKE#7
QH0L12DTL7A	NDH	7112KRDS-BKE#7	Q0L21DTL7A	NDH	121KRDS-BKE#7
QH0L13DTL7A	NDH	7113KRDS-BKE#7	Q0L22DTL7A	NDH	122KRDS-BKE#7
QH0L14DTL7A	NDH	7114KRDS-BKE#7	Q0L24DTL7A	NDH	124KRDS-BKE#7
QH0L15DTL7A	NDH	7115KRDS-BKE#7	Q0L26DTL7A	NDH	126KRDS-BKE#7
QH0L16DTL7A	NDH	7116KRDS-BKE#7	Q0L28DTL7A	NDH	128KRDS-BKE#7
QH0L17DTL7A	NDH	7117KRDS-BKE#7	Q0L30DTL7A	NDH	130KRDS-BKE#7
QH0L18DTL7A	NDH	7118KRDS-BKE#7	Q20200DTL7A	NDH	200RDS-BKE#7
QH0L20DTL7A	NDH	7120KRDS-BKE#7	Q20201DTL7A	NDH	201RDS-BKE#7
QH0L22DTL7A	NDH	7122KRDS-BKE#7	Q20202DTL7A	NDH	202RDS-BKE#7
QH0L24DTL7A	NDH	7124KRDS-BKE#7	Q20203DTL7A	NDH	203RDS-BKE#7
QH0L26DTL7A	NDH	7126KRDS-BKE#7	Q20204DTL7A	NDH	204RDS-BKE#7
QH0L28DTL7A	NDH	7128KRDS-BKE#7	Q20205DTL7A	NDH	205RDS-BKE#7
QH0L30DTL7A	NDH	7130KRDS-BKE#7	Q20206DTL7A	NDH	206RDS-BKE#7
QH20200DTL7A	NDH	7200DS-BKE#7	Q20207DTL7A	NDH	207RDS-BKE#7
QH20201DTL7A	NDH	7201DS-BKE#7	Q20208DTL7A	NDH	208RDS-BKE#7
QH20202DTL7A	NDH	7202DS-BKE#7	Q20209DTL7A	NDH	209RDS-BKE#7

Precision Angular Contact Ball Bearings

MRC Machine Tools

MFR No.	MFR	MRC	MFR No.	MFR	MRC
Q20210DTL7A	NDH	210RDS-BKE#7	124HDL	BAR	124KRDS-BKE#7
Q20211DTL7A	NDH	211RDS-BKE#7	126HDL	BAR	126KRDS-BKE#7
Q20212DTL7A	NDH	212RDS-BKE#7	2MM200WIDUL	FAF	200RDS-BKE#7
Q20213DTL7A	NDH	213RDS-BKE#7	2MM201WIDUL	FAF	201RDS-BKE#7
Q20214DTL7A	NDH	214RDS-BKE#7	2MM202WIDUL	FAF	202RDS-BKE#7
Q20215DTL7A	NDH	215RDS-BKE#7	2MM203WIDUL	FAF	203RDS-BKE#7
Q20216DTL7A	NDH	216RDS-BKE#7	2MM204WIDUL	FAF	204RDS-BKE#7
Q20217DTL7A	NDH	217RDS-BKE#7	2MM205WIDUL	FAF	205RDS-BKE#7
Q20218DTL7A	NDH	218RDS-BKE#7	2MM206WIDUL	FAF	206RDS-BKE#7
Q20219DTL7A	NDH	219RDS-BKE#7	2MM207WIDUL	FAF	207RDS-BKE#7
Q20220DTL7A	NDH	220RDS-BKE#7	2MM208WIDUL	FAF	208RDS-BKE#7
Q20222DTL7A	NDH	222RDS-BKE#7	2MM209WIDUL	FAF	209RDS-BKE#7
Q20224DTL7A	NDH	224RDS-BKE#7	2MM210WIDUL	FAF	210RDS-BKE#7
Q20300DTL7A	NDH	300RDS-BKE#7	2MM211WIDUL	FAF	211RDS-BKE#7
Q20301DTL7A	NDH	301RDS-BKE#7	2MM212WIDUL	FAF	212RDS-BKE#7
Q20302DTL7A	NDH	302RDS-BKE#7	2MM213WIDUL	FAF	213RDS-BKE#7
Q20303DTL7A	NDH	303RDS-BKE#7	2MM214WIDUL	FAF	214RDS-BKE#7
Q20304DTL7A	NDH	304RDS-BKE#7	2MM215WIDUL	FAF	215RDS-BKE#7
Q20305DTL7A	NDH	305RDS-BKE#7	2MM216WIDUL	FAF	216RDS-BKE#7
Q20306DTL7A	NDH	306RDS-BKE#7	2MM217WIDUL	FAF	217RDS-BKE#7
Q20307DTL7A	NDH	307RDS-BKE#7	2MM218WIDUL	FAF	218RDS-BKE#7
Q20308DTL7A	NDH	308RDS-BKE#7	2MM219WIDUL	FAF	219RDS-BKE#7
Q20309DTL7A	NDH	309RDS-BKE#7	2MM220WIDUL	FAF	220RDS-BKE#7
Q20310DTL7A	NDH	310RDS-BKE#7	2MM222WIDUL	FAF	222RDS-BKE#7
Q20311DTL7A	NDH	311RDS-BKE#7	2MM224WIDUL	FAF	224RDS-BKE#7
Q20312DTL7A	NDH	312RDS-BKE#7	2MM300WIDUL	FAF	300RDS-BKE#7
100HDL	BAR	100KRDS-BKE#7	2MM301WIDUL	FAF	301RDS-BKE#7
101HDL	BAR	101KRDS-BKE#7	2MM302WIDUL	FAF	302RDS-BKE#7
102HDL	BAR	102KRDS-BKE#7	2MM303WIDUL	FAF	303RDS-BKE#7
103HDL	BAR	103KRDS-BKE#7	2MM304WIDUL	FAF	304RDS-BKE#7
104HDL	BAR	104KRDS-BKE#7	2MM305WIDUL	FAF	305RDS-BKE#7
105HDL	BAR	105KRDS-BKE#7	2MM306WIDUL	FAF	306RDS-BKE#7
106HDL	BAR	106KRDS-BKE#7	2MM307WIDUL	FAF	307RDS-BKE#7
107HDL	BAR	107KRDS-BKE#7	2MM308WIDUL	FAF	308RDS-BKE#7
108HDL	BAR	108KRDS-BKE#7	2MM309WIDUL	FAF	309RDS-BKE#7
109HDL	BAR	109KRDS-BKE#7	2MM310WIDUL	FAF	310RDS-BKE#7
110HDL	BAR	110KRDS-BKE#7	2MM311WIDUL	FAF	311RDS-BKE#7
111HDL	BAR	111KRDS-BKE#7	2MM312WIDUL	FAF	312RDS-BKE#7
112HDL	BAR	112KRDS-BKE#7	2MM9100WIDUL	FAF	100KRDS-BKE#7
113HDL	BAR	113KRDS-BKE#7	2MM9101WIDUL	FAF	101KRDS-BKE#7
114HDL	BAR	114KRDS-BKE#7	2MM9102WIDUL	FAF	102KRDS-BKE#7
115HDL	BAR	115KRDS-BKE#7	2MM9103WIDUL	FAF	103KRDS-BKE#7
116HDL	BAR	116KRDS-BKE#7	2MM9104WIDUL	FAF	104KRDS-BKE#7
117HDL	BAR	117KRDS-BKE#7	2MM9105WIDUL	FAF	105KRDS-BKE#7
118HDL	BAR	118KRDS-BKE#7	2MM9106WIDUL	FAF	106KRDS-BKE#7
120HDL	BAR	120KRDS-BKE#7	2MM9107WIDUL	FAF	107KRDS-BKE#7
121HDL	BAR	121KRDS-BKE#7	2MM9108WIDUL	FAF	108KRDS-BKE#7
122HDL	BAR	122KRDS-BKE#7	2MM9109WIDUL	FAF	109KRDS-BKE#7



Precision Angular Contact Ball Bearings With 15° and 25° Contact Angles

MFR No.	MFR	MRC	MFR No.	MFR	MRC
2MM9110WIDUL	FAF	110KRDS-BKE#7	202HDL	BAR	202RDS-BKE#7
2MM9111WIDUL	FAF	111KRDS-BKE#7	203HDL	BAR	203RDS-BKE#7
2MM9112WIDUL	FAF	112KRDS-BKE#7	204HDL	BAR	204RDS-BKE#7
2MM9113WIDUL	FAF	113KRDS-BKE#7	205HDL	BAR	205RDS-BKE#7
2MM9114WIDUL	FAF	114KRDS-BKE#7	206HDL	BAR	206RDS-BKE#7
2MM9115WIDUL	FAF	115KRDS-BKE#7	207HDL	BAR	207RDS-BKE#7
2MM9116WIDUL	FAF	116KRDS-BKE#7	208HDL	BAR	208RDS-BKE#7
2MM9117WIDUL	FAF	117KRDS-BKE#7	209HDL	BAR	209RDS-BKE#7
2MM9118WIDUL	FAF	118KRDS-BKE#7	210HDL	BAR	210RDS-BKE#7
2MM9120WIDUL	FAF	120KRDS-BKE#7	2100HDL	BAR	7100KRDS-BKE#7
2MM9121WIDUL	FAF	121KRDS-BKE#7	2101HDL	BAR	7101KRDS-BKE#7
2MM9122WIDUL	FAF	122KRDS-BKE#7	2102HDL	BAR	7102KRDS-BKE#7
2MM9124WIDUL	FAF	124KRDS-BKE#7	2103HDL	BAR	7103KRDS-BKE#7
2MM9126WIDUL	FAF	126KRDS-BKE#7	2104HDL	BAR	7104KRDS-BKE#7
2MM9128WIDUL	FAF	128KRDS-BKE#7	2105HDL	BAR	7105KRDS-BKE#7
2MM9130WIDUL	FAF	130KRDS-BKE#7	2106HDL	BAR	7106KRDS-BKE#7
2MM9132WIDUL	FAF	132KRDS-BKE#7	2107HDL	BAR	7107KRDS-BKE#7
2MM9134WIDUL	FAF	134KRDS-BKE#7	2108HDL	BAR	7108KRDS-BKE#7
2MM9140WIDUL	FAF	140KRDS-BKE#7	2109HDL	BAR	7109KRDS-BKE#7
2MM9300WIDUL	FAF	1900RDS-BKE#7	211HDL	BAR	211RDS-BKE#7
2MM9301WIDUL	FAF	1901RDS-BKE#7	2110HDL	BAR	7110KRDS-BKE#7
2MM9302WIDUL	FAF	1902RDS-BKE#7	2111HDL	BAR	7111KRDS-BKE#7
2MM9303WIDUL	FAF	1903RDS-BKE#7	2112HDL	BAR	7112KRDS-BKE#7
2MM9304WIDUL	FAF	1904RDS-BKE#7	2113HDL	BAR	7113KRDS-BKE#7
2MM9305WIDUL	FAF	1905RDS-BKE#7	2114HDL	BAR	7114KRDS-BKE#7
2MM9306WIDUL	FAF	1906RDS-BKE#7	2115HDL	BAR	7115KRDS-BKE#7
2MM9307WIDUL	FAF	1907RDS-BKE#7	2116HDL	BAR	7116KRDS-BKE#7
2MM9308WIDUL	FAF	1908RDS-BKE#7	2117HDL	BAR	7117KRDS-BKE#7
2MM9309WIDUL	FAF	1909RDS-BKE#7	2118HDL	BAR	7118KRDS-BKE#7
2MM9310WIDUL	FAF	1910RDS-BKE#7	212HDL	BAR	212RDS-BKE#7
2MM9311WIDUL	FAF	1911RDS-BKE#7	2120HDL	BAR	7120KRDS-BKE#7
2MM9312WIDUL	FAF	1912RDS-BKE#7	2122HDL	BAR	7122KRDS-BKE#7
2MM9313WIDUL	FAF	1913RDS-BKE#7	2124HDL	BAR	7124KRDS-BKE#7
2MM9314WIDUL	FAF	1914RDS-BKE#7	2126HDL	BAR	7126KRDS-BKE#7
2MM9315WIDUL	FAF	1915RDS-BKE#7	2128HDL	BAR	7128KRDS-BKE#7
2MM9316WIDUL	FAF	1916RDS-BKE#7	213HDL	BAR	213RDS-BKE#7
2MM9317WIDUL	FAF	1917RDS-BKE#7	214HDL	BAR	214RDS-BKE#7
2MM9318WIDUL	FAF	1918RDS-BKE#7	215HDL	BAR	215RDS-BKE#7
2MM9319WIDUL	FAF	1919RDS-BKE#7	216HDL	BAR	216RDS-BKE#7
2MM9320WIDUL	FAF	1920RDS-BKE#7	217HDL	BAR	217RDS-BKE#7
2MM9321WIDUL	FAF	1921RDS-BKE#7	218HDL	BAR	218RDS-BKE#7
2MM9322WIDUL	FAF	1922RDS-BKE#7	219HDL	BAR	219RDS-BKE#7
2MM9324WIDUL	FAF	1924RDS-BKE#7	220HDL	BAR	220RDS-BKE#7
2MM9326WIDUL	FAF	1926RDS-BKE#7	2202HDL	BAR	7202DS-BKE#7
2MM9328WIDUL	FAF	1928RDS-BKE#7	2203HDL	BAR	7203DS-BKE#7
2MM9330WIDUL	FAF	1930RDS-BKE#7	2204HDL	BAR	7204DS-BKE#7
200HDL	BAR	200RDS-BKE#7	2205HDL	BAR	7205DS-BKE#7
201HDL	BAR	201RDS-BKE#7	2206HDL	BAR	7206DS-BKE#7

Precision Angular Contact Ball Bearings With 15° and 25° Contact Angles

MRC Machine Tools

MFR No.	MFR	MRC	MFR No.	MFR	MRC
2207HDL	BAR	7207DS-BKE#7	304HDL	BAR	304RDS-BKE#7
2208HDL	BAR	7208DS-BKE#7	305HDL	BAR	305RDS-BKE#7
2209HDL	BAR	7209DS-BKE#7	306HDL	BAR	306RDS-BKE#7
2210HDL	BAR	7210DS-BKE#7	307HDL	BAR	307RDS-BKE#7
2211HDL	BAR	7211DS-BKE#7	308HDL	BAR	308RDS-BKE#7
2212HDL	BAR	7212DS-BKE#7	309HDL	BAR	309RDS-BKE#7
2213HDL	BAR	7213DS-BKE#7	310HDL	BAR	310RDS-BKE#7
2214HDL	BAR	7214DS-BKE#7	7000ACDP4ADGA	SKF	7100KRDS-BKE#7
222HDL	BAR	222RDS-BKE#7	7000A5TDULP4	NSK	7100KRDS-BKE#7
224HDL	BAR	224RDS-BKE#7	7000CDP4ADGA	SKF	100KRDS-BKE#7
3MM202WIDUL	FAF	7202DS-BKE#7	7000CTDULP4	NSK	100KRDS-BKE#7
3MM203WIDUL	FAF	7203DS-BKE#7	7001ACDP4ADGA	SKF	7101KRDS-BKE#7
3MM204WIDUL	FAF	7204DS-BKE#7	7001A5TDULP4	NSK	7101KRDS-BKE#7
3MM205WIDUL	FAF	7205DS-BKE#7	7001CDP4ADGA	SKF	101KRDS-BKE#7
3MM206WIDUL	FAF	7206DS-BKE#7	7001CTDULP4	NSK	101KRDS-BKE#7
3MM207WIDUL	FAF	7207DS-BKE#7	7002ACDP4ADGA	SKF	7102KRDS-BKE#7
3MM208WIDUL	FAF	7208DS-BKE#7	7002A5TDULP4	NSK	7102KRDS-BKE#7
3MM209WIDUL	FAF	7209DS-BKE#7	7002CDP4ADGA	SKF	102KRDS-BKE#7
3MM210WIDUL	FAF	7210DS-BKE#7	7002CTDULP4	NSK	102KRDS-BKE#7
3MM211WIDUL	FAF	7211DS-BKE#7	7003ACDP4ADGA	SKF	7103KRDS-BKE#7
3MM212WIDUL	FAF	7212DS-BKE#7	7003A5TDULP4	NSK	7103KRDS-BKE#7
3MM213WIDUL	FAF	7213DS-BKE#7	7003CDP4ADGA	SKF	103KRDS-BKE#7
3MM214WIDUL	FAF	7214DS-BKE#7	7003CTDULP4	NSK	103KRDS-BKE#7
3MM9100WIDUL	FAF	7100KRDS-BKE#7	7004ACDP4ADGA	SKF	7104KRDS-BKE#7
3MM9101WIDUL	FAF	7101KRDS-BKE#7	7004A5TDULP4	NSK	7104KRDS-BKE#7
3MM9102WIDUL	FAF	7102KRDS-BKE#7	7004CDP4ADGA	SKF	104KRDS-BKE#7
3MM9103WIDUL	FAF	7103KRDS-BKE#7	7004CTDULP4	NSK	104KRDS-BKE#7
3MM9104WIDUL	FAF	7104KRDS-BKE#7	7005ACDP4ADGA	SKF	7105KRDS-BKE#7
3MM9105WIDUL	FAF	7105KRDS-BKE#7	7005A5TDULP4	NSK	7105KRDS-BKE#7
3MM9106WIDUL	FAF	7106KRDS-BKE#7	7005CDP4ADGA	SKF	105KRDS-BKE#7
3MM9107WIDUL	FAF	7107KRDS-BKE#7	7005CTDULP4	NSK	105KRDS-BKE#7
3MM9108WIDUL	FAF	7108KRDS-BKE#7	7006ACDP4ADGA	SKF	7106KRDS-BKE#7
3MM9109WIDUL	FAF	7109KRDS-BKE#7	7006A5TDULPA	NSK	7106KRDS-BKE#7
3MM9110WIDUL	FAF	7110KRDS-BKE#7	7006CDP4ADGA	SKF	106KRDS-BKE#7
3MM9111WIDUL	FAF	7111KRDS-BKE#7	7006CTDULP4	NSK	106KRDS-BKE#7
3MM9112WIDUL	FAF	7112KRDS-BKE#7	7007ACDP4ADGA	SKF	7107KRDS-BKE#7
3MM9113WIDUL	FAF	7113KRDS-BKE#7	7007A5TDULP4	NSK	7107KRDS-BKE#7
3MM9114WIDUL	FAF	7114KRDS-BKE#7	7007CDP4ADGA	SKF	107KRDS-BKE#7
3MM9115WIDUL	FAF	7115KRDS-BKE#7	7007CTDULP4	NSK	107KRDS-BKE#7
3MM9116WIDUL	FAF	7116KRDS-BKE#7	7008ACDP4ADGA	SKF	7108KRDS-BKE#7
3MM9117WIDUL	FAF	7117KRDS-BKE#7	7008A5TDULP4	NSK	7108KRDS-BKE#7
3MM9118WIDUL	FAF	7118KRDS-BKE#7	7008CDP4ADGA	SKF	108KRDS-BKE#7
3MM9120WIDUL	FAF	7120KRDS-BKE#7	7008CTDULP4	NSK	108KRDS-BKE#7
3MM9122WIDUL	FAF	7122KRDS-BKE#7	7009ACDP4ADGA	SKF	7109KRDS-BKE#7
3MM9124WIDUL	FAF	7124KRDS-BKE#7	7009A5TDULP4	NSK	7109KRDS-BKE#7
3MM9126WIDUL	FAF	7126KRDS-BKE#7	7009CDP4ADGA	SKF	109KRDS-BKE#7
3MM9128WIDUL	FAF	7128KRDS-BKE#7	7009CTDULP4	NSK	109KRDS-BKE#7
3MM9130WIDUL	FAF	7130KRDS-BKE#7	7010ACDP4ADGA	SKF	7110KRDS-BKE#7



Precision Angular Contact Ball Bearings With 15° and 25° Contact Angles

MFR No.	MFR	MRC	MFR No.	MFR	MRC
7010A5TDULP4	NSK	7110KRDS-BKE#7	7022A5TDULP4	NSK	7122KRDS-BKE#7
7010CDP4ADGA	SKF	110KRDS-BKE#7	7022CDP4ADGA	SKF	122KRDS-BKE#7
7010CTDULP4	NSK	110KRDS-BKE#7	7022CTDULP4	NSK	122KRDS-BKE#7
7011ACDP4ADGA	SKF	7111KRDS-BKE#7	7024ACDP4ADGA	SKF	7124KRDS-BKE#7
7011A5TDULP4	NSK	7111KRDS-BKE#7	7024A5TDULP4	NSK	7124KRDS-BKE#7
7011CDP4ADGA	SKF	111KRDS-BKE#7	7024CDP4ADGA	SKF	124KRDS-BKE#7
7011CTDULP4	NSK	111KRDS-BKE#7	7024CTDULP4	NSK	124KRDS-BKE#7
7012ACDP4ADGA	SKF	7112KRDS-BKE#7	7026ACDP4ADGA	SKF	7126KRDS-BKE#7
7012A5TDULP4	NSK	7112KRDS-BKE#7	7026A5TDULP4	NSK	7126KRDS-BKE#7
7012CDP4ADGA	SKF	112KRDS-BKE#7	7026CDP4ADGA	SKF	126KRDS-BKE#7
7012CTDULP4	NSK	112KRDS-BKE#7	7026CTDULP4	NSK	126KRDS-BKE#7
7013ACDP4ADGA	SKF	7113KRDS-BKE#7	7028ACDP4ADGA	SKF	7128KRDS-BKE#7
7013A5TDULP4	NSK	7113KRDS-BKE#7	7028A5TDULP4	NSK	7128KRDS-BKE#7
7013CDP4ADGA	SKF	113KRDS-BKE#7	7028CDP4ADGA	SKF	128KRDS-BKE#7
7013CTDULP4	NSK	113KRDS-BKE#7	7028CTDULP4	NSK	128KRDS-BKE#7
7014ACDP4ADGA	SKF	7114KRDS-BKE#7	7030ACDP4ADGA	SKF	7130KRDS-BKE#7
7014A5TDULP4	NSK	7114KRDS-BKE#7	7030A5TDULP4	NSK	7130KRDS-BKE#7
7014CDP4ADGA	SKF	114KRDS-BKE#7	7030CDP4ADGA	SKF	130KRDS-BKE#7
7014CTDULP4	NSK	114KRDS-BKE#7	7030CTDULP4	NSK	130KRDS-BKE#7
7015ACDP4ADGA	SKF	7115KRDS-BKE#7	7032CDP4ADGA	SKF	132KRDS-BKE#7
7015A5TDULP4	NSK	7115KRDS-BKE#7	7032CTDULP4	NSK	132KRDS-BKE#7
7015CDP4ADGA	SKF	115KRDS-BKE#7	7034CDP4ADGA	SKF	134KRDS-BKE#7
7015CTDULP4	NSK	115KRDS-BKE#7	7034CTDULP4	NSK	134KRDS-BKE#7
7016ACDP4ADGA	SKF	7116KRDS-BKE#7	7036CDP4ADGA	SKF	136KRDS-BKE#7
7016A5TDULP4	NSK	7116KRDS-BKE#7	7036CTDULP4	NSK	136KRDS-BKE#7
7016CDP4ADGA	SKF	116KRDS-BKE#7	7038CDP4ADGA	SKF	138KRDS-BKE#7
7016CTDULP4	NSK	116KRDS-BKE#7	7038CTDULP4	NSK	138KRDS-BKE#7
7017ACDP4ADGA	SKF	7117KRDS-BKE#7	7040CDP4ADGA	SKF	140KRDS-BKE#7
7017A5TDULP4	NSK	7117KRDS-BKE#7	7040CTDULP4	NSK	140KRDS-BKE#7
7017CDP4ADGA	SKF	117KRDS-BKE#7	7044CDP4ADGA	SKF	144KRDS-BKE#7
7017CTDULP4	NSK	117KRDS-BKE#7	71900ACDP4ADGA	SKF	71900DS-BKE#7
7018ACDP4ADGA	SKF	7118KRDS-BKE#7	71900CDP4ADGA	SKF	1900RDS-BKE#7
7018A5TDULP4	NSK	7118KRDS-BKE#7	71901ACDP4ADGA	SKF	71901DS-BKE#7
7018CDP4ADGA	SKF	118KRDS-BKE#7	71901CDP4ADGA	SKF	1901RDS-BKE#7
7018CTDULP4	NSK	118KRDS-BKE#7	71902ACDP4ADGA	SKF	71902DS-BKE#7
7019ACDP4ADGA	SKF	7119KRDS-BKE#7	71902CDP4ADGA	SKF	1902RDS-BKE#7
7019A5TDULP4	NSK	7119KRDS-BKE#7	71903ACDP4ADGA	SKF	71903DS-BKE#7
7019CDP4ADGA	SKF	119KRDS-BKE#7	71903CDP4ADGA	SKF	1903RDS-BKE#7
7019CTDULP4	NSK	119KRDS-BKE#7	71904ACDP4ADGA	SKF	71904DS-BKE#7
7020ACDP4ADGA	SKF	7120KRDS-BKE#7	71904CDP4ADGA	SKF	1904RDS-BKE#7
7020A5TDULP4	NSK	7120KRDS-BKE#7	71905ACDP4ADGA	SKF	71905DS-BKE#7
7020CDP4ADGA	SKF	120KRDS-BKE#7	71905CDP4ADGA	SKF	1905RDS-BKE#7
7020CTDULP4	NSK	120KRDS-BKE#7	71906ACDP4ADGA	SKF	71906DS-BKE#7
7021ACDP4ADGA	SKF	7121KRDS-BKE#7	71906CDP4ADGA	SKF	1906RDS-BKE#7
7021A5TDULP4	NSK	7121KRDS-BKE#7	71907ACDP4ADGA	SKF	71907DS-BKE#7
7021CDP4ADGA	SKF	121KRDS-BKE#7	71907CDP4ADGA	SKF	1907RDS-BKE#7
7021CTDULP4	NSK	121KRDS-BKE#7	71908ACDP4ADGA	SKF	71908DS-BKE#7
7022ACDP4ADGA	SKF	7122KRDS-BKE#7	71908CDP4ADGA	SKF	1908RDS-BKE#7

Precision Angular Contact Ball Bearings With 15° and 25° Contact Angles

MRC Machine Tools

MFR No.	MFR	MRC	MFR No.	MFR	MRC
71909ACDP4ADGA	SKF	71909DS-BKE#7	7206CDP4ADGA	SKF	206RDS-BKE#7
71909CDP4ADGA	SKF	1909RDS-BKE#7	7206CTDULP4	NSK	206RDS-BKE#7
71910ACDP4ADGA	SKF	71910DS-BKE#7	7207ACDP4ADGA	SKF	7207DS-BKE#7
71910CDP4ADGA	SKF	1910RDS-BKE#7	7207A5TDULP4	NSK	7207DS-BKE#7
71911ACDP4ADGA	SKF	71911DS-BKE#7	7207CDP4ADGA	SKF	207RDS-BKE#7
71911CDP4ADGA	SKF	1911RDS-BKE#7	7207CTDULP4	NSK	207RDS-BKE#7
71912ACDP4ADGA	SKF	71912DS-BKE#7	7208ACDP4ADGA	SKF	7208DS-BKE#7
71912CDP4ADGA	SKF	1912RDS-BKE#7	7208A5TDULP4	NSK	7208DS-BKE#7
71913ACDP4ADGA	SKF	71913DS-BKE#7	7208CDP4ADGA	SKF	208RDS-BKE#7
71913CDP4ADGA	SKF	1913RDS-BKE#7	7208CTDULP4	NSK	208RDS-BKE#7
71914ACDP4ADGA	SKF	71914DS-BKE#7	7209ACDP4ADGA	SKF	7209DS-BKE#7
71914CDP4ADGA	SKF	1914RDS-BKE#7	7209A5TDULP4	NSK	7209DS-BKE#7
71915ACDP4ADGA	SKF	71915DS-BKE#7	7209CDP4ADGA	SKF	209RDS-BKE#7
71915CDP4ADGA	SKF	1915RDS-BKE#7	7209CTDULP4	NSK	209RDS-BKE#7
71916ACDP4ADGA	SKF	71916DS-BKE#7	7210ACDP4ADGA	SKF	7210DS-BKE#7
71916CDP4ADGA	SKF	1916RDS-BKE#7	7210A5TDULP4	NSK	7210DS-BKE#7
71917CDP4ADGA	SKF	1917RDS-BKE#7	7210CDP4ADGA	SKF	210RDS-BKE#7
71918CDP4ADGA	SKF	1918RDS-BKE#7	7210CTDULP4	NSK	210RDS-BKE#7
71919CDP4ADGA	SKF	1919RDS-BKE#7	7211ACDP4ADGA	SKF	7211DS-BKE#7
71920CDP4ADGA	SKF	1920RDS-BKE#7	7211A5TDULP4	NSK	7211DS-BKE#7
71921CDP4ADGA	SKF	1921RDS-BKE#7	7211CDP4ADGA	SKF	211RDS-BKE#7
71922CDP4ADGA	SKF	1922RDS-BKE#7	7211CTDULP4	NSK	211RDS-BKE#7
71924CDP4ADGA	SKF	1924RDS-BKE#7	7212ACDP4ADGA	SKF	7212DS-BKE#7
71926CDP4ADGA	SKF	1926RDS-BKE#7	7212A5TDULP4	NSK	7212DS-BKE#7
71928CDP4ADGA	SKF	1928RDS-BKE#7	7212CDP4ADGA	SKF	212RDS-BKE#7
71930CDP4ADGA	SKF	1930RDS-BKE#7	7212CTDULP4	NSK	212RDS-BKE#7
7200CDP4ADGA	SKF	200RDS-BKE#7	7213ACDP4ADGA	SKF	7213DS-BKE#7
7200CTDULP4	NSK	200RDS-BKE#7	7213A5TDULP4	NSK	7213DS-BKE#7
7201CDP4ADGA	SKF	201RDS-BKE#7	7213CDP4ADGA	SKF	213RDS-BKE#7
7201CTDULP4	NSK	201RDS-BKE#7	7213CTDULP4	NSK	213RDS-BKE#7
7202ACDP4ADGA	SKF	7202DS-BKE#7	7214ACDP4ADGA	SKF	7214DS-BKE#7
7202A5TDULP4	NSK	7202DS-BKE#7	7214A5TDULP4	NSK	7214DS-BKE#7
7202CDP4ADGA	SKF	202RDS-BKE#7	7214CDP4ADGA	SKF	214RDS-BKE#7
7202CTDULP4	NSK	202RDS-BKE#7	7214CTDULP4	NSK	214RDS-BKE#7
7203ACDP4ADGA	SKF	7203DS-BKE#7	7215CDP4ADGA	SKF	215RDS-BKE#7
7203A5TDULP4	NSK	7203DS-BKE#7	7215CTDULP4	NSK	215RDS-BKE#7
7203CDP4ADGA	SKF	203RDS-BKE#7	7216CDP4ADGA	SKF	216RDS-BKE#7
7203CTDULP4	NSK	203RDS-BKE#7	7216CTDULP4	NSK	216RDS-BKE#7
7204ACDP4ADGA	SKF	7204DS-BKE#7	7217CDP4ADGA	SKF	217RDS-BKE#7
7204A5TDULP4	NSK	7204DS-BKE#7	7217CTDULP4	NSK	217RDS-BKE#7
7204CDP4ADGA	SKF	204RDS-BKE#7	7218CDP4ADGA	SKF	218RDS-BKE#7
7204CTDULP4	NSK	204RDS-BKE#7	7218CTDULP4	NSK	218RDS-BKE#7
7205ACDP4ADGA	SKF	7205DS-BKE#7	7219CDP4ADGA	SKF	219RDS-BKE#7
7205A5TDULP4	NSK	7205DS-BKE#7	7219CTDULP4	NSK	219RDS-BKE#7
7205CDP4ADGA	SKF	205RDS-BKE#7	7220CDP4ADGA	SKF	220RDS-BKE#7
7205CTDULP4	NSK	205RDS-BKE#7	7220CTDULP4	NSK	220RDS-BKE#7
7206ACDP4ADGA	SKF	7206DS-BKE#7	7222CDP4ADGA	SKF	222RDS-BKE#7
7206A5TDULP4	NSK	7206DS-BKE#7	7222CTDULP4	NSK	222RDS-BKE#7



Precision Angular Contact Ball Bearings With 15° and 25° Contact Angles

MFR No.	MFR	MRC	MFR No.	MFR	MRC
7224CDP4ADGA	SKF	224RDS-BKE#7	7916CTDULP4	NSK	1916RDS-BKE#7
7224CTDULP4	NSK	224RDS-BKE#7	7917CTDULP4	NSK	1917RDS-BKE#7
7300CDP4ADGA	SKF	300RDS-BKE#7	7918CTDULP4	NSK	1918RDS-BKE#7
7301CDP4ADGA	SKF	301RDS-BKE#7	7919CTDULP4	NSK	1919RDS-BKE#7
7302CDP4ADGA	SKF	302RDS-BKE#7	7920CTDULP4	NSK	1920RDS-BKE#7
7303CDP4ADGA	SKF	303RDS-BKE#7	7921CTDULP4	NSK	1921RDS-BKE#7
7304CDP4ADGA	SKF	304RDS-BKE#7	7922CTDULP4	NSK	1922RDS-BKE#7
7305CDP4ADGA	SKF	305RDS-BKE#7	7924CTDULP4	NSK	1924RDS-BKE#7
7306CDP4ADGA	SKF	306RDS-BKE#7	7926CTDULP4	NSK	1926RDS-BKE#7
7307CDP4ADGA	SKF	307RDS-BKE#7	7928CTDULP4	NSK	1928RDS-BKE#7
7308CDP4ADGA	SKF	308RDS-BKE#7	7930CTDULP4	NSK	1930RDS-BKE#7
7309CDP4ADGA	SKF	309RDS-BKE#7			
7310CDP4ADGA	SKF	310RDS-BKE#7			
7311CDP4ADGA	SKF	311RDS-BKE#7			
7312CDP4ADGA	SKF	312RDS-BKE#7			
7900A5TDULP4	NSK	71900DS-BKE#7			
7900CTDULP4	NSK	1900RDS-BKE#7			
7901A5TDULP4	NSK	71901DS-BKE#7			
7901CTDULP4	NSK	1901RDS-BKE#7			
7902A5TDULP4	NSK	71902DS-BKE#7			
7902CTDULP4	NSK	1902RDS-BKE#7			
7903A5TDULP4	NSK	71903DS-BKE#7			
7903CTDULP4	NSK	1903RDS-BKE#7			
7904A5TDULP4	NSK	71904DS-BKE#7			
7904CTDULP4	NSK	1904RDS-BKE#7			
7905A5TDULP4	NSK	71905DS-BKE#7			
7905CTDULP4	NSK	1905RDS-BKE#7			
7906A5TDULP4	NSK	71906DS-BKE#7			
7906CTDULP4	NSK	1906RDS-BKE#7			
7907A5TDULP4	NSK	71907DS-BKE#7			
7907CTDULP4	NSK	1907RDS-BKE#7			
7908A5TDULP4	NSK	71908DS-BKE#7			
7908CTDULP4	NSK	1908RDS-BKE#7			
7909A5TDULP4	NSK	71909DS-BKE#7			
7909CTDULP4	NSK	1909RDS-BKE#7			
7910A5TDULP4	NSK	71910DS-BKE#7			
7910CTDULP4	NSK	1910RDS-BKE#7			
7911A5TDULP4	NSK	71911DS-BKE#7			
7911CTDULP4	NSK	1911RDS-BKE#7			
7912A5TDULP4	NSK	71912DS-BKE#7			
7912CTDULP4	NSK	1912RDS-BKE#7			
7913A5TDULP4	NSK	71913DS-BKE#7			
7913CTDULP4	NSK	1913RDS-BKE#7			
7914A5TDULP4	NSK	71914DS-BKE#7			
7914CTDULP4	NSK	1914RDS-BKE#7			
7915A5TDULP4	NSK	71915DS-BKE#7			
7915CTDULP4	NSK	1915RDS-BKE#7			
7916A5TDULP4	NSK	71916DS-BKE#7			

Precision Double Row, Tapered Bore Cylindrical Roller Bearings

MRC Machine Tools

MFR No.	MFR	MRC	MFR No.	MFR	MRC
NN3007ASKMSP	FAG	NN3107X	NN3016KTN9/SPW33	SKF	NN3116X
NN3007K	NAC	NN3107X	NN3016MBKR	NSK	NN3116X
NN3007K	NTN	NN3107X	NN3017ASKMSP	FAG	NN3117X
NN3007KSP	SKF	NN3107X	NN3017K	NAC	NN3117X
NN3007MBKR	NSK	NN3107X	NN3017K	NTN	NN3117X
NN3008ASKMSP	FAG	NN3108X	NN3017KTN9/SPW33	SKF	NN3117X
NN3008K	NAC	NN3108X	NN3017MBKR	NSK	NN3117X
NN3008K	NTN	NN3108X	NN3018ASKMSP	FAG	NN3118X
NN3008KTNSP	SKF	NN3108X	NN3018K	NAC	NN3118X
NN3008MBKR	NSK	NN3108X	NN3018K	NTN	NN3118X
NN3009ASKMSP	FAG	NN3109X	NN3018KTN9/SPW33	SKF	NN3118X
NN3009K	NAC	NN3109X	NN3018MBKR	NSK	NN3118X
NN3009K	NTN	NN3109X	NN3019ASKMSP	FAG	NN3119X
NN3009KTNSP	SKF	NN3109X	NN3019K	NAC	NN3119X
NN3009MBKR	NSK	NN3109X	NN3019K	NTN	NN3119X
NN3010ASKMSP	FAG	NN3110X	NN3019KTN9/SPW38	SKF	NN3119X
NN3010K	NAC	NN3110X	NN3019MBKR	NSK	NN3119X
NN3010K	NTN	NN3110X	NN3020ASKMSP	FAG	NN3120X
NN3010KTN/SPW33	SKF	NN3110X	NN3020K	NAC	NN3120X
NN3010MBKR	NSK	NN3110X	NN3020K	NTN	NN3120X
NN3011ASKMSP	FAG	NN3111X	NN3020KTN9/SPW33	SKF	NN3120X
NN3011K	NAC	NN3111X	NN3020MBKR	NSK	NN3120X
NN3011K	NTN	NN3111X	NN3021ASKMSP	FAG	NN3121X
NN3011KTN/SPW33	SKF	NN3111X	NN3021K	NAC	NN3121X
NN3011MBKR	NSK	NN3111X	NN3021K	NTN	NN3121X
NN3012ASKMSP	FAG	NN3112X	NN3021KTN9/SPW33	SKF	NN3121X
NN3012K	NAC	NN3112X	NN3021MBKR	NSK	NN3121X
NN3012K	NTN	NN3112X	NN3022ASKMSP	FAG	NN3122X
NN3012KTN/SPW33	SKF	NN3112X	NN3022K	NAC	NN3122X
NN3012MBKR	NSK	NN3112X	NN3022K	NTN	NN3122X
NN3013ASKMSP	FAG	NN3113X	NN3022KTN9/SPW33	SKF	NN3122X
NN3013K	NAC	NN3113X	NN3022MBKR	NSK	NN3122X
NN3013K	NTN	NN3113X	NN3024ASKMSP	FAG	NN3124X
NN3013KTN/SPW33	SKF	NN3113X	NN3024K	NAC	NN3124X
NN3013MBKR	NSK	NN3113X	NN3024K	NTN	NN3124X
NN3014ASKMSP	FAG	NN3114X	NN3024KTN9/SPW33	SKF	NN3124X
NN3014K	NAC	NN3114X	NN3024MBKR	NSK	NN3124X
NN3014K	NTN	NN3114X	NN3026ASKMSP	FAG	NN3126X
NN3014KTN/SPW33	SKF	NN3114X	NN3026K	NAC	NN3126X
NN3014MBKR	NSK	NN3114X	NN3026K	NTN	NN3126X
NN3015ASKMSP	FAG	NN3115X	NN3026KTN9/SPW33	SKF	NN3126X
NN3015K	NAC	NN3115X	NN3026MBKR	NSK	NN3126X
NN3015K	NTN	NN3115X	NN3028ASKMSP	FAG	NN3128X
NN3015KTN9/SPW33	SKF	NN3115X	NN3028K	NAC	NN3128X
NN3015MBKR	NSK	NN3115X	NN3028K	NTN	NN3128X
NN3016ASKMSP	FAG	NN3116X	NN3028KSPW33	SKF	NN3128X
NN3016K	NAC	NN3116X	NN3028MBKR	NSK	NN3128X
NN3016K	NTN	NN3116X	NN3030ASKMSP	FAG	NN3130X

MFR No.	MFR	MRC
NN3030K	NAC	NN3130X
NN3030K	NTN	NN3130X
NN3030KSPW33	SKF	NN3130X
NN3030MBKR	NSK	NN3130X
NN3032ASKMSP	FAG	NN3132X
NN3032K	NAC	NN3132X
NN3032K	NTN	NN3132X
NN3032KSPW33	SKF	NN3132X
NN3032MBKR	NSK	NN3132X

Ball Screw Support Bearings

MRC Machine Tools

MFR No.	MFR	MRC
BDAB634201CGB	SKF	J093
BDAB634203CGA	SKF	J175
BSA201CGA	SKF	J1232
BSA202CGA	SKF	J1535
BSA204CGB	SKF	J2047
BSA205CGA	SKF	J2552
BSA206CGA	SKF	J3062
BSB020047	RHP	J2047A
BSB020047T	FAG	J2047A
BSB025062	RHP	J2562
BSB025062T	FAG	J2562
BSB030062	RHP	J3062A
BSB030062T	FAG	J3062A
BSB035072	RHP	J3572
BSB035072T	FAG	J3572
BSB040072	RHP	J4072
BSB040072T	FAG	J4072
BSB093	RHP	J093
BSB175	RHP	J175
BSD2047CDGA	SKF	J2047A
BSD2562CDGA	SKF	J2562
BSB3062CDGA	SKF	J3062A
BSB3572CDGA	SKF	J3572
BSB4072CDGA	SKF	J4072
L093H	BAR	J093
L175H	BAR	J175
MM20BS47	FAF	J2047A
MM25BS62	FAF	J2562
MM30BS62	FAF	J3062A
MM35BS72	FAF	J3572
MM40BS72	FAF	J4072
MM9308W1-2	FAF	J093
MM9311W1-3	FAF	J175
20TAB04	NAC	J2047A
20TAC47	NSK	J2047A
25TAB06	NAC	J2562
25TAC62	NSK	J2562
30TAB06	NAC	J3062A
30TAC62	NSK	J3062A
35TAB07	NAC	J3572
35TAC72	NSK	J3572
40TAB07	NAC	J4072
40TAC72	NSK	J4072
44TAC76	NSK	J175

MFR No.	MFR	MRC	MFR No.	MFR	MRC
100TAD20	NAC	DT120	234430BMI/SP	SKF	DT130
105TAD20	NAC	DT121	234430MSP	FAG	DT130
110TAD20	NAC	DT122	234432BMI/SP	SKF	DT132
120TAD20	NAC	DT124	234432MSP	FAG	DT132
130TAD20	NAC	DT126	234434BMI/SP	SKF	DT134
140TAD20	NAC	DT128	234434MSP	FAG	DT134
150TAD20	NAC	DT130	234436BMI/SP	SKF	DT136
160TAD20	NAC	DT132	234436MSP	FAG	DT136
170TAD20	NAC	DT134	234438BMI/SP	SKF	DT138
180TAD20	NAC	DT136	234438MSP	FAG	DT138
190TAD20	NAC	DT138	234440BMI/SP	SKF	DT140
200TAD20	NAC	DT140	234440MSP	FAG	DT140
234408BMI/SP	SKF	DT108	40TAD20	NAC	DT108
234408MSP	FAG	DT108	45TAD20	NAC	DT109
234409BMI/SP	SKF	DT109	50TAD20	NAC	DT110
234409MSP	FAG	DT109	55TAD20	NAC	DT111
234410BMI/SP	SKF	DT110	60TAD20	NAC	DT112
234410MSP	FAG	DT110	65TAD20	NAC	DT113
234411BMI/SP	SKF	DT111	70TAD20	NAC	DT114
234411MSP	FAG	DT111	75TAD20	NAC	DT115
234412MSP	FAG	DT112	80TAD20	NAC	DT116
234412TN9/SP	SKF	DT112	85TAD20	NAC	DT117
234413MSP	FAG	DT113	90TAD20	NAC	DT118
234413TN9/SP	SKF	DT113	95TAD20	NAC	DT119
234414MSP	FAG	DT114			
234414TN9/SP	SKF	DT114			
234415BMI/SP	SKF	DT115			
234415MSP	FAG	DT115			
234416MSP	FAG	DT116			
234416TN9/SP	SKF	DT116			
234417MSP	FAG	DT117			
234417TN9/SP	SKF	DT117			
234418MSP	FAG	DT118			
234418TN9/SP	SKF	DT118			
234419MSP	FAG	DT119			
234419TN9/SP	SKF	DT119			
234420MSP	FAG	DT120			
234420TN9/SP	SKF	DT120			
234421BMI/SP	SKF	DT121			
234421MSP	FAG	DT121			
234422BMI/SP	SKF	DT122			
234422MSP	FAG	DT122			
234424MSP	FAG	DT124			
234424TN9/SP	SKF	DT124			
234426MSP	FAG	DT126			
234426TN9/SP	SKF	DT126			
234428BMI/SP	SKF	DT128			
234428MSP	FAG	DT128			

Profile Rail Guides

MRC Machine Tools

MFR No.	MFR	MRC
CG20AA	THO	LLBHS20A/TA/B/TB
CG20BA	THO	LLBHS20LA/LB
CG20CE	THO	LLBHS20R
CG20DE	THO	LLBHS20LR
CG25AA	THO	LLBHS25A/TA/B/TB
CG25BA	THO	LLBHS25LA/LB
CG25CE	THO	LLBHS25R
CG25DE	THO	LLBHS25LR
CG30AA	THO	LLBHS30A/TA/B/TB
CG30BA	THO	LLBHS30LA/LB
CG30CE	THO	LLBHS30R
CG30DE	THO	LLBHS30LR
CG35AA	THO	LLBHS35A/TA/B/TB
CG35BA	THO	LLBHS35LA/LB
CG35CE	THO	LLBHS35R
CG35DE	THO	LLBHS35LR
CG45AA	THO	LLBHS45A/TA/B/TB
CG45BA	THO	LLBHS45LA/LB
CG45CE	THO	LLBHS45R
CG45DE	THO	LLBHS45LR
HSR15A	THK	LLBHS15A/TA
HSR15B	THK	LLBHS15B/TB
HSR15CA	THK	LLBHS15A/TA
HSR15CB	THK	LLBHS15B/TB
HSR15CR	THK	LLBHS15R
HSR15HA	THK	LLBHS15LA
HSR15HB	THK	LLBHS15LB
HSR15HR	THK	LLBHS15LR
HSR15HTA	THK	LLBHS15LA
HSR15HTB	THK	LLBHS15LB
HSR15HTR	THK	LLBHS15LR
HSR15LA	THK	LLBHS15LA
HSR15LB	THK	LLBHS15LB
HSR15LR	THK	LLBHS15LR
HSR15R	THK	LLBHS15R
HSR15TA	THK	LLBHS15A/TA
HSR15TB	THK	LLBHS15B/TB
HSR15TR	THK	LLBHS15R
HSR20A	THK	LLBHS20A/TA
HSR20B	THK	LLBHS20B/TB
HSR20CA	THK	LLBHS20A/TA
HSR20CB	THK	LLBHS20B/TB
HSR20CR	THK	LLBHS20R
HSR20HA	THK	LLBHS20LA
HSR20HB	THK	LLBHS20LB
HSR20HR	THK	LLBHS20LR
HSR20HTA	THK	LLBHS20LA
HSR20HTB	THK	LLBHS20LB

MFR No.	MFR	MRC
HSR0HTR	THK	LLBHS20LR
HSR20LA	THK	LLBHS20LA
HSR20LB	THK	LLBHS20LB
HSR20LR	THK	LLBHS20LR
HSR20R	THK	LLBHS20R
HSR20TA	THK	LLBHS20A/TA
HSR20TB	THK	LLBHS20B/TB
HSR20TR	THK	LLBHS20R
HSR25A	THK	LLBHS25A/TA
HSR25B	THK	LLBHS25B/TB
HSR25CA	THK	LLBHS25A/TA
HSR25CB	THK	LLBHS25B/TB
HSR25CR	THK	LLBHS25R
HSR25HA	THK	LLBHS25LA
HSR25HB	THK	LLBHS25LB
HSR25HR	THK	LLBHS25LR
HSR25HTA	THK	LLBHS25LA
HSR25HTB	THK	LLBHS25LB
HSR25HTR	THK	LLBHS25LR
HSR25LA	THK	LLBHS25LA
HSR25LB	THK	LLBHS25LB
HSR25LR	THK	LLBHS25LR
HSR25R	THK	LLBHS25R
HSR25TA	THK	LLBHS25A/TA
HSR25TB	THK	LLBHS25B/TB
HSR25TR	THK	LLBHS25R
HSR30A	THK	LLBHS30A/TA
HSR30B	THK	LLBHS30B/TB
HSR30CA	THK	LLBHS30A/TA
HSR30CB	THK	LLBHS30B/TB
HSR30CR	THK	LLBHS30R
HSR30HA	THK	LLBHS30LA
HSR30HB	THK	LLBHS30LB
HSR30HR	THK	LLBHS30LR
HSR30HTA	THK	LLBHS30LA
HSR30HTB	THK	LLBHS30LB
HSR30HTR	THK	LLBHS30LR
HSR30LA	THK	LLBHS30LA
HSR30LB	THK	LLBHS30LB
HSR30LR	THK	LLBHS30LR
HSR30R	THK	LLBHS30R
HSR30TA	THK	LLBHS30A/TA
HSR30TB	THK	LLBHS30B/TB
HSR30TR	THK	LLBHS30R
HSR35A	THK	LLBHS35A/TA
HSR35B	THK	LLBHS35B/TB
HSR35CA	THK	LLBHS35A/TA
HSR35CB	THK	LLBHS35B/TB

MFR No.	MFR	MRC	MFR No.	MFR	MRC
HSR35CR	THK	LLBHS35R	HSR55TB	THK	LLBHS55B/TB
HSR35HA	THK	LLBHS35LA	HSR55TR	THK	LLBHS55R
HSR35HB	THK	LLBHS35LB	LAH20AN	NSK	LLBHS20R
HSR35HR	THK	LLBHS35LR	LAH20BN	NSK	LLBHS20LR
HSR35HTA	THK	LLBHS35LA	LAH20EL	NSK	LLBHS20A/TA/B/TB
HSR35HTB	THK	LLBHS35LB	LAH20GL	NSK	LLBHS20LA/LB
HSR35HTR	THK	LLBHS35LR	LAH25AN	NSK	LLBHS25R
HSR35LA	THK	LLBHS35LA	LAH25BN	NSK	LLBHS25LR
HSR35LB	THK	LLBHS35LB	LAH25EL	NSK	LLBHS25A/TA/B/TB
HSR35LR	THK	LLBHS35LR	LAH25GL	NSK	LLBHS25LA/LB
HSR35R	THK	LLBHS35R	LAH30AN	NSK	LLBHS30R
HSR35TA	THK	LLBHS35A/TA	LAH30BN	NSK	LLBHS30LR
HSR35TB	THK	LLBHS35B/TB	LAH30EL	NSK	LLBHS30A/TA/B/TB
HSR35TR	THK	LLBHS35R	LAH30GL	NSK	LLBHS30LA/LB
HSR45A	THK	LLBHS45A/TA	LAH35AN	NSK	LLBHS35R
HSR45B	THK	LLBHS45B/TB	LAH35BN	NSK	LLBHS35LR
HSR45CA	THK	LLBHS45A/TA	LAH35EL	NSK	LLBHS35A/TA/B/TB
HSR45CB	THK	LLBHS45B/TB	LAH35GL	NSK	LLBHS35LA/LB
HSR45CR	THK	LLBHS45R	LAH45AN	NSK	LLBHS45R
HSR45HA	THK	LLBHS45LA	LAH45BN	NSK	LLBHS45LR
HSR45HB	THK	LLBHS45LB	LAH45EL	NSK	LLBHS45A/TA/B/TB
HSR45HR	THK	LLBHS45LR	LAH45GL	NSK	LLBHS45LA/LB
HSR45HTA	THK	LLBHS45LA	LAH55AN	NSK	LLBHS55R
HSR45HTB	THK	LLBHS45LB	LAH55BN	NSK	LLBHS55LR
HSR45HTR	THK	LLBHS45LR	LAH55EL	NSK	LLBHS55A/TA/B/TB
HSR45LA	THK	LLBHS45LA	LAH55GL	NSK	LLBHS55LA/LB
HSR45LB	THK	LLBHS45LB	LAS15AL	NSK	LLBUS15R
HSR45LR	THK	LLBHS45LR	LAS15CL	NSK	LLBUS15SR
HSR45R	THK	LLBHS45R	LAS20AL	NSK	LLBUS20R
HSR45TA	THK	LLBHS45A/TA	LAS20CL	NSK	LLBUS20SR
HSR45TB	THK	LLBHS45B/TB	LAS25AL	NSK	LLBUS25R
HSR45TR	THK	LLBHS45R	LAS25CL	NSK	LLBUS25SR
HSR55A	THK	LLBHS55A/TA	LAS30AL	NSK	LLBUS30R
HSR55B	THK	LLBHS55B/TB	LAS30CL	NSK	LLBUS30SR
HSR55CA	THK	LLBHS55A/TA	LAS35AL	NSK	LLBUS35R
HSR55CB	THK	LLBHS55B/TB	LAS35CL	NSK	LLBUS35SR
HSR55CR	THK	LLBHS55R	LLBHS15A	SKF	LLBHS15A
HSR55HA	THK	LLBHS55LA	LLBHS15B	SKF	LLBHS15B
HSR55HB	THK	LLBHS55LB	LLBHS15LA	SKF	LLBHS15LA
HSR55HR	THK	LLBHS55LR	LLBHS15LB	SKF	LLBHS15LB
HSR55HTA	THK	LLBHS55LA	LLBHS15LR	SKF	LLBHS15LR
HSR55HTB	THK	LLBHS55LB	LLBHS15R	SKF	LLBHS15R
HSR55HTR	THK	LLBHS55LR	LLBHS15TA	SKF	LLBHS15TA
HSR55LA	THK	LLBHS55LA	LLBHS15TB	SKF	LLBHS15TB
HSR55LB	THK	LLBHS55LB	LLBHS20A	SKF	LLBHS20A
HSR55LR	THK	LLBHS55LR	LLBHS20B	SKF	LLBHS20B
HSR55R	THK	LLBHS55R	LLBHS20LA	SKF	LLBHS20LA
HSR55TA	THK	LLBHS55A/TA	LLBHS20LB	SKF	LLBHS20LB

Profile Rail Guides

MRC Machine Tools

MFR No.	MFR	MRC
LLBHS20LR	SKF	LLBHS20LR
LLBHS20R	SKF	LLBHS20R
LLBHS20TA	SKF	LLBHS20TA
LLBHS20TB	SKF	LLBHS20TB
LLBHS25A	SKF	LLBHS25A
LLBHS25B	SKF	LLBHS25B
LLBHS25LA	SKF	LLBHS25LA
LLBHS25LB	SKF	LLBHS25LB
LLBHS25LR	SKF	LLBHS25LR
LLBHS25R	SKF	LLBHS25R
LLBHS25TA	SKF	LLBHS25TA
LLBHS25TB	SKF	LLBHS25TB
LLBHS30A	SKF	LLBHS30A
LLBHS30B	SKF	LLBHS30B
LLBHS30LA	SKF	LLBHS30LA
LLBHS30LB	SKF	LLBHS30LB
LLBHS30LR	SKF	LLBHS30LR
LLBHS30R	SKF	LLBHS30R
LLBHS30TA	SKF	LLBHS30TA
LLBHS30TB	SKF	LLBHS30TB
LLBHS35A	SKF	LLBHS35A
LLBHS35B	SKF	LLBHS35B
LLBHS35LA	SKF	LLBHS35LA
LLBHS35LB	SKF	LLBHS35LB
LLBHS35LR	SKF	LLBHS35LR
LLBHS35R	SKF	LLBHS35R
LLBHS35TA	SKF	LLBHS35TA
LLBHS35TB	SKF	LLBHS35TB
LLBHS45A	SKF	LLBHS45A
LLBHS45B	SKF	LLBHS45B
LLBHS45LA	SKF	LLBHS45LA
LLBHS45LB	SKF	LLBHS45LB
LLBHS45LR	SKF	LLBHS45LR
LLBHS45R	SKF	LLBHS45R
LLBHS45TA	SKF	LLBHS45TA
LLBHS45TB	SKF	LLBHS45TB
LLBHS55A	SKF	LLBHS55A
LLBHS55B	SKF	LLBHS55B
LLBHS55LA	SKF	LLBHS55LA
LLBHS55LB	SKF	LLBHS55LB
LLBHS55LR	SKF	LLBHS55LR
LLBHS55R	SKF	LLBHS55R
LLBHS55TA	SKF	LLBHS55TA
LLBHS55TB	SKF	LLBHS55TB
LLBUS15R	SKF	LLBUS15R
LLBUS15SR	SKF	LLBUS15SR
LLBUS20R	SKF	LLBUS20R
LLBUS20SR	SKF	LLBUS20SR

MFR No.	MFR	MRC
LLBUS25R	SKF	LLBUS25R
LLBUS25SR	SKF	LLBUS25SR
LLBUS30R	SKF	LLBUS30R
LLBUS30SR	SKF	LLBUS30SR
LLBUS35R	SKF	LLBUS35R
LLBUS35SR	SKF	LLBUS35SR
LLBUS45R	SKF	LLBUS45R
LLBUS45SR	SKF	LLBUS45SR
LLBUS55R	SKF	LLBUS55R
LLBUS55SR	SKF	LLBUS55SR
SR15V	THK	LLBUS15SR
SR15W	THK	LLBUS15R
SR20V	THK	LLBUS20SR
SR20W	THK	LLBUS20R
SR25V	THK	LLBUS25SR
SR25W	THK	LLBUS25R
SR30V	THK	LLBUS30SR
SR30W	THK	LLBUS30R
SR35V	THK	LLBUS35SR
SR35W	THK	LLBUS35R
SR45V	THK	LLBUS45SR
SR45W	THK	LLBUS45R
SR55V	THK	LLBUS55SR
SR55W	THK	LLBUS55R

Identification Symbols Following Basic Number

Preload

SKF	THK	THOMSON	NSK	MRC
T0		A	ZT	T0
T1	C1	B	ZZ-Z2	T1
T2	C0	C	Z3	T2
T3			Z4	T3

Accuracy Class

SKF	THK	THOMSON	NSK	MRC
P5		N	PC	P5
P3	H	H	P6	P3
P1	P	P	P5	P1
P01	SP	S	P4	P01
P001	UP	U	P3	P001

Seals

SKF	standard with side and bottom seals
THK	SS - end/bottom seals UU - end seals
THOMSON	LDS - end seals
NSK	standard with side and bottom seals
MRC	standard with side and bottom seals

The Following Requirements Must Be Provided:

- Length of rail track
- Number of slide units per rail track
- Number of rail tracks used in parallel

Numerical Order

Series designation	Product	Page
100 KRDS-BKE#7	Single Row 15° Angular Contact Duplex Ball Bearing	.30
1900 RDS-BKE#7	Single Row 15° Angular Contact Duplex Ball Bearing	.29
200 RDS-BKE#7	Single Row 15° Angular Contact Duplex Ball Bearing	.31
300 RDS-BKE#7	Single Row 15° Angular Contact Duplex Ball Bearing	.32
71900 DS-BKE#7	Single Row 25° Angular Contact Duplex Ball Bearing	.33
7100 KRDS-BKE#7	Single Row 25° Angular Contact Duplex Ball Bearing	.34
7200 DS-BKE#7	Single Row 25° Angular Contact Duplex Ball Bearing	.35

Alphabetical order

Series designation	Product	Page
BUF	Ball Screw End Bearing with Free Plummer Housing	96
DT100	Ball Screw Support Bearing	64
FLBU	Ball Screw End Bearing with Flanged Housing	90
J098-J4072	Single Direction Ball Screw Support Bearing	55
LLBHA..- G	Lubrication Plate for Profile Rail Guide	148
LLBHB	Bellows for Profile Rail Guide	130
LLBHS..A	Heavy Duty Profile Rail Guide	124
LLBHS..B	Heavy Duty Profile Rail Guide	126
LLBHS..LA	Heavy Duty Profile Rail Guide	124
LLBHS..LB	Heavy Duty Profile Rail Guide	126
LLBHS..LR	Heavy Duty Profile Rail Guide	128
LLBHS..R	Heavy Duty Profile Rail Guide	128
LLBHS..TA	High Performance Profile Rail Guide	116
LLBHS..TB	High Performance Profile Rail Guide	118
LLBHS..TR	High Performance Profile Rail Guide	120
LLBNS..TR	Medium Load Profile Rail Guide	134
LLBUS..R	Compact Profile Rail Guide	132
LLBUS..SR	Compact Profile Rail Guide	132
LLMHS..LA	Miniature Profile Rail Guide	145
LLMHS..TA	Miniature Profile Rail Guide	145
MTC	M Type Profile Rail Guide	140
MTW	M Type Profile Rail Guide	140
NN3100X	Double Row Cylindrical Roller Bearing with Tapered Bore	45
PGCL	Ball Screw Cylindrical Double Preloaded Nut	82
PGFE	Ball Screw Double Preloaded Flanged Nut	80
PGFJ	Ball Screw Flanged Nut with Internal Preload	74
PGFL	Ball Screw Double Preloaded Flanged Nut	76
PLBU	Ball Screw End Bearing with Fixed Plummer Housing	93
XO	Ex-Cell-O Spindle Bearing	37

Notes



MRC Bearing Services

1510 Gehman Road
Kulpsville, PA 19443

Call Toll Free 1 (800) MRC-7000
(215) 513-4400
Toll Free Fax: 1 (888) 322-4672
www.mrcbearingservices.com