

# Air-oil centralized lubrication systems

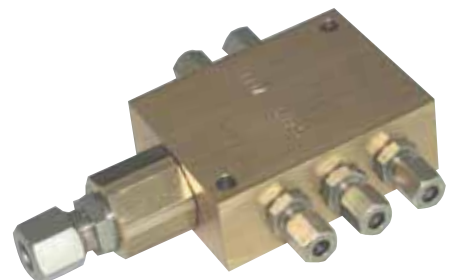

A lubrication system should always be as modern and efficient as the machine it is lubricating.

**Lincoln air-oil systems are ideally suited for this because they offer:**

- Optimal lubricant supply to the bearing
- Reduction in lubricant costs
- Environmental friendliness

# Air-oil centralized lubrication systems

## Advantages

- Reduced lubricant consumption: up to 1/100th of the quantity when compared to grease lubrication
- Continuous supply with fresh oil
- Increased bearing service life
- Positive pressure sealing of the bearing against contamination (water, dirt)
- Drastic reduction in maintenance costs; no cleaning of grease needed during bearing inspection
- No grease contamination of equipment, the working area and cooling water
- No misting of oil
- Environmentally friendly; simple disposal methods
- Oil and scale can be individually disposed of (clean separation)

## Function principle air-oil lubrication

An oil pump supplies a progressive or a single-line metering device with oil. The metered quantities of oil from the metering device are supplied to a mixing block that is connected to the compressed air network. The oil droplets in the line to the bearing are pulled apart in streaks by the flow of air. The airflow in the middle of the tube transports the oil along the inner wall of the tube. The carrier compressed air exits the bearing and simultaneously assists in sealing the bearing. No oil mist develops. A continuous, minuscule amount of oil enters the bearing.

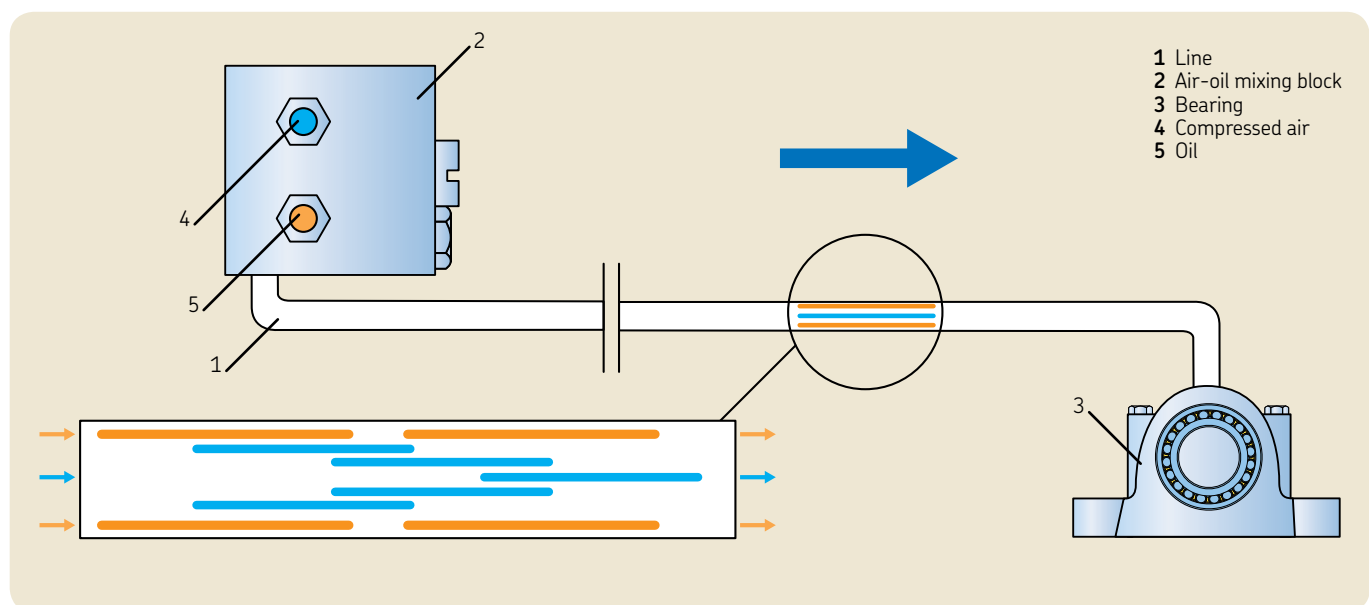

# Air-oil single-line system

The air-oil injector operates on the single-line concept. This means that all injectors are connected via a mainline to the pump. The mainline is alternatively pressurized with oil and vented. Each injector outlet can be individually metered and the function is visually monitored via a steel ball. In addition, the airflow is adjustable for each outlet. As a result, the air-oil injectors are especially suited for systems with lubrication points that have large variances in lubricant requirements per point.

## Environmental information for air-oil system

Air-oil systems, with air-oil injectors and Ecoflow distributors, reduce and accurately meter the lubricant quantities.

- Cleaning and disposal costs are reduced, as grease contamination of equipment, cooling water and the sinter are eliminated.
- When compared to oil mist lubrication, the breathing air is not contaminated with micro oil droplets. The macro oil drops remain in the bearing, thus avoiding breathing air contamination.

## Air-oil mixing injector type AOI-FL

Output quantity: 0,025 to 0,65 cm<sup>3</sup>/stroke  
 With metering screws in increments of: 0,025, 0,05, 0,1, 0,3, 0,4, 0,5, 0,65  
 Oil pressure: max. 50 bar  
 Venting pressure: max. 6 bar  
 Air pressure: 3 to 6 bar  
 Monitoring: visual via steel ball that indicates the stroke of the distributor

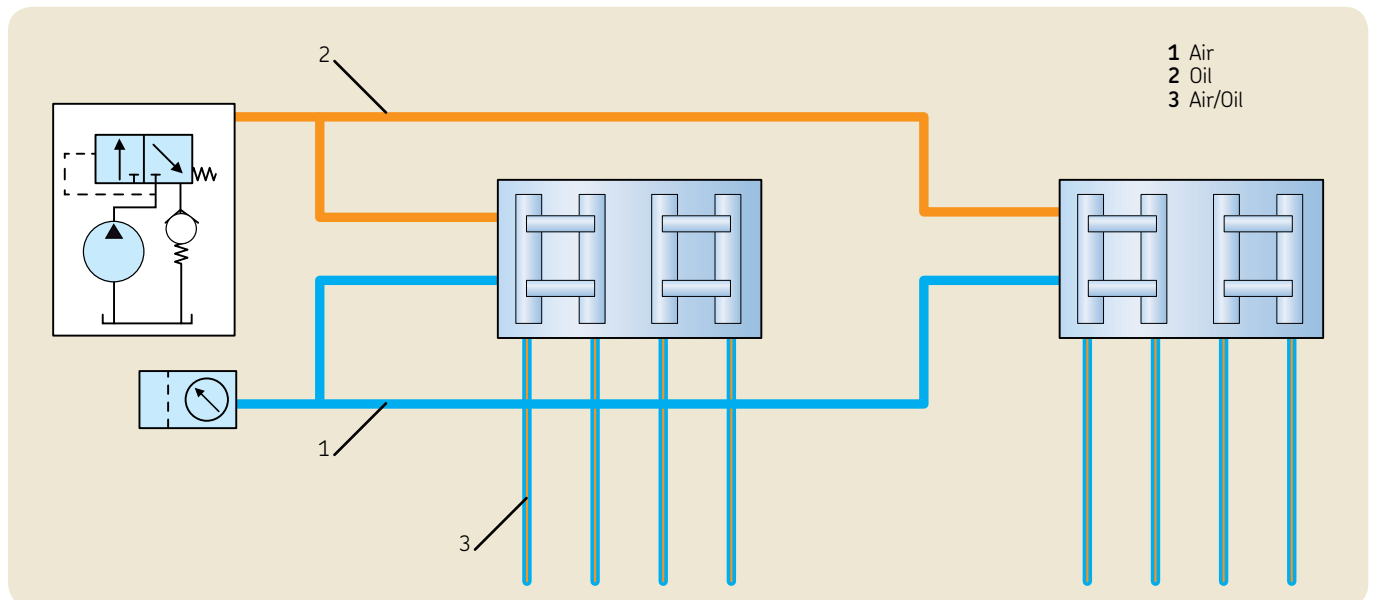
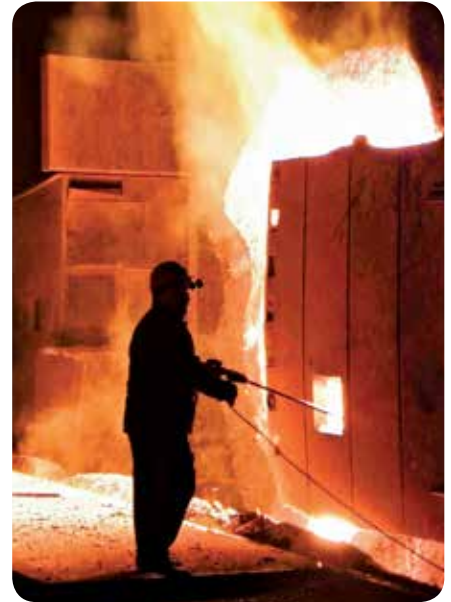

# Air-oil progressive system

When several hundred lubrication points are to be supplied, for example, in continuous casting or roll-out areas, progressive systems with mixing blocks and Ecoflow metering devices are used.

The air-oil mixture is produced within the mixing blocks. The distribution of oil to the mixing blocks occurs via SSV progressive metering devices. Depending on the size of the system, the mixing blocks are available in two different sizes. And, when different size strands are to be lubricated, SSV metering devices may be used for the oil distribution. The air-oil flow is then distributed to the lubrication points by Ecoflow metering devices – which are also available in two sizes: “S” (small), “L” (large).

The large Ecoflow metering devices are used as primary units that supply the smaller metering devices. This reduces the total number of mixing blocks and provides an even distribution for large systems.

Both the mixing blocks and the Ecoflow metering devices do not have moving parts, thus eliminating wear.

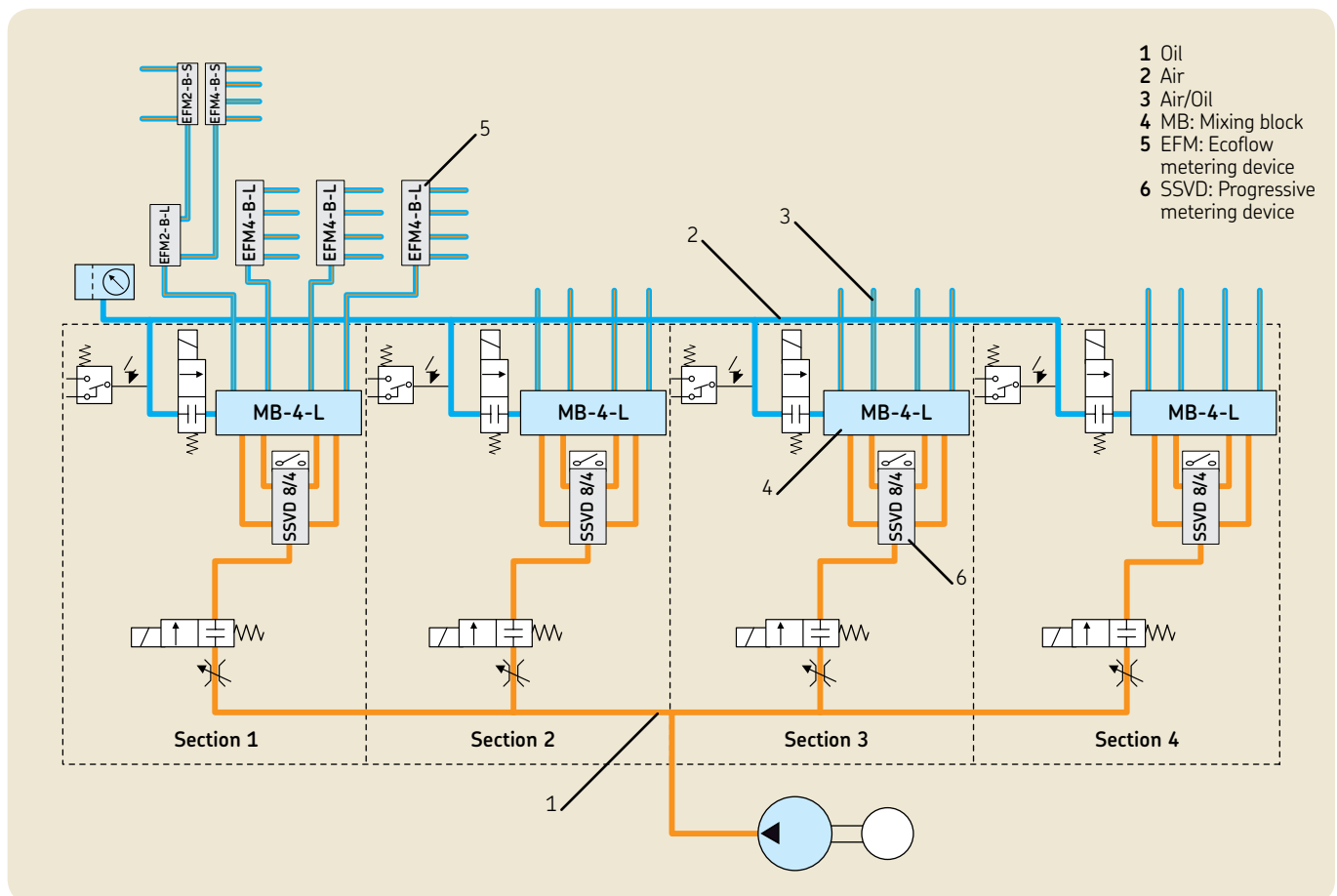
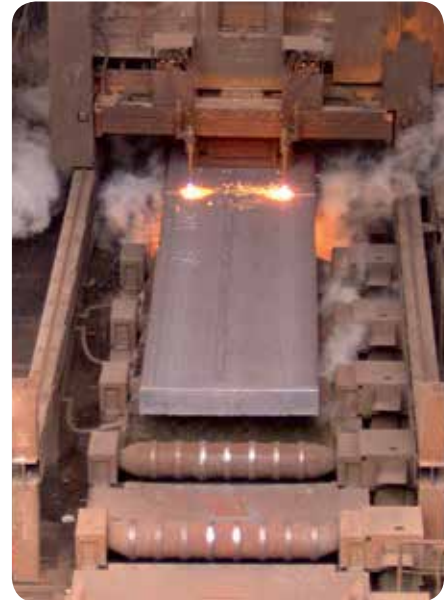

# Air-oil progressive system

## Progressive metering devices SSV and SSVD

### Metering device SSV

The progressive metering device SSV supplies the oil in metered quantities to the mixing blocks. Number of outlets: 6 to 22. Monitoring via piston detector (proximity switch).



*Progressive metering device SSV*

### Metering device SSVD

When vastly differing quantities are required, the SSVD may be used instead of the SSV. The SSVD is adjustable per outlet pair (metering from 0,08 to 1,8 cm<sup>3</sup> in 10 increments). The metering occurs with the metering device block via metering screws.



*Progressive metering device SSVD with metering screws*

### Air-oil mixing block type MB

The air-oil mixing blocks produce the air-oil flow. They are available in 2 sizes: type MB..S and MB..L.

MB..S mixing blocks have 2 to 6 outlets and the MB..L have 2, 3 or 4 outlets. As a result, various size strands with different numbers of lubrication points can be supplied with a flow of air-oil. In accordance with the flow rate, the inlet and outlet port sizes are different.



*Mixing block MB-2-S*

### Mixing block MB

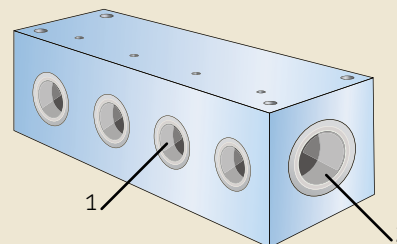

- 1 Air-oil outlet
- 2 Compressed air inlet
- 3 Oil inlet

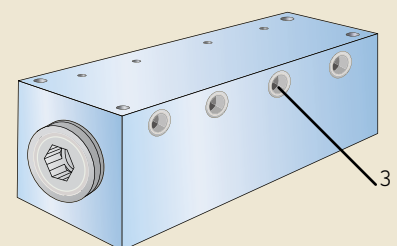

# Air-oil progressive system with Ecoflow air-oil flow metering device

The dividing of the finished air-oil flow is accomplished with the Ecoflow air-oil flow metering device. The special design concept of this device avoids the Coanda Effect\* and achieves the desired split to secondary metering devices or to the lubrication points.

The Ecoflow metering devices are available in 2 sizes "S" (small) and "L" (large):

The large Ecoflow metering devices are used primarily to supply the smaller Ecoflow metering devices.

The large Ecoflow metering devices are available with 2 to 6 outlets, and the small metering devices with 2 to 8 outlets.

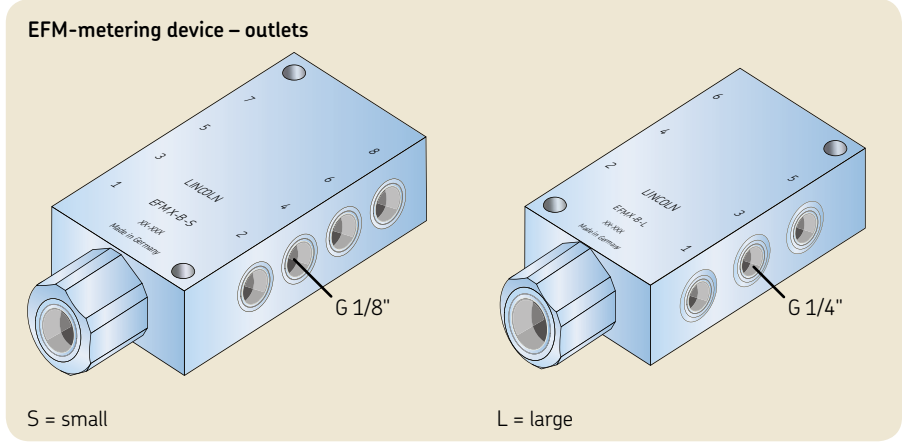
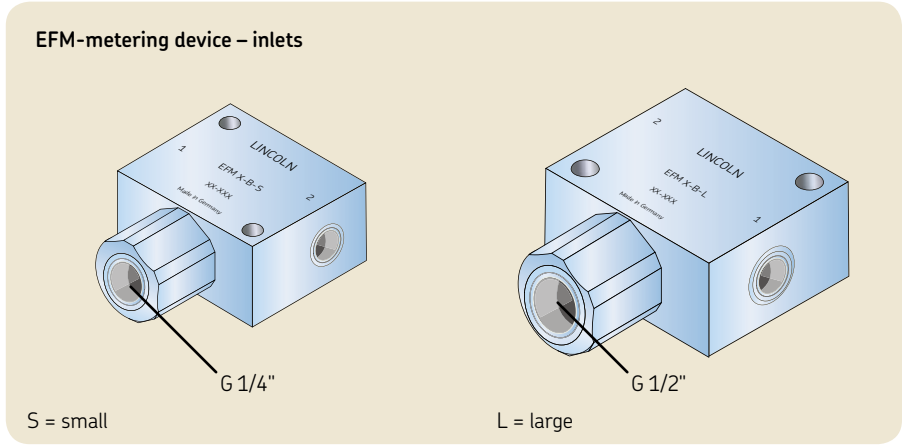
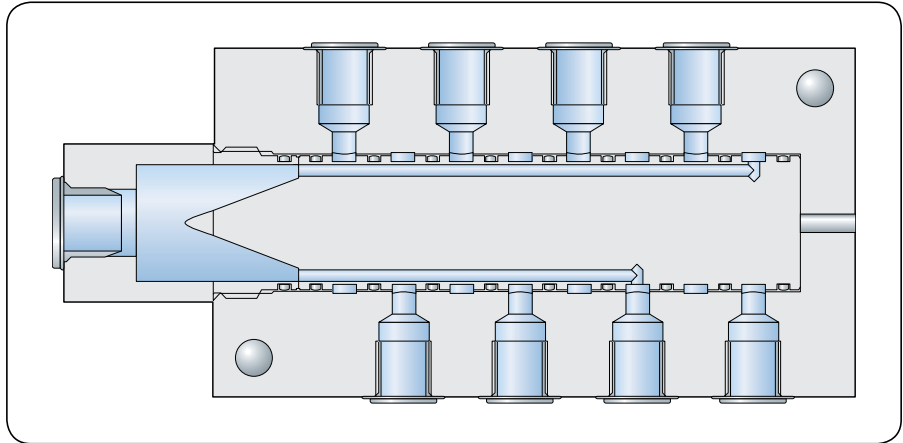

Model	Outlet
EFM 2-B-S	2
EFM 3-B-S	3
EFM 4-B-S	4
EFM 5-B-S	5
EFM 6-B-S	6
EFM 7-B-S	7
EFM 8-B-S	8

Model	Outlet
EFM 2-B-L	2
EFM 3-B-L	3
EFM 4-B-L	4
EFM 5-B-L	5
EFM 6-B-L	6

\*Coanda Effect:  
The tendency of a stream of fluid to stay attached to a convex surface. This results in an undetermined build-up of the oil film on one or more ports.

# Air-oil progressive system

## EFC installation assembly

EFC installation assembly units are used for the lubrication of bearings in rolling mills or straighteners. The EFC supplies 2, 3 or 4 lubrication points from a single inlet with an air-oil flow mixture.

Every assembly consists of a number of installation cartridges and spacers.

The special design of the cartridges enable the air-oil flow to be divided into the desired portions for each connected lubrication point. The spacers are used to match the length of the assembly to that of the bearing.

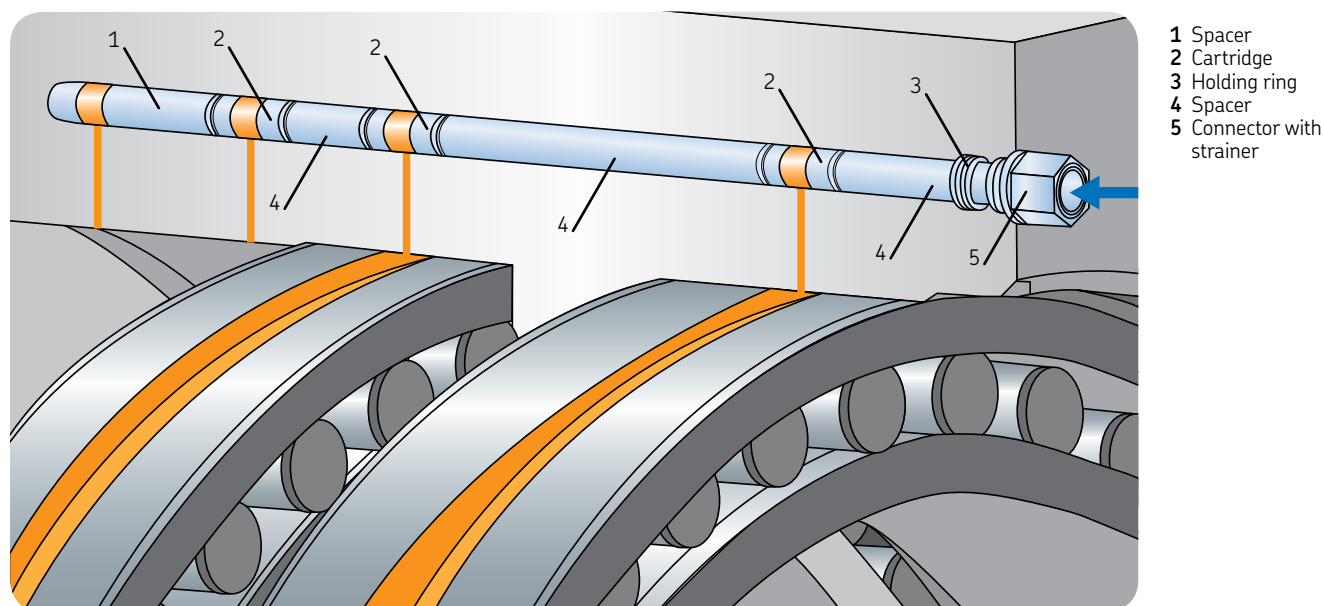

**SKF Lubrication Systems Germany GmbH**

Heinrich-Hertz-Str. 2-8 · 69190 Walldorf · Germany

Tel. +49 (0)6227 33-0 · Fax +49 (0)6227 33-259

© SKF and Lincoln are registered trademarks of the SKF Group.

© SKF Group 2018

The contents of this publication are the copyright of the publisher and may not be reproduced (even extracts) unless prior written permission is granted. Every care has been taken to ensure the accuracy of the information contained in this publication but no liability can be accepted for any loss or damage whether direct, indirect or consequential arising out of the use of the information contained herein.

SKF PUB LS/P2 13237 EN · August 2018 · FORM W-205-EN-1012

Certain image(s) used under license from Shutterstock.com

