

# SKF spherical roller thrust bearings

For long lasting performance





The SKF brand now stands for more than ever before, and means more to you as a valued customer.

While SKF maintains its leadership as a high-quality bearing manufacturer throughout the world, new dimensions in technical advances, product support and services have evolved SKF into a truly solutions-oriented supplier, creating greater value for customers.

These solutions enable customers to improve productivity, not only with breakthrough application-specific products, but also through leading-edge design simulation tools and consultancy services, plant asset efficiency maintenance programmes, and the industry's most advanced supply management techniques.

The SKF brand still stands for the very best in rolling bearings, but it now stands for much more.

**SKF – the knowledge engineering company**

# Contents

## **A Product information**

### **3 Conquer misalignment and heavy axial and radial loads**

3 Where spherical roller thrust bearings are superior

### **4 The strength of SKF spherical roller thrust bearings**

5 Setting new standards with SKF Explorer bearings

### **6 Unrivalled range**

### **8 SKF Explorer spherical roller thrust bearings – for premium performance**

### **10 Where heavy combined loads must be accommodated**

## **B Recommendations**

### **12 Selection of bearing size**

### **14 Design of bearing arrangements**

14 Single direction thrust bearing arrangements

14 Double direction thrust bearing arrangements

16 Axial clearance and preload

18 High-speed bearing arrangements

18 Low-speed bearing arrangements

18 Stiffness

18 Design of associated components

19 Seals

### **20 Typical bearing arrangements**

20 Single direction thrust bearing arrangements

21 Double direction thrust bearing arrangements

### **24 Lubrication and maintenance**

24 Oil lubrication

26 Grease lubrication

28 Maintenance

### **30 Mounting and dismounting**

30 Mounting

31 Dismounting

### **32 Service for a lasting partnership**

## **C Product data**

### **34 Bearing data – general**

### **36 Product table**

## **D Additional information**

### **44 Related SKF products**

### **46 SKF – the knowledge engineering company**

# Conquer misalignment and heavy axial and radial loads

Spherical roller thrust bearings are extremely well suited for heavy-duty applications, with axial loads or combined axial and radial loads. They are self-aligning and can accommodate low as well as high speeds. Due to their design, various degrees of stiffness can be arranged.

Versatility is a characteristic of spherical roller thrust bearings as they can contribute to space saving and cost-effective designs. The following pages provide more detailed explanations about this bearing type and how it can be used.

## Where spherical roller thrust bearings are superior

By design, spherical roller thrust bearings are the only roller thrust bearings that can accommodate radial loads in addition to axial loads. This makes spherical roller thrust bearings an outstanding solution in applications that have to accommodate very heavy axial loads in combination with radial loads. This ability to accommodate combined loads enables economical, space saving designs that can also provide a high degree of stiffness under heavy load conditions. In addition to these unique benefits, spherical roller thrust bearings are also the only roller thrust bearings that can accommodate misalignment and shaft deflections.

Due to the contact angle in spherical roller thrust bearings, they can successfully replace tapered roller bearings in a number of applications.

### Self-aligning

The spherical roller thrust bearing accommodates misalignment between the shaft and housing. This gives smooth, friction-free adjustment under virtually all operating conditions.

### Combined load carrier

The bearing is designed to accommodate very heavy axial loads in one direction or heavy combined axial and radial loads.

### Separable design

The mounting procedure is facilitated, as the bearing can be separated. The shaft washer with the cage and roller assembly and the housing washer can be mounted separately.



# The strength of SKF spherical roller thrust bearings

## Superior bearing service life

Smooth running and long bearing service life are a result of the internal design that gives the raceways and rollers an optimized balance between contact pressure and friction.

SKF spherical roller thrust bearings are well proven in the field and are subject to continuous development to provide improved performance. SKF Explorer performance class bearings are a good example of what can be achieved with purposeful development – in this case, opening up new application horizons.

## Wide speed range

Low internal friction permits the bearings to operate from very low to very high speeds. Speeds up to three times the reference speed are possible by adding certain design features. Basically, the speed performance depends on the bearing arrangement, the application and the operating conditions.

## Robust design

SKF spherical roller thrust bearings are designed for heavy-duty operating conditions and are therefore highly reliable. Made from the unique SKF Xbite heat treated steel, these bearings exhibit excellent wear and fracture toughness characteristics. SKF Xbite heat treated steel also provides high dimensional stability up to 200 °C (390 °F).

## Combined load carrier

Spherical roller thrust bearings can accommodate radial loads up to 55 % of the simultaneously acting axial load. This means that one spherical roller thrust bearing often can be used instead of a combination of a radial and a thrust bearing.

### Benefits

- Compact bearing arrangement
- Reduced arrangement weight
- Reduced arrangement cost

## Self-aligning excellence

Depending on the operating conditions and bearing series, SKF spherical roller thrust bearings can accommodate misalignment of up to 3 degrees between the shaft and housing without adversely affecting bearing performance.

### Benefits

- Insensitive to some shaft misalignment
- Lower operating temperature
- Long bearing service life
- High reliability



## Virtually eliminate edge stresses

High load carrying capability and minimized risk of edge stresses is obtained by an optimal relationship between the rollers and the raceways.

### Benefits

- Long bearing service life
- High reliability

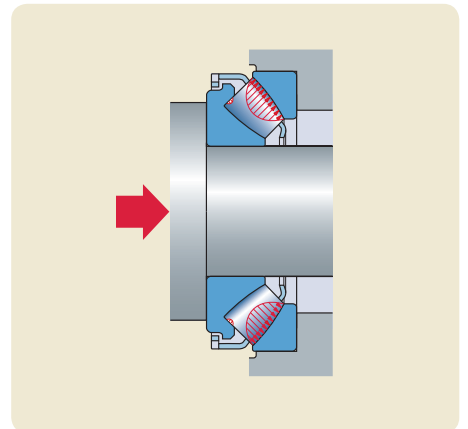
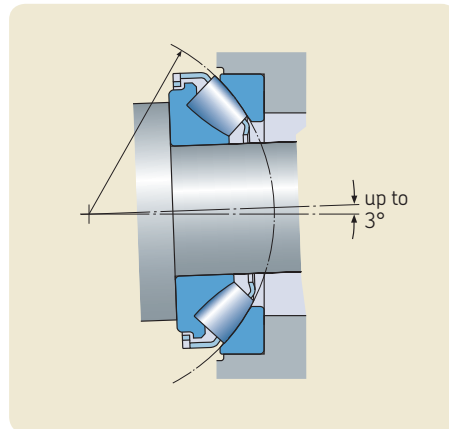
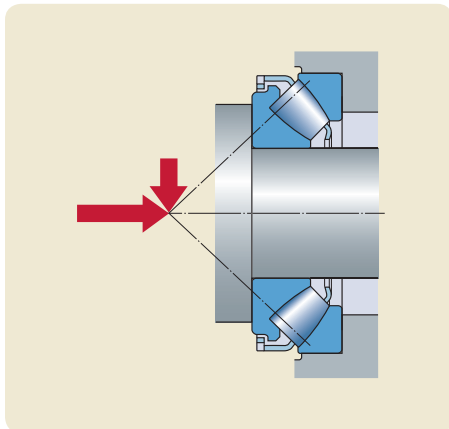

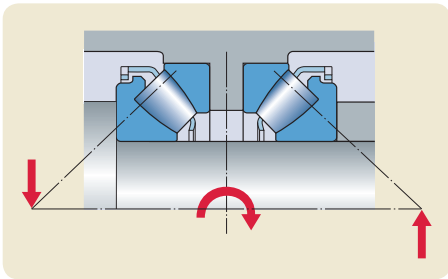

**When stiffness counts**

By design, spherical roller thrust bearings provide a high degree of stiffness. In addition, high moment stiffness can be achieved when two spherical roller thrust bearings are mounted in a back-to-back arrangement. This is due to the long distance between the pressure centres, where the loads are acting.

**Benefits**

- Minimal bearing arrangement deformation under radial and axial loads
- Minimal bearing arrangement deflection under moment loads
- Compact design

**Cool running at high speeds ...**

Specially designed spherical roller end/flange contacts reduce stress levels and optimize lubricant film formation. This reduces friction enabling bearings to run cooler even in high-speed applications.

**... and exceptionally low friction at low speeds**

The favourable roller end/flange contact is also very beneficial for low speed performance.

**Benefits**

- High machine output
- High reliability
- Minimized maintenance cost
- Reduced energy consumption

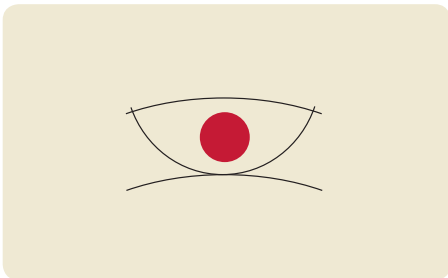

**Heavy-duty performance cages**

SKF spherical roller thrust bearings are designed for heavy-duty conditions. The robust metallic cages have been designed to take full advantage of the lubricant in the sliding contacts even under poor lubrication conditions.

**Benefits**

- Suitable for high as well as low speed applications
- Accommodate high temperatures

**High operational reliability**

High operational reliability is a prerequisite for long and trouble-free service life. This is why reliability is one of the cornerstones of the SKF design philosophy. A recent example of this is the SKF Explorer spherical roller thrust bearing, which is stronger and more reliable than any other spherical roller thrust bearing on the market.

**Benefits**

- Longer service life
- Lower maintenance cost
- More machine uptime

**Setting high standards with SKF Explorer bearings**

SKF Explorer spherical roller thrust bearings are the result of an intensive effort by an international team of SKF scientists and engineers. The result is a new performance class for SKF spherical roller thrust bearings that provides significantly longer service life and smoother running.

Spherical roller thrust bearings belonging to the SKF Explorer performance class have their designation printed in blue in the product table.

**• Steel**

Improved, ultra-clean steel provides longer bearing service life, even under heavier loads.

**• Heat treatment**

A unique SKF heat treatment process significantly improves wear-resistance and fracture toughness.

**• Manufacturing**

Refined precision manufacturing processes allow the production of bearings that run smoother and maximize the effects of the lubricant between the contacting surfaces.

**• Internal geometry**

A fine-tuned micro-geometry of the rolling contacts provides better load distribution and reduced friction.

SKF Explorer spherical roller thrust bearings provide higher performance for the same size as explained in more detail starting on **page 8**.



# Unrivalled range

The standard range of SKF spherical roller thrust bearings starts from a 60 mm bore diameter and goes up to a 1 600 mm bore. Larger sizes can be supplied on request.

## Three bearing series for a wide range of applications

The standard bearings cover an extensive dimension range in the three ISO Dimension Series 292, 293 and 294. They satisfy the important selection criteria

- load carrying capacity
- rotational speed
- space in the application.

When very high load carrying capacity is required, bearings in the 293 and 294 series are suitable. The small cross section of the 292 series bearings have favourable speed, space and weight characteristics.

Smaller and more cost-effective equipment can be designed for longer bearing service life or higher output as a result of the high combined load carrying capacity of SKF spherical roller thrust bearings.

These bearings can operate at high speeds even under heavy load conditions.

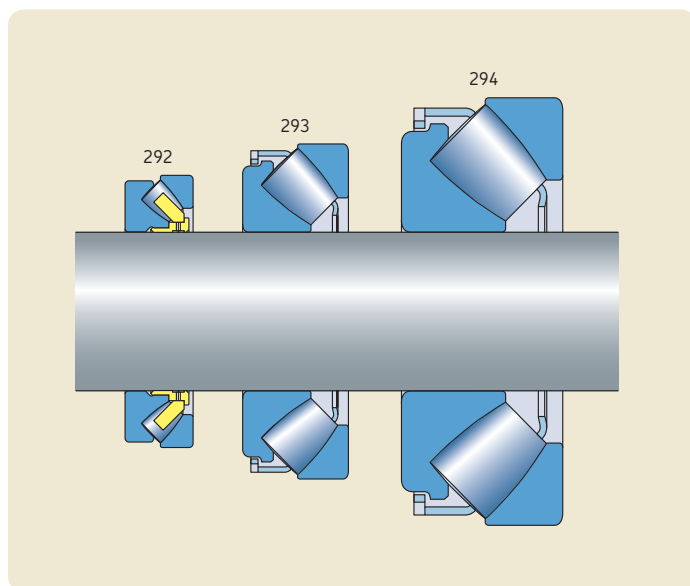

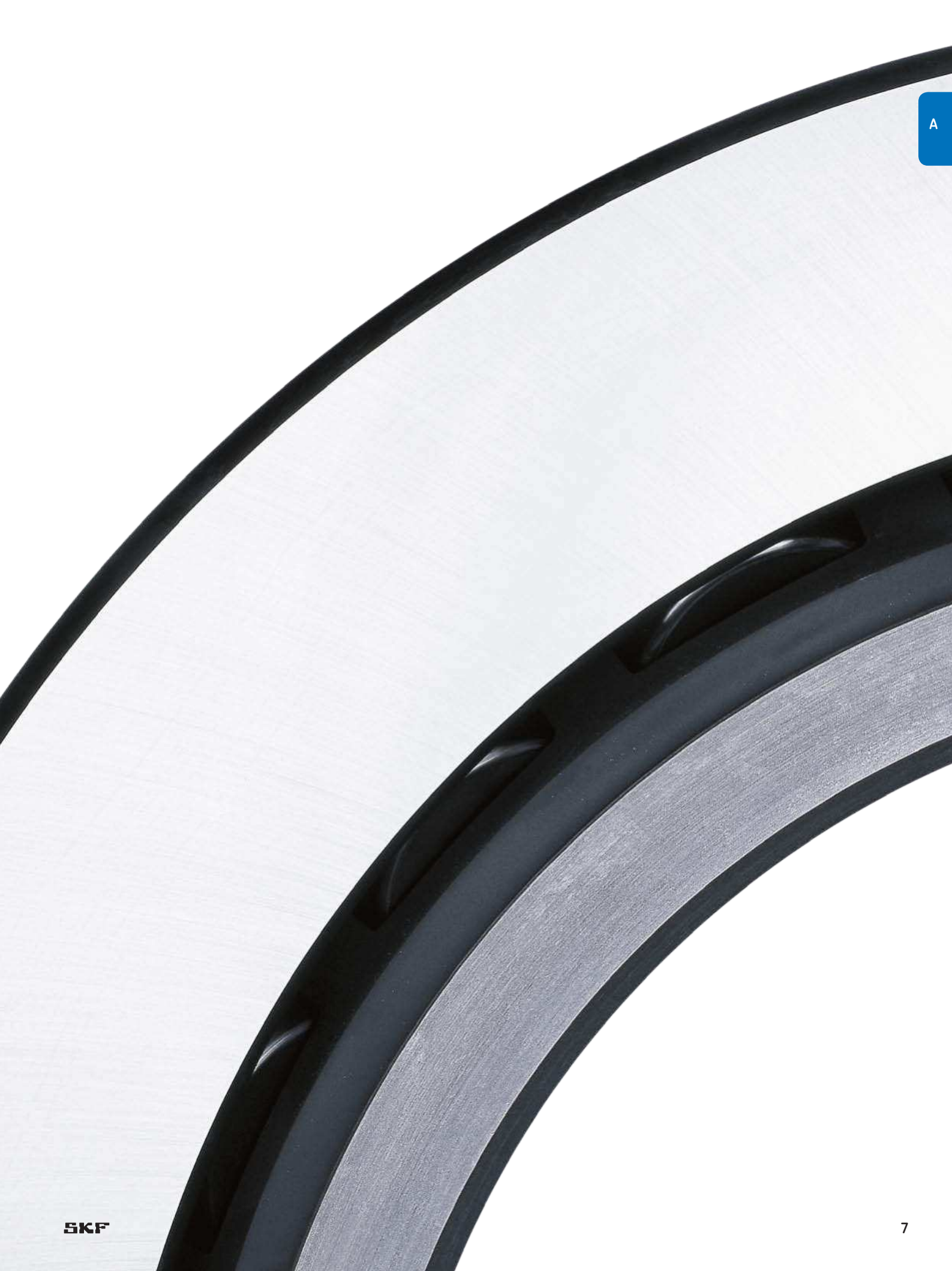

# SKF Explorer spherical roller thrust bearings – for premium performance

Having invented the spherical roller thrust bearing some sixty years ago, SKF has been the leading manufacturer of these bearings ever since.

Now, SKF specialists in different disciplines have combined their experience and know-how resulting in a large step forward in bearing technology.

We are proud of having made tomorrow's bearing technology available for our customers today. SKF Explorer bearings represent a significant breakthrough in performance. By studying the interrelationship between each bearing component, SKF scientists were able to maximize the effects of internal load distribution and lubrication and minimize the effects of friction, wear, and contamination.

The SKF Explorer performance class is the result of years of intensive research by an international team of SKF scientists and engineers. It incorporates a number of improvements.

- **Improved material**

The improved steel used in SKF Explorer bearings is extraordinarily clean and homogeneous. It forms an excellent structure that contributes to an optimum stress distribution in the material.

- **The unique SKF heat treatment process**

To take advantage of the improved steel used for SKF Explorer bearings, SKF has developed a unique heat treatment process to improve the bearing's resistance to wear while retaining the temperature resistance and toughness of the bearing.

- **New precision manufacturing processes**

Improved manufacturing processes have enabled SKF to provide closer tolerances for all essential bearing parameters. In addition, SKF Explorer bearings have an improved surface texture to maintain an optimum oil film between the contact surfaces.

- **New bearing knowledge**

Sophisticated in-house software has enabled SKF design engineers to study internal bearing dynamics to an extent not previously possible. This has led the way to design refinements that have been implemented in SKF Explorer bearings, enabling further optimization of the rolling element/raceway contacts.





## The result: longer bearing service life

All these improvements contribute to a significant increase in bearing service life and reliability. This can best be shown through a calculation using the SKF rating life equation. The properties of SKF Explorer spherical roller thrust bearings are taken into consideration by

- increased basic dynamic load ratings and
- better resistance to contamination, resulting in an increased life modification factor  $a_{SKF}$ .

## Availability

The popular small and medium size spherical roller thrust bearings in the 293 and 294 series are available as SKF Explorer bearings.

In the product table, the SKF Explorer bearing designations are printed in blue.

## Product designations

SKF Explorer bearings have retained the designations of the earlier standard bearings, e.g. 29330 E. However, each bearing and its box are marked with the name "SKF EXPLORER".

*The excellent performance of SKF Explorer spherical roller thrust bearings can be exploited in different ways depending on the application requirements*

### Increase service life of existing designs

Replace the existing bearing with an SKF Explorer bearing of equal size to

- increase life
- increase machine uptime
- increase safety factor
- reduce maintenance costs.

### Maintain power output of new designs

Use a smaller SKF Explorer bearing to

- reduce overall machine dimensions to save on material costs and weight
- increase speeds
- achieve smoother, quieter operation
- reduce friction and energy consumption
- reduce lubricant usage.

### Increase power output of existing designs

Replace the existing bearing with an SKF Explorer bearing of equal size, maintaining machine uptime to

- increase power density (output)
- increase loads
- avoid costly redesign.

### Increase power density of new designs

Use a lower cross section SKF Explorer bearing with the same outside diameter to

- use a stronger or even hollow shaft
- achieve a stiffer and more cost-effective design
- increase system life due to higher stiffness.

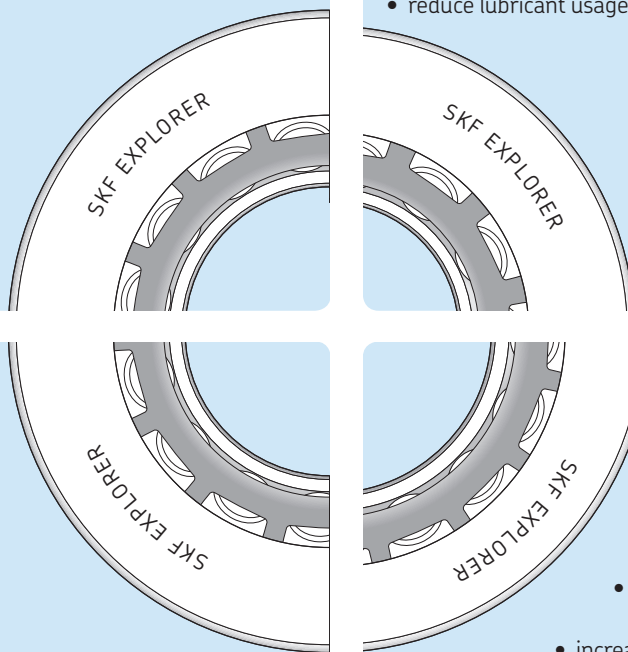

# Where heavy combined loads must be accommodated

Long service life, high reliability, reduced maintenance and the ability to down-size are all features of SKF Explorer spherical roller thrust bearings.

In addition, the ability to accommodate very heavy axial loads or heavy combined loads make SKF spherical roller thrust bearings indispensable in many applications.

SKF spherical roller thrust bearings are frequently used in the industries listed below. Other applications include bridges, cranes, wind turbines, hydraulic and electric motors, and robots.

## Industries

- Metalworking
- Plastics
- Marine
- Industrial gearboxes
- Pulp & paper
- Material handling
- Fluid machinery
- Mining & construction

## Requirements

- Reliability
- Long service life
- High load carrying capacity
- Insensitivity to misalignment
- Minimal maintenance
- Reduced operating costs
- Technical support

## Solution





© Great Lakes Group, Cleveland, Ohio



# Selection of bearing size

## Bearing life

The life-extending improvements embodied in SKF Explorer spherical roller thrust bearings can best be understood using the SKF rating life method. This method constitutes an extension of the fatigue life theory developed by Lundberg and Palmgren and is better able to predict bearing life. The SKF rating life method was first presented in 1989. For roller bearings

$$L_{nm} = a_1 a_{SKF} L_{10}$$

or

$$L_{nm} = a_1 a_{SKF} \left( \frac{C}{P} \right)^{10/3}$$

If the speed is constant, it is often preferable to calculate the life expressed in operating hours using

$$L_{nmh} = a_1 a_{SKF} \frac{1\,000\,000}{60 n} \left( \frac{C}{P} \right)^{10/3}$$

where

$L_{nm}$  = SKF rating life (at 100 –  $n^1$ ) % reliability), millions of revolutions

$L_{nmh}$  = SKF rating life (at 100 –  $n^1$ ) % reliability), operating hours

$L_{10}$  = basic rating life (at 90 % reliability), millions of revolutions

$a_1$  = life adjustment factor for reliability (→ **table 1**)

$a_{SKF}$  = SKF life modification factor (→ **diagram 1**)

$C$  = basic dynamic load rating, kN

$P$  = equivalent dynamic bearing load, kN

$n$  = rotational speed, r/min

## The $a_{SKF}$ factor

The  $a_{SKF}$  factor represents a very complex relationship between load, contamination and lubrication. Values for  $a_{SKF}$  can be obtained from **diagram 1** for different values of  $\eta_c$  ( $P_u/P$ ) and  $\kappa$ , where

$\eta_c$  = factor for contamination level

$P_u$  = bearing fatigue load limit

$P$  = equivalent dynamic bearing load

$\kappa$  = lubricant viscosity ratio

**Diagram 1** is valid for lubricants without EP additives. For non-SKF Explorer spherical roller thrust bearings, the values in black colour on the x axis should be used. For SKF Explorer bearings, the values in blue should be used. For SKF Explorer spherical roller thrust bearings it has been found appropriate to multiply  $\eta_c$  ( $P_u/P$ ) by a factor of 1,4 as an expression of the life extending refinements of these bearings, and the blue values correspond to this.

Detailed information is provided in the SKF General Catalogue and the SKF Interactive Engineering Catalogue online at [www.skf.com](http://www.skf.com).

## Equivalent dynamic bearing load

Normally a spherical roller thrust bearing is arranged so that runouts in the bearing arrangement do not affect the load distribution in the bearing. For dynamically loaded spherical roller thrust bearings arranged under these conditions, provided  $F_r \leq 0,55 F_a$

$$P = 0,88 (F_a + 1,2 F_r)$$

When runouts in the bearing arrangement affect the load distribution in the spherical roller thrust bearing, provided  $F_r \leq 0,55 F_a$

$$P = F_a + 1,2 F_r$$

If  $F_r > 0,55 F_a$ , contact the SKF application engineering service.

## Equivalent static bearing load

For statically loaded spherical roller thrust bearings, provided  $F_r \leq 0,55 F_a$ ,

$$P_0 = F_a + 2,7 F_r$$

If  $F_r > 0,55 F_a$ , contact the SKF application engineering service.

## Bearing arrangements with axial loads acting in both directions

The information above is valid for single bearings but when the thrust load changes direction, it is necessary to use two bearings, most often two spherical roller thrust bearings mounted in a back-to-back or face-to-face arrangement. In some cases the radial load is accommodated by a separate radial bearing and the spherical roller thrust bearings are radially free and spring preloaded (→ **fig. 4, page 15**) to provide that the bearing that is axially unloaded is subjected to the minimum requisite thrust load (→ section "Bearing data – general", starting on **page 34**).

In such cases the equivalent bearing load is calculated for each bearing separately as for single bearings. The life of the pair is then calculated as a system life.

Reliability %	Failure probability n %	SKF rating life $L_{nm}$	Factor $a_1$
90	10	$L_{10m}$	1
95	5	$L_{5m}$	0,62
96	4	$L_{4m}$	0,53
97	3	$L_{3m}$	0,44
98	2	$L_{2m}$	0,33
99	1	$L_{1m}$	0,21

<sup>1)</sup> The factor n represents the failure probability, i.e. the difference between the requisite reliability and 100 %

## Radial loads

Because the raceways are at an angle to the bearing axis, an axial force is induced when a spherical roller thrust bearing is subjected to a radial load.

In cases where the bearings are radially located and subjected to combined loads with  $F_r > 0,55 F_a$ , this internal axial load must be considered when the equivalent load is calculated for each of the bearings.

To calculate the equivalent load in such cases, contact the SKF application engineering service.

## SKF Explorer bearings versus earlier SKF bearings – a comparison

The performance enhancements incorporated in SKF Explorer spherical roller thrust bearings can best be demonstrated by a life calculation comparison.

### Example

The operating conditions for a 29332 E bearing in its earlier standard version and the new SKF Explorer version are

- equivalent dynamic bearing load  $P = 126 \text{ kN}$
- viscosity ratio  $\kappa = 2$
- contamination factor  $\eta_c = 0,4$ .

### Catalogue data:

- Earlier standard bearing
  - a basic dynamic load rating  $C = 1\ 010 \text{ kN}$
  - a fatigue load limit  $P_u = 375 \text{ kN}$
- SKF Explorer bearing
  - a basic dynamic load rating  $C = 1\ 180 \text{ kN}$
  - a fatigue load limit  $P_u = 375 \text{ kN}$

The life of each bearing is then calculated.

### Earlier standard bearing

For  $\eta_c (P_u/P) = 0,4 (375/126) = 1,2$  and using the black values on the x axis in **diagram 1** and  $\kappa = 2$

$$a_{SKF} = 3,0$$

so that the life becomes

$$L_{10m} = a_{SKF} (C/P)^{10/3} = 3,0 (1\ 010/126)^{10/3}$$

$$L_{10m} = 3\ 090 \text{ millions of revolutions}$$

### SKF Explorer bearing

For  $\eta_c (P_u/P) = 0,4 (375/126) = 1,2$  using the blue values on the x axis in **diagram 1** and  $\kappa = 2$ .

$$a_{SKF} = 5,5$$

so that the life becomes

$$L_{10m} = a_{SKF} (C/P)^{10/3} = 5,5 (1\ 180/126)^{10/3}$$

$$L_{10m} = 9\ 520 \text{ millions of revolutions}$$

In this case, the life of the SKF Explorer bearing compared with that of the earlier standard bearing is  $9\ 520/3\ 090 = 3,08$  or three times longer.

Diagram 1

Factor  $a_{SKF}$  for spherical roller thrust bearings

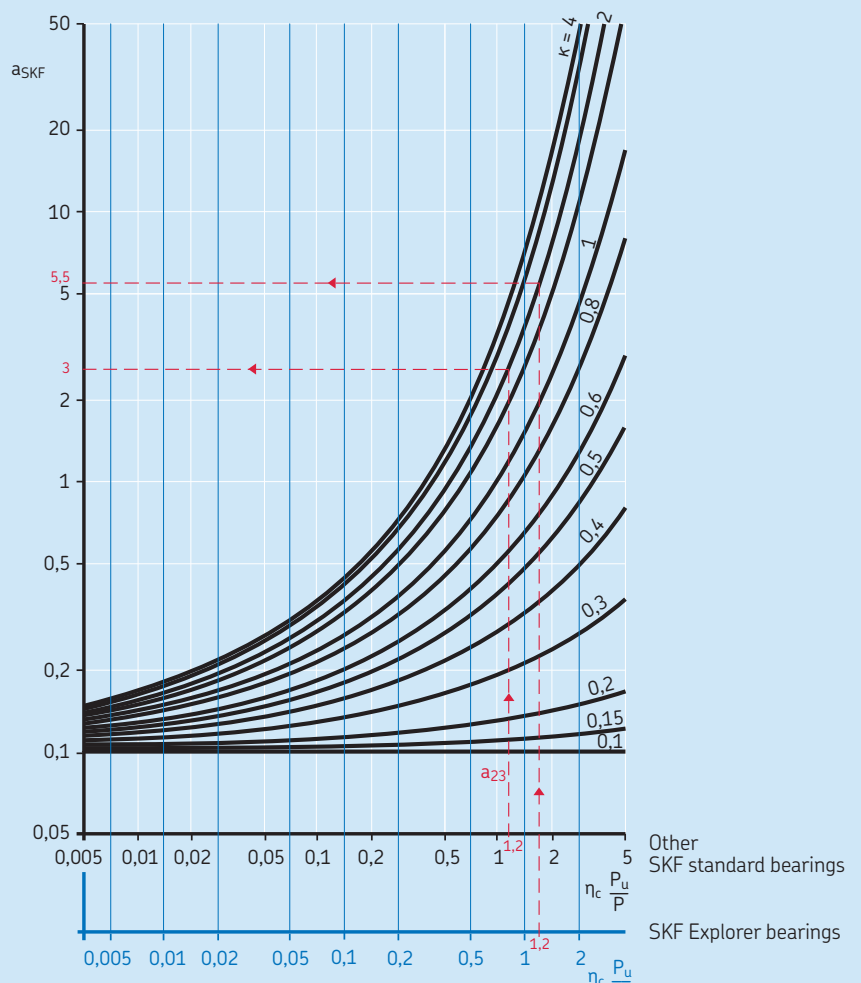

If  $\kappa > 4$ , use curve for  $\kappa = 4$   
As the value of  $\eta_c (P_u/P)$  tends to zero,  $a_{SKF}$  tends to 0,1 for all values of  $\kappa$

# Design of bearing arrangements

## Single direction thrust bearing arrangements

A single spherical roller thrust bearing can support a shaft together with a radial bearing when

- the thrust load is in one direction only, and
- the total axial load on the bearing is never lower than the requisite minimum axial load (→ page 35).

The spherical roller thrust bearing locates the shaft radially and axially in one direction (→ fig. 1). A radial bearing provides radial location at the other end.

In cases where the shaft is supported by two radial bearings, the spherical roller thrust bearing must be radially free. If the axial load can drop below the requisite minimum load, the spherical roller thrust bearing should be spring preloaded (→ fig. 2).

For very heavy axial loads, a tandem arrangement can be used to distribute the load over the bearings (→ fig. 7, page 22).

## Double direction thrust bearing arrangements

Spherical roller thrust bearings mounted in pairs for thrust loads acting in both directions can be mounted in a face-to-face or back-to-back arrangement to eliminate the need for a radial bearing. By eliminating the radial

bearing, any fretting and rubbing normally associated with conflicts between the radial bearing and thrust bearing are avoided.

### Without spring preloading

SKF spherical roller thrust bearings operating at moderate speeds can be mounted in pairs to locate the shaft both axially and radially without any axial spring preloading.

Like tapered roller bearings, SKF spherical roller thrust bearings can be mounted with an interference fit in the housing to avoid fretting corrosion that otherwise would lead to wear.

Values for permissible axial clearance are provided in the section "Axial clearance and preload", starting on page 16.

Double direction spherical roller thrust bearing arrangements with axial clearance should incorporate an internal design feature indicated by the designation suffix VU029.

### With spring preloading

SKF spherical roller thrust bearings operating at high speeds should be spring preloaded to secure the requisite minimum load and avoid smearing (→ fig. 3).

Spring preloaded arrangements can be either radially locating or radially free.

When the thrust bearing arrangement is radially free, another bearing must be used for radial location. The thrust bearing housing washers must then be fitted with adequate

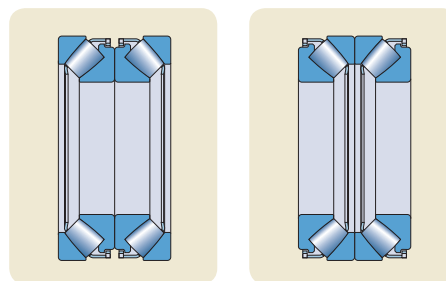

Face-to-face arrangement

Back-to-back arrangement

radial clearance so that radial load cannot act on the thrust bearings (→ fig. 3).

For the permissible misalignment of a few milliradians, the following rules can be applied

- radial clearance  $\Delta_h \geq 0,5 \text{ mm}$  when  $D \leq 250 \text{ mm}$
- radial clearance  $\Delta_h \geq 0,002 D$  when  $D > 250 \text{ mm}$ .

If the maximum misalignment angle is known, then the required minimum radial clearance in the housing for each thrust bearing (→ fig. 4) can be more precisely obtained from

$$\Delta_h > 2 L_1 \sin \gamma_s + \Delta_{oc}$$

$$\Delta_h > 2 L_2 \sin \gamma_s + \Delta_{oc}$$

**Double direction spring preloaded thrust bearing arrangement – the spherical roller thrust bearings are radially free**

Single direction thrust bearing arrangement for combined loads with a single spherical roller thrust bearing

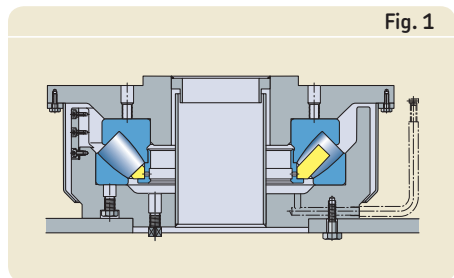

Fig. 1

Single direction thrust arrangement with single spring preloaded spherical roller thrust bearing and two radial bearings

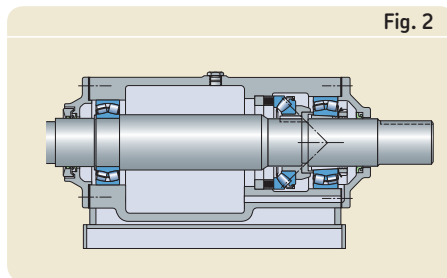

Fig. 2

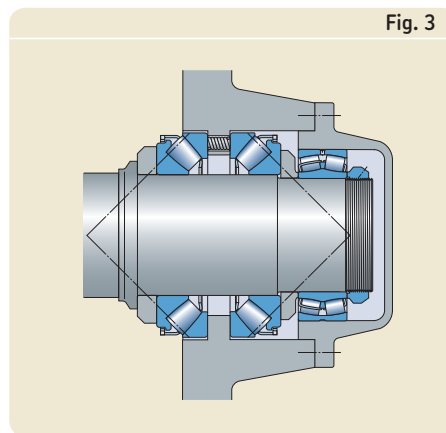
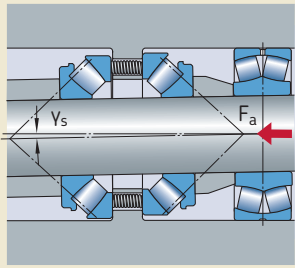
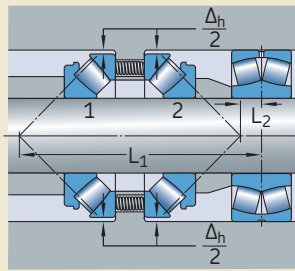

Fig. 3

Fig. 4



Double direction, spring preloaded spherical roller thrust bearing arrangement, radially free

where

$\Delta_h$  = minimum radial clearance between the bearing and housing, mm

$L_1$  = distance between the centre of the radial bearing and the pressure centre of the thrust bearing 1, mm

$L_2$  = distance between the centre of the radial bearing and the pressure centre of the thrust bearing 2, mm

$\gamma_s$  = angular misalignment of shaft, rad

$\Delta_{oc}$  = the sum of the radial internal clearance and the housing clearance fit of the radial bearing, mm

### Spring preloading with a radially locating and a radially free bearing

Arrangements where the axially loaded bearing is radially located and the other is radially free are frequently used (→ fig. 5).

A radially free opposing spherical roller thrust bearing can accommodate a high degree of misalignment, making it possible to utilize the paired arrangement's self-aligning features.

As the housing washer is supported by springs, it will tilt but there will be no sliding or rubbing motion between the washer and housing. However, it is important that the radial clearance in the housing is adequate

Fig. 5

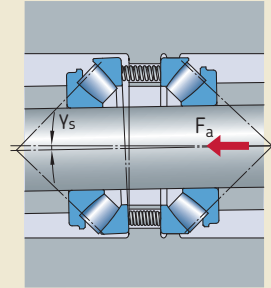
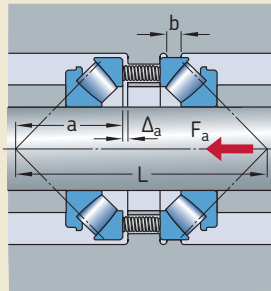

Double direction, spring preloaded spherical roller thrust bearing arrangement with one bearing radially free and the other carrying the radial load

so that the washer does not make contact with the housing. If the axial clearance  $\Delta_a$  in the housing is known, the permissible misalignment will be

$$\gamma_s = \frac{2 \Delta_a a}{L D}$$

where

$\gamma_s$  = angular misalignment of the shaft, rad

$\Delta_a$  = housing axial clearance, mm

$a$  = distance between the pressure centre and housing washer face of the unloaded bearing, mm

$L$  = distance between the pressure centres of the bearings, mm

$D$  = housing washer outside diameter, mm

The above equation is valid for both back-to-back and face-to-face bearing arrangements. To determine the necessary clearance, the above formula for  $\Delta_h$  can be used when omitting  $\Delta_{oc}$ .

### Spring preloading when both bearings are radially located

If both bearings are radially locating, then a good conflict-free centring of the shaft

Fig. 6

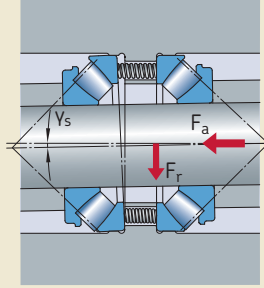
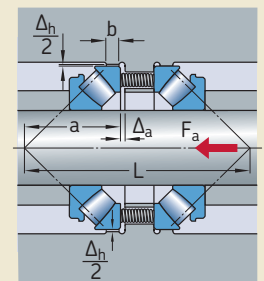

Double direction, spring preloaded spherical roller thrust bearing arrangement where both bearings can carry the radial load

is achieved because the axially loaded bearing also accommodates the radial load (→ fig. 6).

If the axial and radial clearances are chosen in accordance with the following rules, this arrangement will accommodate misalignment without increasing bearing loads.

In this case, the necessary radial movement of the least loaded bearing can be accomplished by the tilting of the housing washer rather than radial movement in the housing.

The requisite axial clearance for a particular shaft misalignment is calculated as follows

$$\Delta_a = \frac{\gamma_s L D}{2 a}$$

The corresponding requisite radial housing clearance is

$$\Delta_h = \frac{\gamma_s L}{a} \left( \frac{\gamma_s L D}{2 a} + b \right)$$

where

$b$  = width of radial support, mm

# Axial clearance and preload

Depending on the application, the spherical roller thrust bearings in an arrangement can have an operational axial clearance or preload.

When a vertical application incorporates a single spherical roller thrust bearing, the load from the mass of the shaft acts as a preload on the spherical roller thrust bearing to locate the shaft radially and axially in one direction (→ fig. 1, page 14).

The radial bearing at the other end of the shaft must have a certain axial freedom to be able to accommodate thermal expansion and contraction of the shaft.

In applications where the shaft is supported by two radial bearings, the spherical roller thrust bearing must be mounted radially free. If the thrust load can drop below the requisite minimum load, the bearing should be spring preloaded (→ fig. 2, page 14).

## Axial clearance

Since a spherical roller thrust bearing is separable, the axial clearance can only be obtained after mounting and is determined by adjusting the bearing against a second bearing that provides location in the other direction.

### Double direction thrust bearing arrangements with two spherical roller thrust bearings on a horizontal or vertical shaft

For bearing arrangements without spring loading and operating under moderate speeds, recommendations for the maximum axial internal clearance in relation to bearing height after mounting are shown in **table 1**.

### Clearance changes due to temperature differences

Generally, the shaft and shaft washers have a higher operating temperature than the housing and housing washers. This temperature difference influences the bearing operating clearance.

For a face-to-face arrangement, the radial as well as the axial expansion will reduce bearing clearance.

For a back-to-back arrangement, radial expansion will reduce the clearance while axial expansion will increase the clearance in the bearing. By choosing a specific bearing distance, the radial and axial thermal expansion can cancel each other out so that the clearance will not be affected significantly.

Table 1

Series	$\Delta_a/H^{1)}$	
	Horizontal shaft	Vertical shaft
		Unloaded housing washer <sup>2)</sup> – face down
		Unloaded housing washer – face up
292	0,0012	0,0022
293	0,0010	0,0026
294	0,0026	0,0038
		0
		0,0001
		0,0004

<sup>1)</sup>  $\Delta_a$  = residual axial clearance after mounting, mm  
H = height of one bearing, mm  
<sup>2)</sup> If  $F_r > 0,64 F_a$ , the rules for unloaded housing washer face up apply, if the shaft is vertical. However, the listed values are to be multiplied by a factor of two since, under radial loading, the clearance is shared equally by the bearings. With an arrangement design described in the section "Bearing arrangement with a spherical roller thrust bearing combined with a thrust ball bearing" (→ fig. 9, page 23), the listed values under Vertical shaft – face down are valid.

**Recommendations for maximum axial clearance in relation to the bearing height for double direction thrust bearing arrangements without spring preloading – two spherical roller thrust bearings on a horizontal or a vertical shaft**

## Axial preload

In some applications, an axial preload is used to enhance the stiffness of the bearing arrangement, improve the accuracy of the shaft guidance or increase the service life of the bearings. In other applications, the preload is used to safeguard the minimum load prerequisite to avoid bearing damage caused by sliding of the rollers on the raceways.

### Determining preload

Preload is expressed either as a force or as a displacement.

Empirical values for the optimum preload force can be obtained from proven designs and can be applied to similar designs. For new designs, however, SKF recommends calculating the preload force and, when possible, verifying the calculations by testing. The reliability of the calculation depends on how well the assumptions made about the temperature conditions in operation and the elastic behaviour of the associated components, especially the housing, coincide with the actual conditions.

When determining the mounting preload, the operational preload force required for an optimum combination of stiffness, bearing service life and reliability must be calculated first. Then the cold mounting preload can be calculated. The appropriate preload at operating temperature depends on the bearing load. For a spherical roller thrust bearing exposed

to a radial load, a force acting in the axial direction will be induced in the bearing. This force must be accommodated by another bearing facing in the opposite direction. This load must be considered when the preload force is calculated (→ section "Radial loads" on page 13).

For spring preloaded spherical roller thrust bearings, the total spring force and any loads from the mass of a vertical shaft need to be identified so that the load on the bearing is always equal to or larger than the requisite minimum axial load. Four springs can be used for smaller bearings but the number must be increased for larger bearings to provide proper support and prevent deformation of the housing washer.

To determine the appropriate value of the preload force and the number of springs for spring preloading, contact the SKF application engineering service.



## Setting clearance and preload

In face-to-face arrangements, the clearance and preload is set by adjusting the housing washers, which in most cases have a clearance fit and are therefore easy to move. The required position is obtained by placing shims between the housing and cover.

For back-to-back arrangements, the shaft washer, which generally has an interference fit, can be difficult to move into position. Here, use of the SKF oil injection method can facilitate the adjustment.

In case of preload, the oil injection method, in combination with an HMV .. E type SKF hydraulic nut, can be used (→ **fig. 7**). When the washer has been heat mounted close to its correct position, the preload force is applied to the shaft washer by means of a specific oil pressure in the hydraulic nut, while oil is injected between the washer and shaft. This pushes the washer into the correct position. The preload from the hydraulic nut must be maintained until the oil injection pressure has been released and the washer has obtained a full interference fit with the shaft.

However, to use the oil injection method, the shaft needs to be prepared with the necessary ducts and grooves (→ section "Dismounting", starting on **page 30**).

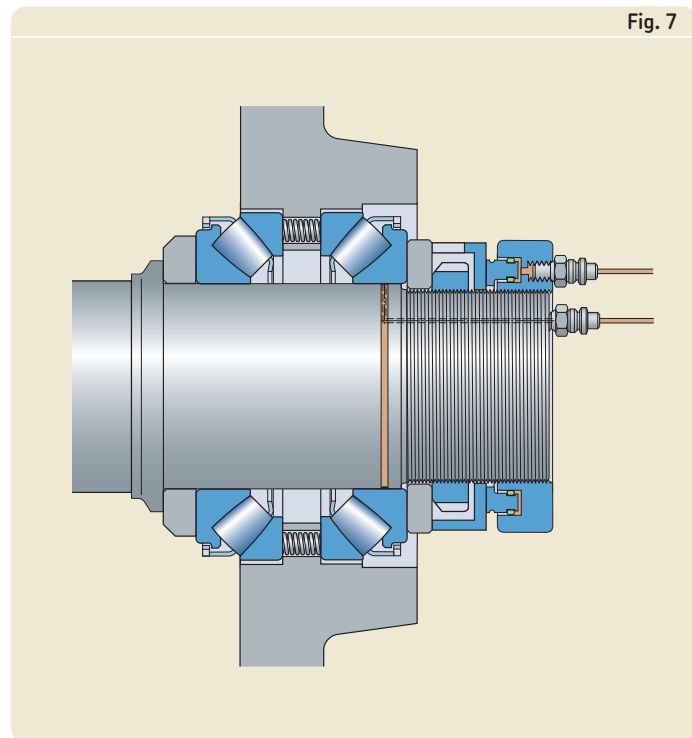

*Setting the required preload using the oil injection method and an SKF hydraulic nut*

## High-speed bearing arrangements

SKF spherical roller thrust bearings have a built-in capacity for high speed. With certain modifications to the internal design and with special precautions related to lubrication, cooling and preload, it is possible to operate the bearings at speeds up to three times greater than the catalogue reference speed (approximately one and a half times the limiting speed).

A bearing arrangement in a disc refiner for very high speed is shown in **fig. 8**.

In this application, a very heavy axial load is shared equally by two spherical roller thrust bearings mounted in tandem and preload applied by two hydraulic pistons. Prior to designing or operating any machine at speeds higher than the thermal reference speed, consult the SKF application engineering service.

*SKF spherical roller thrust bearing arrangement in a high-speed disc refiner, lubricated with circulating oil*

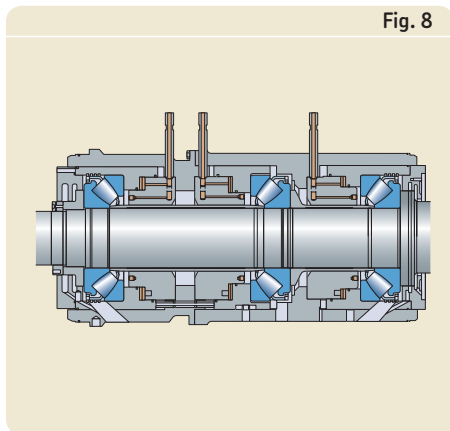

## Low-speed bearing arrangements

In applications such as vertical air preheaters and extruders, speeds can be as low as 0,5 to 5 r/min while loads can be as heavy as  $P = 0,1 C_0$ . High viscosity oils with additives have proven to be effective for these types of applications. For additional information, contact the SKF application engineering service.

Low speed applications such as bridge and crane pivots are considered to be static applications and the bearings should be calculated with a static safety factor of  $s_0 \approx 4$  or greater.

## Stiffness

Some machines require stiffer bearing arrangements than others. To meet those varied requirements, SKF spherical roller thrust bearings can be arranged for different levels of stiffness.

In back-to-back arrangements, the pressure centres of the bearings will be far apart to provide a very stiff arrangement that accommodates bending moments as well as axial and radial loads ( $\rightarrow$  **fig. 9**).

The face-to-face arrangement is not so stiff due to the shorter distance between the pressure centres. However, it is equally stiff for axial load and radial load respectively ( $\rightarrow$  **fig. 10**).

In face-to-face arrangements, the bearings can be placed so that their pressure centres coincide and the whole arrangement will be self-aligning, but with equal stiffness in both the axial and radial direction.

*Back-to-back arrangements provide very high stiffness*

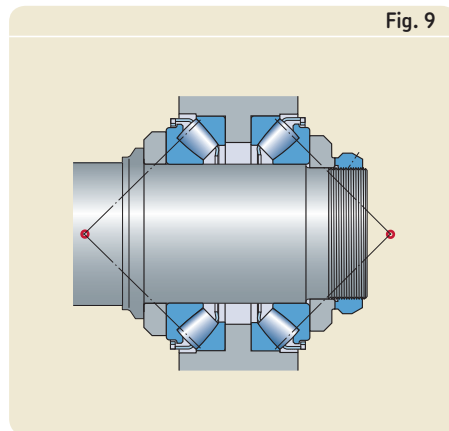

## Design of associated components

### Support of bearing washers

To optimize bearing performance under heavy axial loads, it is vital that the bearing has supports strong enough to prevent deformation of the bearing washers.

The abutment dimensions  $d_{a \min}$  and  $D_{a \max}$  quoted in the product table, starting on **page 36**, apply for axial bearing loads  $F_a \leq 0,1 C_0$ .

If the bearings are subjected to heavier loads, it may be necessary for the bearing washers to be supported across their entire width ( $d_a = d_1$  and  $D_a = D_1$ ). At heavy loads,  $P > 0,1 C_0$ , the shaft washer bore must be fully supported by the shaft, preferably by an interference fit. Even the housing washer should be radially supported ( $\rightarrow$  **fig. 11**).

For further information about dimensioning of washer supports, contact the SKF application engineering service.

*Face-to-face arrangements provide high stiffness*

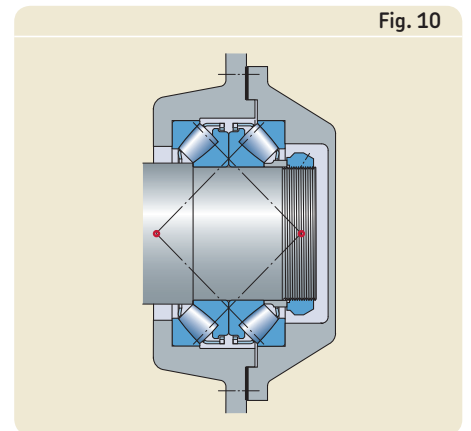

## Seals

The service life of a bearing depends to a large extent on the effectiveness of the seals. Seals prevent the entry of contaminants while retaining the lubricant.

The selection of a seal type depends on the operating conditions and environmental considerations such as

- the type of lubricant
- the sliding velocity of the sealing surfaces
- a vertical or horizontal shaft
- the degree of misalignment
- the type of contamination
- thermal conditions.

Detailed information about selecting the seal type can be found in the SKF catalogue "Industrial shaft seals".

### Seals for grease lubrication

Lubricating greases are relatively easy to retain in the bearing arrangement. As a result, the demands on seals are generally moderate.

SKF radial seals without a garter spring, HM and HMA types, are suitable for low sliding speeds. The seals should be arranged so the lip faces the bearing. V-rings or spring loaded radial seals, e.g. CRW1 design, are equally suitable for retaining grease.

If frequent relubrication is required, the lip of at least one of the seals should be arranged away from the grease so that excess grease can escape via this lip.

More information about sealing arrangements can be found in the section "Grease lubrication", starting on **page 26**.

*Shaft and housing dimensions for support of bearing washers*

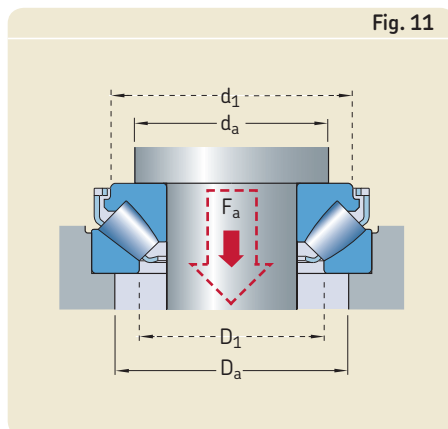

### Seals for oil lubrication

Lubricating oils are generally more difficult to retain in a bearing arrangement than greases. Therefore, spring loaded radial seals are used almost exclusively, e.g. SKF seals of the CRW1, CRWH1, HMS4 or HDS3 designs.

Normally, CRW1 radial seals with a hydro-dynamically formed seal lip, called SKF WAVE, are adequate (→ **fig. 12**). The SKF WAVE seal lip has a sinusoidally formed edge which induces a pumping action to the inside as well as the outside, irrespective of the shaft's direction of rotation.

Due to their internal design, spherical roller thrust bearings create a pumping action which should be considered when selecting seals (→ section "Lubrication and maintenance", starting on **page 24**).

*Spring loaded CRW1 radial seal for oil lubricated arrangements*

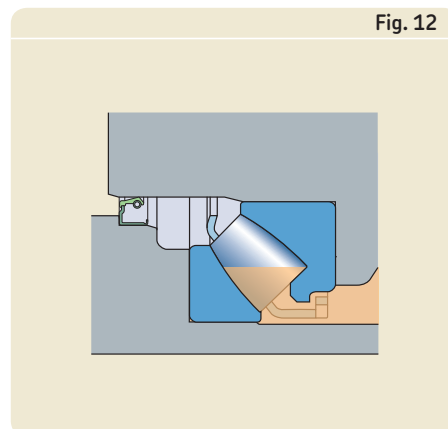

### Contaminant exclusion

V-ring seals are very suitable to prevent ingress of contaminants. They rotate with the shaft, act as flingers and seal against a surface, which is at a right angle to the shaft (→ **fig. 13**).

Radial seals, i.e. CRW1 design, which are primarily intended to prevent ingress of contaminants, should be mounted with the lip pointing away from the bearing.

*V-ring seals are suitable to prevent ingress of contaminants*

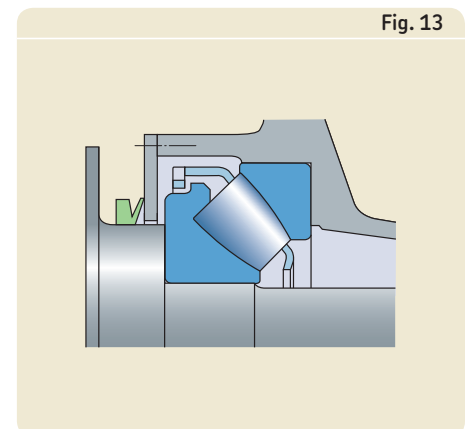

# Typical bearing arrangements

To fully utilize the features of spherical roller thrust bearings, they must be properly applied. One of the advantages of spherical roller thrust bearings is that they can accommodate radial as well as axial loads. This is why a single spherical roller thrust bearing is frequently used in some applications to accommodate combined loads.

Correctly applied, the bearing will then work smoothly as long as  $F_r \leq 0,55 F_a$ . If the bearing must accommodate a heavy radial load,  $F_r > 0,55 F_a$ , the bearing should be combined with another bearing. This second bearing can be a spherical roller thrust bearing, but other bearing types can be used. In applications where a spherical roller thrust bearing is mounted radially free and axial loads may not meet requisite minimums, springs must be used to preload the bearing.

Some typical bearing arrangements incorporating spherical roller thrust bearings are shown below.

## Single direction thrust bearing arrangements

### Bearing arrangement with a single spherical roller thrust bearing, radially located on a vertical shaft

When a spherical roller thrust bearing is axially loaded with at least the minimum requisite bearing load, it can be used as a single bearing to accommodate both the radial and axial loads. (→ **fig. 1**). The bearing at the other end of the shaft, however, should be a radial bearing.

This arrangement is suitable when the axial load always acts in one direction. Typical applications are electric motors, crane pivots and bridges.

### Bearing arrangement with a single spherical roller thrust bearing, radially free on a horizontal or vertical shaft

In this example, the spherical roller thrust bearing is spring preloaded and carries the predominant axial load. The shaft is supported by two radial bearings of which one is locating in the opposite direction (→ **fig. 2**).

This arrangement is suitable when the axial load in one direction is predominant. Typical applications are pinions, pumps and fans.

### Bearing arrangement with a single spherical roller thrust bearing, radially located on a vertical shaft

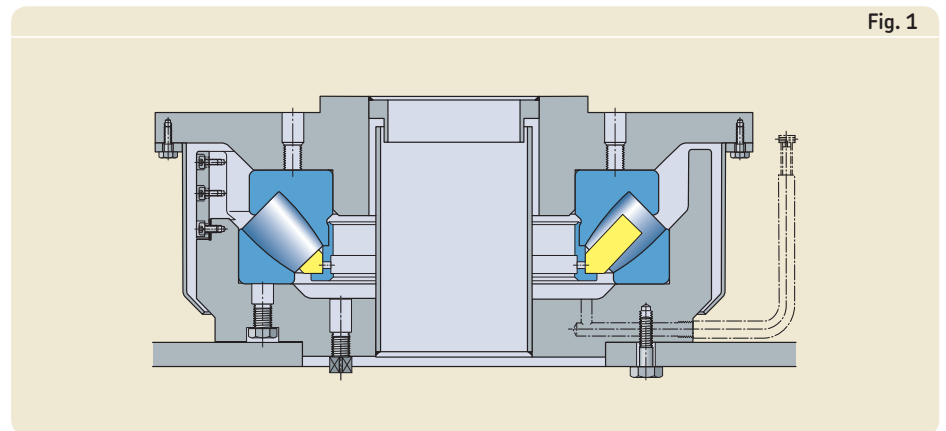

Fig. 1

### Bearing arrangement with a single spherical roller thrust bearing, radially free on a horizontal or vertical shaft

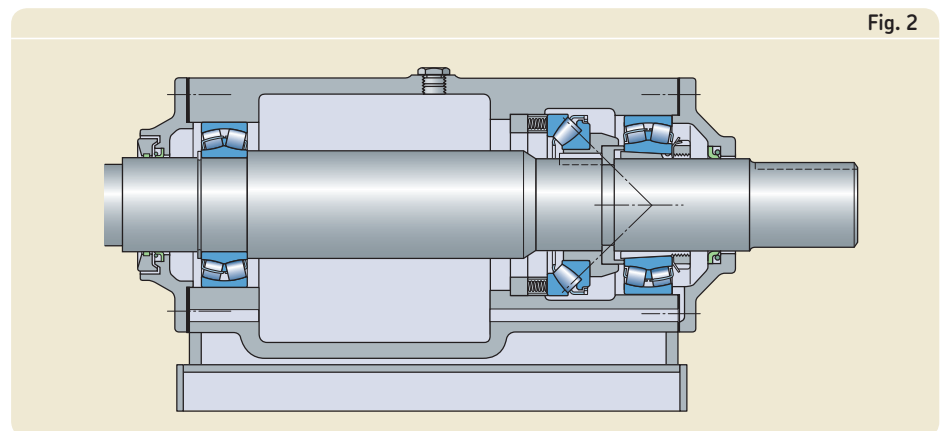

Fig. 2

## Double direction thrust bearing arrangements

### Bearing arrangement with two spherical roller thrust bearings, radially free in a back-to-back or face-to-face arrangement

Bearings in either of these arrangements can carry axial loads in both directions. The minimum axial load is provided by spring preloading the housing washers. The radial loads are accommodated by a separate radial bearing (→ **fig. 3**). The non-locating bearing at the other end of the shaft is a radial bearing.

This bearing arrangement is suitable for axial loads acting in both directions in combination with heavy radial loads and for relatively high speed applications. Typical applications are industrial gearboxes and rolling mills.

### Bearing arrangement with two spherical roller thrust bearings, radially located in a back-to-back or face-to-face arrangement

The housing washers of both bearings can be mounted with a loose fit or an interference fit in the housing. The bearings accommodate axial loads in both directions in combination with simultaneously acting radial loads. They are mounted with a certain internal axial clearance (→ **fig. 4**).

The non-locating bearing at the other end of the shaft is a radial roller bearing.

This arrangement offers a compact solution for applications where there are axial loads in both directions and simultaneously acting radial loads. It is especially suitable for moderate speed applications. Typical applications are marine thrusters and large electric motors.

### Bearing arrangement with two spherical roller thrust bearings, one providing radial support and one radially free

Bearings in this arrangement can be mounted in a back-to-back (→ **fig. 5**) or face-to-face arrangement. The radially guided bearing carries both axial and radial loads while the other spring loaded bearing is radially free in the housing. The non-locating bearing at the other end of the shaft is a radial bearing.

The bearing arrangement is suitable for radial loads and for heavy axial loads acting in one direction and an occasional light load in the opposite direction. The arrangement can also be used for relatively high speed applica-

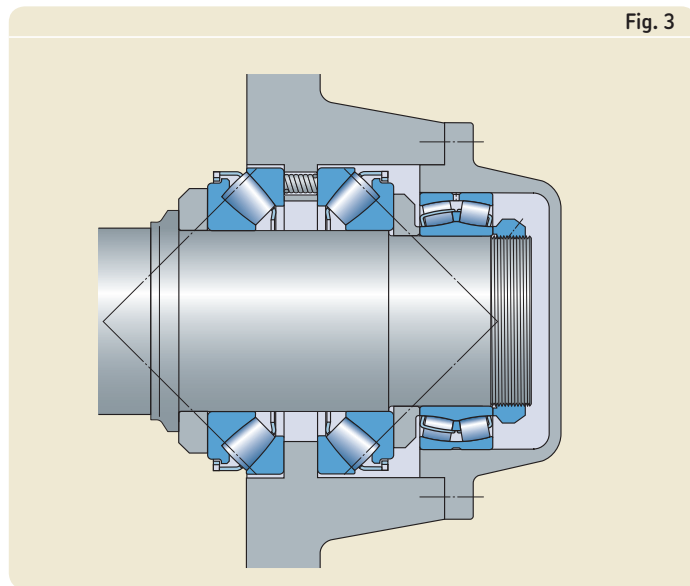

*Bearing arrangement with two spherical roller thrust bearings, radially free in a back-to-back arrangement*

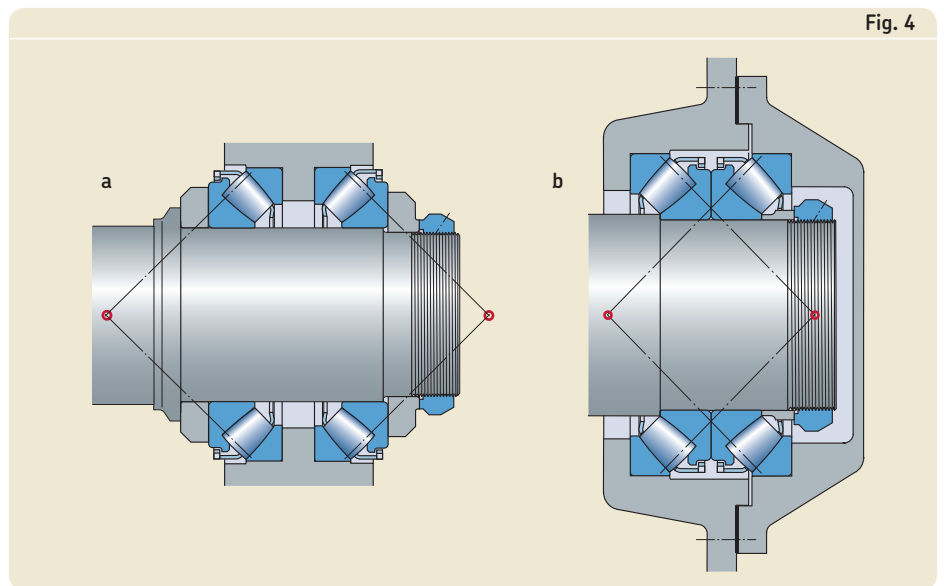

*Bearing arrangement with two spherical roller thrust bearings, radially located in a back-to-back (a) or face-to-face (b) arrangement*

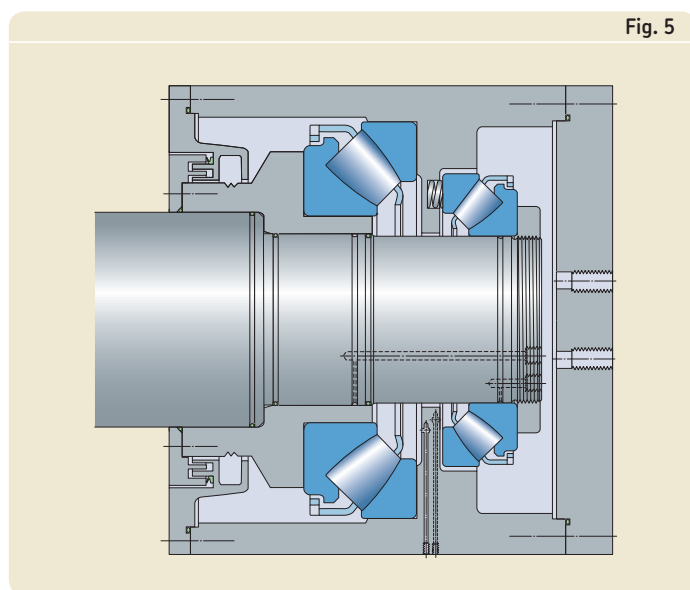

*Bearing arrangement with two spherical roller thrust bearings, one providing radial support and one radially free*

tions. Typical arrangements are disc refiners and small horizontal water turbines.

### Bearing arrangement with a spherical roller thrust bearing combined with a spherical roller bearing – common pressure centre

The bearings in this arrangement are mounted to achieve a common pressure centre, which makes the arrangement self-aligning. The spherical roller thrust bearing is radially free and accommodates axial loads only. Radial loads are accommodated by the spherical roller bearing. The minimum axial load on the spherical roller thrust bearing is achieved by spring loading the housing washer (→ **fig. 6**). The non-locating bearing at the other end of the shaft is a radial roller bearing.

This bearing arrangement is suitable for radial loads and heavy axial loads acting in one direction and an occasional light axial load in the opposite direction. This applies for low as well as high speed applications. Typical arrangements are propeller thrust bearing arrangements, waterjets and pumps.

### Bearing arrangement with two spherical roller thrust bearings in tandem arrangement

For very heavy axial loads, two spherical roller thrust bearings mounted in tandem can be used to carry the predominant axial load. The load is equally shared by the two bearings by means of two hydraulic pistons. The spherical roller thrust bearings are radially free and the shaft is radially supported by two radial bearings.

Alternatively, one of the bearings in the tandem arrangement can be used for radial support as well, together with a third spherical roller thrust bearing that provides shaft location in the other direction (→ **fig. 7**).

The arrangement is suitable when the axial load is very heavy in one direction. Typical arrangements are spindle units and disc refiners.

Fig. 6

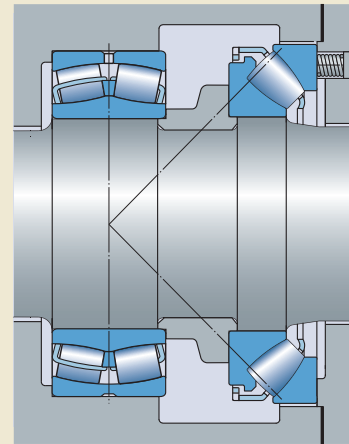

*Bearing arrangement with a spherical roller thrust bearing combined with a spherical roller bearing – common pressure centre*

Fig. 7

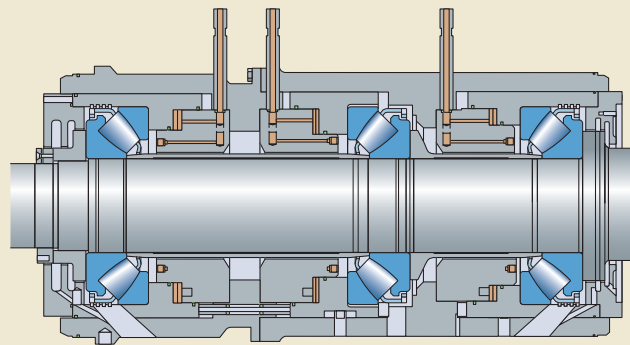

*Bearing arrangement with two spherical roller thrust bearings in tandem arrangement*

Fig. 8

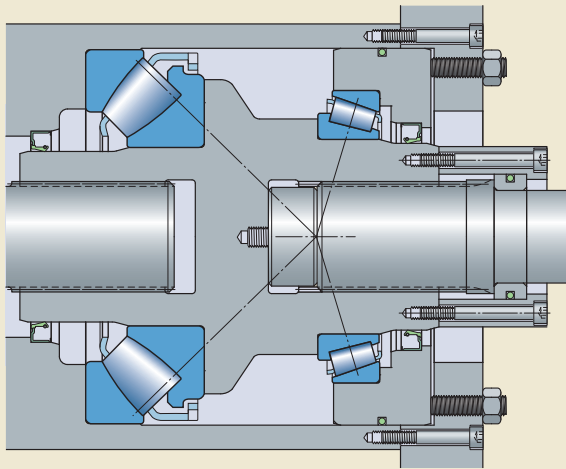

*Bearing arrangement with a spherical roller thrust bearing combined with a tapered roller bearing*

### Bearing arrangement with a spherical roller thrust bearing combined with a tapered roller bearing

Both bearings in this arrangement are radially guided, not preloaded, and mounted in a face-to-face arrangement. Each bearing can take axial load in one direction only. The bearing that is axially loaded carries the simultaneously acting radial load as well (→ fig. 8). If a non-locating bearing is required at the other end of the shaft, a radial bearing needs to be used.

The bearing arrangement is suitable for axial loads in both directions in combination with radial loads. The predominant axial load is accommodated by the spherical roller thrust bearing.

Typical arrangements are hydraulic motors and injection moulding machines.

Fig. 9

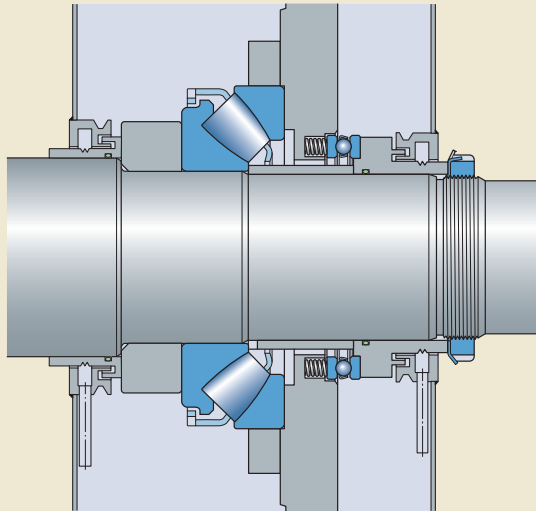

*Bearing arrangement with a spherical roller thrust bearing combined with a thrust ball bearing*

### Bearing arrangement with a spherical roller thrust bearing combined with a thrust ball bearing

The spherical roller thrust bearing in this arrangement is radially guided and can accommodate axial and radial loads. To provide the requisite minimum axial load, a thrust ball bearing is adjusted against the spherical roller thrust bearing by means of springs (→ fig. 9). The non-locating bearing at the other end of the shaft is a radial bearing.

The bearing arrangement is suitable for predominant axial loads acting in one direction. Examples of this arrangement include water turbines and pulp boilers.

# Lubrication and maintenance

## Lubricants

Generally, lubrication with oil or grease containing EP additives is recommended for spherical roller thrust bearings.

## Pumping effect

Because of their internal design, spherical roller thrust bearings have a pumping action that can be taken advantage of to provide circulation of the lubricating oil. The pumping action must be considered when selecting the type of lubricant and seals (→ **diagram 1**).

## Oil viscosity

The selection of an oil or grease is primarily based on the viscosity required to adequately lubricate the bearing. The viscosity of a lubri-

cant is temperature dependent and decreases as temperature increases. In order to form a sufficient film thickness in the contact area between the rolling elements and raceways, the oil must retain a minimum viscosity at normal operating temperature.

To determine the suitable lubricant viscosity at a certain operating temperature, use the information provided in the SKF General Catalogue or the SKF Interactive Engineering Catalogue online at [www.skf.com](http://www.skf.com).

## Cleanliness

Cleanliness is very important for the performance of rolling bearings. This is reflected in the SKF rating life equation (→ section "Selection of bearing size", starting on **page 12**).

## Oil lubrication

Oil is the preferred lubrication method for spherical roller thrust bearings, particularly in applications with static load conditions, e.g. bridge pivots, to avoid bearing damage from vibration when not rotating.

Oil bath lubrication should be chosen when the need for cooling of the bearing is moderate.

Circulating oil lubrication should be chosen when the operating temperature is high.

Irrespective of the oil lubrication method, there must always be a communicating duct between the oil reservoirs on both sides of the bearing (→ **fig. 1**).

For information about suitable sizes for oil ducts, contact the SKF application engineering service.

*Pumping effect in spherical roller thrust bearings (example of a 29420 E bearing)*

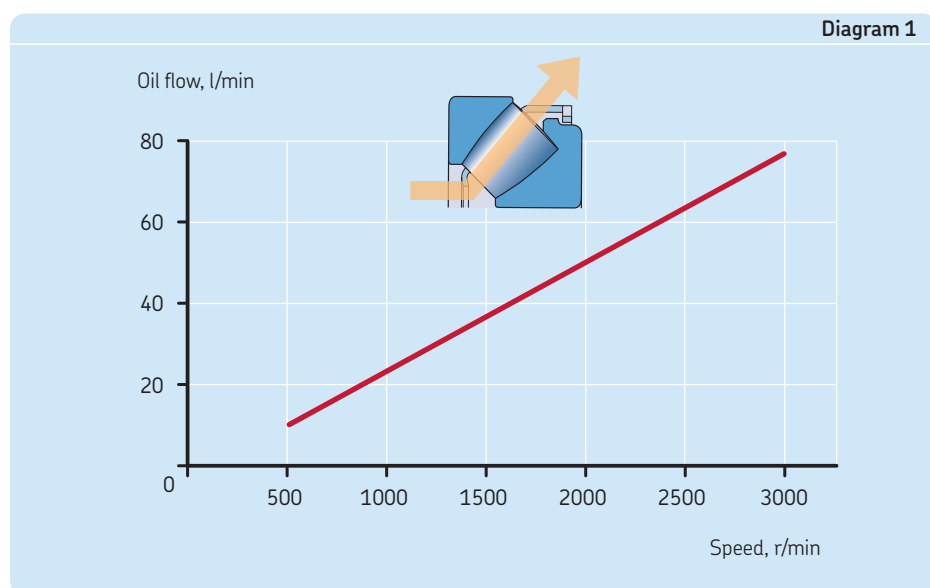

*A communication duct provides equal oil level on both sides of the bearings*

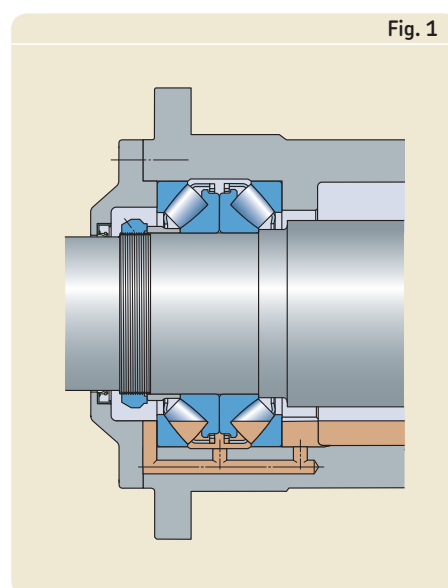



## Oil bath lubrication

For vertical shafts, oil bath lubrication is an appropriate choice. The pumping effect of the bearing can be used to force oil through the bearing.

### Oil levels

The recommended oil level for a vertical shaft is shown in **fig. 2**.

For bearings on a horizontal shaft, the oil level should be at distance "a" from the centre of the bearing (**→ fig. 3**).

$$a = 0,5 d_m \pm 2 \text{ mm for } d < 200 \text{ mm}$$

$$a = 0,5 d_m + 0 \text{ to } + 5 \text{ mm for } d \geq 200 \text{ mm}$$

where

$$d_m = \text{bearing mean diameter} \\ = 0,5 (d + D), \text{ mm}$$

$$d = \text{bearing bore diameter, mm}$$

$$D = \text{bearing outside diameter, mm}$$

However, for low and medium speed applications, the bearing can be totally immersed in oil.

## Circulating oil lubrication

In many cases, the pumping action of a spherical roller thrust bearing is sufficient to provide effective oil circulation to cool the bearing.

If the pumping action does not suffice, it might be necessary to circulate oil by means of a pump. The direction of the oil circulation should coincide with the pumping action of the spherical roller thrust bearing.

The higher the operating temperature, the more rapidly the lubricating oil will oxidize. An increase in bearing temperature also means that the oil viscosity is reduced and the lubricant film is thinner.

Lubricating with circulating oil extends the oil change interval.

To improve cleanliness, the oil should be cleaned by a filter before it is pumped back to the bearing (**→ fig. 4**).

## Cooling

At moderate speeds, a simple cooling system can be arranged by including a coil of cooling tubes in the oil tank. In high-speed applications and in the case of high ambient temperatures, the oil flow rate required to maintain a suitable running temperature must be estimated.

Effective cooling is important if spherical roller thrust bearings are to operate at very high speeds.

Cooling can be accomplished via an oil cooler in a circulating oil system (**→ fig. 4**).

To define necessary oil flow rates, contact the SKF application engineering service.

## Heating

When the ambient temperature is low, e.g. for bridge and crane pivot applications, it might be necessary to heat the oil to achieve suitable viscosity for pumping lubricant to the bearing.

Recommended oil level for vertical shaft applications

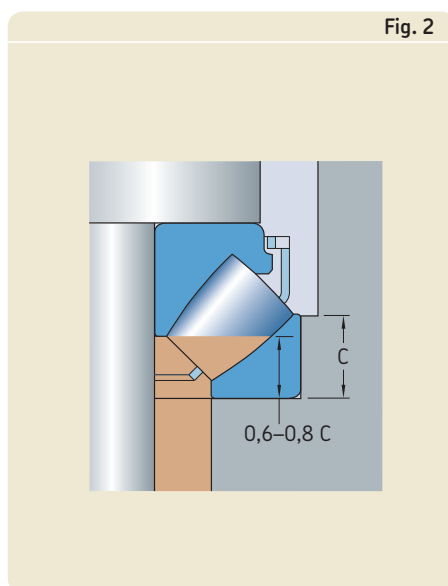

Recommended oil level for horizontal shaft applications

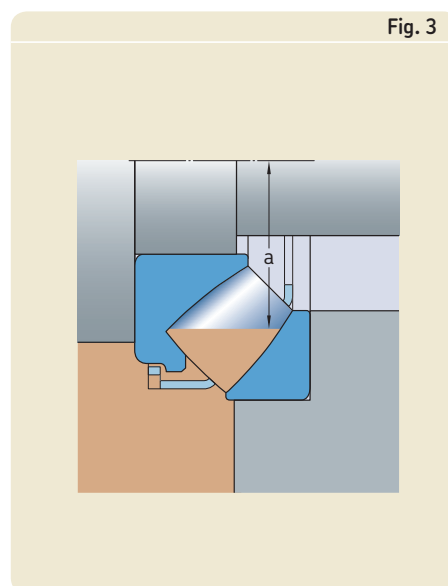

Circulating oil system with cooler and filter

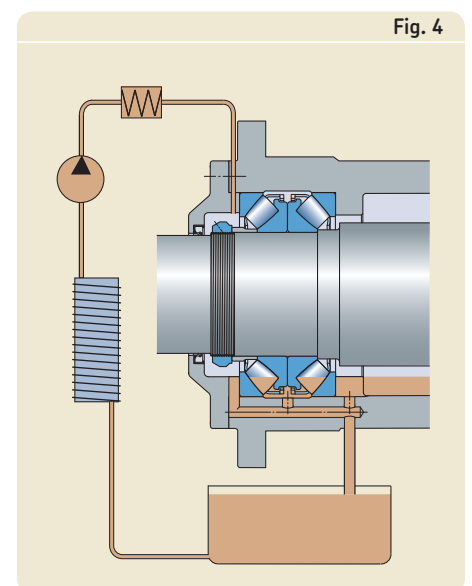

## Grease lubrication

When lubricating with grease, the roller end/flange contacts must be adequately supplied with lubricant. Depending on the application, this can best be done by completely filling the bearing and housing with grease before the initial start-up and then following up with a regular relubrication schedule.

It is important that excess grease can leave the bearing (→ **figs. 5 and 6**).

### Vertical shaft

To retain the grease in the bearing arrangement of a vertical shaft, a radial seal is applied underneath the bearing. The grease supply duct is positioned on the housing washer side (→ **fig. 5**).

### Horizontal shaft

The sealing arrangement for horizontal shafts should be designed so that the fresh grease passes through the bearing and used grease is purged on the shaft washer side (→ **fig. 6**).

### Suitable greases

The most suitable SKF greases for lubrication of spherical roller thrust bearings are listed in **table 1**. Their technical specifications can be found in **table 2**.

### Regreasing interval

Proper lubrication requires regreasing at regular intervals. Be careful not to overgrease the bearing, as this can lead to increased operating temperature.

The relubrication interval  $t_f$  for normal operating conditions is provided in **diagram 2**. The diagram is valid for bearings on horizontal shafts operating under clean conditions.

The value on the x axis is obtained from  $4 n d_m$  ( $4 \times$  operational speed  $\times$  bearing mean diameter).

The  $t_f$  value is then derived considering the load magnitude given by the load ratio  $C/P$ . The relubrication interval  $t_f$  is an estimated value and valid for

- an operating temperature of 70 °C (160 °F), using a good quality mineral oil based grease with a lithium soap
- a rotating shaft washer
- a horizontal shaft.

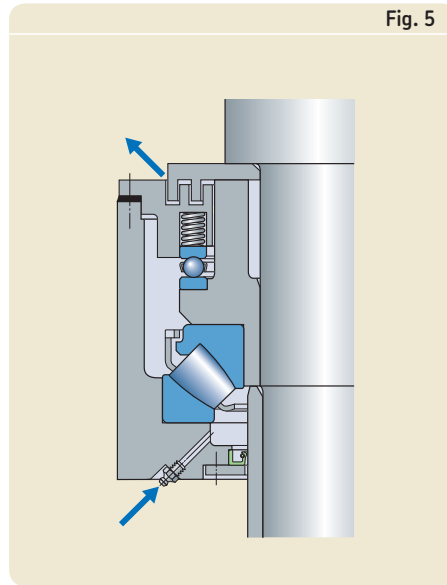

**Sealing arrangement for a vertical shaft – the grease inlet is positioned just underneath the bearing**

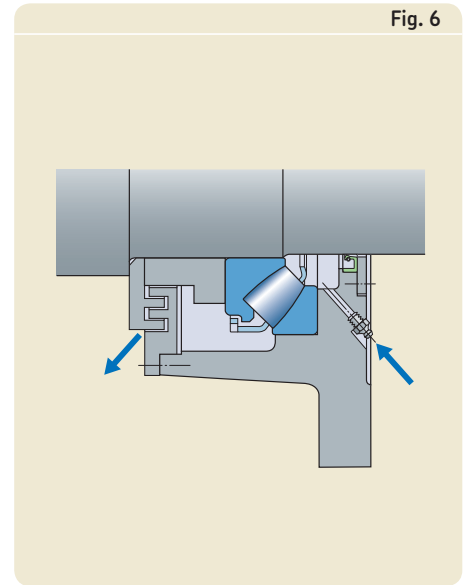

**Sealing arrangement for a horizontal shaft – the grease inlet is positioned on the housing washer side**

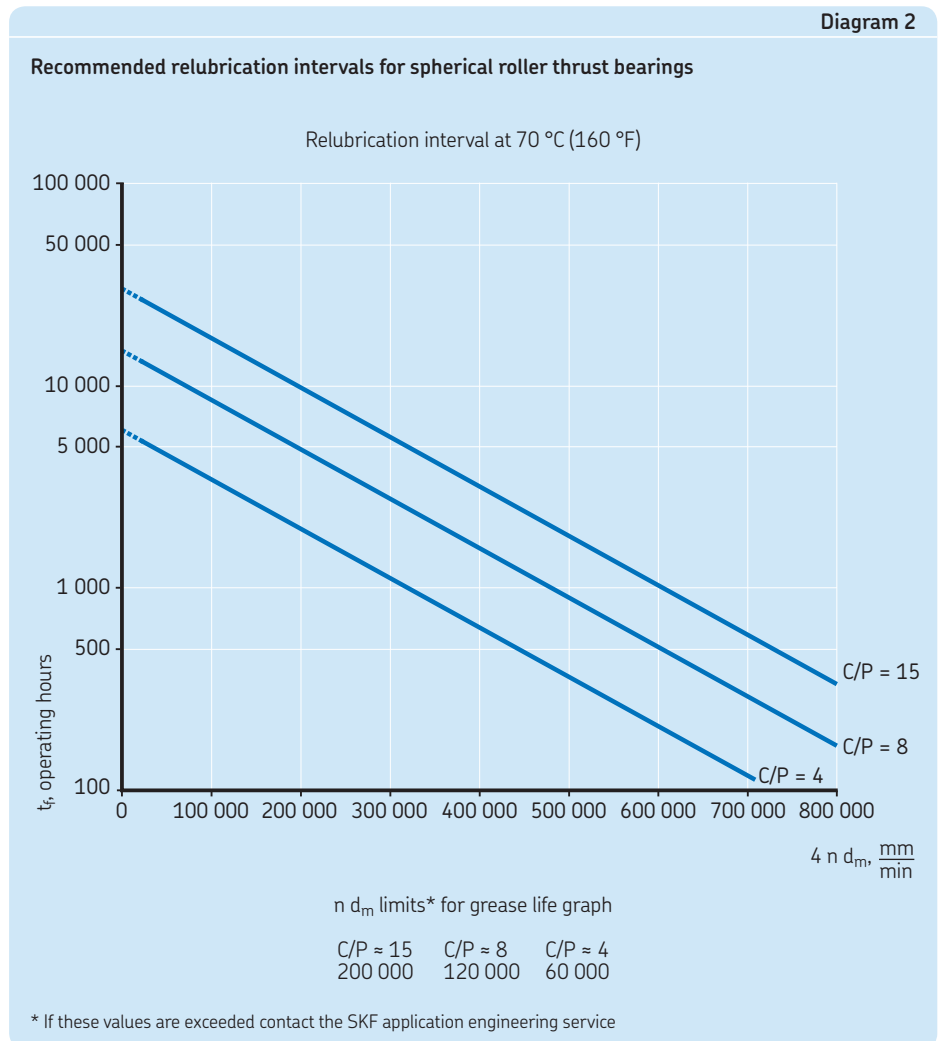

Table 1

## SKF standard bearing greases for spherical roller thrust bearings

Grease designation	Bearing operating conditions						
	Very high speed	Very low speed and/or oscillating movements	Low torque and friction	Severe vibration	Heavy load	Rust inhibiting properties	Water resistance
LGEP 2	o	o	–	+	+	+	+
LGHB 2	o	+	–	+	+	+	+
LGEM 2	–	+	–	+	+	+	+
LGEV 2	–	+	–	+	+	+	+
LGWM 1	o	o	o	–	+	+	+

+ = Very suitable    o = Suitable    – = Unsuitable

For additional information, contact the SKF application engineering service

Table 2

## Technical specifications

Grease designation	Description	NLGI class	Thickener	Base oil type	Base oil viscosity (mm <sup>2</sup> /s)		Temperature range <sup>1)</sup> (°C)	
					40 °C	100 °C	LTL	HTPL
LGEP 2	Heavy load	2	Lithium	Mineral	200	16	–20	+110
LGHB 2	EP high viscosity high temperature	2	Complex calcium sulphonate	Mineral	400–450	26,5	–20	+150
LGEM 2	High viscosity with solid lubricants	2	Lithium	Mineral	500	32	–20	+120
LGEV 2	Extra high viscosity with solid lubricants	2	Lithium-calcium	Mineral	1 020	58	–10	+120
LGWM 1	EP – low temperature	1	Lithium	Mineral	200	16	–30	+110

LTL Low Temperature Limit  
HTPL High Temperature Performance Limit

<sup>1)</sup> For safe bearing operating temperatures where the grease will function reliably, → the SKF General Catalogue 6000, section "Temperature range – the SKF traffic light concept", starting on page 232

To account for the accelerated ageing of the grease with increasing temperature, SKF recommends halving the relubrication interval obtained from the diagram for every 15 °C increase in bearing temperature between 70 °C and the operating temperature limit for the grease. For spherical roller thrust bearings, do not extend the relubrication interval for operating temperatures below 70 °C.

- For bearings on vertical shafts with the shaft washer at the top, the intervals obtained from the diagram should be halved.

- For a rotating housing washer, oil lubrication is recommended.
- For bearings on vertical shafts with the shaft washer at the bottom, contact the SKF application engineering service.

If the determined  $t_f$  value from the diagram proves to be insufficient for a particular application

- check the grease for water content and contamination
- check the bearing operating temperature
- consider another grease

- check the bearing application conditions such as load, misalignment etc.

To establish a proper relubrication interval for spherical roller thrust bearings used in critical positions in process industries, an interactive procedure is recommended. In these cases it is advisable to relubricate more frequently and adhere strictly to the regreasing quantity (→ "Relubrication procedures" below).

Before regreasing, the appearance of the grease and the degree of contamination due to particles and water should be checked. SKF also recommends a complete check of the

seals for wear, damage, and leakage. When the condition of the grease and associated components are satisfactory, the relubrication interval can be gradually increased.

## Relubrication procedures

The most common relubrication procedures for spherical roller thrust bearings are replenishment and continuous lubrication. The choice depends on the operating conditions.

- Replenishment is a convenient and preferred procedure in many applications: it enables uninterrupted operation and provides, when compared to continuous relubrication, a lower steady state temperature.
- Continuous relubrication is used when the calculated relubrication intervals are short or due to the adverse effects of contamination.

When using different bearing types on the same shaft, it is common practice to apply the lowest individual calculated relubrication interval for all bearings. The guidelines and grease quantities for the relubrication procedures are provided below.

### Replenishment

Suitable quantities for replenishment can be obtained from

$$G_p = 0,005 D H$$

where

$G_p$  = grease quantity to be added when replenishing, g

$D$  = bearing outside diameter, mm

$H$  = bearing height, mm

To facilitate the supply of grease using a grease gun, a grease nipple must be provided on the housing (→ **figs. 5 and 6, page 26**).

To be effective in replacing old grease, it is important to replenish while the machine is in operation. In cases where the machine is not in operation, the bearing should be rotated during replenishment.

Where centralized lubrication equipment is used, provision must be made to adequately pump the grease at the lowest expected ambient temperature.

SKF recommends replacing complete grease fill after approximately 5 replenishments.

## Continuous relubrication

Due to possible churning of the grease that can lead to increased temperatures, continuous relubrication is only recommended when operating speeds are low,  $n d_m$  values below 75 000. The quantity for relubrication per time unit is derived from the equation for  $G_p$  (see above) by spreading this quantity over the relubrication interval.

## Maintenance

Proper bearing maintenance is a key factor to keep equipment running on schedule. Foresighted planning, use of professional maintenance techniques and tools combined with the appropriate bearing accessories are vital.

Further information about spherical roller thrust bearing maintenance can be found in the SKF Bearing Maintenance Handbook or online at [www.apitudexchange.com](http://www.apitudexchange.com).

### What to look for during operation

Checking the machine condition during operation and planning for maintenance is important. Bearings are vital components in most machines and monitoring their condition represents an increasingly important activity in the field of preventive maintenance. A variety of systems and equipment are available to monitor bearings.

However, for practical reasons, not all machine functions are monitored using advanced instrumentation. By remaining alert for "trouble signs", such as noise, increases in temperature and vibration etc., problems can be detected.

### Listen

Bearings in good operating condition produce a soft purring noise. Grinding, squeaking and other irregular sounds usually point to bearings in poor condition.

Damaged bearings produce irregular and loud noises. Instruments such as the SKF electronic stethoscope make "listening" more accurate and help to detect damage at an earlier stage.

### Feel the temperature

Continually check the temperature around the bearing. Any change in temperature can be an indication of a malfunction if the running conditions have not been altered. Temperature checks can be performed with an SKF thermometer.

After relubrication, a natural temperature rise lasting one or two days can occur.

### Look

Check the condition of the seals near the bearing to be sure that they are operating satisfactorily and have not allowed contaminants to penetrate. Oil leaks are usually signs of worn seals, seal defects or loose plugs. Check the bearing arrangement and replace worn seals immediately.

Discoloration or darkening are usually signs that the lubricant contains impurities.

## Relubrication

Relubrication is best performed when the bearing is running. Relubricate with small quantities each time.

Periodically, clean out used grease or purge out through drain plugs. When lubricating, always keep contaminants away from the grease.

### Checking the oil

Check the oil level and when necessary fill up or replace with the same type of oil. Take a sample of the used oil and compare it with fresh oil. If the sample looks cloudy, it may be mixed with water and should be replaced.

Dark oil is a sign of dirt, or indicates that the oil has started to carbonize. Clean the bearing and change the oil with a similar type of oil.

### Condition monitoring of bearings in operation

It is advisable to systematically check the bearing condition. A lack of lubricant, excessive loads, high operating temperatures and mounting errors can all contribute to premature bearing failure. By methodical condition monitoring, bearing damage can be detected at an early stage (→ **fig. 7**). It is then easy to plan for bearing replacement.

SKF can help you select the right monitoring system, train your personnel and install the system (→ **pages 32 and 33**).

## Prepared for vibration analysis

Bearing damage can be identified by its defect frequency. To simplify vibration analysis, the packaging of SKF spherical roller thrust bearings is marked with individual bearing data required for damage analysis (→ fig. 8).



SKF offers a range of different instruments for condition monitoring. An example is the range of portable MARLIN machine inspection systems for fast and reliable vibration analysis

The packaging of SKF spherical roller thrust bearings is marked with vibration analysis data



# Mounting and dismounting

## Mounting

### Mounting bearings with an interference fit

SKF spherical roller thrust bearings are separable so that the housing washer and the shaft washer with rollers and cage are mounted independently (→ **fig. 1**).

One or both of the washers can have an interference fit.

Depending on whether the interference fit is between a shaft washer and shaft or housing washer and housing, the shaft washer or the housing should be heated before mounting.

To mount a washer with an interference fit on a shaft, heat the washer to about 80 to 90 °C (175 to 195 °F) above the temperature of the shaft. This can be done by means of an SKF induction heater (→ **fig. 2**), a heating cabinet or an oil bath.

### Double direction thrust bearing arrangements – paired spherical roller thrust bearings

Spherical roller thrust bearings mounted in pairs must be adjusted to a certain axial clearance, or preloaded during assembly (→ section “Axial clearance and preload”, starting on **page 16**).

In some cases, the correct position of the bearings must be determined from measurements of the bearing heights and the adjacent components before mounting.

New, unique detailed mounting and dismounting instructions for SKF spherical roller thrust bearings are available online at [www.skf.com/mount](http://www.skf.com/mount).

### Replacing bearings where axial forces are transmitted via the inside face of the shaft washer

Generally, when replacing a spherical roller thrust bearing of one design with a corresponding bearing of another design, it is important to consider the need of introducing a distance sleeve or modifying the available sleeve.

When an SKF spherical roller thrust bearing with a machined cage is to be replaced by an E design bearing with a pressed steel cage, and axial forces are transmitted via the cage guiding sleeve, it is necessary to insert a spacer sleeve between the shaft abutment and the shaft washer (→ **fig. 3**).

If an SKF bearing of the earlier B design mounted with a spacer sleeve is to be replaced, the spacer sleeve generally needs to be modified (→ **fig. 4**).

For SKF spherical roller thrust bearings, appropriate dimensions for the sleeves can be found in the product table starting on **page 36**.



*Spherical roller thrust bearings are separable, which facilitates mounting*

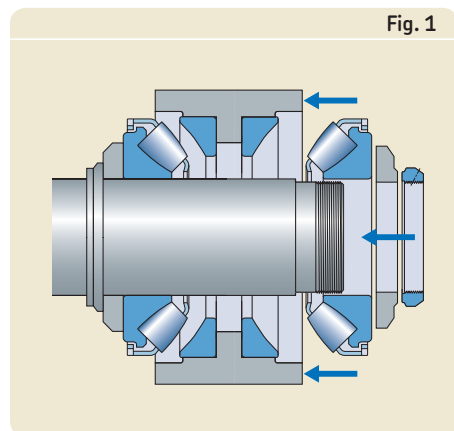

*SKF offers a wide range of induction heaters to facilitate mounting a bearing with an interference fit on a shaft*

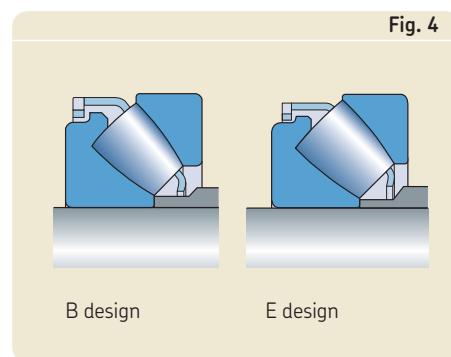
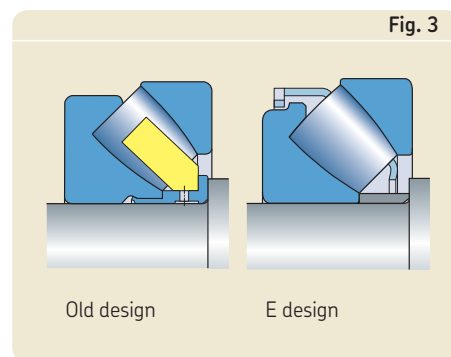

# Dismounting

## Removing the shaft washer

A considerable amount of force is required to remove a washer mounted with an interference fit. Washers of small and medium size bearings can usually be removed using a mechanical or hydraulic withdrawal tool.

## Applying the SKF oil injection method for dismounting spherical roller thrust bearings

The use of the SKF oil injection method (→ fig. 5), in combination with a suitable mechanical withdrawal tool, simplifies the removal of larger shaft washers.

This method involves injecting oil under high pressure between the washer bore and the shaft seat surface until the two surfaces are separated. The resulting oil film considerably reduces the requisite dismounting force. However, this requires that the shaft has oil ducts and grooves which are necessary for this type of dismounting. Dimensions can be found in table 1.

Due to the irregular shape and sectional height of the shaft washer, the groove must be placed where the shaft washer cross section is the largest. This is approximately a distance of one third of the washer height measured from the outside face (→ table 1).

*The use of the SKF oil injection method simplifies dismounting of a shaft washer having a tight fit on the shaft*

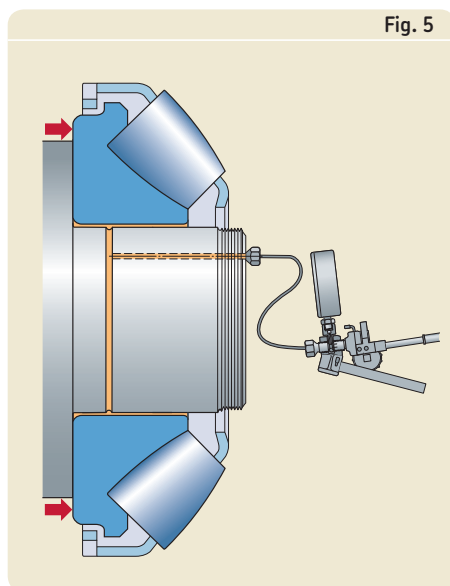

If the shaft washer has to be moved over a long distance on the shaft, more than one groove and duct might be required. To prevent the washer from getting stuck, the shaft should, where possible, be designed for a clearance fit.

Table 1

Recommended dimensions for oil supply ducts, grooves and threaded holes for connecting the oil supply

Shaft diameter over	incl.	Dimensions			
		$b_a$	$h_a$	$r_a$	N
mm		mm			
100	100	3	0,5	2,5	2,5
	150	4	0,8	3	3
	200	4	0,8	3	3
200	250	5	1	4	4
	250	5	1	4	4
	300	6	1,25	4,5	5
400	500	7	1,5	5	5
	500	8	1,5	6	6
	650	10	2	7	7
800	1 000	12	2,5	8	8

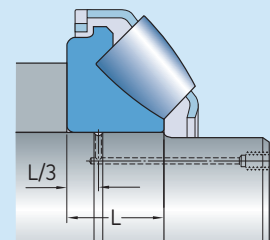
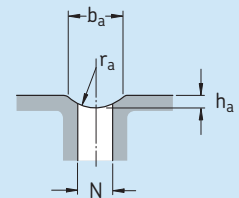

Thread $G_a$	Design	Dimensions		$N_a$
		$G_b$	$G_c^{1)}$ max	
-		mm		
M 6	A	10	8	3
G 1/8	A	12	10	3
G 1/4	A	15	12	5
G 3/8	B	15	12	8
G 1/2	B	18	14	8
G 3/4	B	20	16	8

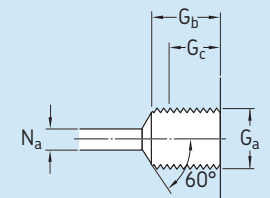

Design A

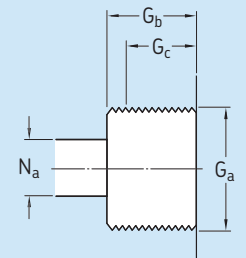

Design B

<sup>1)</sup> Effective threaded length

# Service for a lasting partnership



## Integrated platform for asset efficiency optimization

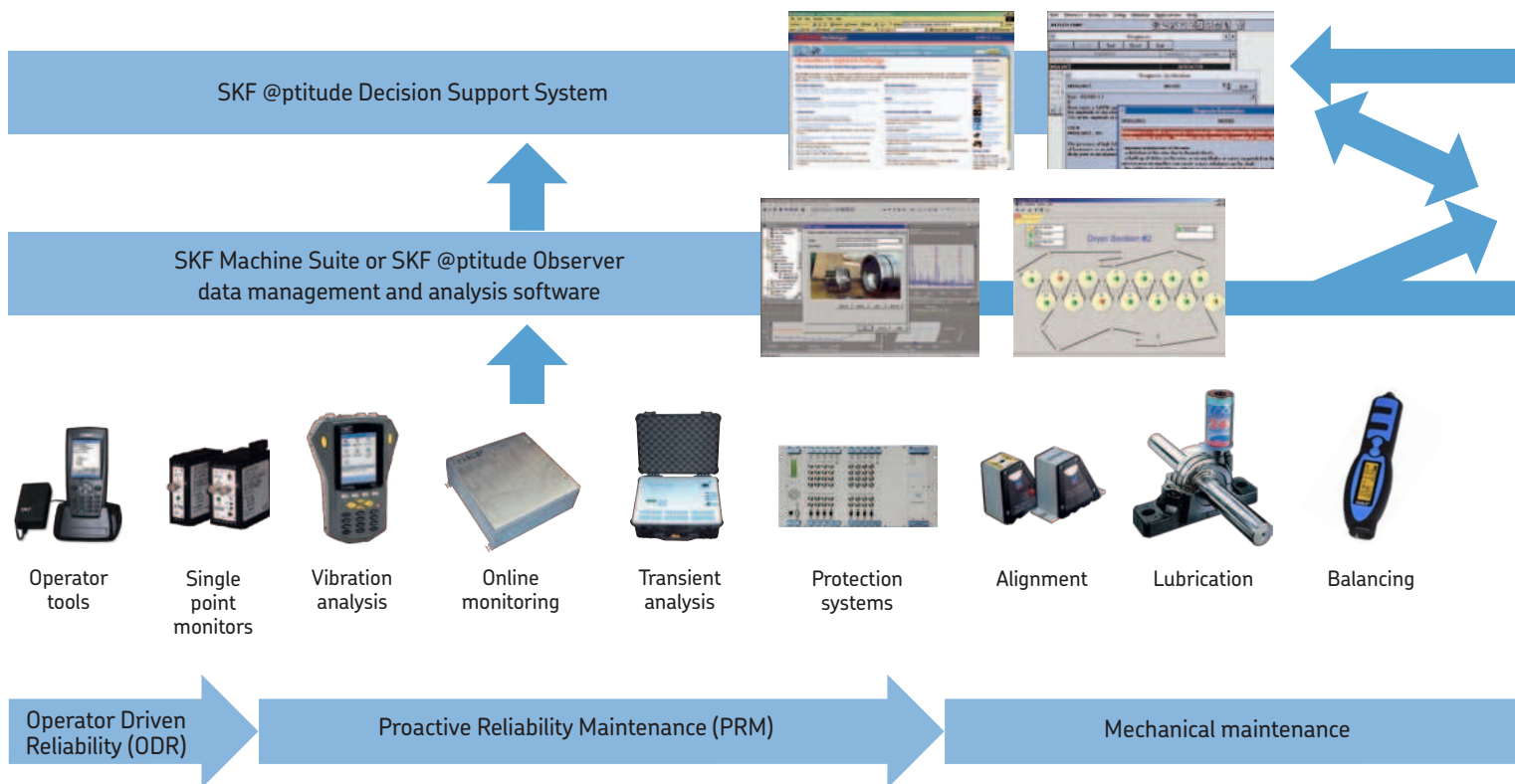

*SKF Reliability Systems offers data acquisition hardware, condition monitoring software, decision support systems, and reliability and logistics services.*



Based on more than 100 years of experience with rotating equipment, SKF's expertise begins at the component level and extends to a deep understanding of the technologies required to improve manufacturing processes.

Using this knowledge, SKF can work with you to design more efficiency into your machines and then provide maintenance solutions to keep those machines in peak operating condition.



B

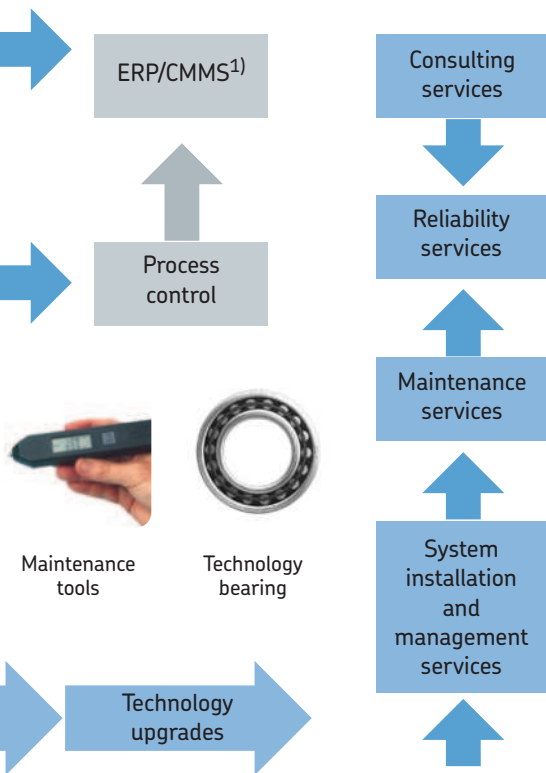

<sup>1)</sup> Enterprise Resource Planning/Computerized Maintenance Management System.

### SKF concepts for creating customer value

With experience in virtually every industrial sector, SKF can provide solutions that go beyond simple maintenance to improve machine performance and productivity. With our Total Shaft Solutions concept, customers can take full advantage of our in-depth competence including, but not limited to

- root cause failure analysis
- maintenance assessments
- predictive and preventive maintenance
- lubrication and filtration management
- equipment maintenance and monitoring – fans, pumps, gearboxes and spindles
- precision balancing
- precision alignment
- applications-specific training
- component and technology upgrades
- installation and repair services.

Another SKF concept that embraces a broader view of improving machine reliability is called Asset Efficiency Optimization (AEO). As the name implies, AEO recognizes the importance of treating machinery and equipment as plant assets. SKF programmes that take a systems approach to managing these assets include

- Operator Driven Reliability (ODR)
- Proactive Reliability Maintenance (PRM)
- Integrated Maintenance Solutions, which include all-inclusive contractual programmes.

For more information about SKF competencies and services contact your local SKF representative.

SKF uses its own product, service and knowledge capabilities, in combination with other providers, to implement a complete reliability programme based on specific business goals.

# Bearing data – general

## Dimensions

The boundary dimensions of SKF spherical roller thrust bearings are in accordance with ISO 104:2002.

## Tolerances

SKF spherical roller thrust bearings are produced as standard to Normal tolerances in accordance with ISO 199:2005.

However, the SKF standard tolerance for the height H is considerably tighter than specified by ISO (→ **table 1**). For SKF Explorer bearings it is even tighter.

**Table 1**

Bearing bore diameter d		SKF height (H) tolerance	
over	incl.	high	low
mm		µm	
50	80	0	-125/-100 <sup>1)</sup>
80	120	0	-150/-100 <sup>1)</sup>
120	180	0	-175/-125 <sup>1)</sup>
180	250	0	-200/-125 <sup>1)</sup>
250	315	0	-225/-150 <sup>1)</sup>
315	400	0	-300/-200 <sup>1)</sup>
400	500	0	-400
500	630	0	-500
630	800	0	-630
800	1 000	0	-800
1 000	1 250	0	-1 000
1 250	1 600	0	-1 200

<sup>1)</sup> Valid for SKF Explorer bearings

## Cages

Bearings identified with the suffix E up to and including size 68 have a stamped steel window-type cage. All other bearings have a machined brass or steel cage guided by a sleeve that is fixed in the shaft washer bore. In all bearings, the cage (and sleeve) forms a non-separable assembly with the rollers and shaft washer.

## Misalignment

By virtue of their design, spherical roller thrust bearings are self-aligning, i.e. they can accommodate misalignment of the shaft relative to the housing and shaft deflections during operation.

The permissible misalignment is reduced as the load increases. The values indicated in **table 2** can be applied provided there is constant misalignment relative to the housing washer.

In practice, this means no problem for the vast majority of applications.

Whether the permissible misalignment can be fully exploited depends on the design of the bearing arrangement, the type of seal etc.

When designing bearing arrangements where the housing washer is to rotate, or where there is a risk that the shaft washer will wobble, it is advisable to contact the SKF application engineering service.

**Table 2**

Permissible angular misalignment			
Bearing series	Permissible misalignment when bearing load $P_0$ <sup>1)</sup>		
	< 0,05 C <sub>0</sub>	> 0,15 C <sub>0</sub>	> 0,3 C <sub>0</sub>
degrees			
292 (E)	2	1,5	1
293 (E)	2,5	1,5	0,3
294 (E)	3	1,5	0,3

<sup>1)</sup>  $P_0 = F_a + 2,7 F_r$

## Speeds

There is a speed limit for the operation of spherical roller thrust bearings. Generally, it is the permitted operating temperature of the lubricant that sets the limit. In cases where cooling facilities are used and the lubricant is properly utilized, the limit is set by the cage properties.

## Reference speeds

The reference speed for a bearing represents the speed at which, under specified operating conditions and heat flow from the bearing, an equilibrium is reached between the heat generated by the friction in the bearing and the heat removed from the bearing via the shaft, housing and, if applicable, the lubricant. The reference conditions for obtaining this balance are according to ISO 15312:2003.

It is possible to operate spherical roller thrust bearings above the reference speed if proper lubrication can be achieved (minimized friction) and cooling facilities are used.

## Limiting speeds

The limiting speed is based on the demand of high-speed operating applications and takes into account criteria such as cage strength, running accuracy, form stability and gyratory forces acting on the rollers.

It is possible to run spherical roller thrust bearings at higher speeds than the limiting speeds shown in the bearing tables. However, bearings with special features, such as those with increased running accuracy, may need to be used. In such cases, contact the SKF application engineering service.

## Influence of operating temperature on the bearing materials

All SKF spherical roller thrust bearings are subjected to a special heat treatment so they can be used at temperatures up to +200 °C (390 °F).

## Minimum load

In order to provide satisfactory operation, spherical roller thrust bearings, like all ball and roller bearings, must always be subjected to a given minimum load, particularly if they are to operate at high speeds or are subjected to high accelerations or rapid changes in the direction of load. Under such conditions, the inertia forces of the rollers and cage, and the friction in the lubricant, can have a detrimental influence on the rolling conditions in the bearing and may cause damaging sliding movements to occur between the rollers and raceways.

The requisite minimum axial load to be applied to spherical roller thrust bearings can be estimated using

$$F_{am} = 1,8 F_r + A \left( \frac{n}{1\,000} \right)^2$$

where

$F_{am}$  = minimum axial load, kN

$F_r$  = radial component of load for bearings subjected to combined load, kN

$C_0$  = basic static load rating, kN

$A$  = minimum load factor (→ product table)

$n$  = rotational speed, r/min

If  $1,8 F_r < 0,0005 C_0$  then  $0,0005 C_0$  should be used in the above equation instead of  $1,8 F_r$ .

At speeds higher than the reference speed or when starting up at low temperatures, or when the lubricant is highly viscous, even greater minimum loads may be required. The weight of the components supported by the bearing, together with external forces, generally exceed the requisite minimum load. If this is not the case, the spherical roller thrust bearing must be preloaded, e.g. by use of springs.

However, when a spherical roller thrust bearing is radially guided and mounted with clearance, the axial minimum load can be reduced under certain conditions. Contact the SKF application engineering service for advice.

## Supplementary designations

The designation suffixes often used to identify certain features of SKF spherical roller thrust bearings are explained in the following.

<b>E</b>	Optimized internal design, window-type steel cage
<b>EF</b>	Optimized internal design, machined steel cage
<b>EM</b>	Optimized internal design, machined brass cage
<b>N1</b>	One locating slot in the housing washer
<b>N2</b>	Two locating slots slots, 180° apart, in the housing washer
<b>VE447</b>	Shaft washer with three equally spaced threaded holes in one side face to take hoisting tackle
<b>VE447E</b>	As VE447, but with three appropriate eye bolts
<b>VE632</b>	Housing washer with three equally spaced threaded holes in one side face to take hoisting tackle
<b>VU029</b>	Internal design feature for bearings operating under combined loads without any spring loading and adjusted to a specific axial clearance

Spherical roller thrust bearings  
d 60 – 190 mm

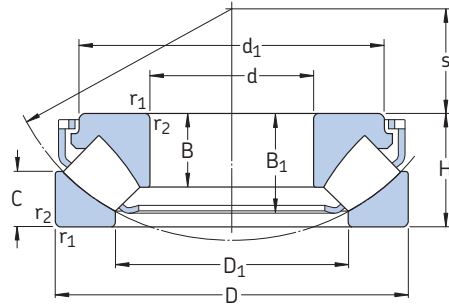

Principal dimensions			Basic load ratings		Fatigue load limit $P_u$	Minimum load factor $A$	Speed ratings		Mass	Designation
d	D	H	dynamic C	static $C_0$			Reference speed	Limiting speed		
mm			kN		kN	–	r/min	kg	–	
60	130	42	390	915	114	0,080	2 800	5 000	2,20	29412 E
65	140	45	455	1 080	137	0,11	2 600	4 800	3,20	29413 E
70	150	48	520	1 250	153	0,15	2 400	4 300	3,90	29414 E
75	160	51	600	1 430	173	0,19	2 400	4 000	4,70	29415 E
80	170	54	670	1 630	193	0,25	2 200	3 800	5,60	29416 E
85	150	39	380	1 060	129	0,11	2 400	4 000	2,75	29317 E
	180	58	735	1 800	212	0,31	2 000	3 600	6,75	29417 E
90	155	39	400	1 080	132	0,11	2 400	4 000	2,85	29318 E
	190	60	815	2 000	232	0,38	1 900	3 400	7,75	29418 E
100	170	42	465	1 290	156	0,16	2 200	3 600	3,65	29320 E
	210	67	980	2 500	275	0,59	1 700	3 000	10,5	29420 E
110	190	48	610	1 730	204	0,28	1 900	3 200	5,30	29322 E
	230	73	1 180	3 000	325	0,86	1 600	2 800	13,5	29422 E
120	210	54	765	2 120	245	0,43	1 700	2 800	7,35	29324 E
	250	78	1 370	3 450	375	1,1	1 500	2 600	17,5	29424 E
130	225	58	865	2 500	280	0,59	1 600	2 600	9,00	29326 E
	270	85	1 560	4 050	430	1,6	1 300	2 400	22,0	29426 E
140	240	60	980	2 850	315	0,77	1 500	2 600	10,5	29328 E
	280	85	1 630	4 300	455	1,8	1 300	2 400	23,0	29428 E
150	215	39	408	1 600	180	0,24	1 800	2 800	4,30	29230 E
	250	60	1 000	2 850	315	0,77	1 500	2 400	11,0	29330 E
	300	90	1 860	5 100	520	2,5	1 200	2 200	28,0	29430 E
160	270	67	1 180	3 450	375	1,1	1 300	2 200	14,5	29332 E
	320	95	2 080	5 600	570	3	1 100	2 000	33,5	29432 E
170	280	67	1 200	3 550	365	1,2	1 300	2 200	15,0	29334 E
	340	103	2 360	6 550	640	4,1	1 100	1 900	44,5	29434 E
180	250	42	495	2 040	212	0,40	1 600	2 600	5,80	29236 E
	300	73	1 430	4 300	440	1,8	1 200	2 000	19,5	29336 E
	360	109	2 600	7 350	710	5,1	1 000	1 800	52,5	29436 E
190	320	78	1 630	4 750	490	2,1	1 100	1 900	23,5	29338 E
	380	115	2 850	8 000	765	6,1	950	1 700	60,5	29438 E

The designations of SKF Explorer bearings are printed in blue

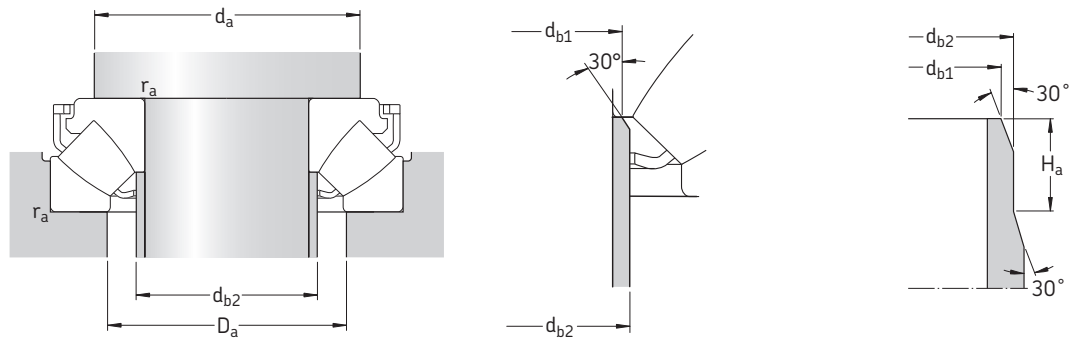

**Dimensions**

**Abutment and fillet dimensions**

d	$\underline{d}_1$	$\underline{D}_1$	B	$B_1$	C	$r_{1,2}$ min	s	$d_a$ min	$d_{b1}$ max	$d_{b2}$ max	$H_a$ min	$D_a$ max	$r_a$ max
mm								mm					
<b>60</b>	112,2	85,5	27	36,7	21	1,5	38	90	67	67	–	107	1,5
<b>65</b>	120,6	91,5	29,5	39,8	22	2	42	100	72	72	–	117	2
<b>70</b>	129,7	99	31	41	23,8	2	44,8	105	77,5	77,5	–	125	2
<b>75</b>	138,3	105,5	33,5	45,7	24,5	2	47	115	82,5	82,5	–	133	2
<b>80</b>	147,2	112,5	35	48,1	26,5	2,1	50	120	88	88	–	141	2
<b>85</b>	134,8 155,8	109,5 121	24,5 37	33,8 51,1	20 28	1,5 2,1	50 54	115 130	90 94	90 94	– –	129 151	1,5 2
<b>90</b>	138,6 164,6	115 127,5	24,5 39	34,5 54	19,5 28,5	1,5 2,1	53 56	120 135	95 99	95 99	– –	134 158	1,5 2
<b>100</b>	152,3 182,2	127,5 141,5	26,2 43	36,3 57,3	20,5 32	1,5 3	58 62	130 150	107 110	107 110	– –	147 175	1,5 2,5
<b>110</b>	171,1 199,4	140 155,5	30,3 47	41,7 64,7	24,8 34,7	2 3	63,8 69	145 165	117 120,5	117 129	– –	164 193	2 2,5
<b>120</b>	188,1 216,8	154 171	34 50,5	48,2 70,3	27 36,5	2,1 4	70 74	160 180	128 132	128 142	– –	181 209	2 3
<b>130</b>	203,4 234,4	165,5 184,5	36,7 54	50,6 76	30,1 40,9	2,1 4	75,6 81	175 195	138 142,5	143 153	– –	194 227	2 3
<b>140</b>	216,1 245,4	177 194,5	38,5 54	54 75,6	30 41	2,1 4	82 86	185 205	148 153	154 162	– –	208 236	2 3
<b>150</b>	200,4 223,9 262,9	176 190 207,5	24 38 58	34,3 54,9 80,8	20,5 28 43,4	1,5 2,1 4	82 87 92	180 195 220	154 158 163	154 163 175	14 – –	193 219 253	1,5 2 3
<b>160</b>	243,5 279,3	203 223,5	42 60,5	60 84,3	33 45,5	3 5	92 99	210 235	169 175	176 189	– –	235 270	2,5 4
<b>170</b>	251,2 297,7	215 236	42,2 65,5	61 91,2	30,5 50	3 5	96 104	220 250	178 185	188 199	– –	245 286	2,5 4
<b>180</b>	234,4 270 315,9	208 227 250	26 46 69,5	36,9 66,2 96,4	22 35,5 53	1,5 3 5	97 103 110	210 235 265	187 189 196	187 195 210	14 – –	226 262 304	1,5 2,5 4
<b>190</b>	285,6 332,9	243,5 264,5	49 73	71,3 101	36 55,5	4 5	110 117	250 280	200 207	211 223	– –	280 321	3 4

# Spherical roller thrust bearings

d 200 – 420 mm

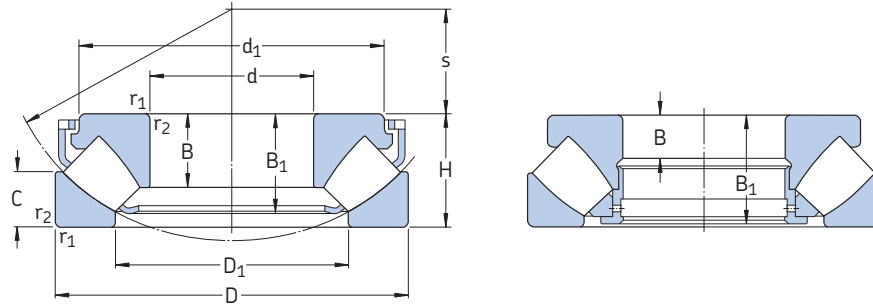

Principal dimensions			Basic load ratings		Fatigue load limit $P_u$	Minimum load factor A	Speed ratings		Mass	Designation
d	D	H	dynamic C	static $C_0$			Reference speed	Limiting speed		
mm			kN		kN	–	r/min	kg	–	
200	280	48	656	2 650	285	0,67	1 400	2 200	9,30	29240 E
	340	85	1 860	5 500	550	2,9	1 000	1 700	29,5	29340 E
	400	122	3 200	9 000	850	7,7	850	1 600	72,0	29440 E
220	300	48	690	3 000	310	0,86	1 300	2 200	10,0	29244 E
	360	85	2 000	6 300	610	3,8	1 000	1 700	33,5	29344 E
	420	122	3 350	9 650	900	8,8	850	1 500	75,0	29444 E
240	340	60	799	3 450	335	1,1	1 100	1 800	16,5	29248
	380	85	2 040	6 550	630	4,1	1 000	1 600	35,5	29348 E
	440	122	3 400	10 200	930	9,9	850	1 500	80,0	29448 E
260	360	60	817	3 650	345	1,3	1 100	1 700	18,5	29252
	420	95	2 550	8 300	780	6,5	850	1 400	49,0	29352 E
	480	132	4 050	12 900	1 080	16	750	1 300	105	29452 E
280	380	60	863	4 000	375	1,5	1 000	1 700	19,5	29256
	440	95	2 550	8 650	800	7,1	850	1 400	53,0	29356 E
	520	145	4 900	15 300	1 320	22	670	1 200	135	29456 E
300	420	73	1 070	4 800	465	2,2	900	1 400	30,5	29260
	480	109	3 100	10 600	930	11	750	1 200	75,0	29360 E
	540	145	4 310	16 600	1 340	26	600	1 200	140	29460 E
320	440	73	1 110	5 100	465	2,5	850	1 400	33,0	29264
	500	109	3 350	11 200	1 000	12	750	1 200	78,0	29364 E
	580	155	4 950	19 000	1 530	34	560	1 100	175	29464 E
340	460	73	1 130	5 400	480	2,8	850	1 300	33,5	29268
	540	122	2 710	11 000	950	11	600	1 100	105	29368
	620	170	5 750	22 400	1 760	48	500	1 000	220	29468 E
360	500	85	1 460	6 800	585	4,4	750	1 200	52,0	29272
	560	122	2 760	11 600	980	13	600	1 100	110	29372
	640	170	5 350	21 200	1 630	43	500	950	230	29472 EM
380	520	85	1 580	7 650	655	5,6	700	1 100	53,0	29276
	600	132	3 340	14 000	1 160	19	530	1 000	140	29376
	670	175	5 870	24 000	1 860	55	480	900	260	29476 EM
400	540	85	1 610	8 000	695	6,1	700	1 100	55,5	29280
	620	132	3 450	14 600	1 200	20	530	950	150	29380
	710	185	6 560	26 500	1 960	67	450	850	310	29480 EM
420	580	95	1 990	9 800	815	9,1	630	1 000	75,5	29284
	650	140	3 740	16 000	1 290	24	500	900	170	29384
	730	185	6 730	27 500	2 080	72	430	850	325	29484 EM

The designations of SKF Explorer bearings are printed in blue

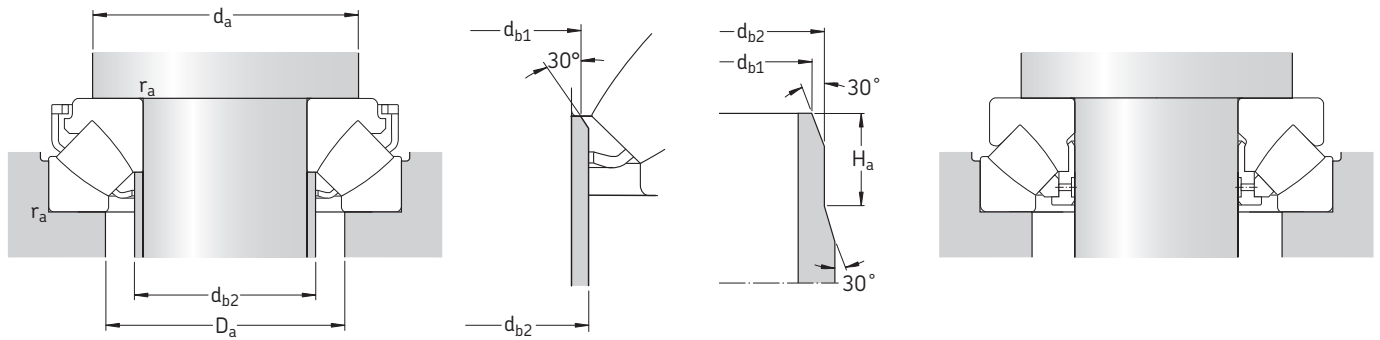

**Dimensions**

**Abutment and fillet dimensions**

d	$\underline{d}_1$	$\underline{D}_1$	B	$B_1$	C	$r_{1,2}$ min	s	$\underline{d}_a$ min	$\underline{d}_{b1}$ max	$\underline{d}_{b2}$ max	$\underline{H}_a$ min	$\underline{D}_a$ max	$\underline{r}_a$ max
mm								mm					
200	260,5	232,5	30	43,4	24	2	108	235	206	207	17	253	2
	304,3	257	53,5	76,7	40	4	116	265	211	224	–	297	3
	350,7	277,5	77	107,1	59,4	5	122	295	217,5	234	–	337	4
220	280,5	251,5	30	43,4	24,5	2	117	255	224,5	227	17	271	2
	326,3	273,5	55	77,7	41	4	125	285	229	240	–	316	3
	371,6	300	77	107,4	58,5	6	132	315	238	254	–	358	5
240	330	283	19	57	30	2,1	130	290	–	–	–	308	2
	345,1	295,5	54	77,8	40,5	4	135	305	249	259	–	336	3
	391,6	322	76	107,1	59	6	142	335	258	276	–	378	5
260	350	302	19	57	30	2,1	139	310	–	–	–	326	2
	382,2	324	61	86,6	46	5	148	335	273	286	–	370	4
	427,9	346	86	119	63	6	154	365	278	296	–	412	5
280	370	323	19	57	30,5	2,1	150	325	–	–	–	347	2
	401	343	62	86,7	45,5	5	158	355	293	305	–	390	4
	464,3	372	95	129,9	70	6	166	395	300	320	–	446	5
300	405	353	21	69	38	3	162	360	–	–	–	380	2,5
	434,1	372	70	98,9	51	5	168	385	313	329	–	423	4
	485	392	95	130,3	70,5	6	175	415	319	340	–	465	5
320	430	372	21	69	38	3	172	380	–	–	–	400	2,5
	454,5	391	68	97,8	53	5	180	405	332	347	–	442	4
	520,3	422	102	139,4	74,5	7,5	191	450	344	367	–	500	6
340	445	395	21	69	37,5	3	183	400	–	–	–	422	2,5
	520	428	40,6	117	59,5	5	192	440	–	–	–	479	4
	557,9	445	112	151,4	84	7,5	201	475	363	386	–	530	6
360	485	423	25	81	44	4	194,5	430	–	–	–	453	3
	540	448	40,5	117	59,5	5	202	460	–	–	–	500	4
	580	474	63	164	83,5	7,5	210	495	–	–	–	550	6
380	505	441	27	81	42	4	202	450	–	–	–	473	3
	580	477	45	127	63,5	6	216	495	–	–	–	535	5
	610	494	67	168	87,5	7,5	222	525	–	–	–	580	6
400	526	460	27	81	42,2	4	212	470	–	–	–	493	3
	596	494	43	127	64	6	225	510	–	–	–	550	5
	645	525	69	178	89,5	7,5	234	550	–	–	–	615	6
420	564	489	30	91	46	5	225	500	–	–	–	525	4
	626	520	49	135	67,5	6	235	535	–	–	–	580	5
	665	545	70	178	90,5	7,5	244	575	–	–	–	635	6

# Spherical roller thrust bearings

d 440 – 900 mm

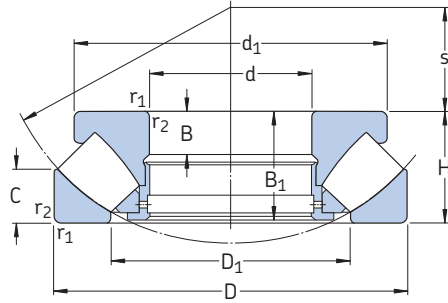

Principal dimensions			Basic load ratings		Fatigue load limit $P_u$	Minimum load factor $A$	Speed ratings		Mass	Designation
d	D	H	dynamic C	static $C_0$			Reference speed	Limiting speed		
mm			kN		kN	–	r/min	kg	–	
440	600	95	2 070	10 400	850	10	630	1 000	78,0	29288
	680	145	4 490	19 300	1 560	35	480	850	180	29388 EM
	780	206	7 820	32 000	2 320	87	380	750	410	29488 EM
460	620	95	2 070	10 600	865	11	600	950	81,0	29292
	710	150	4 310	19 000	1 500	34	450	800	215	29392
	800	206	7 990	33 500	2 450	110	380	750	425	29492 EM
480	650	103	2 350	11 800	950	13	560	900	98,0	29296
	730	150	4 370	19 600	1 530	36	450	800	220	29396
	850	224	9 550	39 000	2 800	140	340	670	550	29496 EM
500	670	103	2 390	12 500	1 000	15	560	900	100	292/500
	750	150	4 490	20 400	1 560	40	430	800	235	293/500
	870	224	9 370	40 000	2 850	150	340	670	560	294/500 EM
530	710	109	3 110	15 300	1 220	22	530	850	115	292/530 EM
	800	160	5 230	23 600	1 800	53	400	750	270	293/530
	920	236	10 500	44 000	3 100	180	320	630	650	294/530 EM
560	750	115	2 990	16 000	1 220	24	480	800	140	292/560
	980	250	12 000	51 000	3 550	250	300	560	810	294/560 EM
600	800	122	3 740	18 600	1 460	33	450	700	170	292/600 EM
	900	180	7 530	34 500	2 600	110	340	630	405	293/600
	1 030	258	13 100	56 000	4 000	300	280	530	845	294/600 EM
630	850	132	4 770	23 600	1 800	53	400	670	210	292/630 EM
	950	190	8 450	38 000	2 900	140	320	600	485	293/630 EM
	1 090	280	14 400	62 000	4 150	370	260	500	1 040	294/630 EM
670	900	140	4 200	22 800	1 660	49	380	630	255	292/670
	1 150	290	15 400	68 000	4 500	440	240	450	1 210	294/670 EM
710	1 060	212	9 950	45 500	3 400	200	280	500	660	293/710 EM
	1 220	308	17 600	76 500	5 000	560	220	430	1 500	294/710 EF
750	1 000	150	6 100	31 000	2 320	91	340	560	325	292/750 EM
	1 120	224	9 370	45 000	3 050	190	260	480	770	293/750
	1 280	315	18 700	85 000	5 500	690	200	400	1 650	294/750 EF
800	1 060	155	6 560	34 500	2 550	110	320	530	380	292/800 EM
	1 180	230	9 950	49 000	3 250	230	240	450	865	293/800
	1 360	335	20 200	93 000	5 850	820	190	360	2 025	294/800 EF
850	1 120	160	6 730	36 000	2 550	120	300	500	425	292/850 EM
	1 440	354	23 900	108 000	7 100	1 100	170	340	2 390	294/850 EF
900	1 520	372	26 700	122 000	7 200	1 400	160	300	2 650	294/900 EF



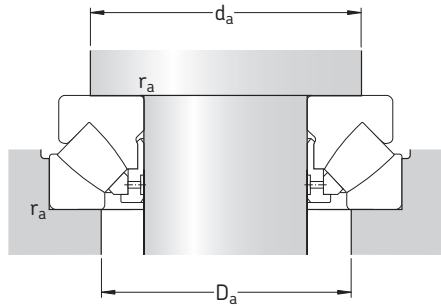

**Dimensions**
**Abutment and fillet dimensions**

d	$\tilde{d}_1$	$\tilde{D}_1$	B	$B_1$	C	$r_{1,2}$ min	s	$d_a$ min	$D_a$ max	$r_a$ max
								mm		
440	585	508	30	91	46,5	5	235	520	545	4
	626	540	49	140	70,5	6	249	560	605	5
	710	577	77	199	101	9,5	257	605	675	8
460	605	530	30	91	46	5	245	540	565	4
	685	567	50	144	72,5	6	257	585	630	5
	730	596	77	199	101,5	9,5	268	630	695	8
480	635	556	33	99	53,5	5	259	570	595	4
	705	591	50	144	73,5	6	270	610	655	5
	770	625	88	216	108	9,5	280	660	735	8
500	654	574	33	99	53,5	5	268	585	615	4
	725	611	50	144	74	6	280	630	675	5
	795	648	86	216	110	9,5	290	685	755	8
530	675	608	32	105	56	5	285	620	655	4
	772	648	53	154	76	7,5	295	670	715	6
	840	686	89	228	116	9,5	308	725	800	8
560	732	644	37	111	61	5	302	655	685	4
	890	727	99	241	122	12	328	770	850	10
	600	760	688	39	117	60	5	321	700	735
840		720	65	174	89	7,5	340	755	810	6
940		769	99	249	128	12	349	815	900	10
630	810	723	50	127	62	6	338	740	780	5
	880	761	68	183	92	9,5	359	795	860	8
	995	815	107	270	137	12	365	860	950	10
670	880	773	45	135	73	6	361	790	825	5
	1045	864	110	280	141	15	387	905	1000	12
	710	985	855	74	205	103	9,5	404	890	960
1110		917	117	298	149	15	415	965	1070	12
750		950	858	50	144	74	6	409	880	925
	1086	910	76	216	109	9,5	415	935	1000	8
	1170	964	121	305	153	15	436	1015	1120	12
800	1010	911	52	149	77	7,5	434	935	980	6
	1146	965	77	222	111	9,5	440	995	1060	8
	1250	1034	123	324	165	15	462	1080	1185	12
850	1060	967	47	154	82	7,5	455	980	1030	6
	1315	1077	142	342	172	15	507	1160	1270	12
	900	1394	1137	147	360	186	15	518	1215	1320

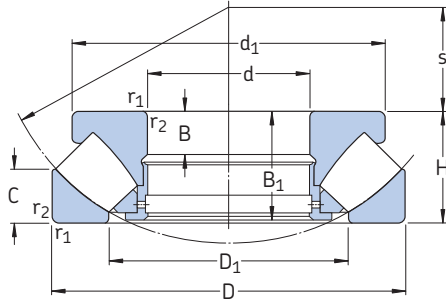
Spherical roller thrust bearings  
d 950 – 1 600 mm

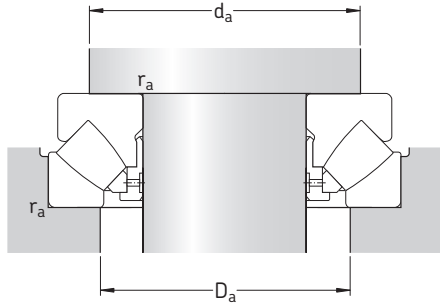

Principal dimensions			Basic load ratings		Fatigue load limit $P_u$	Minimum load factor $A$	Speed ratings		Mass	Designation
d	D	H	dynamic C	static $C_0$			Reference speed	Limiting speed		
mm			kN		kN	–	r/min		kg	–
<b>950</b>	1 250	180	8 280	45 500	3 100	200	260	430	600	<b>292/950 EM</b>
	1 600	390	28 200	132 000	7 800	1 700	140	280	3 065	<b>294/950 EF</b>
<b>1 000</b>	1 670	402	31 100	140 000	8 650	1 900	130	260	3 380	<b>294/1000 EF</b>
<b>1 060</b>	1 400	206	10 500	58 500	3 750	330	220	360	860	<b>292/1060 EF</b>
	1 770	426	33 400	156 000	8 500	2 300	120	240	4 280	<b>294/1060 EF</b>
<b>1 180</b>	1 520	206	10 900	64 000	3 750	390	220	340	950	<b>292/1180 EF</b>
<b>1 250</b>	1 800	330	24 800	129 000	7 500	1 600	130	240	2 770	<b>293/1250 EF</b>
<b>1 600</b>	2 280	408	36 800	200 000	11 800	3 800	90	160	5 375	<b>293/1600 EF</b>



**Dimensions**

**Abutment and fillet dimensions**

d	$d_1$	$D_1$	B	$B_1$	C	$r_{1,2}$ min	s	$d_a$ min	$D_a$ max	$r_a$ max
mm								mm		
<b>950</b>	1 185	1 081	58	174	88	7,5	507	1 095	1 155	6
	1 470	1 209	153	377	191	15	546	1 275	1 400	12
<b>1 000</b>	1 531	1 270	155	389	190	15	599	1 350	1 490	12
<b>1 060</b>	1 325	1 211	66	199	100	9,5	566	1 225	1 290	8
	1 615	1 349	192	412	207	15	610	1 410	1 555	12
<b>1 180</b>	1 450	1 331	83	199	101	9,5	625	1 345	1 410	8
<b>1 250</b>	1 685	1 474	148	319	161	12	698	1 540	1 640	10
<b>1 600</b>	2 130	1 885	166	395	195	19	894	1 955	2 090	15

# Related SKF products

## The right equipment

To achieve maximum bearing service life and optimum performance from SKF spherical roller thrust bearings, they must be mounted correctly.

SKF offers a comprehensive line of tools and equipment for mounting, dismantling and maintenance of bearings, e.g. a range of induction heaters, hydraulic pumps and nuts etc.

## Lubrication grease

High quality bearings need high quality grease. Extensive research, testing and field experience are behind the formulation of all SKF greases. And they have the same high quality wherever you are in the world.

The most commonly used SKF greases for spherical roller thrust bearings are listed in **tables 1 and 2 on page 27**.

## Special housing for ship propeller shafts

SKF offers a range of special housings for ship propeller-shaft supports. They are designed to accommodate a spherical roller bearing in combination with a spherical roller thrust bearing.

## Condition monitoring equipment

Properly dimensioned and mounted bearings are reliable components. For a number of applications, however, it is recommended to monitor the bearing condition, as to avoid unexpected breakdowns. These could happen, for example, when operating under adverse conditions.

Condition monitoring enables early detection of bearing damage, which means that bearing replacement can be scheduled when the machine is not in operation.

SKF supplies equipment for both periodic and continuous condition monitoring.

*SKF has a wide range of bearing lubrication greases in different packagings to suit different needs*





*SKF's handy general purpose electronic thermometer, ThermoPen TMTP 200*



*SKF's easy-to-use electronic stethoscope TMST 3 is an instrument to detect damaged bearings. The set includes a demonstration tape*



*SKF offers a large assortment of hydraulic tools to facilitate mounting and dismantling of rolling bearings*

# SKF – the knowledge engineering company

From the company that invented the self-aligning ball bearing more than 100 years ago, SKF has evolved into a knowledge engineering company that is able to draw on five technology platforms to create unique solutions for its customers. These platforms include bearings, bearing units and seals, of course, but extend to other areas including: lubricants and lubrication systems, critical for long bearing life in many applications; mechatronics that combine mechanical and electronics knowledge into systems for more effective linear motion and sensorized solutions; and a full range of services, from design and logistics support to condition monitoring and reliability systems.

Though the scope has broadened, SKF continues to maintain the world's leadership in the design, manufacture and marketing of rolling bearings, as well as complementary products such as radial seals. SKF also holds an increasingly important position in the market for linear motion products, high-precision aerospace bearings, machine tool spindles and plant maintenance services.

The SKF Group is globally certified to ISO 14001, the international standard for environmental management, as well as OHSAS 18001, the health and safety management standard. Individual divisions have been approved for quality certification in accordance with ISO 9001 and other customer specific requirements.

With over 100 manufacturing sites worldwide and sales companies in 70 countries, SKF is a truly international corporation. In addition, our distributors and dealers in some 15 000 locations around the world, an e-business marketplace and a global distribution system put SKF close to customers for the supply of both products and services. In essence, SKF solutions are available wherever and whenever customers need them. Overall, the SKF brand and the corporation are stronger than ever. As the knowledge engineering company, we stand ready to serve you with world-class product competencies, intellectual resources, and the vision to help you succeed.



© Airbus – photo: e'm company, H. Goussé

## **Evolving by-wire technology**

SKF has a unique expertise in the fast-growing by-wire technology, from fly-by-wire, to drive-by-wire, to work-by-wire. SKF pioneered practical fly-by-wire technology and is a close working partner with all aerospace industry leaders. As an example, virtually all aircraft of the Airbus design use SKF by-wire systems for cockpit flight control.

SKF is also a leader in automotive by-wire technology, and has partnered with automotive engineers to develop two concept cars, which employ SKF mechatronics for steering and braking. Further by-wire development has led SKF to produce an all-electric forklift truck, which uses mechatronics rather than hydraulics for all controls.

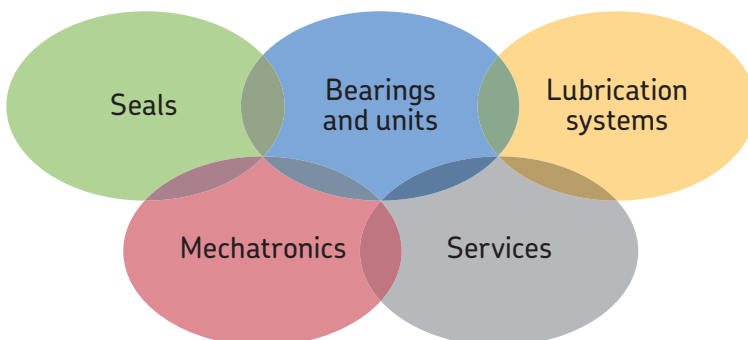



#### **Harnessing wind power**

The growing industry of wind-generated electric power provides a source of clean, green electricity. SKF is working closely with global industry leaders to develop efficient and trouble-free turbines, providing a wide range of large, highly specialized bearings and condition monitoring systems to extend equipment life of wind farms located in even the most remote and inhospitable environments.



#### **Working in extreme environments**

In frigid winters, especially in northern countries, extreme sub-zero temperatures can cause bearings in railway axleboxes to seize due to lubrication starvation. SKF created a new family of synthetic lubricants formulated to retain their lubrication viscosity even at these extreme temperatures. SKF knowledge enables manufacturers and end user customers to overcome the performance issues resulting from extreme temperatures, whether hot or cold. For example, SKF products are at work in diverse environments such as baking ovens and instant freezing in food processing plants.



#### **Developing a cleaner cleaner**

The electric motor and its bearings are the heart of many household appliances. SKF works closely with appliance manufacturers to improve their products' performance, cut costs, reduce weight, and reduce energy consumption. A recent example of this cooperation is a new generation of vacuum cleaners with substantially more suction. SKF knowledge in the area of small bearing technology is also applied to manufacturers of power tools and office equipment.



#### **Maintaining a 350 km/h R&D lab**

In addition to SKF's renowned research and development facilities in Europe and the United States, Formula One car racing provides a unique environment for SKF to push the limits of bearing technology. For over 60 years, SKF products, engineering and knowledge have helped make Scuderia Ferrari a formidable force in F1 racing. (The average racing Ferrari utilizes around 150 SKF components.) Lessons learned here are applied to the products we provide to automakers and the aftermarket worldwide.



#### **Delivering Asset Efficiency Optimization**

Through SKF Reliability Systems, SKF provides a comprehensive range of asset efficiency products and services, from condition monitoring hardware and software to maintenance strategies, engineering assistance and machine reliability programmes. To optimize efficiency and boost productivity, some industrial facilities opt for an Integrated Maintenance Solution, in which SKF delivers all services under one fixed-fee, performance-based contract.



#### **Planning for sustainable growth**

By their very nature, bearings make a positive contribution to the natural environment, enabling machinery to operate more efficiently, consume less power, and require less lubrication. By raising the performance bar for our own products, SKF is enabling a new generation of high-efficiency products and equipment. With an eye to the future and the world we will leave to our children, the SKF Group policy on environment, health and safety, as well as the manufacturing techniques, are planned and implemented to help protect and preserve the earth's limited natural resources. We remain committed to sustainable, environmentally responsible growth.



© SKF, @PTITUDE, WAVE and MARLIN are registered trademarks of the SKF Group.  
™ SKF EXPLORER and TOTAL SHAFT SOLUTION are trademarks of the SKF Group.

© SKF Group 2010  
The contents of this publication are the copyright of the publisher and may not be reproduced (even extracts) unless prior written permission is granted. Every care has been taken to ensure the accuracy of the information contained in this publication but no liability can be accepted for any loss or damage whether direct, indirect or consequential arising out of the use of the information contained herein.

**PUB BU/P2 06104/1 EN** · June 2010

Printed in Sweden on environmentally friendly paper.

[skf.com](http://skf.com)