

Rod ends for the food industry



Maintenance-free plain bearing solutions from SKF

- Corrosion resistant
- Low friction
- Cost-effective



Corrosion resistant, maintenance-free and designed for frequent wash downs

The food and beverage processing industries have unique requirements. Depending on the application, equipment has to withstand hot, cold or wet environments and has to be able to withstand

- frequent wash downs
- exposure to harsh cleaning agents
- food and liquid contaminants
- a variety of chemicals.

To deal with these challenging operating conditions, specially designed components have to be used.

To provide bearing solutions that will meet these challenges, SKF has introduced two lines of maintenance-free rod ends, providing exceptional corrosion resistance, food and beverage compatibility and long service life.

SKF food line rod ends

There are three different series of SKF food line rod ends. The SRIKB and SRAKB series are characterized by a stainless steel rod end housing while rod ends in the lightweight SFIK series use a composite housing. All rod ends are equipped with a stainless steel inner ring and a PTFE composite dry sliding layer.

High performance sliding contact surfaces

The sphered counter surface of the stainless steel inner ring (X105CrMo17 to EN 10088-1:1995 or AISI 440 C) is ground and polished. The dry sliding layer made of glass fibre reinforced polyamide containing PTFE is injection moulded between the rod end housing and inner ring.

This sliding contact surface combination provides low friction and good wear resistance.

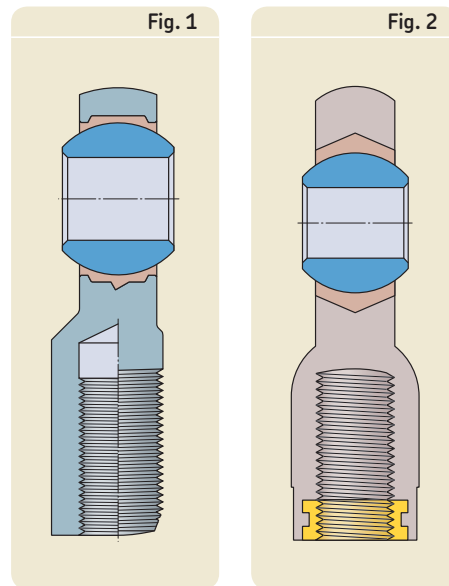

Rod end with stainless steel housing

Rod end with composite housing

Operating temperature ranges

SKF's food line of rod ends can be used at temperatures from -40 to $+75$ °C (-40 to $+170$ °F). However, if the load carrying capacity is fully exploited, the maximum temperature has to be limited to $+50$ °C ($+120$ °F).

Rod ends with a stainless steel housing

Rod ends with a stainless steel housing are available with

- female thread, SRI(L)KB .. FG series (→ fig. 1)
- male thread, SRA(L)KB .. FG series (→ fig. 1)

with the choice between right or left hand thread.



The rod end housings are made of X17CrNi16-2 stainless steel (EN 10088-1:1995 or AISI 431) and have polished outside surfaces to improve corrosion resistance and facilitate wash downs.

These rod ends provide excellent performance where alignment movements have to be accommodated in a difficult environment.

Rod ends with a composite housing

Rod ends with a composite housing are available with

- female thread, SFIK .. FG series (→ fig. 2)

with the choice between a right or left hand thread.

These lightweight rod end housings are made of a glass fibre reinforced polyamide incorporating a stainless steel threaded insert. The non-porous outside surfaces facilitate wash downs.

These rod ends provide excellent performance where alignment movements and moderate loads must be accommodated in a difficult environment.

Maintenance-free rod ends with a stainless steel housing and sliding contact surface
 combination stainless steel/PTFE composite
 d 5 – 20 mm

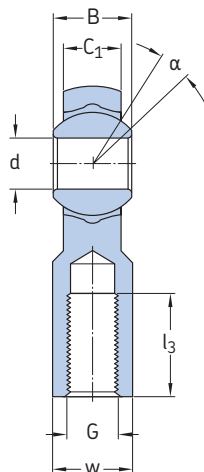

SRI(L)KB .. FG

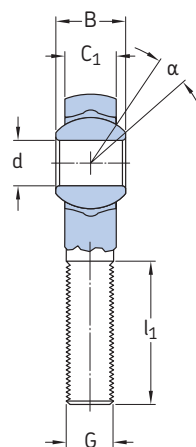

SRA(L)KB .. FG

Dimensions												Angle of tilt	Basic load ratings		Mass	Designations			
d	d ₂ max	G 6H	B	C ₁ max	h ₁	d ₄	l ₃	l ₄	l ₇	w	α		C	C ₀		dynamic	static	Rod end with right-hand female thread	left-hand female thread
mm												deg.	kN		kg	-			
5	18	M 5	8	6	27	11	10	36	11	9	13	3,25	5,3	0,019	SRIKB 5 FG	SRILKB 5 FG			
6	20	M 6	9	6,75	30	13	12	40	12	11	13	4,25	6,8	0,028	SRIKB 6 FG	SRILKB 6 FG			
8	24	M 8	12	9	36	16	16	48	13,5	14	14	7,1	11,4	0,047	SRIKB 8 FG	SRILKB 8 FG			
10	29	M 10	14	10,5	43	19	20	57,5	16	17	13	9,8	14,3	0,079	SRIKB 10 FG	SRILKB 10 FG			
12	34	M 12	16	12	50	22	22	67	19	19	13	13,2	17	0,12	SRIKB 12 FG	SRILKB 12 FG			
14	37	M 14	19	13,5	57	26	25	75,5	18,5	22	16	17	27,5	0,16	SRIKB 14 FG	SRILKB 14 FG			
16	43	M 16	21	14,7	64	28	28	85,5	21,5	22	15	21,4	34,5	0,23	SRIKB 16 FG	SRILKB 16 FG			
18	47	M 18x1,5	23	16,5	71	31	32	94,5	24	27	15	26	41,5	0,33	SRIKB 18 FG	SRILKB 18 FG			
20	50	M 20x1,5	25	18	77	34	33	102	29	30	14	31	50	0,38	SRIKB 20 FG	SRILKB 20 FG			

Dimensions												Angle of tilt	Basic load ratings		Mass	Designations			
d	d ₂ max	G 6g	B	C ₁ max	h	l ₁	l ₂	α	C	C ₀	dynamic		static	Rod end with right-hand male thread		left-hand male thread			
mm												deg.	kN		kg	-			
5	18	M 5	8	6	33	19	42	13	3,25	5,3	0,015	5,3	SRAKB 5 FG	SRALKB 5 FG					
6	20	M 6	9	6,75	36	21	46	13	4,25	6,8	0,021	6,8	SRAKB 6 FG	SRALKB 6 FG					
8	24	M 8	12	9	42	25	54	14	7,1	10	0,035	10	SRAKB 8 FG	SRALKB 8 FG					
10	29	M 10	14	10,5	48	28	62,5	13	9,8	12,5	0,059	12,5	SRAKB 10 FG	SRALKB 10 FG					
12	34	M 12	16	12	54	32	71	13	13,2	15	0,1	15	SRAKB 12 FG	SRALKB 12 FG					
14	37	M 14	19	13,5	60	36	78,5	16	17	25,5	0,13	25,5	SRAKB 14 FG	SRALKB 14 FG					
16	43	M 16	21	14,7	66	37	87,5	15	21,4	34,5	0,2	34,5	SRAKB 16 FG	SRALKB 16 FG					
18	47	M 18x1,5	23	16,5	72	41	95,5	15	26	41,5	0,26	41,5	SRAKB 18 FG	SRALKB 18 FG					
20	50	M 20x1,5	25	18	78	45	103	14	31	50	0,37	50	SRAKB 20 FG	SRALKB 20 FG					

**Maintenance-free rod ends with a composite housing
and sliding contact surface combination stainless steel/PTFE composite**
d 5 – 12 mm

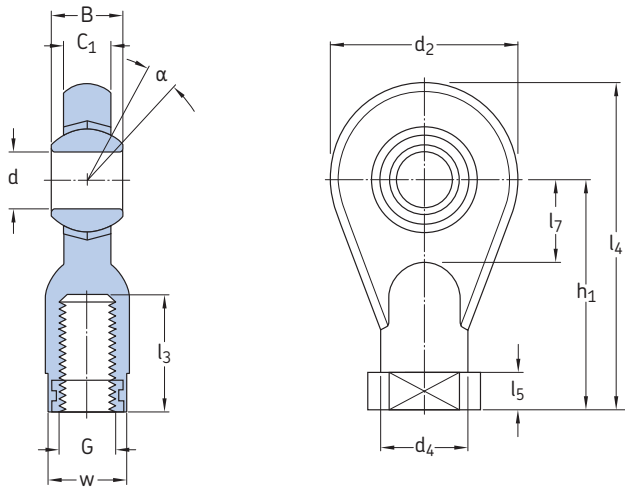

Dimensions													Angle of tilt		Basic load ratings		Mass	Designations	
d	d ₂ max	G	B	C ₁ max	h ₁	d ₄	l ₃	l ₄	l ₅	l ₇	w	α	C	C ₀		Rod end with right-hand female thread	left-hand female thread		
mm													deg.	kN		kg	–		
5	19	M 5	8	6	27	9	15	36,5	4	9	9	13	1,4	2	0,007	SFIK 5 FG	SFILK 5 FG		
6	25	M 6	9	6,75	30	11	17	42,5	5	11,5	11	13	1,8	2,55	0,011	SFIK 6 FG	SFILK 6 FG		
8	31	M 8	12	9	36	14,5	19	51,5	6	13,8	14	14	3	4,3	0,021	SFIK 8 FG	SFILK 8 FG		
10	36	M 10	14	10,5	43	18	22	61	6,5	17	17	13	4,15	6	0,035	SFIK 10 FG	SFILK 10 FG		
12	42	M 12	16	12	50	20	27	71	8	20	19	13	5,6	8	0,054	SFIK 12 FG	SFILK 12 FG		

For additional sizes please consult the SKF engineering application service.

® SKF is a registered trademark of the SKF Group.

© SKF Group 2007

The contents of this publication are the copyright of the publisher and may not be reproduced (even extracts) unless permission is granted. Every care has been taken to ensure the accuracy of the information contained in this publication but no liability can be accepted for any loss or damage whether direct, indirect or consequential arising out of the use of the information contained herein.

Publication **5419 EN/I** · Mars 2007

Printed in Sweden on environmentally friendly paper.