

K16-B

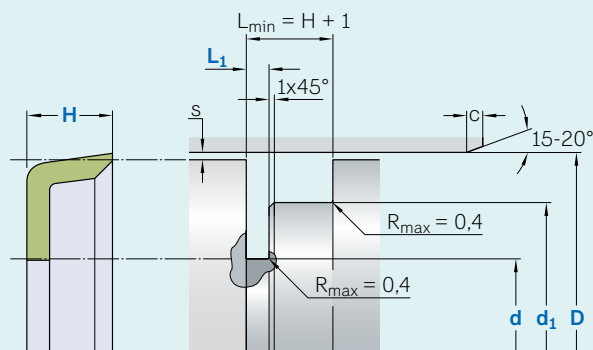

Ordering dimensions in **blue**

Surface roughness	R_{tmax}	R_a
	μm	
Sliding surface	$\leq 2,5$	0,05–0,2
Bottom of groove	$\leq 6,3$	$\leq 1,6$
Groove face	≤ 15	≤ 3

Bearing area: 50–95% and a cutting depth of 0,5 R_z based on $C_{ref} = 0\%$

Standard dimensions

This is not a standard profile and serves as a replacement seal to fit existing housings. New constructions should use standard profiles.

Ordering example

Profile
 $D \times d/d_1 \times L_1/H$ [mm]
 Sealing material

Piston seal K16-B
 58 x 40/49 x 3/12
 ECOPUR

Operating parameters

Material Seal	Temperature		Speed ¹⁾ linear max	Pressure ²⁾ linear max
	from	to		
	°C		m/s	bar (MPa)
■ ECOPUR	-30	+110	0,5	160 (16)
■ ECOPUR LD	-35	+110	0,5	160 (16)
■ G-ECOPUR	-30	+110	0,5	160 (16)
■ H-ECOPUR	-20	+110	0,5	160 (16)
■ S-ECOPUR	-20	+110	0,5	160 (16)
■ T-ECOPUR	-50	+110	0,5	160 (16)
■ SKF Ecorubber-1	-30	+100	0,5	160 (16)
■ SKF Ecorubber-H	-25	+150	0,5	160 (16)
■ SKF Ecorubber-2	-20	+200	0,5	160 (16)
■ SKF Ecorubber-3	-50	+150	0,5	160 (16)
■ SKF Ecoflas	-10	+200	0,5	160 (16)

IMPORTANT NOTE: The stated operating conditions represent general indications. It is recommended not to use all maximum values simultaneously.

¹⁾ Surface speed limit values are valid only in the presence of a lubrication film.

²⁾ Pressure ratings depend on the size of the extrusion gap.