

K23-H

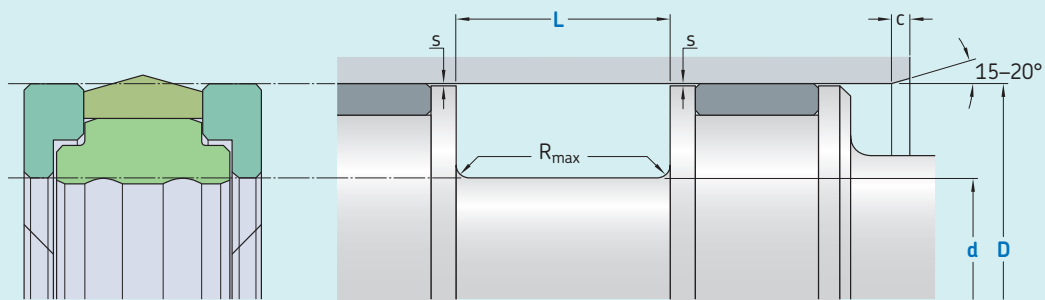

Ordering dimensions in **blue**

Surface roughness	R_{tmax}	R_a
	μm	
Sliding surface	$\leq 2,5$	0,05–0,2
Bottom of groove	$\leq 6,3$	$\leq 1,6$
Groove face	≤ 15	≤ 3

Bearing area: 50–95% and a cutting depth of 0,5 R_z based on $C_{ref} = 0\%$

Standard dimensions

D	d	L	R_{max}	c	s^*
H9	h9	+ 0,2			
over	incl.				1500 bar
mm					
20	50	D – 10	12,5	0,4	0,4
50	80	D – 15	20,0	0,4	0,4
80	150	D – 20	25,0	0,4	0,4
150	400	D – 25	32,0	0,4	0,4
400	600	D – 30	36,0	0,4	0,4

* Extrusion gap values shown above are valid for a temperature of 70 °C, higher temperatures require lower values.

Ordering example

Profile
 D x d x L [mm]
 Sealing material / Energizer / Back-up ring

Piston seal K23-H
 100 x 80 x 25
 ECOPUR / SKF Ecorubber-1 / SKF Ecotal

Operating parameters

Material Seal	Energizer	Back-up ring ³⁾	Temperature		Speed ¹⁾	Pressure ²⁾
			from	to	max	max
			°C		m/s	bar (MPa)
■ ECOPUR	■ SKF Ecorubber-1	■ SKF Ecotal	-30	+100	0,3	1 500 (150)
■ ECOPUR	■ SKF Ecorubber-1	■ SKF Ecomid	-30	+100	0,3	1 500 (150)
■ H-ECOPUR	■ SKF Ecorubber-1	■ SKF Ecotal	-30	+100	0,3	1 500 (150)
■ H-ECOPUR	■ SKF Ecorubber-1	■ SKF Ecomid	-30	+100	0,3	1 500 (150)
■ S-ECOPUR	■ SKF Ecorubber-1	■ SKF Ecotal	-30	+100	0,3	1 500 (150)
■ S-ECOPUR	■ SKF Ecorubber-1	■ SKF Ecomid	-30	+100	0,3	1 500 (150)
■ T-ECOPUR	■ SKF Ecosil	■ SKF Ecotal	-60	+100	0,3	1 500 (150)
■ T-ECOPUR	■ SKF Ecosil	■ SKF Ecomid	-60	+100	0,3	1 500 (150)

IMPORTANT NOTE: The stated operating conditions represent general indications. It is recommended not to use all maximum values simultaneously.

¹⁾ Surface speed limit values are valid only in the presence of a lubrication film.

²⁾ Pressure ratings depend on the size of the extrusion gap.

³⁾ Size limitation D: Up to 260 mm SKF Ecotal, from 260 – 400 mm SKF Ecotal or SKF Ecomid and above 400 mm SKF Ecomid.

