



# Lincoln Spray systems, chain lubrication and specialty systems



**LINCOLN**

# People, capabilities and systems to save resources and increase productivity

## Industry leader

Continually satisfying our customers with the world's best lubrication equipment and pumping systems has made Lincoln the largest and most successful company in our field. For nearly a century, companies have relied on our technical and quality leadership; our world-class manufacturing and customer service, and our vast network of distributors and support facilities.

## Research development

In order to provide the best worldwide and regional application solutions. Lincoln develops new products and systems at research and development facilities in the United States, Germany and India.

## Providing solutions

Industrial customers in large processing plants, automotive manufacturing, pulp and paper mills, food and beverage and other manufacturing facilities can depend on solutions from Lincoln. For the toughest mobile applications, on the road or in the field, Lincoln protects heavy equipment used in mining, construction, agriculture and over-the-road trucking. In addition, Lincoln offers the best lubrication equipment to meet the needs of automotive service professionals.

## Complete product line

Lincoln supplies automated lubrication systems, pumps and pump stations and top quality lubrication equipment and accessories. Our quality systems in the Czech Republic, Germany, India and United States are ISO 9001 registered. Additionally, our production sites in Czech Republic and Germany are ISO 14001 registered.

## Worldwide support

With five technical support centers on three continents, and a network of distributors supported by regional sales and service offices, our customers can always draw on our worldwide resources.

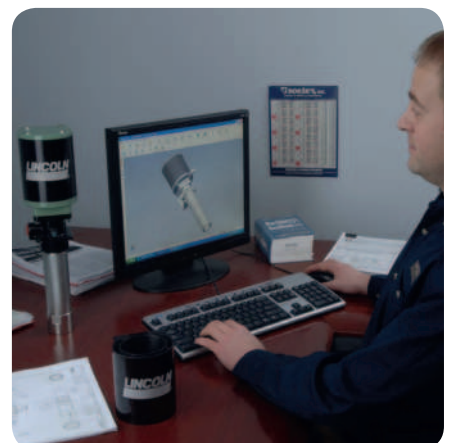
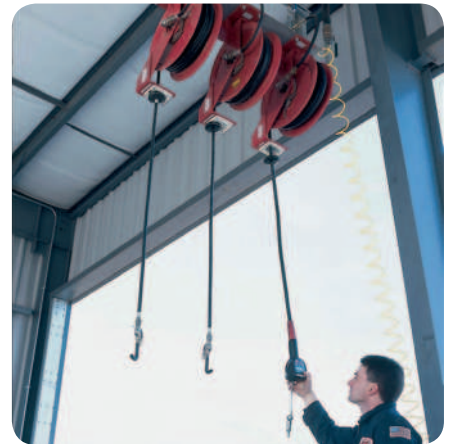

# Table of Contents

## Spray Systems

Schematic Spray System	4 - 5
SAF Pumps	6 - 7
Spray Nozzles	8
Accessories	9 - 10

## Chain Lubrication

EOS Single-line Oil System	10 - 11
Contact Lubrication	12
Brush Lubrication	13
Centro-Matic	14
PMA 2 Solenoid Pump	15 - 16
ORSCO	17
Cobra Chain Lubricator	18

## Speciality systems

CRL 101 Rail and Wheel Flange Lubrication	19
Hydrostatic Bearing Lubrication (Oil)	20
Supply Systems	21

# Spray Lubrication Systems

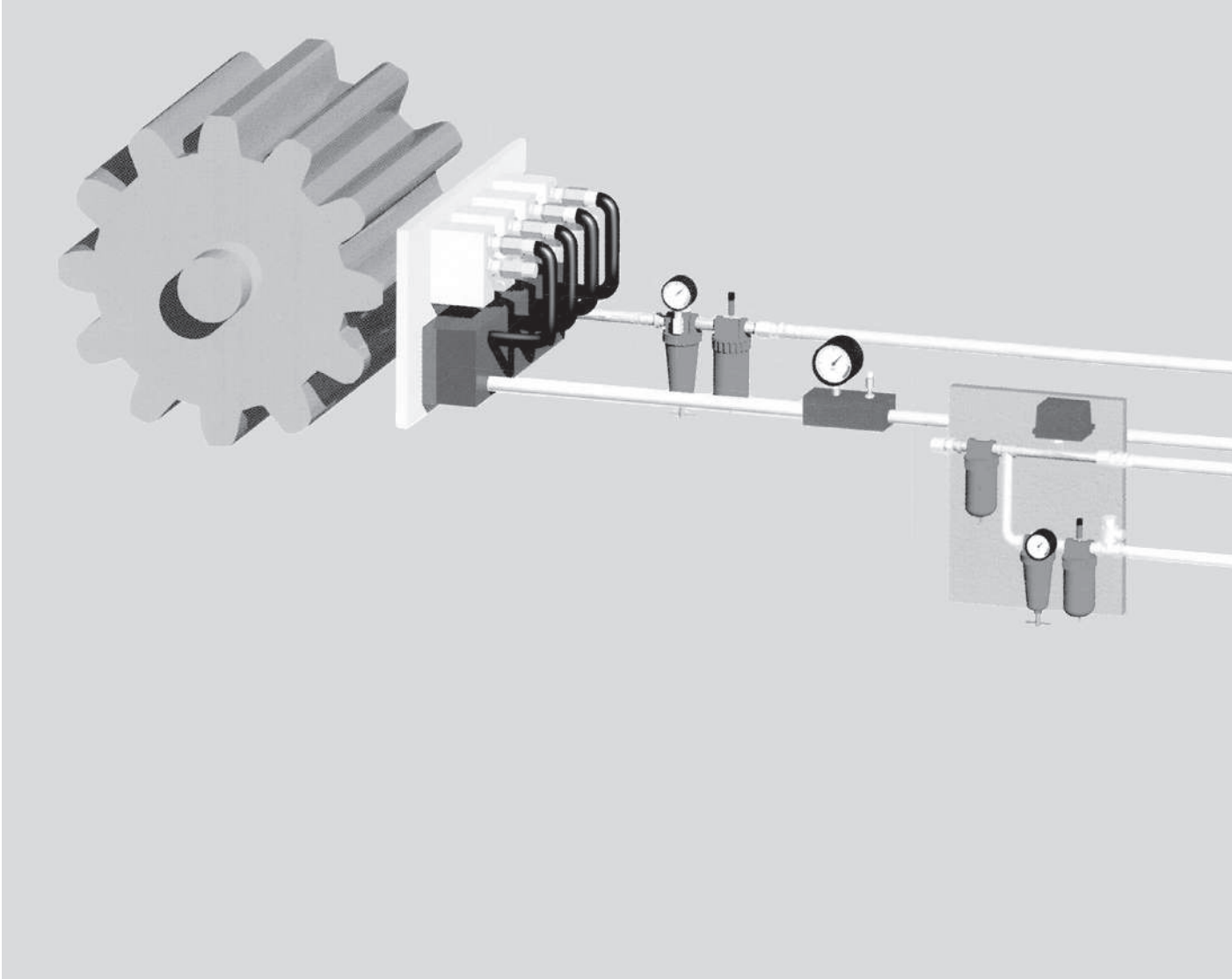

*Schematic Spray System*

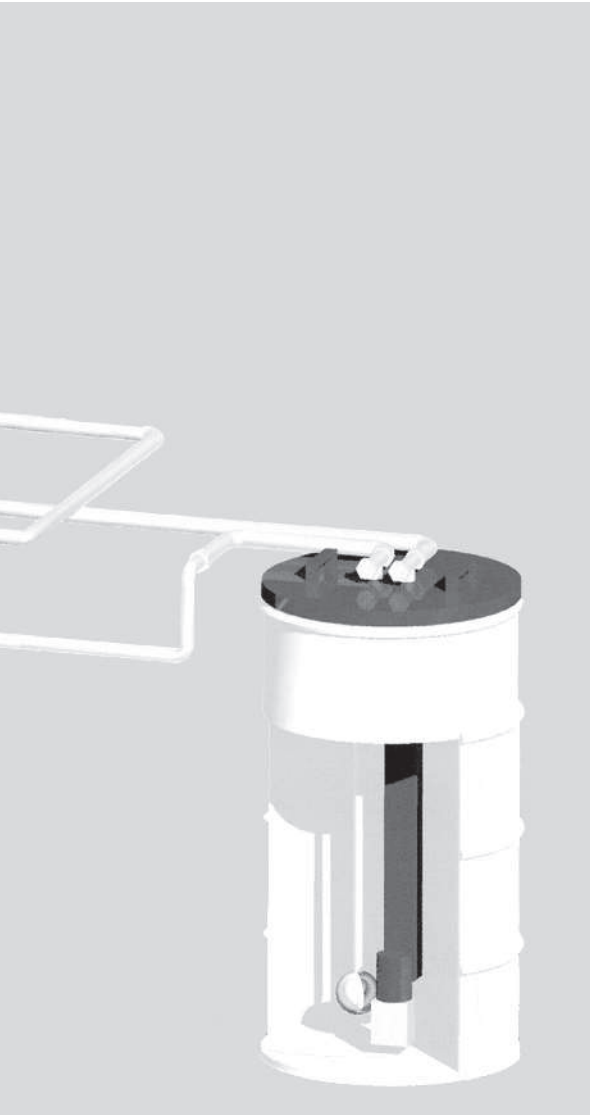

#### **Applications**

- Pinion lubrication
- Open gears

#### **Industries**

Cement, mills, pulp and paper

Spray systems use compressed air to spray the lubricant delivered by the pump on parts sliding against one another or rolling across one another.

#### **Common Components**

- Pumps

215 electric pump\*

- SAF and Lubrigun pneumatic pumps
- Ejectors (mini pneumatic pump)\*\*

#### **Nozzles**

- HSA wide-angle spray nozzles

#### **Capabilities**

- Controlled nozzles provide 100% monitoring of air-flow and lubricant supply as opposed to air pressure and lubricant flow
- Repeatability of spray pattern
- Complete air control possibility to reduce consumption

\* see *Progressive & Multi-line catalogue*

\*\* *not covered in this catalogue – ask your Lincoln representative for details*



# SAF Pumps



SAF1-YL



SAF Pump with Stand and Winch  
(Drum Supplied by Lubricant Supplier)

These pneumatic barrel pumps, SAF1-YL with one outlet and SAF2-YL with two outlets are designed for use in spray systems for the supply of adhesive lubricants (NLGI 0 and 00). SAF pumps are placed directly into 200 liter drums. They do not require a follower plate, thus the supply of lubricant is possible even if the drum is severely dented. With the aid of an optional stand and winch unit, it is easy to exchange barrels.

## Models

Part No.	Description	Number of Outlets	Lubricant Output/Stroke	Low-level
615-26392-3	SAF1-YN	1	1,1 cm <sup>3</sup>	no
615-26393-4	SAF1-YL	1	1,1 cm <sup>3</sup>	yes
615-26394-3	SAF2-YN	2	2 x 1,1 cm <sup>3</sup>	no
615-26395-4	SAF2-YL	2	2 x 1,1 cm <sup>3</sup>	yes

## Technical Data

maximum operating pressure	300 bar (4350 psi)
driving pressure	minimum 4 bar (58 psi) maximum 10 bar (145 psi)
air inlet connection	1/4 NPT female
pneumatic drive ratio	40:1
sound level	< 70 dB(A)
lubricant outlet	G 1/4 f (BSPP)
drum type	for 200 l lidded barrels acc. to DIN 6644
dimensions (L x W x H)	610 x 610 x 985 mm (24 x 24 x 38.8 in)

Note: A 3/2 way air solenoid valve is required.

## Accessories

Part No.	Description
615-26739-1	stand with winch for SAF1 (1 pinion drive) with air maintenance unit (FLR), pressure relief valve, air hoses and lubricant hoses
615-26740-1	stand with winch for SAF2 (2 pinion drive) with air maintenance unit (FLR), 2 pressure relief valves, air hoses and lubricant hoses
515-30955-1	overpressure valve (120 bar) manifold with pressure gauge

# Example: Stand with Winch for SAF2

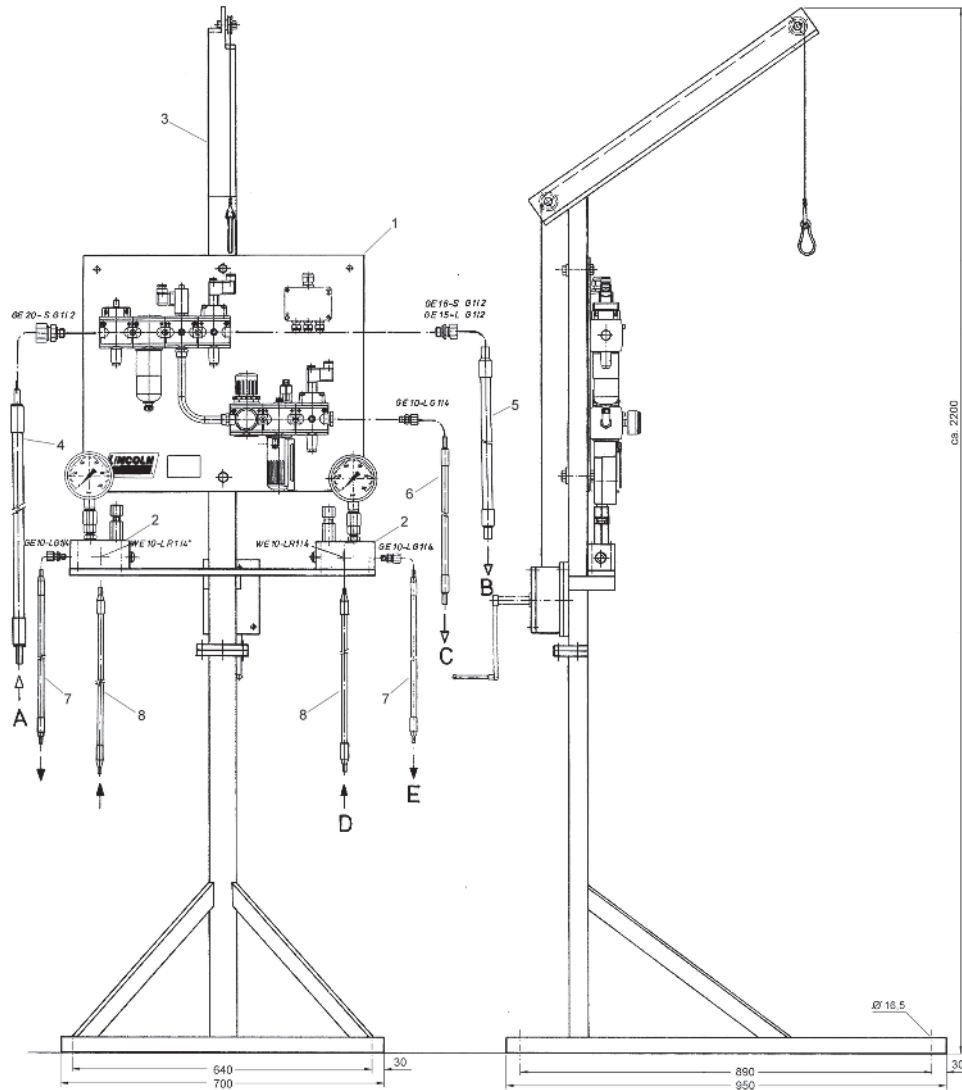

Dimensions (L x B x H): 950 x 700 x 2200 mm

## Item Designation

- A** compressed air from compressor
- B** compressed air to pump
- C** compressed air to spray unit
- D** lubricant from pump
- E** lubricant to spray unit

## Item Designation

- 1** maintenance unit
- 2** pressure relief device HSA-TD21
- 3** stand with winch
- 4** low-pressure hose OD 16 x 1040 mm with 20 mm stud
- 5** high-pressure hose OD 6 x 1540 mm with 10 mm stud
- 6** low-pressure hose OD 13 x 1040 mm with 15 mm stud
- 7** high-pressure hose OD 8 x 1040 mm with 10 mm stud
- 8** high-pressure hose OD 8 x 1540 mm with 10 mm stud

# Spray Nozzles

Lincoln spray nozzles are designed for the spraying of adhesive lubricants on pinions and open gears. The nozzles are available in several versions that cover a wide range of applications and functional features. The SDLKR series are the only nozzles that can monitor both the flow of air and lubricant within the nozzle. The economically priced SD series can be monitored externally by means of a progressive metering device and



SD (HSA-TD2)

the air can be controlled with an air solenoid valve. Complete mounting plates are available for easy alignment.

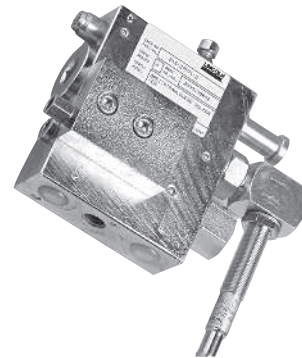

SDLKR (HSA-TD26)

## Nozzle Selection Guide & Part Numbers

Mounting Style	Uncontrolled Nozzles	Controlled Nozzles		
		without Monitoring	with Monitoring Limit Switch (15-250 VAC)	with Monitoring Proximity Switch (15-250 VAC)
mounting plate	HSA-TD2	HSA-TD27	HSA-TD25	HSA-TD26
	SD	SDLMNR	SDLMKR-ES	SDLMKR-EN
	part no. 615-25677-2	part no. 615-27519-2	part no. 615-27518-2	part no. 615-27571-2
single mounted nozzle (for brackets)	HSA-TD2	HSA-TD30	HSA-TD28	HSA-TD29
	SD	SDLHNR-G	SDLHKR-ESG	SDLHKR-ENG
	part no. 615-25677-2	part no. 615-27583-2	part no. 615-27585-2	part no. 615-27586-2

## Technical Data

lubricant output	0.2 – 20 cm <sup>3</sup> (0.0122 – 1.22 in <sup>3</sup> ) per minute		
spray surface coverage	approx. 150 mm (6.0 in) wide and 80 mm (3.3 in) high		
mounting distance	150 – 200 mm (6 – 8 in) from nozzle to application point		
air pressure	uncontrolled nozzle: 3 bar (43 psi), controlled nozzle: 6 bar (87 psi)		
air requirement	approx. 200 NI/min (free air) for uncontrolled nozzle max. 40 NI/min (free air) for controlled nozzle		
operating pressure	max. 200 bar (2900 psi) for uncontrolled nozzle max. 120 bar (1740 psi) for controlled nozzle		
connections HSA-TD25, 26, 27	air:	G 1/4 female (BSPP)	
	lubricant:	G 1/4 female (BSPP)	
	fastening:	M 12	
connections HSA-TD2, 28, 29, 30	air:	8 mm tubing or hose stud	
	lubricant:	6 mm tubing or hose stud	
	fastening:	8.5 mm dia.	

Note: Air inlet is marked as „L” and lubricant inlet is marked as „S”.

Tightening torque for controlled nozzles = 20 Nm, electric monitoring signal = 20 ms.

## Dimensions

Model	Height	Length	Depth
nozzle SD	50 mm (2.0 in)	87 mm (3.4 in)	20 mm (0.8 in)
nozzle SDLMKR-EN	110 mm (4.3 in)	140 mm (5.5 in)	45 mm (1.8 in)
nozzle SDLMKR-ES	110 mm (4.3 in)	185 mm (7.3 in)	45 mm (1.8 in)
nozzle SDLMNR	110 mm (4.3 in)	140 mm (5.5 in)	45 mm (1.8 in)



# Bracket Mounting, Accessories, Mounting Plates

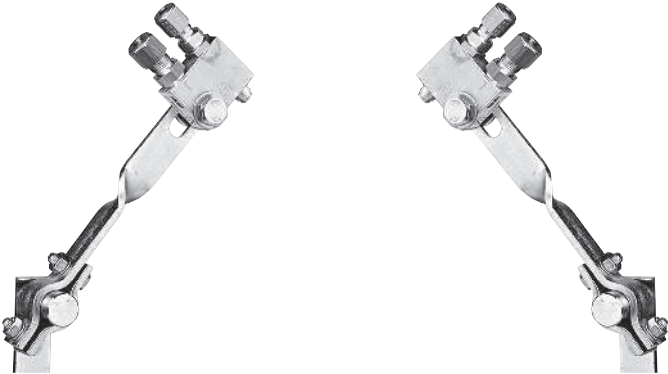

Bracket Mounting (Bracket 515-31224-1) of SD Nozzles

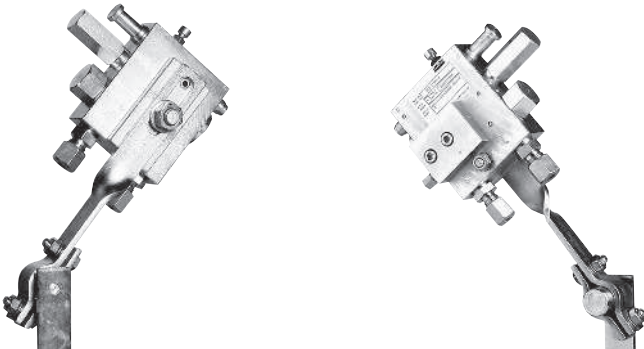

Bracket Mounting (Bracket 515-31225-1) of SDLH Nozzles

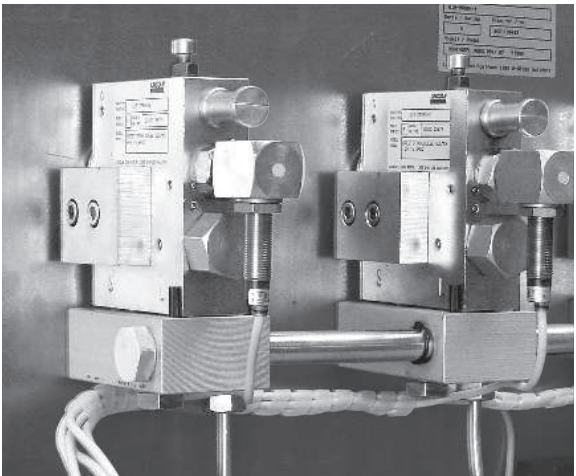

Mounting Plates with SDLM Nozzles

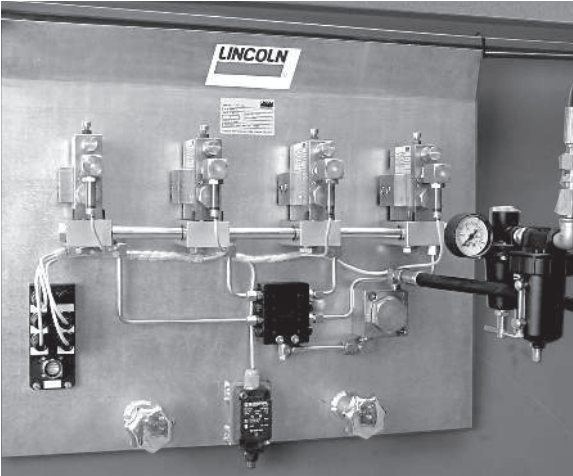

# Accessories, Lubricant Filter, Pressure Relief Unit

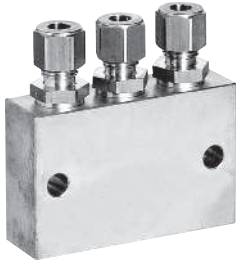

Compressed Air Block for 3 Nozzles

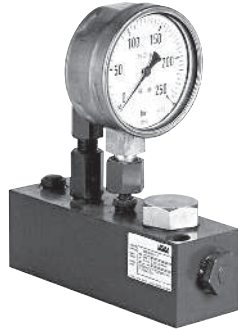

Lubricant Filter Unit



Pressure Relief Valve with Pressure Gauge

## Models

Part No.	Description	
515-31224-1	bracket for nozzles SD	
515-31225-1	bracket for nozzles SDLH...	
615-25679-1	compressed air block for 2 nozzles	air inlet: R 3/8 f (BSPT) outlets: 8 mm tube
615-25680-1	compressed air block for 3 nozzles	air inlet: R 3/8 f (BSPT) outlets: 8 mm tube
615-25681-1	compressed air block for 4 nozzles	air inlet: R 3/8 f (BSPT) outlets: 8 mm tube
628-25530-4	lubricant filter unit with pressure gauge and 120 bar (1740 psi)	
	pressure relief valve (ideal for 215 pumps used for spray systems)	
515-31252-2	pressure relief unit, 120 bar (1740 psi) with pressure gauge	
	threaded connections: G1/4 female (BSPP)	

## EOS Single-line Oil System

EOS is the reliable and most economical solution for the oil lubrication of chains. The system is a direct operating, electrically driven, single-line centralized lubrication system. The system is ideal for machines with chain drives and 12/24 VDC power supply - e.g. agricultural equipment such as balers. A typical industrial application is for packaging machine such as palletizers.

The EOS metering elements supply the required oil quantity in time-controlled intervals to brushes which evenly apply the oil to the chain.



Single-line Oil System

The required metered quantity of oil can be adjusted to properly match the working condition, the size and length of the chain. The metering range selection of 0.1, 0.3, 0.4 or 0.5 ccm provides versatility to ensure that requirements are met.

### EOS Controller

For machines without a controller, e.g. balers in the agricultural industry, Lincoln offers a 12/24 VDC controller. The run time is fixed at 4 seconds and the pause time is adjustable from 1 to 100 minutes. The controller enables a simple retrofit installment of the EOS oil lubrication system.

# EOS Single-line Oil Systems for the lubrication of Slow Moving Chains

## Model

Part No.	Description	Motor
552-32404-1	Pump EOP-12	12 VDC
552-32405-1	Pump EOP-24	24 VDC
552-32397-1	Metering element EOE, complete. 0.1 cm <sup>3</sup>	
552-32398-1	Metering element EOE, complete. 0.3 cm <sup>3</sup>	
552-32399-1	Metering element EOE, complete. 0.4 cm <sup>3</sup>	
552-32400-1	Metering element EOE, complete. 0.5 cm <sup>3</sup>	
452-70235-1	Divider bar, double	
452-70236-1	Divider bar, triple	
452-70237-1	Divider bar, quadruple	
307-19543-1	Bracket for Divider bars	
112-35255-4	Tube, PA12 HL 8.0 x 1.0, black	
112-35255-3	Tube, PA12 HL 4.0 x 0.65, black	

## Technical Data

Reservoir Size	5 l	
Dimensions (L x W x H)	180 x 205 x 302 mm	
Power supply	12 or 24 VDC	
Max. current	at 12 VDC = 5 A / at 24 VDC = 2.5 A	
Max. Operating pressure	approx 4 bar	
Theoretical output at 4 bar	0,5 l/min	
Operating temperature	0 to 40 °C	
Factory settinf*	max run time 4 sec with a pause of 30 sec.	
Suitable oils**	mineral oil SAE OW-40	
EMV	acc. To DIN VDE 879/2: 1999 03 and acc. To EN ISO 14982: 1998	
Metering elements	<b>Colour Ring</b>	<b>Output / stroke</b>
	white	0,1 cm <sup>3</sup>
	red	0,3 cm <sup>3</sup>
	green	0,4 cm <sup>3</sup>
	blue	0,5 cm <sup>3</sup>

Note: Please verify applications involving parameter variances with Lincoln GmbH before commissioning.

\* With an increase in the number of lube lines – the run time and the pause time of the electrically driven gear pump must be increased.

\*\* The following oils may not be used in the EOS: used oil, gear oil, glucose oil and plant oil.

## EOT Controller 12/24 VDC

Part No.	Description
664-34135-3	Controller 12 VDC
664-34135-4	Controller 24 VDC

See technical manual for details

## Technical Data

Power supply	12/24 VDC
Tolerance	-15/+20 %
Power rating	max. 0,65 KW
Operating temperature	-20°C...60°C

# Contact Lubrication with Guide Blocks

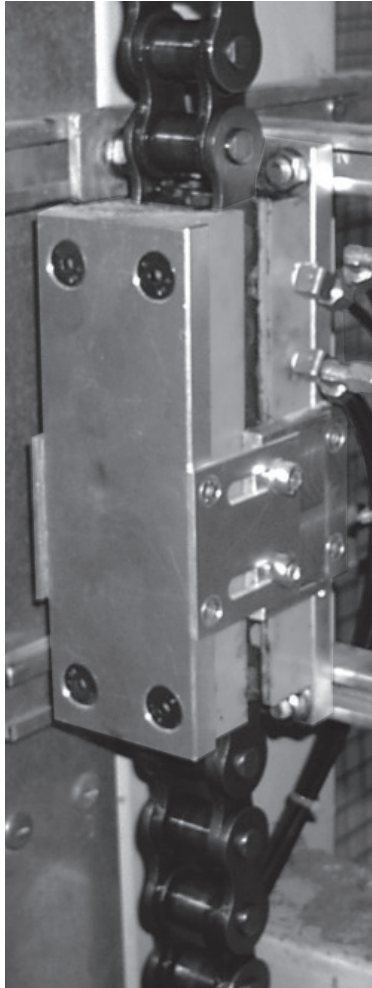

Contact Lubrication

The contact lubrication comprises 2 polymer-plastic blocks between which the chain runs. The guide blocks fit exactly to the size and type of chain (roller chains according to DIN 8187).

The upper block has channels that direct the lubricant to the chain. The lubricant is distributed along the length of the block allowing it to penetrate the chain.

This system offers essential advantages - the worst of the dirt on the chain is cleaned off, the chain is guided and supplied with continuous lubricant. The contact lubrication has an extraordinary long life thanks to highly wear-resistant plastics that are very robust and insensitive to contamination and knocks.

#### Applications

Contact lubrication is ideal for slow and fast moving chains (up to a max. of 40 m/min). All types of lubricant - from low viscosity oil to lubrication greases can be used. Lincoln centralized lubrication systems provide the optimum lubricant supply.

The system has been designed especially for chains in pallet conveyor systems, e.g. in the food and beverage industry. Pallet systems for return goods are particularly exposed to a high grade of contamination: wood chips, broken glass, and in the winter, ice particles stick to the chain and result in premature wear. Other applications for a contact lubrication system are passenger or freight elevators as well as escalators.

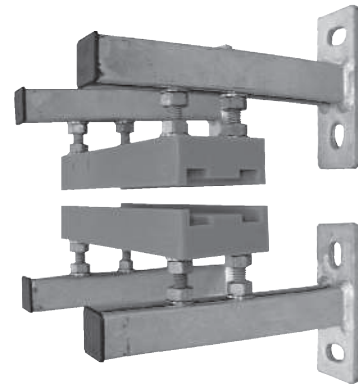

Guide Blocks & Mounting

## Selection of Available Guide Blocks for Single Roller Chains

Chain Size	DIN ISO Nr.	Type	Guide Block Description	Part No.
3/4" x 7/16"	12 B-1	upper*	compl. 200 RK-1F 3/4 x 7/16 2S	526-32700-1
		Lower**	compl. 200 RK-1F 3/4 x 7/16	526-32699-1
1" x 17 mm	16 B-1	upper*	compl. 200 RK-1F 1" x 17 mm 2S	526-32704-1
		Lower**	compl. 200 RK-1F 1" x 17 mm	526-32703-1
1 1/4" x 3/4"	20 B-1	upper*	compl. 200 RK-1F 1 1/4 x 3/4 2S	526-32708-1
		Lower**	compl. 200 RK-1F 1 1/4 x 3/4	526-32707-1
1 1/2" x 1"	24 B-1	upper*	compl. 200 RK-1F 1 1/2x 1 2S	526-32706-1
		Lower**	compl. 200 RK-1F 1 1/2x 1	526-32705-1

## Selection of Available Guide Blocks for Double Roller Chains

Chain Size	DIN ISO Nr.	Type	Guide Block Description	Part No.
3/4" x 7/16"	12 B-2	upper*	compl. 200 RK-2F 3/4 x 7/16 3S	526-32710-1
		Lower**	compl. 200 RK-2F 3/4 x 7/16	526-32709-1
2 1/2" x 1 1/2"	40 B-2	upper*	compl. 200 RK-2F 2 1/2 x 1 1/2 3S	526-32714-1
		Lower**	compl. 200 RK-2F 2 1/2 x 1 1/2 3S	526-32713-1

\* with lubricant connections M 6x1 (2S = 2 lubricant connections, 3S = 3 lubricant connections)

\*\* without lubricant connections



# Quickclub Progressive System for Grease or Oil for Slow Moving, Small Chains

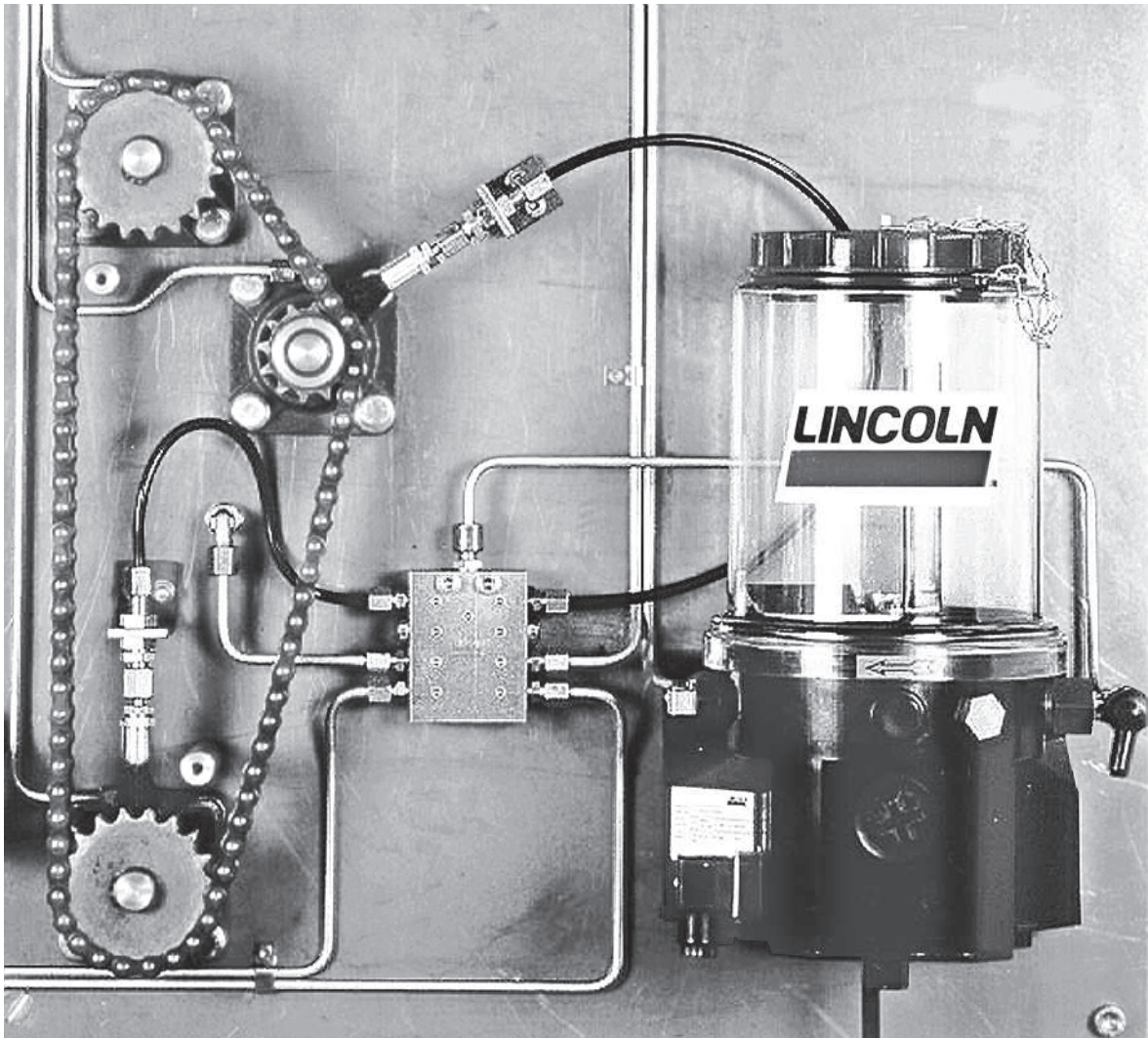

*Chain Lubrication*

**The Lincoln brush lubrication in conjunction with the Quickclub 203 pump provides an economical entry-level chain lubrication system. The Quickclub range does however offer numerous add-on possibilities. As a result, it fulfils all expectations for an easy, maintenance-friendly and high quality lubrication system.**

Brush lubrication not only lubricates the contact points of the links, but rather the entire chain. The pump supplies the lubricant either directly or via a progressive metering device to the brushes, which evenly apply the lubricant to the chain. As a result, high-viscous chain oils and lubricants up to NLGI class 2 can be easily, economically and reliably applied.

A progressive system can serve up to 100 lubrication points, thus several brushes may be positioned along the chains to ensure sufficient lubricant supply.

Optional system monitoring is offered with a 203 pump incorporating the appropriate PCB and corresponding progressive metering devices. Additional options include low level monitoring.



# Centro-Matic Centralized Lubrication System

## Oil Lubrication for slow moving chains

- The chain speed can be up to 6 m/min if brushes are used.
- For contact-free squirt applications, the chain speed is dependent on the chain division and the total number of SL-43 lubricant injectors.

The Centro-Matic system is a single-line system. One application for a Centro-Matic system is the oil lubrication of chains.

The Centro-Matic oil system operates intermittently with a change in pressure and pressure relief.

A centralized pump supplies the connected injectors with oil. The injector supplies the metered quantity of oil under pressure (52-69 bar) and the metering chamber is filled. After the main-line pressure has been relieved, the preset quantity of oil from the metering piston is forced in front of the supply piston. The Lincoln "SL" injectors are the key component of a Centro-Matic system.

The injectors are infinitely adjustable and they are equipped with an indicator pin for visual monitoring. SL-43 injectors, with a pneumatically driven single-stroke centralized lubrication pump, are most commonly used for oil lubrication of chains.

## System Advantages

- Switching on and off of individual chain groups is possible
- Exact metering, independent of oil viscosity and flow resistance
- The high operating pressure of the injector enables accurate oil expulsion
- Lubricates without compressed air

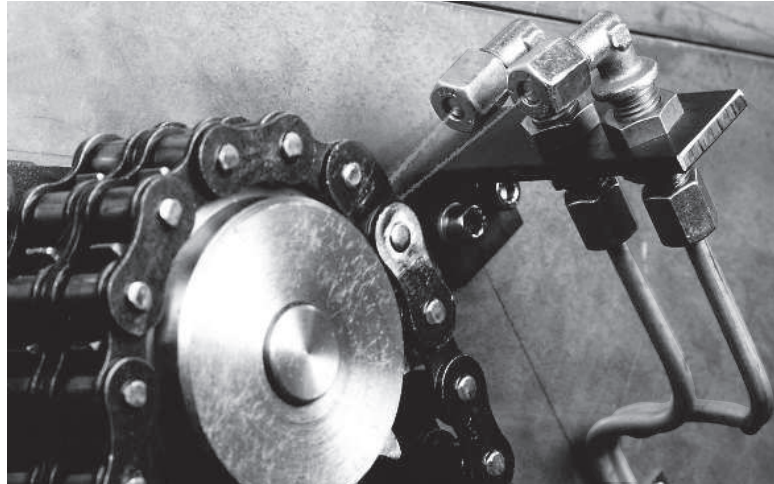

### 83667 Single-stroke Pump

Pneumatic drive  
Air inlet pressure 2.9 - 3.4 bar  
Ratio 20:1  
Output 7.3 cm<sup>3</sup>  
Reservoir capacity 2 L  
Height 470 mm

### 82885 Single-stroke Pump

(not shown)  
As above, except  
Reservoir capacity 0.59 L

Height 264 mm

*Note: Controller and pressure reducer required*

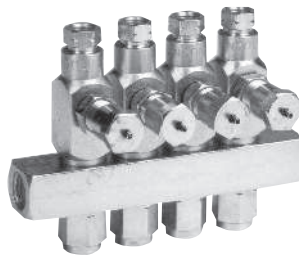

### SL-43 Injectors

Adjustable 0.016 to 0.131 cm<sup>3</sup>  
Manifolds available with 1 to 4 lubricant injectors

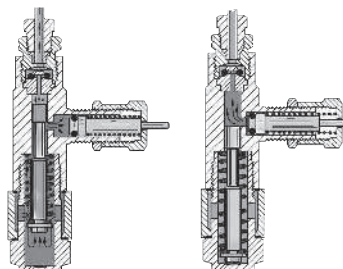

**We design each Centro-Matic chain lubrication system from individual components to suit your requirements.**

# PMA 2 Solenoid Pump with Squirt Nozzles



*PMA 2 Pump System*

**The PMA 2 solenoid pump is designed for a contact-free oil lubrication of chains. The exact metered quantity of oil is squirted without air (airless), and without producing an oil mist, while the chain is in operation. The lubricant can also be directly applied via brushes or lubrication points.**

The pump's fast cycle frequency of 5 Hertz enables trouble-free lubrication of fast moving chains. A single pump can supply 1 to 6 oil squirt nozzles.

Double-nozzles are also available which further increase the number of points served by the

pump. The metered quantity of oil per cycle is either 30 mm or 60 mm

The drive magnet is characterized by its high performance and long duty-cycle, thus enabling a reliable operation of the pump in extreme conditions.

The pump is available in 24 VDC, 120 VAC and 230 VAC versions. An optional proximity switch for the pump offers a simple method to electrically monitor the function.

Other accessories include a 13 or a 36 litre reservoir for oil. Both reservoirs are equipped with

electrical low-level control and a large filling port comprising a strainer.

## **System Advantages & Features**

- Metered oil quantity 30 mm or 60 mm per cycle
- Available in 24 VDC, 120 VAC and 230 VAC versions
- Optional electrical monitoring via a proximity switch
- 1 to 6 outlets that can serve individual or double nozzles
- Up to 5 lubrication cycles per second (depending on the system)
- Airless lubrication – oil mist free

# PMA 2 Solenoid Pump with Squirt Nozzles

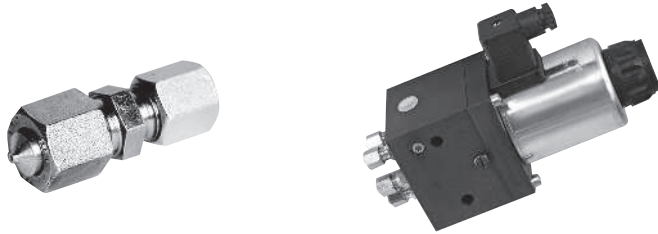

Squirt Nozzle

PMA 2 Pump

## Models with 60 mm<sup>3</sup> Output (0.0036 in<sup>3</sup>) - Standard Versions

Part No.	Description	Number of Outlets	Supply Voltage	Proximity Switch
651-40947-1	PMA 2-...-1-60-230AC	1	230 VAC	no
651-40947-3	PMA 2-...-2-60-230AC	2		no
651-40947-9	PMA 2-...-4-60-230AC	4		no
651-40948-2	PMA 2-...-6-60-230AC	6		no
651-40947-4	PMA 2-...-2-60-230AC-N	2		yes
651-40948-1	PMA 2-...-4-60-230AC-N	4		yes
651-40945-2	PMA 2-...-1-60-24DC	1	24 VDC	no
651-40945-3	PMA 2-...-2-60-24DC	2		no
651-40945-4	PMA 2-...-4-60-24DC	4		no
651-40945-6	PMA 2-...-6-60-24DC	6		no
651-40945-8	PMA 2-...-2-60-24DC-N	2		yes
651-40945-5	PMA 2-...-4-60-24DC-N	4		yes
651-40946-1	PMA 2-...-2-60-120AC	2	120 VAC	no

## Models with 30 mm<sup>3</sup> Output (0.0018 in<sup>3</sup>) - Standard Versions

Part No.	Description	Number of Outlets	Supply Voltage	Proximity Switch
651-40947-3	PMA 2-...-2-30-230AC	2	230 VAC	no
651-40947-7	PMA 2-...-4-30-230AC	4	230 VAC	no
651-40947-2	PMA 2-...-2-30-230AC-N	2	230 VAC	yes
651-40945-1	PMA 2-...-1-30-24DC	1	24 VDC	no

## Accessories

Part No.	Description
615-28660-3	Squirt nozzle for 6 mm tube
615-29209-1	Double-nozzle, straight for 6 mm tube
615-29301-1	Double-nozzle, 90° for 6 mm tube
651-28691-1	13 l plastic reservoir with electric low-level (float switch)
651-28685-1	36 l plastic reservoir with electric low-level (float switch)

# ORSCO Minimum Quantity Oil Spray System

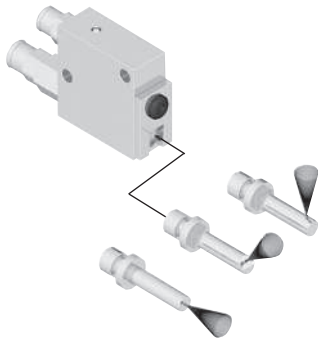

*Oil Spray System for Production Lines*

## Oil Spray System for Extreme Fast Moving Chains

ORSCO spray systems cover the entire oil lubrication range from slow to fast moving chains. It is, however, especially ideal for the lubrication of extreme fast moving chains or for critical applications where over-lubrication or product contamination must be avoided.

## Oil Spray Systems for Production Lines

A further application for the ORSCO system is for the oiling of components such as cylinders, shafts etc. in the production, as well as tool lubrication in the metal-forming industry.

Oil and spray-air are only first combined in a special mixing chamber within the nozzle. The compressed air acts merely as a transport medium to carry the minute oil quantity to the point of lubrication (not an oil-mist lubrication).

Each nozzle is supplied intermittently (minimum cycle frequency of 2 Hz) by a pneumatically operated injector pump with a metered amount of oil (15 mm or 60 mm).

Depending on the injector version and the cycle frequency, either an ultra-fine or a thicker oil film is applied.

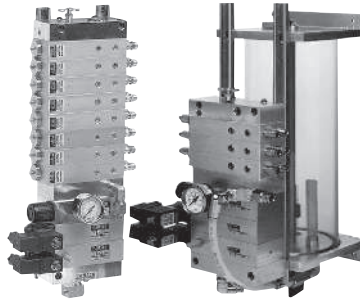

*Pump Series VS, Without Reservoir  
Pump Series VSR, 4L Oil Reservoir*

## Orsco Spray Nozzles

Numerous nozzle types, in various versions, enable the ORSCO spray system to cover most applications.

The spray nozzles type „SWN“ (as shown) with different spray patterns are used for example in chain lubrication applications. Spray nozzle SWN LP has the connections on the side, while SWN IL has the connections at the back. Please inquire for further detailed information.

## Compact Series Pumps

When an existing PLC is available, our standard components can be easily used.

The standard series can accommodate up to 8 injector pumps - with either 15 mm or 60 mm per stroke. The modules are available with or without components such as air solenoids, pressure switches, air filter/regulator, etc.

Where required, we configure & design each pump assembly to exactly match your needs and specific application.

## Lubrication System Series

These modules are complete pre-assembled lubrication system stations that include a controller, air solenoid valves, air filter, oil reservoir and injector pumps.

The number and type of injector pumps are selectable. The standard Series 170 system (see photo) is available with up to 16 injector pumps with a choice of 15 mm or 60 mm output per stroke.

The list of equipment for each module can be individually configured from standard components. Please ask us for further details.

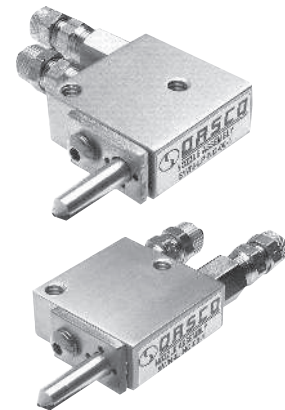

*Spray Nozzle - SWN LP, Side Connections  
Spray Nozzle - SWN IP, Back Connections*

Please inquire about custom tailored lubrication systems (Series 200 & 300) with more than 16 injector pumps, and/or customer specific controllers, or with additional monitoring functions. We will design a system to your specifications.



*Standard System Series 170 Typ 170*



# Cobra Lubricator

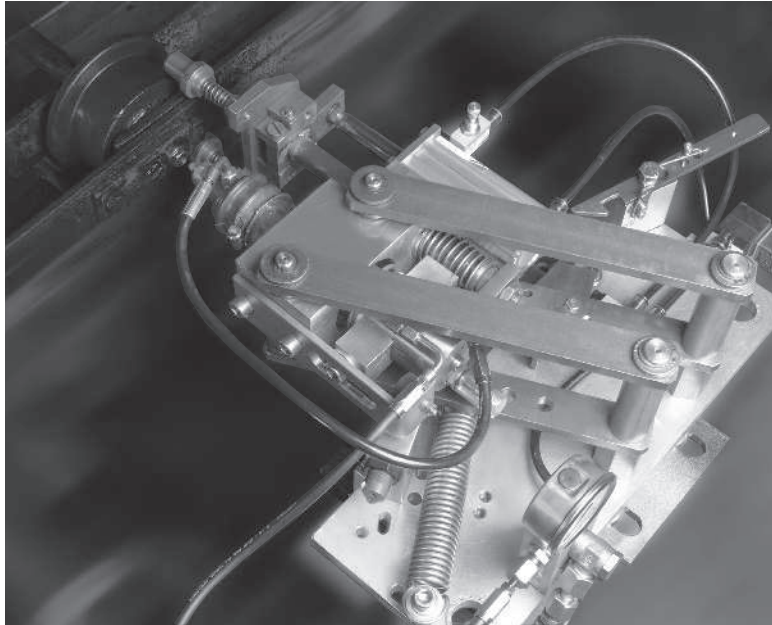

Cobra 1X

The enhanced Cobra 1X from Lincoln's chain lubrication range is particularly suitable for conveyor chains and conveyor lines, in which the inner roller and stud of the chain are lubricated while the chain is in operation. The system can supply either NLGI class 2 grease or oil.

A new drive technology, which is a combination of a pneumatic and mechanical drive, as well as a newly designed lubrication head, provides two key advantages:

- The load subjected to the chain is substantially lower

- A higher maximum lubricant pressure of up to 150 bar

The newly designed lubrication head enables an exact metering from 0.2 cm to 2 cm per lubrication cycle, and the adjusting screw permits infinite metering adjusting within this range. Visual monitoring is performed via an indicator pin.

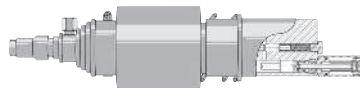

Metering and Monitoring Unit

## System Benefits

- For oil and grease up to NLGI class 2
- Lubrication frequency of 1 cycle per second.
- Supply quantity of 0.2 cm to 2 cm per stroke
- Lubricant pressure of max. 150 bar
- For chain speeds up to 24 m/min
- Manual Start/Stop or optional automated (electro pneumatic)
- Visual monitoring via indicator pin
- No control cabinet required (for the standard version)

## Applications

- Mining
- Steel & iron industry
- Cement industry
- Automotive plants
- Food processing operations

For complicated applications with intricate access – we offer a complete pneumatically controlled Cobra 501 unit.

Cobra systems can be individually designed to suit your application. Our project & systems engineers will gladly offer you a custom-designed system to match your requirements

## Technical Data

Max. lubrication cycle frequency	1 lube impluse every second
Max. chain speed	400 mm/s (24m/min)

### The following information is necessary when requesting a quote for a Cobra system

- Number of chains
- Distance between the chains
- Deviations of lubricating nipple – horizontally and vertically
- Position of chain at Cobra mounting place
- Number of lubricating points/chain
- Does the chain move forward and backward?
- Speed of chain
- Pitch of chain
- Total length of chain/conveyor
- Type of operation – continuous, interval (pause and run times needed)
- Type of lubricating nipple
- Temperature in mounting area
- Compressed air supply pressure
- Electrical supply
- Environmental influences – humidity, aggressive environment, etc.
- Type of lubricant



# CRL 101 – Automated Wheel Flange

## Lubrication for rails and wheels of cranes and other Rail Vehicles

The Lincoln CRL 101 uses two lubrication rollers for the left and right flank of the crane rail to evenly apply lubricant.

Regular lubrication of rails considerably increases the life expectancy of the wheels and reduces the wear on the rail itself. This lowers repair costs and more importantly, reduces costly down-time.

**The system is suitable for all types of cranes that operate on a rail profile according to DIN 536 Part 1 (size A 45 to A 120). It is especially ideal for harbour cranes, as well as overhead or gantry cranes.**

The lubricant supply to the lubricant rollers is typically provided by a Lincoln multiline pump type 205 and a downstream progressive metering device type SSV6-K. The indicator pin on the metering device can be used to visually determine if lubricant is evenly flowing.

The pump is available in different ratios and with an adjustable pump element, thus enabling the exact matching of output versus requirement. As a result, in most cases an electrical control panel for the pump is not required. The drive of the pump is simply run in tandem with that of the crane's drive.



Wheel Flange Lubrication

The pump reservoir is available in 4, 8 or 30 liter capacity (with optional low level control). Biodegradable lubricants or lubricant with added solid particles may be used. Please contact us for queries on approved lubricants.

### System Characteristics

- Reservoir capacity: 4l, 8l or 30l – optional electric level control
- For crane rail widths from 45 to 120mm
- R 1/4" flexible lubrication line connection

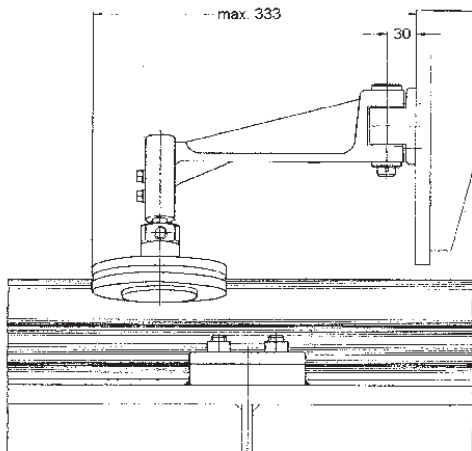

Schematic: Wheel Flange Lubrication

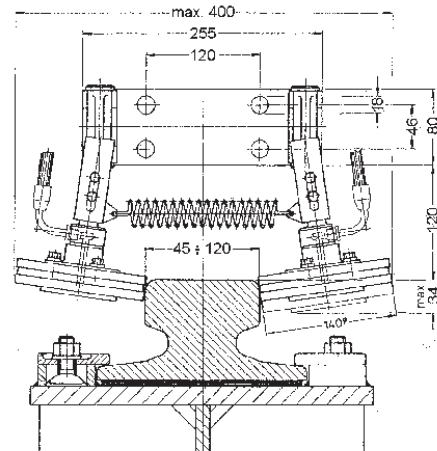

# Hydrostatic Bearing Lubrication (Oil)

## Applications

- Hydrostatic and hydrodynamic lubrication of large bearings (Cement kilns)
- Turbines
- Steel mills
- Gears
- Paper machines
- Power stations

The systems may be classified into the following groups:

- Oil supply systems - hydraulic
- Lubrication oil supply systems
- Blocking oil systems (used to maintain separation points - e.g. different pressures or mediums)
- Regulation / control oil systems

The systems differ largely depending on the requirements and desired features of the customer. Our project engineers are always pleased to provide you with a tailor-made system to meet your application.

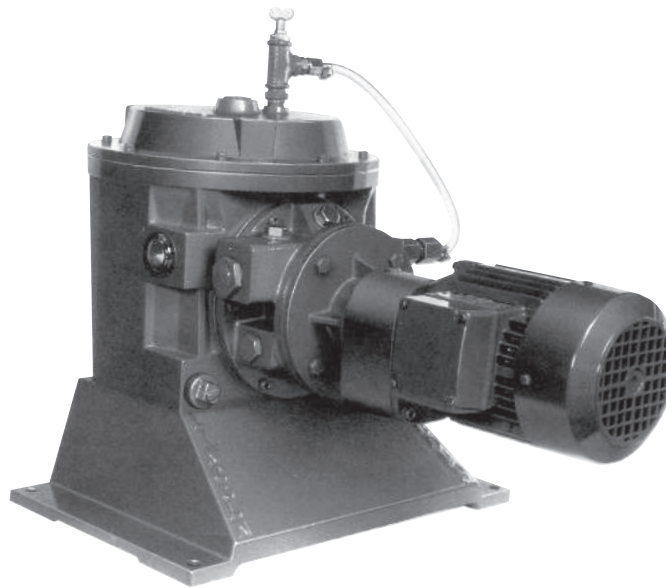

ZPU09

## ZPU09/09A Pump for Hydrostatic Lubrication

This high pressure central lubrication pump is designed for use in hydrostatic lubrication systems only. It is available with one or

two outlets and is suitable for the supply of oils with a viscosity of 20 to 460cSt.

## Models

Part No.	Description	Number of Outlets	Motor
605-27545-1	ZPU09/08GT-380-415,420-480	1	3-phase gear motor, multi-range 380-415/420-480 V
605-27546-1	ZPU09/08GT-500	1	3-phase gear motor, 500 V
605-27547-1	ZPU09A/08GT-380-415,420-480	2	3-phase gear motor,
605-27548-1	ZPU09A/08GT-500	2	3-phase gear motor, 500 V
605-28960-1	ZPU09/08ST-380-415,420-480	1	3-phase gear motor, multi-range 380-415/420-480 V
605-28166-1	ZPU09/08GT-000	1	without motor

## Technical Data

	ZPU09	ZPU09 A
Number of outlets	1	2
Lubricant output	8 liters/hr. (2.1 U.S. gal/hr.)	2 x 4 liters/hr. (2 x 1 U.S. gal/hr.)
Max. operating pressure	400 bar (5800 psi)	
Drive speed	60 rpm	
Reservoir capacity	8 l	
Connection Threads	Pressure line G 3/8 female (BSPP) Filling line G 3/8 female (BSPP)	

# Supply Systems



*Bulk Supply System*

## **Application**

- Bulk supply systems
- Complete plant systems

We offer complete plant lubrication supply systems that, from a single source, supply an entire network of systems.

Container pumps or, if needed, booster pumps are used to supply secondary pump stations.

Booster pumps are used to assist in pumping lubricants over extremely long distances. When tube lengths exceed several hundred meters, booster pumps are required to boost the pressure.

Lincoln's lubrication supply systems guarantee trouble-free operation in all sorts of applications.



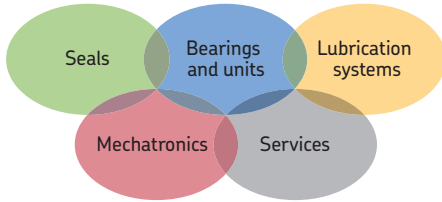

### The Power of Knowledge Engineering

Drawing on five areas of competence and application-specific expertise amassed over more than 100 years, SKF brings innovative solutions to OEMs and production facilities in every major industry worldwide. These five competence areas include bearings and units, seals, lubrication systems, mechatronics (combining mechanics and electronics into intelligent systems), and a wide range of services, from 3-D computer modelling to advanced condition monitoring and reliability and asset management systems. A global presence provides SKF customers uniform quality standards and worldwide product availability.

#### **!** Important information on product usage

All products from Lincoln may be used only for their intended purpose as described in this brochure and in any instructions. If operating instructions are supplied with the products, they must be read and followed.

Not all lubricants are suitable for use in centralized lubrication systems. Lincoln does offer an inspection service to test customer supplied lubricant to determine if it can be used in a centralized system. Lincoln lubrication systems or their components are not approved for use with gases, liquefied gases, pressurized gases in solution and fluids with a vapor pressure exceeding normal atmospheric pressure (1 013 mbar) by more than 0,5 bar at their maximum permissible temperature.

Hazardous materials of any kind, especially the materials classified as hazardous by European Community Directive EC 67/548/EEC, Article 2, Par. 2, may not be used to fill SKF centralized lubrication systems and components and delivered and/or distributed with the same.

## SKF Lubrication Systems Germany GmbH

Heinrich-Hertz-Str. 2-8 · 69190 Walldorf

Germany

Tel +49 6227 33-0

Fax +49 6227 33-259

© SKF is a registered trademark of the SKF Group.

© Lincoln, BearingSaver, Centro-Matic, Duo-Matic, Helios, ModularLube, ORSCO, PileDriver, PowerMaster, PowerLuber and Quicklub are registered trademarks of the Lincoln Industrial Corp.

© SKF Group 2015

The contents of this publication are the copyright of the publisher and may not be reproduced (even extracts) unless prior written permission is granted. Every care has been taken to ensure the accuracy of the information contained in this publication but no liability can be accepted for any loss or damage whether direct, indirect or consequential arising out of the use of the information contained herein.

October 2015 · FORM W-114-EN-1510





**LINCOLN**

[lincolnindustrial.de](http://lincolnindustrial.de)

[skf.com/lubrication](http://skf.com/lubrication)