

SKF Multilog On-line System IMx-M

State of the art solution for protecting and enhancing the reliability of your critical machinery



The SKF Multilog On-line System IMx-M is the latest addition to the current generation of powerful, cost effective solutions suitable for a variety of machinery monitoring applications. Together with SKF @ptitude Observer software, the SKF Multilog IMx-M can provide a complete system for initiation of machinery shutdown, early fault detection, and diagnosis. In addition, the SKF Multilog IMx-M system can provide automated advice for correcting existing or impending conditions which can affect machine reliability, availability and performance.

Key features

Machine protection

- 19-inch rack format
- Design based on API 670 requirements
- Up to 64 analogue inputs (dynamic and static) per rack
- Up to 32 digital / speed inputs per rack
- Up to 96 relay outputs per rack
- Multiple transducer types
- Radial vibration, position, temperature
- TSI measurements (absolute shaft vibration, eccentricity, and complementary differential expansion)

- Simultaneous measurement of all input channels
- Redundant Modbus RTU communications
- Buffered outputs front and rear
- Local status indication and display
- Flexible voting logic
- Customisable filters

Machine condition monitoring

- Independent of machine protection
- DC to 40 kHz frequency range
- Overall level and vector processing
- Spectrum with up to 6 400-line resolution
- Transient and steady-state data capture
- Multi-parameter gating
- SKF Acceleration Enveloping – an SKF technique used to detect impact based defects
- Adaptive alarm levels
- Data buffering in non-volatile memory
- Supported in specific versions of SKF @ptitude Observer
- Pre and Post event data capture
- Exception based data storage; Independent Normal and Alarm storage rates, store data when the parameter value changes by more than a pre-defined amount



SKF Multilog IMx-M system overview – front view

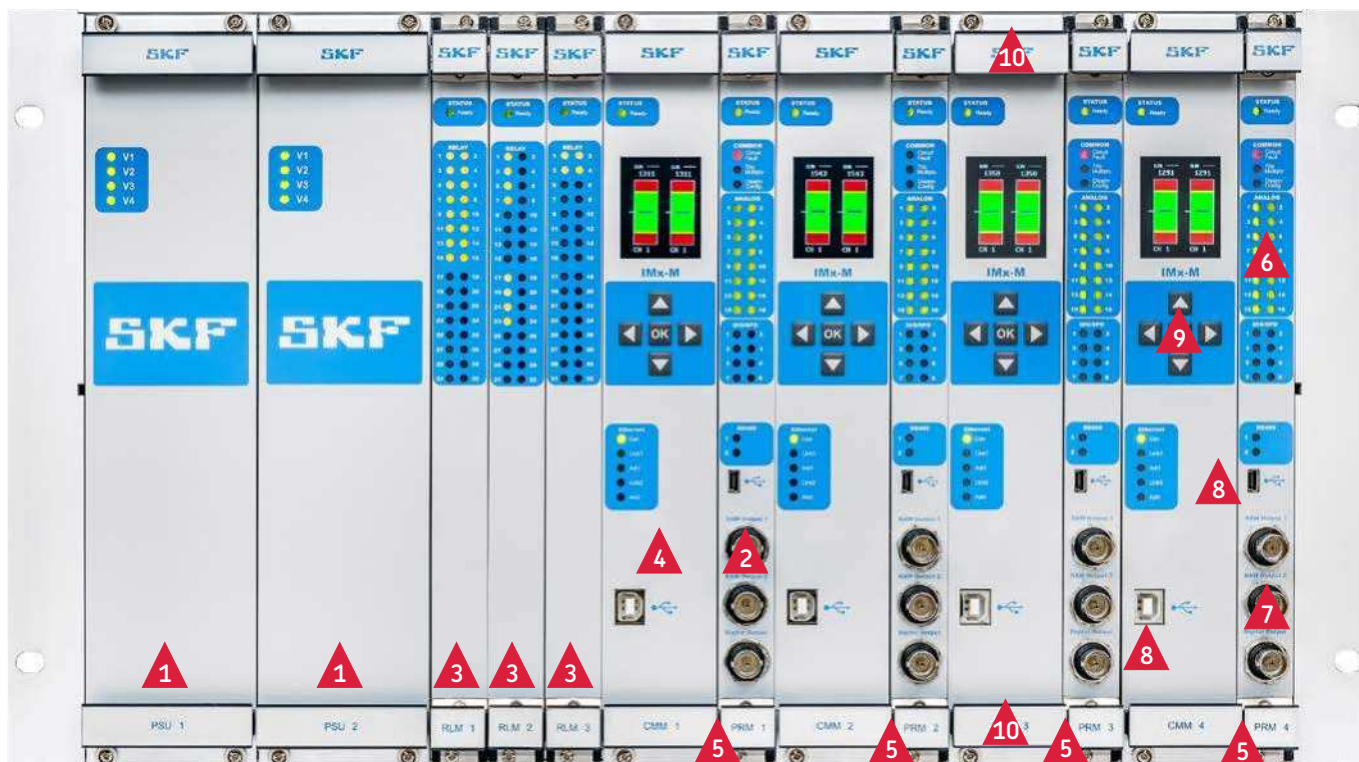

1 Power supplies, 90 to 240 VAC

Single or dual redundant. Each power supply alone may power a fully loaded rack.

2 Machine Protection module

Supports multiple transducer types and performs signal processing for alarm generation, across 16 dynamic channels and eight digital inputs. Segregation of input channel processing such that any single circuit failure cannot affect more than two channels.

3 Relay module

32 electro-mechanical relays with configurable logic assigned to any channel in the 19-inch rack, LEDs indicators and relay status.

4 Condition Monitoring module

Parallel data-acquisition of dynamic data for machinery analysis and diagnostics independent of protection function. Also provides user interface and TCP/IP communications.

5 16 channel Condition Monitoring module and Machine Protection module pair

Consisting of 16 channel Machine Protection module and 16 channel Condition Monitoring module. Up to four pairs per 19-inch rack. Configuration shown is maximum – 64 channels with 96 relays.

6 LED Indication

Multiple LED indications including individual channel plus Module OK status. Each analogue channel LED is multi-colour and indicates Alert, Danger and Transducer OK status.

7 Front buffered outputs

Three BNC connectors on the front of the Machine Protection module provide direct access to buffered transducer signals. Channel assignment using keypad on Condition Monitoring module. Ideal for use with portable data analyzers (two channels + phase).

8 USB ports

For direct configuration of Condition Monitoring module and Machine Protection module pair.

9 Local user interface

Condition Monitoring module provides channel value and alarm status bargraph display for any two channels, selectable by the keypad. Communications and System OK indication LEDs.

10 Custom label holder

All handles top and bottom, can be used for optional custom labelling. Simply slide out the plastic cover to insert your own customised label(s). This drastically simplifies the installation of identification labelling, to a system in the field.

SKF Multilog IMx-M system overview – rear view

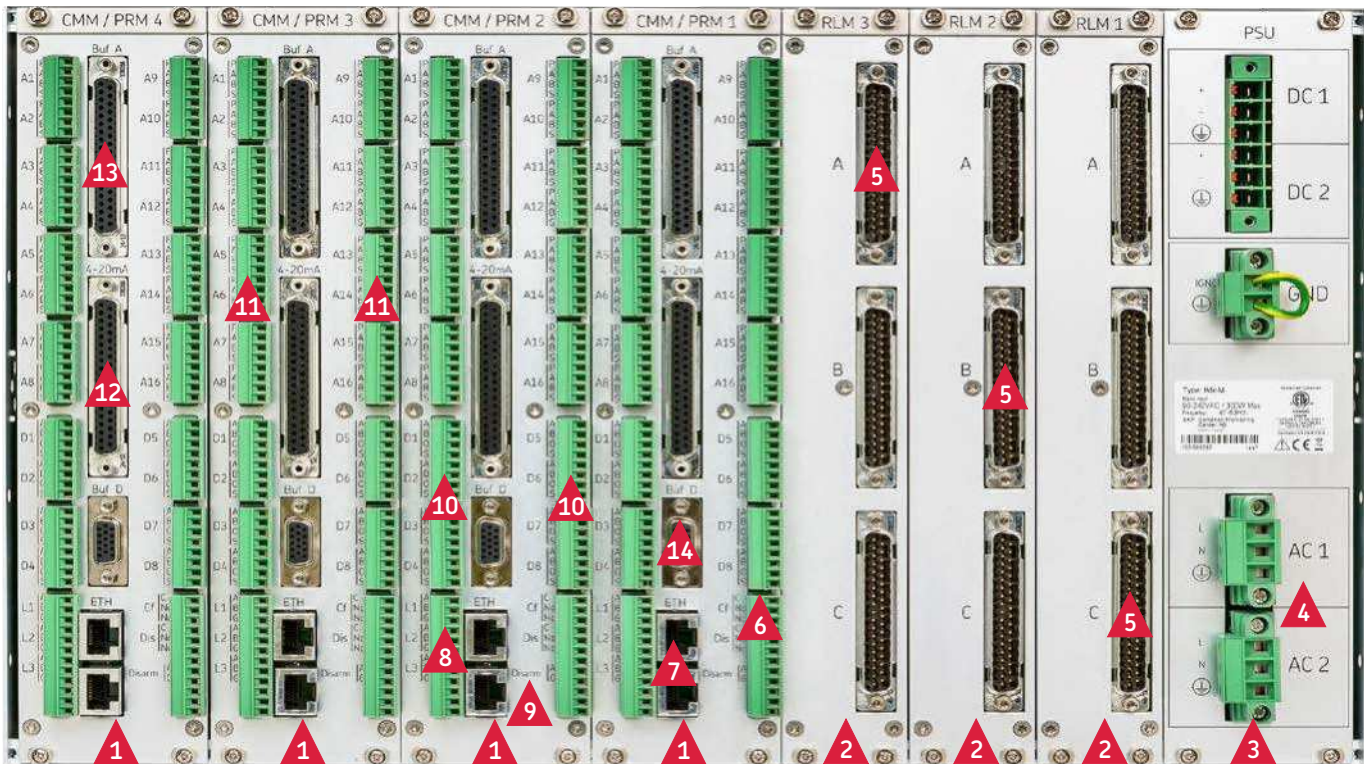

1 Condition Monitoring module and Machine Protection module pairs, input and output connectors
Maximum four pairs per rack

2 Relay module connectors
Maximum three modules per rack

3 Power supply and ground connections
Maximum two power supply modules per rack

4 Redundant AC power feeds

5 Relay outputs
For machine protection

6 Status relays
For circuit fault and disarm indication

7 Ethernet connections to Condition Monitoring (CMM) module with internal switch
For convenient interconnection of CMM modules with external network. Each CMM module has an individual TCP/IP address.

8 Redundant RS 485 communications
Two separate RS 485 lines (L1, L2) provide redundant connections to DCS. No single protection module failure or removal will affect DCS communications with other modules.

9 Disarm
Activation by contact closure

10 Digital field inputs
Sensor types include, but not limited to:

- Eddy current probes (phase reference and speed)
- TTL inputs for speed
- Logical inputs

11 Analogue field inputs
Sensor types include, but not limited to:

- Eddy current probes (radial vibration, position)
- Accelerometers and velocity sensors
- Temperature RTD (Pt 100)
- Process variables (4 to 20 mA)
- DC voltage

12 4 to 20 mA outputs
16 recorder outputs, assignable to monitored channel variables (one output per channel)

13 Rear analogue buffered outputs
For connection to external multi-channel data analyzers

14 Digital buffered outputs
Re-transmission of tachometer signal to other systems

System modules, components and technical data

- CMON 2007 19-inch rack with backplane and power supply connections (→ **page 4**)
- CMON 2102 Machine Protection module (→ **page 6**)
- CMON 2103 Condition Monitoring module (→ **pages 6 and 8**)
- CMON 2118 Machine Protection and Condition Monitoring module pair, input / output connector board (→ **page 8**)
- CMON 2109 Relay module (→ **page 10**)
- CMON 2119 Relay module, connector board (→ **page 10**)
- CMON 2202 Power Supply module (→ **page 11**)

Certifications

- CE conformity according to EN 61000-6-4:2007, EN 61000-6-2:2005, EN/IEC 61010-1:2010, EN/IEC 61010-1:2001
- ETL certified according to UL 61010-1 2nd Edition, CAN/CSA-22.2 no. 61010-1 2nd Edition
- IEC 61010-1: 2010
- IEC 61010-1: 2001
- CAN/CSA 22.2, no. 61010-1, 2nd Edition
- UL 61010-1, 2nd Edition
- AS 61010-1: 2003

Specific design requirements

- Designed to comply with API 670

CMON 2007

19-inch rack with backplane (including power supply connectors)

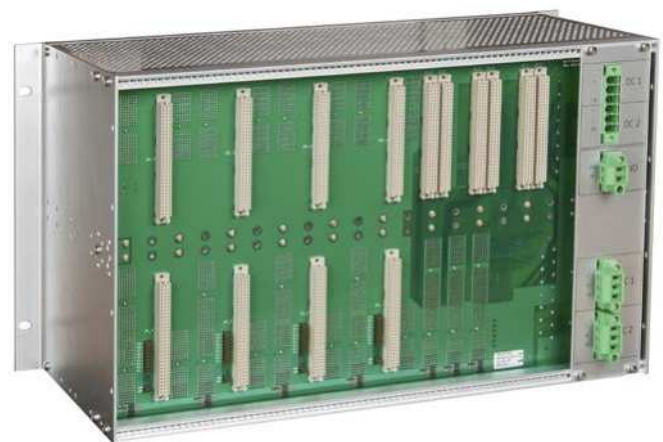
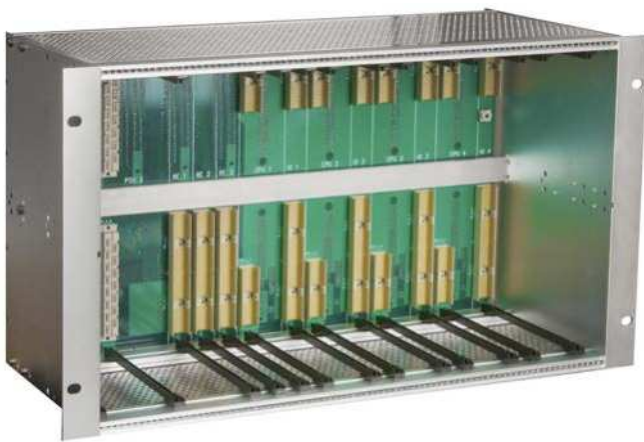

Key features

- Standard 19-inch rack mounted
- Standard 6U height
- Robust aluminium design

The 19-inch rack enclosure contains the electronics of the SKF Multilog IMx-M.

Each rack holds up to four Machine Protection and Condition Monitoring module pairs, three relay cards and up to two redundant power supplies. The rack has a backplane providing electrical interconnections between Condition Monitoring and Machine Protection module pairs, relay cards and power supplies. All module pairs are 100% isolated from one another so that failure of

one module pair, cannot influence another module pair. All modules are inserted from the front side of the rack. On the rack rear, there are termination boards for each module set.

Technical data

Backplane

- Two slots for power supplies
- Four, two slot pairs (one Machine Protection and one Condition Monitoring module, always mounted in pairs)
- Three slots for relay cards
- Screw terminals, RJ45 and D-sub connectors on rear of unit

- Redundant power bus to Machine Protection and Condition Monitoring modules, total eight per rack (4 pairs)

Physical

- 19-inch rack mounted, 6U high
- Dimensions:
 - Height: 266 mm (10.47 in.)
 - Width: 482 mm (18.98 in.)
 - Depth: 240 mm (9.45 in.)
- Weight (bare rack): 3,5 kg (123 oz.)

Environmental

- Temperature range: –20 to +65 °C (–4 to +149 °F)
- Humidity: 95% relative humidity (non-condensing)

CMON 2007 Rack dimensions

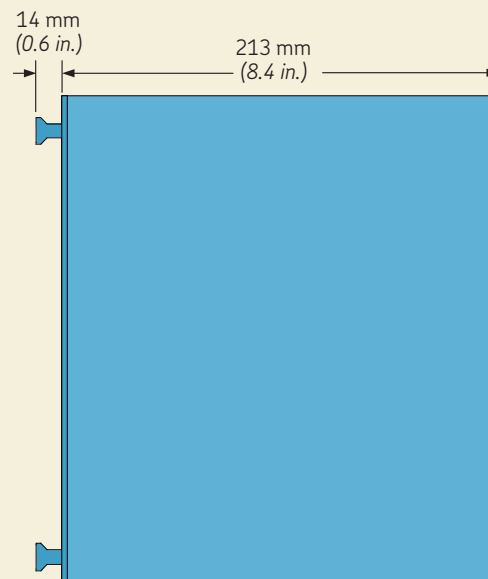
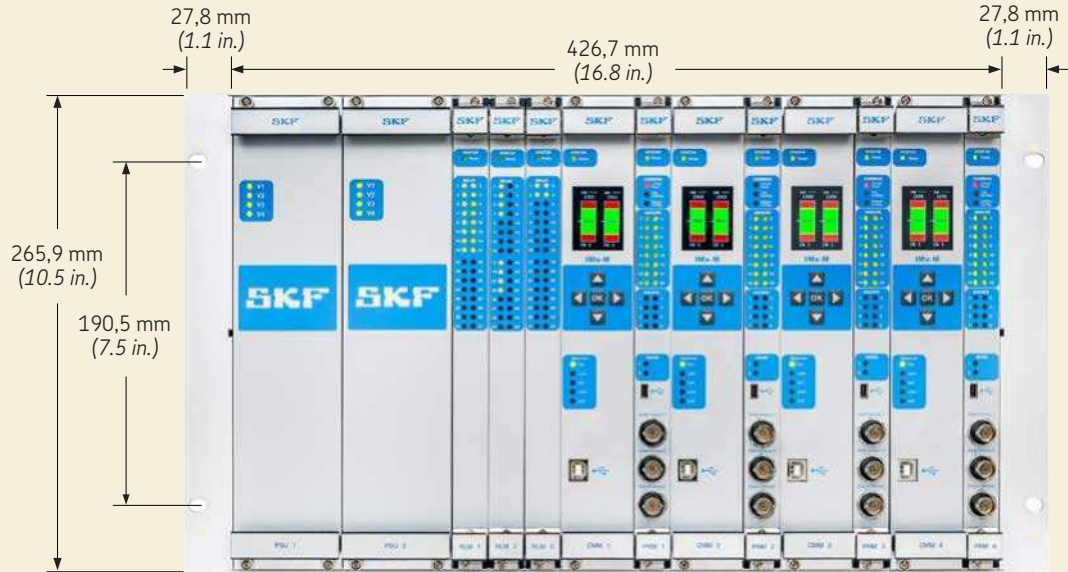

CMON 2102

Machine Protection module

Key features

- Design based on API 670 requirements
- Multiple transducer types
- RTD temperature (Pt 100)
- Radial vibration, position, temperature
- TSI functions (absolute shaft vibration, eccentricity, complementary differential expansion)
- Simultaneous measurement of all channels
- Redundant Modbus RTU communications
- Buffered outputs front and rear
- Local status Indication and display
- Flexible voting logic
- Programmable filters
- 4 to 20 mA outputs
- 90 dB dynamic range, 100 dB cross-talk rejection

The CMON 2102 Machine Protection module accepts a variety of sensor inputs. Signals such as vibration, acceleration, velocity and displacement or other parameters are easily accepted. Each input can be configured for standard accelerometers, velocity sensors, proximity probes, 4 to 20 mA or ± 23 V. All channels are processed in parallel.

In addition to the analogue channels, eight digital channels may be used for measuring speed or switch input (digital status).

The design prevents a single circuit failure from affecting more than two measurement channels. Circuit faults are indicated via LEDs, digital communications interface (Modbus protocol) and relay. All channel pairs are independent, and can be configured for redundancy. Each channel has indicators for alarm / shutdown and it is possible to manually bypass alarm and shutdown (alert / danger) functionality. The system provides remote reset of latching alarm / shutdown conditions.

Technical data

Physical

- 19-inch rack mounted
- Size: 6U high, 4TE wide
- Weight: 0,5 kg (18 oz.)

Environmental

- Temperature range: -20 to $+65$ °C (-4 to $+149$ °F)
- Humidity: 95% relative humidity (non-condensing)

Analogue inputs

- 16 analogue differential inputs (8 can be used for RTD's)
- Individual ± 24 V (23.5 to 28 V) power supply, maximum 30 mA/channel
- Power supply for standard accelerometers (8 mA constant current) for each channel
- Input range: ± 23 V
- Impedance: >100 k Ω
- Amplitude accuracy: Typically better than $\pm 1\%$ of full scale
 - Velocity input:
 - 0 to 1.0 IPS $\pm 2\%$ of full scale
 - 0 to 2.0 IPS $\pm 1\%$ of full scale
 - Specified at $+25$ °C ($+77$ °F)
 - Filters $\pm 0,5$ dB in passband
- Other inputs (V DC/mA)
 - V DC: -24 to $+24$ V
 - mA: 4 to 20

NOTE: ($\pm 2\%$ of a full scale range of 10 V)

Digital inputs

- 8 digital Opto isolated inputs with individual ± 24 V (23.5 to 28 V) power supply, maximum 30 mA/channel (TTL two-wire tachometers, three-wire tachometers, pulse, etc.).
- Eddy current probes supported on 4 digital inputs (-24 V DC supply)

Outputs

- 16 rear analogue buffered outputs, cutoff frequency (-3 dB) at 60 kHz
- 8 rear digital buffered outputs
- Two analogue buffered outputs at front (user selectable output channel)
- One digital buffered output at front (user selectable output channel)
- Single 4 to 20 mA output per analogue channel

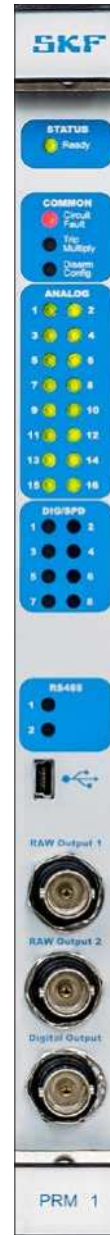

CMON 2102

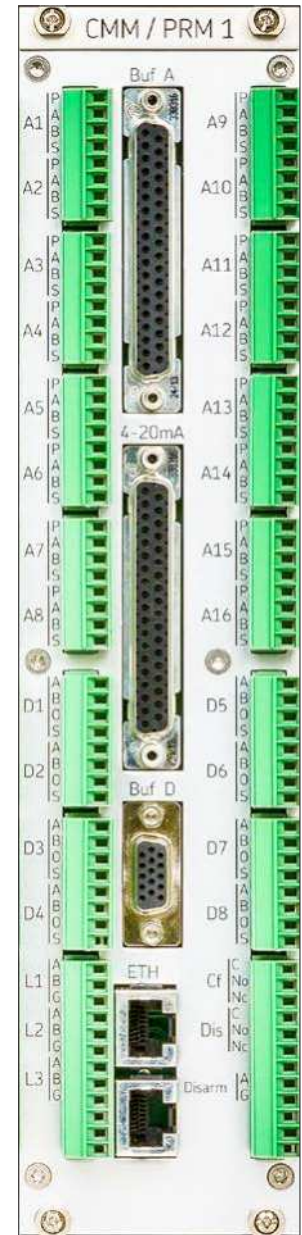

CMON 2118

- Dual digital communications link
 - Alarm status, channel value, OK limits, alarm setpoints, diagnostics, trip multiply status, channel enabled / disabled, slot enabled / disabled

Processing

- Radial shaft vibration (Overall: displacement)
- GAP / Bias
- Casing vibration (velocity, acceleration)
- Absolute shaft vibration
- Position
- RPM: 0,1 Hz to 7,5 kHz (eddy current probe minimum >2 Hz / 120 rpm, GAP dependent)
- Detection: true Peak to Peak, true Zero to Peak ("true Peak to Peak" / 2), true RMS
- Temperature (°C, °F)
- Static parameters (psi, bar, mbar, hPa, Pa, MPa, kPa, mA, A, mV, V, kV, kVA, C, F, W,

- kW, MW, %, mH, T, °, kg/cm², cmHg, um, mm, g, mm/s, mils, ips)
- TSI functions (absolute shaft vibration, eccentricity (direct) and complementary differential expansion)
- Piston rod drop (average / triggered)
- Filters:
 - Programmable selections
 - 5 to 1 000 Hz, 10 to 1 000 Hz, 1 to 600 Hz, 4 to 4 000 Hz, 10 to 5 000 Hz, 1 to 10 000 Hz, displacement, velocity and acceleration
 - 10 to 5 000 Hz and 1 000 to 10 000 Hz, acceleration and velocity, single channel on a paired channel group and no integration

- User defined filters (1 Hz steps from 1 Hz to 2 400, 4 800 Hz)
 - Roll-off rate: 24 dB/oct
- Digital / Speed processing
 - Peak Speed

Interface

- USB service interface
- RS 485, Modbus, redundant, bi-directional

Other

- Local storage of minimum 1 400 events per Machine Protection module

CMON 2102 Machine Protection module (front view)

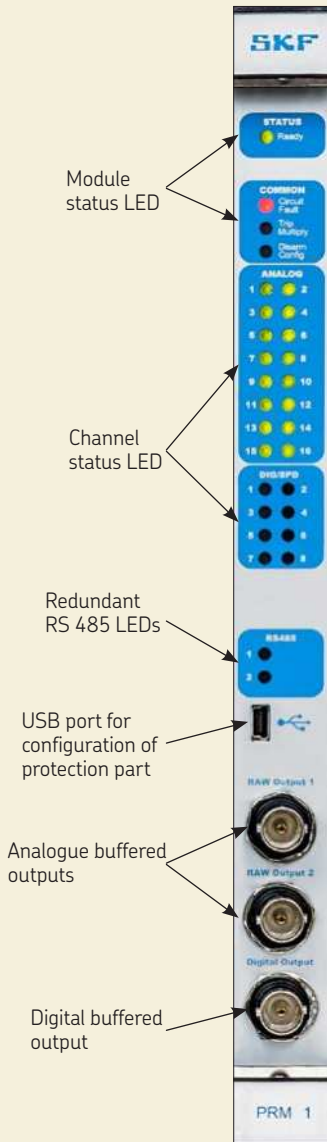

CMON 2118 Machine Protection and Condition Monitoring module pair, input / output connector board (rear view)

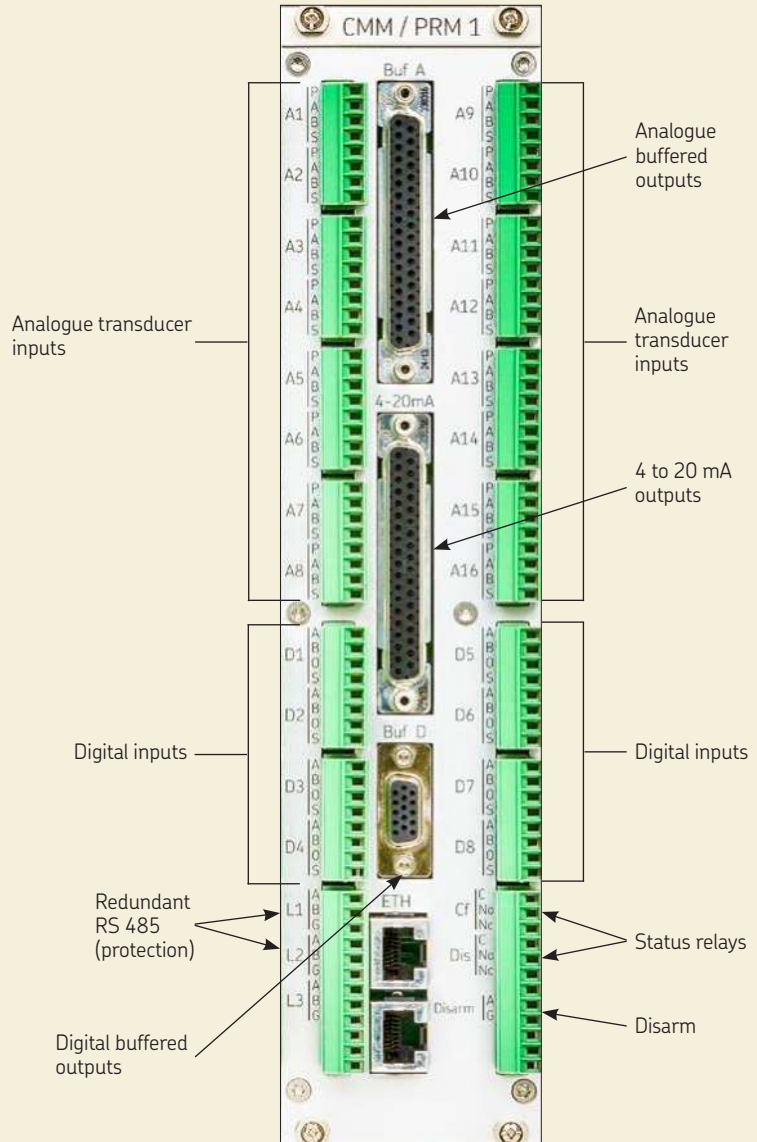

CMON 2103

Condition Monitoring module

Key features – machine condition monitoring

- Independent of machine protection
- DC to 40 kHz frequency range
- Overall level and vector processing
- FFT up to 6 400-line resolution
- Transient and steady-state data capture
- Multi-parameter gating
- SKF Acceleration Enveloping
- Adaptive alarm levels
- Data buffering in non-volatile memory
- Supported in specific versions of SKF @ptitude Observer
- Pre and Post event data capture
- Exception based data storage; independent Normal and Alarm storage rates, store data when the parameter value changes by more than a pre-defined amount
- Shaft center line
- Up to 2x static/sec and 1 dynamic/sec in transient mode
- Full Spectrum
- Up to 10 bands / measurement

The Condition Monitoring module offers data acquisition for condition monitoring purposes, and is independent of the machinery protection function. It acquires and processes data from all channels simultaneously and in parallel. This allows for multiple advanced signal analysis methods to be employed. Several measurement points can be connected to each channel signal and individual conditions for warning and alarm may be set for each point. These conditions can be based on fixed frequencies and / or speed-following frequencies (including harmonics). For each measurement point, multiple conditions can be applied – such as warning and alarm levels controlled by machine speed or load. A built-in hardware diagnostic system continuously checks all sensors, cabling and electronics for any faults, signal interruption, short circuits or power failure. Any malfunction can be set to trigger an alert alarm. In the case of system power failure, the system will automatically restart when the power returns.

Technical data

Physical

- 19-inch rack mounted
- Size: 6U high, 8TE wide
- Weight: 0,6 kg (21 oz.)

Environmental

- Temperature range: -20 to $+65$ °C (-4 to $+149$ °F)
- Humidity: 95% relative humidity (non-condensing)

Analogue measurement

- 24-bit AD conversion, no gain or AC/DC switching necessary
- True simultaneous sampling of all 16 channels (no multiplexing)
- Simultaneous sampling of different channels with different sampling rates
- Frequency range: From DC to 40 kHz
- Dynamic range: 120 dB
- Signal to noise ratio: 90 dB
- Cross-talk rejection: 100 dB
- Amplitude accuracy (typical):
 - $\pm 2\%$ (up to 10 kHz)
 - $\pm 5\%$ (10 to 20 kHz)
 - $\pm 10\%$ (up till 30 kHz)
- Phase accuracy: $\pm 3^\circ$ (up to 100 Hz)
- SKF Acceleration Enveloping (1 to 4), custom band demodulation and DPE demodulation (4 bands)
- Advanced gear analyses

Digital measurement

- Frequency range: 0.1 Hz to 7.5 kHz
 - Required pulse width: >25 μ s for electrical positive, >67 μ s for electrical negative
- Accuracy, frequency: 0.05% of measurement value (typically 0.01% up to 2.5 kHz)
- Pulse counting

Signal processing – condition monitoring

- Time waveform
- Vector analysis with circular alarms
- FFT: 100 to 6 400-lines
- SKF Acceleration Enveloping and DPE
- Integration / differentiation in frequency domain
- Averaging (spectra, CTA and TSA)

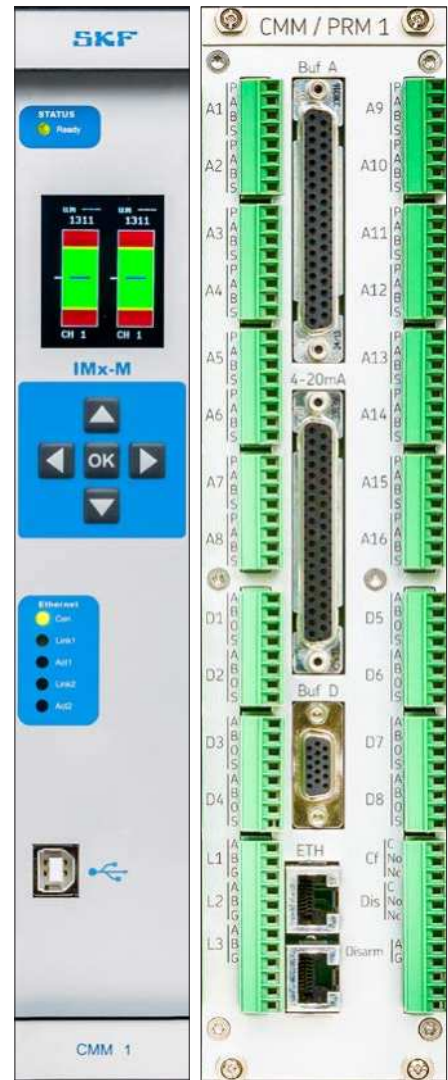

CMON 2103

CMON 2118

- Window function: Hanning and Uniform
- Mathematical expressions
- Multi-parameter gated sampling (control by speed and / or secondary input)
- Dynamic alarm levels, active range determined on multiple parameters
- Data storage on time, event or alarm condition
- Data buffering in flash memory when communication link is down
- Detection of sensor and cable fault
- Watchdog and self testing

Protection LCD and keypad

- Set-up menu
- Bargraph
- Buffered output front selection
- Channel values

Interface

- Ethernet: 10/100 Mbit RJ45, TCP/IP
- Built-in two port data switch, 10/100 Base-T
- USB service interface

On-board data storage (typical, per module)

- 1 400 latest events
- 13 000 vibration trend values
- 1 000 spectra (400-lines)

CMON 2103 Condition Monitoring module (front view)

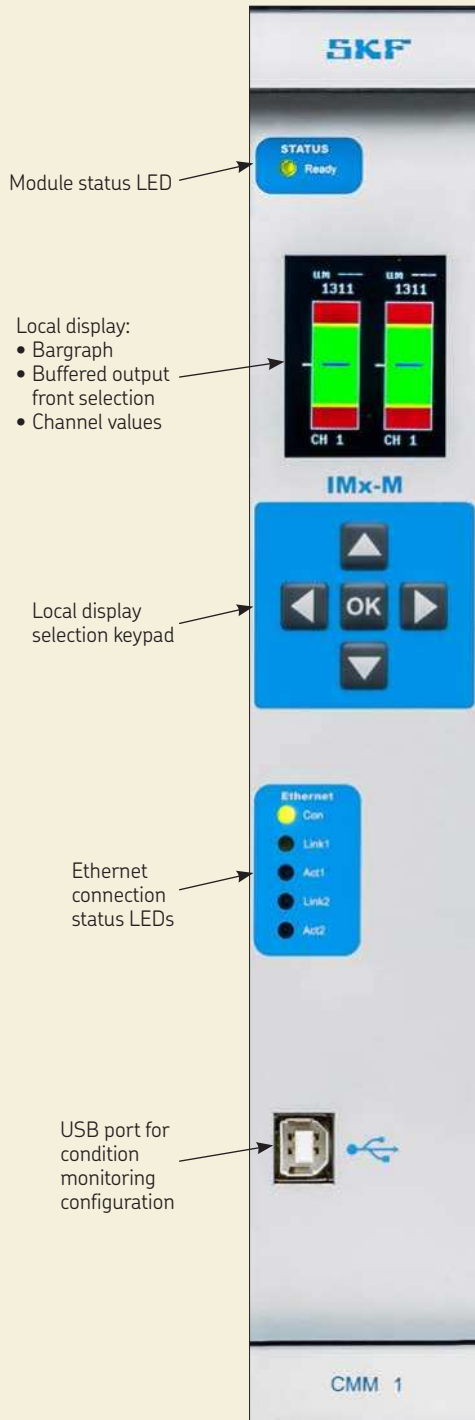

CMON 2118 Condition Monitoring and Machine Protection module pair, input / output connector board (rear view)

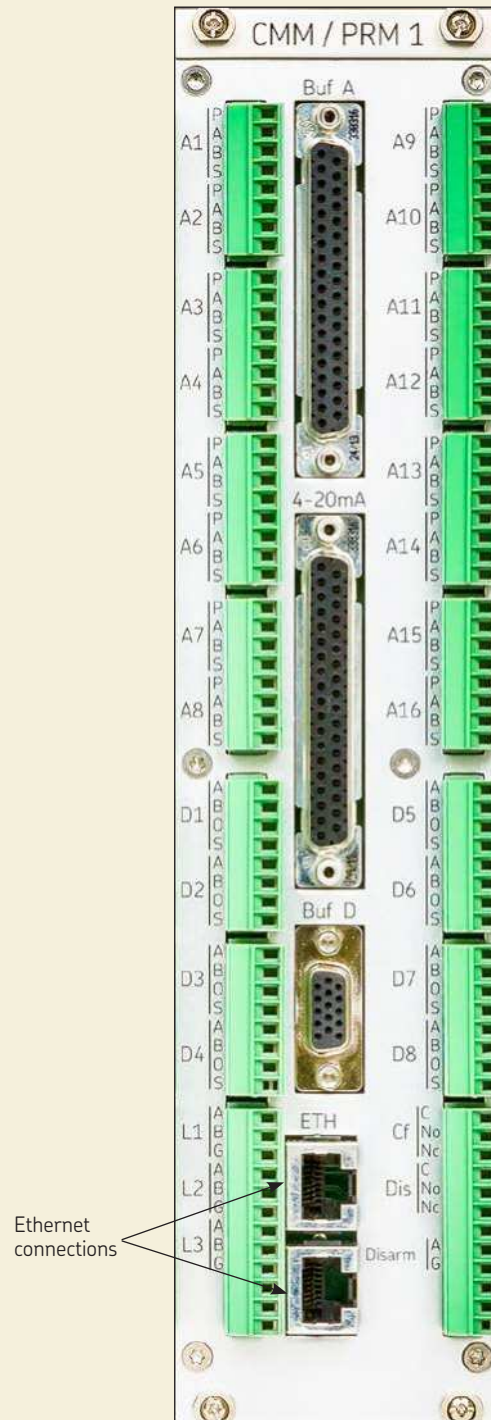

CMON 2109

Relay module

Key features – machine protection

- 32 relays per module (28 SPDT, 4 DPDT)
- Up to three modules per rack
- Software configurable
- Flexible relay assignment
- On board voting logic
- Voting across protection modules
- Redundant operation
- Normally open / normally closed
- Normally energized / de-energized (user-selectable)
- Latching/non-latching

Each CMON 2109 machine protection relay module has 32 relays, for a maximum of 96 relays per 19-inch rack. All channels can access all relays.

The relay module is software configurable, with no need for DIP switch settings. Relay logic is flexible AND / OR / MAJORITY voting.

Technical data

Relay specification

- Maximum switching voltage: Up to 60 V DC, 30 V RMS/42.4 V peak
- Maximum switching current: Maximum 2 A peak, maximum 1 A continuously
- Maximum switching capacity: 60 W, 62.5 VA
- Mechanical endurance: Typical 10^8 operations
- Electrical endurance: Minimum 10^5 operations at maximum rating
- Category of protection: Hermetically sealed (RTV)

Physical

- 19-inch rack mounted
- Size: 6U high, 4TE wide
- Weight: 0,4 kg (14 oz.)

Environmental

- Temperature range: -20 to $+65$ °C (-4 to $+149$ °F)
- Humidity: 95% relative humidity (non-condensing)

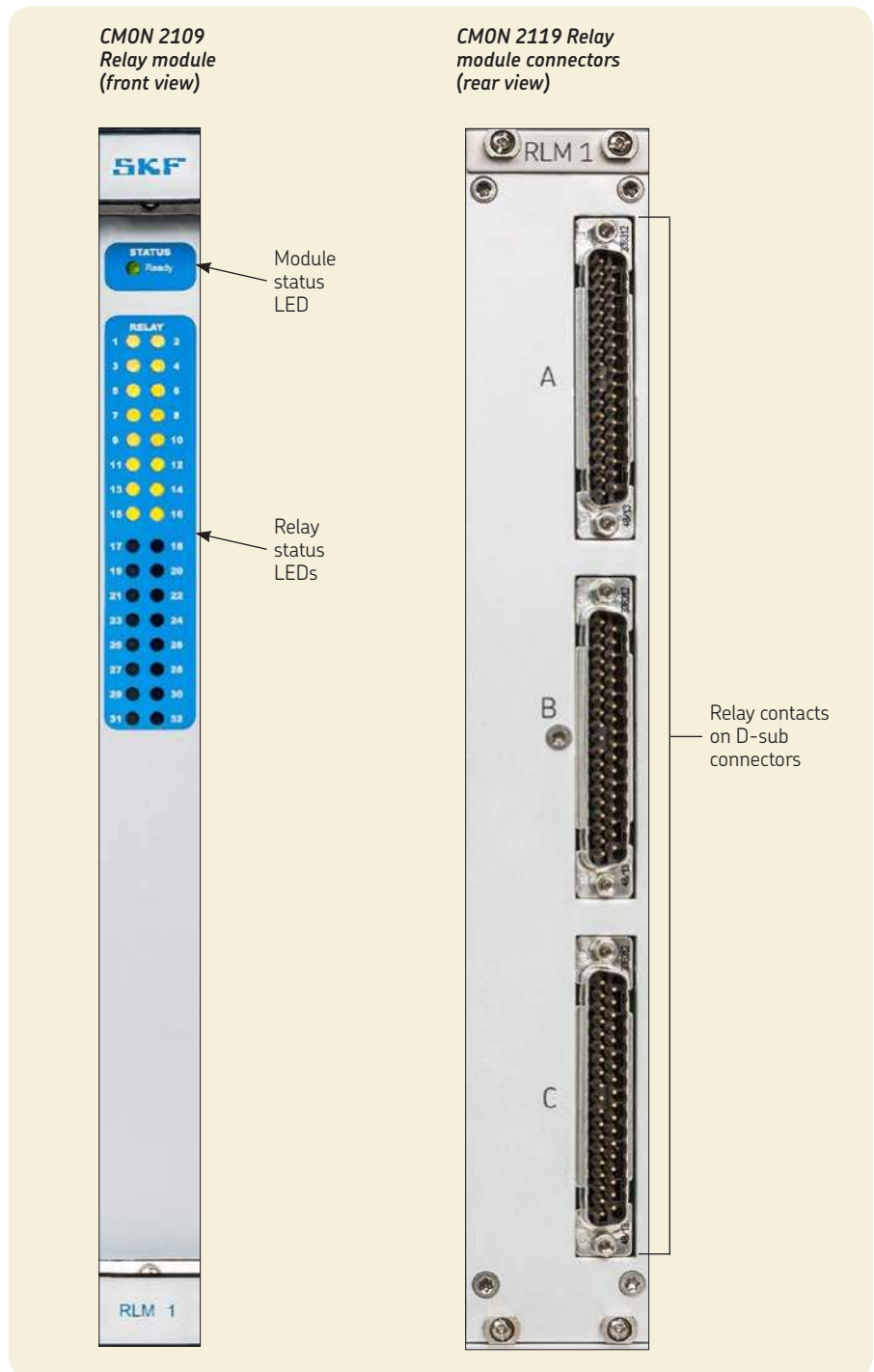

CMON 2202

Power Supply module

Key features

- Four individual LED status indicators (one per Machine Protection and Condition Monitoring module slot pair)
- Supports power supply redundancy

The CMON 2202 supplies power to the various modules in the SKF Multilog IMx-M rack. The power supply accepts AC (90 to 240 V AC, 47 to 63 Hz). A single power supply can support a fully loaded rack. A second power supply can provide redundancy.

Technical data

Physical

- 19-inch rack mounted
- Size: 6U high, 12TE wide
- Weight: 1,6 kg (56 oz.)

Environmental

- Temperature range: -20 to +65 °C (-4 to +149 °F)
- Humidity: 95% relative humidity (non-condensing)

Power supply

- 90 to 240 V AC, 47 to 63 Hz input voltage
- Maximum power consumption: 300 W
- Redundant option, individual mains terminals
- Thermal and short circuit protection
- Self-monitoring via PRM status information and Relay Output option

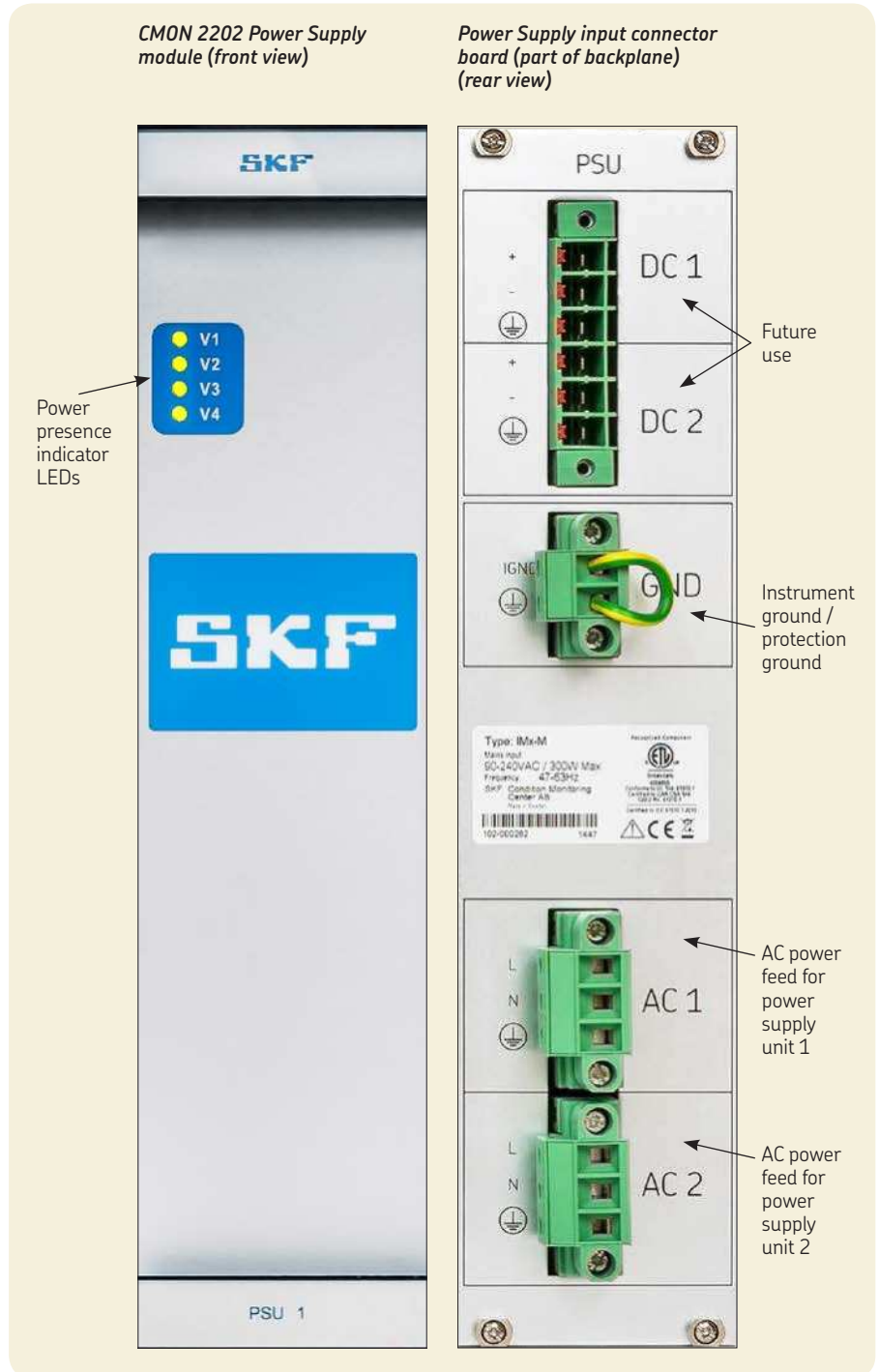

Mechanism for easy module extraction and custom label holders

Extracting modules

Simple extracting mechanisms with convenient handles located on the top and bottom of each module makes it easy to extract and replace modules.

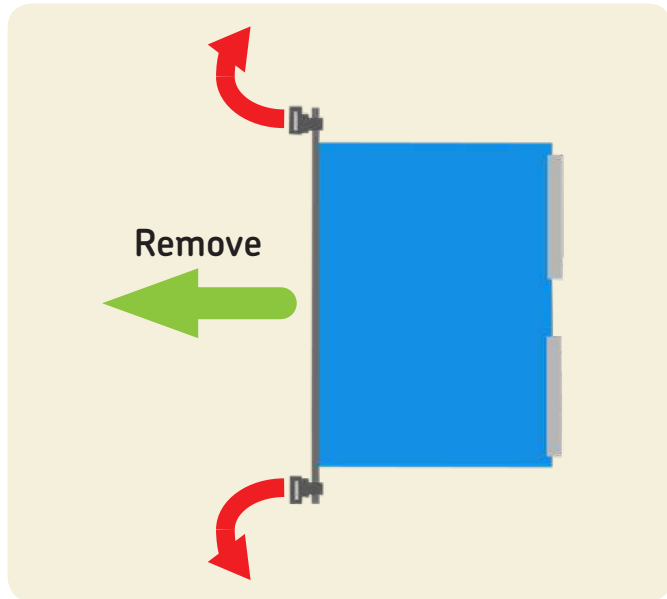

Custom label holders

Simply slide out the protective plastic cover, place your own label, and slide the plastic cover back to secure the label in place. Both top and bottom handles can be used for customised labelling.



SKF Multilog IMx-M Manager

SKF Multilog IMx-M Manager (included with every unit), is a “stand alone” software tool for configuring and setting up the SKF Multilog IMx-M. It provides a user friendly interface with logically ordered function and module layout, to simplify the task of configuring the SKF Multilog IMx-M. It includes test function, live displays, alarm / alert and measurement limits visualization and has built-in rules that will warn you if settings are out of range or unsafe. It supports the SKF Maintenance Mode which allows you to test all inputs on the system with a live display, aid in verifying relays and their corresponding logic, and allows you to generate a SAT (Site Acceptance Test) report.

Main function and features

- Allows for full setup and configuration of the SKF Multilog IMx-M
- USB interface for initial network setup
- Rules for verifying all settings and pre-testing of a configuration (dry run)
- Supports saving configuration files to SKF @ptitude Observer database directly
- SKF Maintenance Mode with SAT report
- Live data display for verifying installation and settings
- Tools for upgrading the firmware of both Machine Protection and Condition Monitoring modules
- Hierarchy with familiar plant layout (supports multiple SKF Multilog IMx-M units)

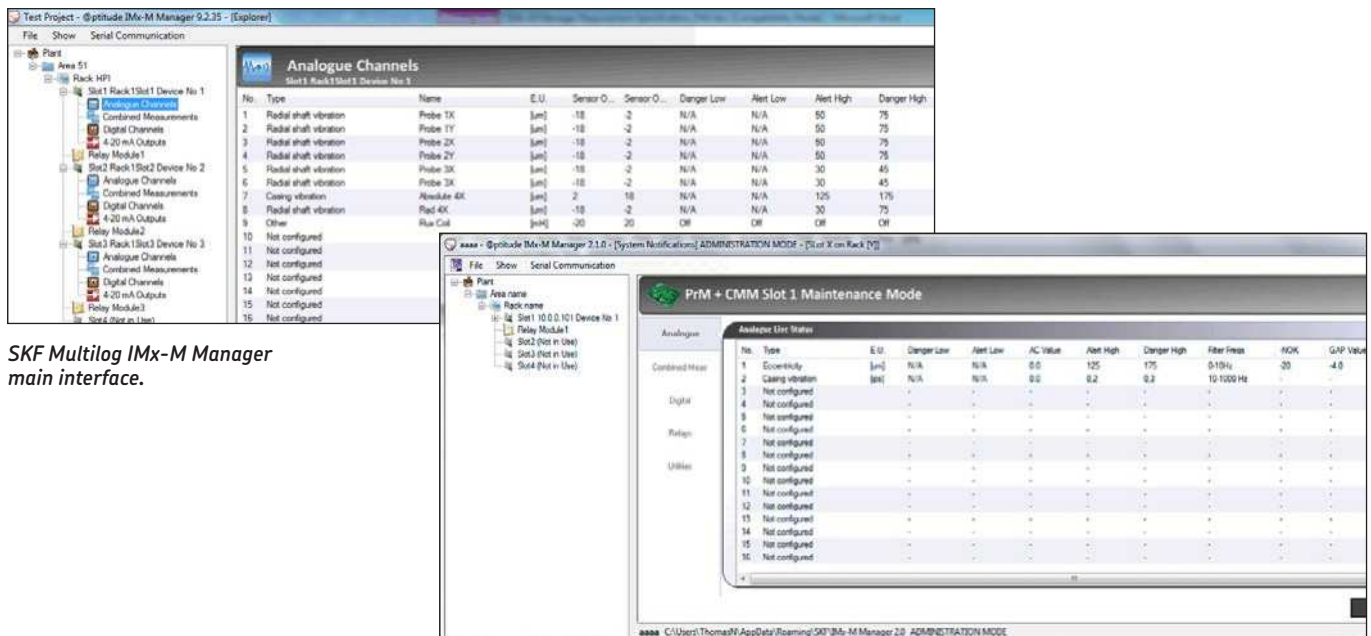

SKF Multilog IMx-M Manager main interface.

Maintenance mode.



Measurement limits and configuration visualization.



SAT report.

Scalable plantwide solutions for machinery monitoring

Typical non-hazardous area installation

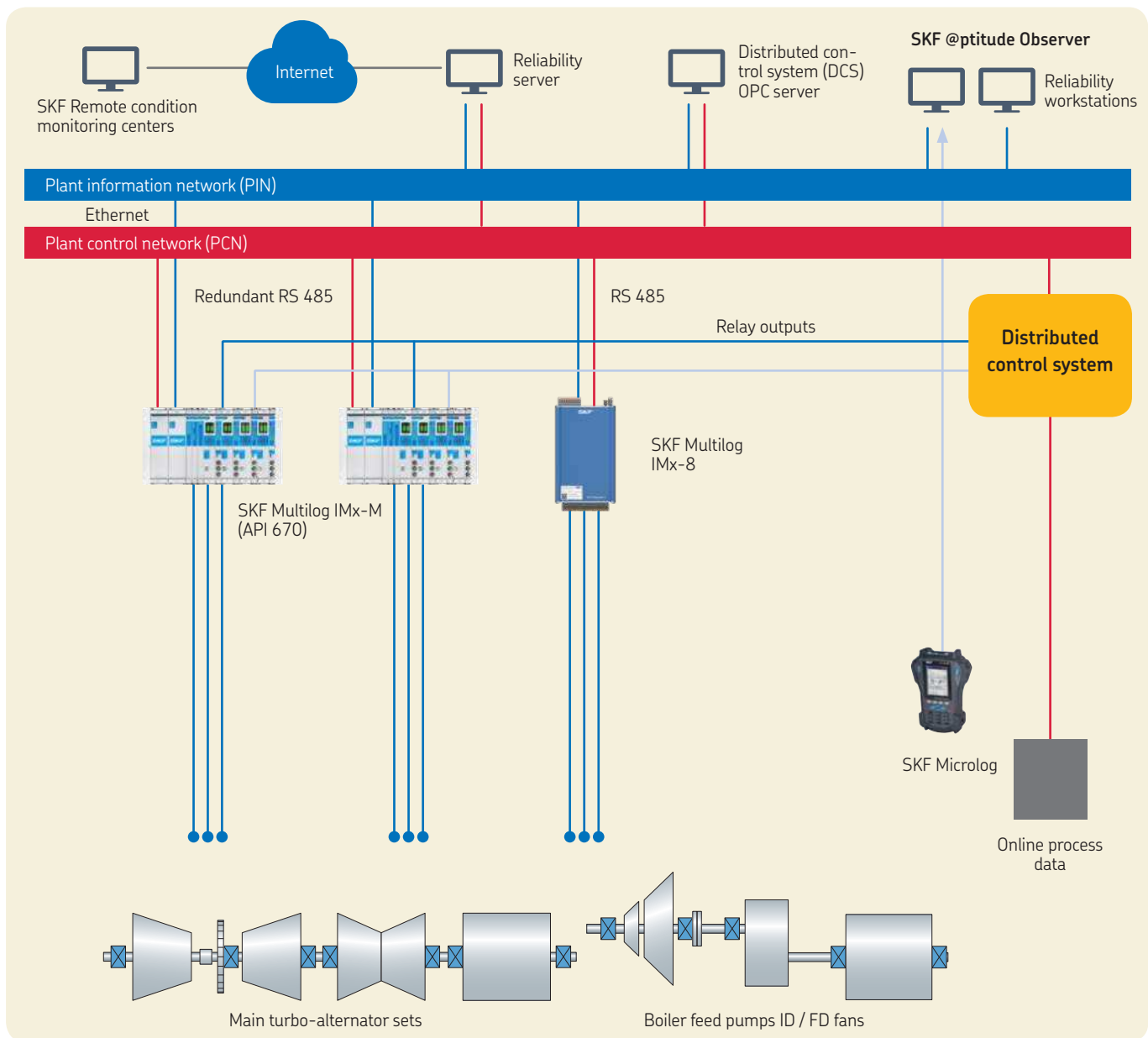

SKF offers comprehensive solutions for protection and condition monitoring of all classes of rotating machinery, encompassing a variety of architectures that can be scaled to optimize functionality with respect to total installed cost.

SKF Multilog On-line System IMx-M

Provides a 19-inch rack format solution that is located in a non-hazardous area such as an instrument or control room. The SKF Multilog IMx-M combines high functionality with high channel density, which leads to lower requirements for a cabinet and associated infrastructure.

SKF Multilog On-line System IMx-8

A multi-channel, on-line condition monitoring device suitable for field installation in non-hazardous areas. The SKF Multilog IMx-8 provides fully automated monitoring and analysis capabilities and is best suited for semi-critical and balance of plant equipment.

Scalable plantwide solutions for machinery monitoring

Typical hazardous area installation

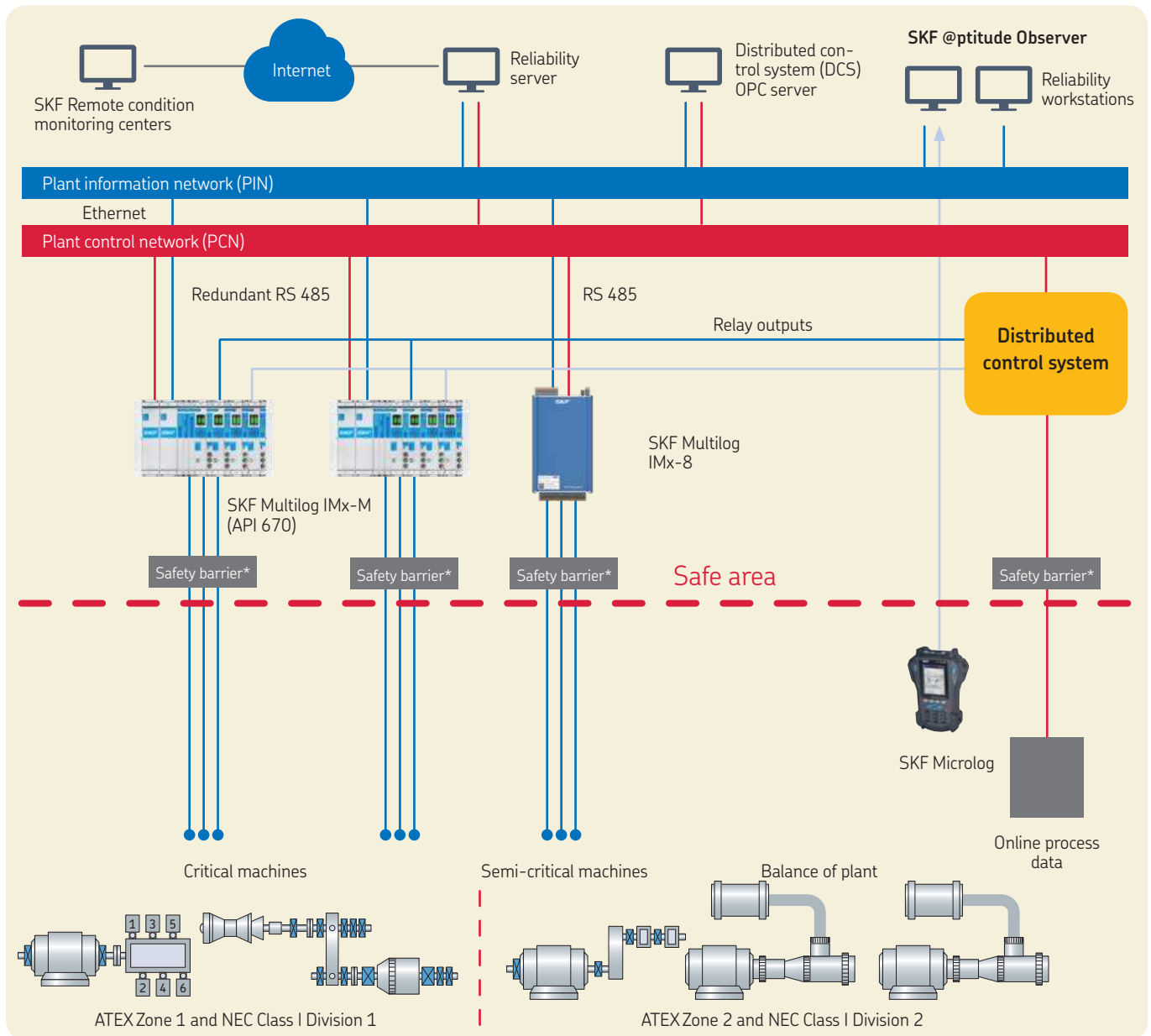

* NOTE: An appropriate safety barrier or isolator for the circuit type, hazardous area device and classification, is required.

SKF Microlog Analyzer

SKF Microlog portable instruments offer a comprehensive range of predictive maintenance tools.

SKF @ptitude Observer

Predictive maintenance software platform that brings all data from field instruments together for processing into actionable information regarding equipment reliability. SKF @ptitude Observer organises the machine information database and provides a wide range of data displays and analysis tools. The powerful machine diagnostics feature includes standard rules for common machine faults. User defined diagnosis rules can also be easily implemented.

Analytical tools from SKF @ptitude Observer software

SKF @ptitude Observer is a comprehensive software solution with powerful diagnostic and analytical capabilities. SKF @ptitude Observer provides fast, efficient and reliable storage, analysis, and retrieval of complex asset information and makes the information accessible throughout your organization. SKF @ptitude Observer easily scales to your specific needs, whether it is operator inspection rounds, condition monitoring data collection or in-depth vibration analysis and expert advice.

SKF @ptitude Observer allows your operations, maintenance and reliability staff to view data from different sources using the same application and communicate information to other departments in a customisable format.

SKF @ptitude Observer integrates the range of SKF on-line and off-line data collection devices into one enterprise-wide software platform.

NOTE: Latest version supporting IMx-M is @0 10.2

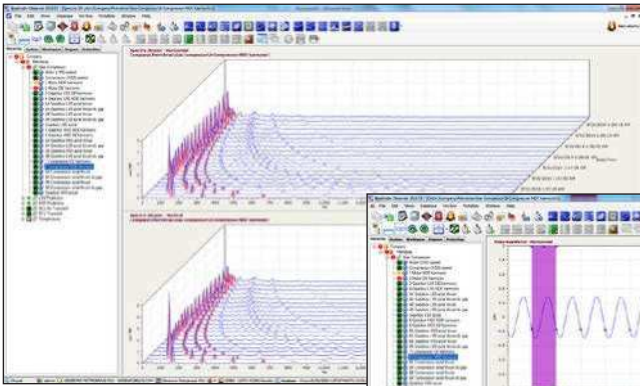

Spectra plot.

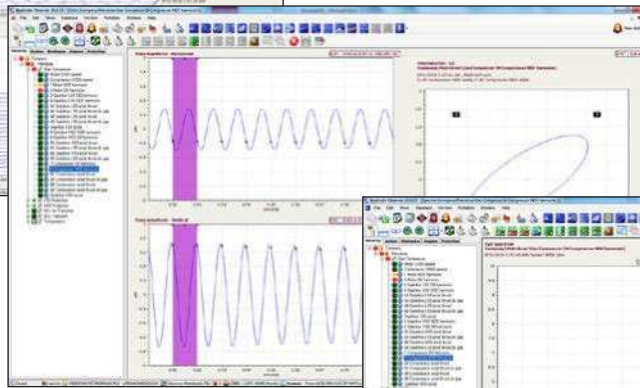

Time waveform plot.

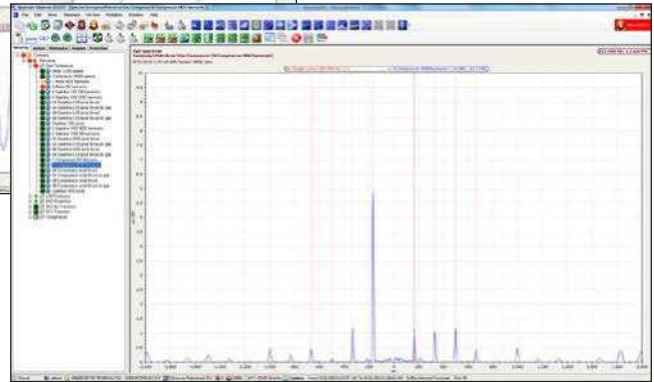

Full Spectrum plot.

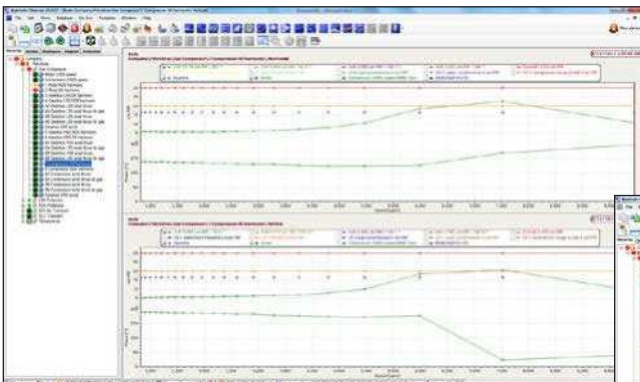

Bode plot.

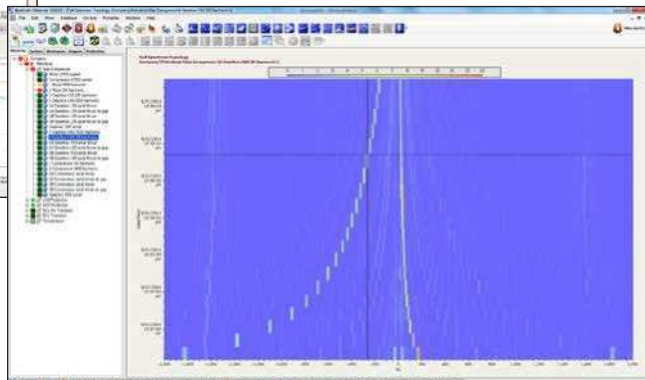

Full Spectrum Topology plot.

Transducer systems



Eddy current probe systems

SKF offers a full range of API 670 compliant non-contacting displacement sensors (Eddy current probes) for use in critical machinery, with CSA and ATEX agency approvals.

CMSS 75 series, 5 mm eddy probe system

- 5 mm tip, 2 mm (80 mil) measurement range
- 5 m or 9 m system length
- CMSS 75 Eddy current probe
- CMSS 785 Driver
- CMSS 985 Extension cable

CMSS 78 series, 8 mm eddy probe system

- 8 mm tip, 2 mm (80 mil) measurement range
- 5 m or 9 m system length
- CMSS 78 Eddy current probe
- CMSS 785 Driver
- CMSS 985 Extension cable



Accelerometers and velocity sensors

SKF offers a full range of piezoelectric casing vibration sensors, including models with CSA, FM and ATEX agency approvals.

General purpose industrial accelerometers

- CMSS 2100 Top exit, industrial accelerometer
- CMSS 2200 Low profile, side exit, industrial accelerometer
- CMSS 2106 High temperature, top exit, industrial accelerometer
- CMSS 2207 High temperature, low profile, side exit, industrial accelerometer
- CMSS 793V Piezoelectric industrial velocity sensor

Agency approved accelerometers*

- CMSS 786A-IS and CMSS 786A-D2 CSA and ATEX approved, intrinsically safe, general purpose, top exit, industrial accelerometer
- CMSS 787A-IS and CMSS 787A-D2 CSA and ATEX approved, intrinsically safe, general purpose, low profile, side exit, industrial accelerometer
- CMSS 793-CA CSA approved, intrinsically safe, general purpose, top exit, industrial accelerometer
- CMSS 793-EE ATEX approved, intrinsically safe, general purpose, top exit, industrial accelerometer
- CMSS 793-FM Factory Mutual approved, intrinsically safe, general purpose, top exit, industrial accelerometer
- CMSS 797-EE ATEX approved, intrinsically safe, general purpose, low profile, ring mode, industrial accelerometer

* Installation must conform to hazardous area requirements when used in this environment.

Miscellaneous

CMON 2131

SKF Multilog IMx-M blank cover plate kit (to cover slots without modules in them). The blank cover plate kit includes:

- Two (2) each, Power Supply module cover plates
- Four (4) each, Machine Protection module cover plates (front, including handles)
- Four (4) each, Condition Monitoring module plates (front, including handles)
- Four (4) each, Machine Protection plus Condition Monitoring Connector board cover plate (rear plate, example picture below)
- Three (3) each, Relay modules (front, including handles)
- Three (3) each, Relay Connector board cover plate (rear, example picture below)



Machine Protection plus Condition Monitoring Connector blank cover plate (rear)

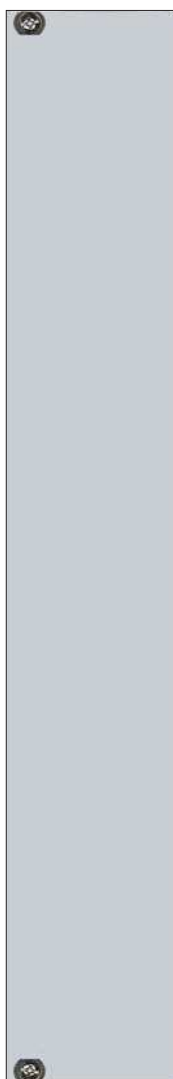

Relay module blank cover plate (rear)

CMON 2132

SKF Multilog IMx-M spare connector kit. Contains spare green terminal connectors for one Machine Protection and Condition Monitoring module pair and all connectors needed on the power supply.

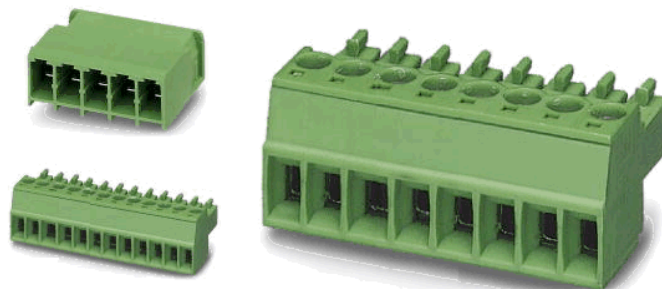

CMON 2133

Isolated USB cable set for use with the SKF Multilog IMx-M (contains two USB cables).

NOTE: One (1) set each, CMON 2133 is included with every SKF Multilog IMx-M shipped.



Isolator USB connector cable.



Isolator mini USB connector cable.

Ordering information

SKF Multilog On-line System IMx-M (necessary rear connector boards and SKF Multilog IMx-M Manager included)

Part number		CMON 5000-aa-b-cc
aa	Number of channels	
16	16 channels	
32	32 channels	
48	48 channels	
64	64 channels	
b	Number of power supplies	
1	1 power supply	
2	2 power supplies	
cc	Number of relays	
32	32 relays	
64	64 relays (for 32, 48 or 64 channels only)	
96	96 relays (for 48 or 64 channels only)	

For example, **CMON 5000-16-2-32**: SKF Multilog IMx-M rack with 16 channels, 2 power supplies, 32 relays and the necessary rear connector boards.

Standard rack part numbers for the SKF Multilog On-line System IMx-M (necessary rear connector boards and SKF Multilog IMx-M Manager included)

Standard rack part numbers	Description – SKF Multilog IMx-M rack with:
CMON 5000-16-2-0	16 channels, 2 power supplies
CMON 5000-16-2-32	16 channels, 2 power supplies, 32 relays
CMON 5000-32-2-0	32 channels, 2 power supplies
CMON 5000-32-2-32	32 channels, 2 power supplies, 32 relays
CMON 5000-32-2-64	32 channels, 2 power supplies, 64 relays
CMON 5000-48-2-0	48 channels, 2 power supplies
CMON 5000-48-2-32	48 channels, 2 power supplies, 32 relays
CMON 5000-48-2-64	48 channels, 2 power supplies, 64 relays
CMON 5000-48-2-96	48 channels, 2 power supplies, 96 relays
CMON 5000-64-2-0	64 channels, 2 power supplies
CMON 5000-64-2-32	64 channels, 2 power supplies, 32 relays
CMON 5000-64-2-64	64 channels, 2 power supplies, 64 relays
CMON 5000-64-2-96	64 channels, 2 power supplies, 96 relays

Contact the Customer Service Group at CSG-Lulea@skf.com for other CMON 5000 part numbers.

Add-on modules:

- **CMON 5000-16-AN**: 16 channel Machine Protection and Condition Monitoring add-on module pair, including rear connector board (CMON 2118)
- **CMON 5000-32-RE**: 32 channel Relay add-on module including rear, relay connector board (CMON 2119)

Components:

- **CMON 2007**: 19-inch rack enclosure including backplane and power supply input connector board
- **CMON 2102**: Machine Protection module (maximum four per rack)
- **CMON 2103**: Condition Monitoring module (one per CMON 2102)
- **CMON 2109**: Relay module
- **CMON 2118**: Machine Protection and Condition Monitoring pair input / output rear connector board (maximum four per rack)
- **CMON 2119**: Relay module rear connector board (one per installed relay module)
- **CMON 2202**: Power Supply unit (maximum two per rack)

Ordering information – accessories / spare parts

Miscellaneous

- **CMON 2131:** SKF Multilog IMx-M blank cover plate kit (to cover slots without modules in them). The blank cover plate kit includes, for the front of the rack:
 - Two (2) each, Power Supply module plates
 - Four (4) each, Machine Protection module plates
 - Four (4) each, Condition Monitoring module plates
 - Three (3) each, Relay module plates

For the rear of the rack:

 - Four (4) each, Machine Protection plus Condition Monitoring Connector board cover plates
 - Three (3) each, Relay Connector board cover plates

- **CMON 2132:** SKF Multilog IMx-M spare connector kit. Contains spare green terminal connectors for one Machine Protection and Condition Monitoring module pair and all connectors needed on the power supply.
- **CMON 2133:** Isolated USB cable set for use with the SKF Multilog IMx-M (contains two USB cables).

Installation and training

Installation and training available through your local SKF supplier or representative.

Product Support Plans (PSP)

A range of Product Support Plans is available to protect your investment. Contact your local SKF representative for additional information.

Please contact:

SKF Sverige AB

Aurorum 30, S-977 75 • Luleå, Sweden

Tel: +46 (0) 31 337 10 00 • Fax: +46 (0) 920 134 40

Web: www.skf.com/cm

© SKF, @PTITUDE, MICROLOG and MULTIOLOG are registered trademarks of the SKF Group.

All other trademarks are the property of their respective owners.

© SKF Group 2018

The contents of this publication are the copyright of the publisher and may not be reproduced (even extracts) unless prior written permission is granted. Every care has been taken to ensure the accuracy of the information contained in this publication but no liability can be accepted for any loss or damage whether direct, indirect or consequential arising out of the use of the information contained herein. SKF reserves the right to alter any part of this publication without prior notice.

Patents: US 4,768,380 · US 5,633,811 · US 5,679,900 · US 5,845,230 · US 5,852,351 · US 5,854,553 · US 5,854,994 · US 5,870,699 · US 5,907,491 · US 5,992,237 · US 6,006,164 · US 6,124,692 · US 6,138,078 · US 6,199,422 · US 6,202,491 · US 6,275,781 · US 6,301,514 · US 6,437,692 · US 6,489,884 · US 6,513,386 · US 6,633,822 · US 6,789,025 · US 6,792,360 · US 7,103,511 · US 7,697,492 · WO/2003/048714

PUB CM/P8 11416/5 EN · November 2018

