

Hand-operated centralized lubrication pumps

HP 4, HP 15, HPG 4, HPG 15, HPG 15 K

HP-500W, HP-500W SSV

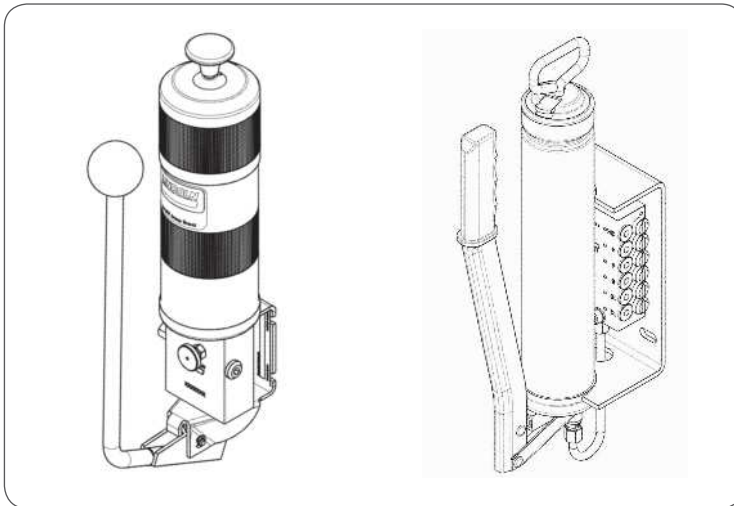

Version 02



Legal Disclosure

Warranty

The instructions do not contain any information on the warranty. This can be found in the general terms and conditions.

Copyright

© SKF. All rights reserved.

Manufacturer

SKF Lubrication Systems Germany GmbH
Walldorf Plant
Heinrich-Hertz-Str. 2-8
DE - 69190 Walldorf, Germany
Phone: +49 (0) 6227 33-0
Fax: +49 (0) 6227 33-259
E-mail: Lubrication-germany@skf.com
www.skf.com/lubrication

Sales and Service Regions

[Europe / Africa / Middle East/ India](#)
SKF Lubrication Systems Germany GmbH

[Americas / Asia / Pacific](#)
Lincoln Industrial, One Lincoln Way
St. Louis, MO 63120-1578 USA
Phone: +1.314.679.4200
Fax: +1.800.424.5359
E-mail: lincoln@lincolnindustrial.com
www.lincolnindustrial.com
www.skf.com/lubrication

Table of contents

Legal Disclosure	2	2. Lubricants	12	6. Assembly	20
Table of contents	3	2.1 General information	12	6.1 General information	20
Explanation of symbols and signs	5	2.2 Selection of lubricants	12	6.2 Set-up and attachment	20
1. Safety instructions	7	2.3 Approved lubricants	13	6.3 Minimum assembly dimensions	
1.1 General safety instructions	7	2.4 Lubricants and the environment	14	HP 4-HPG 15 (K)	21
1.2 General behaviour when handling the product	7	2.5 Lubricant hazards	14	6.4 Connection dimensions	
1.3 Qualified technical personnel	8	3. Overview/ functional description	15	HP 4-HPG 15 (K)	22
1.4 System pressure hazard	9	3.1 HP 4-HPG 15 (K)	15	6.5 Minimum assembly dimensions	
1.5 Operation	9	3.2 HP-500W (SSV)	16	HP-500W (SSV)	23
1.6 Assembly, maintenance, malfunctions, shutdown, disposal	9	3.3 Typical configurations of a manual centralized lubrication system	17	6.6 Connection dimensions	
1.7 Intended use	10			HP-500W (SSV)	24
1.8 Foreseeable misuse	10	4. Technical data	18	7. Start up	25
1.9 Disclaimer of liability	10			HP 4, HP 15, HPG 15, HPG 15 K	25
1.10 Referenced documents	10	5. Delivery, returns and storage	19	7.1 Operating the pump	25
1.11 Residual risks	11	5.1 Delivery	19	7.2 Modifying the output volume in case of the HPG pumps	25
		5.2 Returns	19	7.3 Filling via hydraulic lubrication fitting	26
		5.3 Storage	19	7.4 Filling via reservoir cover	26
		5.4 General notes related to the storage	19	7.5 Venting	27



HP-500W, HP-500W SSV	28	10.1 HP 4 - HPG 15 (K)	33
7.6 Operating the pump	28	10.2 HP-500W (SSV)	34
7.7 Modifying the output volume in case of HP-500W SSV pumps	28		
7.8 Inserting a standard cartridge (400g) into HP-500W (SSV) pumps	29	11. Spare parts	35
7.9 Filling out of grease container	30	11.1 HP 4-HPG 15 (K) pumps	35
8. Operation, shutdown and disposal	31	11.2 HP-500W (SSV) pumps and SSV metering devices	35
8.1 General information	31	11.3 Closure screws	35
8.2 Temporary shutdown	31	11.4 Outlet fittings	35
8.3 Shutdown and disposal	31	11.5 Connecting tube for HP-500W SSV pumps	35
9. Maintenance and cleaning	32	11.6 Reservoir assembly for HP and HPG pumps	36
9.1 General information	32	11.7 Hand lever and ball head for HP and HPG pumps	36
9.2 Cleaning	32	11.8 Bracket with bottom for HP and HPG pumps	36
9.3 Maintenance	32	11.9 Pump body for HPG pumps	36
10. Troubleshooting	33		

Notes

Explanations of symbols and signs

You will find these symbols, which warn of specific dangers to persons, material assets, or the environment, next to all safety instructions

in these operating instructions. Please heed these instructions and proceed with special care in such cases. Please forward all safety instructions to other users.

	Warning level	Consequences	Probability
	DANGER	Death/ serious injury	Immediate
	WARNING	Serious injury	Possible
	CAUTION	Minor injury	Possible
	ATTENTION	Property damage	Possible

Symbol	Meaning
●	Prompts an action
○	Used for itemizing
	Refers to other facts, causes, or consequences
→	Provides additional information within procedures

Symbols used	
Symbol	Meaning
	General warning
	Electrical component hazard Electrical shock hazard
	Slipping hazard
	Hazard from hot surfaces
	Hazard from unintended entry
	Hand injuries / crushing hazard
	Pressure injection hazard
	Wear personal protective equipment (goggles)
	Note
	Environmentally sound disposal
	Dispose of used electric and electronic devices in an environmentally sound manner

Abbreviations and conversion factors

Abbreviations

re.	regarding	oz.	Ounce
approx.	approximately	psi	pounds per square inch
°C	degrees Celsius	rh	relative humidity
cu.in	cubic inch	s	second
dB (A)	sound pressure level	sq.in.	square inch
i.e.	that is	e.g.	for example
etc.	et cetera	>	greater than
poss.	possibly	<	less than
°F	degrees Fahrenheit	±	plus or minus
fl.ou	fluid ounce	∅	diameter
fpsec	feet per second	mph	miles per hour
gal.	gallon	assy.	assembly
hp	horse power	rpm	revolutions per minute
in.	inch		
incl.	including	Conversion factors	
K	Kelvin	Length	1 mm = 0.03937 in.
kg	kilogram	Area	1 cm ² = 0.155 sq.in
kp	kilopond	Volume	1 ml = 0.0352 fl.oz.
kW	kilowatt		w
l	litre	Mass	1 kg = 2.205 lbs
lb.	pound		1 g = 0.03527 oz.
max.	maximum	Density	1 kg/cm ³ = 8.3454 lb./gal(US)
min.	minimum		1 kg/cm ³ = 0.03613 lb./cu.in.
min	minute	Force	1 N = 0.10197 kp
ml	millilitre	Speed	1 m/s = 3.28084 fpsec.
ml/d	millilitre per day		1 m/s = 2.23694 mph
mm	millimeter	Acceleration	1 m/s ² = 3.28084 ft./s ²
N	Newton	Pressure	1 bar = 14,5 psi
Nm	Newtonmeter	Temperature	°C = (°F-32) x 5/9
		Power	1 kW = 1.34109 hp

1. Safety instructions

1.1 General safety instructions

The operator must ensure that the lifecycle manual is read and understood by all persons tasked with working on the product or who supervise or instruct such persons.

The operator must also ensure that the staff fully understands the content of the lifecycle manual.

The described product was manufactured according to the state of the art. Risks may, however, arise from its usage and may result in harm to persons or damage to material assets.

Any malfunctions which may affect safety must be remedied immediately. In addition to the lifecycle manual, general statutory regulations and other regulations for accident prevention and environmental protection must be observed and applied.

1.2 General behaviour when handling the product

The product may only be used in awareness of the potential dangers, in proper technical condition, and according to the information in these instructions.

- Technical personnel must familiarize themselves with the functions and operation of the product. The specified assembly and operating steps and their sequences must be observed.
- Any unclear points regarding proper condition or correct assembly/ operation must be clarified. Operation is prohibited until issues have been clarified.
- Unauthorized persons must be kept away from the product.
- All safety regulations and in-house instructions relevant to the particular task must be observed.

- Responsibilities for different activities must be clearly defined and observed. Uncertainty seriously endangers safety.
- Protective and safety mechanisms must not be removed, modified, or disabled during operation and must be checked for proper function and completeness at regular intervals. If protective and safety mechanisms must be removed, they must be installed immediately following conclusion of work and then checked for proper function.
- Any malfunctions that occur must be resolved according to responsibility. The operator of the system/ machine must be notified in case of malfunctions outside the scope of responsibility.
- Wear personal protective equipment.
- Observe the particular safety data sheets when handling lubricants.

1.3 Qualified technical personnel

Only qualified technical personnel may install, operate, maintain, and repair the products described. Technical personnel are persons who have been trained, assigned, and instructed by the operator of the final product into which the described product is incorporated.



Such persons are familiar with the relevant standards, rules, accident prevention regulations, and assembly conditions as a result of their training, experience, and instruction. They are qualified to carry out the required activities and in doing so recognize and avoid any potential hazards.

The operator of the final product is responsible for assigning tasks and areas of responsibility and for the responsibility and monitoring of the personnel. These areas must be precisely specified by the operator. The personnel must be trained and instructed if they do not possess the requisite knowledge.

Product training can also be performed by SKF in exchange for costs incurred.

1. Safety instructions

1.4 System pressure hazard

	WARNING
	<p>System pressure The product is pressurized during operation. Centralized lubrication systems must therefore be depressurized before starting assembly, maintenance, or repair work, or any system modifications or system repairs.</p>

1.5 Operation

The following must be observed during commissioning and operation.

- All information within this manual and the information within the referenced documents.
- All laws/ regulations that the operator must observe.

1.6 Assembly, maintenance, malfunctions, shutdown, disposal

- All relevant persons (e.g., operating personnel, supervisors) must be informed of the activity prior to the start of work. Precautionary operational measures/ work instructions must be observed.
- Ensure through suitable measures that moving/ detached parts are immobilized during the work and that no body parts can be pinched by unintended movements.
- Assemble the product only outside the operating range of moving parts, at an adequate distance from sources of heat or cold.
- Prior to performing work, the product and the machine/ system in which the product is or will be integrated must be depressurized and secured against unauthorized activation.
- All work on electrical components may be performed only with voltage-insulated tools.
- Ensure proper grounding of the product.
- Drill required holes only on non-critical, non-load bearing parts.
- Other units of the machine/the vehicle must not be damaged or impaired in their function by the installation of the centralized lubrication system.
- No parts of the centralized lubrication device may be subjected to torsion, shear, or bending.
- Use suitable lifting gear when working with heavy parts.
- Avoid mixing up/ incorrectly assembling disassembled parts. Label parts.

1.7 Intended use

Hand-operated pump for the supply of lubricants corresponding to the specifications stated in these Instructions within a centralized lubrication system.

1.8 Foreseeable misuse

Any usage of the product differing from the aforementioned conditions and stated purpose is strictly prohibited. Particularly prohibited are:

- Use in an explosive atmosphere.
- Use to feed/ forward/ store Group 1 dangerous fluids according to Directive 67/548/EC.
- Use to feed/ forward/ store gases, liquefied gases, dissolved gases, vapors, or fluids whose vapor pressure exceeds normal atmospheric pressure (1013 mbar) by more than 0.5 bar at their maximum permissible operating temperature.

1.9 Disclaimer of liability

The manufacturer shall not be held responsible for damages:

- Caused by inappropriate usage.
- Resulting from improper assembly, configuration, or filling.
- Resulting from improper response to malfunctions.
- Caused by unauthorized modification of system components.
- Caused by the installation of non-original SKF components or SKF spare parts.

1.10 Referenced documents

In addition to these instructions, the following documents must be observed by the respective target group:

- Operational instructions and approval rules.
- Instructions from suppliers of purchased parts.
- Safety data sheet (MSDS) of the lubricant used.
- Project planning documents and other relevant documents, if provided.

The operator must supplement these documents with applicable national regulations for the country of use. This documentation must be included if the product is sold or transferred.

1.11 Residual risks

Residual risk	Remedy
Life cycle assembly, malfunction, troubleshooting, repair, maintenance	
People slipping due to floor contamination with spilled/ leaked lubricant	<ul style="list-style-type: none"> • Exercise caution when connecting the product's hydraulic components. • Promptly apply suitable binding agents and remove the leaked /spilled lubricant. • Follow operational instructions for handling lubricants and contaminated parts.
Tearing / damage to lines when installed on moving machine components	<ul style="list-style-type: none"> • If possible, do not install on moving parts; if this cannot be avoided, use flexible hose lines.
Lubricant spray out due to faulty component fitting/ line connection	<ul style="list-style-type: none"> • Use hydraulic connections and lines suitable for the indicated pressures. These must be checked for proper connection and for damage prior to commissioning.

2. Lubricants

2.1 General information

ATTENTION

All products may be used only for their intended purpose and in accordance with the life cycle instructions.

Intended use is the use of the products for the purpose of providing centralized lubrication/ lubrication of bearings and friction points with lubricants within the physical usage limits which can be found in the documentation for the device, e.g., operating instructions and the product descriptions, e.g. technical drawings and catalogs. Particular attention is called to the fact that hazardous materials of any kind, especially those materials classified as hazardous by EC Directive 67/548/EEC, Article 2, Para. 2, may only be filled into SKF centralized lubrication systems and components and delivered and/ or distributed with such systems and components after consulting with and obtain-

ing written approval from SKF Lubrication Systems.

No products manufactured by SKF Lubrication Systems are approved for use in conjunction with gases, liquefied gases, pressurized gases in solution, vapors, or such fluids whose vapor pressure exceeds normal atmospheric pressure (1013 mbar) by more than 0.5 bar at their maximum permissible temperature.

Other media which are neither lubricant nor hazardous substance may only be fed after consultation with and written approval from SKF Lubrication Systems.

SKF Lubrication Systems considers lubricants to be an element of system design and must always be factored into the selection of components and the design of centralized lubrication systems. The lubricating properties of the lubricants are critically important in making these selections.

2.2 Selection of lubricants

ATTENTION

Observe the instructions from the machine manufacturer regarding the lubricants that are to be used. The amount of lubricant required at the lube point is specified by the bearing or machine manufacturer. It must be ensured that the required lubricant volume is provided to the lubrication point. The lubrication point may otherwise not receive adequate lubrication, which can lead to damage and failure of the bearing.

Selection of a lubricant suitable for the lubrication task is made by the machine/ system manufacturer and/or the operator of the machine/ system in cooperation with the lubricant supplier.

When selecting a lubricant, the type of bearings/ friction points, the expected load during operation, and the anticipated ambient conditions must be taken into account. All economic and environmental aspects must also be considered.

2.3 Approved lubricants

ATTENTION

If required SKF can help customers to select suitable components for feeding the selected lubricant and to plan and design their centralized lubrication system.

Please contact SKF Lubrication Systems if you have further questions regarding lubricants. It is possible for lubricants to be tested in the company's laboratory for their suitability for pumping in centralized lubrication systems (e.g. „bleeding“). You can request an overview of the lubricant tests offered by SKF Lubrication Systems from the company's Service department.

ATTENTION

Only lubricants approved for the product may be used. Unsuitable lubricants can lead to failure of the product and to property damage.

ATTENTION

Different lubricants must not be mixed. Doing so can cause damage and require costly and complicated cleaning of the product/lubrication system. It is recommended that an indication of the lubricant in use be attached to the lubricant reservoir in order to prevent accidental mixing of lubricants.

The product described here can be operated using lubricants that meet the specifications in the technical data. Depending on the product design, these lubricants may be oils, fluid greases, or greases.

Mineral, synthetic, and/ or and rapidly biodegradable oils and base oils can be used. Consistency agents and additives may be added depending on the operating conditions.

Note that in rare cases there may be lubricants whose properties are within permissible limit values but whose other characteristics render them unsuitable for use in centralized lubrication systems. For example, synthetic lubricants may be incompatible with elastomers.

2.4 Lubricants and the environment





ATTENTION

Lubricants may pollute ground and waters. Lubricants have to be handled and disposed of properly. Relevant applicable regulations and laws regarding the disposal of lubricants must be observed.

It is important to note that lubricants are environmentally hazardous, flammable substances which require special precautionary measures during transport, storage, and processing. Consult the safety data sheet from the lubricant manufacturer for information regarding transport, storage, processing, and environmental hazards of the lubricant that will be used.

The safety data sheet for a lubricant can be requested from the lubricant manufacturer.

2.5 Lubricant hazards

	<table border="1"> <tr> <td data-bbox="669 279 727 342">  </td> <td data-bbox="727 279 1008 342"> WARNING </td> </tr> <tr> <td colspan="2" data-bbox="669 342 1008 559"> Risk of slipping and injury Leaking lubricant is hazardous due to the risk of slipping and injury. Leaks must be sealed off without delay. </td> </tr> </table>		WARNING	Risk of slipping and injury Leaking lubricant is hazardous due to the risk of slipping and injury. Leaks must be sealed off without delay.	
	WARNING				
Risk of slipping and injury Leaking lubricant is hazardous due to the risk of slipping and injury. Leaks must be sealed off without delay.					

3. Overview/ functional description

3.1 HP 4 - HPG 15 (K)

1 Piston rod

Serves as filling level indicator and when filling the reservoir from a grease container to suck in the lubricant.

2 Reservoir

Stockpile of lubricant.

3 Hand lever

Serves to pump the lubricant.

4 Metering device

Distributes lubricant after actuating the hand lever. In the case of HPG 15 K pumps the function of the metering device is indicated by an indicator pin.

5 Hydraulic lubrication fitting (covered)

On the bottom side of the reservoir. Serves to fill the reservoir via transfer pump.

6 Fastening

Serves to install the pump at the place of use.

7 Vent valve

Serves to vent the pump after the filling procedure.

8 Outlet

Connects the pump with the lubricant feed lines or downstream metering devices.

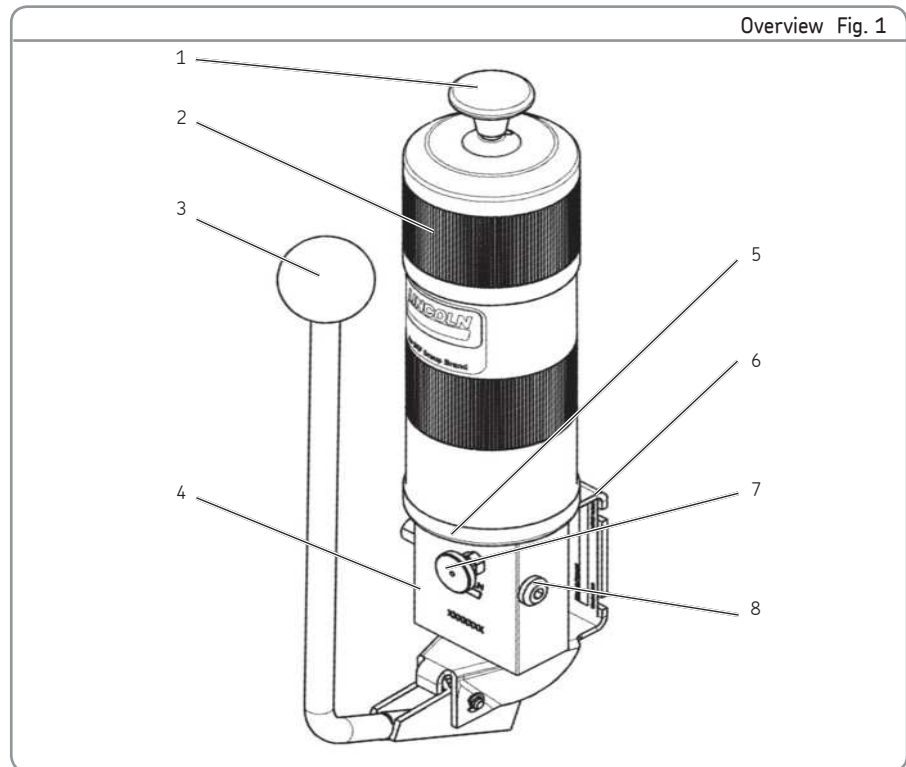

3.2 HP-500W (SSV)

1 Piston rod

Serves as filling level indicator and when filling the reservoir from a grease container to suck in the lubricant.

2 Reservoir

Stockpile of lubricant or lubricant cartridge.

3 Hand lever

Serves to pump the lubricant.

4 SSV metering device in case of HP-500W SSV pumps

Distributes lubricant to the connected lubricant feed lines after actuating the hand lever.

5 Pump outlet

Connects the pump with the lubricant feed line (HP-500W) or with the SSV progressive metering device (HP-500W SSV).

6 Fastening

Serves to install the pump at the place of use.

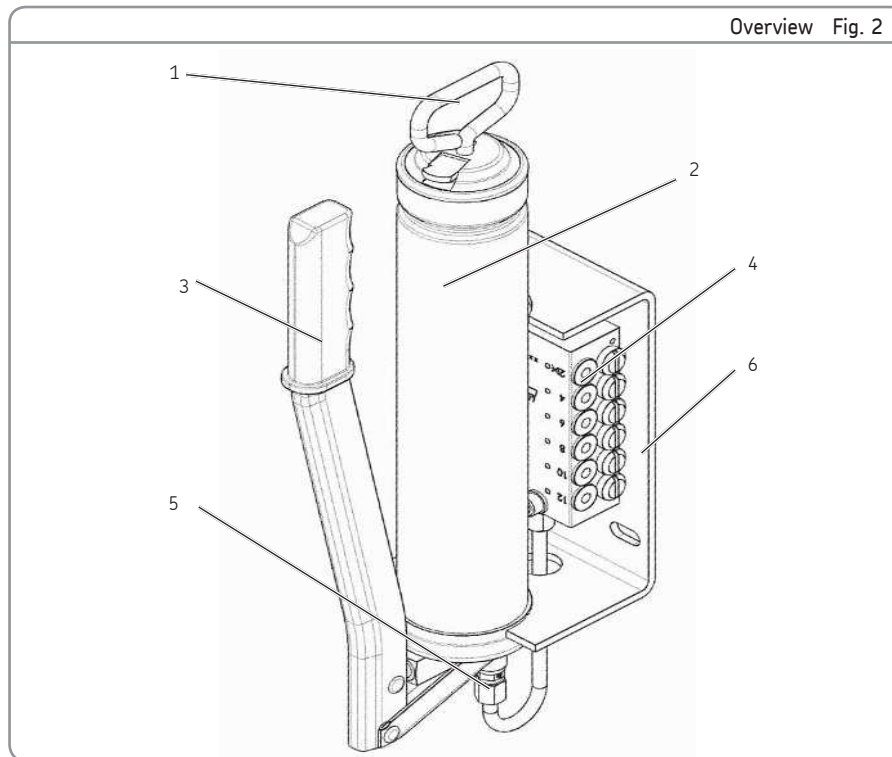

3.3 Typical configurations of a manual centralized lubrication system

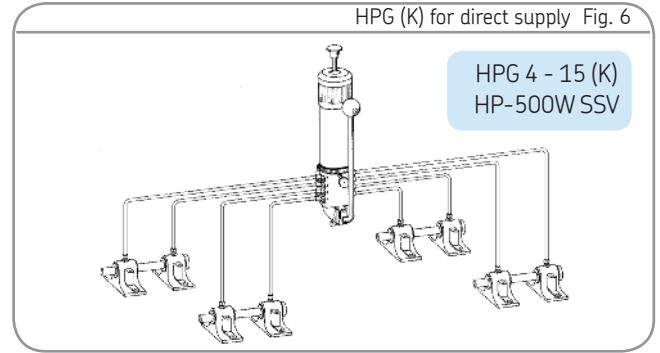
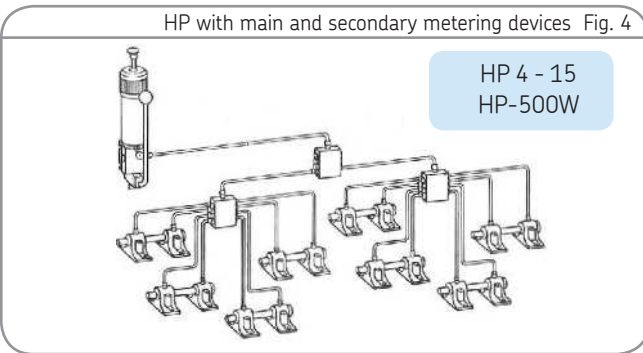
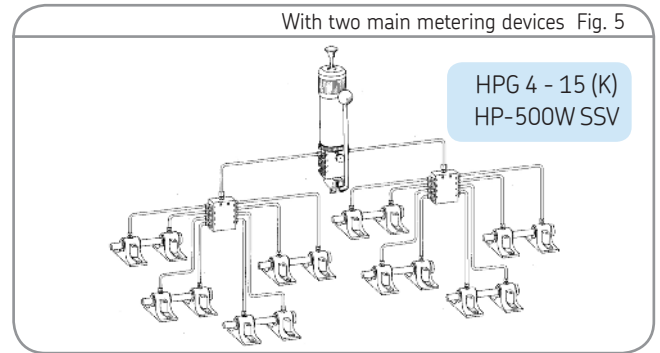
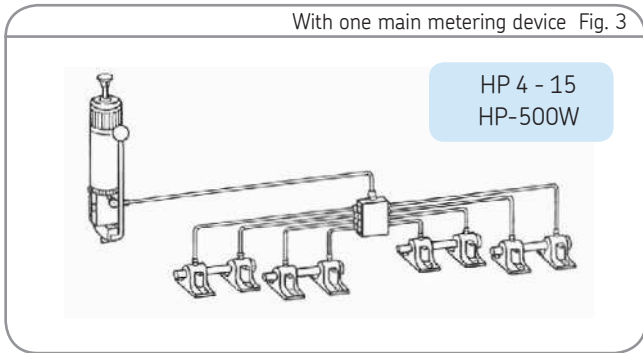

4. Technical data

Pump version	HP 4	HP 15	HPG 4	HPG 15 HPG 15 (K) ²	HP-500W	HP-500W SSV
Part numbers	See chapter 11					
Admissible operating temp.	-25 °C to 70 °C					
Operating pressure	max. 250 bar			max. 400 bar max. 350 bar		
Installation position	Vertical, i.e. reservoir on top					
Lubricants	Lubrication greases up to NLGI II					
Outlets	1	1	(2, 4, 6) ³ 8	2, 4, 6, 8	1	(6, 8, 10) ⁴ 12
Diameter supply lines	6 mm / 4 mm					
Output ¹	approx. 1.6 ccm / stroke			approx. 1.5 ccm / stroke		
Size of reservoir	0.4 l	1.5 l	0.4 l	1.5 l	0.4 l with cartridge 0.5 l without cartridge	
Weight (without lubricant)	3.3 kg	4.8 kg	3.5 kg	5 kg	1.9 kg	3.2 -3.8 kg ⁵

¹) Referring to greases NLGI grade 2 at + 20 °C and a counterpressure of 100 bar. Output per outlet approx. 0.2 ccm

²) K = Visual function display of metering device by means of indicator pin

³) by closing unneeded outlets with closure plugs (see chapter 7.2)

⁴) by closing unneeded outlets with closure plugs (see chapter 7.7)

⁵) depending on the dimension of the SSV metering device the weight increases in steps of 0.2 kg.

Information on HP-500W SSV

When using an SSV 6 metering device for each pump stroke a full metering device cycle is carried out, i.e. each outlet supplies once.

When using an SSV 12 metering device for one full metering device cycle there are required 2 pump strokes (SSV 12).

5. Delivery, returns and storage

5.1 Delivery

The products are packaged in accordance with standard commercial practice according to the regulations of the recipient's country. During transport, safe handling must be ensured.

After receipt of the shipment, the product(s) must be inspected for damage and for completeness according to the shipping documents. The packaging material must be preserved until any discrepancies are resolved.

5.2 Returns

Clean contaminated parts and pack them properly before returning them. Protect the product against mechanical influences such as impacts. There are no restrictions for land, air or sea transport. Mark returns on the packaging as follows:

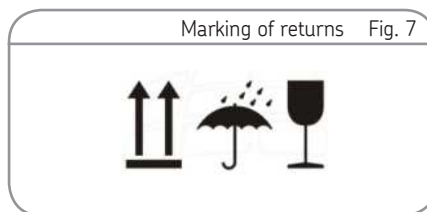

5.3 Storage

SKF products are subject to the following storage conditions:

Storage temperature
min. - 25 °C / max. + 70 °C

- Avoid direct sun or UV exposure
- Shield nearby sources of heat and coldness.

5.4 General notes related to storage

- The product(s) can be wrapped in plastic film to provide low-dust storage.
- Protection against ground moisture by storing on a shelf or wooden pallet.

6. Assembly

6.1 General information

Only qualified technical personnel may install, operate, maintain, and repair the progressive feeders described in the lifecycle manual. Qualified technical personnel are persons who have been trained, assigned, and instructed by the operator of the final product into which the progressive feeders are incorporated.

Such persons are familiar with the relevant standards, rules, accident prevention regulations, and operating conditions as a result of their training, experience, and instruction. They are qualified to carry out the required activities and in doing so recognize and avoid potential hazards.

Before assembling/ setting up the product, the packaging material and any shipping braces (e.g. plugs) must be removed.

The packaging material must be preserved until any discrepancies are resolved.

NOTE

Observe the technical data (chapter 4).

6.2 Set-up and attachment

The product should be protected against humidity and vibration and should be installed in an easily accessible position to ensure all other installations can be carried out without any problem. For indications on the maximum admissible ambient temperature see the technical data.

During assembly and during any drilling work, always pay attention to the following:

- Other units must not be damaged by assembly work.
- The product must not be installed within the range of moving parts.
- The product must be installed at an adequate distance from sources of heat and coldness.
- Maintain safety clearances and comply with local regulations for assembly and accident prevention.

6.3 Minimum assembly dimensions HP 4 - HPG 15 (K)

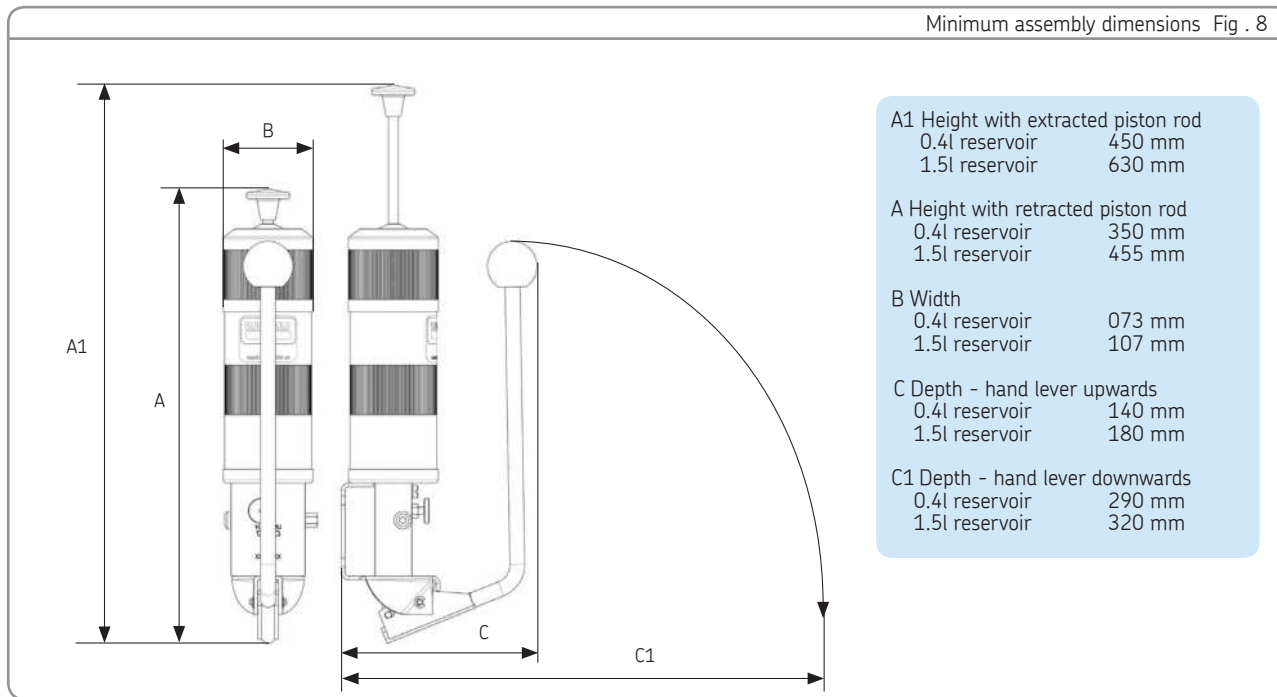

6.4 Connection dimensions HP 4 - HPG 15 (K)

The pump is fixed on four mounting bores (oblong holes) by means of M6 screws.

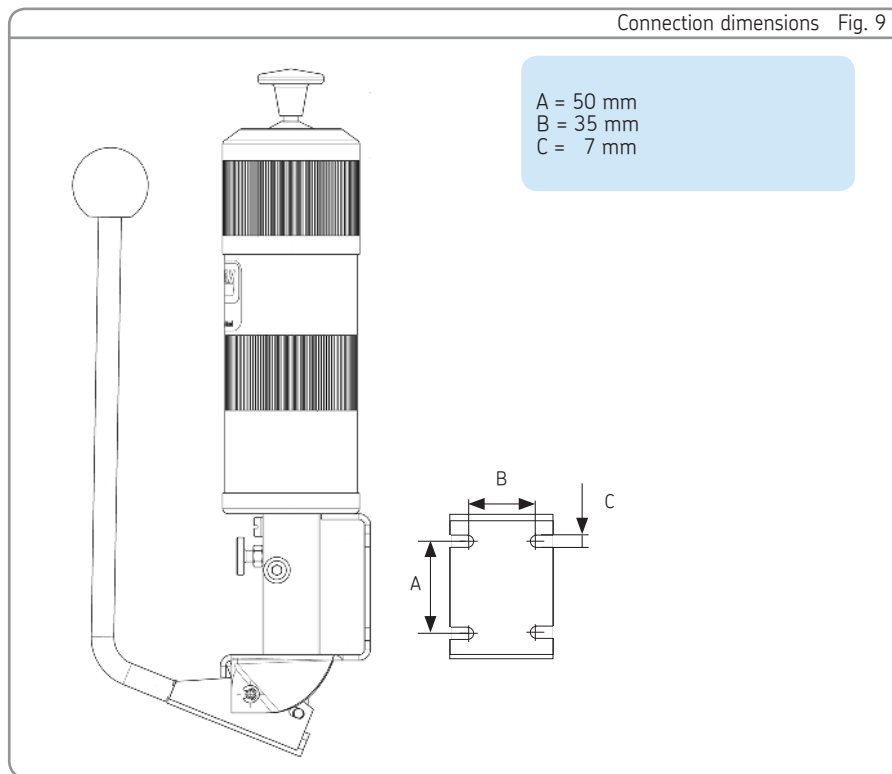

6.5 Minimum assembly dimensions HP-500W (SSV)

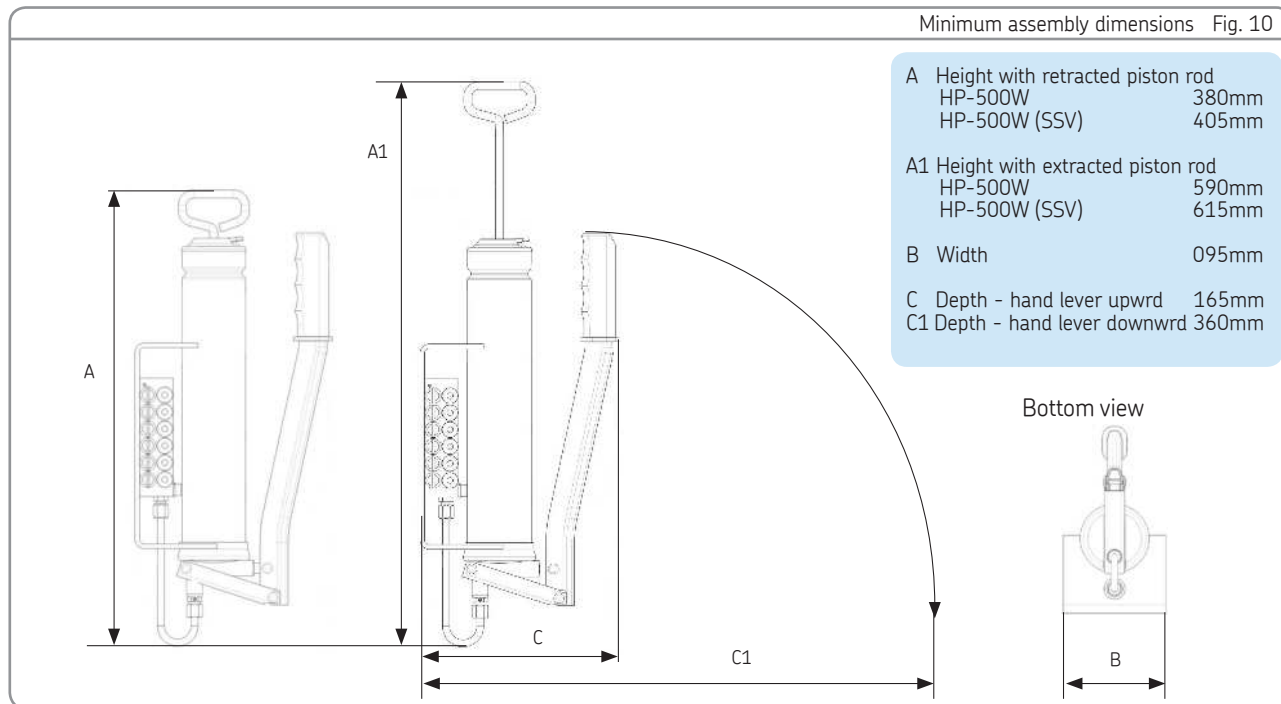

6.6 Connection dimensions HP-500W (SSV)

The pump is fixed on three mounting bores by means of M8 screws.

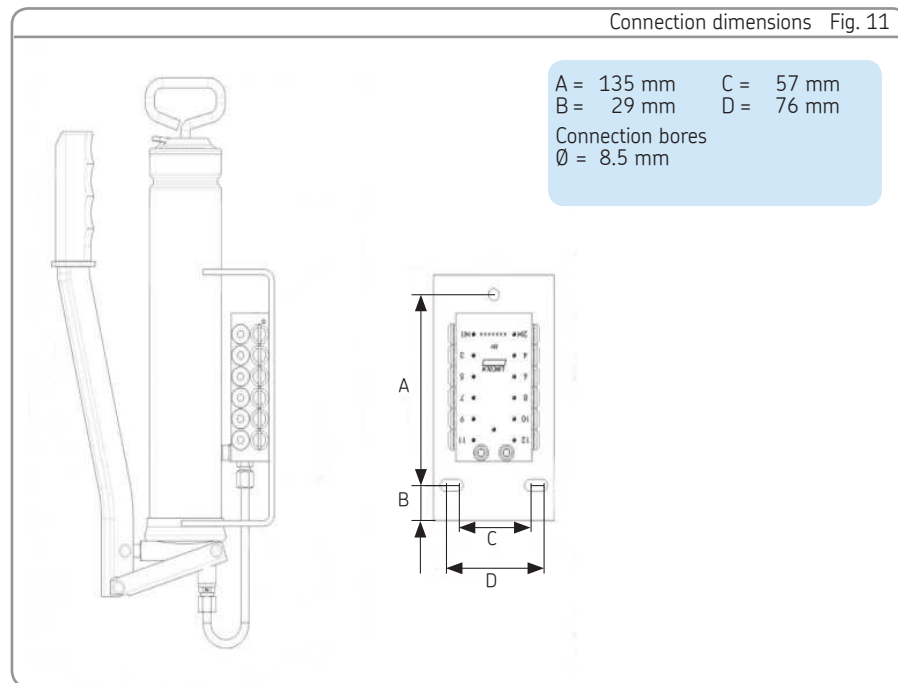

7. Start-up

HP 4, HP 15, HPG 4, HPG 15, HPG 15 K

7.1 Operating the pump

- Slowly pull the hand lever (3) downward until it stops. Thereby the pump will supply about 1.6 ccm of lubricant.
- When releasing the hand lever (3), it will automatically return into its initial position.

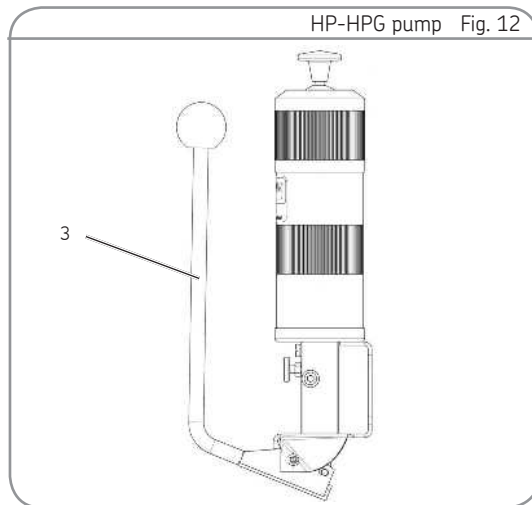

7.2 Modifying the output volume in case of the HPG pumps

About 0.2 ccm of lubricant are supplied per stroke and outlet. Closing of unneeded outlets with closure plugs (9) results in an increase of the output volume of the next open outlet below by the lubricant volume of the upper closed outlets on the same side.

NOTE

When closing the outlets 7/5 and 8/6 their output volume will not be supplied from the next outlet below, but will be returned to the reservoir.

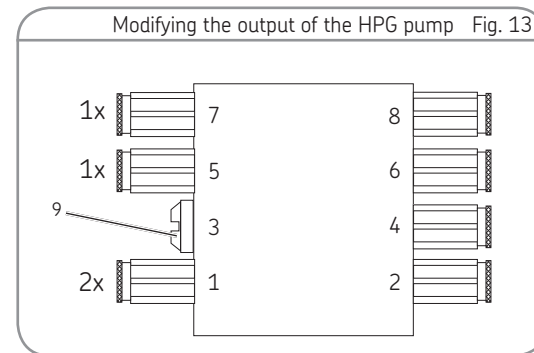

7.3 Filling via hydraulic lubrication fitting

Make sure that no air is sucked in while filling.

- Place grease pump on hydraulic lubrication fitting (7.1) and fill reservoir until the notch (12) on the piston rod can be engaged to the side of the reservoir.

NOTE

The HPG 4-HPG 15 (K) pump version has a marking ring. The reservoir is full as soon as the marking ring becomes visible.

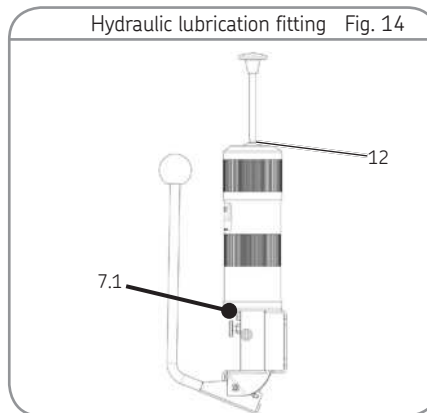

7.4 Filling via reservoir cover

- Pull piston rod upwards and engage it to the side.
- Unscrew the reservoir cover (10).
- Fill grease into reservoir up to upper rim and smooth it down with spatula.
- Screw on reservoir cover (10) again.
- If necessary, remove grease from reservoir outside.

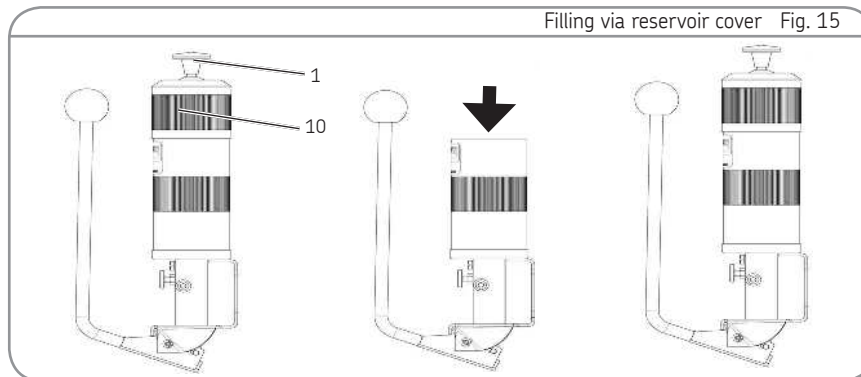

7.5 Venting

- Unscrew counternut (7.1) of the vent valve (7).
- Turn out vent valve (7) by maximum 1 revolution.

NOTE

Never unscrew vent valve completely, as otherwise the ball of the sealing seat may get lost.

- Loosen lines on metering device.
- Activate pump until lubricant penetrates free from bubbles.
- Tighten vent valve (7) and counternut (7.1) again.
- Mount lines filled with lubricant between the metering devices and the pump as well as between the metering devices and the lubrication points.

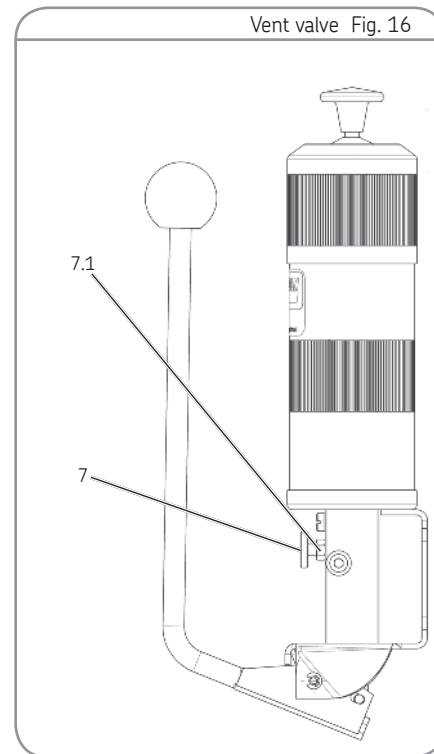
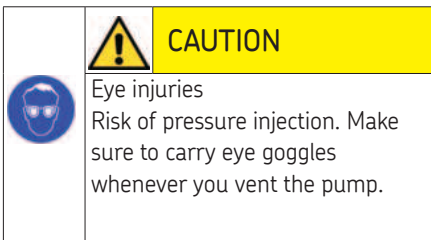

HP-500W, HP-500W SSV

7.6 Operating the pump

- Slowly pull down the hand lever (3) until it stops.
The pumps sucks in lubricant.
- Press hand lever (3) upwards into its initial position.
The pump dispenses lubricant into the lubrication line respectively in case of HPG-500W SSV pumps into the SSV metering device.
- After releasing the hand lever remains in its upper position.

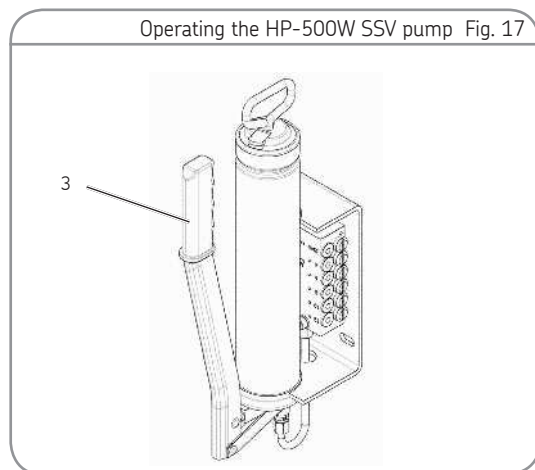

7.7 Modifying the output in case of HP-500W SSV pumps

Closing unneeded outlets by means of a closure screw (9) results in an increase of the output of the next open outlet below on the same side by the lubricant volume of the superior closed outlets.

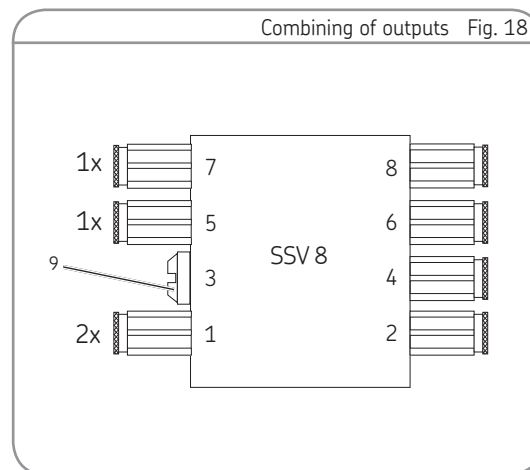

7.8 Inserting a standard cartridge (400g) in case of HP-500W (SSV) pumps

- Unscrew reservoir (2).
- Pull out piston rod (1) until it stops (will engage in the fixation).
- Remove both covers from the cartridge and press cartridge (11) into reservoir (large opening of cartridge must show towards the piston rod (1)).
- Screw reservoir onto pump by about 1 revolution.
- Loosen piston rod (1) and press it downwards until lubricant leaks from the thread of the reservoir (2).
- Screw reservoir back to pump completely.
- Remove leaked lubricant.

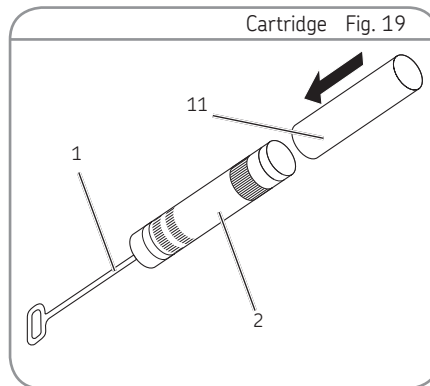

7.9 Filling HP-500W (SSV) pumps out of a grease container

NOTE

Don't turn the cup seal in the reservoir inside out.

- Unscrew reservoir from pump.
- Press reservoir into barrel only that much that the opening is below the grease level and no air is sucked in.
- Slowly pull piston rod upwards. Make sure that the opening of the reservoir still remains below the grease level.
- Screw reservoir onto pump by about 1 revolution.
- Press piston rod downwards until lubricant penetrates from reservoir free from bubbles.
- Screw reservoir back to pump completely.
- Remove leaked lubricant.

Filling from a grease container Fig. 20

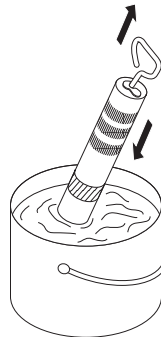

Venting Fig. 21

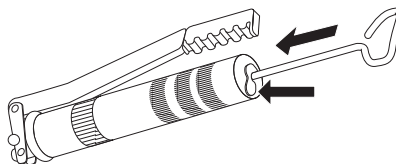

8. Operation, shutdown and disposal

8.1 General information

After the correct installation and filling with lubricant the pump is ready for operation.

8.2 Temporary shutdown

In case of a temporary shutdown remove the lubricant from the reservoir.

8.3 Shutdown and disposal

If the product will be permanently shut down, the local regulations and laws regarding the disposal of contaminated equipment must be observed. The product can also be returned to the manufacturer for disposal, in which case the customer is responsible for reimbursing the costs incurred. The parts are recyclable.

Disposal Fig. 22



9. Maintenance & Cleaning

9.1 General information

The manufacturer shall not be held liable for damages resulting from improperly performed assembly, maintenance or repair work on the product.

9.2 Cleaning

- Thoroughly clean all outside surfaces. Do not use aggressive cleaning agents. Interior cleaning is required only if contaminated lubricant was used.

9.3 Maintenance

- There are no parts to be maintained by the customer. Any defective parts have to be replaced by new ones.

10. Troubleshooting

10.1 HP 4 - HPG 15 (K)

Malfunction	Possible cause	Elimination
Pump does not supply	<ul style="list-style-type: none"> ○ Reservoir empty 	<ul style="list-style-type: none"> ○ Refill reservoir
Pump lever can be pressed down without any resistance	<ul style="list-style-type: none"> ○ Air inclusions in the pump ○ Ball of check valve or ball seat is contaminated or defective 	<ul style="list-style-type: none"> ○ Vent pump ○ Check, clean and, if applicable, replace parts concerned
Pump lever can be pressed down against large resistance only	<ul style="list-style-type: none"> ○ Blockade in the main line 	<ul style="list-style-type: none"> ○ Unscrew outlet fittings of the pump one after the other. Thus you will see in which main line the blockade is. Then loosen the outlet fittings on the metering device. This will show in which line there is a blockade. Then eliminate the blockade and correctly reinstall all lines.
Air leaks between reservoir bottom and pump	<ul style="list-style-type: none"> ○ Defective O-ring 	<ul style="list-style-type: none"> ○ Replace O-ring
Grease leaks between reservoir and reservoir bottom	<ul style="list-style-type: none"> ○ Defective seal 	<ul style="list-style-type: none"> ○ Replace seal
Grease leaks from pump body	<ul style="list-style-type: none"> ○ Defective O-ring 	<ul style="list-style-type: none"> ○ Replace O-ring

10.2 HP-500W (SSV)

Malfunction	Possible cause	Elimination
Pumpe does not dispense lubricant	<ul style="list-style-type: none"> ○ Empty reservoir ○ Empty cartridge ○ Suction hole clogged by foreign particle ○ Air inclusions in the grease 	<ul style="list-style-type: none"> ○ Refill reservoir ○ Replace cartridge ○ Remove reservoir and eliminate foreign particle ○ Loosen reservoir for about 2 cm. Strongly press down the piston rod until the air escapes from the thread of the reservoir and instead lubricant leaks.
Pump lever can be pressed upward only against high resistance	<ul style="list-style-type: none"> ○ Blockade in the main line / at the lubrication point ○ Blockade in the SSV metering device 	<ul style="list-style-type: none"> ○ Loosen outlet fittings on the SSV metering device one after the other. This shows in which main line there is a blockade. Eliminate blockade and correctly reinstall all lines.

11. Spare parts

11.1 HP 4-HPG 15 (K) pumps

Designation	Qty.	Part no.
HP 4 pump assy.	1	604-25102-1
HP 15 pump assy.	1	604-25103-1
HPG 4 pump assy.	1	604-25108-2
HPG 15 pump assy.	1	604-25109-2
HPG 15 (K) pump assy.	1	604-25128-2

11.2 HP-500W (SSV) pumps and SSV metering devices

Designation	Qty.	Part no.
HP-500W pump assy.	1	244-14164-1
HP-500W-SSV 6 pump assy.	1	604-28766-1
HP-500W-SSV 8 pump assy.	1	604-28767-1
HP-500W-SSV 10 pump assy.	1	604-28768-1
HP-500W-SSV 12 pump assy.	1	604-28769-1
SSV 6 metering device	1	619-26473-1
SSV 8 metering device	1	619-25730-2
SSV 10 metering device	1	619-26841-1
SSV 12 metering device	1	619-25731-2

11.3 Closure screws

Designation	Qty.	Part no.
Closure screw	1	303-17499-3
Copper sealing ring	1	209-12158-2

11.4 Outlet fittings

Designation	Qty.	Part no.
Lines Ø 6 mm		
Coupling nut	1	404-20236-4
Cutting ring/ sealing ring	1	404-23034-1
Lines Ø 6 mm with check valve		
Coupling nut	1	223-12374-9
Cutting ring	1	223-12295-2
Valve body	1	504-30364-4
Cutting ring/ sealing ring	1	404-23034-1
Lines Ø 4 mm with check valve		
Coupling nut	1	223-13032-1
Cutting ring	1	223-12295-2
Valve body	1	504-30517-2
Cutting/sealing ring	1	404-23034-1

11.5 Connection tube for HP-500W SSV pumps

Designation	Qty.	Part no.
Connection tube for SSV metering device 1		438-24497-1

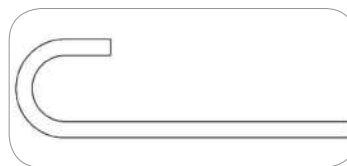

11.6 Reservoir assemblies for HP and HPG pumps

Designation	Qty.	Part no.
Reservoir assy. 0.4 l	1	504-30316-1
Reservoir assy. 1.5 l	1	504-30317-1

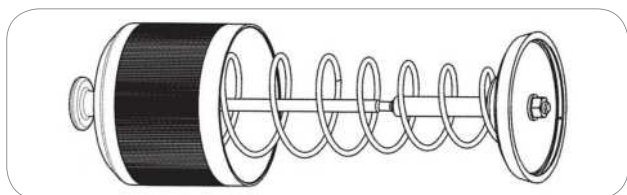

11.7 Hand lever and ball head for HP and HPG pumps

Designation	Qty.	Part no.
Hand lever	1	504-30791-1
Ball head	1	221-12496-1



11.8 Bracket with bottom for HP and HPG pumps

Designation	Qty.	Part no.
Bracket with bottom for 0.4 l reservoir	1	504-30324-1
Bracket with bottom for 1.5 l reservoir	1	504-30355-5

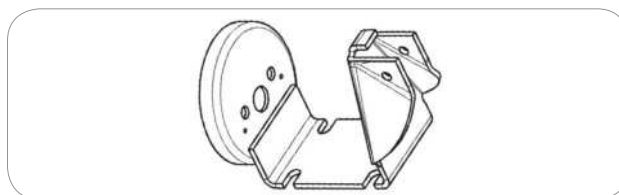

11.9 Pump bodies for HPG pumps

Designation	Qty.	Part no.
Pump body assy.	1	504-30355-5

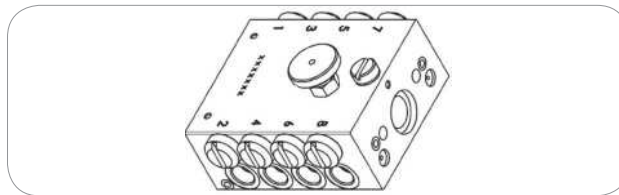

Notes

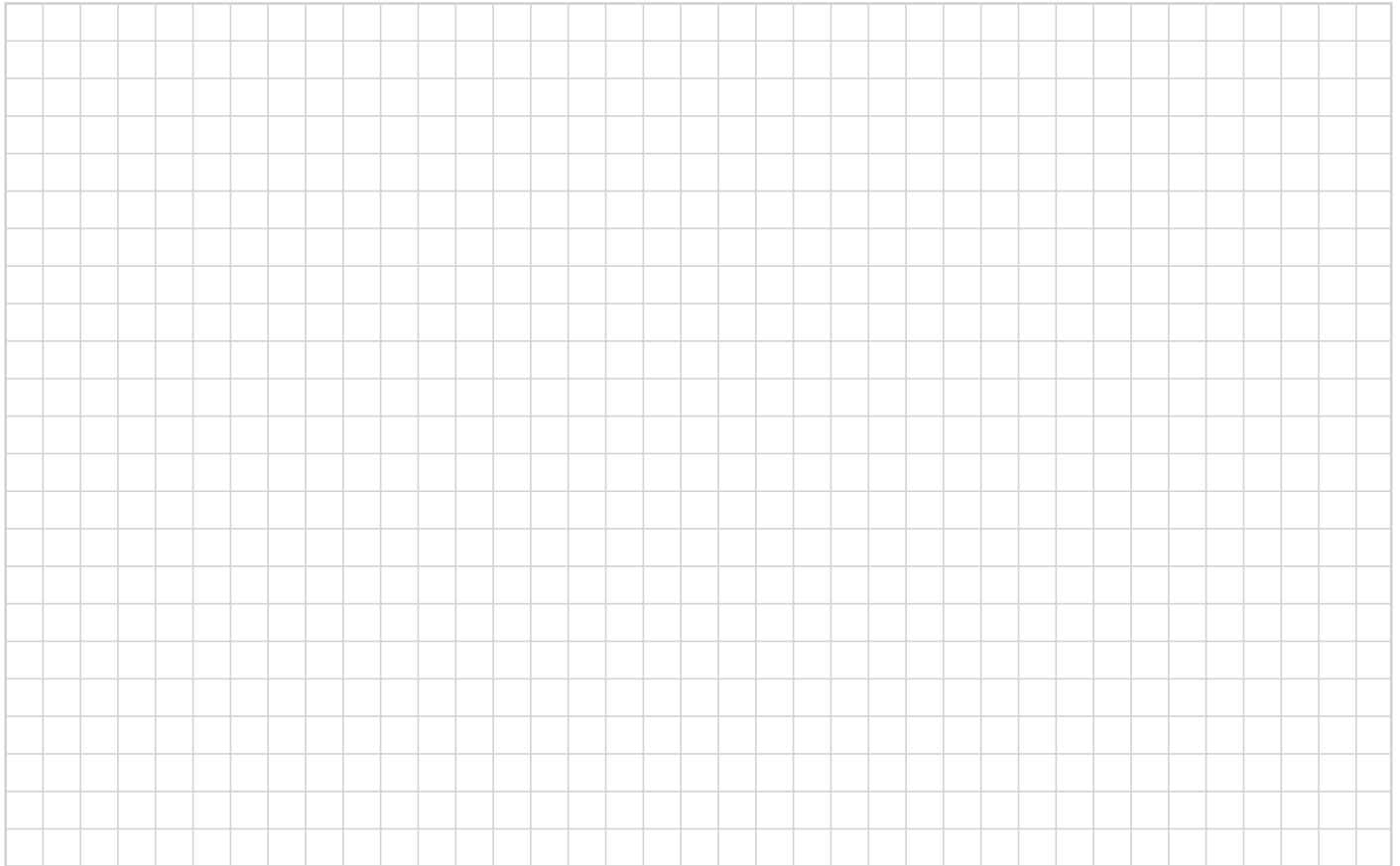

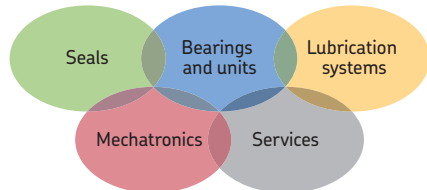

The Power of Knowledge Engineering

Drawing on five areas of competence and application-specific expertise amassed over more than 100 years, SKF brings innovative solutions to OEMs and production facilities in every major industry worldwide. These five competence areas include bearings and units, seals, lubrication systems, mechatronics (combining mechanics and electronics into intelligent systems), and a wide range of services, from 3-D computer modelling to advanced condition monitoring and reliability and asset management systems. A global presence provides SKF customers uniform quality standards and worldwide product availability.

951-231-000-EN
July 2014
Version 02

SKF Lubrication Systems Germany GmbH
Walldorf plant
Heinrich-Hertz-Str. 2-8
DE - 69190 Walldorf
Tel: +49 (0) 6227 33-0
Fax: +49 (0) 6227 33-259
E-mail: Lubrication-germany@skf.com
www.skf.com/lubrication

Important information on product usage

All products from SKF may be used only for their intended purpose as described in this brochure and in any instructions. If operating instructions are supplied with the products, they must be read and followed.

Not all lubricants are suitable for use in centralized lubrication systems. SKF does offer an inspection service to test customer supplied lubricant to determine if it can be used in a centralized system. SKF lubrication systems or their components are not approved for use with gases, liquefied gases, pressurized gases in solution and fluids with a vapor pressure exceeding normal atmospheric pressure (1 013 mbar) by more than 0,5 bar at their maximum permissible temperature.

Hazardous materials of any kind, especially the materials classified as hazardous by European Community Directive EC 67/548/EEC, Article 2, Par. 2, may only be used to fill SKF centralized lubrication systems and components and delivered and/or distributed with the same after consulting with and receiving written approval from SKF.

