

# ISO 199:2014 and ISO 492:2014 standards – complexity versus unambiguity

ISO 199 [1] and ISO 492 [2] standards have been reviewed in order to improve the representation of the tolerance characteristics. State of the art tolerancing according to ISO geometrical product specifications (GPS) has been applied.

**IN THE FORMER VERSIONS** of ISO 199 and ISO 492 standards, the functional requirements were expressed by verbal descriptions according to ISO 1132-1 standard [3]. It was not easy to understand this; for example, 10 definitions were needed to describe a bore diameter tolerance. Even rolling bearing specialists were not always sure how to understand these definitions. Moreover, for non-rolling bearing people it was an unusual way to become informed about the specifications. In the automotive and machine industries, the

indication of ISO geometrical product specifications (GPS) by means of symbols is state of the art, and verbal descriptions have been avoided for decades.

Therefore, the ISO/TC 4 (ISO Technical Committee for rolling bearings) decided in 2009 to also express rolling bearing tolerance characteristics with ISO GPS symbols.

At the time, ISO/TC 4 experts could not imagine that future ISO 199 and ISO 492 standards would include complex specifications, especially on dimensional

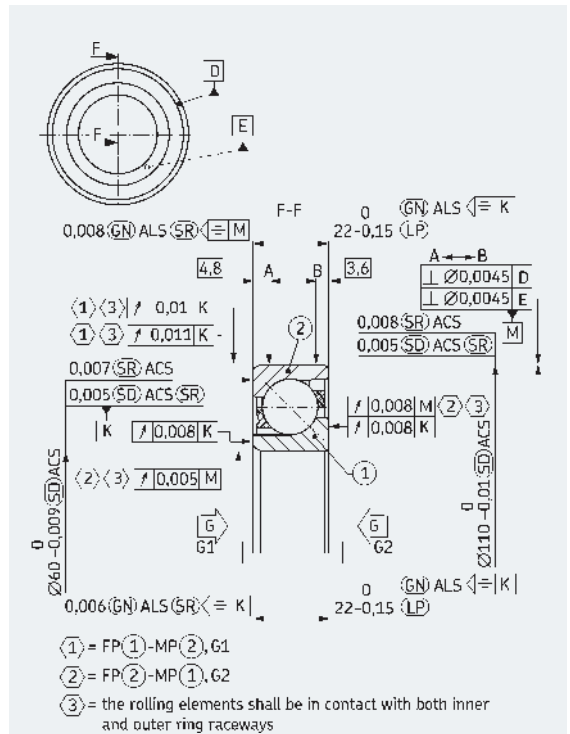
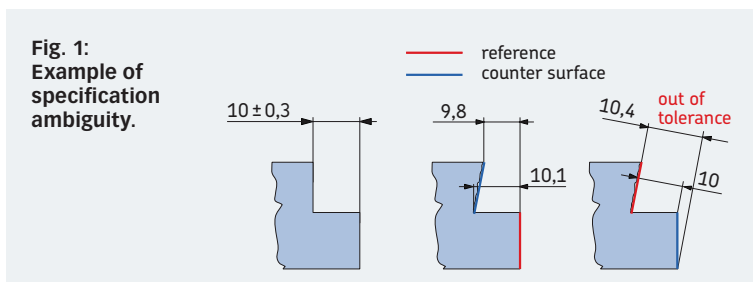

**Fig. 2: Single row angular contact ball bearing 7212, tolerance class 5 – tolerance indications according to ISO 492:2014.**

tolerancing, because no ISO GPS standard for dimensional tolerancing was available, except ISO 286-1 [4] and ISO 286-2 [5] standards. It was usual to apply  $\pm$  tolerances on all dimensions, even when it was obvious that this could result in specification ambiguities, meaning that the user of the specification (e.g., at measurements) could apply the specification in different ways (fig. 1).

To improve this situation, the ISO 14405-1 standard [6] was published in 2010. This ISO GPS standard includes several possibilities for dimensional tolerancing. It was immediately applied in draft versions of the new ISO 199 and ISO 492 standards, and the proper characteristics could be found to fulfil the functional requirements of rolling bearings.

## The complexity

ISO 199:2014 and ISO 492:2014 standards now include ISO GPS



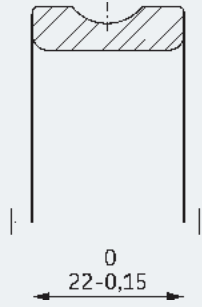

Fig. 3: Deep groove ball bearing inner ring width specification with default specification operator.

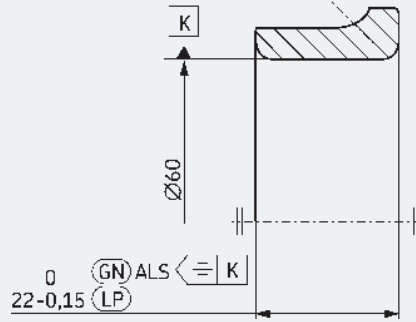

Fig. 4: Angular contact ball bearing inner ring width specification.

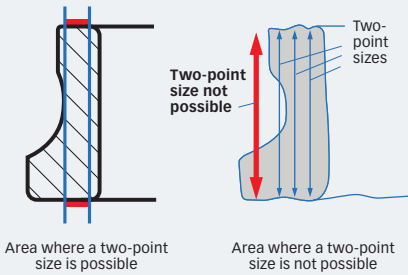

Fig. 5: Two-point size on an asymmetrical ring.

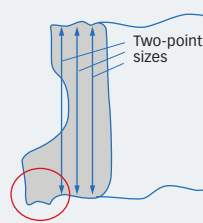

Fig. 6: Form deviation out of the area of two-point sizes.

symbols. But when all the relevant characteristics are indicated in one view, such as on a single row angular contact ball bearing, a rather complex drawing results (fig 2).

The complexity has to be seen on two levels:

- Level 1 is simply based on the number of GPS characteristics. This kind of complexity can easily be limited by reading the indications in portions.
- Level 2 is based on the need to make the tolerance specification unambiguous and to transform the functional requirements on the part into GPS specifications.

In some cases the full specification is not visible on a drawing, because default specifications as given in ISO GPS standards are relevant.

Example:

On dimensioning of features of size (e.g., a cylinder), two-point size according to ISO 14405-1 is the default specification operator. Therefore the specification modifier  $\text{LP}$  for two-point size shall not be indicated when applied for both upper and lower deviation limits. This is relevant, for example, on ring width specification on a deep groove ball bearing with symmetrical rings (fig. 3).

Note:

If the two-point size is applied for only one of the two specified deviation limits, the  $\text{LP}$  specification modifier shall be indicated after the relevant deviation limit (fig. 4).

However, in case of default specification operators it is necessary to consider all details as given in

the relevant ISO GPS standards. This can result in a comprehensive amount of information. See *Evolution #3 2012* [7] about tolerances for a rolling bearing bore diameter.

Looking again at fig. 2 and particularly at details on dimensional tolerances, specification modifiers next to the tolerance values can always be observed.

On the example of the inner ring width specification (fig. 4) it will be demonstrated that complex indications are necessary to avoid ambiguities originating from:

- the basic ring geometry;
- geometrical deviations occurring during manufacturing;
- undefined orientation of ALS (any longitudinal section);
- local deviations on the ring faces.

### The basic ring geometry

Single row angular contact ball bearing rings are asymmetrical. This implies that a two-point size as applied on symmetrical rings such as on a deep groove ball bearing (fig. 3) is not appropriate, because only areas of the ring where opposite material is available can be covered by two-point size (fig. 5).

The ambiguity:

If a two-point size is specified, the part of the large inner ring face next to the shoulder would not be considered, and if form deviations occur in the direction out of the material, the functional width of the ring according to the mounting situation would not be detected (fig. 6).

The solution:

Application of  $\text{GN}$ , minimum circumscribed size according to the ISO 14405-1 standard.  $\text{GN}$  is a global size, i.e., it considers the full extent of both small and large inner ring face (fig. 7).

### Geometrical deviations occurring during manufacturing

Rings have the tendency to be deformed (bent) after heat treatment. This form deviation still exists after further manufacturing steps such as grinding, because when a ring is flat when fixed at the machine tool, after unclamping the ring is again bent. This phenomenon can only be compensated by extensive additional heat treatment between the grinding operations and/or additional grinding steps.

However, rings are flexible and will be flat when mounted and axially fixed on the shaft.

The ambiguity:

If  $\text{GN}$  would be applied on the total ring, the result of a measurement would not reflect the real situation when mounted (fig. 8).

The solution:

$\text{GN}$  is applied in ALS (any longitudinal section) according to the ISO 14405-1 standard and is consequently only relevant on intersection lines constructed by the ALS plane and the real ring faces and no longer on the whole ring faces (fig. 9).

### Undefined orientation of ALS

The ambiguity:

ALS could be oriented in different ways, e.g., including the axis of the bore, including the axis of the shoulder diameter or perpendicular to the large ring face.

The solution:

ALS is oriented to include the axis of the bore, because it is generally used as a datum to control other GPS characteristics of the inner ring.

On the drawing the specification modifier  $\text{ALS}$  has to be added next to ALS (fig. 4). This modifier means the intersection plane. For the time being this is only included in the ISO 1101 standard [8] for geometrical tolerancing, but the ISO 14405-1 standard is in review and will include intersection planes as well. The symmetry symbol in the first compartment of the symbol indicates that the intersection plane has to include a datum as determined in the second compartment. Based on the latter, the bore axis has to be defined as the datum (figs. 4 and 10).

Consequently, the two parallel lines defining the minimum circumscribed size are oriented symmetrically to the bore axis.

### Local deviations on the ring face

The ambiguity:

$\text{GN ALS}$  cannot consider local deviations in the direction inside the material (fig. 11).

Such deviations can lead to an inappropriate fit on the interface

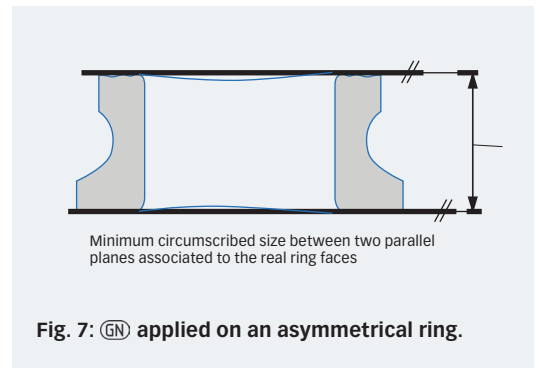

Fig. 7:  $\text{GN}$  applied on an asymmetrical ring.

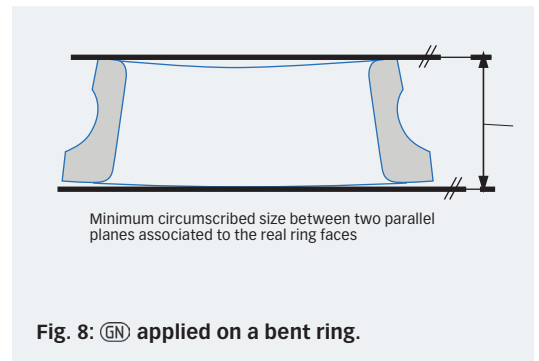

Fig. 8:  $\text{GN}$  applied on a bent ring.

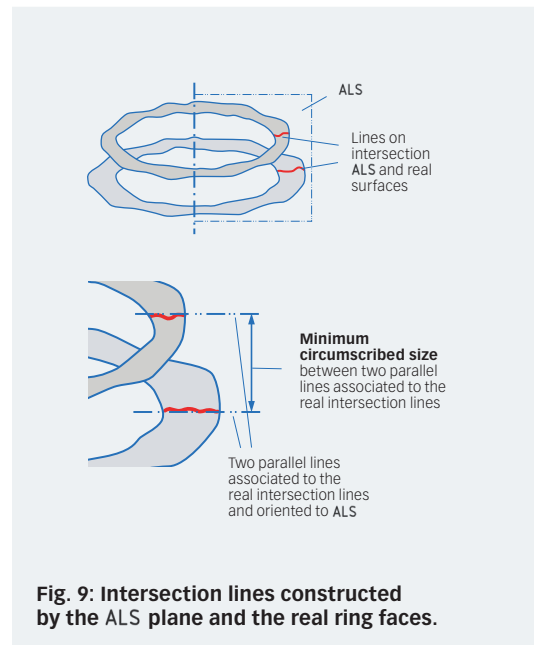

Fig. 9: Intersection lines constructed by the ALS plane and the real ring faces.

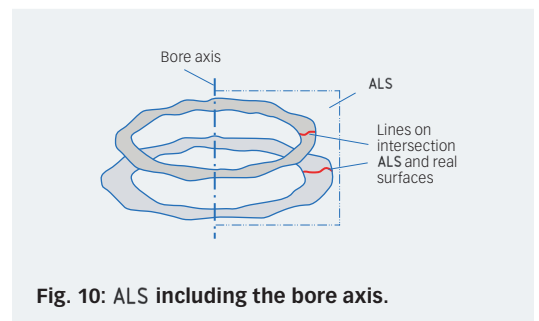

Fig. 10: ALS including the bore axis.

ring face and shaft shoulder face and could result, for example, in fretting corrosion.

The solution:

$\textcircled{\text{GN}}\text{ALS} \left\langle \begin{array}{|c|} \hline \text{K} \\ \hline \end{array} \right\rangle$  is applied on the upper tolerance limit only. For the lower tolerance limit the two-point size is specified.

In this case the modifier  $\textcircled{\text{LP}}$  needs to be indicated, because it is applied on the lower tolerance limit only.

### Final size specification

$0 \textcircled{\text{GN}}\text{ALS} \left\langle \begin{array}{|c|} \hline \text{K} \\ \hline \end{array} \right\rangle$   
 $22 -0,15 \textcircled{\text{LP}}$

Descriptions according to ISO 492:2014:

$\textcircled{\text{GN}}\text{ALS} \left\langle \begin{array}{|c|} \hline \text{K} \\ \hline \end{array} \right\rangle$

deviation of a minimum circumscribed size of inner ring width between two opposite lines, in any longitudinal section that includes the inner ring bore axis, from its nominal size;

$\textcircled{\text{LP}}$

deviation of a two-point size of inner ring width from its nominal size.

It may be paradoxical, but  $\textcircled{\text{GN}}\text{ALS} \left\langle \begin{array}{|c|} \hline \text{K} \\ \hline \end{array} \right\rangle$  can also be described in a simple way; it can be imagined as a calliper. On a calliper there are two parallel lines. These have to be moved to the ring faces and oriented in an ALS in order to get the minimum circumscribed size (fig. 12).

Now, somebody could ask, Why is a complex specification needed?

An appropriate answer: Measure with a calliper; the right operations are done intuitively based on the skills and the sensitivity of the person doing the measurement. On other measuring equipment, e.g., coordinate measuring systems, nothing can be done intuitively, and all the details involved in how to set up the measurement have to be based on a complete and unambiguous specification.

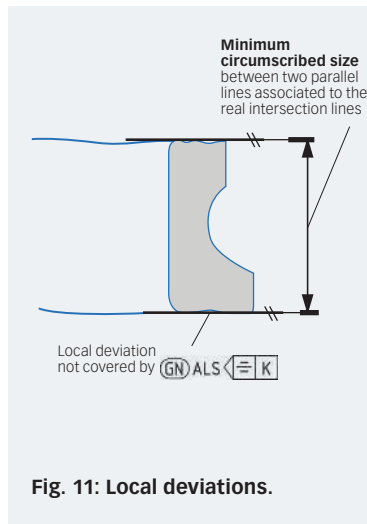

Fig. 11: Local deviations.

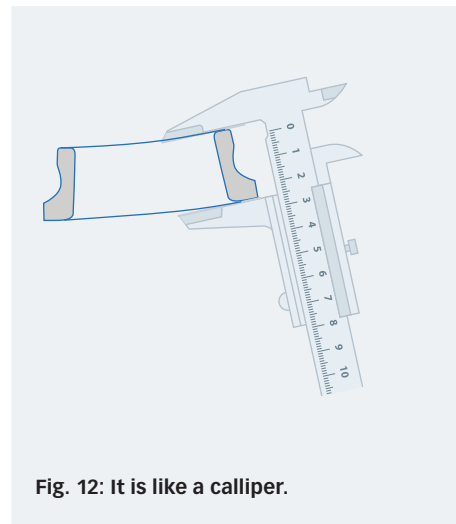

Fig. 12: It is like a calliper.

Width deviation on asymmetric rings is only one example out of all ISO 199:2014 and ISO 492:2014 standards characteristics.

Another special case is run-out specification on assembled bearings where specification modifiers according to ISO/TS 17863 [9] are indicated in order to assure that the components of a rolling bearing (which is a movable assembly) are kept together. Otherwise ambiguities due to, for example, radial or axial clearance would occur.

This and all other specifications need to be explained as well.

For this purpose SKF offers an e-learning module on all ISO 199:2014 and ISO 492:2014 characteristics at [skf.com](http://skf.com). ●

#### Author:

**Hans Wiesner**, Geometrical Product Specification (GPS) Expert, SKF Group Technology Development – Standards & Practices, Austria

#### References

- [1] ISO 199 Rolling bearings – Thrust bearings – Geometrical product specification (GPS) and tolerance values
- [2] ISO 492 Rolling bearings – Radial bearings – Geometrical product specifications (GPS) and tolerance values
- [3] ISO 1132-1 Rolling bearings – Tolerances – Part 1: Terms and definitions
- [4] ISO 286-1 Geometrical product specifications (GPS) – ISO code system for tolerances on linear sizes – Part 1: Basis of tolerances, deviations and fits
- [5] ISO 286-2 Geometrical product specifications (GPS) – ISO code system for tolerances on linear sizes – Part 2: Tables of standard tolerance classes and limit deviations for holes and shafts
- [6] ISO 14405-1 Geometrical product specifications (GPS) – Dimensional tolerancing – Part 1: Linear sizes
- [7] SKF Evolution #3 2012 – Technology – Rolling bearings TC 4 meets GPS TC 213
- [8] ISO 1101 Geometrical Product Specifications (GPS) – Geometrical tolerancing – Tolerances of form, orientation, location and run-out
- [9] ISO/TS 17863 Geometrical product specification (GPS) – Geometrical tolerancing of movable assemblies

#### Summary

Complex indications always have a reasonable background, but it is necessary to explain the background and the drawing indication. Doing this, the disadvantage of indications that are too complex can be turned into the advantage of complete specifications in which ambiguities are reduced to a minimum.