

SKF Pulp and Paper Practices

A compilation of issues 1-15 of the SKF technical newsletter for the Pulp and Paper industry



Pulp & Paper Practice issue

- 1** Welcome to the first edition of “SKF Pulp & Paper Practices”
 - Feeler gauge method for mounting bearings with tapered bores..... 2
 - The case of the failed shaker screen bearing..... 8
- 2** Back in time
 - C4 instead of C32
 - The case of the split inner race..... 8
- 3** The importance of proper mounting and stores management
 - SKF Drive-up method and SensorMount 2
- 4** SKF self-aligning bearings and the pulp & paper industry
 - New heat treatment for improved performance2
 - Store rooms often reflect maintenance practice 7
- 5** As good as new?
 - Bearing remanufacturing 2
- 6** We all have a lot in common whether we see it or not
 - Drying & Yankee cylinder bearings & their lubrication (Part 1) 2
- 7** I do not want to be called an “expert”
 - Drying & Yankee cylinder bearings & their lubrication (Part 2) 2
- 8** Contamination, corrosion and inadequate lubrication
 - Sealed spherical roller bearings..... 2
- 9** Simple components?
 - Calculated rating life vs. service life2
 - The information needed for a bearing study5
 - Information needed for a root cause failure analysis..... 8
- 10** Idled machines still need maintenance
 - Restarting production after a long stop can be costly if you don't do it right 2
 - Small things can matter..... 6
- 11** The power of knowledge and getting your hands dirty
 - Just some tips..... 2
- 12** Don't judge too quickly
 - Paper machine speed increases 2
- 13** We don't talk about microns in a mill workshop
 - Checking tapered journal geometry 2
- 14** Don't get rid of your archives!
 - Checking tapered journal geometry (continued)..... 2
- 15** Digital vs. paper information
 - Fulfilling promises and responding to questions.....2



Welcome to the first edition of “SKF Pulp & Paper Practices”

The challenge today is that the pulp and paper industry, globally, has become extremely competitive. Companies everywhere are trying to get the most from their machines. Whether mills are using state-of-the-art machines or older ones that have been in operation for decades, all are facing the challenge of developing new people or retaining the knowledge of those that are retiring. As a result, the knowledge of best practices related to maximizing bearing service life is not available in some regions and is being lost in others.

So, what can SKF do to help? We can provide our customers with our knowledge on how to increase service life by using the right techniques and tools. Our intention with this regular newsletter is to do just that.

Let's start with some techniques from the experts. Techniques developed, over time, to establish best practices. In this issue, we will cover using the feeler gauge method to achieve appropriate clear-

ance in bearings. In the next issue we will look at the basics of why you need clearance in bearings. Everyone knows what results they want, but it is sometimes good to refresh our memory of how to achieve it and why it is so important.

Scott Morris
Global Segment Manager
Pulp & Paper, SKF
scott.morris@skf.com



Feeler gauge method for mounting bearings with tapered bores

In this first issue of SKF Pulp & Paper Practices, I want to cover the feeler gauge method for mounting bearings with tapered bores. The reason being, despite being the best known and most widely used approach, I have seen a lot of misunderstanding about it and bad practices when using it.

Before looking at the feeler gauge method in detail, let's discuss on interference fits and other mounting methods.

Interference fits

Bearings with tapered bores are always mounted with an interference fit (i.e. a tight fit) on their seat. The correct interference fit is obtained by driving the bearing axially up its tapered seat.

The first question is what is the correct interference fit? Well, an insufficient interference fit will lead to fretting corrosion (→ **fig. 1**) which is due to micro displacement between two surfaces and/or creeping which is due to ring deformation under high load. With time, the inner ring works loose and can rotate on its seat leading to heavy wear and smearing. In general, we can say that the higher the load on the bearing, the tighter the fit that will be needed.

However, too high an interference fit will create high stresses in the inner ring which, when combined with the stress due to load, can reduce fatigue life. It may also cause ring fracture with some steel qualities and certain heat treatment methods especially if there is raceway surface damage.

Fig. 1. Inner ring of a spherical roller bearing showing fretting corrosion in the bore because of an insufficiently tight fit.



Philippe Gachet is an SKF application engineer who has been working with heavy industries, particularly pulp and paper, since 1990. He can be contacted at philippe.gachet@skf.com



So, what is the correct interference fit? Well, it depends. I know some people hate this sort of answer, but it is true. It depends on the application and on the operating conditions. Shaft material, load, speed, the lubrication regime and the temperature are all important. As are many other things.

SKF, in our General Catalogue, gives generic recommendations for obtaining a correct interference fit on solid steel shafts. This may seem vague, but the recommendations are based on years of experience in the field even if they don't always give the optimum fit.

Certain applications in pulp or paper mills need more precise recommendations. Examples include modern press roll bearings and felt rolls where tension has been increased due to increased speed or the conversion to a felt-driven drive system. These exceptions explain why there can be differences between SKF general recommendations and those given by one of our engineers for a specific application.

Fig. 2. The first CARB mounted in France. This was at International Paper Saillat using the SKF Drive-up Method. The author is shown on the left.



For those who want more information on how to choose the correct interference fit for an application, I will explain further in the next issue of this newsletter.

Different mounting methods

Once the correct interference fit is known there are several ways of achieving it:

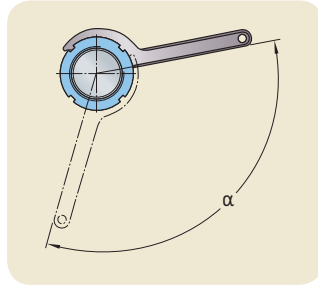

Fig. 3. Locknut tightening angle method.

- 1 Measuring axial drive-up. The difficulty is to find the starting position when the inner ring, after smoothing the asperities and getting in intimate contact with its inner ring, begins to expand radially. This is why measuring axial drive-up is quite imprecise unless the quick and precise SKF Drive-up Method it used (→ fig. 2).
- 2 Measuring locknut tightening angle (→ fig. 3). If you know the nut thread and the tightening angle, you know the axial displacement. Here, again, the lack of precision is due to the difficulty to find the starting position. It's one of the most popular methods when mounting self-aligning ball bearings. Most of the time these bearings are mounted with a higher interference fit than is needed.
- 3 Measuring inner ring expansion (→ fig. 4). This is a quite common method for cylindrical roller bearings in machine tool spindles, but I never saw it used in the pulp and paper industry until SKF launched the SKF SensorMount method for large size bearings e.g. press roll bearings. This method uses a sensor integrated in the inner ring. It's very accurate and fast.

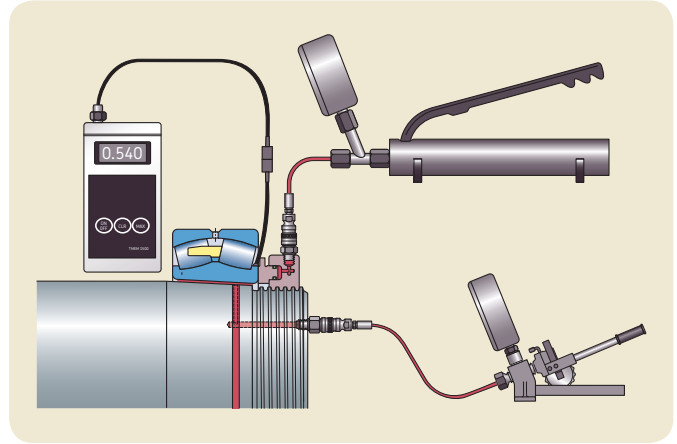

Fig. 4. SKF SensorMount method.

- 4 Measuring the exact dimensions and position of the bearing taper seat and creating a spacer against which the bearing is pushed into place (→ fig. 5). This is only valid for 240 and 241 series spherical roller bearings and for some high-precision printing machinery spherical roller bearings that are sometimes used in tissue converting equipment. This method needs special training, especially when using the 9205 SKF gauge. However, once the

Fig. 5. SKF 9205 gauge.

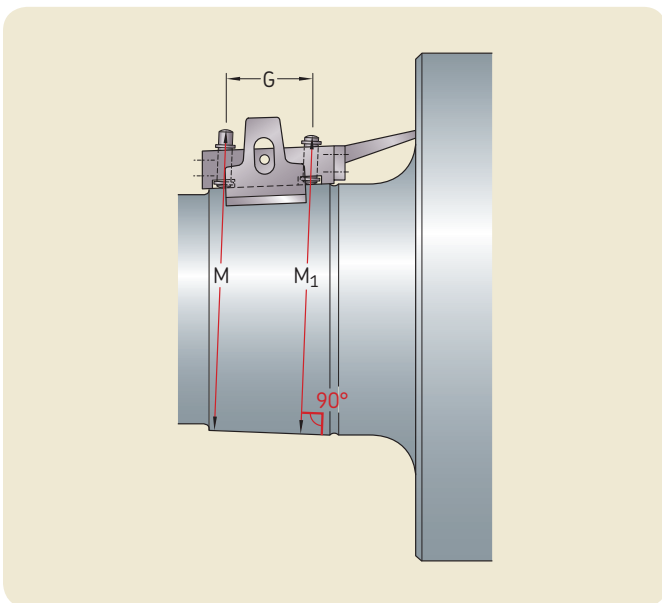

Fig. 6.



spacer is created, and if the bearing seat is in a good condition, the replacement bearing is simply pushed against the spacer and the correct interference fit is achieved.

- 5 Measuring clearance reduction with the help of feeler gauges. This method is explained later on and you will see that it isn't accurate and fast.

In a future issue of SKF Pulp & Paper Practices, I will come back to the SKF Drive-up Method, SKF SensorMount and the 9205 gauge method.

Before mounting the bearing, check the shaft geometry. Without going into details on this subject, I would recommend using the Prussian Blue method. It's quick and, in most cases, is enough when you do not have the correct tools and information. The surface in contact should be at least 80% (90% for new bearing seat). For heavy bearings needing a bridge crane, add a spring between the bearing and the hook (→ fig. 6).

The feeler gauge method

When driving up a bearing on its taper seat, the inner ring expands radially. As the inner ring expands, the clearance in the bearing decreases. There is a direct relation between the drive-up and the clearance reduction.

The feeler gauge method measures the internal clearance reduction by passing the gauge between the rollers and the raceway. With this method, you do not adjust the internal clearance as some believe. You adjust the correct ring expansion to have the correct tight fit.

Using a feeler gauge isn't accurate. It depends on experience and feeling. Each person is different. Some consider that they have the correct clearance when the feeler gauge is slightly loose, others when it is slightly tight but still moves and some when it feels like trying to move the feeler in grease. This explains how two experienced fitters can get different values for the same measurement.

We all measure with a certain degree of error.. Trying to get the exact value of a clearance with a feeler gauge is a waste of time. However, as a specific fitter has the same feeling, and thus the same error, the clearance reduction value (i.e the difference between two clearances with the same error), will be quite close to reality.

Rule number 1: The bearing internal clearance and clearance reduction during mounting must be done by the same person.

In addition to the poor accuracy based on the "feeling", I have to add that the clearance between a roller and the raceway can change depending on roller position in the bearing and on the ring's position in relation to each other. For example, if somebody passes next to the bearing during the mounting procedure and accidentally moves the outer ring, the measured clearance before and after this "accident" can change and make the clearance reduction inaccurate.

Introducing a feeler gauge in the bearing can make a roller move. Very small movements have small effects. The best thing is to hold the roller with your fingers, or by a slight pressure with one finger against the roller end face, and avoid using a thick feeler gauge at the beginning.

Rule number 2: During clearance reduction measurement, the bearing elements (rollers and rings) must not move in relation to one another.



Fig. 7. Rotating the outer ring with a clean screwdriver.

Bearing rings can easily deform, especially rings from the large thin section bearing series such as the 238 and 239 series (used on some deflection controlled press rolls and some suction rolls bearings) or 248 and 249 series (less common in the paper industry). For a 239/500 (500 mm bore bearing), it has been shown that it is possible to force a gauge that is approximately 0,1 mm too thick between the roller and the outer ring.

Rule number 3: Start taking the clearance measurement with a thinner feeler gauge than the clearance that you expect to find.

The best roller ring position during measurements, especially if the true clearance is wanted, is their normal equilibrium position. To obtain this position, the bearing should be rotated a few times.

It's easier to rotate, avoiding varying misalignment, the outer ring than the inner ring. Misaligned spherical roller bearing outer rings aren't a problem since the outer ring raceway is a sphere. However, varying misalignment during rotation makes the roller move axially along the raceway as they roll and their position in the zone with clearance may not be the equilibrium position.

It was easier to find the correct roller position with the old, obsolete, spherical roller bearings with asymmetrical rollers and/or with middle integrated flange in the inner ring. You could just push the rollers against the flange. With modern, high-performance spherical roller bearings with symmetrical rollers and floating guide ring, you must first rotate the bearing. Then, if a roller moves during measurement, just gently push it back against the floating guide ring, but don't force it! The guide ring mustn't move.

Rule number 4: Find the equilibrium position by rotating the outer ring (if possible).

Recommendation: mount the bearing on the shaft and rotate the outer ring. For large, heavy bearings, place a clean rod in the lubricating holes on the outer ring. It will help you rotate the ring. Fig. 7 shows one of my colleagues, retired now, using a clean screw driver to do this.

The CARB toroidal roller bearing is a tricky bearing since its clearance changes as soon as one ring moves in relation to the other due to misalignment and axial displacement and/or as soon as rollers move axially. As such, we recommend that that the feeler gauge

method should be avoided when mounting CARB toroidal roller bearings unless the fitters are well-trained and very experienced.

Well-trained fitters and engineers, knowing how spherical roller bearings and CARB toroidal roller bearings work, are able to put the elements of a bearing back in position to continue the clearance reduction after an unexpected movement.

Measuring the real internal radial clearance isn't always needed. It is needed when there is a risk that the residual radial clearance after mounting could be below the permissible values indicated in the SKF General Catalogue.

Minimum permissible clearance value?

During operation, due to temperature differences between the bearing rings, the internal clearance will decrease. Bearings can run with no clearance or a small preload which increases the bearing life, but in this case the clearance has to be adjusted very accurately and the operating conditions need to be well known. In general, it is preferable to recommend a minimum residual clearance to avoid the risk of too high preload especially when a mounting method isn't accurate enough.

Please remember that the choice of the correct interference fit depends on the application and the operating conditions. Normally, the clearance reduction shouldn't depend on the initial clearance and the residual permissible clearance value. Instead, it should be based on the operating conditions and the interference fit needed. The radial clearance class of the bearing should be chosen to have the correct operating radial clearance (or preload).

When no information about running conditions are available and/or there isn't someone able to confirm that the residual radial clearance after mounting is sufficient, it's preferable to keep a radial clearance above the minimum recommended by SKF.

Unfortunately, some people focus too much on the minimum permissible clearance value. Maybe it should be ignored?

It's worth stressing that the minimum permissible clearance value isn't the clearance that you have to reach. If you want to reach that clearance, you will probably be obliged to drive-up the bearing much further than is recommended. For instance, it can be more than twice the maximum recommended drive-up for C5 clearance bearings. This would create high stresses in the inner ring.

Rule number 5: The minimum permissible clearance value is not a clearance that you have to reach. It is a minimum value given as a general recommendation.

When mounting a spherical roller bearing on a drying cylinder with the feeler gauge method, I don't waste my time trying to find the true radial clearance. I know to aim for a clearance reduction in the lower half of the recommended range as, due to "light" load, you do not need a very tight fit. Furthermore, because it is a C4 clearance class, I will never get a residual radial clearance after mounting under the minimum permissible. The important thing is to achieve the correct clearance reduction.

Anyway, if you look carefully at the SKF recommendations, you will see that the minimum clearance for a C4 bearing minus the maximum recommended clearance reduction always gives the minimum permissible clearance. That means that with a C4 class or a C5 spherical roller bearing, as long as the clearance reduction is within the recommended range, the residual clearance after mounting will

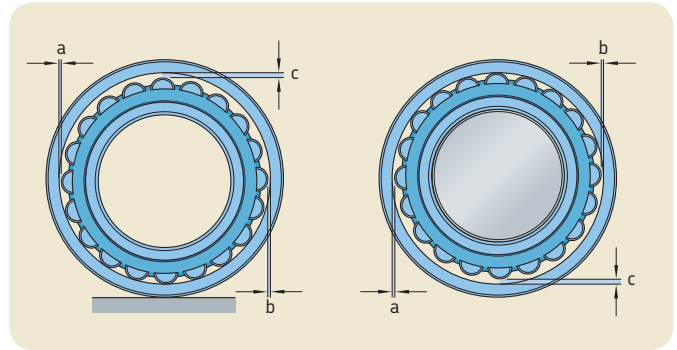

Fig. 8.

always be above the minimum permissible. So, don't waste your time trying to find the true clearance in such cases.

Rule number 6: For C4 and C5 clearance class spherical roller bearings, you only need to have accurate clearance reduction. You don't need to bother about the true clearance.

If you do not feel comfortable deciding that the residual clearance after mounting can be below the minimum permissible, you better take the time to find the true clearance of the unmounted bearing.

Finding the true clearance:

To be able to measure the true clearance, the bearing has to have its rollers in their normal equilibrium position. That said, outer and inner rings don't need to be perfectly concentric if the bearing is a spherical roller bearing.

One major problem is that the bearing is flexible. It deforms under its own weight. This means that the clearance measured at the 12 o'clock position in a bearing standing upright on the shop floor is smaller than the clearance measured at the 6 o'clock position in the same bearing hanging from a strap or loosely fitted on a shaft. The thinner section the bearing is and the bigger it is, the larger the deflection and the variation between the true clearance and the measured one.

To approach the true clearance, check the clearance at 12 o'clock (c) of a bearing standing on the floor, or at 6 o'clock for a bearing hanging on a shaft. Then measure simultaneously the clearance at position 3 o'clock (b) and 9 o'clock (a) (→ fig. 8).

The best estimation of the true clearance is given by: $(a+b+c)/2$.

If the rings were perfectly round, $a=b=c/2$. This is why the formula is $(a+b+c)/2$ and isn't $(a+b+c)/3$.

Rule number 7: Clearance = $(a+b+c)/2$

Some people try to pass long feeler gauges over two rollers, one on each row of the spherical roller bearing. I don't like this approach and only do it if I have no access to one of the rows. I would recommend checking one row and then the other. If I do not find roughly the same clearance on the two rows, I rotate the outer ring again and take new measurements.

Clearance reduction value

In the SKF General Catalogue, SKF doesn't give one clearance reduction value, but a range.

Example: Bearing 23040 CCK/W33. This bearing has a 200 mm bore diameter.

Based on **table 1, page 7**, the clearance reduction recommended is between 0,090 and 0,130 mm to have enough, but not too much, interference fit in general applications.

So, should the reduction be near the minimum value of the range (0,090) or near the maximum (0,130)? It depends on the operating conditions. Take another look at what I wrote about the interference fit. That said, if you do not know the operating conditions, my advice is to focus on the middle of the range and a little bit above (0,110–0,120 mm) and be careful about the minimum permissible clearance.

Rule number 8: Table 1 should be considered as a general guideline that can be followed (or not) based on known operating conditions and the fitter's experience.

The clearance reduction range is valid whatever the clearance class of the bearing (normal, C3, C4 etc.). The clearance class of a bearing is chosen based on the operating conditions and for an adequate interference fit. The interference fit isn't chosen based on the clearance class.

Some believe that the clearance should be reduced to half of the true clearance. This is wrong and can lead to too high drive-up. This will then create high stresses in the inner ring.

Rule number 9: The clearance reduction range is valid whatever the clearance class of the bearing. It can be modified so ensure that the residual clearance after mounting isn't lower than the permissible clearance.

This means that with our example of the 23040 CCK/W33, the 23040 CCK/C3W33 and/or the 23040 CCK/C4W33 will be mounted with the same clearance reduction range (0,090 to 0,130 mm), except if the operating conditions (or lack of knowledge about operating conditions) oblige us to select above minimum permissible clearance.

Minimum permissible clearance, from **table 1**, for :

23040 CCK/W33	(normal clearance class)	0,070 mm
23040 CCK/C3W33	(C3 class)	0,100 mm
23040 CCK/C4W33	(C4 class)	0,160 mm

Note that we don't really care about the minimum value for the C4 or C5 class.

Let's continue with the 23040 CCK/W33 example to show how the minimum permissible clearance can influence the clearance reduction.

If the bearing has a true clearance of 0,210 mm, the radial residual clearance after drive up should be between:

$$0,210 - 0,130 = 0,080 \text{ mm}$$

and

$$0,210 - 0,090 = 0,120 \text{ mm}$$

The minimum value of the calculated residual clearance is 0,080 mm, which is above the 0,070 mm (the minimum permissible)

clearance). So, in this case, the clearance reduction range is kept between 0,090 and 0,130 mm.

But, if the bearing has a true clearance of 0,170 mm, the radial residual clearance after drive up should be between:

$$0,170 - 0,130 = 0,040 \text{ mm}$$

and

$$0,170 - 0,090 = 0,080 \text{ mm}$$

Unfortunately, the minimum value of the calculated residual clearance is 0,040 mm, which is below the 0,070 mm (the minimum permissible). So, in this case, the clearance reduction range has to be changed and reduced to be between 0,090 and 0,100 mm ($170 - 70 = 100$). The residual clearance after drive up will then be in a smaller calculated range, from 0,070 to 0,080 mm.

Now that the clearance reduction range is known or calculated, it is time to do the drive-up of the bearing.

You don't need to take care of the true clearance value anymore. The important thing is to get the correct clearance reduction.

For the bearing 23040 CCK/W33, the true clearance is 0,170 mm and the clearance reduction between 0,090 and 0,100 mm. The fact is that once the bearing is on the shaft, if the fitter measures 0,160 mm or 0,180 mm over one roller after rotating (if possible) the bearing to put the rollers in their equilibrium position, it isn't a problem.

If a fitter measures 0,160 mm, the residual clearance should be between:

$$0,160 - 0,100 = 0,060 \text{ mm}$$

and

$$0,160 - 0,090 = 0,070 \text{ mm}$$

If another fitter measures 0,180 mm, the residual clearance should be between:

$$0,180 - 0,100 = 0,080 \text{ mm}$$

and

$$0,180 - 0,090 = 0,090 \text{ mm.}$$

These two fitters have done the same clearance reduction and thus the same drive-up giving the same interference fit for the same bearing.

Rule number 10: Rules number 1 and 2 are really important.

Rule number 11: During drive-up, the true clearance of the bearing isn't important, the chosen and/or calculated clearance reduction is.

Some important points

The narrower the range of the clearance reduction, the slower the bearing must be driven up its taper seat to avoid exceeding the maximum value of the clearance reduction range. To avoid too high drive-up, and to avoid moving the bearing suddenly during drive-up and exceeding maximum clearance reduction value, oil the sliding surfaces. The sliding surface is the contact surface between the bearing and its seat. If the bearing is mounted on an adapter sleeve or a dismounting sleeve, there can be a second sliding surface be-

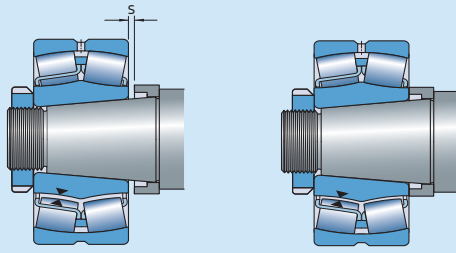

Bore diameter		Reduction of radial internal clearance		Axial drive-up ¹⁾				Residual ²⁾ radial clearance after mounting bearings with initial clearance			Lock nut tightening angle	
d				s	Taper 1:12		Taper 1:30		Normal	C3	C4	α
over	incl.	min	max	min	max	min	max					Taper 1:12
mm		mm		mm				mm			degrees	
24	30	0,015	0,020	0,3	0,35	–	–	0,015	0,020	0,035	110	
30	40	0,020	0,025	0,35	0,4	–	–	0,015	0,025	0,040	120	
40	50	0,025	0,030	0,4	0,45	–	–	0,020	0,030	0,050	130	
50	65	0,030	0,040	0,45	0,6	3	4	0,025	0,035	0,055	110	
65	80	0,040	0,050	0,6	0,7	3,2	4,2	0,025	0,040	0,070	130	
80	100	0,045	0,060	0,7	0,9	1,7	2,2	0,035	0,050	0,080	150	
100	120	0,050	0,070	0,75	1,1	1,9	2,7	0,050	0,065	0,100	–	
120	140	0,065	0,090	1,1	1,4	2,7	3,5	0,055	0,080	0,110	–	
140	160	0,075	0,100	1,2	1,6	3	4	0,055	0,090	0,130	–	
160	180	0,080	0,110	1,3	1,7	3,2	4,2	0,060	0,100	0,150	–	
180	200	0,090	0,130	1,4	2	3,5	5	0,070	0,100	0,160	–	
200	225	0,100	0,140	1,6	2,2	4	5,5	0,080	0,120	0,180	–	
225	250	0,110	0,150	1,7	2,4	4,2	6	0,090	0,130	0,200	–	
250	280	0,120	0,170	1,9	2,7	4,7	6,7	0,100	0,140	0,220	–	
280	315	0,130	0,190	2	3	5	7,5	0,110	0,150	0,240	–	
315	355	0,150	0,210	2,4	3,3	6	8,2	0,120	0,170	0,260	–	
355	400	0,170	0,230	2,6	3,6	6,5	9	0,130	0,190	0,290	–	
400	450	0,200	0,260	3,1	4	7,7	10	0,130	0,200	0,310	–	
450	500	0,210	0,280	3,3	4,4	8,2	11	0,160	0,230	0,350	–	
500	560	0,240	0,320	3,7	5	9,2	12,5	0,170	0,250	0,360	–	
560	630	0,260	0,350	4	5,4	10	13,5	0,200	0,290	0,410	–	
630	710	0,300	0,400	4,6	6,2	11,5	15,5	0,210	0,310	0,450	–	
710	800	0,340	0,450	5,3	7	13,3	17,5	0,230	0,350	0,510	–	
800	900	0,370	0,500	5,7	7,8	14,3	19,5	0,270	0,390	0,570	–	
900	1 000	0,410	0,550	6,3	8,5	15,8	21	0,300	0,430	0,640	–	
1 000	1 120	0,450	0,600	6,8	9	17	23	0,320	0,480	0,700	–	
1 120	1 250	0,490	0,650	7,4	9,8	18,5	25	0,340	0,540	0,770	–	
1 250	1 400	0,550	0,720	8,3	10,8	21	27	0,360	0,590	0,840	–	
1 400	1 600	0,600	0,800	9,1	11,9	22,7	29,8	0,400	0,650	0,920	–	
1 600	1 800	0,670	0,900	10,2	13,4	25,4	33,6	0,440	0,720	1,020	–	

¹⁾ Valid only for solid steel shafts and general application. Not valid for the SKF Drive-up Method

²⁾ The residual clearance must be checked in cases where the initial radial internal clearance is in the lower half of the tolerance range, and where large temperature differentials between the bearing rings can arise in operation

Table 1. Recommended values for reduction of radial internal clearance, axial drive-up and lock nut tightening angle.
Table 6, page 711, SKF General Catalogue 6000/1.

tween the sleeve and the shaft, if the sleeve moves along the shaft during drive-up.

Rule number 12: Oil the sliding surfaces.

For small bearings mounted with a locking washer, do not drive up the bearing by tightening the lock nut with the locking washer in place. Friction between the lock nut and the locking washer can force the washer to rotate which can damage it. The bore tongue can be torn away, leaving the nut without being locked in rotation.

Rule number 13: Do not drive up the bearing with the locking washer between the bearing and the lock nut.

When drive-up is finished, do not unscrew the lock nut or release hydraulic pressure too quickly. The excess of oil in the contact surface must escape. Otherwise, the bearing can move axially down the taper. Depending on bearing size, let the bearing settle for 10 or 20 minutes.

Rule number 14: Once the clearance reduction is done, take a coffee break.

If a too thick feeler gauge is used, it will be difficult to get it to follow the curvature of the raceways and roller and clearance measurement accuracy will be decreased. It is better to use two thinner feeler gauges to take the measurement. So, use a 0,300 mm and a 0,200 mm gauge rather than a 0,500 mm one.

Checking bearing wear with a feeler gauge.

Checking bearing wear with a feeler gauge isn't recommended.

- 1 You need to measure the clearance with the same load (direction, intensity) on the bearing. Under load, the bearing deforms and the clearance increases. So, it is useless to compare the residual clearance of the bearing just after drive-up (no load) and the clearance of a loaded bearing on the machine.
- 2 Because of thermal expansion and/or axial load, the outer ring might not be in the same position in the housing and/or the inner ring might not be in the same relative position compared to the outer ring between two measurements. If clearances on both roller rows aren't measured, large differences can be found.
- 3 Spalls or/and dents might not be big enough to make the clearance increase, but the bearing is damaged.
- 4 You cannot accurately compare measurements done with feeler gauges if the measurements are done by two different people.

Conclusions

The feeler gauge method for mounting bearings with tapered bores is an old method that has been proven to be accurate enough for many, but not all, applications. This method relies mainly on the fitter's experience and feeling. Furthermore, too often this method has been transmitted from one person to another by word of mouth thereby increasing the risk of bad practices.

Trying to find the clearance without moving the rollers with feeler gauges is old-fashioned. Try the SKF Drive-up Method or SKF SensorMount and you will understand this.

The case of the failed shaker screen bearing

Sam, the maintenance man, was on the first of several daily routine tours of the mill, a five machine with integrated kraft pulp mill. He headed first to the brown stock area knowing that last night a call in to replace the bearings on the deknotted rejects vibrating screen had taken place. He wanted to know more about the circumstances before the morning meeting at 09:00. The best way to find out was to visit the site and ask Marvin.

Marvin was the area Basic Care Mechanic (BCM). Each operating area in the mill had a full time mechanic who took responsibility for monitoring the equipment's condition and tweaking the performance when applicable, for example, adjusting packing gland water flow or tightening packing, changing filters on ventilating systems, etc. Marvin knew every piece of equipment in his assigned area better than anyone else in the mill and there were more like him in every other area.

"Morning, Marvin." Sam said as he approached Marvin at the brown stock elevator. "Heard you had a problem last night."

"You heard right." Marvin responded, looking to see if Sam would make eye contact. Sam always made eye contact, with everyone, every time.

"So, tell me, what happened?"

"Lost the bearings on the knotted shaker screen, again." Marvin responded.

Actually the equipment was a vibrating conveyor with perforated plates that conveyed the knots, fibre bundles that wouldn't pass through the perforations, in to a tank for further refining or disposal. The stream of brown stock entering the head end of the screen was the rejects line from the deknotted. Fibre losses were reported daily and thus managed by the various area operations managers. This incident would be reported in the morning meeting.

"So, Marv, what do you suppose caused the failures?"

"I don't suppose anything; I know what caused the failures." Marvin was the type of person that when responding to a question had two answers, the truth and silence.

"I'm listening." Sam had learned how to coax the conversation along without drawing the ire of Marvin. Wasn't an easy lesson, but it was a quick one.

"Cages failed."

"Cages failed?"

"Yes."

"Why?"

"That's the right question."

"I'm listening."

"They were brass."

"What?"

"They weren't steel."

"This has happened before."

"Yes."

"I thought we had stopped that from happening again." Several years ago, these same bearings had failed and Marvin realized, almost immediately that the bearings being provided by the storeroom were supplied with brass cages. Caustic and brass don't react well. Sort of like sucking on a piece of hard candy, eventually there is nothing left.

At the time, the solution was to specify that this bearing was never to be supplied with a brass cage, only steel.

"Seems not."

"How did these get put in?"

"Call in a couple of weeks ago."

"So this is what was in stores?"

Silence. "Okay, Marv, I'll check it out, thanks."

Back in his office, Sam logged on to the CMMS, found the shaker screen in the hierarchy and brought that up. In big bold letters in the bill of materials was the note to use only bearings with a steel cage (actually identified by manufacturer).

Sam went to the storeroom inventory screen and looked up the bearing. Recent transactions showed a shipment received from the vendor in order to bring the inventory back up to the correct stocking levels. Sam went to the purchasing module and found the purchase order for the bearings and a lot of other stuff from one of the local power transmission vendors. There was no specific bearing manufacturer identified.

During the morning production meeting, the pulp mill manager explained that their fibre losses were higher than usual because the knotter screen bearings had failed, again, resulting in bypassing the knotter rejects recirculating tank. The mill manager looked at Sam for an explanation.

"Seems the action we took a year or so back wasn't the complete solution." Sam said looking around the table and making eye contact with those staring back. "We had made a note in the asset record that only Brand X bearings were to be used because they supplied a steel cage and not a brass cage, which as you know dissolves in the presence of caustic. The assumption, a poor one obviously, was that anyone working on the replacement of the bearings for whatever reason would check the asset record in the CMMS before performing the work and find this note."

"The other assumption, again erroneous, was that the store's request for replenishment would have the manufacturer specified so that purchasing would specifically request that brand. That did not happen." Sam continued. "Seems we have some training issues, perhaps a cultural issue and I will follow through on this personally,

but I will also make sure it is entered into the LTA (Lost Time Analysis program used for root cause analysis in the mill)."

Looking at the pulp mill manager, Sam said, "I'm sorry our fibre losses were high as a result of this failure and I hope that doesn't have any further consequences. I'm glad we didn't suffer any downtime, although it's conceivable the same mistake could have been used on critical equipment."

"Good enough, Sam," the mill manager injected, "report back to us on any progress made."

Sam learned that typically on call ins, few of the mechanics went to the CMMS to look up information about the equipment in question. They would simply start the job, in this case dismantle the screen basket to get to the bearings, use the remains of the bearing to identify the part number (bearing number) and go directly to the storeroom for a replacement.

Sam learned that although there was a note in the asset record, there was no corresponding note in the bearing's inventory record stating a preference for the manufacturer.

Sam determined the technology (CMMS) would support all of these requirements and more, however the business process defined had simply been incorrect and incomplete, and the culture had not adjusted to the new correct process and technology.

As usual follow up had been needed, but had not been performed. A lesson learned, and now the learning needed to be applied.

John Yolton is approaching his 46th year in the industry. A many-journeyed, seasoned veteran of pulp and paper manufacturing, Yolton currently assists global paper industry clients with asset reliability improvement strategies. He can be contacted at john.yolton@skf.com.



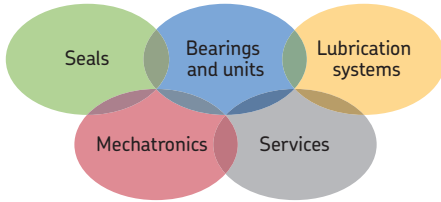

The Power of Knowledge Engineering

Drawing on five areas of competence and application-specific expertise amassed over more than 100 years, SKF brings innovative solutions to OEMs and production facilities in every major industry worldwide. These five competence areas include bearings and units, seals, lubrication systems, mechatronics (combining mechanics and electronics into intelligent systems), and a wide range of services, from 3-D computer modelling to advanced condition monitoring and reliability and asset management systems. A global presence provides SKF customers uniform quality standards and worldwide product availability.

SKF Global Pulp & Paper Segment

Contact/Responsible editor
philippe.gachet@skf.com

© SKF, CARB and SensorMount are registered trademarks of the SKF Group.

© SKF Group 2011

The contents of this publication are the copyright of the publisher and may not be reproduced (even extracts) unless prior written permission is granted. Every care has been taken to ensure the accuracy of the information contained in this publication but no liability can be accepted for any loss or damage whether direct, indirect or consequential arising out of the use of the information contained herein.

PUB 72/S9 11147 EN · January 2011





Philippe Gachet using a wire tool to check the condition of the raceway on a felt roll bearing.

Back in time

You might wonder why SKF decided to publish his newsletter. Well, it's a long story that started, back in 1994, when the SKF Ball Bearing Journal was retired and replaced by Evolution magazine. The Ball Bearing Journal, which was published from 1926 to 1994, was very much a technical publication. Evolution, in contrast, has a different and more general focus,

I was working as an application engineer for SKF France at the time. A number of maintenance people from paper mills and design engineers from companies manufacturing process machinery contacted me to say they still needed a technical publication like the Ball Bearing Journal. As a result, the French language SKF Info Papeterie was born. It was a simple, black and white, photocopied document with technical content for engineers and practical recommendations for service people. Most of the articles were based on the questions that I was asked and the practices that I sometimes saw when visiting mills.

SKF Info Papeterie stopped, after 20 issues, when I took up a new position in SKF's global pulp and paper segment team. Last year, we decided to revive it. However, as I'm working in a global role, it had to become global too and it ended up being renamed SKF Pulp & Paper Practices.

For this edition of SKF Pulp & Paper Practices, I have decided to write about internal clearance in spherical roller bearings before moving on to cover modern mounting methods in the third issue. The reason for this is that many people are surprised to learn that

clearance reduction is not to obtain the correct clearance, but it is to get the correct tight fit of the inner ring. So the question: "But, what about the bearing clearance?" comes up quite often.

Regarding clearance reduction, the feeler gauge method was covered in this last issue, but it will have to be updated soon. Our recommended values for the reduction of internal clearance will change and the minimum permissible values will disappear by the end of this year. This will have no influence on modern mounting methods for bearings with tapered bores, like the SKF Drive-up Method and SensorMount, which will be explained in the next issue.

Now, I'll leave you to read the second issue of SKF Pulp & Paper Practices. Feedback about the first one was very positive which is highly motivating for us. Please feel free to contact us if you have questions or feedback.

*Regards,
Philippe Gachet*



Rolling bearings in paper machines

The 4th edition of this handbook for the paper machine designers and operators is available now. The publication number is 10580 EN and it is available for download from skf.com.

C4 instead of C3

Sometimes, specific bearing variants are not available and yet the same type with a different radial clearance class is. Can that be used instead? For example, can you mount a 22316 EK/C3 on your felt rolls instead of a 22316 EK? This type of question comes up quite often. So, let's have a look at the different clearance classes, how they are selected and what can happen if you change the clearance class for an application.

In this article we will focus on spherical roller bearings. Much of what is written here is also relevant to other types of bearings e.g. cylindrical roller or deep groove ball bearings. However, it is not relevant to all bearing types and bearing arrangements. For CARB toroidal roller bearing, the basis is the same as with spherical roller bearings but, additionally, radial clearance will change according to the axial offset and/or the misalignment of the inner ring relative to the outer ring.

Before answering some frequently asked questions, let's look at the basics: what radial clearance class is; what influence does it have on bearing life; running accuracy and how clearance class is chosen.

Basics

Radial clearance class

The exact radial clearance of a bearing is the possible radial displacement of the inner ring relative to the outer ring. This radial clearance depends on the diameters of the raceways, the roller diameters and, for the spherical roller bearing, the position of the raceways on the inner ring (→ fig. 1).

For practical reasons, bearings are not supplied with an exact radial clearance. Rather, they come with a clearance which fits into a range specified in ISO 5753:1991.

Radial clearance class is indicated by a suffix on the bearing designation. These suffixes, from the smallest to the largest, are: C1, C2, CN, C3, C4 and C5. CN is considered to be the standard clearance class and is not included in the bearing designation.

Example with a 22320 EK:

	the radial clearance is
22320 EK/C1	0,035 to 0,055 mm
22320 EK/C2	0,055 to 0,080 mm
22320 EK	0,080 to 0,110 mm (suffix CN is omitted)
22320 EK/C3	0,110 to 0,140 mm
22320 EK/C4	0,140 to 0,180 mm
22320 EK/C5	0,180 to 0,230 mm

In addition, letters can be added to the clearance class for reduced or displaced tolerances.

C3L	means the lower half of C3
C3H	means the upper half of C3
C3P	means the upper half of C3 with the lower half of C4
C3M	means the upper half of C3L with the lower half of C3H

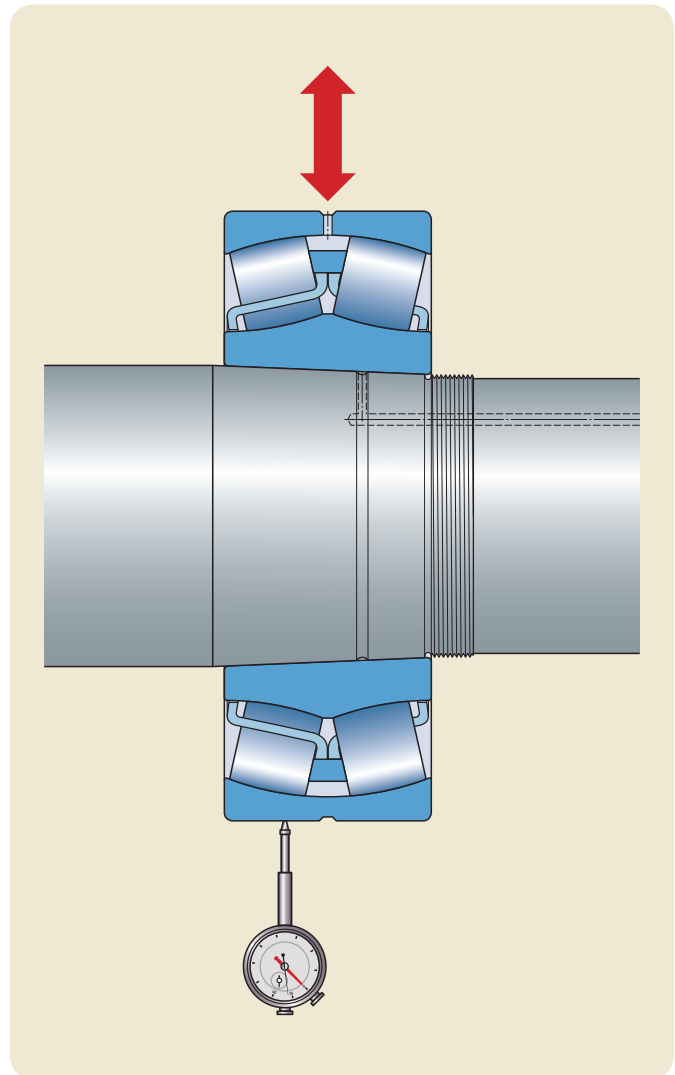

Fig. 1.

In some cases, the clearance class is part of another suffix. For spherical roller bearing mounted on paper machines, the most common are C083 and C084. C08 denotes bearings with improved running accuracy. So, C083 indicates a bearing with improved running accuracy and C3 clearance class.

The radial clearance class should be chosen based on the application i.e. the operating conditions (speed, load, lubrication, heat transfer), any clearance reduction due to interference fits and take in consideration the start-up conditions.

The effect of radial clearance on bearing life

Fig. 2 shows that the bearing with the larger clearance has less rollers supporting the load. Consequently, the load per roller and the contact pressure on the most loaded roller is also much larger. In such a situation, the fatigue life will be lower than for the other bearing.

When calculating the nominal bearing life with the ISO method, clearance in the bearing is supposed to be equal to zero (no clearance, no preload), which corresponds to 50% of the rollers loaded.

If the bearing has no clearance and a small preload, the overall load on the bearing will be larger, but that on the most loaded roller will be lower since load is better distributed over all the rollers. This

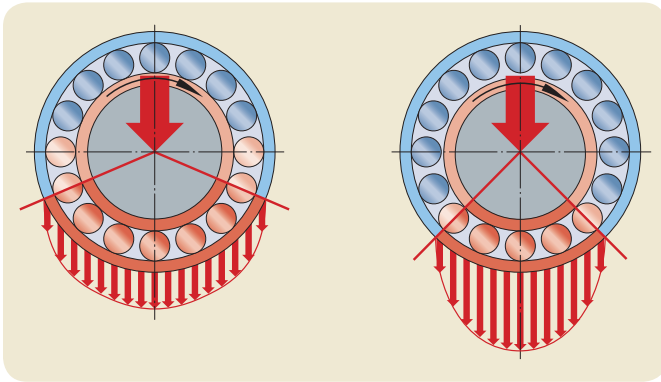

Fig. 2.

means that the fatigue life of the bearing increases. However, if preload becomes too heavy, fatigue life rapidly decreases (see the red curve in **fig. 3**)

In reality, this isn't as simple because the housing isn't totally rigid. A housing is flexible and, as the outer ring of the bearing tends to take to shape of its seat in the housing, the load distribution can be quite different (→ **fig. 4**).

The fatigue life curve (in red on **fig. 3**) will then change, but there will always be a rapid fall if there is too much preload and a fatigue life decrease when clearance becomes too large.

Clearance and preload also have an influence on friction and, therefore, the heat generated by the bearing. To make it simple, the smaller the clearance, the higher the friction. Friction also increases rapidly with preload.

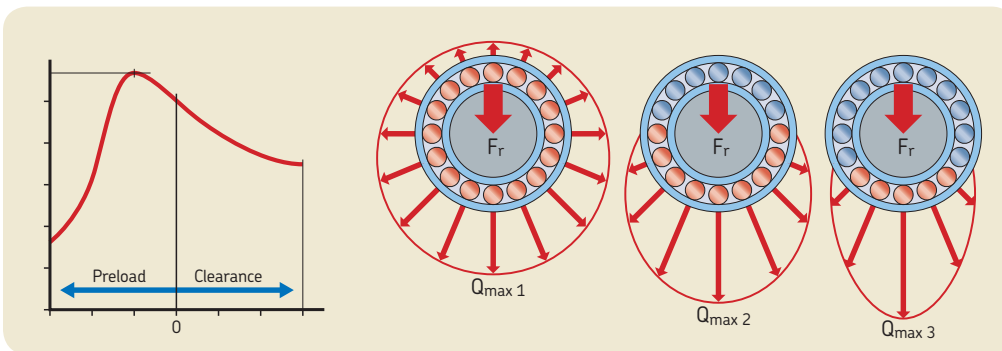

Fig. 3.

The influence of radial clearance on running accuracy

Figure 5 shows a bearing with too much clearance but perfectly round rings and rollers.

If the load is always in the same direction, the relative position of the inner ring compared to the outer ring will remain the same. However, if the load moves to the 3 o'clock position (indicated by the red arrow with the dotted outline), the centre of the inner ring will move upwards to the right. In case of varying load direction, the smaller the clearance in operation, the better the running accuracy.

For some applications needing very high running accuracy, such as printing presses, a spherical roller bearing with higher running accuracy can be mounted with preload (negative clearance). Depending on the

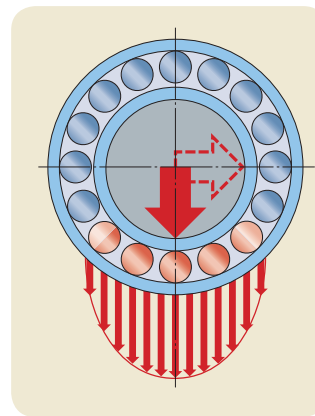

Fig. 5.

mounting method and the operating conditions, these spherical roller bearings can run with a slight preload without risk of going into a too high preload zone.

In some pulp mills, and even in some paper mills, you can find screw presses where the axial load is taken by a spherical roller thrust bearing and the radial load by a radial spherical roller bearing mounted as shown in **fig 6, page 4**.

The thrust bearing is mounted, radially free, in the housing so that it doesn't take any radial load. When the raw material is pressed, a rotating radial load is created and its magnitude can be bigger than the radial load due to the weight of the screw. The spherical roller bearing then is subject to a rotating load on its outer ring. The inner ring, and thus the shaft, will have some radial displacement depending on the internal clearance and whether the bearing is mounted with a loose fit in the housing. It will depend also

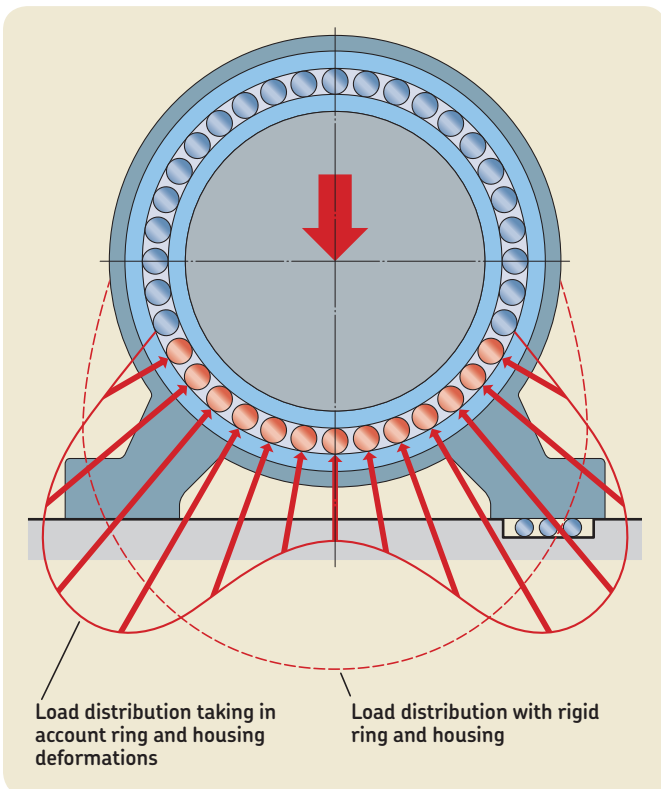

Fig. 4.

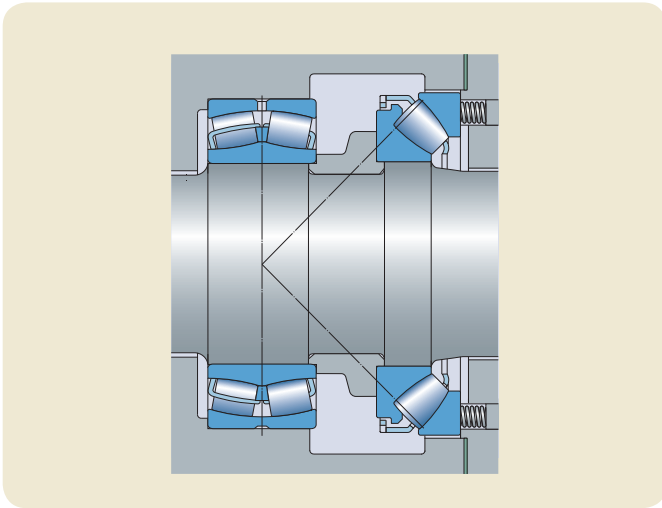

Fig. 6.

on the clearance between the outer ring and the housing. This will make the inner ring (shaft washer) of the thrust bearing experience radial displacement and, in consequence, the outer ring (housing washer) as well (→ fig. 7).

This results in the outer ring (housing washer) of the thrust bearing being forced to perform a scuffing movement against its seat surface to an extent which corresponds to the internal radial clearance and the magnitude of the loose fit of the radial bearing. In many cases this leads to premature failures.

Runout of the raceways (running accuracy) also has an influence. For information, the SKF standard spherical roller bearings and CARB toroidal roller bearings up to 300 mm bore diameter have a P5 running accuracy. This is four times better than the normal ISO standard.

Please remember that the overall running accuracy of a roll press, for example, also depends on other factors such as the bearing seat forms, roll forms, coaxiality between bearing seat and roll part, position of the inner ring high eccentricity point relative to the bearing seat high eccentricity point etc.

What clearance class to choose?

A tight fit of the bearing on and/or in its seat depends on load intensity and direction. Tight fits reduce radial clearance.

In general, though it's not always the case, the bearing inner ring runs hotter than the outer ring. The higher the speed and the higher the load, the larger the temperature difference between outer and inner rings. Furthermore, the higher the operating temperature, the more the roller diameter expands. This decreases the radial clearance in the bearing.

Start-up must be taken into account since during start-up the inner ring temperature increases more quickly than the outer ring. During start-up, the clearance decreases and after a while increases. That said, it stays smaller than is the case when the machine is cold. This phenomenon is accentuated when the shaft or journal is heated e.g. drying cylinders, heated calenders, Yankees. **Diagram 1** shows the temperature difference between the inner ring and the outer ring during start-up.

As an example, if there was no start-up and the bearings were always running in steady state conditions, C4 clearance class would not be a good option for drying cylinder bearings. C3 clearance class

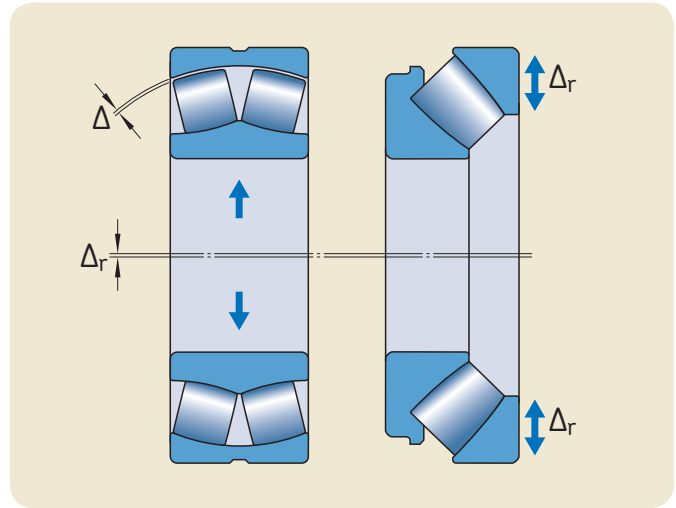

Fig. 7.

would be preferable due to superior load distribution. To prove it, you just need to look at the load zone of a bearing mounted on a drying cylinder. On average, it's a 90–120° angle. This indicates that the bearing is running with too much clearance at a steady state operating temperature. However, if a C3 clearance class bearing was used, there is the risk of excessive preload because the inner and outer ring temperature difference would have completely removed any clearance during start-up.

Dimensional stability is another important issue when temperatures are high. Structural changes in bearing steel occur and dimensions alter. Unstabilized martensitically heat treated rings experience the biggest changes. They expand initially and then contract.

Diagram 2 shows the diameter variation at 200 °C for martensitic steel that has been stabilized for 120 °C and for a bainitic steel that is stabilized for 200 °C. Remember that all SKF spherical roller bearings and CARB toroidal roller bearings are stabilized for 200 °C.

Bearing mounting procedures and the machine environment must also be taken into account. If the bearing will be mounted with a low accuracy mounting method such as feeler gauges; if the bearing is likely to be over-greased or if the ambient temperature varies a lot, then it will be difficult to hold a precise operating clearance. Even if a bearing clearance class is chosen that gives, in theory, an optimum operating clearance, there is a risk that it will be pre-loaded during operation in reality. For this reason, most radial clearance

Diagram 1.

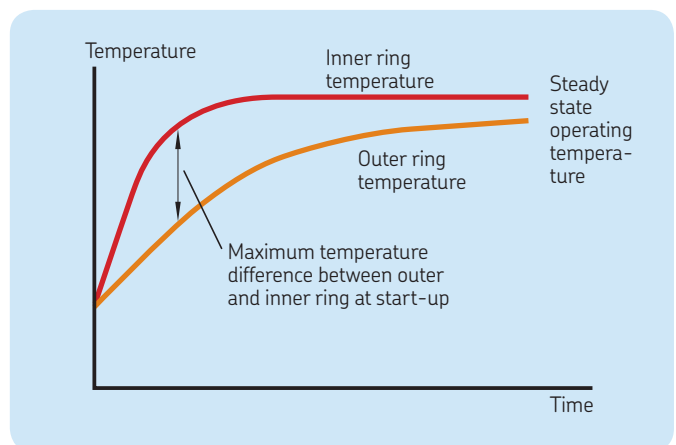

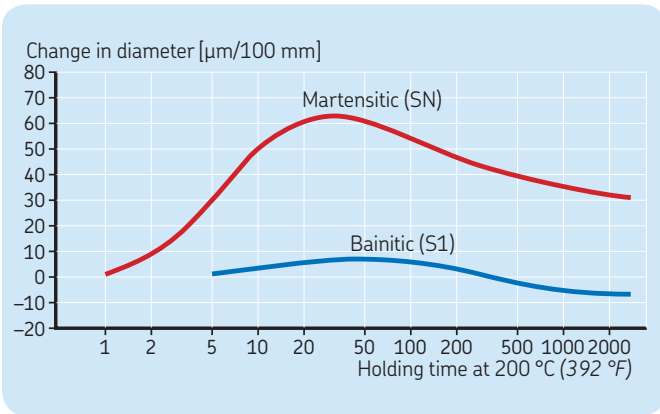

Diagram 2.

classes are selected and most bearings are mounted so that they will run with clearance even if this isn't optimal from a fatigue life point of view.

By the way

- Never blow cool air on a housing if the bearing is overheating. It can increase the temperature difference between the outer and inner rings and create catastrophic pre-load
- Be careful if you increase oil flow or relubricate when a bearing is overheating. It could be overheating due to an excess of lubricant

Choosing the correct clearance class may seem complicated if it is not specified by the machine supplier. In some cases, it can be complicated since speed, load, type of lubrication, external cooling, shaft material and geometry, housing material and geometry, the fits, heat transfer and even the color of the housing can influence the temperature differences between inner and outer ring. But, for general use which represents more than 90% of the applications, the SKF General Catalogue gives the information. It isn't straightforward and the solution might come after several iterations:

- 1 Choose bearing type and size based on the loads
- 2 Choose the correct fits based on the loads. The SKF General Catalogue indicates if a greater clearance class is needed or not. More precise information will be given in future article about how to choose fits
- 3 Calculate the new reference speed based on the load and the lubrication. We will also be more precise about this issue in a future article about speed limits.

Let's look at a quick example

Quick means a quick way to determine a clearance class that allows the bearing to operate without too much clearance and without a dangerous preload. It will not always give the optimum clearance class. It needs a bit of experience, but it works.

A felt roll spherical roller bearing, 22222 EK, rotates at 200 r/min and is quite heavily loaded due to a new felt tension as a result of a machine speed increase. The load equivalent dynamic load, P, calculated with the radial and axial load (estimation based on the friction between outer ring and housing in the non-located position. N.B. this doesn't exist if CARB toroidal roller bearings are used in the

non-located position) is near 96 kN. The bearing is grease lubricated with grease having 220 mm²/s at 40 °C base oil viscosity.

The dynamic basic load rating of the bearing, C, is equal to 560 kN.

The static basic load rating of the bearing, C₀, is equal to 640 kN.

First let's see what the SKF General Catalogue indicates concerning the fit on the shaft.

Even if the bearing has a taper bore (suffix K), it is good to have a look at the indications for cylindrical bore bearings (→ **table 1, page 6**).

$P/C = 96/560 = 0,17$ so the bearing is very heavily loaded.

The bearing bore is equal to 110 mm. The table says that the recommended fit is p6 and that a radial clearance greater than normal is recommended. By deduction, it can be said that the bearing with taper bore should be driven up it's seat in the upper half of the drive up range and thus take a C3 clearance class.

Now, let's look at the reference speed. The reference speed, which is 3 000 r/min for the SKF 22222 EK, represents the speed, under specific operating conditions, at which there is equilibrium between the heat that is generated by the bearing and the heat that is dissipated. If the bearing operates in different conditions than those used for calculating the reference speed a new speed, called permissible speed, has to be calculated. Bearings can run above permissible speed under certain conditions and one of the conditions is to take a greater clearance class. All this is given for a bearing running at 70 °C.

The corrective factor depends on load and viscosity. For grease lubrication :

$$n_{perm} = n_r f_p (f_{vactual} / f_{vISOVG150})$$

To determine if a greater clearance class is needed for the SKF 22222 EK, the **diagram 3, page 7**, is needed.

$$D_m = \text{bearing means diameter} = 0,5 (d+D) \text{ [mm]}$$

$$d = \text{bore diameter [mm]}$$

$$D = \text{outside diameter [mm]}$$

For bearing 22222: $d_m = 0,5 (110+200) = 155 \text{ mm}$.

From diagram,
with $d_m = 155 \text{ mm}$ and $P/C_o = 0,15$,
 $f_p = 0,53$ and with $P/C_o = 0,15$ and ISO VG 220,
 $f_{vactual} = 0,83$; with $P/C_o = 0,15$ and ISOVG150, $f_{vISOVG150} = 0,87$. ⇒
 $n_{perm} = 3\,000 \times 0,53 \times 0,83/0,87 = 1\,520 \text{ r/min}$

As the rotating speed of the bearing is 200 r/min and is below 1 520 r/min, there is no need to select a greater clearance class than the one selected after looking at the fit.

The 22222 EK/C3 is chosen.

If you don't feel comfortable, call SKF. SKF application engineers have much more precise tools as their disposal for selecting adequate clearance class.

Radial bearings with cylindrical bore

Conditions	Examples	Shaft diameter, mm				Tolerance class
		Ball bearings ¹⁾	Cylindrical roller bearings	Tapered roller bearings	CARB and spherical roller bearings	
Rotating inner ring load or direction of load indeterminate						
Light and variable loads ($P \leq 0,05 C$)	Conveyors, lightly loaded gearbox bearings	≤ 17	–	–	–	js5 (h5) ²⁾
		(17) to 100	≤ 25	≤ 25	–	j6 (j5) ²⁾
		(100) to 140	(25) to 60	(25) to 60	–	k6
		–	(60) to 140	(60) to 140	–	m6
Normal to heavy loads ($P > 0,05 C$)	Bearing applications generally, electric motors, turbines, pumps, gearing, woodworking machines, wind mills	≤ 10	–	–	–	js5
		(10) to 17	–	–	–	j5 (js5) ²⁾
		(17) to 100	–	–	< 25	k5 ³⁾
		–	≤ 30	≤ 40	–	k6
		(100) to 140	(30) to 50	(40) to 65	25 to 40	m5
		(140) to 200	–	–	–	m6
		–	(50) to 65	–	(40) to 60	n5 ⁴⁾
		(200) to 500	(65) to 100	(65) to 200	(60) to 100	n6 ⁴⁾
		–	(100) to 280	(200) to 360	(100) to 200	p6 ⁵⁾
		> 500	–	–	–	p7 ⁴⁾
Heavy to very heavy loads and shock loads with difficult working conditions ($P > 0,1 C$)	Axleboxes for heavy railway vehicles, traction motors, rolling mills	–	(50) to 65	–	(50) to 70	n5 ⁴⁾
		–	(65) to 85	(50) to 110	–	n6 ⁴⁾
		–	(85) to 140	(110) to 200	(70) to 140	p6 ⁶⁾
		–	(140) to 300	(200) to 500	(140) to 280	r6 ⁷⁾
		–	(300) to 500	–	(280) to 400	s6 _{min} ± IT6/26 ⁸⁾
		–	> 500	> 500	> 400	s7 _{min} ± IT7/26 ⁸⁾
High demands on running accuracy with light loads ($P \leq 0,05 C$)	Machine tools	8 to 240	–	–	–	js4
		–	25 to 40	25 to 40	–	js4 (j5) ⁹⁾
		–	(40) to 140	(40) to 140	–	k4 (k5) ⁹⁾
		–	(140) to 200	(140) to 200	–	m5
		–	(200) to 500	(200) to 500	–	n5
Stationary inner ring load						
Easy axial displacement of inner ring on shaft desirable	Wheels on non-rotating axles					g6 ¹⁰⁾
Easy axial displacement of inner ring on shaft unnecessary	Tension pulleys, rope sheaves					h6
Axial loads only						
	Bearing applications of all kinds	≤ 250	–	≤ 250	≤ 250	j6
		> 250	–	> 250	> 250	js6

¹⁾ For normally to heavily loaded ball bearings ($P > 0,05 C$), radial clearance greater than Normal is often needed when the shaft tolerances in the table above are used. Sometimes the working conditions require tighter fits to prevent ball bearing inner rings from turning (creeping) on the shaft. If proper clearance, mostly larger than Normal clearance is selected, the tolerances below can then be used

- k4 for shaft diameters 10 to 17 mm
- k5 for shaft diameters (17) to 25 mm
- m5 for shaft diameters (25) to 140 mm
- n6 for shaft diameters (140) to 300 mm
- p6 for shaft diameters (300) to 500 mm

For additional information please contact the SKF application engineering service

²⁾ The tolerance in brackets applies to stainless steel bearings

³⁾ For stainless steel bearings within the diameter range 17 to 30 mm, tolerance j5 applies

⁴⁾ Bearings with radial internal clearance greater than Normal may be necessary

⁵⁾ Bearings with radial internal clearance greater than Normal are recommended for $d \leq 150$ mm. For $d > 150$ mm bearings with radial internal clearance greater than Normal may be necessary

⁶⁾ Bearings with radial internal clearance greater than Normal are recommended

⁷⁾ Bearings with radial internal clearance greater than Normal may be necessary. For cylindrical roller bearings radial internal clearance greater than Normal is recommended

⁸⁾ For tolerance values please consult the SKF Interactive Engineering Catalogue online at www.skf.com or the SKF application engineering service

⁹⁾ The tolerance in brackets apply to tapered roller bearings. For lightly loaded tapered roller bearings adjusted via the inner ring,

js5 or js6 should be used

¹⁰⁾ Tolerance f6 can be selected for large bearings to provide easy displacement

Table 1. Fits for solid steel shafts.

Table from SKF General Catalogue 6000/1.

Most frequent questions:

Can I take a bearing with a larger clearance class?

In general applications such as fans and in most papermaking applications, it is possible to take a bearing with a greater clearance class, without any significant influence on bearing service life or the operating conditions of the machine. It is anyway better to have a machine running with a bearing that doesn't have the right clearance class than having a machine at standstill.

Be careful to use the normally recommended clearance class at the next bearing change. Many mechanics choose a replacement bearing based on the designation of the dismantled bearing. If they have twice used a bearing with a greater clearance, the machine can run with a C4 bearing rather than the CN bearing it is supposed to have.

With a CARB toroidal roller bearing, a simple method, if it is possible on the machine, is to create a determined axial offset of the rings to reduce the internal clearance

Can I take a bearing with a smaller clearance class?

No, it isn't recommended, without technical study, to replace a bearing with another with a smaller clearance class due to the risk of excessive preload during operation.

One solution is to increase the clearance of the available bearing by reducing the raceway(s) diameter of the inner ring. Depending on where and how it is done, the bearing performance (friction, running accuracy, fatigue life) can be decreased and be far from original SKF design parameters.

Is the running accuracy of a C3 bearing better than the one of a C4 bearing?

Running accuracy doesn't depend on the clearance class.

SKF standards 22320 E, 22320 E/C3 and 22320 E/C4 have all a P5 running accuracy (four times better than ISO normal running accuracy class). But, as indicated on **page 3**, the residual operating clearance can have an influence on the overall running accuracy

It is also important to understand that a C4 bearing can operate with less residual operating internal clearance than a C3 bearing. It depends on the operating conditions and the way the bearing was mounted.

A bearing with a radial clearance near the maximum value of the C3 class, mounted with a very light fit can have a radial clearance, after mounting, with a bigger residual clearance than a C4 bearing, which clearance is close to the minimum value of the C4 class mounted with a very tight fit.

- 22320 EK/C3: the radial clearance is between 0,110 and 0,140 mm
- 22320 EK/C4: the radial clearance is between 0,140 and 0,180 mm

Let's take a 22320 EK/C3 having 0,135 mm radial clearance and a 22320 EK/C4 having 0,145 mm radial clearance. The recommended clearance reduction is between 0,045 and 0,060 mm.

- If the 22320 EK/C3 has a 0,045 mm clearance reduction the residual clearance after mounting is equal to 0,090 mm.
- If the 22320 EK/C4 has a 0,060 mm clearance reduction the residual clearance after mounting is equal to 0,085 mm.

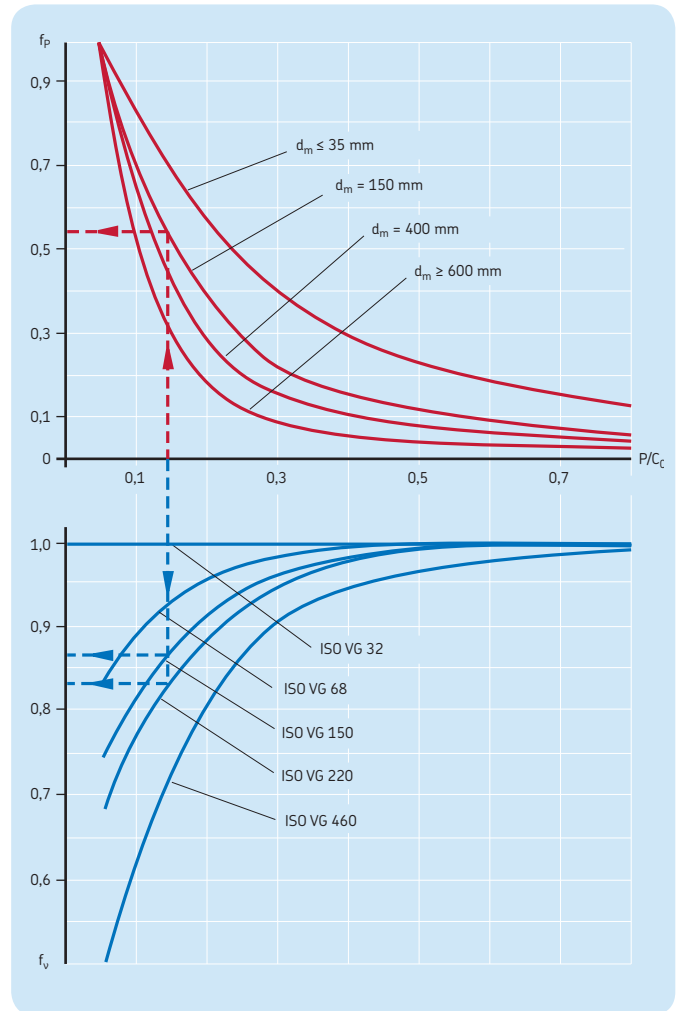

Diagram 3. Adjustment factors f_p and f_v for radial roller bearings.

Of course this doesn't happen very often and, statistically, C3 bearings have less residual clearance after mounting than C4 bearings. The demonstration was just to show that it wasn't true 100% of the time.

The bearing list in the storehouse shows that I need 22320 EK and 22320 EK/C3. Can I just store the C3 variant?

The answer is why not? In some cases, especially for low to medium loaded bearings, the increase of clearance from CN to C3 has only a small effect on service life and running accuracy or is within acceptable limits. The decision has to be taken case by case. There is no general rule.

Does lubrication influence the choice of the clearance class?

The answer is yes since depending on lubricant (grease or oil, viscosity), and quantity of lubricant, the bearing temperature will be different and the temperature difference between the inner ring and the outer ring will be different.

So, changing from oil bath to grease lubrication due to unwanted oil leaks can be risky. The SKF General Catalogue gives enough information for most of the cases.

My machine vibrates too much, should I take a bearing with less clearance?

The clearance is rarely the cause of the vibrations. Mounting a bearing with a smaller clearance doesn't take away the cause. The cause of the vibrations should be investigated. Then, when the cause is well understood, corrective actions can be taken.

In addition, mounting a bearing with a smaller clearance can be risky and create premature failure due to excessive preload.

Conclusion

I hope that this article gives a better view of what clearance class is and its influence on operating conditions. Choosing the adequate clearance class for a bearing isn't always straightforward since it depends on several parameters like shaft and housing fits, speed and lubrication. In a future article we will look at these things in more depth. In the meantime, in all cases, SKF can support you.

Philippe Gachet is an SKF application engineer who has been working with the heavy industries, particularly pulp and paper, since 1990. He can be contacted at philippe.gachet@skf.com



The case of the split inner race

In a mill in New England during the early eighties, the printing & writing paper machine had just "crashed". When the Engineering & Maintenance manager, Sam, arrived on the scene it had become obvious that at least one backside dryer bearing had failed and several drive gears had sheared teeth. The situation was, in a word, messy.

The immediate problem was to get the machine back in operation as soon as possible, so a plan was developed to begin round-the-clock repairs until the job was completed. Some forty-two hours later the machine started up and ran successfully. That was only part of the story, now came the problem solving session.

The "Upteam", a group of individuals assigned the task of solving problems that had occurred but should not reoccur within their respective operating areas, began their preliminary evaluation of the events surrounding the incident. The "Upteam" is a rudimentary, multi-faceted area operating team with one objective, eliminate re-occurring lost time incidents.

Generally the team "leader" is the Operating Manager (Ted, in this case) for the department. If not, the team leader must have that level of authority and decision-making. The team "facilitator" is the Maintenance or Reliability Engineer for the particular operating area. Generally a Maintenance Planner (Hank) and the area Maintenance Foreman (Bob) are also members.

Engineering effort is represented by the Area Engineer (Terry). Other departments, such as Purchasing and Personnel are asked to attend as required, for example if a supplier or training issue is involved. In this particular meeting, Sam was also in attendance.

The Maintenance Engineer (Jim) had gathered as much factual data as was available and proceeded to pass that information out to the other team leaders. This information is displayed in a simple tabulation. The basic questions asked are What, When, Where, Why, Who and How. The essential question though, after a cause is determined, is "What can be done to prevent this from reoccurring?"

It was determined that the failure of #10 backside dryer bearing had occurred just a few minutes after the machine had started up following a planned maintenance and machine clothing shutdown. The dryer bearing had failed completely. Pieces, becoming debris in the drive gear train, caused teeth on these gears to fail.

The dryer bearing had been lubricated, as evidenced by the oil still flowing. The rollers and outer ring were so destroyed that any attempt to use them for evaluation was fruitless, however the inner race was still attached to the dryer journal, after the failure.

The inner race showed evidence of overheating, and, more importantly, had a crack across the race. This was the key clue to the failure mode experienced.

Jim contacted the bearing manufacturer and after discussions with one of their applications engineers learned that this crack was strong evidence of thermal fatigue leading to failure.

Jim reasoned, with help from the bearing manufacturer's engineer, that the bearing had experienced severe overheating just prior to failure. One piece of data was the record of bearing "noise" (vibration) taken just prior to the shutdown. This was standard operating procedure for each machine scheduled shutdown. That particular bearing and the gear train near it were not suspected of any problems based upon the "good" readings taken at the time.

This was the data presented at the "Upteam" meeting. The discussion that followed was guided by Ted.

"Where would the overheating have come from?" Ted asked, addressing no one, and everyone, in particular.

"Well," volunteered Bob, "if there wasn't any oil in the bearing the metal surfaces rubbing together will generate plenty of heat, in a hurry."

"Was there oil to the bearing?" Ted asked.

"Yes" Bob replied, "in fact, we could still get oil flow to the bearing after the failure."

"Is oil supply a problem then?" asked an irritated Ted.

"Could be, sometimes," Bob answered.

"How do we make sure the oil supply is working?" Ted asked, directing his stare at Bob.

"First, the oiler for the machine," Bob replied.

"Was he looking after the oil system?"

"Always does, and was this time, as far as I know."

"What can be done to be absolutely sure that the oil supply is flowing, to all the bearings." Ted asked.

"I guess some type of flow indication or alarms, or something, although I don't think that is the problem." Bob responded.

Sam jumped in to the discussion, "Don't get sensitive, this is not a witch hunt or even a finger pointing session. We are here to find the cause, a solution, and prevent this from happening again. We are not going to waste our time by pointing fingers, making accusations or covering ourselves. Clear?"

"Yes." Bob responded, Others nodded their heads too.

"Okay, so if we could alarm the loss of oil flow we could have indication of that particular cause and eliminate failure, right?" After general agreement by nodding of heads, Ted continued, "Jim, make a note of that to assign follow up, I want Terry to follow this through and see what is available for alarming."

He was looking at Jim who was responsible for recording and follow-up with others from the group who would be assigned tasks.

"What is the normal start-up procedure for this machine?" he asked the attending Machine Foreman.

"Well, we start rotating the dryers as soon as we get the all clear from our crews and the maintenance crews. Usually that means as soon as all the locks are taken off the turbine".

"Then what?" continued Ted.

"We open the steam valves to the dryer steam supply to get the dryers warmed up." answered the machine Foreman.

"I think that's part of the problem," chimed in Bob.

"Why is that?" Ted asked.

"Well, the oil is not really warmed up before the steam is put on the dryers. It might only be 80 or 90 °F [26–32 °C] and it's thick, like molasses until its warmed up to operating temperature. That's the biggest part of the oilers job during start-up, going around adjusting flows until the oil and the piping is heated up and the oil flow settles down. In fact it is a real pain for the oilers."

"What else?" queried Ted.

"When the steam is put into the dryers, it's hot, and the steam is piped right through the bore of the backside journal," answered Bob, "All that heat, all at once, without cooling has got to cause some type of problem."

What temperature is the steam at this point?" Ted asked darting his eyes around the table.

Terry said, "I guess it could be 300 °F [149 °C], and it's probably superheated because we don't cool until after we get enough condensate back from the dryers to operate the coolers."

"You mean to tell me that we heat the metal up to some 300 °F and then subject it to cold oil of 80 to 90 °F during start-up?"

"Not every time," suggested Terry, "only after long shutdowns like this one, where the oil supply is shut off and the steel has cooled down to room temperature, or so. Normally, depending upon what work we are doing on the machine, we leave the oil system running and the metal doesn't cool down as fast."

"What about the oil temperature?"

"Well, the heater for the oil is steam coils and when the turbine is down so is the steam supply for the heater. We have had to make some changes in the heating system because it takes a lot of maintenance." Bob responded.

"So, let me get this straight, first we don't heat the oil when the machine is down when the oil needs heating. Then we turn on superheated steam to the dryers before the oil can be used for cooling and, of course, lubrication. Then the oiler has to scurry around trying to maintain some type of oil flow, without flooding the bearing housings, while the machine is warming up. Then, finally, after a couple of hours, the oil is heated to operating temperature? And we begin to cool the steam after we get enough condensate back from the dryers? Is that about right?" asked Ted, disbelief written all over his face to a general nodding of heads.

"Okay, so what do we do about this comedy of errors?" he asks.

"We could put insulating sleeves on all the backside journals to reduce the heat." Terry suggests.

"How much and how long will that take?"

"A lot of money and a lot of time. Each dryer would have to be re-fitted, I guess that would be out of the question."

"Next suggestion?"

"We could put in electric heaters in the oil system reservoir to maintain operating temperature even when we're down."

"How much and how long will that take?"

"Shouldn't cost too much, a few thousand dollars, don't know about installation time, would have to drain the tank. I'll look into that." ventured Terry.

"Good, make a note Jim, and I want a follow-up by the end of the month." stated Ted. "What else?"

"You know," Sam started, "at one other place I worked we had warm up loops on the oil circulating system to allow the oil to circulate in the headers prior to startup. It helped the oil flow during the startup, it kept a lot of the piping warmed up so there wasn't so much scurrying around by the oilers during start-up. Maybe we could look at doing something like that on this machine? It only takes a small change in the piping, connections and valves between the pressure header and the drain line."

"Are you volunteering?" asked the Uptime leader.

"Sure, I'll ask a few questions and put together an estimate for the next meeting." Sam responded.

"Good, any other suggestions?"

"This superheated steam problem should be easy to solve," suggested Terry, "we could either save enough condensate for startup instead of dumping it or we could bring some demineralized water over from the steam plant for cooling. It's not that far away, I'll look into it."

"Great, now we're clicking."

"I guess we could take a look at our startup procedure," said the Machine Foreman, "we could check with the oiler to see if he's ready before we just crank up the steam. I'll make those changes in our procedure."

"Anything else?" asked the Uptime leader. No response.

"Then let's plan to meet again on Wednesday, the 23rd, at 13:00 hours, right here. Okay? Be ready to give your report on your part of the solution."

This problem-solving process may not seem like such a big deal, but it was to this mill. They now had a system for dealing with downtime and production losses that involved more than one point of view, and more than one person thinking about a particular problem. A simple process that develops a plan and follows up on each element of that plan. What more could a Mill Manager expect?

Solutions take time, but the important aspect of this procedure is follow up. The Maintenance Engineer is the facilitator, the scheduler, the person responsible for making sure that ideas and tasks are followed. Of course he has support from the Team Leader and the team members.

The key is successful elimination of a recurring problem. One problem eliminated is reward for continuing the process another time.

John Yolton is approaching his 46th year in the industry. A many-journeyed, seasoned veteran of pulp and paper manufacturing, Yolton currently assists global paper industry clients with asset reliability improvement strategies. He can be contacted at john.yolton@skf.com.

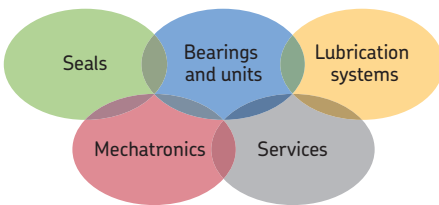

The Power of Knowledge Engineering

Drawing on five areas of competence and application-specific expertise amassed over more than 100 years, SKF brings innovative solutions to OEMs and production facilities in every major industry worldwide. These five competence areas include bearings and units, seals, lubrication systems, mechatronics (combining mechanics and electronics into intelligent systems), and a wide range of services, from 3-D computer modelling to advanced condition monitoring and reliability and asset management systems. A global presence provides SKF customers uniform quality standards and worldwide product availability.

SKF Global Pulp & Paper Segment

Contact/Responsible editor
philippe.gachet@skf.com

© SKF, CARB and SensorMount are registered trademarks of the SKF Group.

© SKF Group 2011

The contents of this publication are the copyright of the publisher and may not be reproduced (even extracts) unless prior written permission is granted. Every care has been taken to ensure the accuracy of the information contained in this publication but no liability can be accepted for any loss or damage whether direct, indirect or consequential arising out of the use of the information contained herein.

PUB 72/S9 11147/1 EN · June 2011





Mounting CARB toroidal roller bearing on a Yankee cylinder using the SKF Drive-up method

The importance of proper mounting and stores management

In my experience of working with mills all over the world I've seen a lot of problems caused by poor bearing mounting. As getting it right is so important, I'm sure that this issue of SKF Pulp & Paper Practices covering simple, fast and accurate modern mounting methods should be interesting for many of our readers.

Mounting, of course, is not the only thing we need to get right if we want our bearings to reach their service life potential. An appropriate bearing for the job needs to be selected in the first place and once mounted, it needs to be properly lubricated and monitored.

Mounting and lubricating bearings in the right way is crucial for the reliability of machines. Until now we assumed that the bearings and lubricants that are used are in good condition. Unfortunately, some bearings never even make it to the mounting stage. Often this

is because they get damaged while they are in mill stores. This happens more frequently than you might think and can lead to significant inconvenience and expense. Even worse is when the bearings or lubricants have "hidden failures" and we only find out about them after installation. To help our readers avoid this, I'm writing an article on bearing and lubricant storage that will appear in the next issue of this newsletter.

Regards,
Rene van den Heuvel
Maintenance Solutions Manager
Pulp & Paper, SKF
rene.van.den.heuvel@skf.com



SKF Drive-up method and SensorMount

In the first issue of SKF Pulp & Paper Practices we saw that the most common method to get the correct tight fit of the bearing on its seat, the radial clearance reduction method with feeler gauges, takes time and can lead to inadequate fits. The method is time consuming because the operator must put the rollers in their equilibrium position and measure the clearance several times while the bearing is driven up its taper seat. It can lead to inadequate fits because the method relies on the technician's "feeling".

There are other old mounting methods like measuring the axial drive-up but, regardless of how the drive-up is controlled, they always face one major issue i.e. the axial drive-up starting position. I learnt to find the starting position by hitting the nut spanner with a hammer. When there was a true interference fit, the sound became more metallic. For bearings mounted on a taper seat, we can also push the bearing with enough force along its seat that it bangs against it. Here, again, the starting position was dependent on the sound.

Another issue was how to control the drive-up if a hydraulic nut was used to push the bearing along the taper. It could sometimes be difficult to measure bearing inner ring axial displacement along its seat. If we could use another method, like the feeler gauge method, we would never mount a bearing on its taper seat by controlling the axial drive-up.

In some cases a feeler gauge couldn't be used because the bearing had a low section height, was partly hidden by the hydraulic nut and was mounted in a blind housing. The only option was to control the axial drive-up. Several makeshift solutions were used like welding a metal strip on the hydraulic nut piston. A dial gauge on a magnetic support would give the piston displacement and thus the inner ring axial displacement.

To know if the drive-up was correct without knowing the starting position, the only way was to measure the bearing's radial clearance before placing the hydraulic nut. Then the bearing was driven up its seat to around half or less of the desired axial drive-up. Subsequently, the hydraulic nut was removed to be able to measure the radial clearance again. Knowing the clearance reduction obtained, it was easy to know how much more drive-up was necessary to have the correct tight fit.

Example:

According to the SKF General Catalogue, a 23080 CACK/W33 has a reduction of radial clearance range from 0,170 to 0,230 mm. That corresponds to an axial drive-up of between 2,6 and 3,6 mm. The bearing has a radial clearance of 0,400 mm before drive-up and we want 0,200 mm clearance reduction. That means that we want $0,200 \times 3,6 / 0,230 = 3,13$ mm drive-up.

Put the bearing on its taper seat, check the radial clearance, screw tight the hydraulic nut and pump oil into the nut while controlling the axial drive-up. **Fig. 1** shows a case where the axial displacement of the adapter sleeve under the bearing is followed. After 1,5 mm axial drive-up, the nut is dismantled and clearance checked: 0,050 mm clearance reduction instead of $1,5 \times 0,230 / 3,6 = 0,095$ mm estimated. It means that the real starting point, where the inner ring start to expand was further away than expected. There is now $3,6 (0,200 - 0,050) / 0,230 = 2,35$ mm more axial drive-up needed for the desired clearance reduction.

Tired of such old, imprecise and time-consuming methods?

Well, SKF can help and once you have started to use a modern method, we're sure you won't want to change back. Even those who have used the old methods all their life, and who swear by them, change their mind after having tested the modern methods. There are two of these: the SKF Drive-up method and SensorMount.

Let's start with the easiest, fastest and most modern: SensorMount

Fig. 1 Axial displacement of the adapter sleeve



SensorMount

The bearing, large size ones only for the moment, is equipped with a sensor on the inner ring. This is connected to a handheld device which indicates a value which correlates with the interference fit.

After having checked and oiled the mating surfaces, simply:

- 1 Put the bearing on its seat
- 2 Screw the hydraulic nut against the bearing
- 3 Connect the sensor to the handheld device
- 4 Connect the hydraulic nut to a hydraulic pump
- 5 Switch on the device and zero the display

The displayed value is equal to the internal clearance reduction in mm divided by the bearing bore in meters (→ fig. 2).

Example of a ZE 24184 ECACK30/C3W33 bearing mounted on a press roll for which you want a clearance reduction of 0,210 mm. The bearing diameter is 0,420 m. So, the correct interference fit is obtained when the display indicates **0,50** ($= 0,210 / 0,420$). Pretty easy so far, isn't it?

Drive the bearing up along its seat until the handheld device indicates 0,50 and wait 15 to 20 minutes before releasing the oil pressure in the hydraulic nut. After that, cut the sensor wire, replace the hydraulic nut with a lock nut and that's all. Yes, really, that's all.

This method isn't influenced by:

- the operator's experience and feeling
- bearing size
- shaft design (hollow shaft or not)
- conditions of the mating surfaces (roughness / slight fretting corrosion etc.) and their lubrication

No calculations are needed, except in special cases. We recommend 0,50 as the final displayed value.

The following **figs. 3 to 7** show the SensorMount being used to mount bearings on solid press rolls at a Metso facility in Finland.

Fig. 2 SensorMount. Note that injecting oil between bearing and shaft is not compulsory.

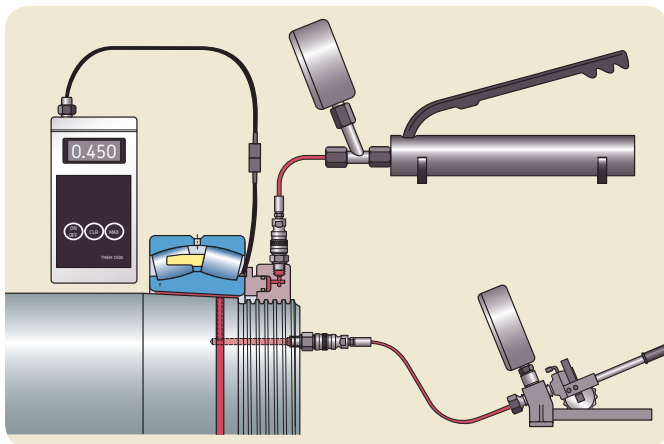

Fig. 3 Eerikki Makinen, SKF Finland's application engineering manager, explaining the CARB toroidal roller bearing mounting procedure with SensorMount



Fig. 4 The handheld device shows 0,420 and the Metso's technician gets ready to switch off the air drive oil pump connected to the HMV hydraulic nut.

Fig. 5 0.500, the correct interference fit is obtained and the air driven oil pump is switched off.





Fig. 6 On the other side, the spherical roller bearing is also equipped to be mounted with SensorMount.



Fig. 7 A Metso technician cuts off the sensor cable.

Note that SensorMount bearings have either the prefix ZE (e.g. ZE 24184 ECAK30/C3W33) or ZEB (e.g. ZEB 24184 ECAK30/C3W33).

With the ZE version, the sensor is positioned on the smaller bore diameter side. **Figs. 3 to 7** show ZE bearings mounted directly on a tapered journal. The sensor is on the hydraulic nut side, not the press roll side. If the same bearing was mounted on a withdrawal sleeve, the bearing smaller bore diameter side plus the sensor, would have been on the press roll side and thus not really accessible. Bearings with prefix ZEB have the sensor positioned on the larger bore diameter side.

There are a couple of additional things worth noting about SensorMount. Firstly, that sensors and cables can be replaced, or added, if the dismantled bearings are sent to an SKF remanufacturing centre. Secondly, that the hand-held device (SKF Tmem 1500) isn't supplied with the bearings.

As only large bearings (contact SKF for sizes) can be supplied with a sensor, I have now to write about the SKF Drive-up method which

is suitable for all CARB toroidal roller bearings, spherical roller bearings and self-aligning ball bearing with bore diameters equal or greater than 50 mm.

SKF Drive-up method

Please do not be scared by my explanations of the SKF Drive-up method. It's simple. Well, it isn't as simple as using SensorMount, but it's much faster and reliable than the feeler gauge method.

Knowing how the bearing is mounted, the bearing designation, the shaft design (bore and material) and the hydraulic nut size will allow you to obtain two values from the drive-up software or table. One value is a pressure, the other is a distance. For example, for a 24184 ECAK30/C3W33 mounted on a press roll on a tapered plain steel journal, the values would be 3,62 MPa and 6,24 mm.

To mount this bearing:

- 1 Oil the bearing seat
- 2 Place the bearing on its seat
- 3 Screw the hydraulic nut in place against the bearing

Fig. 8 A CARB toroidal roller bearing, mounted with the SKF Drive-up method, on a Yankee cylinder at Delipapier, France in 1999. The SKF engineer controls the axial bearing displacement indicated by the dial gauge that can be seen in fig. 9.



Fig. 9 The dial gauge hidden by the journal shown in fig. 8

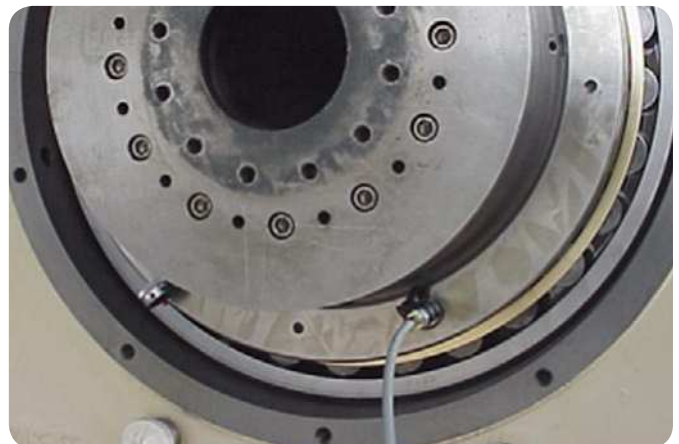

- 4 Connect the hydraulic nut to a hydraulic pump and pump until the pressure gauge indicates 3,62 MPa.
- 5 Then place a dial gauge in the hydraulic nut. It will follow the nut's piston, thus the bearing axial displacement
- 6 Pump oil in the hydraulic nut until the dial gauge indicates that the piston has moved 6,24 mm. Do not release oil pressure in the nut for the moment
- 7 Now the most important thing is to take your coffee break or if you have old fashioned colleagues mounting another bearing not far away and trying to follow internal clearance reduction with a feeler gauge, tease them! After that, you can release oil pressure from the nut.

That's it. You have finished and you can do something else while your colleagues are still playing with their feeler gauge.

It's simple and easy. Most of those who use the drive-up method for the first time are suspicious and do final radial clearances checks with feeler gauges even though it is not needed.

Oil pressure and drive-up displacements are given in tables that are in various SKF documents, but we recommend the use of the on-line software at www.skf.com/mount/ which is continuously updated or the SKF Drive-up method software on CD.

To proceed following the SKF Drive-up method, there is a need for the following equipment (→ **figs. 10 and 11**):

- 1 a hydraulic nut
- 2 a hydraulic pump
- 3 a pressure gauge appropriate for the mounting conditions
- 4 a bearing axial displacement measuring device. SKF recommends a dial gauge that follows the hydraulic nut piston displacement.

The idea is to measure the axial displacement of the bearing along its tapered seat in an accurate way. The main difficulty with the old

methods was to find the starting position. The SKF Drive-up method gives a reliable starting position.

Those who change the cylinder head gasket on car engines using the angle tightening method for the cylinder head bolts will quickly see the similarity. The bolt angle tightening method is much more precise than full tightening with a torque wrench, but needs pre-tightening to remove all clearance. This pre-tightening is done with a torque wrench and is, in general, between 10% and 40%, of the torque needed to obtain the correct tightening. The pre-tightening gives the starting point from which the angle displacement of the bolt head (or the nut) is undertaken. The philosophy of the SKF Drive-up method is similar since pre-tightening is done to find the starting point of the final axial displacement. The pre-tightening is here a slight interference fit of the bearing on its seat due to a pre-axial displacement under a predetermined axial load. Above this initial interference fit, reduction in the radial internal clearance may be regarded as being directly proportional to the axial drive-up. The SKF Drive-up method isn't new, we've been using it for 20 years.

Using a torque wrench (torque on the bearing lock nut) to get the starting position isn't the best solution for two reasons:

- 1 Axial load, that pushes the bearing along its taper seat, will depend too much on the good conditions of the contact between the lock nut's threads and the face in contact with the bearing plus the friction in these contact surfaces. If the axial load is created by a hydraulic nut, all this can be forgotten and axial load will depend directly on the hydraulic nut size and oil pressure.
- 2 Why waste time trying to measure torque, especially on big lock nuts, when the axial load can be revealed by measuring the pressure of the oil injected in the hydraulic nut that that will be used to push the bearing for the final drive-up? I know some who still use a huge hammer on innocent lock nuts to drive-up big bearings, but that's another story.

The starting position in the SKF Drive-up method is given by the oil pressure of the oil injected into a SKF HMV hydraulic nut. The oil pressure is quite low, a few MPa, so a very accurate pressure gauge is needed. I recommend, of course, the SKF TMJG 100D digital gauge.

Fig. 10 Tools needed for the SKF Drive-up method

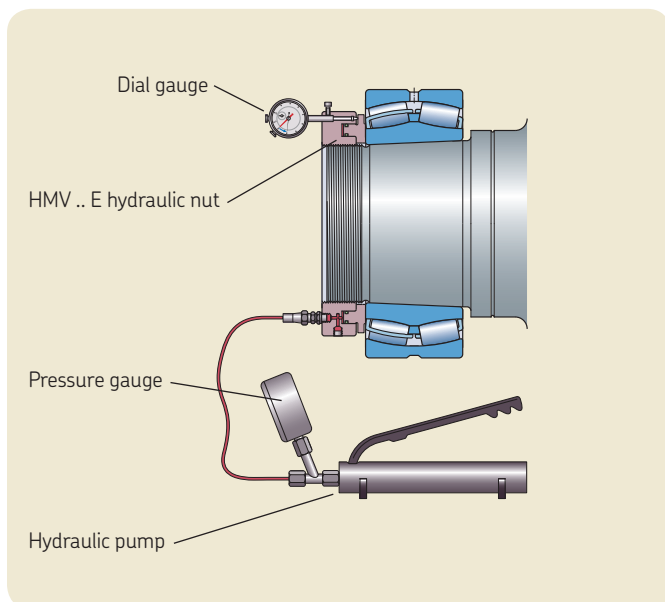

Fig. 11 Tools needed for the SKF Drive-up method



The starting position will give a high enough interference fit to be sure that there is intimate contact between the bearing and its seat, but not too much interference fit so that any starting point deviation will have a negligible influence on the final interference fit. With the SKF Drive-up method recommendations, the starting position corresponds to around 20% of the final interference fit if the default value of recommended drive-up is chosen. It can be near 10% for bearings mounted with a very tight fit.

The interference fit at the starting position depends on:

- 1 The sliding friction in the contact surface (bearing/shaft, bearing/sleeve and/or sleeve /shaft). If there is too much friction, for the same oil pressure in the hydraulic nut the bearing will have too low axial pre-displacement. Too low friction means too much axial pre-displacement.
- 2 The bearing inner ring thickness. The thicker the inner ring, the more resistance to drive there will be. So, for same oil pressure in the hydraulic nut, the bearing will have less axial pre-displacement.

- 3 Conicity of the tapered seat. Either 1/12 either 1/30.
- 4 Number of sliding surfaces.
- 5 Circularity and straightness error forms.

For point one, sliding friction depends on surface conditions and their lubrication. If necessary, clean the surfaces with sand paper to remove bumps. Always lubricate the sliding surfaces, but never inject oil in the mating surface while the bearing is driven up to its starting position.

Points two and three above depend on the bearing designation. This means that pressure values given by SKF software or tables are only valid for SKF bearings.

Concerning point four, in general there are either

- one sliding surface (→ **figs. 12 and 13**)
- two sliding surfaces (→ **figs. 14 and 15**)

The number of sliding surfaces will influence the oil pressure needed to get to the starting position.

Fig. 12 Bearing mounted directly on tapered shaft

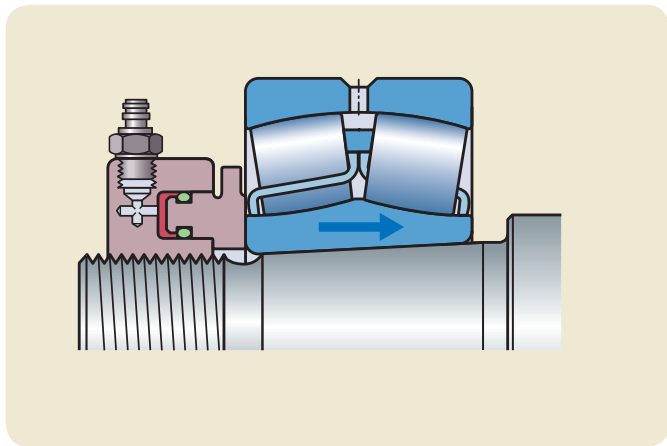

Fig. 13 Bearing mounted on a adapter sleeve and pushed

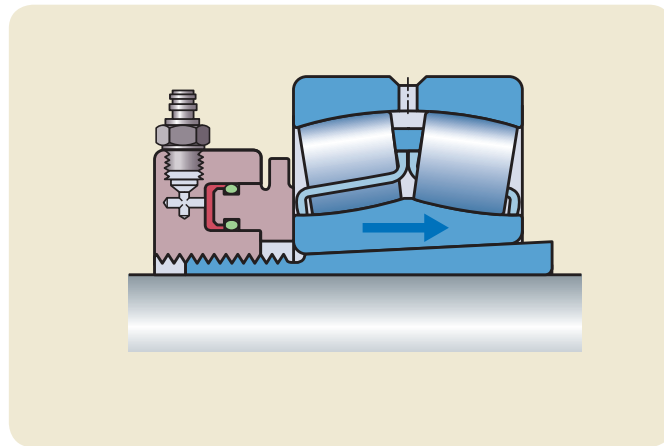

Fig. 14 Bearing mounted on an adapter sleeve which is pulled and slides between bearing and shaft

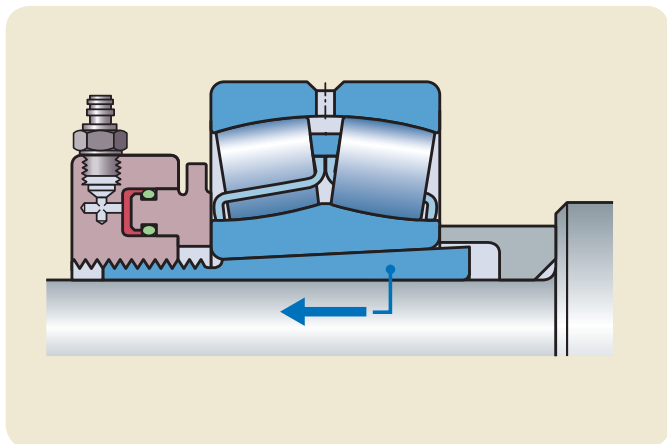
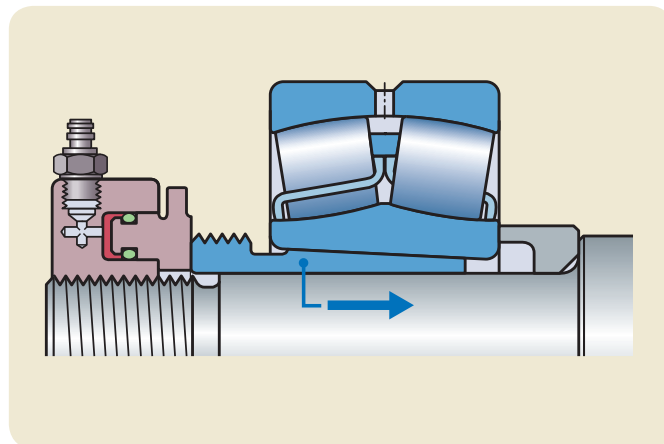

Fig. 15 Bearing mounted on a withdrawal sleeve which is pushed between bearing and shaft.



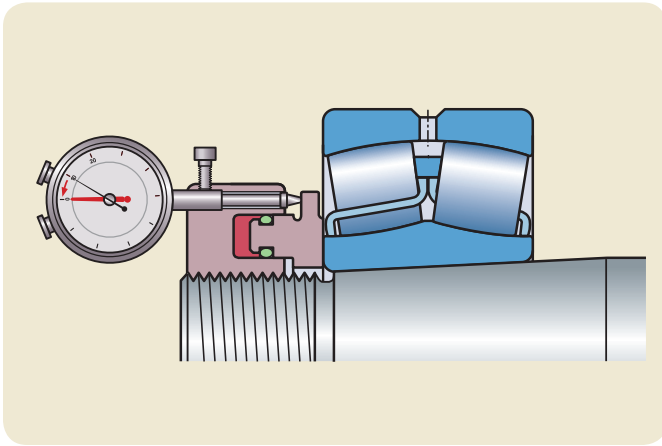

Fig. 16 The dial gauge follows the axial displacement of the hydraulic nut piston, thus the inner ring displacement

Example: for a drying cylinder bearing 23152 CCK/C4W33 we need, with the same hydraulic nut size, 2,9 MPa when it is mounted on a tapered journal and 4,9 MPa when it is mounted on an adapter sleeve.

During the drive-up to reach the starting position, look at the oil pressure and don't bother about the axial displacement.

Once the starting position is reached, it's time to fit the dial gauge to follow the bearing inner ring drive-up.

SKF proposes hydraulic nuts in which a dial gauge is placed in a hole to follow the piston displacement (→ **fig. 16**). These hydraulic nuts, standard for about 15 years, have the suffix "E".

SKF HMV 48 is an old size 48 hydraulic nut without the hole and piston design for the dial gauge.

SKF HMV 48 E is a size 48 hydraulic nut designed for the SKF Drive-up method.

Choose a good quality dial gauge and check that it can follow the nut piston for the total distance of the drive-up. Some dial gauges might need an extension rod.

If you have an old hydraulic nut, either you place the dial gauge as shown in **fig. 1** or like in **fig. 17** or you mount an SKF adapter HMVA 42/200 for nuts from size 42 to 200 (→ **fig. 18**). For practical reasons, I would recommend the use of a hydraulic nut designed for the SKF Drive-up method.

Final axial drive-up will depend on

- 1 The desired interference fit. To make it easy, as most people think "clearance reduction", the software allows you to enter a clearance reduction. By default, software and many tables give a clearance reduction equal to 0,45% of the bearing bore diameter. The value is like the one used for SensorMount. For the pulp and paper industry, we recommend 0,50 instead of 0,45 (see important notes at the end of this article). The value can be even higher than 0,50 in some cases.
- 2 Bearing design features such as the inner ring thickness. What's valid for SKF bearings might not be valid for other brands.
- 3 Shaft design. Very large bore diameters need higher axial drive-up to get the correct interference fit. Be careful! Most tables give the drive-up value for solid plain shafts.
- 4 Interference reduction due to smoothing. If the bearing has been mounted several times and/or the bearing seat is slightly worn, the interference reduction due to smoothing is lower. The influence of the smoothing is so small that it can be ignored for large bearings.
- 5 Shaft material characteristics. Be careful! Most tables give drive-up values for steel shafts.

Once the dial gauge is in position and the axial drive-up value is known, pump oil into the hydraulic nut and at the same time control

Fig. 17 Dial gauge following inner ring displacement. The dial gauge is supported by a magnetic support fixed on the journal



Fig. 18 SKF adapter HMVA 42/200



the dial gauge. Follow the axial drive-up on the dial gauge and do not bother about the oil pressure.

Be aware that after the drive-up is finished and the coffee break taken, when you release the oil pressure from the hydraulic nut, the needle of the dial gauge will move backwards. It isn't the bearing that has moved down its seat. It is the nut's piston that has moved due to the fact that the piston's seals were elastically deformed during the bearing drive-up.

Let's recap with an example of how I use the SKF Drive-up method

A CARB C3152 K/C4 is to be mounted on a drying cylinder. The journal is made of steel and has a 130 mm bore diameter. The taper seat is directly on the journal and the lock nut and thus the hydraulic nut should be size 52, just like the bearing.

I use the SKF Drive-up method CD to find the starting position oil pressure and axial drive-up displacement after the starting position. I replace the 0,45% default value by 0,50%. **Fig. 19** shows a screen print.

The software enables me to print the inputs and the results which are 2,76 MPa and 1,679 mm. In addition, the print gives information about suitable tools and the mounting procedure (→ **fig. 20**).

On site, I check the bearing seat conditions and oil it. I might, if I have time, check the bearing/seat contact with Prussian blue before oiling it.

Then, having placed the bearing on its seat ready for drive-up, I screw the HMV 52 E hydraulic nut against the bearing and connect it to the SKF 729124 SRB hydraulic pump equipped with an accurate pressure gauge.

I place the two rings of the CARB toroidal roller bearing, without any axial offset. Offset measured by eye as there is no need to be precise. The reason for this is to avoid internal bearing preload during drive-up. Then I will pump until the oil pressure stabilises at 2,76 Mpa.

Then it's time to put the dial gauge in the hydraulic nut taking care that the dial gauge needle will be able to follow the nut's piston at 2 mm (higher than 1,679 mm) axial displacement. Then I pump, taking care that the needle moves with ease, until it has moved to a distance between 1,67 and 1,69 mm.

After the dial gauge indicates the requested axial displacement, I leave it for 10 minutes. There's no need for more as it isn't a very big bearing. Then, the oil pressure in the hydraulic nut will be released and the hydraulic nut replaced by the lock nut.

Do you still want to use the inaccurate and time-consuming feeler gauge method?

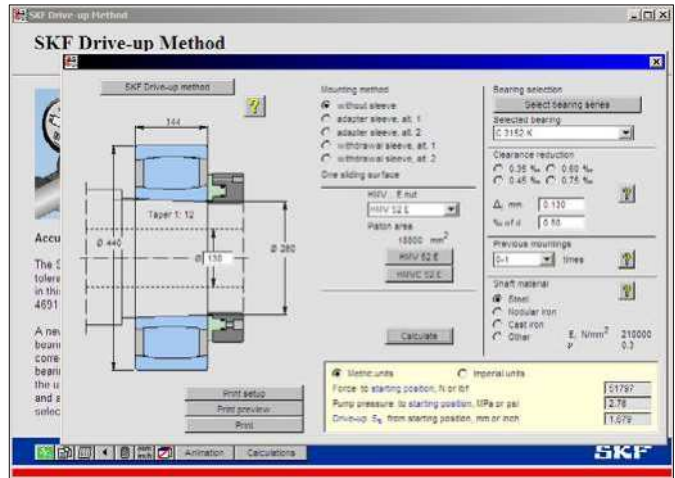

Fig. 19 Screen capture of the SKF Drive-up software

Fig. 20 Recap of the results of the software calculation

SKF Drive-up Date: 05/03/2011

Every care has been taken to ensure the accuracy of the information in this system but no liability can be accepted by SKF for any errors or omissions. NBI This method applies only for current generation SKF bearings.

Input	Bearing directly on shaft, one sliding surface	
Mounting	0-1 (of same bearing on the same shaft and sleeve)	
Number of previous mountings	0,130	
Required clearance reduction, mm	Steel E = 210000 N/mm ² v = 0.3	
Shaft material		

Results	
Force to starting position	51797 N 11645 lbf
Pump pressure to starting position using HMV 52 E	2.76 MPa 400 psi
Drive-up distance from starting position	1.679 mm 0.066 inch

SKF C 3152 K
(Basic designation)

Taper 1: 12

Ø 144 mm
Ø 130 mm
Ø 260 mm

Designation: HMV 52 E (metric thread)
HMVC 52 E (inch thread)

Mass, kg 19.0 lb 41.90
Permitted piston displacement, mm 11 in 0.43
Piston area, mm² 18800 in² 29.14

Suitable tools	Mounting procedure
Hydraulic nut	1. Lightly oil all mating surfaces with a thin oil, e.g. SKF LHM 300.
Hydraulic pump with special pressure gauge	2. Drive the bearing up to the starting position by applying correct pump pressure or force.
Dial indicator	3. Drive the bearing up on the taper the required distance while measuring the axial movement of the HMV...E piston.

Complete bearing designation:

Machine no.:

Position:

Mounted by:

Date:

SKF Drive-up Method Version 3.2 © Copyright SKF, 2001

Additional important notes:

It is recommended to inject oil between the bearing and its seat during drive-up to reduce friction and avoid surface damages. For large bearings, if oil isn't injected in the sliding surfaces, the axial load that pushes the bearing can deform the hydraulic nut. The nut is wrenched backward and the axial displacement indicated on the dial gauge, located on the nut, will be higher than the real bearing displacement along its tapered seat. One part of the displacement shown is actual axial drive-up of the inner ring, but without oil injection between inner ring bore and shaft and/or sleeve, a large part of the displacement shown is simply hydraulic nut deflection. In cases with two sliding surfaces, it is also recommended to inject oil between the sleeve and shaft.

Do not inject oil in the mating surface during pre-displacement when the SKF Drive-up method is used, but only after the starting position.

The 0,45 default value is given to allow enough interference fit to avoid inner ring creep on the bearing seat and fretting corrosion in the mating surfaces and, at the same time, to give the lowest inner ring internal stress due to the tight fit. Bearing fatigue life is reduced when increasing the drive-up. The value is given for "normal" loads. As a simple guide line, I consider that maximum "normal" load is equal to 10% of the dynamic basic load rating (C_{dyn}) of the bearing. Note that inner ring creep and the fretting corrosion depend also on the clearance in the bearing. As noted in issue 2 of SKF Pulp & Paper Practices, the larger the clearance, the larger is the load on the most loaded roller and the larger is the risk of fretting corrosion and inner ring creep. **For the pulp and paper industry, we recommend to take 0,50 instead of 0,45.**

Higher interference fits and thus higher values, up to 0,90 in some rare cases, may be needed in cases of very high load and/or too high clearance and/or bearing seating with a very large bore and/or steep thermal gradients resulting from rapid start-ups.

The 0,45 default value gives a lower clearance reduction than what is normally recommended when the feeler gauge method is used. This is normal. One reason is that in the past, with the feeler gauge method, the lack of accuracy could lead to too low interference fit. So, it was accepted to recommend clearance reduction values giving higher interference fits than were really needed.

"Hydraulic" pump and "hydraulic" nut doesn't mean that any hydraulic oil is adequate. This is especially valid when injecting oil in the bearing/shaft (or sleeve) contact surface for dismounting purposes. Most hydraulic oils have too low viscosities. Use SKF LHM 300 oil, and for dismounting, use SKF LHDF 900.

Some have complained that using SensorMount has resulted in loose fits when the bearing was mounted, during a very short machine stop, on a hot journal. In fact, the old mounting methods take time and the bearing inner ring has more time to get close to the journal temperature before the end of the drive-up. Whatever the mounting method used, a correct tight fit is obtained when the bearing inner ring temperature is at the same temperature as the journal on which it is mounted. I recommend that, whatever is the mounting method used, the bearing should be heated up with an SKF TIH induction heater (with automatic demagnetization) to the shaft temperature. If the bearing is too big to use such a heater, it should be left on its seat to heat up and on the journal to cool down.

Philippe Gachet is an SKF application engineer who has been working with the heavy industries, particularly pulp and paper, since 1990. He can be contacted at philippe.gachet@skf.com



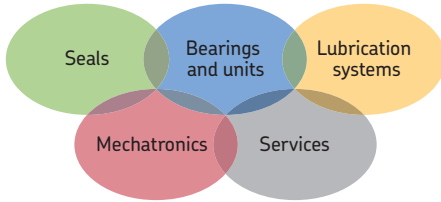

The Power of Knowledge Engineering

Drawing on five areas of competence and application-specific expertise amassed over more than 100 years, SKF brings innovative solutions to OEMs and production facilities in every major industry worldwide. These five competence areas include bearings and units, seals, lubrication systems, mechatronics (combining mechanics and electronics into intelligent systems), and a wide range of services, from 3-D computer modelling to advanced condition monitoring and reliability and asset management systems. A global presence provides SKF customers uniform quality standards and worldwide product availability.

SKF Global Pulp & Paper Segment

Contact/Responsible editor
philippe.gachet@skf.com

© SKF, CARB and SensorMount are registered trademarks of the SKF Group.

© SKF Group 2011

The contents of this publication are the copyright of the publisher and may not be reproduced (even extracts) unless prior written permission is granted. Every care has been taken to ensure the accuracy of the information contained in this publication but no liability can be accepted for any loss or damage whether direct, indirect or consequential arising out of the use of the information contained herein.

PUB 72/S9 11147/2 EN - August 2011





Spare rolls are often stored with the bearings mounted. When rolls are taken off the machine, bearings should be cleaned then re-lubricated or sprayed with preservative oil. More information can be found in the 'Roller bearings in paper machines' handbook (publication number 10580)

SKF self-aligning bearings and the pulp & paper industry

As SKF's product manager for self-aligning bearings, my job is to make sure that your needs are met by our products. As you can imagine, I get to talk to many customers from many different industries, but I particularly enjoy working with people from the pulp and paper industry because it has been a major driver of our product development over the years.

The relationship between SKF and the paper industry certainly has been a long and fruitful one. Your industry's need for faster and wider machines in the mid 1990s led us to develop the CARB toroidal roller bearing, for instance. More recently, we have developed and introduced a large range of sealed spherical roller bearings which are widely used on auxiliary equipment. Late 2011, we extended our range of SKF Explorer spherical roller bearings. We also introduced a new heat treatment for our spherical roller bearings, CARB and spherical roller thrust bearings which is more crack resistant and less sensitive to inadequate lubrication and contamination.

You can read more about this in an article in this issue of SKF Pulp & Paper Practices.

This issue also includes an article by our pulp & paper segment's maintenance solutions manager, stressing the need for proper bearing and lubricant stores practices. This is important because it's not enough to simply select good quality bearings. To get the most from them, you also need to make sure that they are properly stored, mounted, monitored and maintained as well.

Regards,
Johan Ander,
Product Manager,
self-aligning bearings & specialty products, SKF
johan.ander@skf.com



New heat treatment for improved performance

Before leaving you to read Rene's article about proper bearing and lubricant storage, I would like to quickly tackle two topics. Firstly, the new heat treatment used for the most important bearing types for the pulp and paper industry and, secondly, some changes in the clearance reduction table that we showed in the first issue of SKF Pulp & Paper Practices.

The new heat treatment

SKF has launched a new heat treatment for the steel used in all our standard CARB toroidal roller bearings, spherical roller and spherical roller thrust bearings. The resulting steel is more crack resistant and less sensitive to inadequate lubrication and solid contamination. We believe it's the next step towards better performance and reliability. Think of it as an upgrade to the well respected X-Bite steel that we previously used.

This is the latest of many such steps that SKF has made and often it was the needs of the paper industry that drove development. For example, we started making spherical roller bearings that were dimensionally stable to 200 °C (392 °F) in the 1950s. Most of these were made from bainite steel because martensitic steel was too prone to ring cracking in heated cylinder applications.

As time passed, steel got cleaner and the oxygen content decreased resulting in increased fatigue life. Nevertheless, in the 1990s we took another big step forward with X-Bite. This was a special bainite heat treatment which led to a harder steel that was also tougher and, therefore, less sensitive to cracks.

Field experience with spherical roller bearings made from bainite and then X-Bite steel on drying cylinders led us to change our general recommendations. We now recommend standard SKF bearings for all heated cylinders except where the steam temperature is above 170 °C (338 °F) and there is no journal insulation. For these unusual cases, we still recommend bearings with case hardened inner rings. Such SKF bearings have the suffix HA3 or the prefix ECB.

Since September 2011, new CARB toroidal roller bearings, spherical roller and spherical roller thrust bearings are made from the upgraded steel rather than X-Bite. The bearings and the boxes that they come in are marked "WR" for "Wear Resistant". This marking is important because there are new rule of thumb factors influencing rating life calculations with the upgraded steel. If a machine has been designed for "WR" bearings, mounting an older generation bearing could give a lower fatigue life than expected.

So, what will the upgraded steel do for pulp and paper industry customers? Well, there are a number of improvements actually of which the most significant are the higher toughness and the lower sensitivity to too thin oil films between the rollers and raceways.

Higher toughness

The new heat treatment results in a steel that is even harder to crack than X-Bite. Yes, the X-bite that we recommended for heated rolls and which was the through hardened steel with the highest toughness on the market. With this steel, we have taken another step to further increase the toughness and the hardness which results in a safer failure mode.

The pictures below show the test results of a spherical roller thrust bearing running under extreme conditions. Conditions chosen so that that the shoulder of the shaft washer (inner ring), made from X-Bite, would crack (→ **fig. 1**). With the same running conditions the shaft washer made from the upgraded steel didn't crack (→ **fig. 2**). Instead, spalling due to fatigue appeared.

Fig. 1 Bearing with cracked shaft washer



Fig. 2 Bearing made from upgraded steel with spalling



Less sensitive to inadequate lubrication

By inadequate lubrication, I mean too thin an oil film. This is a typical issue in heated cylinder applications when there is no insulation or when the insulation fails. In such situations, heat is transferred to the bearing, the operating temperature rises and the lubricant loses its viscosity. The oil film gets thinner, resulting in more metal to metal contact. This leads to either polishing wear (with its characteristic mirror-like raceways), micro spalling (also known as surface distress which leads to dull raceways) or, sometimes, smearing. All of these things, as you would expect, reduce bearing fatigue life.

The upgraded steel performs much better in conditions that could lead to polishing wear and/or micro spalling. This higher performance can be estimated using rule of thumb based correction factors in the rating life calculations. For more details, please contact your local SKF application engineering department.

Let's look at a 23152 CCK/C4W33 mounted on a drying cylinder by way of example. There's no insulation, the steam temperature is 160 °C (320 °F) and the oil flow (ISO VG 220) is nearly 3 l/min. The load on the bearing is 15 tons and the speed is 150 r/min. The filter is a Beta25=75 so, the filtration in this example isn't good. These operating conditions result in a bearing operating temperature of 120 °C (248 °F) and, per the SKF General Catalogue, a contamination factor of 0,15. In this example, the upgraded steel will have a significant impact since it is harder and, thus, less sensitive to indentations than X-Bite.

In the conditions listed above, with a thin oil film and poor filtration, the upgraded steel has a 35% higher rating life! Of course, I selected difficult operating conditions, but these are typical of an older machine pushed over its design speed with increased steam pressure, no journal insulation, unreliable water extraction from inside the cylinder and poor oil filtration. In cases where bearings run with a suitable oil film thickness and clean oil, the differences between X-Bite and upgraded steel will, of course, be small.

Don't forget that calculated rating life is not the same as service life since it doesn't account for poor storage, handling or mounting, contamination with process water and so on. Regardless of the steel grade and heat treatment, lubricating a bearing with process water will dramatically shorten its life.

Moving on, when there is surface distress due to inadequate lubrication there are numerous micro cracks in to which oil and water will be pressed by the load contact between rollers and raceways. And, we know that dissolved water has a negative influence on bearing service life. The upgraded steel is less sensitive to inadequate lubrication so, we can expect less and smaller micro cracks. Given this, dissolved water should have less influence on service life.

Changes in the clearance reduction and axial drive-up tables for spherical roller bearings and CARB toroidal roller bearings

The table showing the recommended value for reduction of radial clearance and axial drive-up (→ **page 7 in the first issue of the SKF Pulp & Paper Practices**) has recently been modified. These modified tables were first published in the SKF Bearing Maintenance Handbook (publication number 10001 EN).

The paragraphs concerning "permissible residual clearance after mounting" have been removed. This is a good thing as there will be less premature failures due to the fact that some people always want to reach the permissible residual clearance even if it gives too tight an interference fit. It is mainly because they were not understood that these residual clearance values have been taken away.



Note that the text replacing the values will not be the same as in the existing SKF Bearing Maintenance Handbook. What you should follow is the text that will appear in the new SKF General Catalogue, which is reproduced below (→ **table 1** and **2**). The SKF Bearing Maintenance Handbook will be updated at the next reprint to be in line with the new SKF General Catalogue.

As a guideline for pulp and paper applications, I recommend, unless otherwise specified by the machinery manufacturer or SKF, to use the lower half of the clearance reduction and to try to aim for the minimum value. For example, for a dryer cylinder bearing, 23152 CCK/C4W33, the clearance value is between 0,120 and 0,150 mm and you should aim for a clearance reduction of somewhere between 0,120 and 0,135 mm.

That said, I must admit that trying to reduce the clearance in small bearings with a feeler gauge isn't easy if you're trying to aim for the lower half of the clearance reduction range. With a 22314 EK felt roll bearing, for example, the clearance reduction is between 0,035 and 0,040 mm and achieving a clearance reduction just above 0,035 mm will be nearly impossible with a feeler gauge. You could easily be below 0,035 mm in reality. As such, for smaller bearings mounted using the feeler gauge method, it's better to use the full clearance reduction recommended range. Note that, with the exception of some large bearings, the maximum value of the recommended clearance reduction is lower than it was in the past.

Where possible, I recommend using the SKF Drive-up method as it is much more precise. If the bearing needs a higher clearance reduction value – near or above the maximum due to load, for example – the influence on internal clearance should be taken into account. In cases of any doubt, please contact your local SKF application engineering department.

Please note that the clearance reduction and axial drive-up values, which have been used for decades, have also changed. These have worked well over the years, and were copied by other bearing manufacturers, but:

- 1 The table wasn't consistent with the SKF Drive-up method that uses the real thickness of the rings. Bearing ring thickness has, for most bearings, changed over the years.
- 2 We now have a better understanding of how interference fit can influence bearing fatigue life.
- 3 The basic dynamic load rating has increased. For example, for the same load and nominal life, if a bearing weighing 18 kg was needed in the 1950s, a 5,25 kg one today will do the job with much less heat generation due to friction. Due to ring thickness and elastic deformation due to load, this has a direct impact on what interference fit to choose.
- 4 Bearing internal geometry has also changed over the years.

Consequently, the time has come to modify the table. As promised in the first issue of SKF Pulp & Paper Practices, I will explain how to choose the correct interference fit for the operating conditions, but in a future issue. In the meantime, see the SKF Drive-up data tables (→ **table 1** and **2**) for the new recommended values for reduction of internal clearance and drive-up for spherical roller and CARB toroidal roller bearing bearings.

Philippe Gachet is an SKF application engineer who has been working with the heavy industries, particularly pulp and paper, since 1990. He can be contacted at philippe.gachet@skf.com



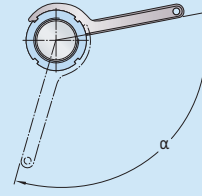
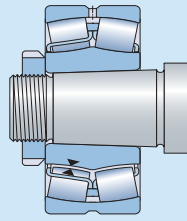
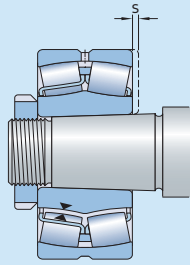

Bore diameter d		Reduction of radial internal clearance		Axial drive-up s ^{1), 2)}		Taper		Lock nut tightening angle ²⁾
over	incl.	min	max	min	max	1:12	1:30	Taper 1:12
		mm		mm		min	max	α
								degrees
24	30	0,010	0,015	0,25	0,29	–	–	100
30	40	0,015	0,020	0,30	0,35	–	–	115
40	50	0,020	0,025	0,37	0,44	–	–	130
50	65	0,025	0,035	0,45	0,54	1,15	1,35	115
65	80	0,035	0,040	0,55	0,65	1,40	1,65	130
80	100	0,040	0,050	0,66	0,79	1,65	2,00	150
100	120	0,050	0,060	0,79	0,95	2,00	2,35	
120	140	0,060	0,075	0,93	1,10	2,30	2,80	
140	160	0,070	0,085	1,05	1,30	2,65	3,20	
160	180	0,080	0,095	1,20	1,45	3,00	3,60	
180	200	0,090	0,105	1,30	1,60	3,30	4,00	
200	225	0,100	0,120	1,45	1,80	3,70	4,45	
225	250	0,110	0,130	1,60	1,95	4,00	4,85	
250	280	0,120	0,150	1,80	2,15	4,50	5,40	
280	315	0,135	0,165	2,00	2,40	4,95	6,00	
315	355	0,150	0,180	2,15	2,65	5,40	6,60	
355	400	0,170	0,210	2,50	3,00	6,20	7,60	
400	450	0,195	0,235	2,80	3,40	7,00	8,50	
450	500	0,215	0,265	3,10	3,80	7,80	9,50	NOTE: Applying the recommended values prevents the inner ring from creeping, but does not ensure correct radial internal clearance in operation. Additional influences from the bearing housing fit and temperature differences between the inner ring and outer ring, must be considered carefully when selecting the bearing radial internal clearance class. For additional information, contact the SKF application engineering service.
500	560	0,245	0,300	3,40	4,10	8,40	10,30	
560	630	0,275	0,340	3,80	4,65	9,50	11,60	
630	710	0,310	0,380	4,25	5,20	10,60	13,00	
710	800	0,350	0,425	4,75	5,80	11,90	14,50	
800	900	0,395	0,480	5,40	6,60	13,50	16,40	
900	1 000	0,440	0,535	6,00	7,30	15,00	18,30	
1 000	1 120	0,490	0,600	6,40	7,80	16,00	19,50	
1 120	1 250	0,550	0,670	7,10	8,70	17,80	21,70	
1 250	1 400	0,610	0,750	8,00	9,70	19,90	24,30	
1 400	1 600	0,700	0,850	9,10	11,10	22,70	27,70	
1 600	1 800	0,790	0,960	10,20	12,50	25,60	31,20	

Valid only for solid steel shafts and general applications.

¹⁾ Not valid for the SKF Drive-up Method.

²⁾ The listed values are to be used as guideline values only, as it is difficult to establish an exact starting position. Also the axial drive-up s differs slightly between the different bearings series.

Table 1. Drive-up data for spherical roller bearings with a tapered bore
Table from SKF Maintenance Handbook

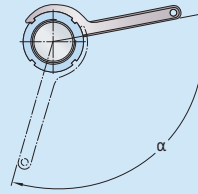
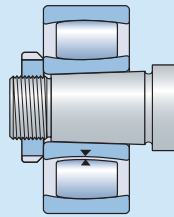
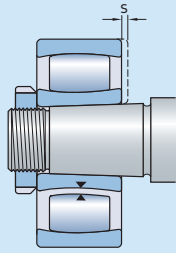

Bore diameter d		Reduction of radial internal clearance		Axial drive-up $s^{1), 2)}$ Taper 1:12		Taper 1:30		Lock nut tightening angle ²⁾ Taper 1:12
over	incl.	min	max	min	max	min	max	α
mm		mm		mm				degrees
24	30	0,010	0,015	0,25	0,29	–	–	100
30	40	0,015	0,020	0,30	0,35	0,75	0,90	115
40	50	0,020	0,025	0,37	0,44	0,95	1,10	130
50	65	0,025	0,035	0,45	0,54	1,15	1,35	115
65	80	0,035	0,040	0,55	0,65	1,40	1,65	130
80	100	0,040	0,050	0,66	0,79	1,65	2,00	150
100	120	0,050	0,060	0,79	0,95	2,00	2,35	
120	140	0,060	0,075	0,93	1,10	2,30	2,80	
140	160	0,070	0,085	1,05	1,30	2,65	3,20	
160	180	0,080	0,095	1,20	1,45	3,00	3,60	
180	200	0,090	0,105	1,30	1,60	3,30	4,00	
200	225	0,100	0,120	1,45	1,80	3,70	4,45	
225	250	0,110	0,130	1,60	1,95	4,00	4,85	
250	280	0,120	0,150	1,80	2,15	4,50	5,40	
280	315	0,135	0,165	2,00	2,40	4,95	6,00	
315	355	0,150	0,180	2,15	2,65	5,40	6,60	
355	400	0,170	0,210	2,50	3,00	6,20	7,60	
400	450	0,195	0,235	2,80	3,40	7,00	8,50	
450	500	0,215	0,265	3,10	3,80	7,80	9,50	
500	560	0,245	0,300	3,40	4,10	8,40	10,30	
560	630	0,275	0,340	3,80	4,65	9,50	11,60	
630	710	0,310	0,380	4,25	5,20	10,60	13,00	
710	800	0,350	0,425	4,75	5,80	11,90	14,50	
800	900	0,395	0,480	5,40	6,60	13,50	16,40	
900	1 000	0,440	0,535	6,00	7,30	15,00	18,30	
1 000	1 120	0,490	0,600	6,40	7,80	16,00	19,50	
1 120	1 250	0,550	0,670	7,10	8,70	17,80	21,70	
1 250	1 400	0,610	0,750	8,00	9,70	19,90	24,30	
1 400	1 600	0,700	0,850	9,10	11,10	22,70	27,70	
1 600	1 800	0,790	0,960	10,20	12,50	25,60	31,20	

NOTE: Applying the recommended values prevents the inner ring from creeping, but does not ensure correct radial internal clearance in operation. Additional influences from the bearing housing fit and temperature differences between the inner ring and outer ring, must be considered carefully when selecting the bearing radial internal clearance class. For additional information, contact the SKF application engineering service.

Valid only for solid steel shafts and general applications.

¹⁾ Not valid for the SKF Drive-up Method.

²⁾ The listed values are to be used as guideline values only, as it is difficult to establish an exact starting position. Also the axial drive-up s differs slightly between the different bearings series.

Table 2. Drive-up data for CARB toroidal roller bearings with a tapered bore
Table from SKF Maintenance Handbook

Store rooms often reflect maintenance practice

When I visit a mill for the first time, I always ask to visit the workshop and the store room for spare parts and lubricants. This often gives a useful insight into how the maintenance department operates.

I often see that the customer has chosen quality products from reliable suppliers, but then stores them in places where they will degrade fast. This is especially true for lubricants with barrels and containers put in places that are not used for any other purpose because they are small, dark, cold and dirty. That said, it is not uncommon to see bearings and seals kept in a place where it is difficult to keep order and cleanliness under control either (→ **fig. 1**).

Smaller bearings are often bought in bulk packaging and, after taking a few out, the packaging is torn and open. The products are literally left lying there collecting dust. If the environment is humid, moisture will be absorbed by the dust and find its way deep in to the product. When such bearings are used on a machine, people wonder why they fail so fast and so often.

With larger bearings the situation is slightly different, but not any better. They are single packed, but are often taken out of the packaging to check the type. Does it have a tapered bore or a cylindrical one? Does the designation on the bearing differ from what it says on the box? Sometimes new bearings are used leaving a perfectly good box to keep bearings that were dismantled from the machine and which are assumed to be still in good order. People can then forget to change the designation on the outside of the box which can create confusion. Instead of what they think they have in stock, they have a completely different bearing in the box. That means that when a job needs such a bearing, it needs to be purchased and delivered urgently. To avoid such things from happening, training and management is needed.

It's also a question of culture: Have you ever been in an environment where the floors were dirty, the walls were black from dust and the light was dim? (→ **fig. 2**) Suppose you were to find a piece of paper in your pocket in this environment, what would you do? Many people would throw it on the floor.

Imagine now that you are in a clean environment, with shiny floors, clean walls and bright light. Would you throw the paper on the floor? I doubt it. This is an important reason to create clean workshops and store rooms. It will be simpler and more natural to keep it clean. I know a company that used white storage racks and painted their production machines white for this very reason.

At one mill that I am working with at the moment, SKF undertook a failure analysis on over 100 bearings. The bearings were collected over a few months and tagged so that their application could be identified. Analysis of the causes of failure showed that contamination was their biggest problem. This could, of course, be the result of a number of reasons including the way the bearings are stored. It turned out that new bearings in stock were already contaminated with layers of dust and light corrosion (→ **fig. 3**). To eliminate this problem, the store rooms were upgraded.

We found a similar situation with the mill's lubricants. On inspection, we learnt that there was water in the lubricant before it was even used (→ **diagram 1**). This was the result of poor storage practices.



Fig. 1 Bearings, if left unpackaged, collect dust



Fig. 2 Dust is captured in open grouting.

Fig. 3 Bearing, in storage, corroded by humidity.



Like bearings or valves, lubricants should be considered as working components in mechanical systems. Just as one would not install a dirty or damaged bearing on a piece of equipment using the wrong tools, “damaged” lubricants should not be added to the machine. The first step toward achieving proactive maintenance of your lubricants, and ultimately your equipment, begins with proper in-plant storage and handling.

Some basic guidelines, based on my experience, follow.

Storage of parts

Lighting

Adequate lighting is important in a store room setting. Think about your general lighting needs first and then about specialized needs for specific areas. There are different lighting options available, but for a store room the minimum is 200 lux.

Floor

Firstly, the floor of a store room should have sufficient load-carrying capacity. Laden forklift trucks can damage floors easily. Racks can also easily create a high load on the floor.

Floors should be easy to clean. This means that dirt should be easy to detect and remove. Therefore, seamless and light coloured floors with a smooth, shiny surface are recommended. There are a number of suitable solutions on the market like epoxy or urethane.

Walls

Store room walls should be able to carry all the necessary racks and boards. They should be light coloured to create a bright working environment. They should be sealed and not have edges or ridges where dust can accumulate.

Ceiling

The ceiling should be sealed and not have any areas where dust can accumulate. It should be no lower than 2,40 m to ensure adequate ventilation and space for personal manoeuvrability. This often is determined by law. Depending on the roof construction, the ceiling may need to be insulated in order to keep a constant temperature inside without having high costs for cooling in summer and heating in winter.

Racks

For storing bigger parts it is advisable to use racks in the store room that can be adjusted in height. In this way the racks can be used in the most efficient way (→ fig. 4) Because the ceilings of rooms are often high, the room can be arranged efficiently in this way. For the smaller parts, smaller racks can be used.

Parts should never be left on the floor either in the store room or the workshop. Left on the floor, the parts cannot be located, There should be a place for everything and everything should have a place. On top of that, parts may get dirty or even damaged by trolleys or trucks.

Recommended storage time

For the recommended storage time of bearings, see (→ table 3). The limitation on storage is due to the preservatives, the lubricant, the sealing and the packaging material itself (→ fig. 5).

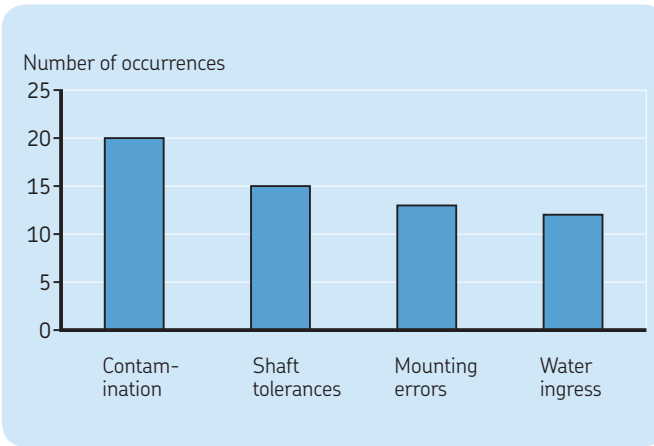

Diagram 1 Bearing failure analysis

Fig. 4 Racks with adjustable shelves

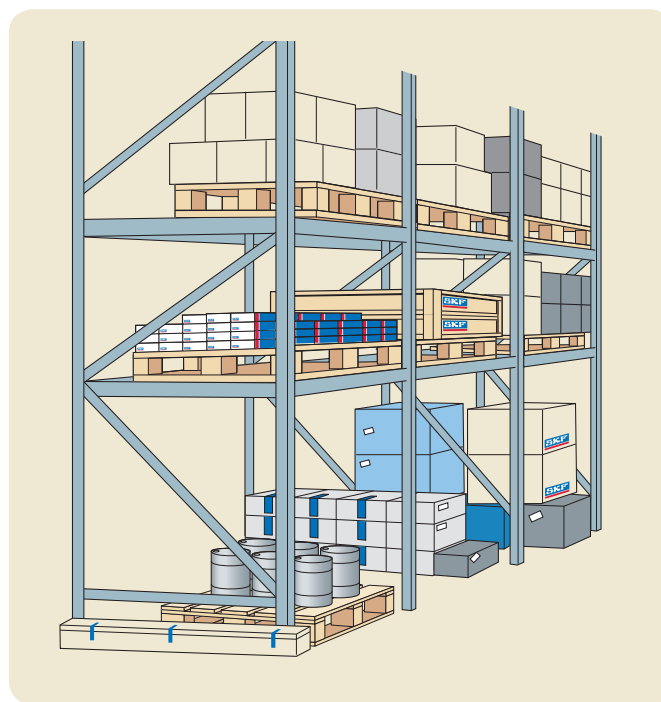

Table 3 Recommended maximum storage time (from the packing date)¹⁾

Relative air humidity	Temperature	Storage time
%	°C	years
60	20–25	10
75	20–25	5
75	35–40	3
Uncontrolled tropical conditions		1

¹⁾ Recommendation is valid for open bearings only. For lubricated (sealed) bearings, recommended time is 3 years maximum.



Fig. 5 Old bearings in storage (dated 1971 – 1977)

Storage of lubricants

Most lubricants have supplier recommended shelf lives based largely upon the additive package. For example, the performance of lubricants containing rust inhibitors may degrade after as little as six months in storage. Learn how to read the coded date on the container label. Shelf life is based on ideal storage conditions and most manufacturers provide a recommended storage procedure to maximize lubricant shelf life. The following conditions have been proven to adversely affect a lubricant's storage life:

1 Temperatures

Temperature fluctuations will cause movement of air between the atmosphere and the head-space of the container. For partially full containers, with greater head-space, this air movement is increased. Although the drum is sealed and does not leak lubricant, a container still inhales air when the temperature drops and exhales as the temperature rises. Along with the air, moisture and small airborne particles enter the oil container possibly leading to degradation of the base stock and additives. Also, water might condense within the drum, drop to the bottom and get pumped to the machine during a top-off. Extreme hot or cold can cause chemical degradation. As mentioned earlier, rust inhibitors may suffer significant performance losses after only six months of normal storage.

2 Humidity

Petroleum-based lubricants are hygroscopic. When exposed to humid air, they naturally absorb airborne moisture. The moisture immediately begins to degrade the additive package and accelerates oxidation of the lubricant's base stock once it is put into service.



Fig. 6 Horizontal storage

3 Storage

Containers and drums must be stored in a clean and dry location. Storage temperatures should remain moderate at all times. Lubricants in storage should be located away from all types of industrial contamination including dust and humidity. Ideally, lubricants are stored in the horizontal position on proper storage racks allowing the containers to be rotated and used on a first-in, first-out basis (→ fig. 6).

While indoor storage of lubricants is recommended, this is not always possible due to environmental, financial or space constraints. If lubricants must be stored outdoors, track lubricant consumption carefully and replenish inventories "just-in-time" to minimize exposure to adverse conditions. If lubricants must be stored outside, shelter them from rain, snow and other elements. Lay drums on their sides in a horizontal position with the tap point below the lubricant level. This will greatly reduce the risk of the seals drying out and the ingestion of moisture caused by breathing. If the drums must be placed upright in outdoor storage, employ drum covers or tilt drums to drain the moisture that gathers on the top around the bungs. Avoid outdoor storage of water-based fluids where extreme temperatures can have an even more damaging effect through freezing and evaporation.

Once the seal is broken and the container is put into use, care must be taken to ensure control over contamination ingress. If equipped with a proper pressure relief, bulk tanks should use filter breathers to control contamination ingestion. Drums and pails should be capped when not in use. If your drums are frequently used, bung breather filters may be your best solution.

When you prepare a meal, you want it to be prepared in a clean kitchen using fresh, good quality ingredients. Then you are sure that the end result will only depend on the way that the meal is prepared. In maintenance, you want to make sure that the materials you are using are in good condition and kept in a clean environment. A lot of unnecessary failures can be prevented this way. It is a small investment for a significant benefit.

Regards,
 Rene van den Heuvel
 Maintenance Solutions Manager
 Pulp & Paper, SKF
 rene.van.den.heuvel@skf.com



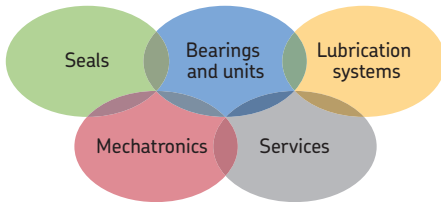

The Power of Knowledge Engineering

Drawing on five areas of competence and application-specific expertise amassed over more than 100 years, SKF brings innovative solutions to OEMs and production facilities in every major industry worldwide. These five competence areas include bearings and units, seals, lubrication systems, mechatronics (combining mechanics and electronics into intelligent systems), and a wide range of services, from 3-D computer modelling to advanced condition monitoring and reliability and asset management systems. A global presence provides SKF customers uniform quality standards and worldwide product availability.

SKF Global Pulp & Paper Segment

Contact/Responsible editor
philippe.gachet@skf.com

© SKF, CARB and SensorMount are registered trademarks of the SKF Group.

© SKF Group 2011

The contents of this publication are the copyright of the publisher and may not be reproduced (even extracts) unless prior written permission is granted. Every care has been taken to ensure the accuracy of the information contained in this publication but no liability can be accepted for any loss or damage whether direct, indirect or consequential arising out of the use of the information contained herein.

PUB 72/S9 11147/3 EN · January 2012

Certain images used under license from Shutterstock.com.





As good as new?

Bearing remanufacturing? How can SKF offer such a service? What about the quality and performance of remanufactured bearings?

I get asked these sorts of questions all the time. Often they are from people who are for some reason reluctant to use remanufactured bearings. I tell such people that we have many satisfied customers and that remanufacturing can be a good way to reduce maintenance costs. I also tell them that it can help solve problems related to bearing availability or repetitive failure and contribute to better machine reliability.

The main article in this issue of SKF Pulp & Paper Practices is written by an engineer who was originally quite sceptical about bearing remanufacturing. Today, he agrees that if it is done in a professional way - taking into account the application and customer

needs - it is a valuable service that SKF can provide. Many of our customers clearly agree with him as today the pulp and paper industry is the largest user of our remanufacturing services.

We will continue to open more and more remanufacturing centres around the world to serve the pulp and paper industry, to reduce maintenance costs and to help keep the machines running. For me, remanufacturing is a great success and I would like to thank all of our customers for their trust in us.

Regards,
Franck Pellerin,
Centre of Excellence, Bearing Remanufacturing
franck.pellerin@skf.com



Bearing remanufacturing

In this issue of SKF Pulp & Paper Practices, I write about bearing remanufacturing. Some people call it bearing repair or bearing refurbishment, but whatever you call it, it's taking a bearing that isn't too badly damaged and reworking it to extend its service life.

When I was an application engineer working with the French paper industry, I was often asked to come and look at large size bearings which were sometimes still mounted on the paper machine. The people at the mills wanted to know whether the bearings could be put back in operation. Such questions were never easy to answer.

With bearings still mounted on a machine, I could only gauge their condition by using a bent wire (see figure 1). Even with dismounted bearings where I could see all the surfaces and which appeared to be in good condition, I always wondered about the state of the steel under the surface. The fact of the matter is that a bearing can have raceways that look good despite the presence of micro cracks in the subsurface. These cracks - which are not visible to the human eye - mean that the bearing is near the end of its life.

Under normal operating conditions, a bearing has to withstand the maximum shear stress below the surface. If it is sufficiently loaded, after a while, the material structure will change and micro cracks will appear (see figure 2).

As such, I couldn't be sure of the real condition of any bearing that had been in operation for some time. With experience, and knowing the operating conditions plus the time in service, I could estimate whether a bearing was good for another year or not. I was normally right. Probably because most bearings in paper machine applications develop raceway surface damage before subsurface fatigue cracks appear and because the nominal rating life is often well

above 100 000 hours. This means that if everything is perfect 90 per cent of bearings working in identical conditions will last longer than 100 000 hours. Nevertheless, I was never completely comfortable telling a customer that a bearing could be put back into operation.

For bearings with minor surface damage, I felt that it was a pity to scrap them especially when availability of new bearings was an issue. As such, we often simply rotated the ring that was subject to a fixed load direction (generally the outer ring) so that there was a new load zone on it. For bearings that had significant damage to the rollers or the rotating ring, I'd recommend replacement with a new one.

Grinding the raceway surface and possibly changing the rollers was something that I had in mind in the early 1990s. I knew that some bearings were sent back to the factory for this even though it was disturbing the flow of the normal production. Even so, I still had concerns relating to the subsurface condition of the steel.

The answer, of course, was ultrasonics which has proven to be a good solution for finding subsurface micro cracks. There is a story from the days before remanufacturing centres existed in SKF. A Swedish paper mill asked SKF to remanufacture a large press roll bearing and we accepted the work on the condition that there were no subsurface micro cracks. The bearing ended up being remanufactured twice before the ultrasonic test showed that it should not be done a third time. While the bearing still looked in good condition, the work required to remanufacture it again - grinding the inner and outer ring raceways to remove the damage steel, replacing the rollers with oversized new ones to keep the same clearance class - would have meant it cost more than a new bearing.

Fig. 1 Figure 1 Bent wire with a point. You can see me using this tool on the front cover of SKF Pulp & Paper Practices, Issue 2.



Fig. 2 Micro crack caused by fatigue 130 microns below the surface.

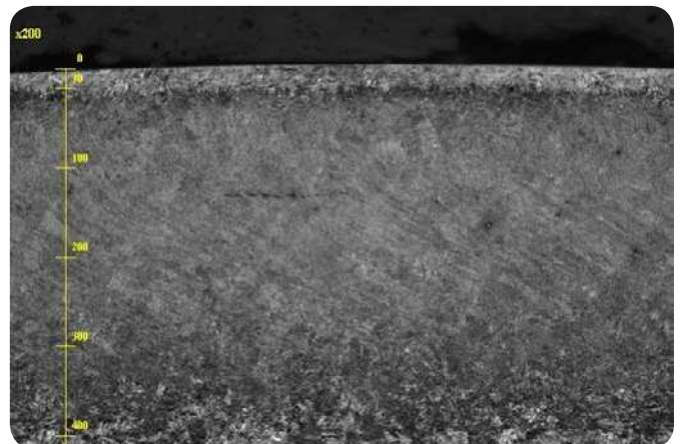



Fig. 3 Ultrasonic testing for subsurface micro cracks in the outer ring of a spherical roller bearing.

This story shows that had specialized remanufacturing centres existed, many more bearings could have been saved providing that appropriate ultrasonic tests had been available (see figure 3).

When our dedicated and specialized bearing remanufacturing centres started, they didn't use the same raceway and roller surface grinding and honing process that is used in our factories for new bearings. While this isn't an issue for some types like cylindrical roller bearings, it can be an issue for spherical roller bearings. For these, inner and outer ring raceway geometry and roughness differences guide the rollers to roll with a small skew angle that reduces internal friction and thus bearing operating temperature. The friction reduction is very noticeable when the bearing load is such that one row of rollers becomes unloaded. When remanufactured bearings merely have their raceways polished to remove minor surface damage, there might be not enough sufficient roughness differences between the raceways to optimally reduce friction.

Unlike facilities for mass production, it is not practical for remanufacturing centres to have machines dedicated to one bearing type or size range. Instead, more flexible machines are needed. However, with such machines it is either more time consuming or impossible to remanufacture some special bearings to the original SKF specifications. I'm thinking about very high running accuracy bearings like the VQ424 and VA460 variants here.

In addition, customers were – and still are – sending bearings to us for remanufacturing without any indication of the operating conditions or the amount of hours they had been in service. Furthermore, they weren't – and still aren't – opting for ultrasonic testing first. The risk of undetected subsurface micro cracks if no ultrasonic analysis is done isn't negligible. Several cases of remanufactured bearings developing spalling due to subsurface micro cracks after a few weeks or months in service stayed in my mind. For these reasons, I didn't think that remanufacturing was a good idea unless new bearings couldn't be sourced in time.

However, I had to face reality. This reality was that an increasing number of remanufactured bearings were being sent to satisfied customers who were saving money. The SKF remanufacturing centre in Steyr, Austria received 1 119 large size bearings from paper industry customers between 1998 and 2002. Of these, 149 were scrapped and all the others were repaired. Some paper mills were

reducing their yearly bearing spend by up to 10–12 per cent due to the savings from remanufactured bearings. Such bearings – ignoring ultrasonic testing – typically cost 50–80 per cent of the price of a new bearing.

It should be noted that a bearing doesn't always need to be remanufactured to the original specifications. It depends on the application. Let's look at some examples.

A spherical roller bearing mounted on a Yankee cylinder doesn't rotate at high speed and its operating temperature is dictated by the steam temperature. Friction isn't the most important parameter. Running accuracy and the steel quality are, on the other hand, important. So, if the bearing is just polished, that's acceptable.

A spherical roller bearing with C08 specification (i.e. four times better running accuracy than normal ISO precision) mounted on a solid plain press roll, doesn't always need to be C08 after remanufacturing. C08 means P5 running accuracy for the inner ring (suffix C02) and P5 running accuracy for the outer ring (suffix C04). The running accuracy depends mainly on the rings wall thickness variation and the roller diameter deviation in a roller set. As the inner ring rotates, it has to keep the original running accuracy. But the outer ring has a loaded zone that is normally less than half of the raceway circumference. If this is the case, wear is in the loaded zone and the unloaded zone still has the same geometry as when it was new. If the bearing is remounted with a previously unloaded zone as the new load zone, it is sufficient that the outer ring wall thickness variation in the new load zone is within original tolerances. This should normally be the case. While the bearing isn't C08 anymore, with the outer ring positioned correctly in the application, it will operate like a C08 bearing.

N.B. The remanufacturing traceability number on the bearing side face is positioned so that it coincides with the center of the new load zone (see figure 4).

Another example: A 23040 CCK/C4W33 drying cylinder bearing that has been stored in a humid environment. It has some standstill corrosion marks. Nearly all corrosion marks have been taken away during remanufacturing, but in one area – the outer ring – some were so deep that there are still some marks remaining. The remaining corrosion marks are in the unloaded zone of the outer ring when the bearing will be mounted and the bearing doesn't run at

Fig. 4 Traceability number indicating the centre of the new load zone. Here it is marked on the bearing inner ring since it is for a deflection compensating roll where the outer ring rotates with the cylinder.



very high speed meaning that the centrifugal forces pushing the rollers against the outer ring are small. The bearing can be put into operation with these remaining corrosion marks.

Some parts of the bearing do not need to be remanufactured. For example, corrosion marks on the face of the rings do not need to be fully removed if there is no load on the surface and or the surface has no influence in the bearing mounting, adjustment and operation.

Remanufacturing objectives

We must keep in mind that the objective isn't to remanufacture a bearing so that it is equivalent to a brand new one, it's to increase the service life of the bearing. Service life is generally limited by raceway damage due to lubrication, contamination, or marks due to bad handling or storage. On a paper machine, most of the bearings do not reach their potential service life. This is mainly due to lubrication and contamination issues. A dent created by an over-rolled hard particle, or a surface micro crack due to corrosion, disturbs the load distribution along the roller/raceway contact surface. It changes the stress in the subsurface. The stress is locally increased and accelerates fatigue. By removing the surface damage, the service life is increased compared to what it would have been if the surface damage was left in place.

Depending on the bearing operating conditions in the application, an appropriate remanufacturing work level can be selected avoiding costly, unnecessary operations. However, I wouldn't recommend remanufacturing certain bearings. For highly loaded, high speed bearings – sometimes running near, or even above their SKF General Catalogue speed limit – it is better to check with the local SKF application engineer on a case by case basis. I have in mind, for example, VA460 spherical roller bearings and CARB toroidal roller bearings designed for very high speeds mounted on plain press rolls and some special spherical thrust roller bearings for high speed refiners.

Also, some bearings are quite old having been more than 15 to 20 years in operation or having run more hours than the calculated rating life. In such cases, a better solution is to replace them instead of remanufacturing them. The SKF pulp and paper bearing expert team, comprised of application engineers with an average of 18 years experience in bearings and pulp and paper applications, has

created an internal guideline about bearing remanufacturing for the pulp and paper industry. In this guideline, we recommend not remanufacturing bearings that have achieved more than 50 per cent of the calculated SKF rating life L_{10mh} . Of course, this guideline can be ignored in situations where it's better to remanufacture rather than have a machine stopped due to the lack of availability of a new bearing. Once again, it's better to contact the SKF application engineer and take a decision based on the operating conditions.

If all this is understood, I'm fully convinced that remanufacturing is a good way to reduce total cost and limit waste.

Can all bearings be remanufactured?

No, of course not. There can be many reasons – technical or commercial – for this. While we have many bearing experts in SKF who can advise on whether a bearing should be remanufactured, sometimes specific circumstances like the lack of availability of new bearings can lead to an expert's recommendation being overruled. Nevertheless, for some damage – such as heavy spalling and fractures, remanufacturing is not an option. When it's too late, it's too late (see figure 5).

For some other damage, it can depend. Whether the bearing shown in figures 6 and 7 can be remanufactured depends on the depth of the corrosion and whether the rollers have to be replaced or not. A decision can only realistically be made after an in-depth analysis by an expert.

In other cases where damage is superficial, remanufacturing can be done at low cost. This is the case for the CARB toroidal roller bearing shown in figure 8. It was mounted on a belt calendar and has two standstill corrosion marks on the outer ring. These can simply be removed with polishing. However, no matter how simple the work involved, major damage can occur if it is not done by expert people.

Do not wait until the bearing has failed and the machine stopped before dismounting it. By that time, most bearings are too badly

Fig. 5 Heavy spalling means that this ring needs to be scrapped



Fig. 6 The corroded inner ring of a deflection compensating roll





Fig. 7 The rollers of the bearing shown in figure 6

damaged and cannot be remanufactured. Often, it's even too late by the time you can feel or hear that something is wrong. Condition monitoring and oil analysis are the best tools to detect that bearings are beginning to develop raceway or roller damage. When detected early, plans can be put in place to dismount the bearings during a planned stop and maximize the chances of being able to remanufacture them at the lowest possible cost.

While customers often ask if a bearing can be remanufactured before sending it and incurring freight and customs costs, it isn't always easy to answer this question without seeing the bearing, dismantling it to check its condition and knowing the operating conditions. The first step – if you do not have an SKF specialist available – is to take good quality photographs and to email them to SKF together with information about the application, rotational speed and which ring has the rotating load.

Giving information about rotating load is important. Even though we can generally tell – based on marks on the raceway – which ring rotates compared to the load direction, it is best to indicate this anyway. Even simply telling us the bearing designation can also help sometimes. For example, a spherical roller bearing 23068 CC/C08W513 – a bearing with a cylindrical bore and lubrication holes in both the inner and outer rings – is quite often used on deflection compensating press rolls or as the front side bearing on old suction roll designs. That said, I have also seen this bearing mounted with a tight fit on a rotating shaft as a replacement for a 23068 CC/W33 so, the designation can only tell us so much.

Giving information about load, lubrication and the bearing's operating time is also helpful to evaluate the remanufacturing possibilities.

Regarding photographs, we often see pictures that aren't good enough quality to allow us to make a reliable judgement on the damage. While we don't expect to see professional quality photographs, we do need to see ones that are in focus, adequately lit and without the detail obscured by flash reflections. One other thing to keep in mind is that it is difficult to estimate the depth of any damage from a photograph. As such, any indication that you can give us about depth is very useful.

Even if a bearing is sent to an SKF remanufacturing centre directly, it's still important to give us the information mentioned above.

Let's take the example of a VQ424 (high running accuracy suffix) bearing, mounted on a high speed deflection compensating roll that has standstill corrosion marks on the outer ring. All the other parts are in good condition and will not need to be touched. The outer ring will have to be ground because we want to keep adequate roughness difference between the inner and outer ring raceways to minimise friction. Keeping the same roller set, the bearing will be a C4 clearance class instead of the C3 that it was originally because, before grinding, it was near the upper limit of the C3 clearance class. To make the remanufactured bearing C3, it would have to be equipped with new, oversized rollers. This would have a huge impact on the cost. However, if the SKF application engineer knows the application and operating conditions, he is able to tell whether C3 clearance is really needed and can advise his customer accordingly.

Fig. 8 Dismounted CARB toroidal roller bearing at a paper mill ready for inspection before being sent for remanufacturing



SKF remanufacturing centre services

SKF remanufacturing centres offer several service levels plus options depending on the bearing involved, the type of damage and, most importantly, the application.

When a bearing arrives at an SKF remanufacturing centre, it is visually inspected first and some parameters like residual magnetism and clearance are checked. This gives an initial impression about the state of the bearing and whether it can be remanufactured or not. After this, the bearing is disassembled and thoroughly cleaned (see figure 9).

The components are then inspected and their dimensions measured. Some measurements and inspections are optional. Ultrasonic testing, hardness, roller diameter set variation, outer dimensions are, for example, optional while ring wall thickness and ovality are examples of measurements that are always taken.

For bearings mounted in critical applications such as press rolls or Yankee cylinders where the operating hours are unknown, I would recommend the ultrasonic testing option. Remember that it's an option so, you have to request it when you send a bearing to an SKF remanufacturing centre.

Classification of the damage is done according to ISO norm 15243 for eventual root cause failure analysis. Following the ISO norm is important because it ensures that everyone has the same understanding of the terms and definitions used to describe bearing damage.

Following this, an offer with a report is sent to the customer though remanufacturing won't start unless a customer order is placed.

In SKF, there are 4 levels of service. Here's a quick overview of them:

- 1 Level 1 is just inspection and scrap
- 2 Level 2 is inspection, repacking with adequate protection and return to the customer
- 3 Level 3 is inspection, remanufacturing by polishing, repacking with adequate protection and return to the customer. For high speed applications, where low friction is a key parameter – or if the spherical roller bearing has to withstand high axial load – I recommend contacting your local SKF application engineer to decide whether level 3 or level 4 remanufacturing is necessary.
- 4 Level 4 is inspection, remanufacturing with some grinding (see figure 10) and/or part replacement, repacking with adequate protection and return to the customer. Note that with level 4, spherical roller bearings keep the inner and outer ring raceway roughness differences for minimum friction, due to the specific grinding techniques used.

Before being sent back to the customer, the bearing parts are quality checked (see figure 11) and reassembled with care. For example, figure 12 shows a plastic sheet placed between the outer ring and the rollers to avoid micro smearing marks when rotating and/or swivelling the inner ring while putting the rollers in position.

Fig. 9 Bearing being disassembled at an SKF remanufacturing centre.



Fig. 10 Level 4 grinding of a spherical roller bearing outer ring





Fig. 11 Ring ovality and wall thickness variation measurement



Fig. 12 Special care is taken during assembly to ensure that rollers do not mark the raceway.

I hope that this article has given you a better understanding of re-manufacturing and its limitations. Please keep in mind that:

- 1 Remanufacturing doesn't transform a used bearing into a brand new one, it simply increases its service life.
- 2 Information about the application, the running conditions and the operating hours helps SKF propose the most cost effective re-manufacturing process for you.
- 3 For critical applications when operating hours are unknown or when the bearing has been in operation for more than half its SKF rating life, I strongly recommend ultrasonic testing.



Philippe Gachet is an SKF application engineer who has been working with the heavy industries, particularly pulp and paper, since 1990. He can be contacted at philippe.gachet@skf.com

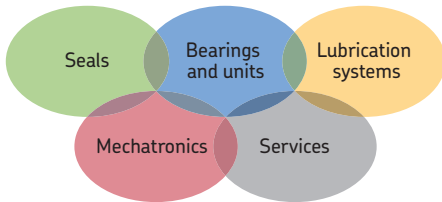

The Power of Knowledge Engineering

Drawing on five areas of competence and application-specific expertise amassed over more than 100 years, SKF brings innovative solutions to OEMs and production facilities in every major industry world-wide. These five competence areas include bearings and units, seals, lubrication systems, mechatronics (combining mechanics and electronics into intelligent systems), and a wide range of services, from 3-D computer modelling to advanced condition monitoring and reliability and asset management systems. A global presence provides SKF customers uniform quality standards and worldwide product availability.

SKF Global Pulp & Paper Segment

Contact/Responsible editor
philippe.gachet@skf.com

© SKF and CARB are registered trademarks of the SKF Group.

© SKF Group 2012

The contents of this publication are the copyright of the publisher and may not be reproduced (even extracts) unless prior written permission is granted. Every care has been taken to ensure the accuracy of the information contained in this publication but no liability can be accepted for any loss or damage whether direct, indirect or consequential arising out of the use of the information contained herein.

PUB 72/S9 1114 7/4 EN · May 2012

Certain images used under license from Shutterstock.com.



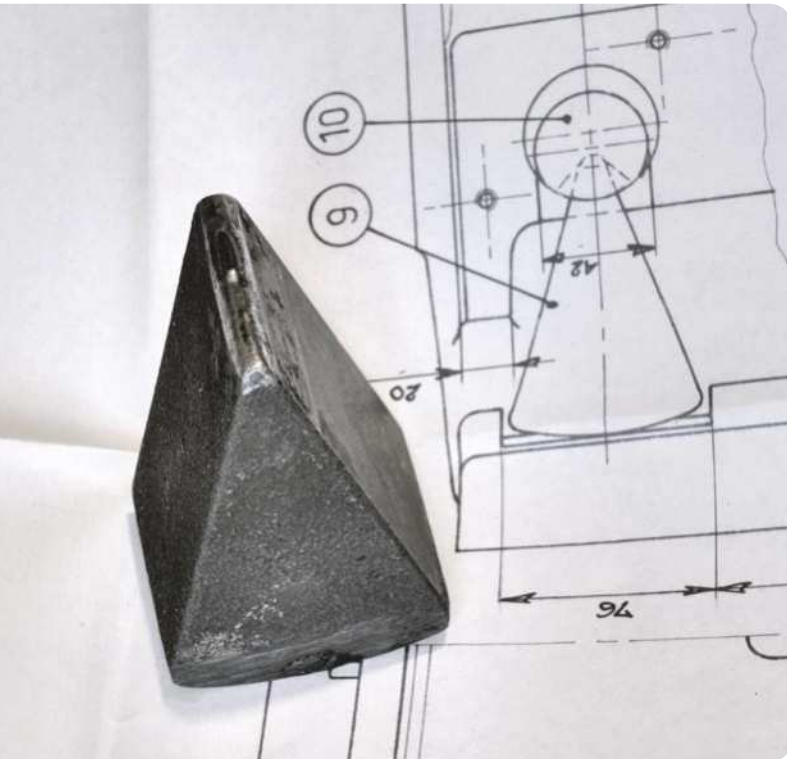

We all have a lot in common whether we see it or not

While my background is in production and operations management in the paper industry in Europe, where I worked for several of the larger paper and tissue producers, I have had the opportunity to broaden my horizons after joining SKF as a process consultant. Since moving to Asia a couple of years ago, I have really enjoyed seeing how things are done in the various mills and countries here.

It is fascinating to see how different mills manage their production processes and the availability of their equipment. Sometimes the differences are quite marked, but I'm very often struck by the similarities as well. Changing daily priorities and dryer section problems, both of which effect production, seem to be fairly universal, for instance.

I recall sitting in a management meeting some years ago, at a mill that I worked at, listening to how pleased everyone was that only one day's production had been lost to a Yankee bearing failure. I remember thinking that it should not have happened at all and

about what could have done to prevent it in the first place. The priority however had been to get production running again as quickly as possible and, to be fair, the team did a good job of doing this. They didn't do such a good job of considering what the service life of the bearing could and should be or on the root cause analysis needed to prevent it happening again. They had moved on to the next item on the list of daily priorities, of course.

This edition of the newsletter and the next are about drying cylinder and Yankee bearings. We will cover the operating conditions, the issues and our recommendations for dealing with them. I hope that you'll find these two newsletters interesting and useful even if they don't help you with your daily priorities!

Regards,
Andy Cross,
Process Consultant, Segment Pulp & Paper
andrew.cross@skf.com



Drying and Yankee cylinder bearings and their lubrication (Part 1)

SKF engineers working with paper mills get asked a lot of questions about bearing clearance, inner ring heat treatment and lubrication for drying and Yankee cylinder applications. In fact, after issues relating to corrosion and contamination from process water in the wet section, these are probably the most common things they have to deal with. As such, this issue of SKF Pulp & Paper Practices will focus on them. It's a broad subject so, in order to cover this matter in sufficient depth, we will also dedicate the next issue of our newsletter to it as well.

Bearing operating conditions

From the bearing perspective, drying and Yankee cylinder applications are rather similar. Bearings don't rotate at high speeds and they aren't heavily loaded. The steam used to heat such cylinders does create some challenges however.

Steam passing through the bore of the journal on which the bearings are mounted (→ fig. 1) causes radial and axial thermal expansion of both the journal and the cylinder.

Axial thermal expansion creates the need for a bearing or housing that can accommodate relatively large axial expansion of the journal relative to the machine frame on the front side.

As steam also heats journals and bearings, and because the former will be hotter than the latter, bearing inner rings have to be able to withstand radial expansion. This creates additional stresses in inner rings on top of those created by mounting them with a tight fit on the seat. Due to the temperature difference between the inner and outer rings of the bearings, larger than normal radial internal clearance is required to maintain some clearance and to avoid preload.

The maximum internal clearance reduction and inner ring stress are experienced during start up with a cold machine. The accompanying drawings (→ fig. 2, 3, 5 and 6) show the calculated temperature distribution over the cross section of an arrangement during start up. These results were tested against an actual drying cylinder – on which temperatures were monitored – and confirmed for oil flows of between one and two litres per minute with slight deviations at high and low oil flow rates. The bearing in our simulation model is a 23052 CCK/C4W33 spherical roller bearing with a rotational speed of 130 rpm and an oil flow rate of 2 l/min. Our model assumes a steam temperature of 180 °C (356 °F) during start up and 130 °C (266 °F) under normal operating conditions.

With the temperature distribution shown in fig. 2, the hoop stress in the inner ring is increased by some 60% i.e. nearly 220 Mpa instead of 136 Mpa after mounting.

Fig. 1 A typical drying cylinder bearing arrangement.

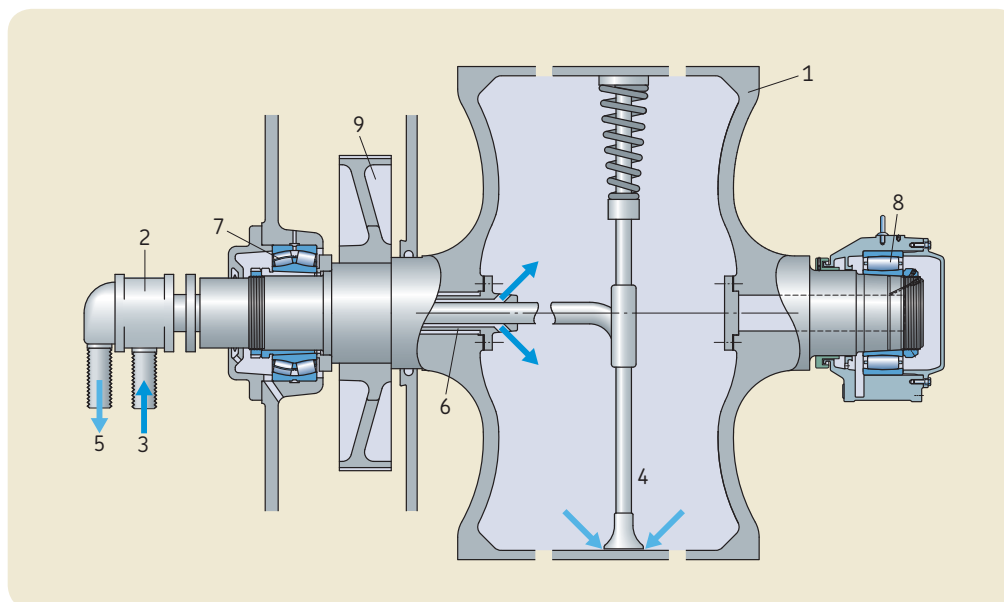

- Drying cylinder arrangement**
- 1 Drying cylinder
 - 2 Steam joint
 - 3 Steam inlet
 - 4 Siphon
 - 5 Condensation
 - 6 Journal insulation
 - 7 Drive side bearing
 - 8 Front side bearing
 - 9 Gear drive

Bearing internal radial clearance is reduced by 0,28 mm in **fig. 2** and 0,12 mm in **fig. 3**. A C4 radial internal clearance class bearing could run preloaded during start up. This does not necessarily impair the function of the bearing, but any error of form of the housing and shaft seating etc. – which are generally compensated for by the radial clearance of the bearing - may make their presence felt when the radial internal clearance is eliminated. This can have a negative effect on bearing life and lead to bearing damage.

If, in our example, the bearing inner ring temperature is near 107–109 °C (225–228 °F), we should remember that where steam is above 170 °C (338 °F) during normal operation, without journal insulation, we can add approximately 20 °C (68 °F) to the bearing inner ring temperature.

As the steam heats up the bearing, the lubricant is also heated and there is a significant difference between the kinematic viscosity of oil under cold and hot conditions.

An air gap between the journal bore and the pipe through which the steam passes (→ **fig. 4**) reduces heat transfer to the bearings. Note that there is also an air gap at the end face of the journal and that without this the temperatures shown in **fig. 5** and **6** would be higher.

By insulating the bore and end face journals, bearing temperatures can be decreased by some 35 °C (95 °F). This has an enormous effect on the lubricant in terms of oil film thickness and service life.

Fig. 2 Temperature distribution 15 to 30 minutes after start up without journal insulation.

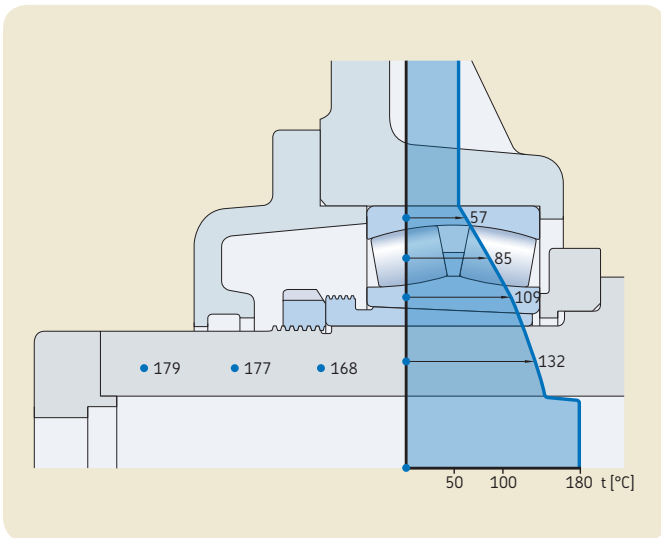

Fig. 3 Temperature distribution during normal operation without journal insulation.

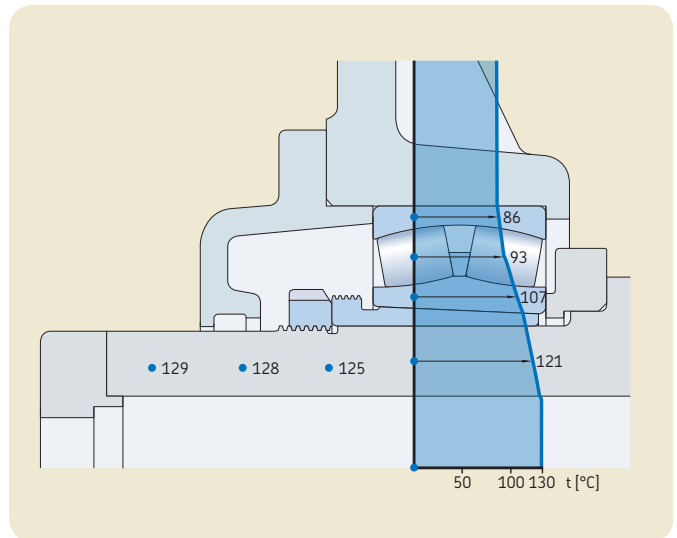
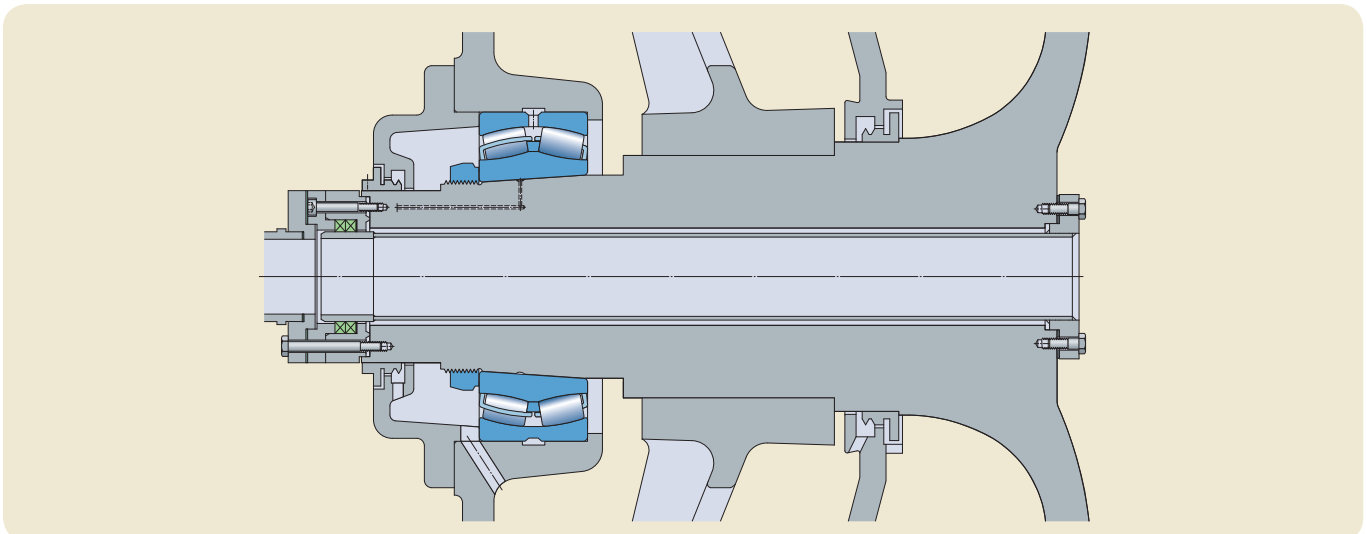

Fig. 4 Air gap insulation on the drive side of a drying cylinder.



Main issues

There are a number of issues that can cause problems in drying and Yankee cylinder applications:

- 1 Premature oxidization of the lubricating oil into a black, sticky sludge or even carbon. I call this “the black death” (→ fig. 7 and 8). It can be caused by using unsuitable oil, too low oil flows, too high temperatures, contamination that accelerates oxidization etc.
- 2 Paper mills reducing oil flow due to leakages which often occur because return pipes are dirty and create high flow resistance.
- 3 The use of unsuitable oil. Many of the products sold as paper machine oils for the dryer section do not pass SKF tests. These tests were developed by SKF in the late 1980s to test and approve new oils and additive packages for the operating conditions found in paper machines. Inadequate oils age quickly and become aggressive to bearing steel.
- 4 Liquid contamination due to condensation, high pressure cleaning, steam joint/stationary siphon leakage. One issue here is that most in-line oil/water separators are not efficient enough to evacuate all the water coming from a steam joint/stationary siphon leakage. This results in a bad balance i.e. more water entering the system than can be removed from it.
- 5 Bearing inner ring cracking issues. This happens most often during start up when the journal is much hotter than the bearing inner ring. The crack typically starts at a position where there is already damage like a dent, subsurface fatigue micro crack, a spall or corrosion. It starts from damage on the raceway or from the bore. Some bearing steel heat treatments are more sensitive than others. Don't believe that case hardened bearings are the only solution. Many customers have used SKF through hardened bearings for many years without problems. That said, some types of heat treatment shouldn't be used for drying cylinder bearings.

- 6 Too high temperatures. This is usually due to old machines, without drying cylinder journal insulation, being speeded up to produce more paper. Instead of adding more drying cylinders and/or having increasing water removal in the press section, steam temperature is increased without adding journal insulation.
- 7 Axial overloading because the outer ring of the axially free spherical roller bearing - traditionally on the front side - cannot slide in its housing. Most often this is due to too high fretting corrosion in the housing bore and/or on the bearing outer diameter. There have also been cases where the temperature difference between the housing and the bearing outer ring was so high that it resulted in an interference fit between the outer ring and its seat.
- 8 Excessive misalignment. This concerns designs that use a cylindrical roller bearing as the axially free bearing. Everything is aligned properly when the machine is built, but, over time, machine frame deformation will occur. Visually, this is hard to see, but it is enough to reduce cylindrical roller bearing life as they are very sensitive to misalignment. Mostly, bearings are replaced and the alignment isn't checked. Placing the housing back in position with the help of marks and/or position pins only is not enough. The first CARB mounted in France on a drying cylinder was at International Paper Saillat sur Vienne. This was in 1996 with CARB replacing a cylindrical roller bearing that was running with too high misalignment since the frame may have moved. In 1997, I replaced 43 cylindrical roller bearings N 3040 K/C4VA701 with CARB C 3040 K/HA3C4 on a 22 year old machine because of repetitive failures. Inspecting these bearings revealed that 15 had a load zone pattern typical of bearings running with too high misalignment and that two of them had already developed spalls.

Fig. 5 Temperature distribution 15 to 30 minutes after start up with journal insulation.

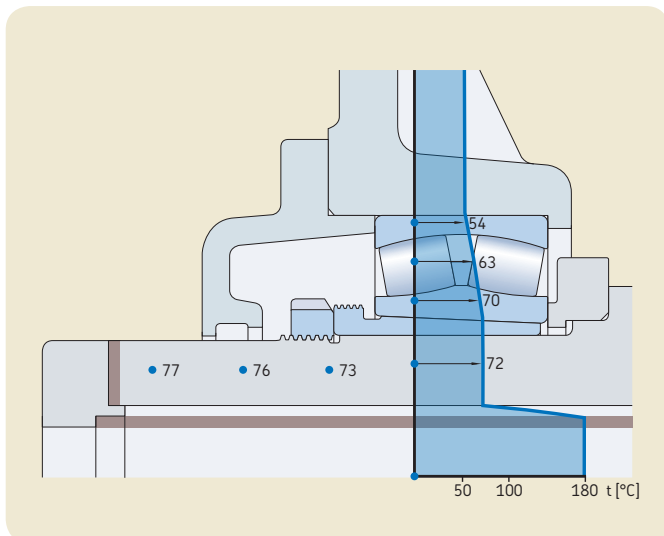
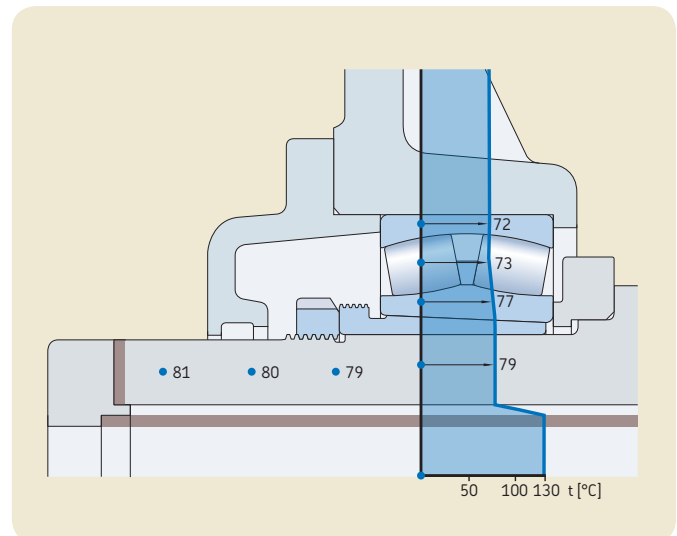

Fig. 6 Temperature distribution during normal operation with journal insulation.



Many of the problems listed above can be linked together. Take the example of an old paper machine without journal insulation. It has been speeded up and the steam temperature has been increased. The lubricating oil, while previously adequate, will age prematurely with the increased operating temperature. The oil will oxidize quickly resulting in inadequate bearing lubrication and contaminating return oil pipes with deposits. These deposits cause resistance to oil flow so the mill reduces the flow rate to minimise leakage. Without adequate lubrication, bearing raceways get damaged which increases the risk of inner ring cracks in future.

Generally, when there is a bearing failure paper mills first question the bearing type and its carrying capacity. In fact, the root causes are mainly related to the oil used, the flow rate, inadequate journal insulation and water content in the oil.

When there is no journal insulation and steam temperatures are high, bearings with case hardened inner rings are often selected. For me, this is only a stop-gap solution since the bearing will have a short service life anyway due to inadequate lubrication. Even very high oil flows will not reduce temperature enough for an adequate oil film to form since excess oil passes too quickly to reduce it. The real solution is to insulate the journals.

Bearing types

There are many different bearings types and bearing arrangements used in drying and Yankee cylinder applications. Let's look at the most common ones.

Today, nearly all drying cylinders have spherical roller bearings on the drive side. There are still some plain bearings used on very old machines as evidenced by the occasional requests I get to work on a conversion to rolling element bearings. In addition, split bearings are sometimes used. At first glance, these seem like a good solution where bearings have short service lives and need to be replaced quickly and easily. However, the weak point is the gap between the two parts of the inner ring. In addition, the tight fit of the inner ring cannot be adjusted with sufficient precision. As such, while SKF can supply split roller bearings, we don't recommend them for paper machine applications.

Fig. 7 Oil transformed into carbon.



My experience is that more bearing types are used on the front side of machines - fewer and fewer plain bearings, lots of spherical roller bearings, some cylindrical roller bearings and, increasingly, CARB. Such diversity is understandable given the axial displacement and misalignment involved and the number of engineers who have tried to solve the resulting problems. Some of these solutions have worked well and others not so well. As such, let's look at the pros and cons of each bearing type.

Firstly, let's consider spherical roller bearings. With such bearings, there are two assembly options: bolting the bearing housing to the machine frame and accommodating axial displacement by the axial displacement of the bearing in the housing (→ fig. 9); or mounting the bearing housing on rockers with the bearing axially located in the housing.

Fig. 8 The black death.



Fig. 9 Bearing housing bolted to the frame with axial displacement accommodated by the bearing which is axially free in the housing.

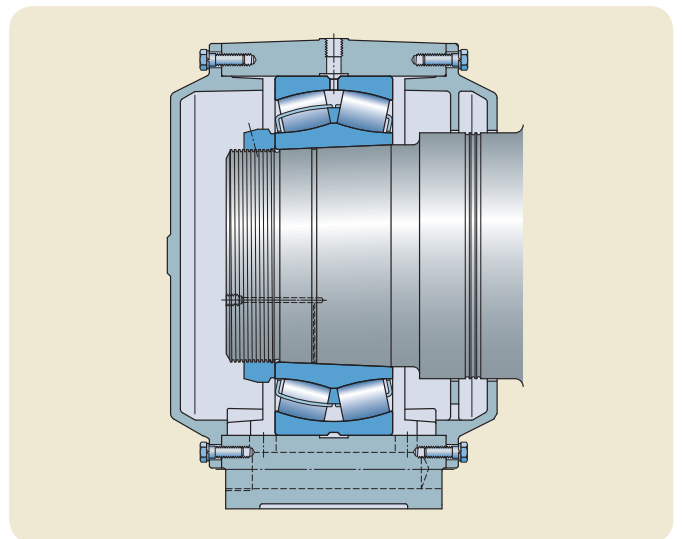

The first option can be found on many old machines and narrow machines that don't run particularly fast and/or don't have high steam temperatures. In such cases, a standard bearing can be used providing it is made from suitably hardened steel like SKF uses. However, two main issues with such arrangements led engineers to search for other solutions.

The first issue is that the outer ring is hotter than the housing. During start up it can expand enough radially to remove any clearance between the outer ring and the housing bore. This leads to the outer ring getting stuck and the bearing becoming axially overloaded leading to premature failure. To avoid this, the bearing is mounted with a very loose housing bore fit – typically F7, sometimes E7 instead of the typical G7. However, during normal machine operation, the housing reaches a temperature where the fit is too loose and this increases the risk of fretting corrosion.

Secondly, with high axial displacement, fretting corrosion in the outer ring to housing contact zone is quite common. This is exacerbated by water content in the oil – caused by condensation, the humid environment and high pressure cleaning – and oil ageing. When the bearing moves axially due to thermal expansion of the drying cylinder, the outer ring doesn't move smoothly. Instead, it moves with a stick-slip movement. This is due to the fact that there is adhesion friction (coefficient μ_{ad}) and sliding friction (coefficient μ_{sl}). In a contact surface, sliding friction is always lower than adhesion friction.

In good conditions $\mu_{ad} = 0,15$ to $0,25$ and $\mu_{sl} = 0,08$ to $0,15$. If we take, for example, $\mu_{sl} = 0,12$ and $\mu_{ad} = 0,20$ on a drying cylinder weighing 15 tons, it would mean that the bearing on the front side will not move until the axial load created by the thermal expansion reaches $(15/2 \times 0,20) = 1,5$ tons. Then the bearing moves axially, but stops as soon as the axial load gets below $(15/2 \times 0,12) = 0,90$ tons. If thermal expansion continues, the axial load will increase again. There can be several stick-slip movements and at the end the bearings will be loaded with an axial residual load between 0,90 and 1,2 tons. While this is the case where surfaces are in good condition, in reality, fretting corrosion and oil ageing lead to higher sliding and adhesion friction coefficient which can even be above 0,40.

Quite often, when calculating the nominal life of a drying cylinder bearing most people consider zero axial loads. However, as shown above, an axial load exists and because the spherical roller bearing isn't a thrust bearing, it will have a strong influence on bearing life. For a 23052 CCK/C4W33, an axial load equal to 15% of the radial load reduces the calculated basic rating life by 70%. If the axial load is equal to 40% of the radial load, the calculated basic rating life is reduced by 96%. This is one of the reasons why paper machine manufacturers' design departments used to, and sometimes still do, request a basic rating life over $L_{10h} = 200\ 000$ hours.

SKF doesn't recommend this bearing assembly solution for the front side of drying cylinders on machines with wire widths above 4 500 mm. Personally, I don't recommend it for any drying cylinder, but for cost reasons on older machines, I can understand using it.

With a bearing housing on three rockers and the bearing axially located in the housing, axial displacement is accommodated by the axial displacement of the housing on the rockers. The shape of the rockers allows the housing to always be at the same height (→ fig. 10 and 11)

For Yankee cylinders there can be the need to have additional rockers on the side since the press and/or suction press roll push the Yankee cylinder radially. Side rockers are necessary if the resultant

radial load on the cylinder diverges more than 30° from the vertical downward position (→ fig. 12)

The bearing used can be a standard SKF bearing due to our heat treatment, but the housing is quite expensive. The bearing has to withstand very low axial loads which are neglected in life calculations. In addition, there's no need for a very loose fit between bearing outer ring and housing. Since the bearing outer ring doesn't axially displace in the housing, fretting corrosion is less pronounced and has less influence on bearing life. This was previously the best solution and accordingly recommended by SKF for paper machines with a wire width above 4500 mm. However, this housing arrangement is rather unstable and does not damp vibration as well as solid housings. This may be a problem when upgrading to higher speeds. This arrangement is also sensitive to tilting forces from rope sheaves and steam joints fastened on housings, for instance.

Fig. 10 Rockers ensure that a drying cylinder housing is always at the same height.

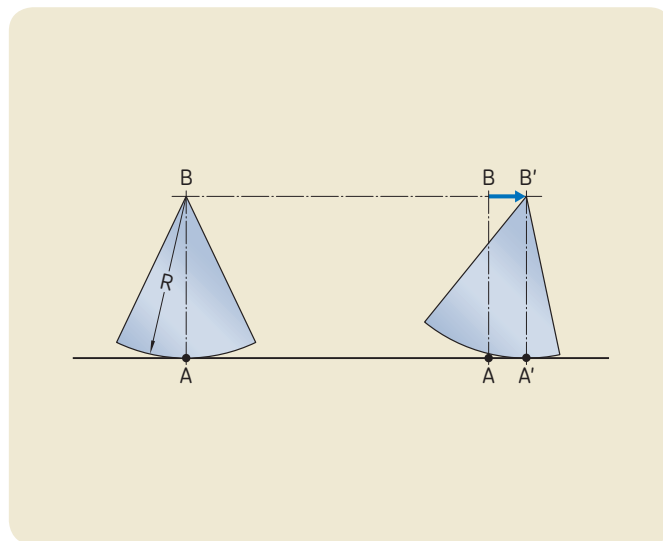
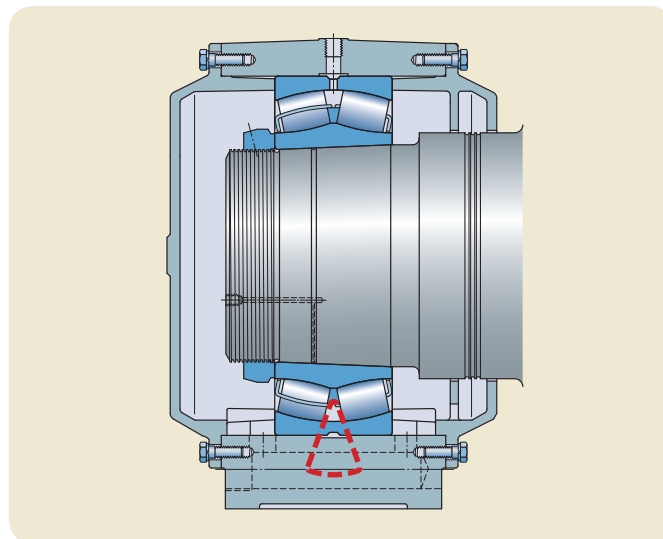

Fig. 11 Spherical roller bearing in a drying cylinder housing supported by rockers.



Rockers do wear out and will need to be changed after some time. When a rocker wears, the housing stands lower. I've seen housings as much as 3 mm lower than their original position due to rocker wear. On the rocker contact surface with the base, wear creates a flat zone and there is a need for more axial load to make them tilt to let the housing move axially. In addition, some rocker housing designs don't have any features to stop the housing from jumping off the rockers. I've seen a case where a paper jam lifted the housing on the front side and the drying cylinder fell damaging the drive side, felt and felt rolls.

Many customers modify their housings to upgrade to CARB by converting rocker housings to fixed housings (→ **fig. 13** and **14**).

Moving on to cylindrical roller bearings, the idea to use them is a good one since there will be no axial residual load due to thermal expansion of the drying cylinder. Also, with the bearing outer ring located in the housing, without a too loose fit, fretting corrosion is small. Furthermore, rocker housings aren't needed, of course. However, standard cylindrical roller bearings do not have adequate heat

treatment and wouldn't withstand the misalignment that could easily be found in the drying cylinder application. As such, a special cylindrical roller bearing was created. The SKF version, old suffix 342460 or VA701, had a case hardened inner ring and a special roller profile to withstand up to 7 minutes misalignment. An example of an arrangement using such a bearing is shown in **fig. 15**. The bearing designation could, for example, be N 3040 K/C4VA701.

Mounting such a bearing is a special and time consuming procedure using a dial gauge and a special dial gauge support to check misalignment (→ **fig. 16**). Then, depending on dimension D_o and the dial gauge reading S , the misalignment was found with the help of a diagram.

Unfortunately, misalignment was rarely checked after the initial mounting and most of the bearings suffered from too high misalignment due to frame deformation or the foundations settling over time. Given this, and because these bearings can be replaced – without any modification – by CARB, SKF has stopped making them. Nevertheless, there are still a few machines running with such bearings.

Self-aligning double row cylindrical roller bearings are also sometimes used. The idea is to keep the advantages of the cylindrical roll-

Fig. 12 Yankee cylinder bearing housing with side rockers, front side

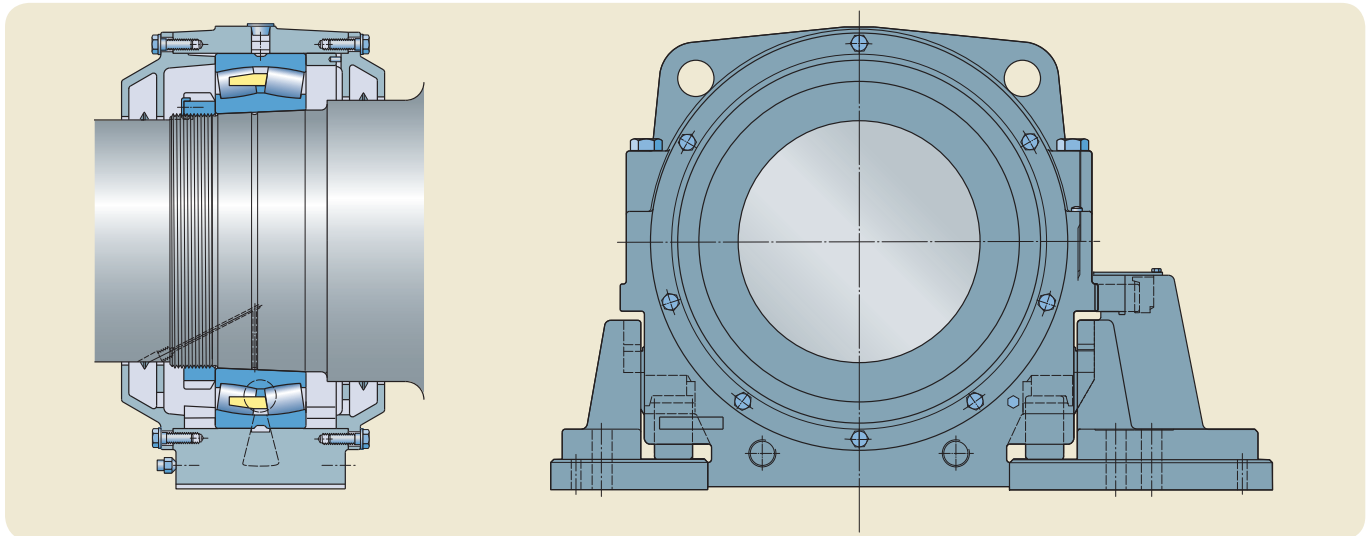

Fig. 13 Rocker housing before modification.



Fig. 14 Rocker housing converted to a fixed housing by SKF.



er bearing, but without the misalignment issue. The misalignment is taken by the outer ring which is, in fact, a spherical plain bearing (→ fig. 17)

To be able to have a spherical plain bearing and a cylindrical roller bearing with ISO bearing dimensions, the rollers need to have a small diameter. As such, load carrying capacity is much lower than a spherical roller bearing with the same dimensions. Compared with a spherical roller bearing that slides in its housing, thus having to withstand axial load, the lower load capacity of the self-aligning double row cylindrical bearing isn't an issue, since the bearing has only radial load. That's the theory. In reality, the bearing has radial load and some moment load due to misalignment. Furthermore, there is always some friction in the spherical plain bearing part. The bearing will then misalign when loaded with a stick-slip movement. Thus, the cylindrical roller part will always have to withstand some misalignment. The internal stress due to misalignment will be low when a new bearing is mounted but, as time passes, the friction in the plain bearing part will increase due to oil ageing and fretting corrosion. The internal stress due to misalignment will increase with time thereby reducing the service life of the cylindrical roller bearing part. SKF has experience with these bearings since we used to make them for the metal working industry. Today, SKF recommends CARB as this has proven to be the most reliable solution.

CARB is the acronym for Compact Aligning Roller Bearing. It's an SKF single row toroidal roller bearing that accommodates up to 0.5° misalignment without much influence on its life and which is able to accept axial displacement like a cylindrical roller bearing (→ fig. 18).

While 0.5° misalignment might sound small, it equates to 8,7 mm deviation at one metre and you can surely align a bearing much better than this, even with the naked eye. Besides which, with such misalignment, there would be machine, seal or paper quality issues long before you had a bearing problem.

Using CARB means that the misalignment problems that can occur with cylindrical roller bearings or self-aligning double row cylinder roller bearings are a thing of the past. When the cylinder expands due to temperature, CARB - like the cylindrical roller bearing - doesn't take any axial load. No stick-slip movement, no residual axial load, just smooth axial thermal expansion. The outer ring is

located axially in the housing and the tolerance fit doesn't need to be very loose, just loose enough so that the bearing can be pushed with ease in the housing during mounting.

A typical CARB and SKF housing arrangement is shown in fig. 19. With no rockers and the housing firmly bolted to the machine frame, vibrations are damped. CARB was first mounted on a paper machine in 1994, as a replacement for spherical roller bearings in rocker housings, on PM51 at Holmen Paper's Braviken mill. Vibration in the axial direction was reduced by up to 85%.

The advantages of CARB on the drying cylinder front side position were so obvious that SKF focused in the beginning on that application. It is now a well accepted solution by the major paper machine OEMs.

Customers must be aware that the internal radial clearance of CARB decreases when the inner ring axially displaces relatively to the outer ring. An axial displacement of 5% of the bearing width gives a very small radial clearance reduction which can be considered as negligible. For example a C 3152 K/C4, the most popular size on modern paper machines, has a width of 144 mm. Bearing

Fig. 16 Procedure to check alignment for 342460 or VA701 suffix bearings.

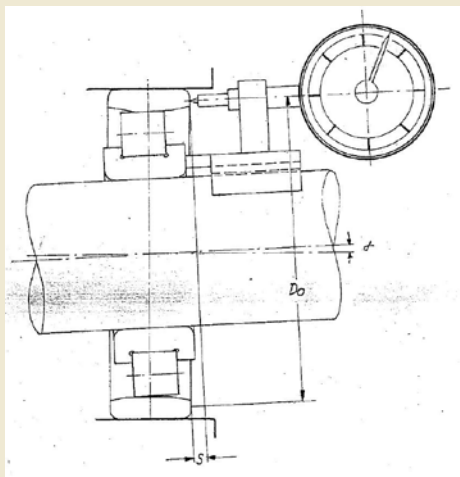

Fig. 15 VA701 cylindrical roller bearing used as front side drying cylinder bearing.

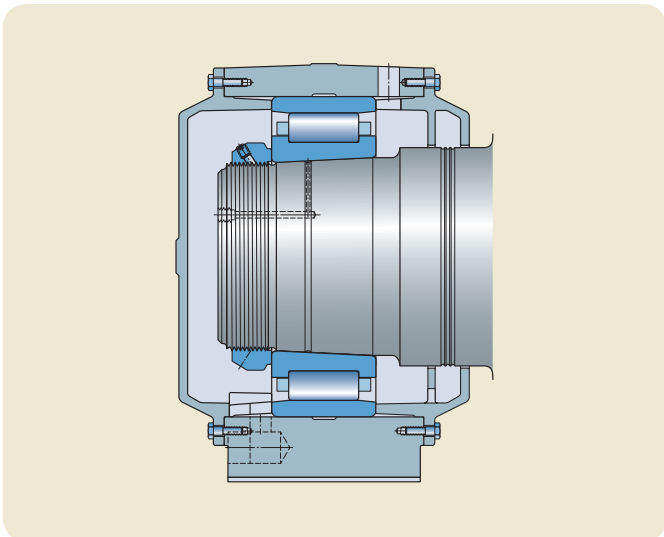
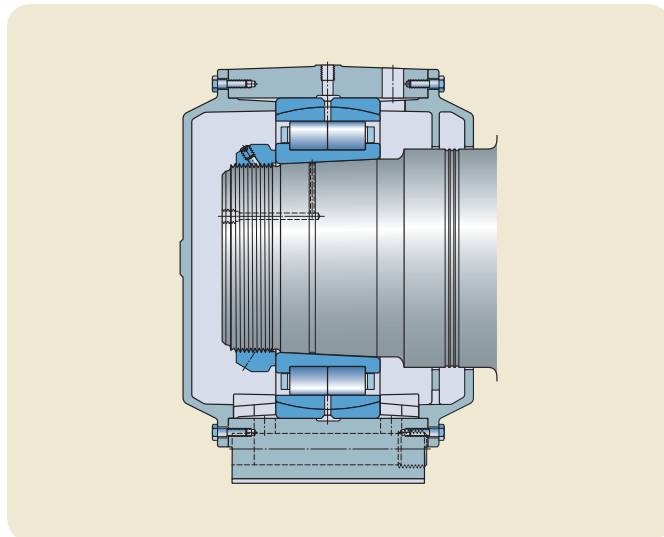

Fig. 17 Self-aligning double row cylindrical roller bearing assembly.



clearance before mounting is between 0,444 and 0,556 mm. An inner ring axial displacement of $0,05 \times 144 = 5,7$ mm gives a radial clearance reduction of 0,027 mm. Further, axial displacement increases the clearance reduction rapidly. For more information I recommend reading the CARB chapter in the SKF General Catalogue, or on the online catalogue on www.skf.com, where you will find graphs and formulas.

In the majority of applications like fans, gearboxes, felt rolls and press rolls, the inner and outer ring can be aligned by eye and you can just let the CARB do the job. For drying cylinders, I would recommend following the guideline given in **fig. 20**.

This concludes the first part of my coverage of bearings in drying and Yankee cylinder applications, but the next issue of SKF Pulp and Paper Practices will also focus on them. In it, I will cover heat treatment for bearing steel, guidelines for choosing appropriate bearing internal clearance class plus information on selecting suitable paper machine oils and flow rates.

Philippe Gachet is an SKF application engineer who has been working with the heavy industries, particularly pulp and paper, since 1990. He can be contacted at philippe.gachet@skf.com



Fig. 18 CARB accommodates misalignment and axial displacement.

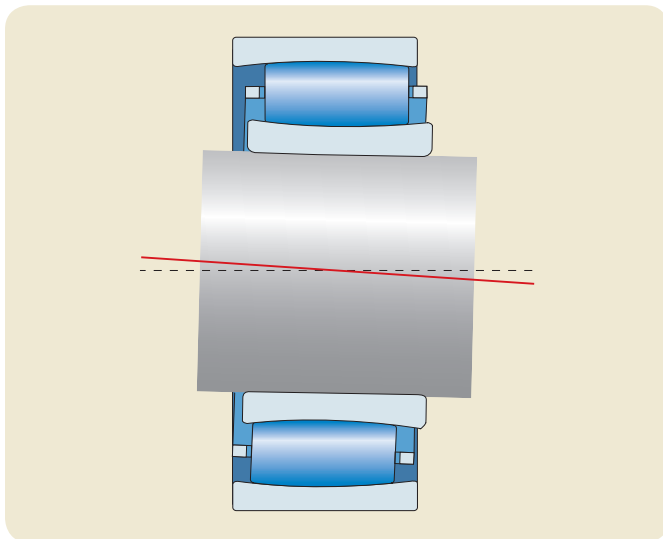

Fig. 19 CARB in an SKF SBPN drying cylinder housing.

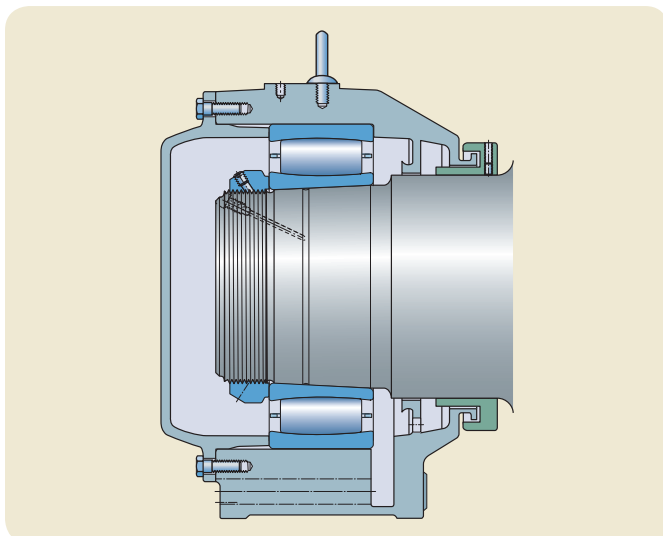
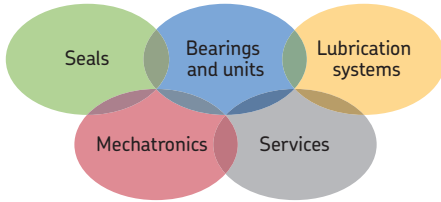

Fig. 20 Axial inner ring/outer ring offset when a paper machine is cold.

Cylinder length		Steam temperature	Initial axial displacement
over	incl.		
m		°C	mm
0	4	<160	0±1
0	4	160 – 200	2 – 4
4	7	<160	2 – 4
4	7	160 – 200	4 – 6
7	11	<160	4 – 6
7	11	160 – 200	6 – 8



The Power of Knowledge Engineering

Drawing on five areas of competence and application-specific expertise amassed over more than 100 years, SKF brings innovative solutions to OEMs and production facilities in every major industry world-wide. These five competence areas include bearings and units, seals, lubrication systems, mechatronics (combining mechanics and electronics into intelligent systems), and a wide range of services, from 3-D computer modelling to advanced condition monitoring and reliability and asset management systems. A global presence provides SKF customers uniform quality standards and worldwide product availability.

SKF Global Pulp & Paper
Segment

Contact/Responsible editor
philippe.gachet@skf.com

© SKF and CARB are registered trademarks of the SKF Group.

© SKF Group 2012

The contents of this publication are the copyright of the publisher and may not be reproduced (even extracts) unless prior written permission is granted. Every care has been taken to ensure the accuracy of the information contained in this publication but no liability can be accepted for any loss or damage whether direct, indirect or consequential arising out of the use of the information contained herein.

PUB 72/59 11147/5 EN · September 2012

Certain images used under license from Shutterstock.com.



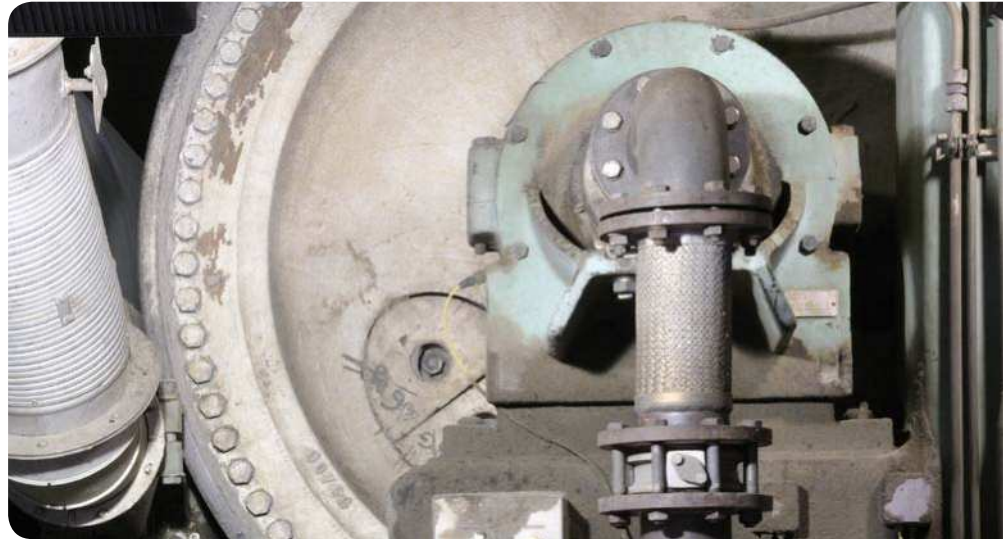

I do not want to be called an "expert"

"After 22 years of working as an SKF engineer with the paper industry, I'm still in learning mode. That said I have developed some principles during this time that help me with both my professional and personal life".

My first principle is that 'just because it has always done that way doesn't mean it is a good way to do it.' My second is based on a quote from Gandhi: "An error does not become truth by reason of multiplied propagation, nor does truth become error because nobody sees it." My third and final principle is that 'by illuminating the past, the present becomes clearer.'

Years ago, I remember having to supervise the mounting of some drying cylinder bearings. The fitters were from an out-sourced maintenance company. Some of them had been bakers the week before! In charge of the team was an older man who they all called "boss". The boss explained to his team how to use feeler gauges to check bearing clearance and how to mount bearings on tapered seats. He told them to reduce the bearing clearance to the minimum permissible residual clearance value.

Not wanting to contradict the boss in front of his team, I waited until we were alone to explain that he shouldn't aim for minimum permissible residual clearance as it could lead to premature failures – even maybe leading to cracked inner rings – especially for drying cylinder bearings with C4 or C5 clearance class.

The boss explained to me that he had worked for more than 20 years for a crane manufacturer, that he had always mounted spherical roller bearings in this way and that he had never had any complaints. He had little time for the young SKF engineer, fresh out of college, who told him that crane bearings weren't C4 clearance and the risk was much lower of getting too tight a fit.

The boss later retired. He became a bearing mounting trainer and taught people his way of doing things. The bearing catalogue didn't warn readers about minimum permissible radial clearance and that it could be easily misunderstood. So, error became truth for a while.

These days, you won't find information about minimum permissible radial clearance in new SKF bearing catalogues. We learned and we've taken it away. Nevertheless, ever since that day I'm never entirely comfortable when a colleague introduces me as an expert.

Regards,
Philippe Gachet
Senior technical consultant
Philippe.gachet@skf.com



Drying and Yankee cylinder bearings and their lubrication (Part II)

In this edition of SKF Pulp & Paper Practices I will continue my coverage of drying and Yankee cylinder bearings that I started in the previous issue. Given this, I recommend that you read issue six again to refresh your memory.

As promised last time, I'll address a number of important topics in this issue: bearing steel and heat treatment, bearing clearance class, oil selection and oil flow rates.

Bearing steel and heat treatment

As we saw in the previous issue, the inner rings of bearings in drying and Yankee cylinder applications have to withstand high hoop stress especially during machine start-up. This can crack them though the risk is higher with certain steel types and heat treatment methods than with others.

Consider first martensitic through-hardened steel. The vast majority of bearings that are made use this as it provides adequate hardness at comparatively low cost. Unfortunately, there are residual tensile stresses near the surface in such steel. This is because the structure of steel changes during the heat treatment and its volume increases as it cools, but the surface cools quicker than the core. This leads to a situation where the core needs to increase in volume while the surface is already hard and cannot deform. This creates tensile stresses near the surface where micro cracks can develop due to classic fatigue or surface-initiated fatigue. If there is a very tight fit of the bearing on its seat or – like in drying cylinder applications – the seat is much hotter than the inner ring, tensile stress near the surface is increased.

Take the example of a drying cylinder bearing made from martensitic steel with a residual tensile stress near the surface of 80 MPa (11 600 psi). Assume that a tight fit leads to a hoop stress of 50 MPa (7250 psi) and that thermal radial shaft expansion due to the steam adds another 50 MPa (7 250 psi) stress in the ring. This adds up to 180 MPa (26 100 psi) total tensile stress which is slightly above the 175 MPa (25 375 psi) maximum that we recommend for through-hardened rings. While 175 MPa (25 375 psi) is not an absolute maximum since new bearings without any surface damage can withstand more, it is a practical maximum based on field experience where, as we know, rings don't stay in brand new condition for ever.

Compare the example above with bainitic through-hardened or case-hardened steel which have residual compressive stresses near the surface after heat treatment. With premium bainite bearing steel, for instance, with compressive stresses of say 125 MPa (18 125 psi), the total stress – assuming the same conditions – is 25 MPa (3 625 psi) compressive. This is why micro cracks in the subsurface propagate more slowly in such steels and why they are more crack resistant.

Be aware, however, that not all bainitic steel is created equal. Take, for example, the last two generations of SKF bainitic through-hardened steel used in our spherical roller bearings, CARB and spherical roller thrust bearings. While the residual compressive stresses are more or less the same, the latest generation has four times more grains per unit of area and a finer structure. As such, the crack resistance is much higher than with the previous generation. You can read more about this, if you're interested, in issue four of SKF Pulp & Paper Practices.

Case-hardened steels, because they have a soft core, are difficult – though not impossible – to crack. While I have never come across an SKF case-hardened spherical roller bearing mounted on a Yankee or drying cylinder with a cracked inner ring, I have seen it on bearings from some other manufacturers. Another thing worth remembering about case-hardened bearings is that they do not necessarily reduce the risk of surface damage or subsurface fatigue. In fact, some have lower fatigue resistance than modern through-hardened bainite steels.

Another important issue is heat stabilization. The SKF bearings used in Yankee and drying cylinder applications are heat stabilized to 200°C (392°F). This does not mean that there will not be any dimensional changes due to temperature. Rather it means that such changes are limited and acceptable. Acceptable to SKF means changes within the following boundaries:

Metric:

0 to +10 µm/100 mm with 150 °C stabilisation at 150 °C during 2,500 hours

–15 to +5 µm/100 mm with 200 °C stabilisation at 200 °C during 2 500 hours

Imperial:

0 to +0.0254 in /10 in with 302 °F stabilisation at 302 °F during 2 500 hours

–0.0381 in to +0.0127 in /10 in with 392 °F stabilisation at 392 °F during 2 500 hours

Martensitic steel bearings with low (100–120 °C or 212–248 °F) heat stabilization will expand after a relatively short time running at 120 °C (248 °F). Years ago, when such bearings used to be mounted on drying cylinders, many lost their inner ring tight fit and sometimes rotated on the journal leading to wear. This led to maintenance staff increasing the drive-up along the taper seat to achieve a tighter fit thereby increasing the tensile stress and the incidence of cracked inner rings.

Let's consider the example of a spherical roller bearing, 23052 CCK/CW33, on a drying cylinder with no insulation and a steam temperature of 130 °C (266 °F). Inner ring dimensional changes will vary significantly depending on the steel used and the level of heat stabilization (see **figure 1**)

Considering residual stress, crack resistance and dimensional stability, you could conclude that bearings for drying and Yankee cylinder applications should be stabilized to 200°C (392°F) and case-hardened. In reality, things are not that clear cut.

60 years ago, SKF in Sweden proposed bainitic through-hardened bearings – heat stabilised to 200 °C (392°F) – for drying and Yankee cylinder applications. They became standard for this duty and later for all SKF spherical roller bearings made in Sweden. In contrast, SKF in the USA kept martensitic through-hardened bearings as standard and offered bearings with case-hardened inner rings for dryers and Yankees.

As a consequence, for several decades most European-designed paper machines used spherical roller bearings made from bainitic steel while those designed in the USA used martensitic bearings and case-hardened bearings for heated cylinders in the dryer section. To further complicate matters, some Beloit machines were designed by European subsidiaries and used bainitic steel bearings plus SKF Sweden had the capability to offer case-hardened bearings if requested by the customer.

For consistency, and because European machines were often sold to markets that favoured case-hardened bearings, SKF began recommending bearings with case-hardened inner rings for heated cylinders in the early 1990s. Many customers were satisfied with the standard bainitic steel and didn't change over, but some did.

So much for the history lesson, but times and technology move on. Based on our latest heat treatment developments and the installed base of paper machines with SKF standard bearings in their dryer sections, we updated our recommendations at the end of 2010.

So, what are SKF's current recommendations? Quite simply:

- 1 If the journals are insulated, bearings with case-hardened inner rings are not needed and standard SKF spherical roller bearings and CARB can be used.
- 2 If the journals are not insulated, standard SKF spherical roller bearings and CARB can be used if steam temperatures are below 170 °C (8.35 bars) or 338 °F (121 PSI). Otherwise, bearings with case-hardened inner ring should be fitted.

In SKF, spherical roller bearings and CARB bearings with case hardened inner ring are denoted by the suffix HA3. The exception is for SKF spherical roller bearings made in the USA which have the prefix ECB.

Example of 23040 bearing with a tapered bore and C4 clearance class:

- 23040 CCK/C4W33 (standard bainitic through-hardened steel)
- 23040 CCK/HA3C4W33 or ECB 23040 CCK/C4W33 (bearing with case-hardened inner ring)

One final word of warning - be careful if you speed up your old, uninsulated drying cylinders and increase the steam temperature above 170 °C at the same time. This could lead to problems unless you have suitable bearings mounted.

Fig. 1 – Inner ring dimensional expansion in µm/100 mm (inch/10 inch).

Operating time	Martensitic steel dimensionally stabilised at 120°C (248°F)	Martensitic steel dimensionally stabilised at 200°C (392°F)	SQS Salt Quench Martensitic steel dimensionally stabilised at 200°C (392°F)	SKF bainitic new steel dimensionally stabilised at 200°C (392°F)
10 000 hours	17 (0.0432)	5 (0.0127)	0,07 (0.0002)	0,05 (0.0001)
100 000 hours	70 (0.1778)	13 (0.0330)	0,31 (0.0008)	0,35 (0.0009)

Clearance class

If we disassemble a drying cylinder bearing and look at the operating marks on the outer ring raceway, we can see that the load zone is often around one-third of the circumference. This shows that the bearing has operated with more clearance than needed and that the load distribution is not optimised for the longest fatigue life. As we know, a slight preload is better if we want to achieve that (see **figure 2**)

The clearance needs, however, to be sufficient to avoid excessive preload during start up from cold when, because of the steam passing through the journal bore, there is a large difference between the temperature of the bearing inner ring and outer ring and a subsequent clearance reduction. The consequence is a smaller loaded zone once the machine has reached its steady state operating temperature.

Theoretically, a small preload is not a concern as it increases the fatigue life, but we should not forget that friction rises and consequently preload can increase - sometimes in an uncontrolled way - with a risk of jammed bearings. Furthermore, other things need to be considered:

- 1 Possible form errors of the housing and the journal
- 2 The mounting method used to get the right fit

The feeler gauge method is still widely used for mounting which can lead to a wide range of clearance reduction. In addition, incorrect mounting is relatively common with fitters trying to reach the minimum residual recommended clearance shown in old bearing catalogues. For drying cylinders, this results in too much clearance reduction.

All things considered, it is not a problem to play it safe and have more operating clearance than is needed in these applications because drying and Yankee cylinders are generally oversized.

Over the years, C4 clearance class has become industry standard for drying and Yankee cylinders though C3 clearance is optimal in some cases. However, for cases with no journal insulation and steam temperatures greater than 165–170 °C (320–338 °F), we recommend C5 clearance.

Before moving on to talk about lubrication, there are a few things that I need to say about bearing selection. Initially, I didn't want to cover it as there is a lot of confusion about bearing life and because it really needs an article of its own but, on reflection, there are four points that I should make.

One, for the load calculation the mass of the cylinder and press load on the Yankee are always taken into account, but loads created by felt tension and the water inside the cylinder are often forgotten.

Two, it is generally accepted that the basic rating life (L10h), which only takes into account load and rotational speed, should be above 200 000 hours for drying and Yankee cylinder bearings. This is an old guideline and is longer than the bearings in other paper machine applications. It leads to oversized bearings and made sense in the old days to compensate for inadequate lubrica-

Fig. 2 – The influence of internal bearing clearance on fatigue life and friction.

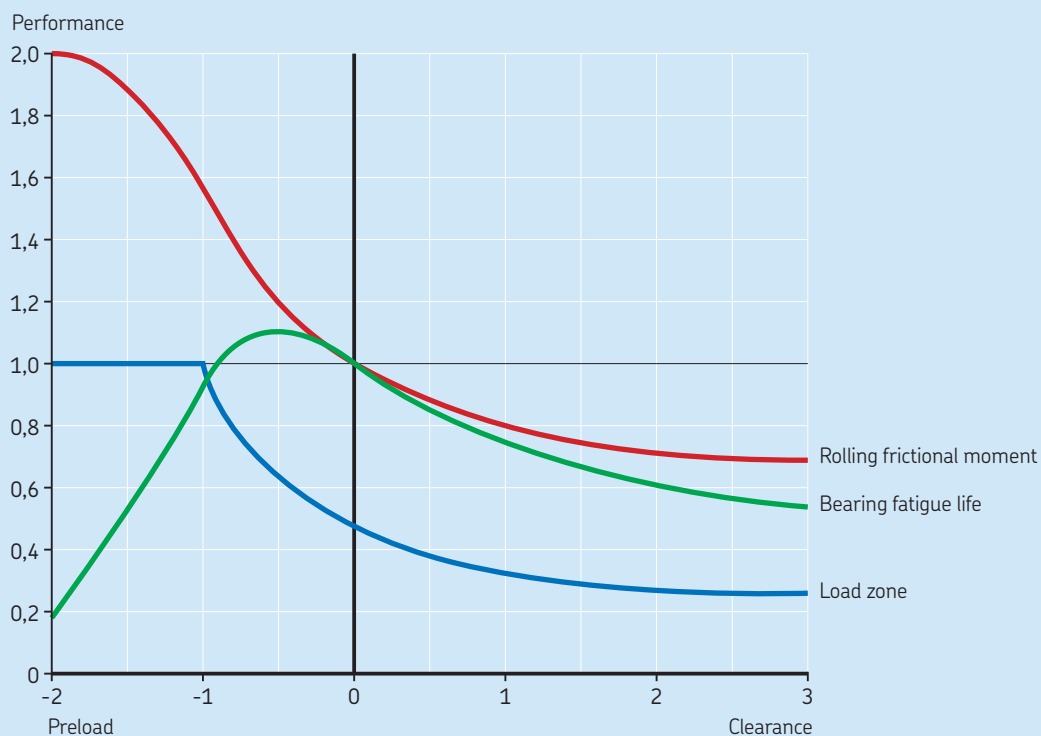

tion and contamination. Today, the SKF rating life (L10mh) - which takes account of solid contamination (oil filter efficiency), surface separation in the rolling contact (the viscosity ratio) and the fatigue load limit of the material – allows a more realistic life to be calculated. However, the industry has not reached agreement on what the SKF rating life should be. Some manufacturers say that above 100 000 hours is fine, but others stick with the old 200 000 hour life. My personal view is that L10mh should be above 100 000 hours and that water content should be kept below 200 ppm with 500 ppm allowable during operation only.

Three, water content in the oil and its influence are not taken into account when calculating rating life. Dissolved water has an influence on bearing life, but different studies show different results. As no consistent results exist, it is not included in any rating life calculation.

Four, calculated rating life is not service life. Calculated rating life is used to choose a bearing for an application whereas the service life is the actual life of a bearing in an application. Individual bearing life can only be calculated statistically and life calculation only refers to a population of bearings with a given degree of reliability. Besides which, bearing failures in drying and Yankee cylinders are not generally the result of normal fatigue, they are mainly due to corrosion and inadequate lubrication.

Lubrication

Grease, oil bath and oil drop lubrication are not recommended for drying and Yankee cylinders. Quite simply, SKF recommends circulating oil lubrication on modern machines to maximize reliability.

In some cases, the same oil is used to lubricate the bearings used in the drying cylinders, the vacuum rolls, the felt rolls and the integrated gears. This is a compromise as suitable oils for gears and drying cylinders have different characteristics. Gears oils need EP additives which we don't recommend for drying cylinder applications.

With regards to Yankee cylinders, SKF recommends separate lubrication systems for the Yankee bearings, the external drive gearbox and the suction press or press roll. These are quite different applications and it is better to lubricate each with oils with suitable properties. Such an approach also prevents cross-contamination. For example, oil lubricating the suction press roll could be contaminated with water and the EP additives needed for gears which accelerate oil ageing and reduce bearing life drastically.

Let's move on to look at lubrication in more depth, but please note that what follows is applicable to drying and Yankee cylinder bearings only.

Oil flow and oil viscosity

Clearly, a certain oil flow rate is needed to cool dryer section bearings and ensure that the oil in the rolling contact has sufficient viscosity to create an adequate film thickness.

SKF uses the κ value (kappa) as an indicator of the surface separation in the rolling contact. It is a viscosity ratio.

$$\kappa = v/v_1$$

With

κ = viscosity ratio

v = real operating viscosity of the oil, in mm²/s, at the bearing operating temperature

v_1 = rated viscosity depending on the bearing mean diameter and rotational speed, in mm²/s.

The SKF General Catalogue shows that the rated viscosity is the minimum viscosity with adequate lubrication in the rolling contact and also how to calculate it. The higher the value of κ , the better the surface separation. For κ above 4, the surfaces are completely separated.

As general guideline for paper machines, SKF recommends a κ value between 2 and 4. In the case of drying and Yankee cylinders, due to the high operating temperature and the relative low rotational speed of the bearings, most drying and Yankee cylinder bearings operate with κ below 1. Sometimes it can even be below 0.2 which results in boundary lubrication with surface distress and/or abrasive wear. This is especially true for old machines where the journals are not insulated. These old machines often run above design speed with increased steam temperature. For machines with uninsulated journals, old circulating oil systems and steam temperatures above 170 °C (338 °C) it's not uncommon for mills to complain about low bearing service life, cooked oil and oil leakage above certain oil flow rates.

The oil flow and oil viscosity will be chosen based on a κ calculation. SKF uses proprietary software called Drycyl to do this. Comparisons between calculations and measurements done by a leading paper machine manufacturer showed a high level accuracy with it.

As bearing temperature is mainly influenced by the steam temperature, the influence of the load can be ignored. The information needed is:

- 1 Bearing reference
- 2 Rotational speed
- 3 Steam temperature
- 4 Oil inlet temperature
- 5 The degree of insulation i.e. no insulation, bore only insulated or bore and journal end face insulated.
- 6 Whether saturated steam or superheated steam is used in for cases where there is no insulation.

Let's take an example:

- Bearing: 23148 CCK/C4W33
- Speed: 200 rpm
- Steam temperature (saturated): 177 °C (350 °F)
- Oil inlet temperature: 55 °C (130 °F)
- Oil: ISO VG 220 (the most common oil viscosity class in dryer sections)

Firstly, for a journal with no insulation, it can be seen that the κ value is below one even with high flow rates (see **figure 3**).

The first improvement could be to decrease the oil inlet temperature, but this means risking condensation in the bearing housing. Also, when the journal isn't insulated, decreasing the oil inlet temperature by 5 to 10 °C (9 to 18 °F) only has a small influence on the bearing temperature. Alternatively, we could try

increasing the oil viscosity class from ISO VG 220 to a ISO VG 460 for instance (see **figure 4**).

The higher viscosity means there will be more friction in the bearing and its temperature will increase. Even if we selected oil with twice the viscosity, the increased viscosity at bearing operating temperature is less than 40% in this case. Furthermore, the risks of leakage due to flow resistance in the return ducts and pipes are increased which may mean the oil circulating system would have to be modified. So, let's try keeping the ISO VG 220 oil and good insulation on the bore and end face of the journal instead (see **figure 5**)

As you can see, just by good journal insulation we can achieve the κ value recommendations from the SKF General Catalogue with an oil flow just above 3 l/min (0.79 US gal/min).

That said, experience shows that many drying and Yankee cylinder bearing operate with κ values below 1 even if it doesn't follow SKF's general recommendations. So, based on field experience, SKF created a κ_{min} concept which is only valid for paper machines. κ_{min} is the minimum κ value above which experience shows that service life was still satisfactory.

$$\kappa_{min} = n \cdot d_m / 80000$$

n = bearing rotational speed

d_m = bearing mean diameter (bore diameter + outer diameter, then divided by two).

If the formula gives a value below 0.25, then $\kappa_{min} = 0.25$.

In our example:

- Bore diameter of the bearing: 240 mm
- Outer diameter: 400 mm
- Speed: 200 rpm

$$\kappa_{min} = [200 \times (240 + 400) / 2] / 80000 = 0.80$$

In this case, the journal needs to be insulated to reach a κ above 0.80. I would recommend, for this example, an oil flow between 3 and 3.5 l/min (0.79 and 0.92 USgal/min) with an alarm if the oil flow drops below 2 l/min (0.53 US gal/min). Another SKF engineer

Fig. 3 – Journal with no insulation (1 litre = 0.2642 US gallon).

Result			
Oil flow	Viscosity ratio κ	Viscosity	Bearing temperature
l/ min		mm ² /s	°C
0,5	0,27	8,2	136
1,0	0,31	9,3	130
2,0	0,35	10,8	123
3,0	0,38	11,5	120
5,0	0,40	12,0	118
10	0,41	12,3	117

Fig. 4 – Journal with no insulation and increased oil viscosity (1 litre = 0.2642 US gallon)

Result			
Oil flow	Viscosity ratio κ	Viscosity	Bearing temperature
l/ min		mm ² /s	°C
0,5	0,37	11,2	141
1,0	0,42	12,7	135
2,0	0,48	14,6	128
3,0	0,52	15,7	126
5,0	0,54	16,4	124
10,0	0,55	16,8	123

Fig. 5 – Journal with insulation (1 litre = 0.2642 US gallon)

Result			
Oil flow	Viscosity ratio κ	Viscosity	Bearing temperature
l/ min		mm ² /s	°C
0,5	0,67	20,4	98
1,0	0,81	24,7	91
2,0	0,95	28,8	87
3,0	0,99	30,2	85
5,0	1,03	31,3	84
10,0	1,03	31,3	84

could give slightly different recommendations based on the above calculations

A question that I'm often asked by mills experiencing oil leakage through housing seals due to flow resistance in the ducts and return pipes is to what extent oil flow can be reduced. One point to consider is that as the κ value drops when the oil flow is reduced, so the limit would be when the oil flow reaches the κ_{\min} value. Another point is the limit under which there isn't enough oil in the bearing. This limit isn't very well documented and depends on many things. So, to make it simple and conservative, you can use the rule of thumb below.

Minimum oil flow = 0.00002 DB.

D = bearing outside diameter (mm)

B = bearing width (mm)

For a 23148 CCK/C4W33 bearing the minimum oil flow would be $0,00002 \times 400 \times 128 = 1,02$ l/min. So, in the example, an oil flow giving the κ_{\min} is just below 1 l/min (see **figure 5**) and the minimum oil flow is just above 1 l/min. So giving 1 l/min as lower limit seems adequate, but it doesn't change my recommendation for the above example.

If a customer has oil leakage at 1.5 l/min (0.40 USgal/min) and there is a need to have 3 l/min (0.79 US gal/min) to be above κ_{\min} there is a problem. Either the oil return pipes were not dimensioned for 3 l/min (0.79 US gal/min) at that oil viscosity (which happens with old machines when the steam temperature is increased) or they got contaminated by aged black oil sludge. This reminds me of a customer who tried to use diesel engine oil as a lubricant hoping that the detergent additives would clean his circulating oil system. Also of another customer who made a mixture of white spirit and trichloroethylene and circulated it through his system during a shutdown. In most cases, the really effective solution is to change the oil return pipes.

Another issue is the oil flow when a machine starts. Cold oil or heated oil cooled by passing through cold inlet pipes has too high viscosity. Please take another look at John Yolton's story in SKF Pulp & Paper Practices 2 as there is a solution to this issue.

Note that the lower is the κ value, the more important the filtration efficiency.

- Filter rating $\beta_{12}=75$ is a minimum
- Filter rating $\beta_6=200$ is average today on paper machines, it was considered a very good filtration efficiency more than 20 years ago when I started at SKF.
- Filter rating $\beta_3=1000$ is state of the art.

Which oil?

Well, let me start by saying that SKF does not recommend a specific brand or oil and that we used to simply leave the customers and the oil suppliers to choose lubricants. This changed after a spate of drying and Yankee cylinder bearing failures in the 1980s that studies indicated were related to inadequate oil formulations.

SKF and a leading European paper machine manufacturer worked closely to solve the issue and in 1988 SKF proposed a set of tests to validate oils for paper machine dryer sections. For practicality, only simple and/or well known tests that could be performed in a standard laboratory were chosen. Many oils that were marketed for paper machine dryer sections failed.

As a result, SKF concluded that the important properties for dryer section oils are:

- Thermal and chemical stability
- Stable viscosity
- Corrosion protection
- Water separation ability
- Cleanliness

Fig. 6 SKF roller test (new rollers on the left). Rollers are placed in oil and put in an oven for 8 weeks. This test gives information on chemical corrosion and deposit formation. The oils tested are suitable in the case of the two middle rollers, but unsuitable for the two on the right.



Thermal and chemical stability tests are critical. Oil for the dryer section has to prevent or reduce deposit formation in oil circulation, oil supply systems and rolling bearings. Even after long thermal stressing, the lubricating oil or the ageing products that are formed must not corrode rolling bearing parts chemically. Incipient etching, deposits or incrustation (crack products) interfere with lubrication and will ultimately damage the surface of the rolling contact.

As it ages, oil is darkened by finely suspended matter from oil, coal and cracked products and, as a result, flow meters and flow sight glasses clog or no longer indicate the oil flow correctly. (See **figures 6 and 7**)

Thin oil films must not resinify or form lacquer under thermal stress (see **figure 8**) as this may impair the lubrication system by clogging the oil supply lines or sight glasses. If brass cages are used in the rolling bearings and/or machine parts are made from copper or brass, the oil must not oxidise or corrode these non-ferrous metals.

Fig. 7 Two different mineral oils after 8 weeks at 120 °C (248 °F). The oil on the left is suitable while the one on the right is unsuitable.



Fig. 8 SKF oil ageing test. On the left is synthetic oil after four weeks at 140 °C (284 °F), it has lacquered and the evaporation loss is 93%. On the right is a mineral oil after 4 weeks at 120 °C (248 °F) with an evaporation loss of only 2%.



Thermal and chemical stability tests are undertaken at 120 °C (248 °F) and 140 °C (284 °F). In cases where bearing operating temperature is above 120 °C (248 °F), the results at 140 °C (284 °F) must be taken in account. For example, on a modern machine with insulated journals and where bearing operated at a temperature below 100 °C (212 °F), the results at 140 °C (284 °F) are not critical. Please note that mineral oils are not generally recommended for bearing temperatures above 120 °C (248 °F).

Minor out of tolerances in respect of the property parameters for corrosion protection, wear protection and water separation ability can be accepted under controlled conditions. The requirement in respect of corrosion protection is of minor importance if all free water is removed and water content is always kept near 200 ppm by adequate water/oil separators, for instance.

Going through all the tests and giving explanations would take several issues of SKF Pulp & paper Practices, so I won't do it. Most of the tests are standardised ISO and/or DIN ones. Instead, I will just append a copy of the results for one oil we tested. Please note that the artificial process water used for the EMCOR test and corrosion protection is based on five different process water formulations from different paper machines in Germany. Also, that the FE8 test is optional.

While SKF does not recommend any specific paper machine oil, we can undertake tests on behalf of our customers to determine whether oil is suitable or not. In order to do all the tests, we need 10 litres of fresh new oil. Please note that if the oil is rated as suitable as a result of the tests, this doesn't mean that SKF recommends it for the dryer section. It simply means that the sample tested is suitable. The reason to stress this point is that oil formulations can change without the product being renamed. Consequently, the infrared spectrum included in the test report is very important as it allows us to compare batches of oil simply by redoing this test. As such, I recommend that two litres of new batches of oil are kept as a precaution.

In conclusion, while we have devoted two issues of SKF Pulp & Paper Practices to drying and Yankee cylinder bearings, we could write a lot more. That said, judging by the questions that I get asked by mills at least, the most important issues have been dealt with.

requested by:	Customer
sample:	1 oil XYZ

lubricant analysis

Test of oil acc. to SKF requirements for circulating lubricating oils in paper machines

Investigation: acc. to SKF specification "Requirements to be met by circulating lubricating oils for dryer sections of paper machines"

Results: see enclosure 1



Infrared-analysis: see enclosure 2

Evaluation:

XYZ	SKF roller test (roller)	120°C +	140°C +	wear protection (four ball test)	-
	SKF roller test (oil)	-	-	SKF Emcor	
	SKF oil film ageing test	+		dist. H2O	+
	copper protection	+		artificial process water	-
	FE 8 test	not ordered		water separation ability	+
	seal material compatibility	+		cleanliness	-
		+		filterability	+

Test passed: +

Test failed: -

Conclusion:

The investigated oil showed poor thermal and chemical stability at 120°C and 140°C, though no incrustation, sludge formation and roller attack occurred; the increase of the viscosity was excessive, therefore the roller test is not passed.

The corrosion protection under the presence of distilled water was excellent, whereas the corrosion protection under the presence of artificial process water was insufficient.

The wear protection was determined with the four ball test and the obtained results were out of specification. Similar results can be expected when additionally the FE8 test would have been done. This test was not ordered by the customer.

Also the cleanliness class was out of specification and therefore it is recommended to filter the oil during the filling of the paper machine.

All other test results were acceptable.

Due to the viscosity increase during the roller test and the insufficient corrosion protection, the oil can not be recommended for circulating lubrication of bearing in the dryer section of paper machines.

written by: Ch. Greubel STW4

distributed to: Customer, SKF Pulp & Paper Segment, STW4

enclosure 1

test results

oil designation: C3301/12 XYZ

material: not known

test		test method	unit	results	requirement						
chemical and thermal stability at 120°C	corrosion of rolling bearings	roller attack after 2 weeks 4 weeks 6 weeks 8 weeks	SKF roller test	rating	120°C 140°C	max. 2					
					1		1				
					1		2				
					1		2				
	oil ageing	kinematic viscosity at 40°C after ageing	DIN EN ISO 3 104	mm ² /s [% deviation]	245,1 +30,7	265,5 +68,6	max. +/- 20% from fresh oil				
					sludge formation	visual		-	none	none	traces
					incrustation	visual		-	none	none	none
	oil film stability	colour after dilution 1:50 with n-Heptan	to VDEW colour chart	dye number	3...4	5...6	max. 6				
		evaporation loss after 4 weeks	SKF method (only at 120°C)	[m-%]	7,0		max. 20 at 120°C				
	oil film ageing	rating		1		max. 2 at 120°C					
corrosion of brass 120°C	copper strip test 48 h	DIN 51 759	rating number	1		max. 2					
kinematic viscosity at	40°C 100°C	DIN 51 562-1	[mm ² /s]	187,5 18,6							
corrosion protection; dist. water artificial process water		SKF EMCOR DIN 51 802	degree of corrosion	0 / 0 2 / 2		max. 1					
wear protection under 600 N/hour		DIN 51 350-3	[mm]	2,0		max. 1					
water separation ability		DIN ISO 6614	[minutes]	15		max. 20					
seal material compatibility		SKF method after 200 h NBR at 120°C FKM at 150°C	changes hardness Shore A weight [%]	hardness: NBR: +5,9 FKM: +2,2 weight: NBR: -4,7 FKM: -0,1		hardness: NBR +/-10Shore FKM +/-10Shore weight: NBR: +/- 10% FKM: +/- 5%					
cleanliness	water content fluid contamination class	DIN 51 777-2 ISO 4406	[ppm]	<100 22/21/17		max. 200 max. 18/15/12					
filtration		SKF method 12 µm	[minutes]	10		max. 15					

evaluation:

requirements	satisfied	conditionally satisfied	not satisfied x
remarks			

written by: Ch. Greubel STW4

distributed to: Customer, SKF Pulp & Paper
Segment, STW4

enclosure 2

Infrared analysis

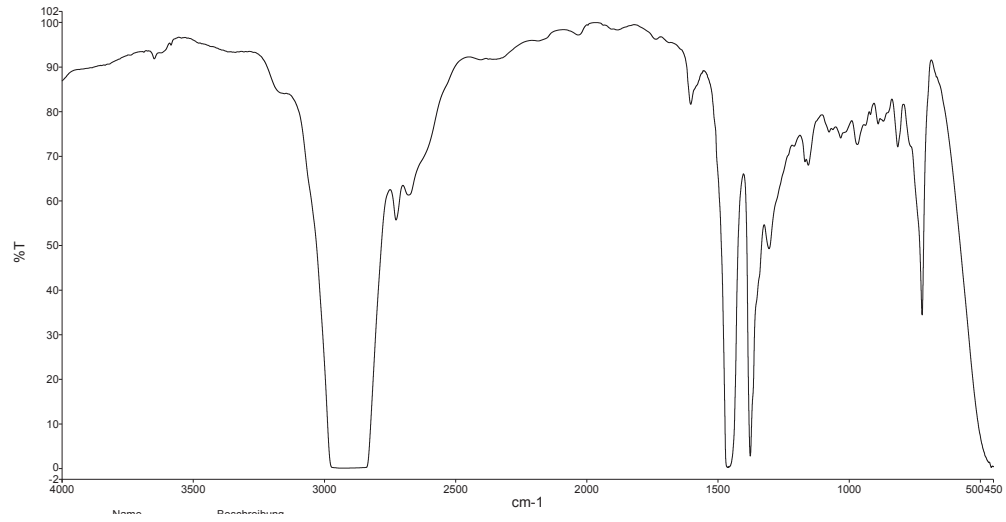

written by: Ch. Greubel STW4

distributed to: Customer, SKF Pulp & Paper
Segment, STW4

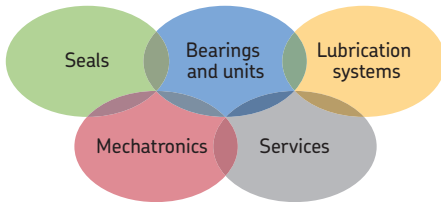

The Power of Knowledge Engineering

Drawing on five areas of competence and application-specific expertise amassed over more than 100 years, SKF brings innovative solutions to OEMs and production facilities in every major industry worldwide. These five competence areas include bearings and units, seals, lubrication systems, mechatronics (combining mechanics and electronics into intelligent systems), and a wide range of services, from 3-D computer modelling to advanced condition monitoring and reliability and asset management systems. A global presence provides SKF customers uniform quality standards and worldwide product availability.

SKF Global Pulp & Paper Segment

Contact/Responsible editor
philippe.gachet@skf.com

© SKF and CARB are registered trademarks of the SKF Group.

© SKF Group 2012

The contents of this publication are the copyright of the publisher and may not be reproduced (even extracts) unless prior written permission is granted. Every care has been taken to ensure the accuracy of the information contained in this publication but no liability can be accepted for any loss or damage whether direct, indirect or consequential arising out of the use of the information contained herein.

PUB 72/59 11147/6 EN · December 2012

Certain images used under license from Shutterstock.com.





Contamination, corrosion and inadequate lubrication

“In my business development role for SKF self-aligning bearings I work with lots of customers from many different industries all over the world. The industries they are involved in are different and their processes, equipment and applications vary, but a common theme in my conversations with them is their need to increase output and efficiency. I believe that self-aligning bearing systems can often make a significant contribution to this.”

The handling and initial mounting of bearings can have a significant influence on how they perform in service in all industries. This is also true for those bearings that suffer from contamination either prior to mounting or in service. While my customers in the mining and steel industries would be amused to hear a paper mill described as a harsh environment, the fact of the matter is that a large percentage of bearings that fail prematurely in the paper industry do so due to liquid contamination.

This issue of SKF Pulp & Paper Practices looks at the things that can be done about contamination in the pulp and paper industry. There are a number of options of course, but sealed self-aligning bearings can often be a good choice when liquid contamination is an issue. Such bearings are manufactured in the same production process as their open counterparts with additional steps to fill them with appropriate grease and to insert the seals. As they are “factory sealed”, contamination prior to or during mounting is extremely unlikely. In service they offer additional security against liquid contamination and resulting problems with corrosion or inadequate lubrication.

Kindest regards,
Ilan Bloxham
Global Business Development Manager self-aligning bearings
ilan.bloxham@skf.com
(T) +44 (0)1582 496329



Sealed Spherical Roller Bearings

This issue of SKF Pulp & Paper Practices is about why I recommend mounting sealed spherical roller bearings when it's appropriate and possible to do so. Essentially, it's about protecting bearings from contamination. Of course, there are a large number of possible sealing solutions, but to cover them all would take a book. So, think of this as just a first taste.

Before I go any further, I should say that the SKF range of sealed spherical roller bearings is growing every year. Large size bearings, such as the 231 series up to 400 mm (15.748 in) bore – which can be found in some twin press rolls, screw presses and press rolls – are now available. As such, it's time to remind everyone that sealed bearings can be a good way to increase service life.

Main bearing failure causes

While inadequate lubrication is the main cause of reduced bearing life generally, this isn't the case in paper machine applications. For all applications in all industries, it is estimated that 90% of bearings outlive the machines that they are installed on, 9.5% are replaced during planned maintenance and that 0.5% fail. Of the failed bearings, 36% fail due to inadequate lubrication and 14% due to liquid or solid contamination. The situation for bearings in paper machine applications is quite different. Very few bearings outlive the paper machine they are installed on with 40–50% failing due to liquid contamination. Corrosion marks can often be seen on these. Even if they cannot, the problem is inadequate lubrication due to too high water content in the lubricant.

The difference between inadequate lubrication and liquid contamination is not always clear. For instance, there can be enough water in the lubricant to disrupt the oil film between the bearing surfaces without creating corrosion marks (see **figure 1**).

The corrosion protection properties of lubricants have improved over the years and most damaged bearings sent to SKF for analysis come without a lubricant sample. As such, it is often only possible to diagnose inadequate lubrication from the damage that can be seen. Consequently, my opinion is that failures due to liquid contamination are underestimated especially in the paper industry.

After liquid contamination, solid particle contamination is thought to be the most common cause of bearing failures in the paper industry. That said, this conclusion is open to discussion. Let me explain using an example to show why.

A number of damaged bearings were either sent to SKF or examined during visits to the mill in question. Most of these had failed resulting in unplanned stops. A number were costly large size bearings. As they had been mounted on the paper machine, the pulp press and pulp washers, most of the failure causes were liquid contamination and/or inadequate lubrication. We signed a maintenance contract with the mill and one of the key performance indicators (KPIs) was to reduce bearing consumption.

To reach the KPI, I proposed examining all replaced bearings with the mill's maintenance staff. As there were so many bearings to inspect, we decided to do quick inspections on most and detailed Root Cause Failure Analysis (RCFA) reports on a few. We agreed that the mill would store, in good conditions, all replaced bearings together with details of the bearing, the application and the reason for replacement.

Before the contract was signed, most of the bearings that I examined would have simply been replaced and scrapped without any damage analysis. Very quickly it was established that most bearings had raceway damage due to solid contamination. Further investigation showed that a large proportion had been contaminated with solid particles either during mounting or when they were lubricated. Some had been contaminated when in store (see **figure 5**).

Fig. 1 Surface distress and spalling can be seen on the outer ring raceway of this wet section press roll bearing. The cause is inadequate lubrication. The remaining grease on the cage looks like it has been contaminated with water which leads to the conclusion that inadequate lubrication is the consequence of liquid contamination. If no grease was present, it is likely that the failure analysis would have incorrectly been simply inadequate lubrication.



We took several steps in an attempt to improve the situation:

- 1 A wooden workbench on which pumps, gearboxes and other equipment were assembled was topped with stainless steel to make it easier to clean (see **figure 2**).
- 2 The workshop doors were modified to prevent drafts blowing dust around.
- 3 Dirty and inadequate lubricating tools were replaced (see **figures 3 and 4**).
- 4 The maintenance team was given special training on workshop cleanliness.

Fig. 2 Wooden workbenches are difficult to clean properly.



Fig. 3 and 4 A cut down plastic bottle used to transfer grease from its original drum to a bucket that is used to lubricate open bearings.

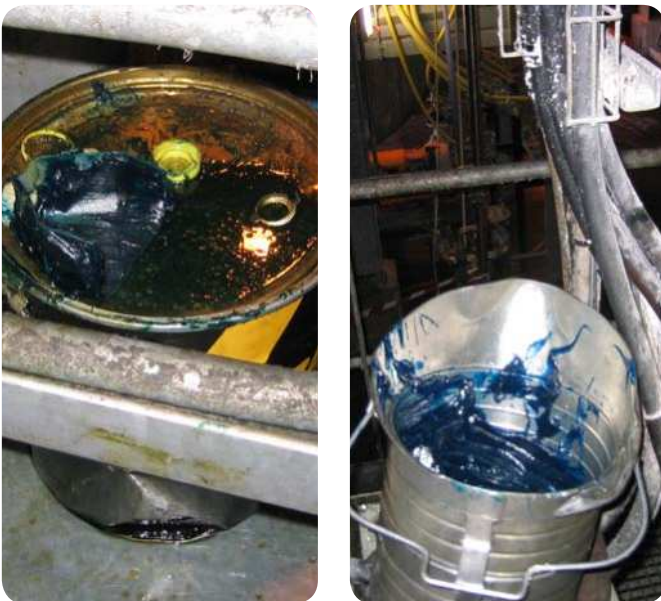

Bearing consumption fell as a result of these actions, but there were still some bearings replaced due to solid or liquid contamination during operation. This was due to lack of sealing efficiency.

So, what more can we do to reduce bearing damage due to contamination? There are a number of options, each with pros and cons, in my experience.

Storage conditions

The fourth edition of SKF Pulp & Paper Practices included some information on this. Namely, that the storage area must be clean, dry and free from drafts. I should also add that bearings should be stored flat and in a vibration-free environment.

But what does dry mean? It means that the recommended relative humidity should be kept below 60% with a peak of 65% accepted. This guideline is based on knowing that unprotected bearing steel will start to corrode at a relative humidity of 50%, that corrosion accelerates when relative humidity increases and that it will happen quickly when above 75%.

Temperature fluctuation is also important. When moving packed bearings between different locations, the temperature is likely to vary. The air confined in the bearing packaging differs from that outside in that its water content changes much more slowly, while external temperature changes have immediate effect. If the temperature of the package drops the relative humidity inside will increase. For example, if a packed bearing has been stored for a long time at 30 °C (86 °F) and 50% relative humidity and it is transferred to a place where the temperature is only 20 °C (68 °F), the relative humidity will reach 100% and water can condense inside the packaging. Conversely, if a packed bearing is moved from a cool to warm environment, condensation on the relatively cool steel surface may occur. This is why SKF has a conservative recommendation i.e. a maximum storage room temperature fluctuation of 3 °C (5,4 °F) per 48 hours.

Fig. 5 Bearing stored without protection from dust.



Following these recommendations on temperature fluctuation and relative humidity will help to avoid corrosion marks.

Avoiding solid contamination is simple in theory. Just don't open the bearing packaging until it's time to mount the bearing! I say simple in theory because, in reality, paper mill staff will often open the packaging to check the bearing is the same as the one that needs replacing or to check that the designation indicated on the box is correct. In practice, many bearings are opened and then put back in storage for use later on. Bearings in good condition that are dismounted and put back in the store are another issue. They need to be cleaned and protected against corrosion and solid contamination. I will write more about this in a future issue of SKF Pulp & Paper Practices.

What can be said with certainty is that bearings with integrated seals protect themselves against dust. As far as their internal surfaces are concerned, at least.

Mounting conditions

Can I write anything more than bearings should be mounted in a clean environment that is as free as possible of drafts? Yes, but real life shows that you sometimes just have to do your best to avoid the bearings being contaminated in environments and time frames that you would not have picked given the choice. People do not always help as they have little idea that a 0.1 mm (0.004 in) brass particle can reduce the life of a 500 kg (1 100 lb) bearing by a factor of 10.

Sometimes mounting bearings in less than ideal conditions is bad for the morale of the engineer who has calculated the bearing rating life accounting for the contamination factor. That said, you don't need to be in a sandstorm to be in a harsh environment for bearings. You could be mounting a bearing in the wet section while someone is working above you or changing a bearing on the floor of a dirty workshop when the doors are open to catch the breeze.

Fig. 6 Fibre leaking out of the gland seal on a pulp washer. Note the additional protection in front of the housing to protect the housing seal.



The worst case I ever had to face was in my mining days mounting a bearing on a vibrating screen in a quarry. Two men from the quarry were holding a plastic sheet trying to protect the bearing and me. I remember wishing at the time that the bearing had integrated seals.

During operation

Bearings in operation must be protected against contamination that could bypass the housing seal assembly. This contamination can be either:

- 1 Solid and liquid such as fibre in the pulping process (see **figure 6**)
- 2 Liquid like process water in the forming section (see **figure 7**)
- 3 Solid only

The first step is to keep the contamination out of the housing. I'm not going to write about all the different seal arrangements that SKF can offer, but will just cover some considerations based on my personal experience.

Seal assemblies need to be efficient and reliable. This all depends on the possible contamination and the life required from the sealing arrangement. By life, I mean how long it keeps contamination from reaching the bearing. A small amount of contamination can pass the seal and still be considered acceptable if the bearing service life is not dramatically reduced. For example, some process water can enter a suction roll bearing housing if it is then quickly removed by the lubricating oil and efficient water separators. Similarly, if fresh grease inserted during lubrication purges old and contaminated grease from the bearing and seal.

Fig. 7 The high humidity environment of a wire stretch roll in a paper machine forming section. Grease in the labyrinth seal stops process water entering the bearing housing.



Each seal design has advantages and disadvantages. It isn't easy to have high performance seals without creating friction and/or a complicated sealing arrangement. Factors like friction and cost tend to limit seal efficiency. However, I have some of my own rules based on my experience:

- 1 Try to avoid friction seals whenever possible. Note that I use V-Rings as deflectors or as a kind of one direction valves (see **figure 8**).
- 2 It is better to add several small barriers for cascading protection rather than a single high performance barrier (see **figure 9**). The idea behind this point is that a barrier can always fail, especially if there is friction and thus wear.
- 3 Lubricant, such as grease, can be considered as a barrier.
- 4 Remember that rotary shaft lip seals need to have their lip lubricated and that they have a pumping effect.
- 5 Excess grease in a bearing must always be able to escape to avoid overheating. There are exceptions for very slow rotating bearings.
- 6 Sealing arrangements should use standard seals, simple do it yourself components such as covers or rotating discs or quickly made machined seals like those available from SKF Economos (see **figure 10**).
- 7 With rotary shaft lip seals, the lip seat must be easy to repair (e.g. with a thin wear sleeve such as SKF SPEEDI-SLEEVE) or easily changeable. If the lip seat is a wear sleeve, it has to have a sufficiently tight fit that it doesn't rotate with the lip and to prevent liquid passing under the wear sleeve's bore. An "O-Ring" or seal paste can prevent liquid from passing underneath the wear sleeve. Lip friction on the wear sleeve can increase the temperature of the sleeve and make it expand radially.

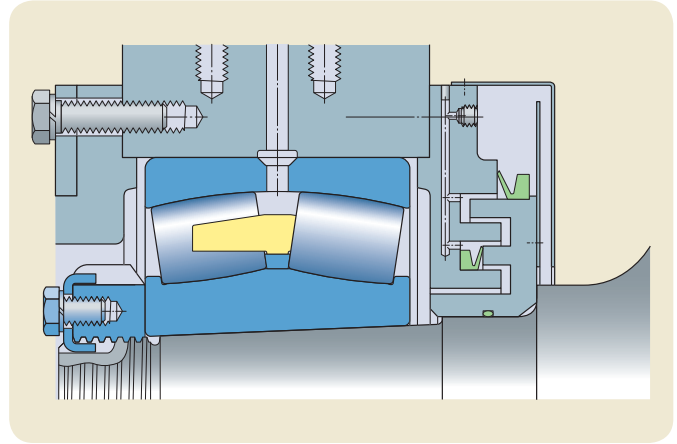

Fig. 8 The addition of a cover, a rotating disc and an additional V-Ring on a suction roll.

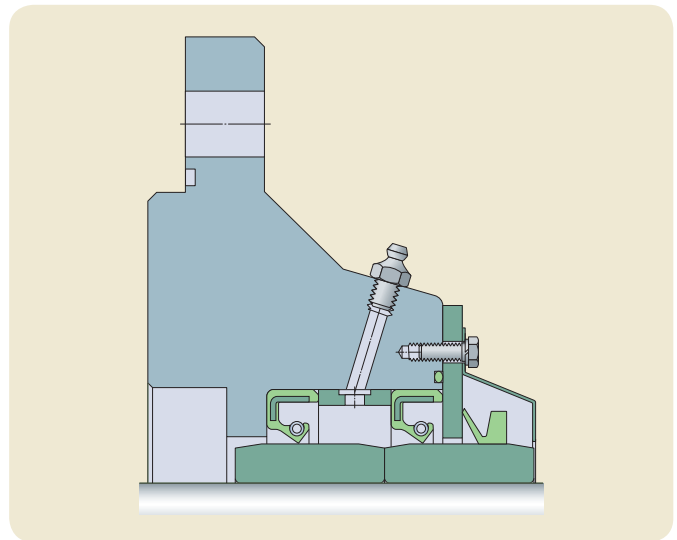

Fig. 9 Example of a seal arrangement for a harsh environment.

Fig. 10 SKF SEAL JET is able to machine polymeric seals to tailor made shapes and dimensions to fit a customer's application. It is often used as an alternative in cases where adding a standard seal to increase sealing efficiency requires costly modifications.



So, when it is possible to avoid friction seals, do so. **Figure 11** shows an example with four barriers: a cover to protect the labyrinth seal, a rotating labyrinth seal that acts like a disc deflecting liquid contamination, a grease-filled labyrinth seal and the grease between the bearing and the labyrinth seal.

If this isn't good enough, it might be possible to add V-Rings.

Figure 8 shows an old suction roll whose original seal arrangement was just a labyrinth seal filled with grease. After a few bearing failures due to liquid contamination, the following modifications were made:

- 1 The addition of a cover made by the paper mill and a disc made of stainless steel sheet.
- 2 The addition of V-Rings that allowed excess grease in the bearing to escape, but which prevented the contamination and/or the contaminated grease in the labyrinth from entering the bearing housing.

Note that there is an O-Ring between the shaft and rotating labyrinth since water can pass between these two due to form errors.

In some cases there is a need for friction seals. In pulp press applications, for example. My favorite seal arrangement for harsh environments looks like the one in **figure 9**. Two rotary shaft lip seals are placed in tandem, lips facing outwards, to let excess grease escape. As the grease escapes it lubricates the seal lip and forces away contamination. New grease is introduced between the two rotary shaft lip seals.

Such arrangements are often used for low speed applications. With these, the bearings don't necessarily have to be lubricated as often as the seals. This can help reduce grease consumption. It also allows different greases to be used for the bearings and seal arrangements. For example, high viscosity grease with solid additives such as SKF LGEV 2 could be used for the bearings while SKF LGHB 2, which has good mechanical stability when mixed with water and very good anti-corrosion properties, can be used for the seal arrangement.

In this arrangement, the V-Ring and cover act as deflectors to minimise contamination reaching the right hand rotary shaft lip seal which could increase lip wear. It is a good example of the barrier cascade principle. The cover protects the V-ring, which protects the right hand rotary shaft lip seals, which protects the grease, which protects the left hand rotary shaft lip seal. The wear sleeves are mounted with a slight tight fit and seal paste.

But what happens if contamination passes through the housing seal assembly anyway?

Well, if it is an open bearing, you will have to rely on the lubricant surrounding the bearing to keep the contamination away from it. Circulating oil with good filters and liquid separators is one solution, but you can do more than just rely on the lubricant.

In cases of solid contamination, SKF can offer a bearing completely filled with a polymer matrix saturated with oil called SKF Solid Oil (see **figure 12**). As all the free space in the bearing is filled with the polymer, solid contamination cannot enter. Because the polymer completely fills the free space in the bearing, speed is limited and start up friction is higher than with grease or oil. For E type spherical roller bearings the ndm limit is 42500 and for CC type spherical roller bearings it is 85000.

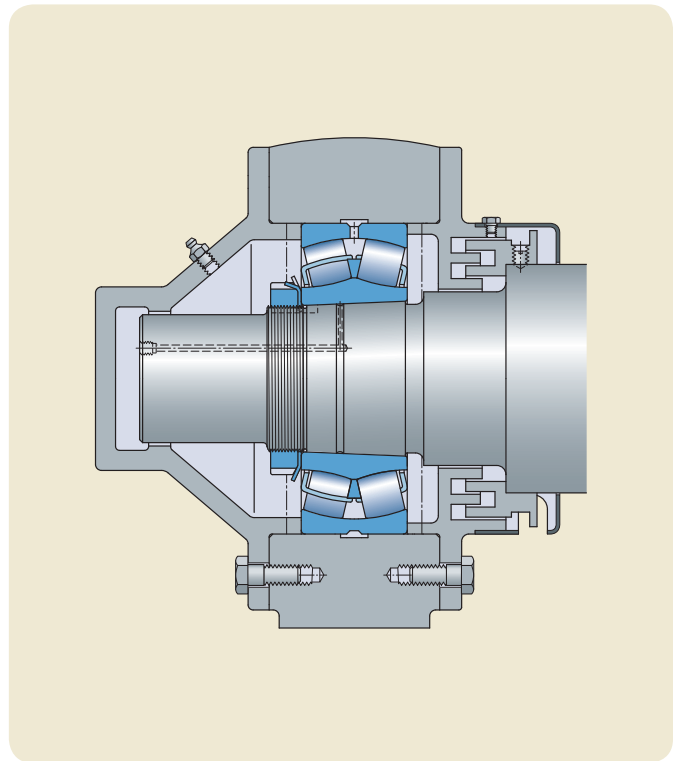

Fig. 11 Wire roll bearing housing without friction seal.

Fig. 12 SKF Solid Oil bearing.



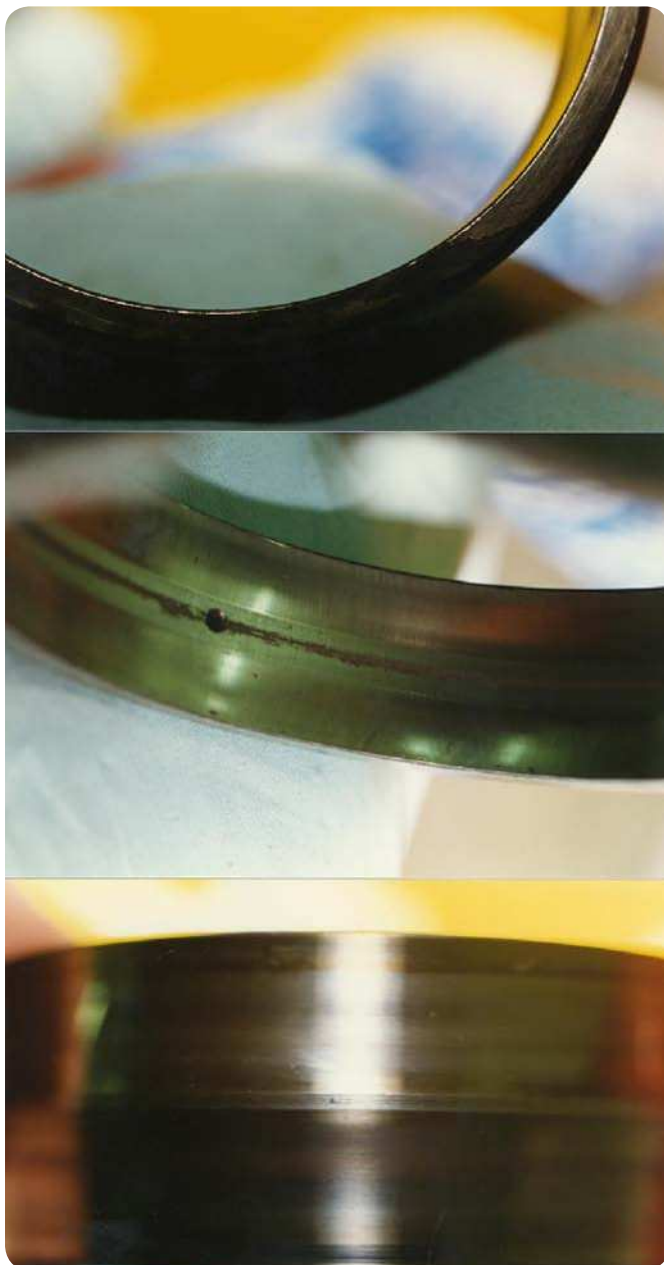

Fig. 13 Solid Oil bearing after 8 months in operation on a felt roll with water in the housing. The water level in the housing can be seen from the corrosion on the outer ring side face in the upper photograph.

Note that $ndm = \text{speed} \times \text{mean bearing diameter}$ (see **issue 7** of SKF Pulp & Paper Practices). The temperature is also limited to $85\text{ }^{\circ}\text{C}$ ($185\text{ }^{\circ}\text{F}$) in continuous operating conditions. Therefore, the Solid Oil solution is perfect in slow rotating dusty applications such as material handling or in the converting plant.

Even though it isn't recommended for humid environments, we have tried Solid Oil bearings in felt roll applications. Three spherical roller bearings were mounted on a felt roll in France in December 1992. The customer understood that there was no need to fill the housing with grease. Maybe I wasn't precise enough on the fact that grease in the housing would protect the bearing against water ingress and possible corrosion of the outer surfaces of the rings and the housing bore. The bearings were dismantled in August 1993 after they had run in a process water bath. You can see the water



Fig. 14 SKF HNCR spherical roller bearing for the wet section of a paper machine. Photograph taken for SKF Pulp & Paper Practices before being packed and sent to the customer earlier this year.

level based on the corrosion on the outer ring side face in **figure 13**. It was a success, but I promote Solid Oil with caution after a customer complained that the roll wouldn't rotate at start up and that the felt was sliding on the roll. The felt wrap angle over the roller was too low leading to low contact load between felt and roll. Felt rolls can be put in several positions so there is a risk that a felt roll equipped with Solid Oil is put in a position where the contact load between felt and roll is too low. I recommend that Solid Oil spherical roller bearings should have a minimum load equal to $0.02 C_0$ ($C_0 = \text{basic static load rating}$).

In addition to the friction and the temperature and speed restrictions, Solid Oil has another disadvantage. It cannot be relubricated. It is a bearing lubricated for life and it isn't a standard bearing. So, are there other options? Yes, there are.

With liquid contamination that causes corrosion, one idea is to mount a stainless steel bearing. SKF has a range of nine spherical roller bearings covering the most popular felt and wire roll bearing sizes. These bearings are not made from regular 440C stainless steel, but rather from a highly corrosion-resistant, due to nitrogen addition, and clean stainless steel. The stainless steel is called HNCR, which is indicated in the bearing designation, and the bearing is produced by MRC which is part of the SKF Group (see **figure 14**).

It was decided to create a range of bearings for felt and wire rolls after a success in a paper mill in the USA. The previous bearings had an average service life of 36 months due to process water ingress in the bearing. They were replaced by HNCR spherical roller bearings and the external seal design was slightly modified. These HNCR bearings now achieve a seven year service life.



Fig. 15 SKF sealed spherical roller bearing.

As standstill corrosion - which happens when a paper machine is stopped for maintenance - is one of the primary causes of bearing failure, these HNCR bearings can be seen as a good solution. That said, we must keep in mind that if liquid contamination enters the bearing, there is a risk of inadequate lubrication and low service life. This bearing is also less sensitive when its packaging is subjected to condensation. Unfortunately, the cost and small range limit the general use of these high quality stainless steel bearings in paper mills.

Another alternative, which I believe to be the best, is to use sealed bearings (see **figure 15**). Everybody knows about the sealed deep groove ball bearings, but most are not aware that SKF has the largest range of sealed spherical roller bearings with bearing bores from 25 (0.984 in) up to 400 mm (15,748 in). Like the Solid Oil bearing, the sealed spherical roller bearing is protected against contamination during storage, when left unpacked and during mounting. However, it is a standard bearing that can run faster with less friction and it can be relubricated. Technical information about these bearings can be found in the SKF General Catalogue or on the SKF homepage (www.skf.com).

The fact that it isn't possible to measure the internal radial clearance with a feeler gauge for mounting purposes shouldn't be a concern. SKF generally recommends the SKF Drive-up Method (see SKF Pulp & Paper Practices **issue 3**) which is far superior to the feeler gauge method.

The first time I saw a sealed spherical roller bearing, it was an SKF one, code name Celia. It was when I started to work for SKF some 23 years ago. That sealed spherical roller bearing had ISO dimensions and as there was little space for the seal since it could, in some cases, touch the cage or the rollers, the seal needed to be protrud-

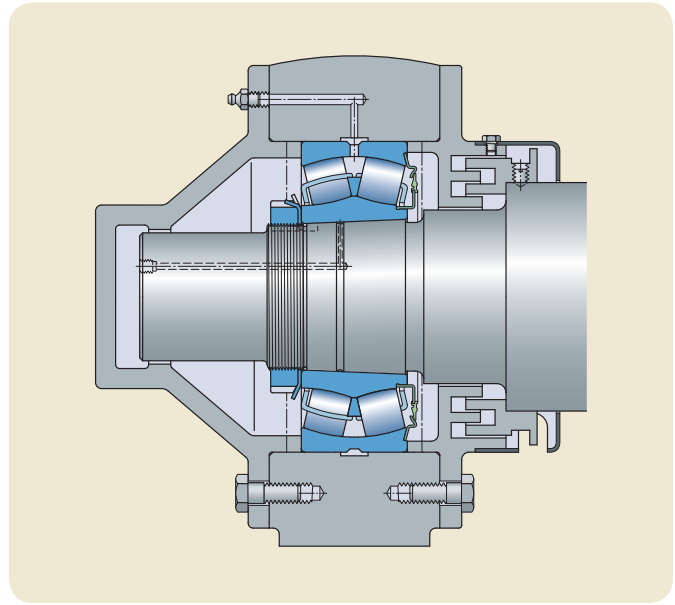

Fig. 16 Celia type sealed spherical roller bearing on a felt roll. In this particular case, there is a single seal. The bearing seal is designed to allow excess grease to be purged. Purged grease pushes out grease and contamination in the labyrinth seals and acts as a barrier to further contamination. Even if contamination enters the bearing housing, it will have difficulties to enter the bearing.

ing. Bearings could be delivered with a seal on each side or just one seal on one side. One of the first applications for it was for felt rolls (see **figure 16**).

Paper industry customers were satisfied since these sealed spherical roller bearings had a longer service life. Unfortunately, the main customers for such bearings were steel mills and they complained about the protruding seals as they could be damaged during handling. The second generation of SKF sealed spherical roller bearings didn't have protruding seals. Some bearings, mainly the CC type, could integrate the seals without increasing the width of the bearings. These are mainly medium and large size bearings that can be found in many applications and which are dimensionally interchangeable with open bearings. They can be found in standard housings in the wood yard, on pulp presses, in some paper machine applications (e.g. suction roll internal bearings – see **figures 17** and **18**), on winders and in the converting plant.

The smaller bearings with increased load carrying capacity (SKF E type) don't have much space for the seals and must have wider rings. This means that if a customer replaces an open bearing with one, some modifications might be required. For example, **figure 19** shows a larger sealed bearing mounted in place of the bearings shown in **figures 11** and **16**. In this case, housing covers and the shaft had to be modified.

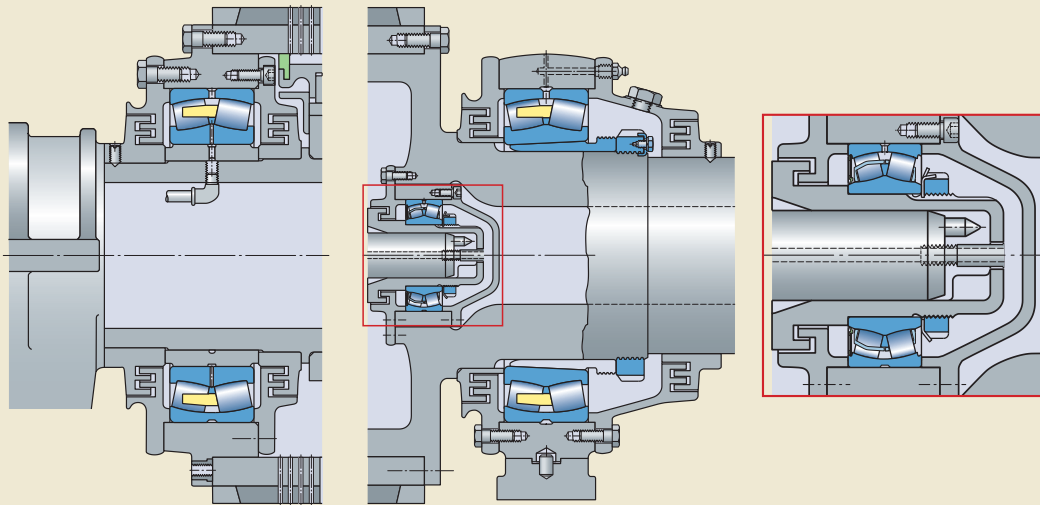

Fig. 17 Suction roll internal spherical roller bearing with a seal on one side (the other having been removed during mounting). Grease is able to travel through the bearing.

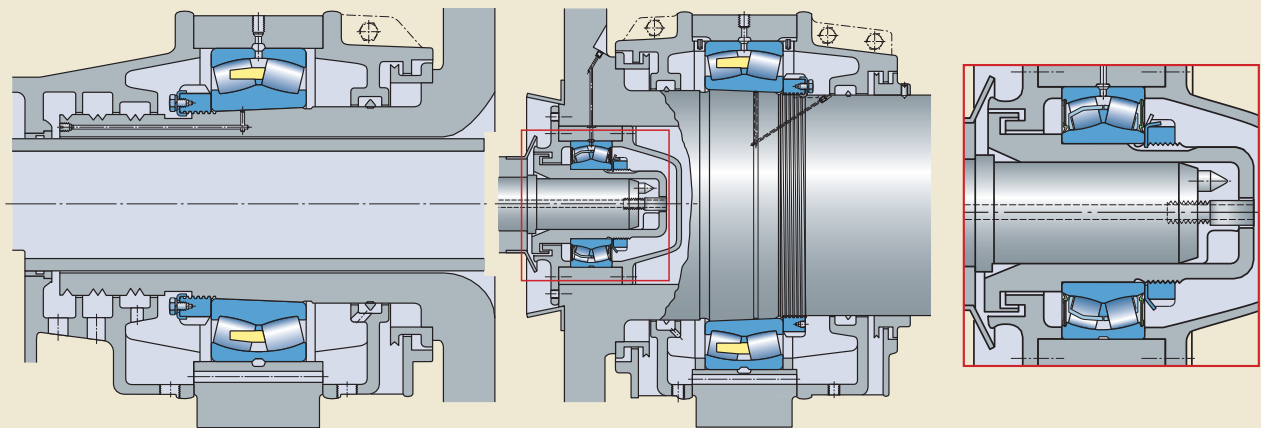

Fig. 18 Suction roll internal spherical roller bearing with a seal on each side. This bearing is lubricated via the lubricating holes and groove on its outer ring

In most applications, the seals of the sealed spherical roller bearings are used to offer a last barrier against contamination. The SKF literature often talks about the “Three Barrier Concept”. The first barrier is the housing seal arrangement. The second barrier is the grease between the bearing and the housing seal arrangement, and the last barrier is the integrated bearing seals. This, of course, follows my rule number two about adding small barriers with cascading protection.

Like sealed deep groove ball bearings mounted in automotive gearboxes, sealed spherical roller bearings can be mounted in industrial gearboxes lubricated by oil. Gearboxes can have heavy solid contamination in the oil. The integrated seals will eventually let some oil pass, but the solid contamination is kept out of the bearing.

In closing, I hope that I have given you some ideas on how to reduce your bearing consumption due to contamination and that the sealed spherical roller bearing, which is a widely available standard product, can be an economical way to increase your bearing service life. Unfortunately, SKF Pulp & Paper Practice has a limited number of pages so I cannot go into as much depth as I would have liked to. So, for more technical information on seals, Solid Oil and sealed spherical roller bearings see the SKF General Catalogue or the SKF Industrial shaft seal Catalogue. For more information on the HNCR bearings, please contact SKF and ask for the M890-600 publication called "Corrosion resistant spherical roller bearings".

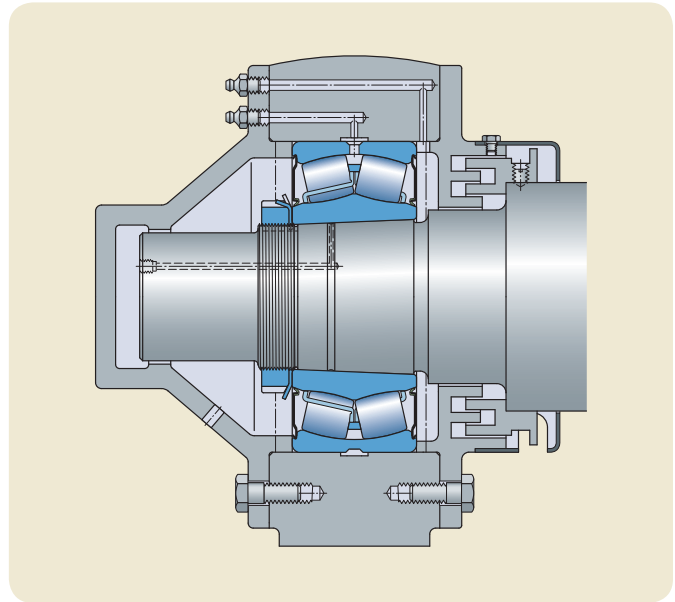
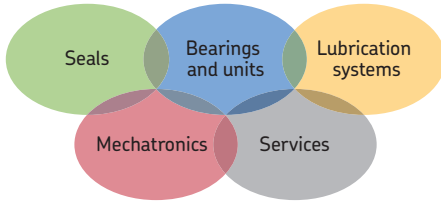

Fig. 19 Sealed spherical roller bearing in a felt roll application. It is wider than a standard ISO bearing. The seals on both sides are retained to avoid contamination during mounting. Excess grease in the bearing can be purged from either side. In such applications, short relubrication intervals are used to push contamination out of the housing rather than to relubricate the bearing. With such an arrangement, it is possible to pick the most suitable grease for the bearing and a different grease to act as a barrier to process water. Note the addition of an O-Ring under the rotating part of the labyrinth.



Regards,
Philippe Gachet
Senior technical consultant
philippe.gachet@skf.com



The Power of Knowledge Engineering

Drawing on five areas of competence and application-specific expertise amassed over more than 100 years, SKF brings innovative solutions to OEMs and production facilities in every major industry worldwide. These five competence areas include bearings and units, seals, lubrication systems, mechatronics (combining mechanics and electronics into intelligent systems), and a wide range of services, from 3-D computer modelling to advanced condition monitoring and reliability and asset management systems. A global presence provides SKF customers uniform quality standards and worldwide product availability.

SKF Global Pulp & Paper Segment

Contact/Responsible editor
philippe.gachet@skf.com

© SKF is a registered trademarks of the SKF Group.

© SKF Group 2013

The contents of this publication are the copyright of the publisher and may not be reproduced (even extracts) unless prior written permission is granted. Every care has been taken to ensure the accuracy of the information contained in this publication but no liability can be accepted for any loss or damage whether direct, indirect or consequential arising out of the use of the information contained herein.

PUB 72/S9 11147/7 EN - April 2013





Simple components?

When you consider a complete machine or industrial process, a bearing can seem like a simple component. SKF knows, of course, they are not which is why we employ so many engineers worldwide.

Simple components – and not just bearings – are often given too little attention by the people who use them. By this, I mean too little attention to their selection, installation and maintenance. To be fair, many of our customers know that bearings are the very sensitive hearts of their rotating equipment. Such customers care about all aspects of their use and are happy to ask SKF for advice and support. However, it's the customers who do not think and act like this that I am more worried about.

As I said at the start, the SKF Group employs lots of engineers. Personally, I tend to recruit design engineers because the applications for our simple components require a very wide range of mechanical design skills and because my engineers are involved in much more than simple life calculations.

My engineers are there to work with your technical staff and the reliability of your machinery, but to do this we need to know the conditions under which your bearings operate. This issue of SKF Pulp & Paper Practices will, I hope, help you better understand what you can do to help us support you.

Regards,
Domenico Restaino*
Manager, Application Engineering, SKF France
Domenico.restaino@skf.com

* shown on the right in the photograph above

Calculated Rating life vs Service life

Misunderstandings between bearing manufacturers and customers on technical matters are quite common. The customer, understandably, wants a reliable bearing so that he can avoid unplanned stops. If a bearing is going to fail, he wants to know when it will happen. In other words, he wants to know the bearing service life. Bearing manufacturers, unfortunately, are not able to state what the service life will be. They can only calculate the bearing rating life which is quite different. To further complicate matters, the calculated bearing rating life does not consider all the parameters that can influence service life and there are several rating life calculation methods which can give very different results.

Some customers see a bearing as just a piece of metal with two rings and some rolling elements. When it fails, it must be the quality or the load capacity that is the problem. Such customers don't appreciate that a bearing is not a simple component.

I cannot count the number of customers that have asked me for service life and lubrication advice without giving me enough information to check the bearing choice and whether the environment, bearing assembly and machine design will have a negative effect on life (see the example in **figure 1**). I have also lost count of the number of times that I have received either a failed bearing or a photograph of one, sometimes too badly damaged to analyse (see **figure 2**),

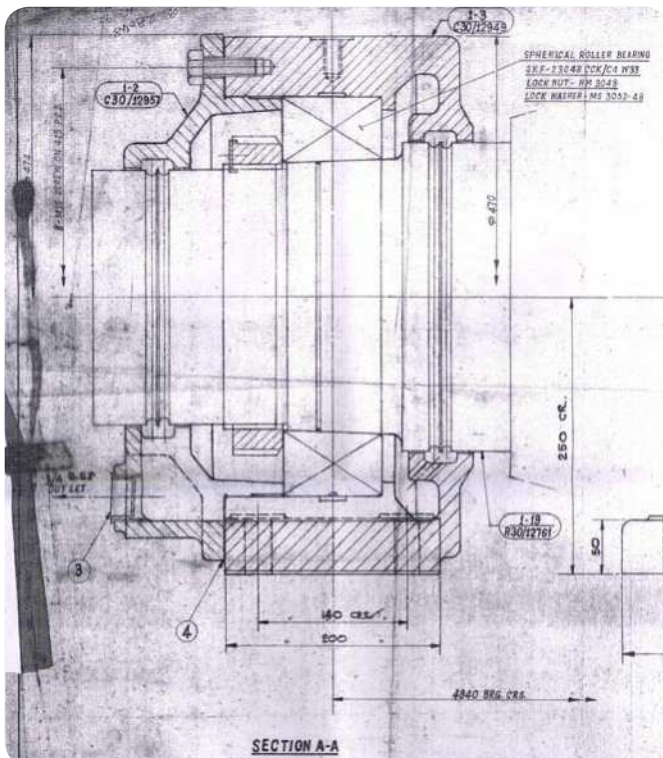

without the necessary information on operating conditions and history to deduce the most probable cause of failure.

This issue of SKF Pulp and Paper Practices will examine why it isn't possible, either today or in the near future, to state either the remaining life or the service life of a specific bearing. It will also list the information necessary for a proper bearing study and a Root Cause Failure Analysis (RCFA).



Fig. 2 A bearing that is too badly damaged to diagnose the probable failure cause. The part in the middle is what remains of the shaft that supported the bearing.

Fig. 1 A drying cylinder bearing assembly.

The bearings had a short service life despite the fact that the given load, oil flow and oil viscosity seemed to be correct. I didn't immediately realise that due to the housing design, only a small proportion of the oil flow would pass through the bearing. A colleague pointed out that the oil groove in the housing bearing seat was crossed by a large groove under the bearing designed to drain the oil. Most of the oil, that should have cooled and lubricated the bearing, was draining straight out of the housing.

1. Why it isn't possible to calculate a service life

After reading this section of the newsletter, some of you will think that I have not given this matter the space it deserves. While it is true that I omit many things, I know that if I don't it will become boring for many readers. Especially those who are not mechanical engineers or who, like me, close books as soon as they see that every second page is full of mathematical formulas.

What we call a service life is the actual number of revolutions or the time that a bearing operates in a machine. If a Yankee bearing is dismantled and scrapped as part of preventive maintenance after ten years, then the service life is ten years even if the bearing was still in good condition. If a plain press roll bearing, damaged during transport, is mounted on the machine and then removed after three hours due to excessive vibration, then the service life is three hours. If a drying cylinder bearing is dismantled following vibration caused by spalling on the raceway after 40 years, the service life is 40 years.

If we were to take a number of bearings of the same designation, manufactured at the same time, and run them with the same load and lubricant we would get the same results that they did in the lamp bulb endurance test. That is to say, they would not all have the same life.

In our test, end of life is when a small spall is detected (see figure 3).

Such spalls are created by alternating stresses in the structure of the steel due to the passage of the rolling elements. Under normal conditions, with no contamination and an adequate lubricant film thickness, the maximum stress is just below the surface. Due to the alternating stresses, the steel structure changes and micro cracks are created near the weak points. **Figure 4**, which was also shown in issue five of SKF Pulp & Paper Practices, shows the structural change between 30 and 400 microns under the raceway surface. Note the micro crack at 130 microns depth.

Fig. 3 A small spall (flaking) indicating the end of the bearing life

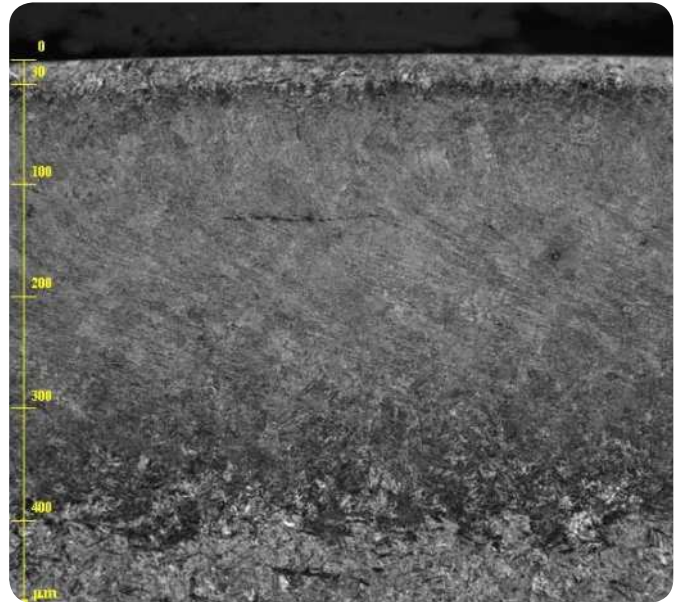
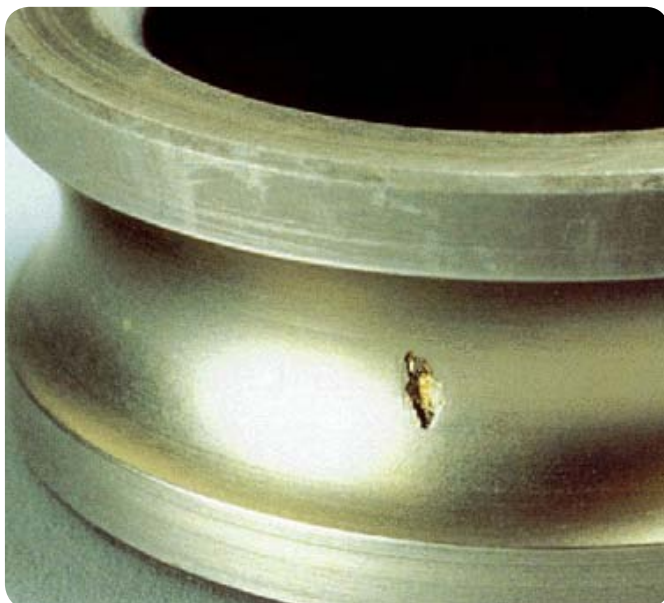

Fig. 4 Structural change and a micro crack under the raceway surface due to alternating stresses created by over rolling.

Figure 5 shows an example of an endurance test with ten bearings. Note that the first bearing to experience flaking lived for eight million revolutions (i.e. 133 hours if the speed was 1 000 rpm), the ninth bearing managed 157.2 million revolutions (2 626 hours at 1 000 rpm) and the tenth bearing had not reached the end of its life by the time that the test was suspended.

From this we can first conclude that:

- 1 Bearings operating in the same conditions will not achieve the same life.
- 2 It isn't possible to predict the life of one specific bearing before the test.

Fig. 5 Example of an endurance test.

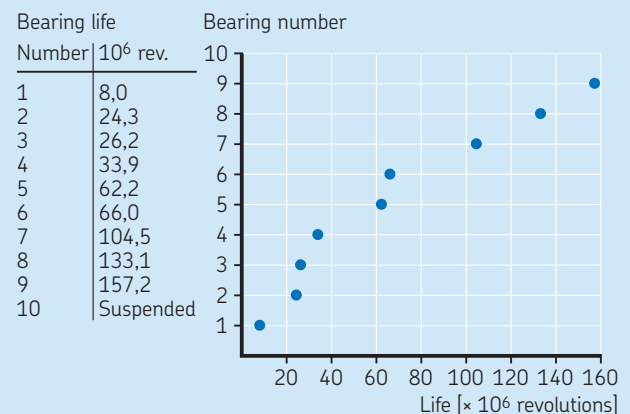

All endurance tests show that if bearing lives are plotted on a graph with revolutions (or hours) on one axis and achieved life on the other, a curve can be drawn (see **figure 6**). This curve, showing survival probability, can be made into a model using mathematical formulas.

This means that for a population of the same bearings running under exactly the same conditions, it is possible to predict the probability of survival. This will help an engineer choose the right bearing for an application.

70 years ago it was decided that a 0.9 probability of survival should be used. In other words that when calculating life, 90% of bearings should attain or exceed the desired life. So, when a paper machine manufacturer asks me to select a bearing for a plain press roll with a life equal or higher than 100 000 hours, it doesn't mean that I will propose a bearing that will exceed this. It means that I will propose a bearing, based on the theoretical operating conditions supplied by the customer, that should – in theory – run for 100 000 hours or more in 90% of cases. The obvious corollary is that in 10% of cases bearings will not achieve the requested life.

Imagine a board machine with 100 drying cylinder front side bearings operating in exactly the same conditions. In reality, I know that the operating conditions are not exactly the same as the speed varies between dryer groups and steam temperature changes etc., but for the purposes of this example, let's imagine that they are. If the calculated life for 90% reliability is 200 000 hours then, in theory:

- 99% of the bearings will attain or exceed 50 000 hours
- 95% of them will attain or exceed 128 000 hours
- 50% will attain or exceed 1.000.000 hours (five times 200 000 hours)

That calculated life, in hours, is the basic rating life L_{10h} (L for life, 10 for the 10% probability of failure with 90% reliability). This considers bearing load and speed only. There is the modified rating life, L_{10mh} , which considers solid contamination, the oil viscosity ratio and the fatigue load limit as well. Note that the fatigue load limit is the load under which, assuming appropriate cleanliness levels and lubrication regimes, bearing life is unlimited.

Unfortunately, L_{10h} and L_{10mh} are "General Catalogue" methods that assume simple load distribution. There are other rating life methods that can take shaft, bearing and housing deformation, internal clearance and real load distribution in the bearing into account. However, for exactly the same operating conditions, the results of the calculated lives can vary a lot. I will give an example later on in the 'Information needed for a bearing study' section.

So, when a customer asks me to calculate the life of a bearing, he's thinking service life. I, however, can only calculate and share the rating life with him. This is when the misunderstandings begin. Especially when I am not able to guarantee that a bearing, however well mounted and maintained, will attain or exceed the calculated rating life.

The probability of survival curve can be shown in another way that is much more interesting for customers i.e. as the number of bearings that reach life end per interval of time (see **figure 7** for an example of what such a curve looks like). It shows that the rating life estimates the time before most bearings will have to be replaced.

Bear in mind that calculated rating life is the way to select a bearing of a certain size for an application rather than to predict the service life on an individual bearing. Also that rating life is calculated based on operating conditions that may not actually be the real ones. Service life, in reality, depends on many factors that are beyond the control of the bearing manufacturer. The mounting of the bearings in a dusty environment with a large hammer, for example.

A typical error is to choose the bearing with the longest rating life hoping to get the best reliability. A customer that I know did just this. He wanted to increase the reliability of a strategic fan, so he modified the fan so that he could mount a spherical roller bearing with a very high load capacity. A consultant calculated the L_{10h} life as greater than several hundred million hours. The resulting service life was actually less than a week. In fact, the bearing was running with too low a load for its capacity and its rollers were sliding rather than rolling in the loaded zone. For the sake of a quick repair without further modifications, I decided to mount the same bearing but with two-thirds of the rollers removed. The fan then worked for eight years without a bearing change.

Fig. 6 Survival probability curve.

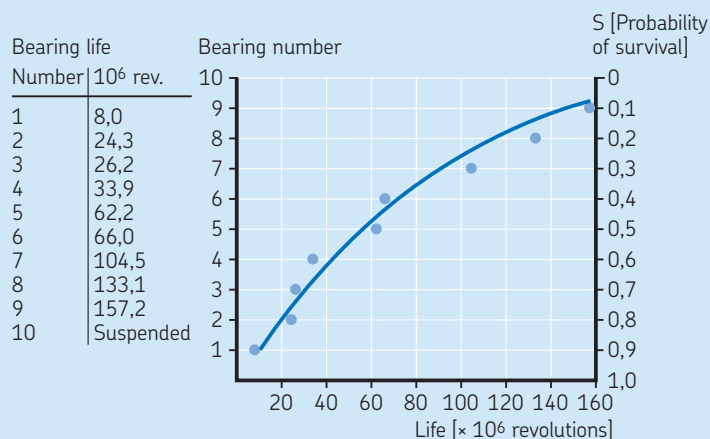

2. The information needed for a bearing study

A bearing study is the work needed to choose the type and size of bearing based on the requested rating life, the fits and the lubrication. It can also include recommendations for mounting and dismantling.

Such studies can be simple ones, based on the SKF General Catalogue, completed in less than ten minutes by experienced application engineers. They can also be much more complicated involving advanced computer programs and, sometimes, tests. Either way, the information needed to complete a study is the same.

In the following sections, I will list and comment on the information needed. In some applications, not all of it is needed, but I think it is good practice to supply it anyway.

2.1 The quantity of bearings

Information on the number of bearings needed or the bearing consumption per year is important for cases where high volume standard bearings might not be suitable for the application. This will have a direct impact on the cost involved.

2.2 Drawings

A technical drawing with the dimensions and tolerances of the bearing assembly or the position of the bearings is highly desirable. If this is not possible, a simple handmade sketch can help. Don't forget to include the drive since this can have an influence. With a technical drawing or sketch, the application engineer might see something that is not considered important by the customer. Remember **figure 1!**

I often receive cropped bearing assembly drawings. Sometimes, this means that important things that influence bearing service life are not visible for the application engineer, which may result in failures. Given this, it's best to send complete drawings.

Drawings help us understand how heat, caused by friction in the bearing or from other sources, dissipates. They also allow us to estimate bearing operating temperatures.

Materials should be indicated on the drawing as thermal expansion differences can be important. Finally, I recommend that the drawing has orthonormal vectors.

Fig. 7 The number of bearings reaching their life end versus time.

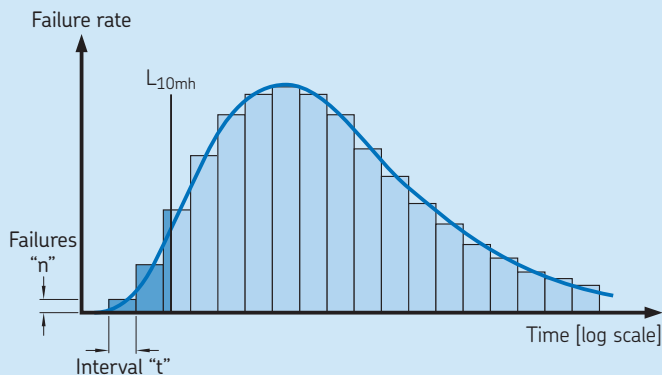

2.3 Load intensity, position and direction

Loads, including moments, should be indicated on drawings. Supplying only bearing axial and radial load may result in low bearing service life. By way of example, let's look at an ISO rating life calculation (see **figure 8**). It is simple to calculate the radial load on this cylindrical roller bearing and to supply only the calculated radial load:

$$F_r = (A+B).F/A$$

F is the load acting on the shaft i.e. the red arrow

If only F_r is known and no drawing with the real load position shown has been supplied, an application engineer will not see that the bearing has to withstand misalignment. The resulting calculated rating life – L_{10h} or L_{10mh} – could be very high. In contrast, with a drawing and knowing the load and shaft geometry, the engineer will understand that the shaft will bend under load resulting in high misalignment on the bearing. He can then use advanced software to discover that the rating life, based on the real load distribution in the bearing, is actually very low. In addition, he will understand that there is a high risk of fretting corrosion between the shaft and the bearing bore.

The information supplied should be sufficient so that load direction variations can be well understood.

A common error is to only give the maximum load thinking that if a bearing can withstand this, it can also tolerate lower loads. This is not necessarily the case as under certain conditions the rolling elements might slide rather than roll. As such, the contact load needs to be high enough to force them to roll. Therefore, the maximum and minimum loads should always be given.

Giving only maximum load might also lead to the use of oversized bearings or a situation where no bearing can be found that will fit the requested dimensions. Take reel spool bearings, for instance. With maximum load and speed, the majority of reel spool bearings used would have a short life of a few thousand hours or less. Most automotive gearbox bearings would also have bearings with calculated lives of just a few dozen hours. To avoid this, it is best to supply a load histogram showing estimated loading variation and duration.

Fig. 8 A drawing with load position marked.

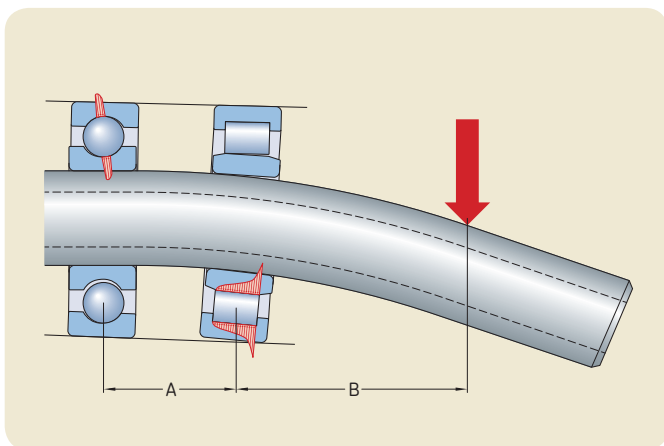

2.4 Shocks

A shock load is a load, often quite high, that has a very short duration. It needs to be compared to the static capacity of the bearing and should be expressed in Newtons. This isn't that easy since the shock load depends on the deceleration of the mass in movement ($F = m \gamma$) and, therefore, deformations in the mechanism.

Some designers choose to use oversized bearings or add more bearings. An example is vertical pulpers which experience shock loads that are difficult to estimate when recycled paper hits their rotors. Some manufactures prefer to use a spherical roller thrust bearing to accommodate the axial loads if they aren't using oversized spherical roller bearings based on known loads.

Shocks can also make rolling elements hammer the bearing cage. Consequently, the presence of repetitive shock loads will influence cage selection.

2.5 Vibrations

Vibration will have an influence on bearings. This is especially true during standstill when there is a risk of false brinelling i.e. rolling elements vibrating in the same position thereby creating fretting corrosion and wear. Vibration can also affect the lubricant. Grease can lose its consistency and move away from the bearing it's supposed to lubricate, for instance. As such, it's important to supply information on acceleration, amplitude and frequency (which are all linked to each other).

2.6 Accelerations

It's not just acceleration in terms of rotational speed than can make rolling elements slide rather than roll that needs to be considered. Centrifugal acceleration, where the centre of the bearing revolves around another component's axis such as in vibrating screens or planetary gearboxes, can also be important as it will influence bearing cage selection.

2.7 Speeds

Speeds and loads are key parameters, so a speed histogram is very useful information to have. Knowing only maximum speed can lead to lubrication issues. This is because a lubricant selected based on the maximum speed only may not build up an adequate oil film at lower speeds or run at too low temperature at minimum speed, so the grease may not bleed enough oil to correctly lubricate the bearing.

Long standstill periods should also be indicated as bearings can have false brinelling damage from vibration from other machines or standstill corrosion marks, for instance.

2.8 Requested rating life

Requesting too high a rating life can lead to costly bearing assemblies, seal designs and lubricating systems being selected. In addition, it's worth remembering that oversized bearings are more difficult to lubricate, have higher friction and will be more sensitive to low load.

Pulp and paper industry applications generally have a requested rating life between 30 000 and 200 000 hours. However, in my experience once L_{10h} is over 100 000 hours, the bearings start to be oversized and fail for reasons other than normal fatigue.

2.9 Available dimensions

Supplying available dimensions at the start of a study will allow a suitable bearing to be selected. That is a bearing that fits the available space and that can be mounting on the existing shaft.

2.10 Requested running accuracy

Please note that bearings with standard running accuracy are suitable for most applications. A few require increased running accuracy due to the speed or because a roll/cylinder or shaft needs to run very precisely.

Overestimating the need for increased running accuracy can be expensive. I remember a tissue mill in the 1990s requesting three micron running accuracy for an embossing calender in their converting plant. To meet this requirement I proposed preloaded spherical roller bearings, originally designed for printing machines, with a circulating oil system. The bearing seat on the shaft was a direct taper seat made with very tight tolerances and there was a special procedure to adjust the bearing preload. A few years later, a standard SKF spherical roller bearing was mounted following an unplanned failure and was found to have acceptable running accuracy. As the standard bearing wasn't preloaded, the friction was lower so grease lubrication could be used. Today the embossing calendar runs on standard SKF spherical roller bearings mounted on SKF withdrawal sleeves and is lubricated with multi-purpose grease.

2.11 Requested rigidity or maximum deformation

The different parts of a machine deform under load, so a maximum deformation might well be requested. For example, the shaft of a pinion in a bevel gear will bend under high torque deforming the support bearing and adjacent components and changing the position of the contact between the gear teeth. In such circumstances, the displacement of the pinion should be minimized in order to keep the gear mesh in the optimum range so that friction and temperature is reduced and gear life increased.

A way of increasing the stiffness is to preload the bearings. If we were to do this for our bevel gear example, a preload would be selected that balanced the need for gear mesh running accuracy and the operating temperature due to increased friction in the bearing due to the preload.

Note that a small bearing preload theoretically will increase bearing life in most cases, but be aware that the inherent increased friction can get out of control. Before applying preload to bearings it's best to talk to an SKF application engineer.

2.12 Requested maximum friction moment

Some applications may have special needs related to the rotational friction moment. Spreader rolls, for example. This has an impact on bearing choice, but also on lubricant and seal design selection. In the pulp and paper industry, this is mainly a concern for rolls that are driven by the paper web or felt.

2.13 Preferred lubrication method and lubricant

Sometimes a certain lubrication method or even a specific lubricant may be desirable. ISO VG 150 oil for a press roll in the wet section with an existing circulating oil system using that lubricant, for example. Or grease for a fan due to cost reasons.

With information about the preferred lubrication method and/or lubricant, an SKF application engineer is able to evaluate whether the operating conditions and bearings are compatible.

2.14 Temperatures

By temperatures, I mean ambient temperatures and operating temperatures than can affect the bearings e.g. air temperature in Yankee hood fans, steam temperatures in drying cylinders etc.

It's very important to provide realistic maximum and minimum temperatures. Please do not only give maximum temperatures for dryer section applications as it can lead to problems. For example, felt roll bearings being lubricated with high temperature grease which is suitable for the maximum temperature specified, but which may not be adequate for the lower rolls where the environment is cooler.

It's also important not to overestimate the steam temperature for drying cylinders, especially ones without journal insulation, as it can lead to recommending higher oil flow rates than necessary and the risk of leakage on some machines. There is also the risk that more expensive bearings with case hardened inner rings are proposed rather than standard bearings.

2.15 Possible contamination

Information about possible contamination from the environment or from the machine should be given as this will influence bearing, seal and lubrication selection.

Remember that contamination can occur during mounting (see issue 8 of SKF Pulp & Paper Practices for more information).

2.16 Mounting and dismounting requirements

In some cases, the space available to mount and dismount bearings can be limited. As such, it is good to know of any restrictions that could influence bearing assembly design and mounting/dismounting procedures.

The inner machine side bearing on an intermediate gear can be difficult to dismount, for example. Imagine a situation whether there is only 150 mm (5.9 inch) between gear casing and drying cylinder. The bearing assembly design and mounting/dismounting procedure needs to take account of this. Another example is replacing the bearing and adapter sleeve on a fan shaft that cannot be lifted much. If a split plummer block housing is used, it has to be mounted with the bearing, adapter sleeve and locking nut and pushed into place along the shaft. It is then not possible to use the SKF Drive-up Method since you cannot use a hydraulic nut to drive up the bearing.

3. Information needed for a root cause failure analysis

I often get phone calls like this: “Our fan bearing is overheating! We are spraying water on the housing to cool it down, but we still have to replace the bearings three times a month! What do you recommend?”

My answer is “it depends” followed by at least ten questions about operating conditions, bearing type and size, how it is mounted, what lubricant is used and so on. Most of the time this is met with silence as the caller cannot answer my questions. He didn’t mount the bearings or install the fan. The grease has been used successfully in other applications for years and he has no idea about the loads on the bearings. He called SKF because the fan’s user manual lists spare part bearings with SKF designations, so he thought we would know the operating conditions and how to fix his problem. Most often this is not the case as manufacturers have good design engineers who know their products and don’t call SKF to validate their bearing choices except in some tricky cases.

In such circumstances, I can recommend not spraying the housings with water since overheating bearings often have reduced internal clearance due to the inner ring being much hotter. If the housing and therefore the outer ring are cooled, it can lead to a bearing operating with no clearance and, with preload, overheating can quickly get out of control. I can also give some other recommendations like checking that excess grease can escape and recommend that SKF supervise the next bearing mounting. However, the caller usually ends up disappointed that I could not give him an immediate solution to his problem.

Doing a root cause failure analysis is a lot like a murder investigation. It helps if there is a body to do an autopsy on and it’s easier if it isn’t too badly damaged. Information about the body’s life can give clues, but sometimes the killer will remain unknown and the affair will join the cold cases in the archives.

For meaningful root cause failure analysis, as much information about the operating conditions as possible should be supplied (see section 2). Additional useful information includes: exact bearing

Fig. 9 Out of focus picture with flash reflections.



designation and markings, bearing operating temperatures (N.B. this is not the same as the temperature measured on the outside of the bearing housing), the service life of the previous bearing, mounting reports, brand and designation of lubricant, how the lubricant is supplied, bearing and lubricant storage time and machine modifications.

When a bearing is dismantled for root cause failure analysis, as much care as possible should be taken to avoid damaging it further as this can make it more difficult to ascertain the true cause of the

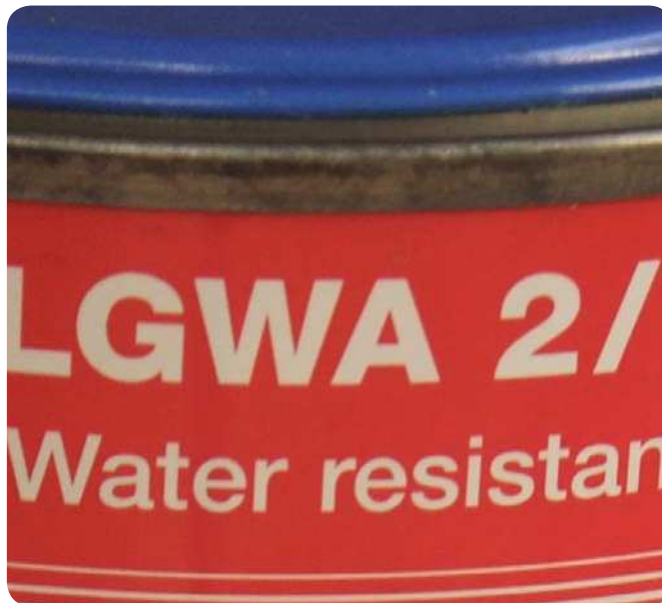
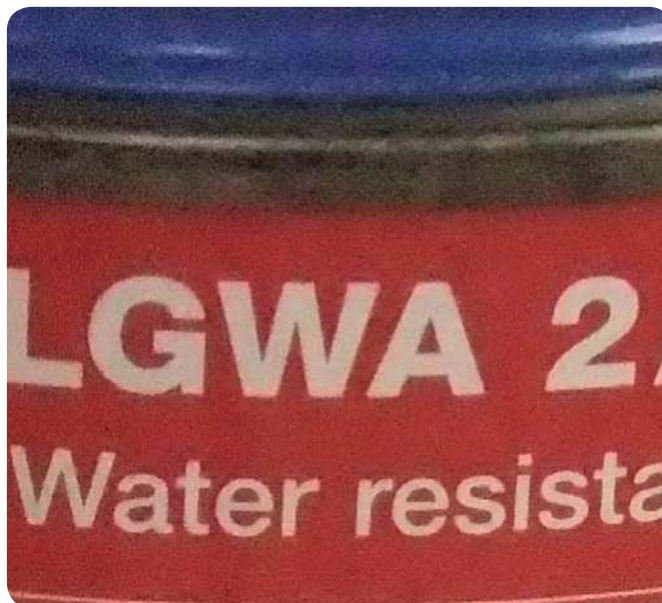

Fig. 10 Photograph taken with a compact camera set at 80 ISO.

Fig. 11 Picture taken with the same compact camera set at 1600 ISO. Be aware that in full auto mode the camera will use a high ISO to avoid low shutter speed and that there is a risk of blurred images if there is insufficient light.



problem. A sample of the lubricant from inside the dismantled bearing should be taken and then the bearing should be cleaned. Protecting it with preservative will help avoid corrosion or additional corrosion.

I'm fully aware that most customers will not have all the information listed above and that sometimes it's not even possible to supply the bearing designation. That said, the more information that can be supplied, the more likely the chance of a successful failure analysis.

Having the damaged bearing to examine is often central to an analysis. If it's not possible to send the bearing to SKF, good quality photographs can help ascertain the cause of the problem. If photographs are sent, they should include ones showing all elements of the bearing from all sides and not just the damaged parts.

Unfortunately, we often received photographs that are not very useful because they are out of focus and/or show flash reflections (see **figure 9**). This is a pity as you don't need an expensive camera to supply good photographs. Many small compact digital cameras and even some smart phone cameras are good enough.

Here are some tips for taking good bearing damage photographs:

- 1 Do not put your camera in full auto mode and don't use flash. Instead, use manual mode to control exposure and sensor sensitivity (ISO values).
- 2 Use macro mode if your camera has it.
- 3 Set your camera to its native ISO. This is often the smallest ISO number. High ISO will create noise that hides details (see **figures 10 and 11**)
- 4 Use a tripod and your camera's self-timer (see **figure 12**) in an area where there are several light sources so that shadows are avoided.
- 5 As cameras may not focus correctly on a steel surface due to lack of contrast, place a ruler next to the damage and focus on that (see **figure 13**)
- 6 After taking a photograph always look at it and zoom in to check that it is in focus.

Fig. 12 A compact camera on a tripod is usually good enough to take reasonable photographs of damaged bearings.



Fig. 13 If there is not enough contrast for your camera to focus properly, use a ruler and focus on the edge that instead.

There are other things that you can do like taking RAW instead of jpeg pictures and cropping images instead of using compression to reduce file size, but this is in danger of turning into a taking pictures tutorial. Simply following the six tips above should be good enough to start with.

As always, available space restricts me. I could write a lot more and spread it over two issues of SKF Pulp & Paper Practices, but I think that might be too much. I just hope that after reading this issue you understand calculated rating life, why SKF cannot predict the service life of an individual bearing and what information you should try to collect and supply the next time you want us to do a bearing study or root cause failure analysis for you.



Regards,
Philippe Gachet
Senior technical consultant
philippe.gachet@skf.com

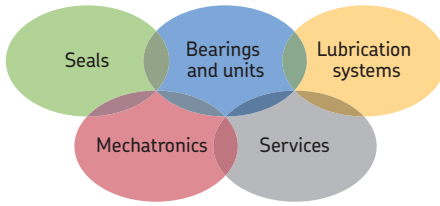

The Power of Knowledge Engineering

Drawing on five areas of competence and application-specific expertise amassed over more than 100 years, SKF brings innovative solutions to OEMs and production facilities in every major industry worldwide. These five competence areas include bearings and units, seals, lubrication systems, mechatronics (combining mechanics and electronics into intelligent systems), and a wide range of services, from 3-D computer modelling to advanced condition monitoring and reliability and asset management systems. A global presence provides SKF customers uniform quality standards and worldwide product availability.

SKF Global Pulp & Paper Segment

Contact/Responsible editor
philippe.gachet@skf.com

© SKF is a registered trademarks of the SKF Group.

© SKF Group 2013

The contents of this publication are the copyright of the publisher and may not be reproduced (even extracts) unless prior written permission is granted. Every care has been taken to ensure the accuracy of the information contained in this publication but no liability can be accepted for any loss or damage whether direct, indirect or consequential arising out of the use of the information contained herein.

PUB 72/S9 11147/8 EN - August 2013



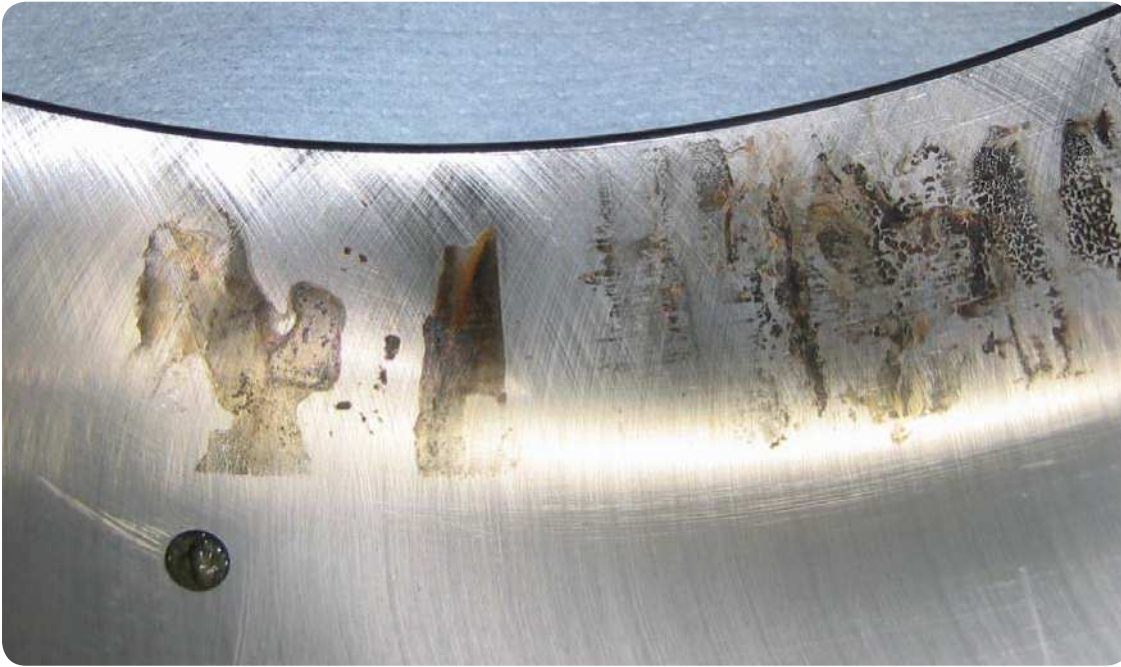

Standstill corrosion on a bearing due to process water contaminated grease.

Idled machines still need maintenance

Imagine that you are the proud owner of an expensive classic car. It drives well, but for some reason or another you need to leave it in the garage for a while. Months later, you charge the battery before trying to start it. To your delight it starts at the first attempt, so you decide to take it out for a drive. Everything goes well until you apply the brakes and discover you have a problem with asymmetrical braking. It was caused by the hydrophilic brake fluid and the resulting corrosion on your brake caliper pistons which no longer slide properly.

You were lucky. A lot of other things could have happened. Your tyres might have gone flat or the rubber could have degraded, your fuel could have evaporated leaving deposits in the tank, the fuel tank might even have developed a leak due to rust caused by free water in the petrol and so on.

Many of us have experienced such problems or know someone who has. The repair costs mount up and can be higher than the value of the car. The sad thing is that they could have easily been avoided if a few simple steps had been taken. Basic things like changing the brake fluid, emptying the fuel tank, turning the engine over every so often, taking the car out for a short drive once in a while etc.

By now, you're probably asking yourself what cars have to do with the machinery used in the pulp and paper process. The answer is simply that they all contain a lot of steel components that don't react very well to moisture.

As you know, it's not unusual for paper mills to stop production for long periods for rebuilds, overhauls or economic reasons. When this happens, remember the car left in the garage and that free water can cause standstill corrosion on bearings and other steel components in less than a day.

My experience is that most bearings on paper machines stopped for a few weeks will have a short service life unless preventive measures are taken. As such, this issue of SKF Pulp & Paper Practices contains recommendations on what to do during stops to prevent problems when machines are restarted.

Regards,
Philippe Gachet
Senior technical consultant
Philippe.gachet@skf.com



Restarting production after a long stop can be costly if you don't do it right

As many of you will remember, there were strikes in the Finnish paper industry a few years ago. Eventually, the parties involved came to an understanding and production was resumed. In the following months there was a significant increase in the number of incidents disrupting production and some of these were bearing related. This was hardly surprising as the frequency of failures when restarting machines is largely dependent on what precautions are taken before stopping them. If the precautions taken are insufficient, problems with corrosion and contamination are to be expected.

Over the years, SKF has seen hundreds of bearings that have failed after restarting production following prolonged stops. Most of them could have been prevented if the proper precautions had been taken beforehand. Given that market downtime is a reality for many markets and grades these days, we thought it would be useful to share some guidelines about preserving bearings during prolonged stops.

1. Causes of bearing damage during stops

The number one cause of bearing damage during prolonged stops in the paper industry is standstill corrosion. This is hardly surprising given the humid environment, the use of high-pressure cleaning, condensation forming in bearings and housings as they cool down and because bearings are predominantly made of steel and are therefore very sensitive to corrosion. Bearings are especially at risk during stops because water or process fluids easily separate from the lubricant (see **figure 1**) and cause damage (see **figures 2 and 3**)

The number two cause of damage is false brinelling. This is caused by vibration in the direct surroundings of a bearing that is not rotating. Due to this vibration, the rolling elements of the bearing are subject to micro-movements that free microparticles from the bearing raceways which corrode and act as an abrasive. The result is marks that look like indentations caused by pushing the rolling elements into the raceways, but with no burrs or displaced material (see **figure 4**).

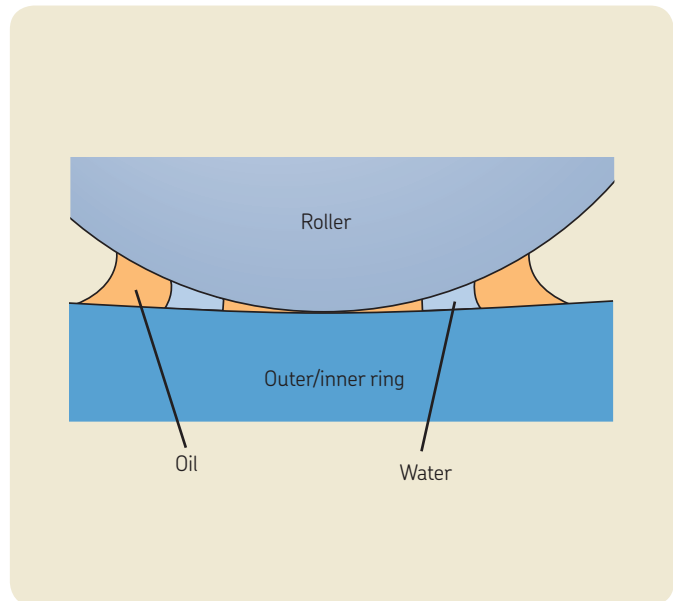

Fig. 1 Water or process fluids can easily separate from the lubricant.



Fig. 2 Standstill corrosion in a needle roller bearing from a tissue converting plant. The machine it was mounted on had been cleaned with high pressure water.

2. Preventing standstill corrosion

The actions recommended to prevent standstill corrosion vary according to the lubrication method that is used.

2.1 Grease lubrication

Over time, paper industry lubricants get contaminated with water from the process and the environment. To prevent this from having a negative effect, bearings and housings should be relubricated with fresh grease before the machine is stopped.

We recommend regreasing just before the machine is stopped because it is important that the bearings are rotating so that the grease can distribute itself into all the spaces and contacts in them. If, for whatever reason, regreasing takes place when the machine is stopped, the roll or cylinder that the bearing is mounted on should be rotated by hand.

For short maintenance stops, the normal regreasing procedure recommended by the machine supplier should be followed. For longer stops, the bearing should continue to be relubricated until excess fresh grease is purged from the housing. This should be readily apparent from the colour of the grease. With such an approach, it is important to remember that the temperature inside the housing when the machine is restarted may be higher than normal due to overfilling. However, excess grease will quickly be purged and the temperature will soon return to normal levels.

The fresh grease used should be suitable for the application and show a result of 0-0 with SKF Pulp & Paper artificial process water or with 0,5% NaCl in the SKF EMCOR test (ISO 11007/DIN 51802) for wet section applications, machines operating in a humid environment or those where the bearings could be contaminated with process water. A test result of 1-1 is acceptable for 0,5% NaCl in dryer section applications.

When centralised grease lubrication systems are used, fresh grease should be pumped through the pipes starting with the main lines, then the branches and finally the bearing housings and/or seals. Pipes can be disconnected at the connection points to verify that fresh grease is making its way through the complete line. This should be readily apparent from the colour of the grease.



Fig. 3 The outer ring of a spherical roller bearing that was mounted on a paper machine.



Fig. 4 An outer ring of a self-aligning ball bearing that has been subjected to false brinelling.

The SKF EMCOR test

SKF developed this test to measure the ability of a grease to protect a bearing against corrosion even with the presence of water. Testing is done in a dynamic way with bearings running and standing still. Even when the bearings are standing, the thin oil film left in the contact zone between the rollers and raceways must be able to protect the bearings against corrosion.

For more information about the SKF EMCOR test please contact your local SKF office or visit skf.com.

2.2 Oil bath lubrication

Oil analysis is strongly recommended and if the water content exceeds 200 parts per million (ppm), it needs to be changed. It is also important to discuss the analysis with the lubricant supplier to verify that the oil will protect machinery during prolonged shuts. For longer shuts, completely replacing the oil should be considered.

If no oil analysis is undertaken, we recommend changing the oil as soon as the machine stops and rotating the bearings on a regular basis. Doing this once a week, for example, will help to make sure that the oil is even distributed over the bearings and that all parts are covered.

The oil used should pass the SKF EMCOR test with a 0-0 result with distilled water and/or SKF Pulp & Paper artificial process water. Furthermore, anti-corrosion additives are recommended.

Note: Bearings that are lubricated with oil baths should be rotated periodically to allow the bearing elements to get a fresh coat of lubricant. How often this should be done depends on the ambient conditions and will vary from once a week to once per month.

2.3 Circulating oil lubrication

The water content of the oil should be no more than 200 ppm before the machine stops and, once again, an oil analysis is strongly recommended. As with oil bath lubrication, it is important to discuss this analysis with your lubricant supplier to verify that the oil will protect machinery during prolonged shuts.

It is advisable to keep the lubrication system running to avoid failures at a later date though the flow rate can be reduced. If the machine is stopped for a long time, we advise running the system at full flow rate at regular intervals and checking the flow meters until you are confident that oil has circulated throughout the system and returned to the reservoir tank.

The water content of the oil should be kept to a maximum of 200 ppm to avoid corrosion problems. This is particularly important if carbonised iron lubrication piping is used.

As for oil bath lubrication, the oil used should pass the SKF EMCOR test with a 0-0 result with distilled water and 1-1 with artificial process water or the mill's actual process water. Lesser anti-corrosion properties can be accepted since the system should be in operation on a regular basis and the water content controlled. If this is not the case, the same advice as for oil bath lubrication should be followed.

3. Preventing false brinelling

Sources of vibration like stationary engines should be removed or not operating while the machine is stopped. To further reduce the risk, it is advisable to rotate the bearings at regular intervals. This can be achieved by rotating the roll/cylinder. How often this should be done depends on the vibration levels that are created by the surrounding machinery, but can be once per week or even more frequently.

4. Piping

A number of lubrication system piping related problems can occur during stops. For example, it is not always made of stainless steel and, as such, there is a substantial risk of corrosion inside the pipes while the lubrication system is not in use. This can lead to problems with corroded particles being transported to the bearing by the lubricant when the system is restarted.

Impurities in the lubricant can settle when circulating oil systems are not in use and may cause blockages when they restart. With grease lubrication systems, the lubricant can harden during prolonged stops and cause blockages whose exact location can be hard to detect.

5. Restarting machines when standstill advice has not been followed

As we explained earlier, if a machine is stopped without taking precautions there is a risk when it is restarted of bearing failures due to corrosion, blocked lubrication pipes and so on. However, even in such cases there are some actions that can be considered to minimize the associated impact on costs and production.

It may be necessary to replace all the bearings. While this sounds very time-consuming and costly, it can be worth it in the long run. To minimize the costs involved, dismantled bearings can be sent to your local SKF Solution Factory for inspection and possible repair. Those bearings that can be restored by polishing and grinding can be reused. This will offer significant savings over buying new bearings.

Lubrication pipes that are not made from stainless steel should be replaced. The risk is that they will be corroded inside and there is no way for them to be repaired. While this is a major undertaking, the benefits in terms of production time saved should outweigh the costs involved.

Stainless steel lubrication pipes should be checked for blockages. If any are detected, it may be possible to remove them by flushing with a solvent after first disconnecting the piping from the circulating oil system and bearing housings. Some mills decide to take the risk and run the machine while monitoring the flow meters though SKF does not condone this approach due to the risk of lubrication starvation and subsequent associated damage.

Consider replacing the return pipes even if they are made from stainless steel. They are at the wrong side of the bearing. While feed pipes contain clean oil that has been filtered, the return pipes contain oil with contaminants and wear particles. When the machine is stopped, these will settle. To clean these pipes will probably mean that you have to flush – likely back towards the bearing – and risk contaminating it. The alternative is to disconnect return pipes, which are generally larger than the feed pipes, and connect each one to a pump. It's normally safer and more economical to simply replace the return pipes and avoid the risk of failures due to contamination.

Think twice before flushing lubrication systems. Over the years particles will have accumulated in dead spots and flushing may force them into the lubrication system again. Furthermore, the flushing fluid may stay in the circulating oil system for some time and even if it is compatible with the oil, it's unlikely to be the best thing to lubricate bearings with. If, having read this, you are still considering flushing your system, contact the lubricant supplier for advice on what fluid to use.

Clean the oil sump. At most mills I visit, they are cleaned once a year during the annual stop. They should also be cleaned before restarting a machine after a prolonged stop. Oil bath systems need attention as well. We advise draining the sump, cleaning it and refilling it with fresh oil.

Run your circulating oil systems for around 15 minutes and check that all lines are feeding by checking the flow meters or sight glasses before restarting your machine. This helps ensure that all bearings are properly lubricated before they start rotating. If this is not done, there is the risk that they will run dry or with insufficient lubrication which may lead to subsequent failures later on.

Pump all grease lubrication points through until fresh grease is purged from the seals or drain holes before start-up. This should be done via the normal grease point to check that everything is functioning normally and that there are no blockages. The reason we recommend this is because the grease may have "bled out" during standstill. When this happens, some of the oil has leaked out of the grease and what is left is a partially dried up soap than can block pipes, nipples and even bearings. If it is done properly, the bearings will be overfilled and it is advisable to start the machine slowly so that surplus grease is purged over the course of several hours without large temperature increases. In some cases, the bearing housing will need to be opened up and surplus grease removed manually.

Start the machine slowly after a long standstill. Gaskets and stuffing boxes may have dried out and opened up. With a slow start they have a chance to readjust. If not, at least you are able to locate and replace them before a large amount of oil has leaked out.

In conclusion, paper machines can be restarted without too many major mechanical problems after a prolonged stop if appropriate standstill preparations were taken. Even if they were not, there are a number of actions that can be taken to mitigate the effects. Too many companies, in my experience, are so eager to get started again that they neglect to do these things. This can often be a costly mistake.

If you are ever in the situation that you need to shut down one of your machines for some time, we recommend following the advice given in this article to avoid unnecessary and costly maintenance before restarting your machine.

Regards,
Rene van den Heuvel
Maintenance Solutions Manager
rene.van.den.heuvel@skf.com



Small things can matter

When you visit a paper mill workshop, you'll often find a stack of pulleys somewhere on the shelves. They're actually rope sheaves from the tail threading system which guides a strip of paper through the paper machine at the start of production (see figure 5). You might wonder, as we did, why so many of them are lying around?

Part of the reason is that a paper machine can have as many as 200 rope sheaves. They're only needed at the start of production and serve no purpose once the tail threading process is complete. Nevertheless, they still keep running and at considerable speeds. A 200 mm core diameter sheaves on a paper machine with an operating speed of 600 m/min can be running as fast as 955 r/min, for instance.

Rope sheaves – operating conditions and challenges

Most rope sheaves have a very simple design. They're simply a metal pulley, with two ball bearings in the hub, mounted on a shaft (see figure 6). The shafts are mounted on paper machine frames and, therefore, the bearing inner rings do not rotate. Bearing outer rings, in contrast, are fixed in the hub of the sheaves and do rotate.

The most commonly used ball bearings in this application have a 35 mm bore diameter. Under ideal conditions, 70 °C on a horizontal shaft with radial load in a clean environment, such bearings only need to be relubricated every 20 000 hours which means once every

27 months. In reality, the conditions in a paper mill are far from ideal.

In the wet section, temperatures are acceptable, but the humidity is high. During production and cleaning, the sheaves are exposed to water and the damp environment. With a 27 month relubrication interval, there are lots of opportunities for bearings to corrode and for lubrication films to be rendered ineffective.

In the dryer section, the conditions are more difficult. It's hotter with an average ambient temperature of 100 °C and there's a lot of dust. For every 15 °C over 70 °C, the relubrication interval needs to be halved. This means relubricating the sheaves in the dryer section every six months instead of every 27 months. The dust causes its own problems. It collects on the shaft and the hub (see figure 7) and can act as a wick that drains the oil out of the grease.

In general, many rope sheaves are in inaccessible locations on the machine. This often leads to them not being relubricated resulting in lubricant starvation for the bearings. Even when they are, it's quite common for them to be over-greased and for surplus grease to end up on the hub, the floor or the paper.

Fig. 5 The tail threading process.

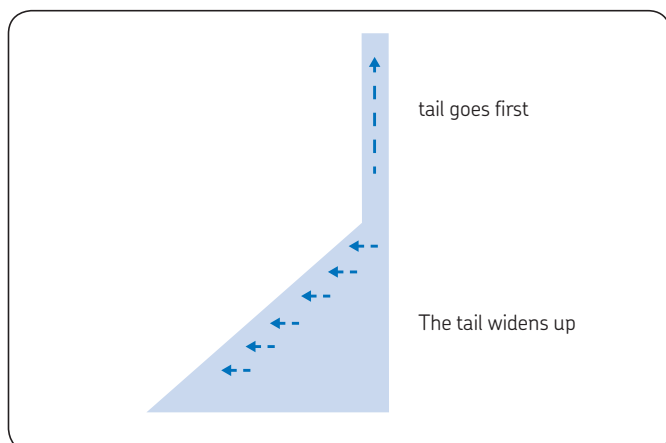
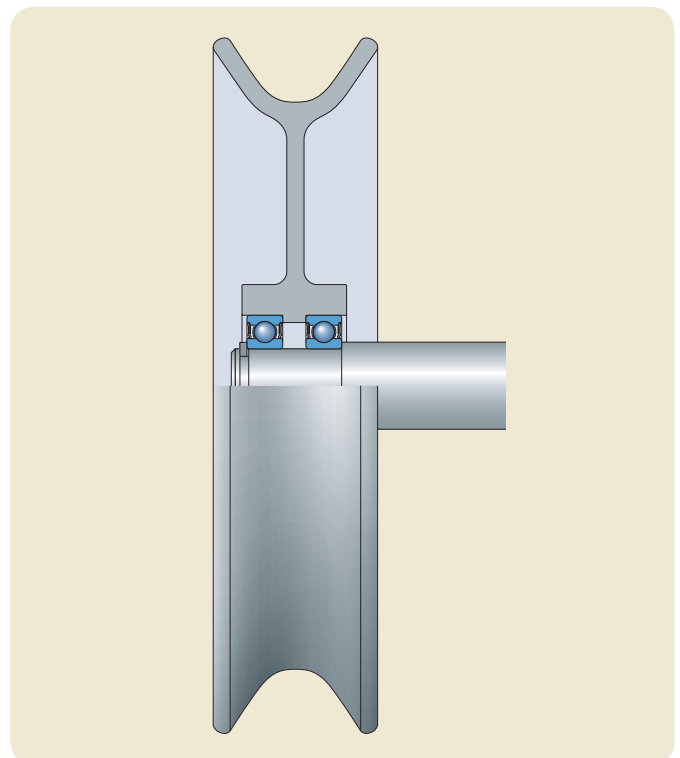

Fig. 6 Rope sheave bearing arrangement.



Unfortunately, rope sheave failures can be quite difficult to detect and normally sheaves are not part of a mill's vibration monitoring routes. While ones that have stopped rotating are the easiest to spot, those that are still moving, but not at the required speed, are much more challenging. This is a problem because it can cause rope wear and, in extreme cases, sheaves can drop off their shafts. As well as being a safety hazard this risks damaging machine parts, wires or fabrics.

Failed or failing sheaves are often only detected during tail threading. They can lead to tail breaks with several attempts necessary to get production started. In some cases, cleaning the machine is necessary, which leads to extra downtime. Consequently, many mills replace sheaves at every stop.

Sheaves that have been in operation for weeks or months are dismantled from the machine and have their bearings replaced. This happens in the workshop which is why they can be seen lying around so often. As new ball bearings are relatively cheap and because replacing them is not a lot of work, it's generally not seen as a problem. However, with time and bearing replacements, the hubs and shafts of the sheaves start to wear out. Once they are outside the required tolerance range, replacement bearings will start to creep (turn) in the hub or on the shaft and bearing service life will be significantly reduced.

On average, it takes two men two hours to replace a rope sheave. Some mills replace 10–15 sheaves per quarter which would mean 40–60 replacements and 160–240 man hours per year. Add in the time needed to mount new bearings in existing sheaves, any extra downtime resulting from rope sheave problems and possible safety issues and you have a fairly costly situation. Costly enough for some mills to have sought a better solution.

The SKF solution

In 2001, Stora Enso Kvarnsveden approached SKF in Sweden about a problem they'd experienced with a dryer section rope sheave. Due to a bearing failure, the sheave fell six metres and narrowly missed hitting one of their workers.

After investigation, SKF concluded that the bearing failure was predominantly related to lubrication and sealing issues. In addition, they found that the combination of outer ring rotation and high rotational speed created centrifugal forces which forced grease out of the bearings.

SKF developed a solution with a static outer ring and inner ring rotation. A deep labyrinth seal combined with bearing seals were designed in to protect the bearings. Ceramic balls were used in the bearings to increase the relubrication interval and a high performance grease, suitable for the application, was selected. The new rope sheave units were designed in such a way that existing sheaves could be modified. For rope alignment purposes, an adjustable angle unit was developed. Finally, the new units had a patented lock to stop sheaves falling in the unlikely event of bearing failure.



Fig. 7 Dust collects on shafts and hubs.

Tests were successfully completed in the same year and Stora Enso immediately replaced 68 sheaves with the new SKF rope sheave units (see **figure 8**). The new units run for four years before there is any need for inspection (Note that this is in the dryer section of a fast machine and that with more favourable conditions longer service lives have been achieved). If necessary, they can be refurbished with replacement bearings, grease and seals. The other parts can be reused which, over time, leads to substantial cost savings.

The new generation

Following the success of the original SKF rope sheave units, a second generation unit was developed with improved sealing and a lower price. In addition, it was possible to reduce the sheave core diameter from the 150 mm of the original design to 110 mm on the new one (see **figures 9** and **10**).

The basis of the design is an SKF car hub unit. After all, if they can withstand water, mud, salt, heat, cold, high pressure cleaning, high rotational speeds, high axial forces and shock loads, why not use them as the basis for rope sheaves on paper machines? Some modifications were made, of course. The metal balls were replaced with ceramic ones and the high performance grease used in the original design was selected.



Fig. 8 The SKF rope sheave unit in operation.



Fig. 9 New generation SKF rope sheave unit.



Fig. 10 New generation SKF rope sheave unit in operation.

Due to the design, units with two or more independently running sheaves are now possible (see **figure 11**). This creates a wide range of application possibilities for the paper industry.

If, after many years of trouble-free operation, the unit needs to be replaced, the sheave and shaft can be reused (see **figure 12**). Only the bearing hub unit needs to be replaced, which is supplied fully assembled and ready to be used.

In conclusion, our experience – and that of the mills using our rope sheave units – is that apparently minor problems such as rope sheave failures can have a surprising impact on maintenance and production. Also that install and forget solutions allow people to focus on other higher priority issues that need addressing. That said, it's usually worth trying to eliminate problems that use lots of resources or impact on production. It's all part of reliability improvement which is something that SKF is always happy to help with.

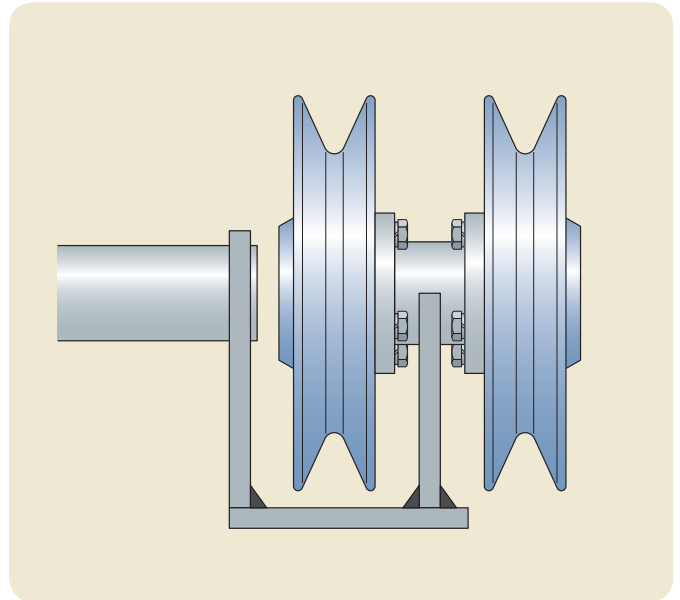

Fig. 11 A double independent unit.



Fig. 12 The sheave and shaft can be used again.

Regards,
Rene van den Heuvel
Maintenance Solutions Manager
rene.van.den.heuvel@skf.com



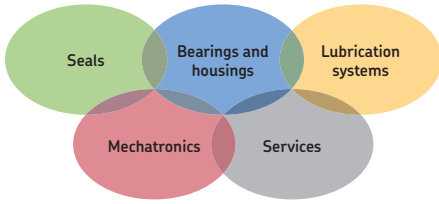

The Power of Knowledge Engineering

Combining products, people, and application-specific knowledge, SKF delivers innovative solutions to equipment manufacturers and production facilities in every major industry worldwide. Having expertise in multiple competence areas supports SKF Life Cycle Management, a proven approach to improving equipment reliability, optimizing operational and energy efficiency and reducing total cost of ownership.

These competence areas include bearings and units, seals, lubrication systems, mechatronics, and a wide range of services, from 3-D computer modelling to cloud-based condition monitoring and asset management services.

SKF's global footprint provides SKF customers with uniform quality standards and worldwide product availability. Our local presence provides direct access to the experience, knowledge and ingenuity of SKF people.

SKF Global Pulp & Paper Segment

Contact/Responsible editor
philippe.gachet@skf.com

© SKF is a registered trademarks of the SKF Group.

© SKF Group 2014

The contents of this publication are the copyright of the publisher and may not be reproduced (even extracts) unless prior written permission is granted. Every care has been taken to ensure the accuracy of the information contained in this publication but no liability can be accepted for any loss or damage whether direct, indirect or consequential arising out of the use of the information contained herein.

PUB 72/S9 11147/9 EN - February 2014





SKF technician checking bearing seat geometry with an inner ring and Prussian blue

The power of knowledge and getting your hands dirty

It's not that easy to create an issue of SKF Pulp & Paper Practices because our readers range from maintenance workers in mills to engineers and designers at equipment manufacturers. This makes it a challenge to write content which appeals to everyone. While a piece about how to measure clearance with a feeler gauge is likely to be interesting for fitters mounting bearings, it's going to be less relevant for design engineers concerned with selecting and calculating the correct interference fit for bearings.

One reader recently told me that the first few issues of *SKF Pulp & Paper Practices* were very interesting, but he stopped reading them after that because he felt the trend was towards more information for those working with bearings on their computer screens and less tips for those with them in their hands. With this in mind, I decided that issue 11 would be written primarily for those with their hands in the grease.

Engineers and designers will hopefully find this issue useful too. After all, how can you design a bearing assembly without an understanding of the reality of mounting and the time pressure on maintenance workers during a machine stop? In my time, I've seen many arrangements where changing the bearing was both time-consuming and costly. While some of them were probably the result of trying to

reduce cost, others were almost certainly because bearing replacement had not been properly taken into account.

Just as understanding mill realities helps engineers and designers, knowing the basics of what happens to bearings during operation is useful for maintenance workers. Such knowledge can help avoid many common causes of bearing failures such as overfilling with grease, excessive clearance reduction and so on. To reassure any nervous readers, I'm talking about a basic understanding rather than knowing all the formulas and running the calculations.

The marriage of practical experience and theoretical knowledge is very powerful. The gentleman in the photograph above, Belaid Ait Hamouda, and I mounted many bearings together. I think we made a good team and we certainly learnt a lot from each other. Unfortunately, some still believe that you just need to know how to use a spanner or tighten a screw. These people badly underestimate the value of well-trained, knowledgeable and experienced mechanics.

Regards,
Philippe Gachet
Senior technical consultant
Philippe.gachet@skf.com



Just some tips

This issue of SKF Pulp & Paper Practices will focus on sharing knowledge about:

- 1 Mounting tapered bore bearings on hot journals
- 2 Checking internal radial clearance on CARB toroidal bearings
- 3 Increasing drive-up to compensate for wear and/or increased clearance
- 4 How to check whether a nut is tightened to the correct torque.
You'd be surprised at how many mechanics and engineers get this wrong!



Fig. 1 SKF TIH L induction heater for bearings up to 800 mm bore diameter and 1 200 kg weight e.g. many Yankee cylinder bearings.

1. Mounting tapered bore bearings on hot journals

There is not always enough time during unplanned stops or short planned stops to mount bearings using methods that would be preferred if there was less pressure to do things fast. In such cases, there can be issues related to giving journals and replacement bearings sufficient time to reach ambient temperature.

Driving up a cold bearing on the taper seat of a hot shaft and adjusting the interference fit while the bearing inner ring and shaft are at different temperatures will result in less of a tight fit than if they were at the same temperature. This can lead to fretting corrosion in the contact surface between the inner ring bore and the taper seat. In some cases, the inner ring will rotate on the shaft creating wear, smearing marks and fractures.

One solution is to place the bearing on its seat and to let the inner ring heat up to the shaft temperature. There should be no need to use a thermometer if the shaft temperature is below 55 °C as you can get an approximate, yet adequate, idea of the temperature difference by feel. However, when the clock is ticking, production colleagues are not going to be happy to see maintenance staff taking a coffee break while the inner ring slowly reaches the shaft temperature.

When time is of the essence, the fastest and most accurate solution is to heat the bearing up to the shaft temperature with an induction heater (→ **figure 1**). Such heaters are easy to use.

Simply:

- 1 Place a suitable induction heater close to the machine while the housing is opened or dismantled to allow access to the bearing that needs to be replaced.
- 2 Put the new bearing on the induction heater.
- 3 Dismount the bearing being replaced and measure the shaft temperature of the bearing seat with a thermometer.
- 4 Heat the new bearing up to the measured shaft temperature and then place it on the shaft without delay.
- 5 Drive-up the new bearing to obtain the desired fit.

N.B. A suitable induction heater is one that is an adequate size for the bearing and which has an automatic demagnetization feature. The latter is important to prevent ferrous debris from contaminating the new bearing.

Unfortunately, not all paper mills have induction heaters. I still visit some where they heat bearings in an oil bath like in the old days. I would never recommend this as there are many drawbacks. For a start, it's too slow and imprecise. Furthermore, there are health and safety concerns. There's also a risk of contaminating new bearings with old, dirty oil.

People without access to induction heaters often ask me how to adjust drive-up. With the temperatures of the bearing inner ring and

the bearing seat you can calculate the increased tight fit needed to compensate for the difference. Consider a bearing inner ring of bore diameter 400 mm at 20 °C and a shaft at 60 °C i.e. a temperature difference of 40 °C. The coefficient of thermal expansion is 1,05 mm per metre per 100 °C for cast iron and 1,2 mm per metre per 100 °C for steel. While the bearing inner ring is made from steel, the cylinder or roll journal could be either steel or cast iron. To make it simple – and because the inner ring will start to heat up as soon as it's in contact with the hot seat – let's use 1 mm per meter per 100 °C. In this case, there's a need to the drive the bearing up further so that it seats on a larger diameter giving a tight fit that will decrease when the inner ring and the journal reach the same temperature. The question is how much further?

With a coefficient of thermal expansion taken as 1 mm per meter per 100 °C, a temperature difference of 40 °C and a diameter of 0,4 metres, we have 0,16 mm in excess of the diameter. If the bearing is a K bore variant – that is one with a 1:12 tapered bore – the additional axial increase should be $0,16 \times 12 = 1,92$ mm. For K30 variants with 1:30 tapered bores, the additional axial increase should be $0,16 \times 30 = 4,8$ mm. These seem large compared to normal recommended values, don't they?

A 23180 CAK/C4W33 mounted on a Yankee cylinder with a 200 mm journal bore has an axial drive-up using the SKF Drive-up Method of 2,6 mm (→ **figure 2** and *SKF Pulp & Paper Practices issue three*). Using the calculation method in the previous paragraph would call for around an additional 2 mm of axial drive-up. This should raise the question of the whether the bearing can withstand

this without cracking the inner ring. The answer is yes in this particular case.

As soon as a bearing is in contact with a hot seat the temperature difference between the two reduces quickly before gradually slowing down as temperatures equalise. It is possible to measure journal and inner temperatures during mounting and adjust the axial drive-up. Could I recommend an easy rule of thumb such as driving up half the calculated value? I did it once to save time, but I really don't recommend it.

For those using feeler gauges who want to know how much more clearance reduction is needed to compensate for the temperature difference between a bearing and its seat, I advise using the SKF Drive-up software and selecting "Other" in the clearance reduction section. The clearance reduction value Δ_r should be changed until the drive-up value S_s equals the normal drive-up value plus the additional drive-up due to the temperature difference between the bearing and its seat. For those who think that this is too complicated and/or imprecise, I can only recommend buying SKF induction heaters and adjusting the bearing fit on its seat as you do when the machine is cold and the bearings and shaft seats are at the same temperature.

Fig. 2 Screenshot of SKF Drive-up software calculation for a 23180 CCK/C4W33 mounted on a tapered journal (like on most modern Yankee cylinders).

2. Checking internal radial clearance on CARB toroidal bearings

I showed in issue one of *SKF Pulp & Paper Practices* that checking the radial clearance of a spherical roller bearing isn't easy. I also mentioned that it is more difficult for CARB toroidal bearings and stated that "we do not recommend that the feeler gauge method should be used when mounting a CARB toroidal roller bearing unless the fitter is well trained and very experienced." Let me explain why.

Just like for a spherical roller bearing, the rollers on a CARB toroidal bearing must be in their equilibrium position as if it was in rotation under load. With a spherical roller bearing, one ring must be rotated and to reach the approximate equilibrium position (if the rollers cannot find it themselves) you should simultaneously slightly push two neighbouring rollers, one from each row, against the floating guide ring. In contrast, a CARB toroidal bearing has one row of rollers, no guide ring and moves in various directions to accommodate misalignment and axial displacement. This makes it difficult to find the roller equilibrium position. Once you believe that the rollers are centered and the inner and outer rings are aligned, you check the radial clearance with a feeler gauge. The chances are that you will find, like most people, a much smaller clearance than there actually is.

I have a C 3040 CARB toroidal bearing in my office and like to challenge colleagues and visitors to try and find the actual internal clearance with a feeler gauge. So far, nobody has managed to do so. This is not due, as some believe, to the rings not being precisely enough aligned (since axial displacement of the inner ring relative to the outer ring reduces clearance). The relationship between radial clearance and axial displacement of one ring relative to the other can be seen in **figure 3**.

Note that the curve between zones **I** and **II** in **figure 3** represents the boundary between clearance and no clearance. As you can see, a radial clearance of 0,082 mm without any axial offset between the inner and outer rings allows an axial displacement of one ring relative to the other of 8,20 mm before there is no clearance. If, under the same conditions, radial clearance was 0,328 mm, the permissible axial displacement would be 16,40 mm.

If there is 0,328 mm radial clearance without axial offset and there is 8,20 mm axial displacement of one ring relative to the other, the remaining radial clearance would be $0,328 - 0,082 = 0,246$ mm. A small radial clearance can give a large possible axial displacement (\rightarrow **figure 4** and **5**). Note that a small axial displacement (± 2 mm for C 3040) around the zero axial displacement position gives very, very little clearance reduction. So, if the two rings of the bearing are aligned by eye, it is sufficient.

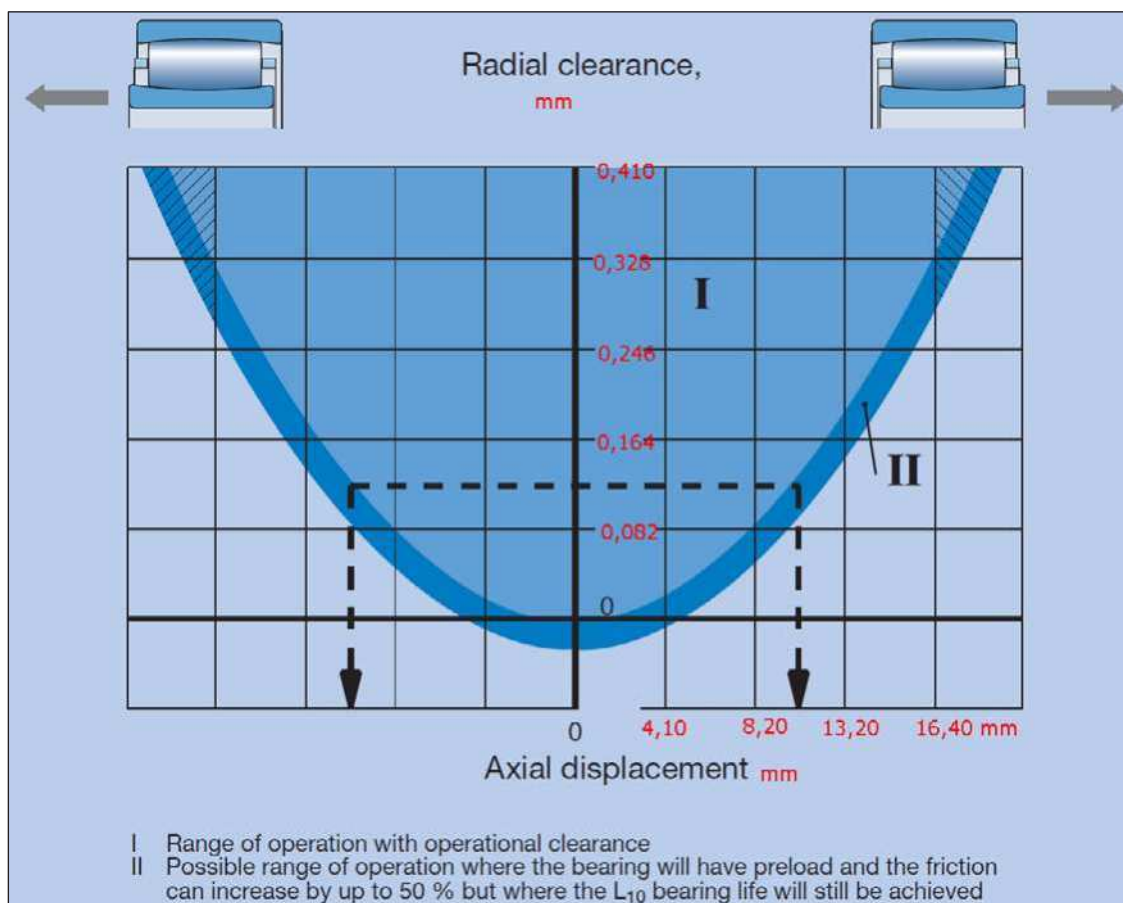

Fig. 3 Relationship between radial clearance and axial displacement for a C 3040 CARB toroidal bearing.

The important thing is the axial position of the rollers in the bearing (see **figure 6** which explains this better than words can do).

A small axial displacement of the roller away from its central equilibrium position will change the clearance along the roller profile. If the clearance is measured with a feeler gauge and you try to pass it over the middle of the roller you will find a smaller clearance than there is in reality. To approach the true clearance, you need to move the roller back and forward with your fingers while you try to pass the feeler gauge between roller and ring without forcing it. You will notice that initially it doesn't want to pass and then it will suddenly do so easily. You can then take a thicker feeler gauge and repeat the same process until it passes with slight friction.

The real issue is that most workers do not have enough experience of checking the radial clearance of CARB toroidal bearings with feeler gauges. This can be problematic when mounting small bearings on a taper seat without a hydraulic nut as hitting the lock nut to push the bearing along the seat will make the rolling elements move and it takes more experience to put CARB components back in position than it does for a spherical roller bearing. As a result, many small CARB toroidal bearings are mounted either too tight or too loose. Furthermore, if the clearance after mounting is checked by another worker, my experience is that he will invariably believe that there is a lower clearance than there is in reality.

To be frank, the best way to avoid the issues that I've described is to mount CARB toroidal bearings using the SKF Drive-up Method or, if the bearing is large enough, with SKF SensorMount. If there isn't the space to use a hydraulic nut, as is often the case with some fans, use the nut rotating angle method just like you would for a self-aligning ball bearing.



Fig. 4 Inner and outer rings aligned, roller in the equilibrium position and limited radial clearance. Note the scale is in cm.



Fig. 5 With the radial clearance shown in figure 4 the possible axial displacement of one ring relative to the other is important. Note that under certain operating conditions the load distribution along the roller profile allows part of the roller to run outside the raceway as shown.



Fig. 6 Axial displacement of the roller leads to uneven clearance over the roller length.

To reiterate, I do not recommend mounting a CARB toroidal bearing with the feeler gauge method unless you are experienced. You can train yourself by trying to find the real clearance on a medium sized CARB. How? It's quite simple, really. You need a ruler or straight edge and either a vernier caliper or another tool to measure the relative offset between the inner and outer rings (→ **figure 7** and **8**).

Measurements should be taken in at least four positions that are 90° from each other. To minimise inner ring versus outer ring misalignment, check that all roller faces are equidistant from the edge of the outer ring. This is not that easy since the rollers supporting the inner ring do not move at the same time as the others when you pull the inner ring axially. If the bearing gets blocked in one position, don't push the inner ring back. Simply rotate the inner ring (→ **figure 9**)

Once all the measurements have been taken, calculate the average. In the case of my C 3040 CARB toroidal bearing, the average was 13,8 mm. In the *SKF rolling bearings catalogue* (publication number 10 000) there are equations for the relation between the axial displacement and radial clearance when the inner and outer rings are aligned.

$$S_{cle} = \sqrt{\frac{2 B C_{red}}{k_2}}$$

$$C_{red} = \frac{K_2 S_{cle}^2}{B}$$

S_{cle} = maximum axial displacement from a centered position, corresponding to a certain radial clearance reduction (mm)

C_{red} = reduction of radial clearance as a result of an axial displacement from de centered position (mm)

B = bearing width in mm

K_2 = operating clearance factor that can be found in the product tables in the catalogue.

For the C 3040 :

B = 82 mm

K_2 = 0,095

So if $S_{cle} = 13,8$ mm, then:

$$C_{red} = \frac{0,0095 \times 13,8^2}{82} = 0,220 \text{ m}$$

The real bearing radial clearance is then 0,220 mm.

You can now train yourself to measure the bearing clearance with a feeler gauge. Challenge your colleagues to measure the clearance and bet that they will find a value below 0,220 mm. I would expect between 0,140 and 0,190 mm.



Fig. 7 Using a ruler and a vernier caliper to measure inner ring versus outer ring axial offset I.



Fig. 8 Using a ruler and a vernier caliper to measure inner ring versus outer ring axial offset II.



Fig. 9 Rotating the inner ring to free up a bearing blocked by too much axial displacement.

3. Increasing drive-up to compensate for wear and/or increased clearance class

Sometimes, for various reasons, a bearing with a greater than desired clearance class has to be mounted e.g. C4 rather than C3. In such cases, I'm often asked whether it's possible to drive the bearing further up on its taper seat to reduce the radial clearance.

My normal recommendation is not to increase the drive-up. The reason being that it will increase hoop stress in the inner ring and the bearing service life could be reduced since micro cracks caused by fatigue and surface damage will propagate more quickly. In extreme cases, it will increase the risk of ring fracture. That said, remember that:

- 1 There can be a small increased clearance compared to the original recommended clearance class e.g. 23152 CCK/C3W33 has an unmounted radial clearance between 0,300 and 0,390 mm while a 23152 CCK/C4W33 has an unmounted radial clearance between 0,390 and 0,490 mm. So, if a 23152 CCK/C4W33 has a radial clearance before mounting of 0,410 i.e. just 0,020 mm above C3 clearance class range, only a small increase of drive-up is needed to make it operate like a C3 clearance class bearing. Calculations can be made to estimate the hoop stress increase caused by the radial clearance reduction increase.
- 2 For a given radial load, the bigger the clearance in the bearing, the higher the load on the most loaded roller and fatigue life is reduced (see issue two of *SKF Pulp & Paper Practices*). There is a balance to be achieved between increased hoop stress, which reduces life when driving up the ring harder, and the reduction of clearance which gives a better load distribution on the bearing rollers and a longer life.
- 3 Many other manufacturers' spherical roller bearings are made from standard martensitic heat treated steel. In contrast, SKF spherical roller bearings and CARB toroidal bearings are mostly made from bainitic heat treated steel. While martensitic steels have tensile hoop stress near the surface, bainitic steels have compressive hoop stress. Those being case hardened have compressive hoop stress as well. This allows them to withstand higher hoop stress resulting from increased drive-up.
- 4 Adjusting drive-up with the feeler gauge mounting method isn't very accurate and can lead to quite a wide spread of resulting fit values. There is a risk of too tight fits. This can be avoided by using the SKF Drive-up Method or the even more accurate SKF Sensor-Mount method. More information on both of these can be found in issue three of *SKF Pulp & Paper Practices*.
- 5 For some applications such as suction press rolls, where bearings are mounted on large hollow journals and the journal bores are close to 80% of their external diameter, high drive-up is needed to prevent fretting and creeping between the bearing and the journal. Normally, the clearance reduction is around 0,065% of the bearing bore diameter (cf. the 0,050% generally recommended for pulp and paper applications). With more accurate mounting methods like the SKF Drive-up Method and SKF SensorMount, we can accept higher drive-up values.

In conclusion, increasing drive-up to reduce radial clearance in a bearing can have a positive effect on its service life. However, the risk is that if the feeler gauge method is used and the points listed above are not considered, service life will most likely suffer and the chances of ring fracture will increase. It is for these reasons that we generally do not advise driving up further than recommended.

4. Checking that bolts are tightened to the correct torque

When a nut or bolt is tightened it's not possible to check that it's at the correct torque value without unscrewing it and retightening it to the correct value. A common mistake is to set a torque wrench to the recommended value and check that the nut/bolt does not move when this is reached. The error is believing that it has been tightened to a value equal to or greater than that recommended.

In reality, the nut/bolt can be below the recommended torque value if checked using this method. This is because the coefficient of friction in the threads and at the contact surface between the nut/bolt head and its supporting surface varies depending on whether there is sliding or not. This is exactly the same phenomenon as the stick-slip axial movement of the non-locating spherical roller bearing that displaces under thermal expansion of the cylinder (see page six, issue six of *SKF Pulp & Paper Practices*).

The torque value when tightening is obtained when there is movement so the coefficient of friction when sliding (μ_{sl}) must be taken into account. Once the nut/bolt is tightened and doesn't move a higher torque value than the one set on the wrench is needed to make it turn again. This is because the coefficient of friction when there is adhesion (μ_{ad}) needs to be taken into account and μ_{sl} is smaller than μ_{ad} .

Finally, as a reminder, please remember that the final actual tightening value depends not only on torque wrench accuracy and set value, but also on the surface conditions (roughness, whether there's any damage or not), the type of coating (if there is one) and the lubrication of the thread and the nut/bolt head support surfaces.

Regards,
Philippe Gachet
Senior technical consultant
Philippe.gachet@skf.com



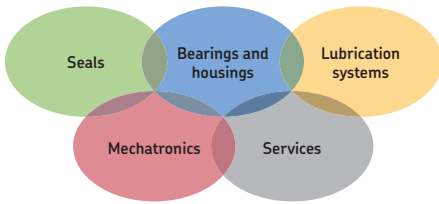

The Power of Knowledge Engineering

Combining products, people, and application-specific knowledge, SKF delivers innovative solutions to equipment manufacturers and production facilities in every major industry worldwide. Having expertise in multiple competence areas supports SKF Life Cycle Management, a proven approach to improving equipment reliability, optimizing operational and energy efficiency and reducing total cost of ownership.

These competence areas include bearings and units, seals, lubrication systems, mechatronics, and a wide range of services, from 3-D computer modelling to cloud-based condition monitoring and asset management services.

SKF's global footprint provides SKF customers with uniform quality standards and worldwide product availability. Our local presence provides direct access to the experience, knowledge and ingenuity of SKF people.

SKF Global Pulp & Paper Segment

Contact/Responsible editor
philippe.gachet@skf.com

© SKF is a registered trademarks of the SKF Group.

© SKF Group 2014

The contents of this publication are the copyright of the publisher and may not be reproduced (even extracts) unless prior written permission is granted. Every care has been taken to ensure the accuracy of the information contained in this publication but no liability can be accepted for any loss or damage whether direct, indirect or consequential arising out of the use of the information contained herein.

PUB 72/S9 11147/10 EN · May 2014





Don't judge too quickly

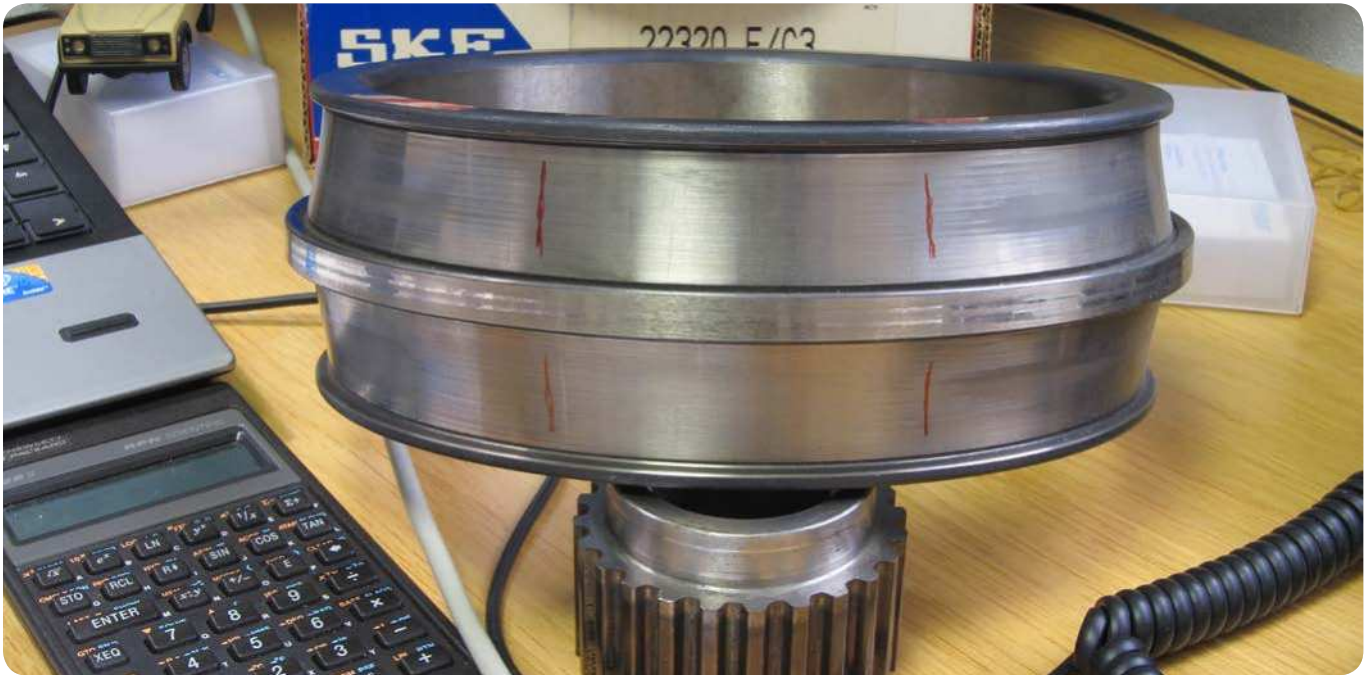

The inner ring of the bearing used to check shaft geometry on the cover photograph of SKF Pulp & Paper Practices 11. You can tell it's not an SKF bearing because it has a central flange. SKF spherical roller bearings have floating guide rings.

You may recall the cover photograph on the previous issue of SKF Pulp & Paper Practices which showed a former colleague of mine checking journal geometry with Prussian blue and a spherical roller bearing inner ring. A number of readers contacted me to say that this was not a precise enough method. In reality, the photograph did not show the complete picture. The load zone on the inner ring raceway wasn't constant. This isn't normal for a bearing inner ring mounted on a drying cylinder journal. Was it an inner ring quality issue? A shaft quality problem? Something else entirely? I'll show you how we determined the real problem using Prussian blue in the next issue.

Coming back to this issue of SKF Pulp & Paper Practices, we're going to examine paper machine speed increases from a bearing perspective. SKF engineers often get asked questions about this as many

mills need to run their machines at more than their original design speeds. As such, I'll set out some guidelines for what to look at and how to work with a bearing manufacturer on a machine speed increase project in the rest of this issue.

Regards,
Philippe Gachet
Senior technical consultant
SKF Pulp & Paper global segment



Paper machine speed increases

Paper machines, as you know, are created with specific design speeds in mind and these have increased significantly over the years. In 1964 when we published the first SKF Rolling bearings in paper machines handbook, most machines were running below 500 m/min. A few tissue machines and newsprint machines were designed for 900 m/min or more, but no machines had broken the 1 000 m/min barrier. Today, 50 years later, speeds have doubled with some machines designed to operate at over 2 000 m/min and older machines often need to run at well above their original design speeds.

Several times a year I'm asked to give advice on machine speed increases. These days, it's mainly helping SKF colleagues handle requests from their paper mill customers. In the past, it wasn't unusual to be shown an old paper machine and asked whether it could run at higher speeds. On one memorable occasion, I was given the machine speed and a list of bearings (without the roll diameter dimensions) and asked to comment on the machine speed increase within a week.

After nearly a quarter of a century of working with application engineering for the paper industry, I've come to the conclusion that:

- People tend to focus on the bearing rotational speed only. They seem to have potential problems with additional centrifugal forces creating more mechanical stress on the bearing components in mind. They ask questions like "Can this solid press roll bearing that's now running at 250 r/min cope with 280 r/min?"
- There are so many different paper machines with different configurations and different upgrades that it isn't possible to give meaningful advice on speed increases without some work. The operating conditions of each bearing need to be checked. A study, in three phases, needs to be undertaken:
 - 1 Technical information is gathered and the amount of engineering man hours is estimated.
 - 2 Answers are found on whether the machine can be speeded up without modification or not. The amount of time needed for this phase can vary enormously. Some machines might take as little as eight hours. Others can need more than 300 man hours.
 - 3 A detailed study on the modifications needed to bearing housings, lubrication systems etc. is undertaken.

I'll provide more details and explanations about all this in the rest of the newsletter.

1. Bearing operating condition changes due to machine speed increases

When paper machine speed is increased other things change too. Wire and felt tension, for instance, are also increased. In extreme cases, especially in the forming section, the tension increases so much that the rolls bend and roll failure by fatigue fracture can occur. Note, however, that increasing wire and felt tension does not always increase the loads on the bearings. It can also decrease the load (→ figure 1)

This can also happen with press rolls (→ figure 2). With increasing speed, the paper spends less time in the nip and the easiest way to maintain dewatering without changing the press is to increase the nip load. The nip load will be in the opposite direction to the top roll

(roll C) weight so increasing nip load will reduce the load on the bearings supporting the top roll if its weight is larger than the nip load.

There can be an issue with suction rolls too. As with the press rolls, dwell time is reduced so suction is often increased to remove the same amount of water. Increased suction also affects the suction roll cylinder of course and the position of the suction box will dictate whether the load on the supporting bearings increases or decreases (→ figure 3). In the case of suction press rolls, both nip load and suction have to be taken into account.

Increasing machine speed also means that the paper is in the dryer section for a shorter time. Rather than extending the section by adding more drying cylinders, mills often simply increase steam temperature. This can lead to problems.

Fig. 1 Higher felt tension increases the loads on roll A bearings, but can decrease the loads on roll B bearings.

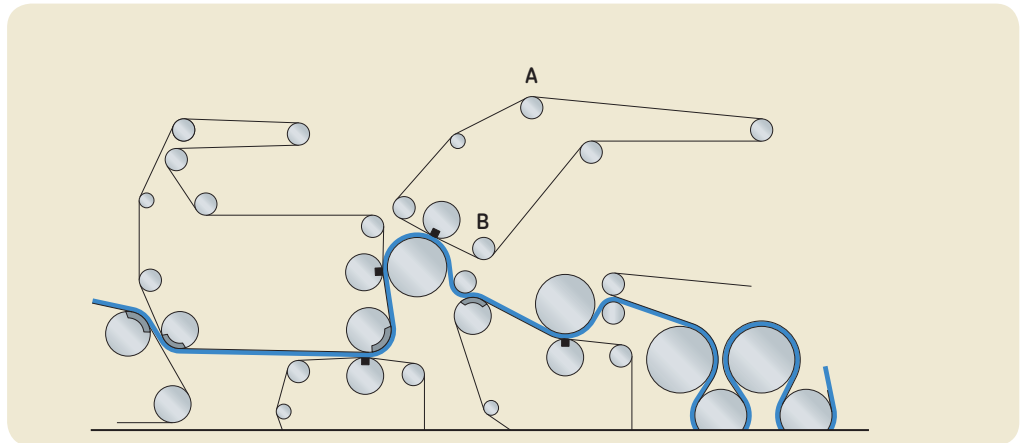

Fig. 2 If roll C's weight is larger than the nip load, increasing the nip load will reduce the load on the bearings.

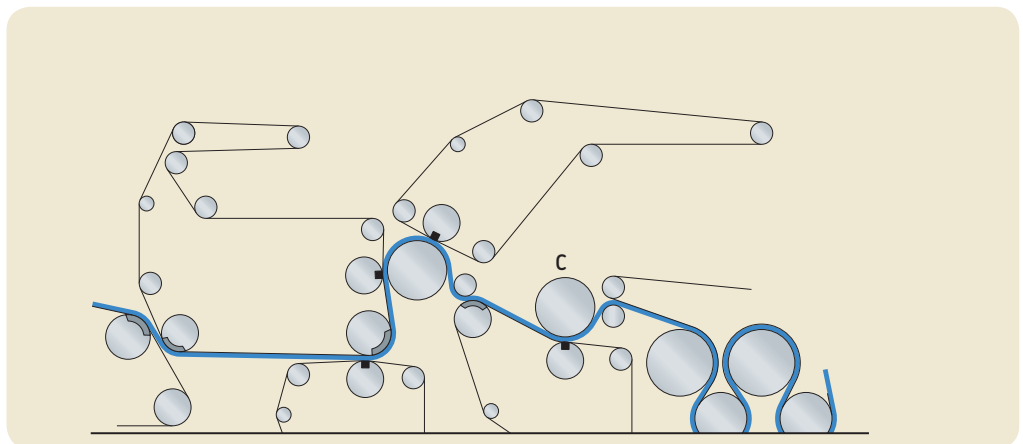
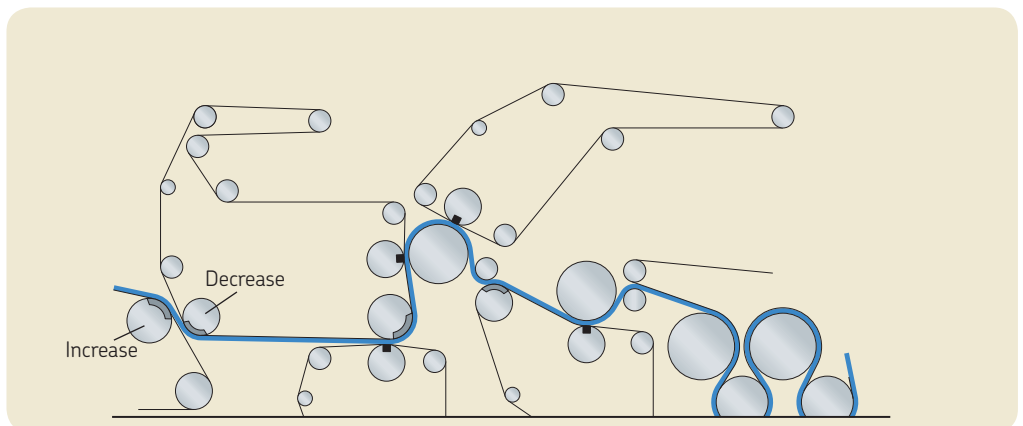

Fig. 3 The load on the suction roll bearings can either increase or decrease depending on the position of the suction box.



I remember a case with an old Beloit kraft machine. It had uninsulated dryer cylinder journals, C3 clearance class bearings and must have been designed for steam temperatures no higher than 130 °C. The mill asked me if they could keep the same oil flow if the steam temperature was increased to 170 °C following a speed increase project. I told them that they could do this if they insulated the journals and mounted C4 clearance class bearings. It simply wasn't possible to meet SKF lubrication recommendations (see *SKF Pulp & Paper Practices 7*) without journal insulation. Not even by upgrading the oil from ISO VG 220 to ISO VG 460 and increasing the oil flow. Besides which, the mill was unable to increase flow without changing the circulating oil system and the design of the bearing housings used. Eventually, after much discussion, the maintenance manager convinced his colleagues to add a second hand dryer section from another mill. More often, mills just increase steam temperature and dryer cylinder bearing life decreases.

Paper machine cylinders and rolls are generally balanced for maximum speed as designed. Speeding them up beyond their original design speed can lead to vibrations so they should be rebalanced for the increased speed. If this is not done, there can be issues especially in dryer sections with bearing housings mounted on rockers (see *SKF Pulp & Paper Practices 7*). The problem is that front side bearing housings on rockers do not damp vibrations (→ **figure 4**). Usually, the first problem that is noticed will be increased rocker wear. Reworking the housing to a fixed housing (→ **figure 5**) and substituting a CARB toroidal roller bearing can be enough to solve the problem, but we recommend balancing the cylinders anyway.



Fig. 4 A rocker housing on an old paper machine.



Fig. 5 The housing base is machined to remove the rockers and to accept customized feet. The oil inlet and outlet are also modified.

2. Bearing speed limits (for spherical roller bearings and CARB toroidal roller bearings without seals)

The questions that are normally asked relate to what speeds bearings can operate at and whether the existing bearings can tolerate increased machine speeds. Some people would just open a catalogue and conclude that bearings can operate up to the indicated limiting speed. This is wrong.

Limiting speed isn't the maximum speed limit. Consider the example of a 232/500 CAK/C084W33 press roll bearing. It has a 500 mm bore, it weighs nearly a ton and it has a limiting speed of 500 r/min. However, such bearings have run on our test rigs at 960 r/min and could have run even faster.

Some installed bearings on modern deflection compensating press rolls run close to or above the limiting speed as the outer ring rotates. In such cases, the roller sets run faster than they would do if the inner ring was rotating.

Limiting speeds consider cage strength, smearing risk, vibration and field experience. The limiting speed values in product tables are practical recommendations for general applications and they are rather conservative to give a safety margin.

If you are going to run your bearings close to or above the limiting speed, I recommend a direct seat on the shaft, narrower run-out tolerances and circulating oil lubrication. Don't try it with bearings on adapter sleeves or with grease lubrication.

What then is the real operating speed limit? This depends, in fact, on how the heat created by internal bearing friction can be dissipated and the overall run-out values of the bearing and surrounding components e.g. housing, shaft, sleeve etc.

At first glance, the equations seem easy:

- Power loss (W) = $0,105 \times$ total internal bearing friction (Nm) \times rotational speed (r/min)
- Bearing temperature increase (°C) = Power loss (W) / Cooling factor (W/°C)

The difficult part is calculating the cooling factor. This depends on housing, shaft, foundation geometry and material, the ambient air temperature and the lubrication method.

The SKF rolling bearing catalogue will help you to determine whether you're on the safe side or not.

There is another speed indicated in the bearing catalogue – the reference speed. This is a thermal speed limit where equilibrium is reached between heat created by a bearing and heat dissipated under certain conditions of temperature, load and lubrication (see *norm ISO 15312:2003*) e.g. bearing temperature increase of 50 °C above 20 °C ambient temperature. The reference speed and limiting can be quite different e.g. a 231/750 spherical roller bearing, weigh-

ing 1,7 tons, has a limiting speed of 430 r/min and a reference speed of 220 r/min.

Real bearing operating conditions, of course, do not always correspond to the ISO norm so there are adjustment factors for load and lubricant viscosity. The reference speed multiplied by the adjustment factors gives an adjusted reference speed. This is quite important as it gives an SKF engineer an indication that, without undertaking cooling factor calculations, below this speed there is enough cooling to dissipate heat without the need for circulating oil or other cooling systems. Of course, if he needs to do a bearing temperature calculation, he would need to calculate the cooling factors.

The aforementioned 231/750 mounted in a press roll, lubricated with an ISO VG 150 oil with a 2,8 MN radial load would have an adjusted reference speed of 66 r/min during start up (when the oil and bearing were still cold) and 94 r/min during steady state operating conditions.

Is the adjusted reference speed a limit? No, it's not. In the real application the bearing rotates at 280 r/min. This is possible because a circulating oil lubrication system dissipates the heat created by the bearing. If there was oil bath lubrication instead, it would be very risky to run at twice or more the adjusted reference speed as the bearing would create more heat than could be removed. You can find more information on this on **pages 118–128** of the *SKF Rolling bearings catalogue* (publication number 10 000).

If the application is grease lubricated, speed factor A should be calculated. This gives an idea of the peripheral speed of the rollers. For applications with inner ring rotation, use the equation below.

$$A = n \times \frac{d+D}{2}$$

For applications with outer ring rotation, such as old grease-lubricated suction rolls, use the equation below as a rough estimate. For a more precise calculation, internal bearing geometry information such as contact angle and roller diameter would be needed.

$$A = n \times D$$

n: rotational speed in r/min

d: bearing bore diameter in mm

D: bearing outside diameter in mm

Compare this with values given in **table 5** on **page 257** of the *SKF Rolling bearings catalogue*. It gives recommended limits for the A factor with grease lubrication. These are not absolute limits, but my experience leads me to strongly recommend that you follow them. With manual relubrication it's far too easy to over-grease and end up with overheating.

Starting to get a headache? Let's make it simple with a drawing (→ figure 6).

Very low speed isn't an easy situation since bearings don't rotate fast enough to build up an oil film between the rollers and raceways. In such cases, high viscosity oils are needed with anti-wear or EP additives. Note that this situation might occur at higher speeds too if operating temperature is too high and lubricant viscosity is too low. This is sometimes seen on heated cylinders with uninsulated journals.

With grease lubrication and very low speeds, bearings may not heat up to a sufficient temperature that the lubricant bleeds enough oil. Be careful when lubricating felt rolls at the bottom of the dryer section with high temperature grease as there may not be enough oil bleeding with the operating temperatures there.

Speeds below the adjusted reference speed are quite easy for application engineers as the indications given in the *SKF Rolling bearings catalogue* can often be used. I remember being asked by a customer whether his felt roll bearings could still be lubricated with grease after a speed increase project as he was reluctant to spend more money on converting to an oil lubrication system. After finding out the grease he was using and the load on the bearings, the manual calculation using the catalogue took less than five minutes. It turned out that the increased speed would still be under the adjusted refer-

ence speed and the A factor was below the recommended limit. As such, I told him he could stick with grease lubrication, but that we'd need to look at the minimum load. I'll explain why later on.

Above the adjusted reference speed things start to become complicated. You need to think carefully about heat exchange. If the bearing is manually relubricated with grease and if the speed is above the adjusted reference speed, a centralized grease system or circulating oil system might be necessary. Above a certain speed, oil lubrication is the only option. In addition, the bearing clearance class might need to be increased. As the *SKF Rolling bearings catalogue* does not contain all the information needed to make this decision, you need to get an SKF engineer with access to specialist software to advise you.

Near the reference speed and above, you not only have to consider clearance class, lubrication and heat evacuation, you also need to look at run-out tolerances of the bearings and other rotating components e.g. the shaft or cylinder. The bearings should be mounted directly on cylindrical or tapered seats rather than on adapter or withdrawal sleeves. The bearing seat should be manufactured with tighter tolerances as well. For circularity and straightness reasons, two IT grades better than the specified dimensional tolerances are recommended. Bearings with reduced run-out tolerances should be mounted. Even though standard SKF bearings have lower

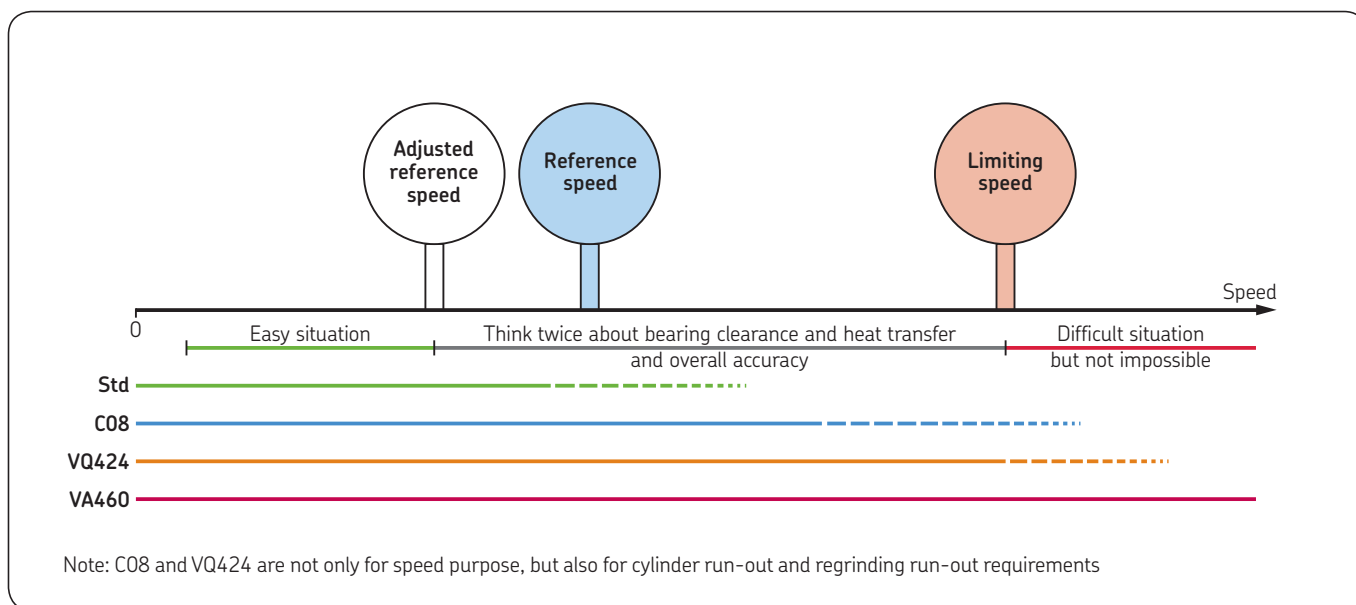

Fig. 6 Recommended bearing variants by speed.



Fig. 7 A roll grinding machine with the roll rotating on its main bearings.

run-out than ISO Normal, I often recommend bearings with a C08, a VQ424 or a VA460 suffix (→ **table 1**). My recommendation is based on the specific application and speed, so sometimes I will suggest standard SKF bearings. Note that for grease-lubricated bearings mounted on withdrawal or adapter sleeves, it can be necessary to change to an oil-lubricated bearing with a special suffix mounted on a new direct tapered seat.

At the limiting speed, because bearings will not run in laboratory conditions, I recommend VQ424 or VA460 bearings and contacting a local SKF application engineer.

In conclusion, the operating speed limit doesn't depend on the mechanical stress due to centrifugal forces, but mainly on how the heat created by internal friction is dissipated. That said, the internal bearing clearance class and run-out tolerances are also important.

Table 1

C08, VQ424 and VA460 bearings

- A C08 suffix denotes a P5 run-out tolerance class. The circular radial run-out is one quarter of the ISO Normal class. Remember that all SKF standard bearings with inner ring bore diameters below 320 mm have P5 run-out even if they do not have a C08 suffix.
- VQ424 has, in addition to the C08 features, special tolerances on ring wall thickness. The ISO Norm covers the allowed maximum running accuracy deviation whereas VQ424 also looks at the level of deviation. It was developed for Valmet in the beginning of the 1990s for faster and more accurate regrinding of rolls supported by the bearings (→ **figure 7**).
- VA460 is essentially a VQ424 bearing modified to withstand the effects of centrifugal forces due to very high speeds.

3. Other issues related to higher speed

There are other important things to consider when machine speed is increased. Let's imagine for now that operating conditions, such as the loads on the bearings, don't change.

The higher the speed, the higher the difference between inner and outer ring temperature and the higher the roller temperature. The inner ring is generally hotter than the outer ring. So, higher speed means increased clearance reduction. Above the adjusted reference speed, a higher clearance class is needed (see **page 5** of *SKF Pulp & Paper Practices 2*). When approaching the limiting speed, an additional increase in clearance class might be needed. Furthermore, the relationship between the clearance of an unmounted bearing and the bearing size is not linear. As such, for very large bearings - such as the ones found in press rolls on modern high speed machines - a higher clearance class than would be selected for a medium size bearing might be necessary.

To roll without skidding or sliding, a roller needs to be squeezed between the inner ring and the outer ring. The roller has a certain mass and thus a certain rotational speed dependent inertia that makes it reluctant to accelerate. When exiting the loaded zone of the bearing the roller slows down since there is friction against the cage and in the lubricant in the unloaded zone. When it enters the loaded zone again it is squeezed between the rings and forced to accelerate. If there is a large difference between the speed on the rollers in the unloaded and loaded zones and if there is insufficient load in the loaded zone, it will accelerate more slowly than required and create smearing marks in the entrance to the loaded zone (→ **figures 8 and 9**).

The other case is when the load zone has very light roller loads or when the load zone isn't well defined due to the roll or cylinder weight being supported by the nip load rather than the bearings. This happens in some deflection compensating press rolls as the radial load is carried by both the hydrostatic shoe bearings and the roller bearings. Depending on the oil pressure in the hydrostatic

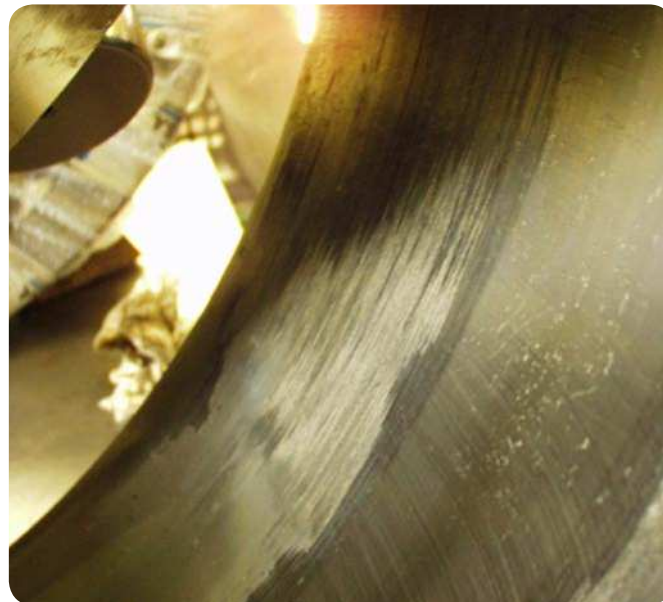

Fig. 9 Smearing marks on the entrance to the load zone of a solid press roll bearing.

shoe bearings, roller bearings could face an undefined load situation with the possibility of zero load. As the load is low there is a risk that that rollers are not always forced to roll at an adequate speed. Rollers slide, accelerate and decelerate in the insufficiently loaded load zone or in the undefined load zone (→ **figures 8 and 10**). Note that this can also be an issue for bearings in some suction rolls, press rolls, calendar and – more rarely – wire and felt rolls.

Increasing machine speed also increases bearing speed and roller inertia leading to a higher risk of smearing due to low load issues.

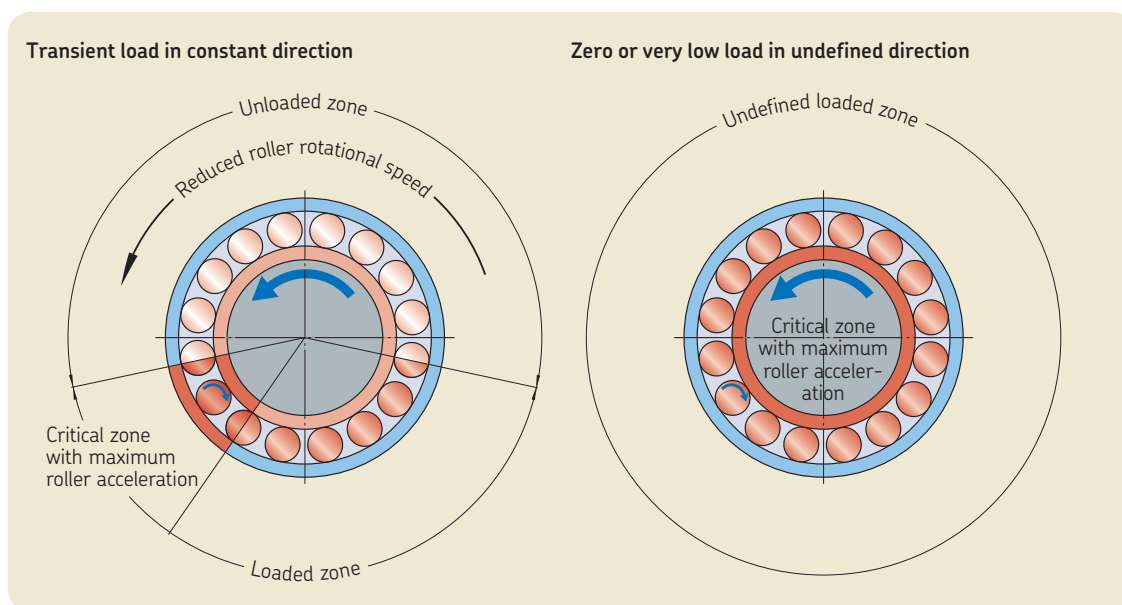

Fig. 8 Roller slip and the risk of smearing.

For each speed there is a minimum load that needs to be applied to the bearing. Increasing machine speed without changing the load can lead to premature failure if it was already close to the minimum required for the original speed.

In addition, increasing machine speed might also make it run at one of its natural frequencies. High vibration amplitude may occur. I have never seen paper machines breaking, but I have seen rocker housings falling off the rockers, rockers having premature wear, facets on cylinders or rolls and increased rejected paper. But in other applications, in other industries, I have seen premature bearing failures because grease got softer with the vibration and concrete supporting the machine fractured.

Note that in one case, after a paper machine upgrade, without machine speed increase, the new NIP load in conjunction with the change of a roll diameter made the press roll operate close to its natural frequency. I was contacted since the customer thought that the root cause was the roller bearings.

4. The influence of load change on bearings

As mentioned in section one, machine speed increases also lead to load changes. Loads can increase or decrease on rolls depending on their position in the machine.

When the load is reduced there can be the risk of low load issues as explained in section three. These can often be resolved using NoWear coated bearings to avoid smearing or by reducing the number of rollers so that contact pressure per roller is increased.

When the load increases there are several things to consider.

A 10% load increase reduces calculated basic rating life L10h by 30%. If the speed increases too, the basic rating life is further reduced. Thankfully, bearing basic dynamic load ratings have increased over the years. A machine designed in the early 1970s can substitute the original SKF 22314 CK/W33 felt roll bearings with today's SKF 22314 EK ones and increase loading by 57% without reducing the basic rating life. This explains why there aren't more fatigue failures despite wire and felt roll tensions increasing significantly over the years. In some unusual cases, rolls designed many years ago break due to fatigue before experiencing severe fatigue issues with the bearings.

Despite the increases in bearing basic load ratings, you still need a tighter fit if you increase the load. High pressures between rollers and raceways create ring deformation and there can be micro movement between a ring and its seat. This creates fretting corrosion and can also lead to creeping and wear if the ring starts to rotate on its seat.

Figure 11 shows a dryer section felt roll bearing mounted on an adapter sleeve. The mill had replaced the gear with silent drive so the drying cylinders were driven by some of the felt rolls via the felt. Felt tension had been increased and bearing service life dropped dramatically. It was discovered that the bearings were working loose on their seats and rotating together with their adapter sleeves creating heavy wear. This can lead to catastrophic failures (→ **figure 12**). Another problem can be shaft rotating deformation which creates alternate stress and flexion close to the bearing seat. Increasing the bearing drive-up to more than the general recommendation and using the SKF Drive-up method rather than the feeler gauge method increased the bearing service life.

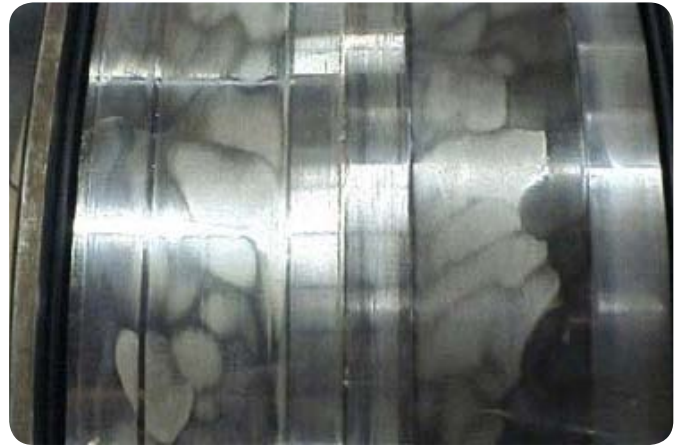

Fig. 10 Damage on the inner ring of a suction roll bearing due to undefined load zone after a speed increase and/or a suction vacuum increase.



Fig. 11 Fretting corrosion in the bore of an adapter sleeve of a dryer section felt roll bearing due to an insufficiently tight fit relative to the load.

If loads on bearings are to be increased, fits and mounting procedures should be reviewed. Be aware that tighter fits are used it might be necessary to use a bearing with a higher internal clearance class.

If the load is increased and the speed isn't, bearing operating temperature will still rise. The temperature difference between bearing inner ring and outer ring will also increase. In such cases, a higher internal radial clearance may be needed.

Increasing the load can deform the bearing housing, the machine frame and the shaft or roll. This can have either a positive or a negative effect depending on how the deformation changes the load distribution in the bearings. Normally, wire and felt roll housings are rigid enough relative to the loads they experience, but this is not the case for some press roll bearing housings. For them, FEM calculations can be worthwhile during a machine speed increase project (→ **figure 13**).

5. The three phases of a study

Based on my experience and to avoid the steps that are often forgotten during a machine speed increase, I always recommend a three phase study: pre-study, analysis, execution.

The phase one pre-study is to ascertain how difficult it will be. Will it require advanced calculations or just catalogue ones, for instance. Some quick and basic calculations will certainly be needed in this phase and an estimate of the man hours needed for phase two will be made.



Fig. 12 Advanced wear with rotation of the adapter sleeve on the shaft of a dryer section felt roll bearing. The related high temperature reduced the bearing clearance resulting in uncontrolled preload and, finally, seizure.

At a minimum, the SKF application engineer will need the following information from his customer:

- A drawing of the bearing assembly including the housing and shaft. Note that a detailed drawing of the housing and shaft are recommended and may be needed for some calculations.
- A drawing of the complete roll or cylinder.
- Minimum and maximum existing and future load for all positions. The direction and position of loads should be marked on drawings.
- Existing and future bearing rotational rather than machine speed for all positions.
- Minimum and maximum ambient temperature for all positions.
- Existing and future heating fluid temperature for drying cylinders, Yankees and calendars together with information on the existing lubricant, lubrication system, relubrication interval, oil flows etc.
- The history of bearing replacement and any repetitive bearing failures for at least the last five years.

Collecting the above technical information, especially the loads, is what takes the most time. Several weeks or even months may be needed to do it properly. Often, due to missing information, the SKF application engineer has to make assumptions about the operating conditions. These should always be discussed and agreed with the customer.

At the end of the pre-study, an estimate of the man hours needed for phase two is made. No technical recommendations are made as agreement is needed from the customer to undertake the analysis necessary to make meaningful ones.

Assuming that there is agreement with the customer to proceed, the SKF engineer will undertake further calculations and analysis in phase two. During this phase, any modifications necessary to bearings, housings, mounting and/or lubrication procedures etc. will be uncovered. In some cases, no modifications are necessary.

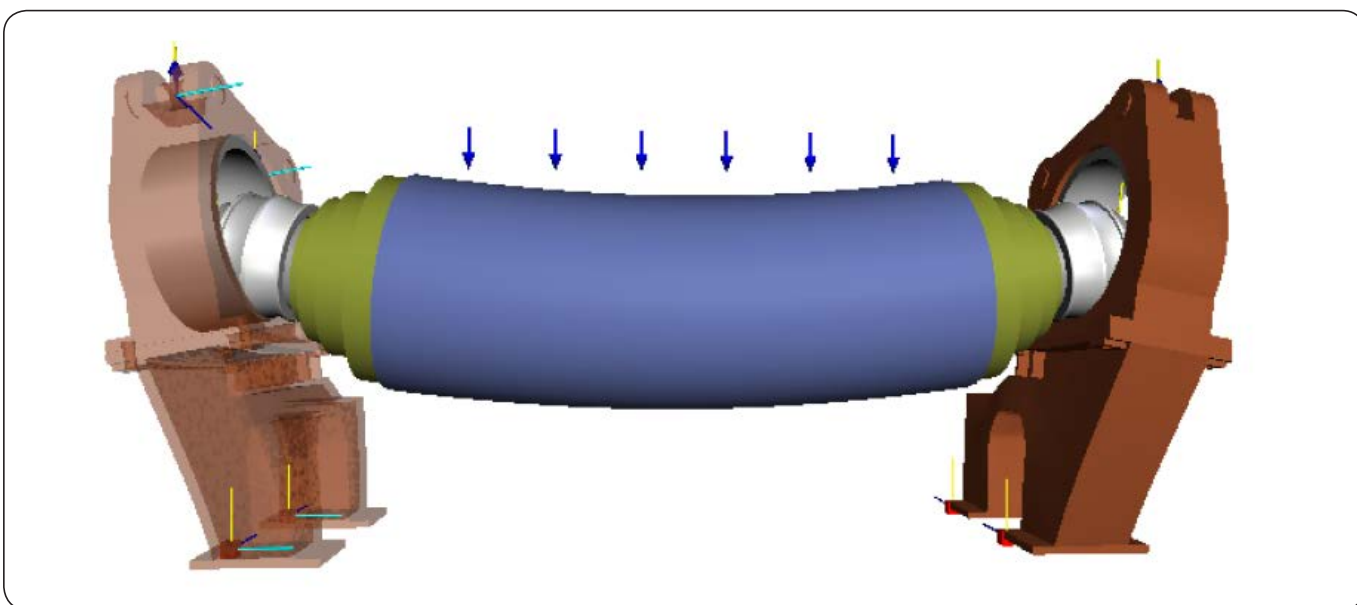

Fig. 13 SKF FEM calculations showing the deformation of the solid roll in a shoe press under working load. Note that a high magnification has been applied to clearly visualize the deformations.

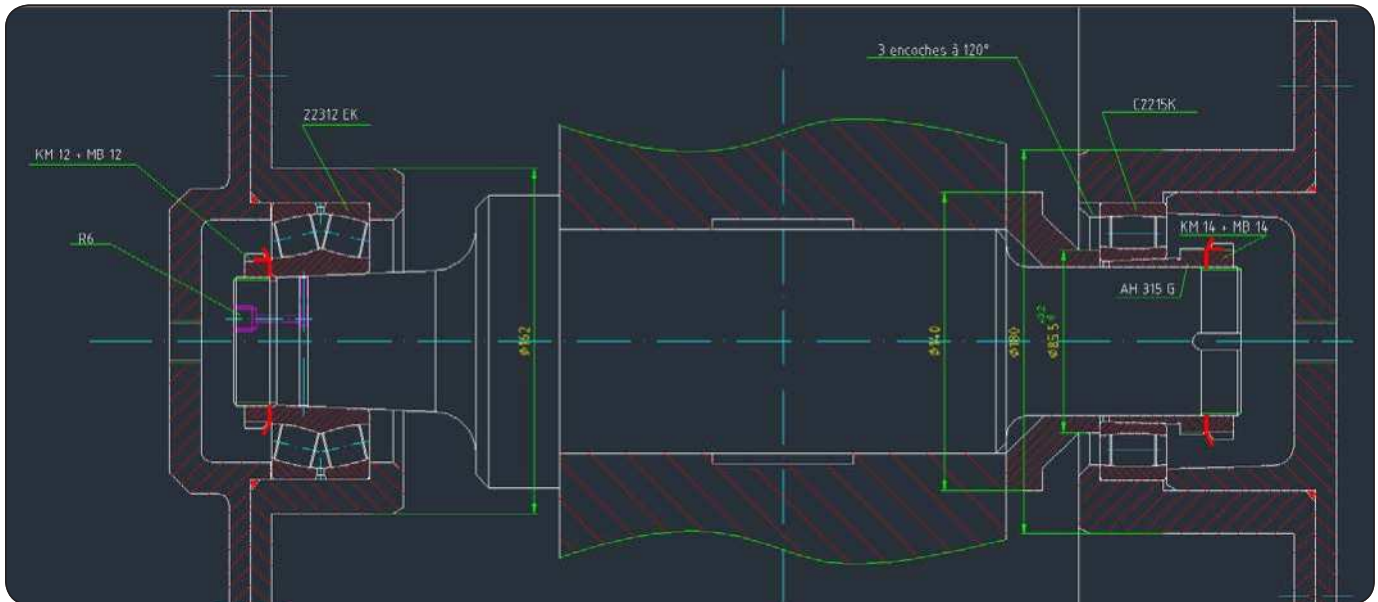

Fig. 14 Modified intermediate gear bearing arrangement with a spherical roller bearing and a CARB toroidal roller bearing. Both have tight fits on their inner and outer rings. The original design had two spherical roller bearings with loose fits on the outer rings. As the gear was driven or driving, there were load direction changes on the outer rings. This led to wear due to micro displacement and creeping of outer rings in their seats.

At the end of phase two, the customer will receive technical information and recommendations on whether FEM calculations, special housing design work and/or new lubrication systems are needed. For example, the SKF engineer could:

- 1 Advise that CARB toroidal roller bearings rather than spherical roller bearings should be used on the non-locating drying cylinders
- 2 Specify the recommend bearing designation and SKF bearing rating life
- 3 Outline the require oil viscosity and oil flow plus the journal insulation requirements
- 4 Propose that the existing housing should be modified to accept CARB or that a new housing should be used
- 5 Indicate any consequences if some recommendations were not adopted e.g. keeping an old oil circulation system with limited oil flow and poor filtration
- 6 Recommend new mounting procedure and/or new fits (if required)

Note that any housing, journal insulation or circulating oil lubrication system design work needed would be undertaken in phase three.

The results of the analysis phase are presented to the customer. Quite often this leads to various “what if?” questions. This is quite normal since he needs to understand and balance the benefits of the proposal against the necessary investment. The phase ends with a decision from the customer on whether to proceed with phase three.

In phase three, the execution phase, any modification design work is undertaken. This can include such things as special housings,

designing in new lubrication systems and modifying existing bearing assemblies (→ **figure 14**). It also included any modifications needed on site. All this work can be undertaken by SKF, the customer themselves, an equipment manufacturer, a sub-contractor or the work can be shared between these various parties.

To sum up, a machine speed increase project is not that simple from a rolling bearing point of view. It isn't just about whether a bearing can tolerate the increased speed. I hope that this issue of SKF Pulp & Paper Practices will help people know what to consider and how to work with SKF on such projects.

As a final note, please remember that the real speed limit for spherical roller bearings and CARB toroidal roller bearings is reached when the heat generated by internal friction cannot be dissipated. In my experience, the mechanical limits due to stresses on the bearing components from centrifugal forces are never reached on SKF bearings in paper machine applications if the arrangement is well engineered.

Regards,
Philippe Gachet
Senior technical consultant
Philippe.gachet@skf.com



The Power of Knowledge Engineering

Combining products, people, and application-specific knowledge, SKF delivers innovative solutions to equipment manufacturers and production facilities in every major industry worldwide. Having expertise in multiple competence areas supports SKF Life Cycle Management, a proven approach to improving equipment reliability, optimizing operational and energy efficiency and reducing total cost of ownership.

These competence areas include bearings and units, seals, lubrication systems, mechatronics, and a wide range of services, from 3-D computer modelling to cloud-based condition monitoring and asset management services.

SKF's global footprint provides SKF customers with uniform quality standards and worldwide product availability. Our local presence provides direct access to the experience, knowledge and ingenuity of SKF people.

SKF Global Pulp & Paper
Segment

Contact/Responsible editor
philippe.gachet@skf.com

© SKF is a registered trademarks of the SKF Group.

© SKF Group 2014

The contents of this publication are the copyright of the publisher and may not be reproduced (even extracts) unless prior written permission is granted. Every care has been taken to ensure the accuracy of the information contained in this publication but no liability can be accepted for any loss or damage whether direct, indirect or consequential arising out of the use of the information contained herein.

PUB 72/S9 11147/11 EN · September 2014





We don't talk about microns in a mill workshop

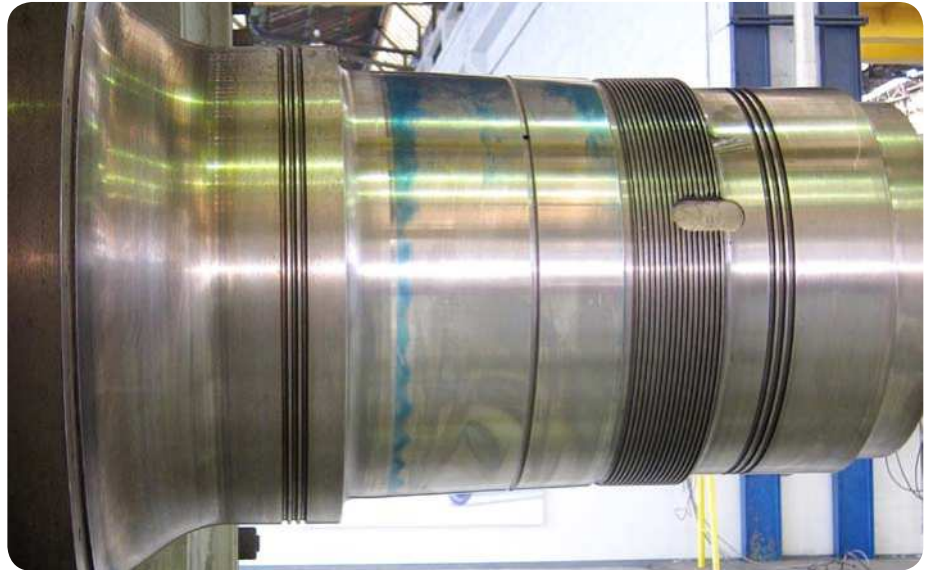

Faulty Prussian blue test due to too low axial force on the bearing

As a teenager, I used such cheap measuring tools that I was never really sure whether the crankshaft bearing seats on my motorbikes were within tolerances or not. I remember using Prussian blue to check the flatness of cylinder heads and engine blocks and thinking that industry must be another world. A world with access to high precision measuring tools in which measurement uncertainty would be very small compared to manufacturing tolerances. One in which I would never use Prussian blue again except, perhaps, for gears.

The reality, I learnt, was quite different. I've seen chisels rather than impact spanners used to tighten lock nuts, hot oil and even flame used instead of induction heaters, twisted feeler gauges used instead of hydraulic nuts and dial gauges to mount tapered bore bearings and so on. I found that using inadequate tools has a cost in terms of reduced bearing lives, damaged bearing seats, increased maintenance man hours, lost production etc. It continues to surprise me that many companies simply accept these costs.

Maintenance teams, of course, do not always have access to all the measuring tools they need. Even if they do, they're not always calibrated properly. The situation is such that I've stopped counting the number of times that I've had to check a bearing seat diameter with a micrometer without a calibration standard nearby. Even if

the right tools are available and they're properly calibrated, it's not unusual for measurements to be skipped due to pressure to get machines up and running as quickly as possible.

To further complicate things, we also need to consider the individual. Two mechanics will often find different clearance values when measuring spherical roller bearings with feeler gauges, for example. While we're used to talking about microns in the bearing world, you don't often hear them mentioned in workshops. Instead, decisions are often based on feeling. The feeling of a new mechanic tends to be based on that of the experienced mechanic that trained them. But how do you calibrate the feeling of the experienced mechanic?

So, imagine the uncertainty when measuring a distance over a taper gauge to check the bearing seat for a press roll bearing. You don't have a taper gauge? Do you have Prussian blue instead?

Regards,
Philippe Gachet
Senior technical consultant
SKF Pulp & Paper global segment



Checking tapered journal geometry

Most questions about the condition of tapered bearing seats relate to surface issues like dents, fretting corrosion, corrosion, wear due to the bearing rotating on its seat and smearing marks. The issue of geometrical form is often forgotten as many suppose that this doesn't change. In fact, surface damage can modify seat geometry (→ figure 1) and journals can be out of tolerance when new.

I have seen a number of bearing failures due to out of tolerance tapered seats changing the load distribution and the fit. As such, I recommend that seats – new or old – are checked before mounting bearings. An exception can be considered when a journal has been in operation and doesn't show uneven contact marks and the dis-mounted bearing does not have strange contact marks or load distribution.

While there are several ways to check a tapered seat, I will not examine modern methods such as laser measurements or computer aided metrology in this issue of *SKF Pulp & Paper Practices*. Instead, I will focus on Prussian blue and other good, old, reliable methods using tools that don't run out of battery power and which still work even when submerged in oil.

Before going into detail about these old reliable methods, here are my recommendations for pre-check preparations:

- 1 Remove any fine rust particles and oxidised oil or grease with a heavy duty scrub sponge. Petroleum-based solvents such as white spirit can help with this.
- 2 Remove any bumps – smearing marks, raised metal at dent edges etc. – with a flat file. No bumps should be felt when you pass your hand over the journal surface, but small dents are acceptable.
- 3 Clean the journal surface with a petroleum-based solvent such as white spirit and a clean rag.

1. The Prussian blue method

Prussian blue, as you know, is a dark blue pigment which can be mixed with oil to check the contact between two metal surfaces. The resulting mixture is known as engineer's blue or machinist's blue.

The way the Prussian blue method is supposed to work is that a gauge ring, with checked and calibrated bore geometry, has its bore blued – i.e. a thin layer of Prussian blue is applied to the entire bore surface – and then the gauge ring is placed on the tapered journal and firmly pushed axially. Some engineers would say that the ring is slammed against the journal to ensure intimate contact. When the gauge ring is removed, the parts of the journal where there was good contact with the ring will be blue.



Fig. 1 *Fretting corrosion and smearing on a press roll journal, but why is it only on the left hand side?*

As a simple rule:

- For new journals, a minimum of 90% of the contact surface should be blue.
- For old journals, a minimum of 80% of the contact surface should be blue.

In practice, gauge rings are often not available for all journal dimensions, especially large ones. In such cases, an option is to use a new bearing that will subsequently be mounted. A significant advantage of doing this is that the contact between the two elements that will be in contact during operation is checked.

A drawback is that a new bearing, which needs to be unpacked, is required. That said, unpacking should not be an issue if journal checking is done just before mounting the bearing. Another drawback is that if the contact is below the previously mentioned 80% or 90% target, it can be difficult to tell whether the journal or the bearing are out of tolerances or whether both are within tolerances, but the geometrical forms are not close enough for Prussian blue transfer.

It's worth noting that bearing bores are manufactured with larger tolerances than calibrated rings gauges and large bearings deform under their own weight. Also that the maximum bearing bore taper angle is larger than that of the journal and the minimum taper angle on the journal is smaller than that of the bearing. Consequently, it's not unusual for a new bearing and journal to achieve less than 80% contact, with little or no circumferential contact in the upper part of the taper, even if both are within tolerances.

Deviations other than taper deviations revealed using Prussian blue are most likely to be the result of one of the components being



Fig. 2 Checking the contact between bearing and journal with Prussian blue. Note that the hammer is for gently knocking the inner ring to ensure intimate contact.



Fig. 3 The inner ring of a drying cylinder bearing with no load zone between the red lines.

out of tolerances. The question is which one. To get a clue simply mark the position of the inner ring relative to the journal, dismount the bearing, clean the journal, put a new coat of Prussian blue in the bearing bore and rotate the bearing so that the inner ring doesn't seat in the same position. If the contact pattern is the same on the journal, it's a journal issue. If the contact is still in the same position in the bearing bore, it's a bearing issue.

Let's look at the example from the cover of *SKF Pulp & Paper Practices 11*. It showed my colleague checking the tapered seat of a drying cylinder with the inner ring of a dismantled bearing (→ **figure 2**). The load zone on the inner ring raceway wasn't normal as there was no load zone on part of it. This is unusual for a ring that rotates relative to the load direction (→ **figure 3**).

We found that part of the journal was not in contact with the inner ring and that the width of this closely matched the surface distress on the bearing's raceway.

So, was it a journal or an inner ring bore issue? After rotating the bearing inner ring relative to the journal and repeating the Prussian blue process, the pattern on the journal was the same. This suggests a journal form issue in this particular case (→ **figure 4**).

With heavy bearings supported by a strap from a crane, it is difficult to move the bearing coaxially to the journal and slam it. In such cases, it is usually impossible to achieve intimate contact. This is because a bearing displaced from its equilibrium position under a crane will move upwards following a curve that is a chord of a circle. This is also a problem when mounting heavy bearings on cylindrical seats as the bearing has to be pushed quickly into its final position before it cools down and creates a tight fit. To make things easier, a spring can be mounted between the strap and crane hook (→ **figure 5**).

Fig. 4 The absence of Prussian blue indicates no contact between the ring and the journal.



Fig. 5 Using a spring to make mounting heavy bearings easier.

The photograph shown in figure 5 was taken during a Prussian blue check (→ figure 6). Strange patterns were apparent on the dismantled bearing's bore and the journal (→ figure 7). The ring was slammed against its seat, but it was not driven up as this would have distorted the result. In this case, oil had to be injected between the journal and the inner ring in order to dismount the latter. The problem turned out to be with the journal, but the lesson is not to slam the bearing against the journal too violently.

Another method for use with heavy bearings that deform under their own weight is to place the bearing on the journal and to screw a mechanical nut against it. The nut is then tightened with an impact spanner and a hammer until the sound of hammer hitting the spanner becomes more metallic. To be frank, this is only something that I'd suggest for people with significant experience of this method.

Overall, the Prussian blue method has a number of shortcomings:

- It gives an idea of the contacts between two surfaces, but it can be misleading.
- It indicates whether there is contact or not, but it doesn't measure deviations.
- The amount of transfer depends on the thickness of the Prussian blue layer.
- Within manufacturing tolerance bearings and journals can achieve less than 80% contact.
- For heavy bearings that deform under their own weight, achieving correct positioning of the bearing on the journal isn't easy. If the bearing is pushed too gently, there won't be enough contact for the test. If too much force is used, there will be too much contact.

However, the Prussian blue method should not be dismissed out of hand as other methods will not check all the surfaces between a bearing and a journal. Measuring the diameter and circularity of a shaft is often done with just three measurements at 120 degree angles from each other. In the case of the journal shown in figure 6 and depending on the axial positioning of the measurements, the circularity could have been either inside or outside tolerances. Only the Prussian blue method could have been used to highlight the areas that were possibly out of tolerances.

Fig. 6 An inner ring ready to be slammed against a Prussian blue coated tapered seat.

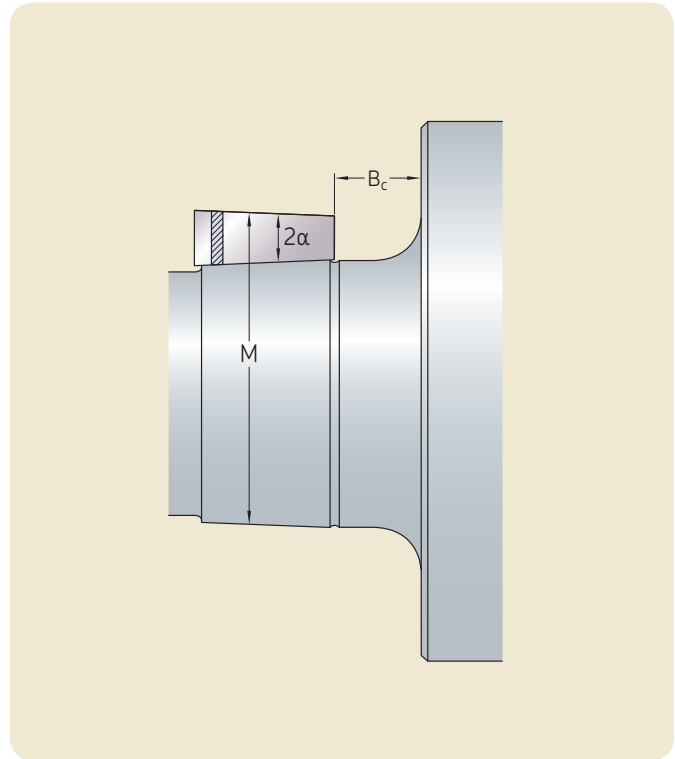

Fig. 8 Gauge method theory

2. Gauge methods

Gauge method theory is quite simple. Figure 8 shows it well, albeit in an exaggerated way.

A straightedge with the same angle as the journal (2α) is placed on the journal. The top edge of the straightedge is parallel to the diametrically opposite side of the journal. The dimension M is the same along the length of the straightedge and the journal. This is still true whatever the angular position of the straightedge around the journal. If dimension M varies, either the angle of the journal taper isn't equal to 2α and/or the journal profile isn't straight.

SKF has two gauge methods – a US one and a European one.

Fig. 7 Strange contact pattern on a journal.



2.1 The USA taper gauge

The USA taper gauge uses a straightedge called a sine bar which is held in place so that its face is flush with the narrower end of the shaft taper (→ figure 9).

Before the sine bar is put in position, a straightedge coated with Prussian blue is moved backwards and forwards along the entire length of the tapered seating (→ figure 10). If blue covers 90% of the seating length for new journals or 80% for old journals, the straightness deviation can be considered acceptable. If not, it doesn't definitely mean that the straightness is out of tolerance, it indicates that a more objective method should be used.

A more objective method is to place a straightedge on two gauge blocks (→ figure 11). The gap between the straightedge and the tapered journal can be measured by passing a feeler gauge along the gap. If a suitable block gauge thickness is chosen, precision can be kept to 0.005 mm +/- the precision class of the tools (e.g. the straightedge) used. Keep in mind, however, that permissible deviations are small (IT5/2 for a 600 mm diameter shaft is only 0.015 mm) and that it isn't that easy to align and secure a straightedge in an exact axial plane.

A quicker alternative is to place a straightedge on a journal and place a lamp behind it. Very experienced fitters are often able to judge by eye whether the deviation in straightness is acceptable for the application or not. Even though I do not have their experience, I sometimes use this method. When I do, I base my resulting decisions on the application and whether the smallest feeler gauges will pass under the straightedge. A 0.03 mm feeler gauge should never pass, but a 0.02 mm can pass if the bearing bore is above 800 mm. However, as the 0.02 mm feeler gauge has poor rigidity, it's best to place it on the journal and then put the straightedge on top before gently pulling it.

Once the straightness is checked, the taper deviation can be measured. This is done by taking measurements at each end of the sine bar with a micrometer. In the SKF literature about the so-called sine bar method, H_1 and H_2 are referred to (→ figure 12). If the shaft taper angle matches the sine bar angle then $H_1 = H_2$.

For each bearing size above a certain bore diameter SKF gives a sine bar designation, a nominal value and tolerance for H_1 and a tolerance for H_2 . H_2 is the measured value for H_1 not the nominal value.

Using the example of a 230/750 CAK/C083W33 spherical roller bearing, H_1 would be 31.3519" (-0.0045; +0.0) with the SKF B-8491-4 sine bar. If the measured value of H_1 is 31.3500" then the narrow end diameter of the tapered seat is within tolerance. The seat taper angle would be in tolerance if the measured value of H_2 equals 31.3500" (-0.0010; +0.0020) i.e. between 31.3490" and 31.3520".

If H_2 is bigger than H_1 , then the actual taper angle is greater than nominal i.e. the taper is more open. If it's smaller, then it's less than nominal i.e. the taper is more closed.

The whole procedure – straightness and taper angle deviation measurements – needs to be repeated at least twice more around the journal every 120 degrees.

Fig. 9 The SKF USA taper gauge.

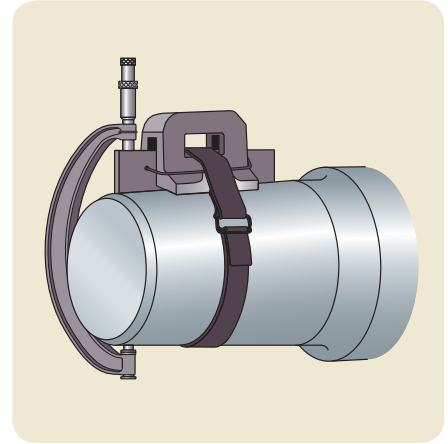

Fig. 10 Using a Prussian blue coated straightedge to check straightness.

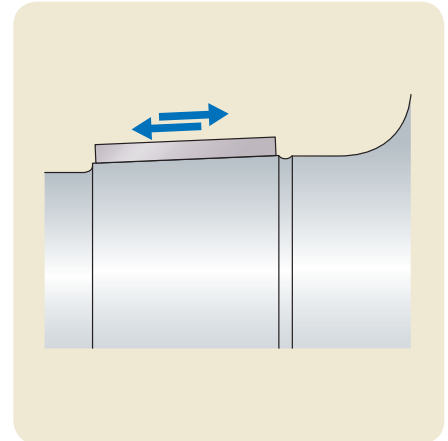

Fig. 11 A straightedge placed on gauge blocks for more objective straightness measurement with feeler gauges.

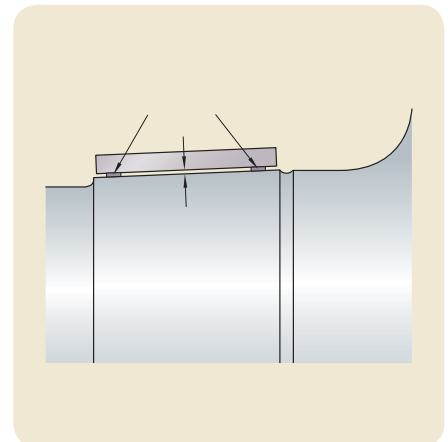
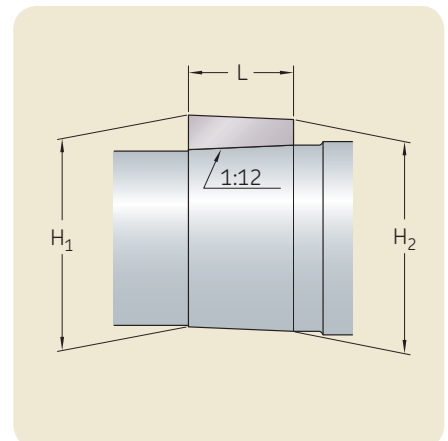

Fig. 12 When the shaft taper angle matches the sine bar angle, $H_1 = H_2$.



2.1 The European taper gauge – The SKF 9205

Before using the SKF 9205 taper gauge, journal straightness is checked as described in the previous section.

The SKF 9205 gauge consists of two gauging pins that are accurately positioned in and guided by a straightedge (→ **figure 13**). Note that with this gauge, the measured value M is to the top of the gauging pins.

With the SKF 9205 gauge, the position of the taper gauge on the journal is based on the known distance (B_c) between the gauge and a reference face. M is calculated for the desired position of the roller bearing on the journal as measured from the centre of the bearing (B_a) and for a chosen distance (B_c) (→ **figure 14**). This will be covered in more detail in the next issue of *SKF Pulp & Paper Practices*.

Like the sine bar method where the engineer measures H_1 first and checks that it is within tolerances, M is measured and checked against tolerances. Then, as H_2 is compared to H_1 , M_1 is compared to M .

Note that I have kept the H_1 , H_2 , M and M_1 naming convention to be consistent with other SKF documents.

The SKF 9205 gauge has two significant advantages over the sine bar gauge:

- 1 The position of the bearing tapered seat on the journal can be checked by comparing measured M and calculated M . If measured M is smaller than calculated M , then the tapered seat is closer to the reference face than expected and vice versa.
- 2 A spacer ring can be made, with a width equal to B_b , against which bearings can be mounted. There is no need to have the bearing; you just measure the deviation from the nominal value of M as the position of the bearing after drive up is known. This has the added advantage of simplifying bearing mounting. There is no need to use feeler gauges or the SKF Drive-up method as you simply dismount the old bearing, check the bearing seat for damage and drive up the new bearing against the spacer ring.

The following example from the cement industry nicely illustrates the second advantage of the SKF 9205 gauge.

Fig. 13 The SKF 9205 taper gauge.

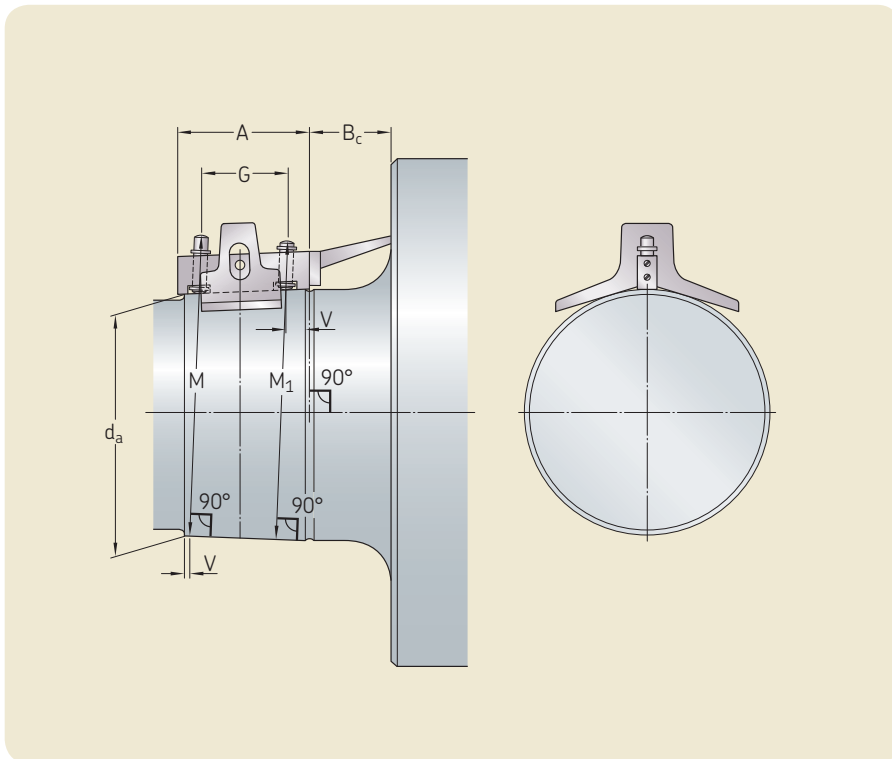
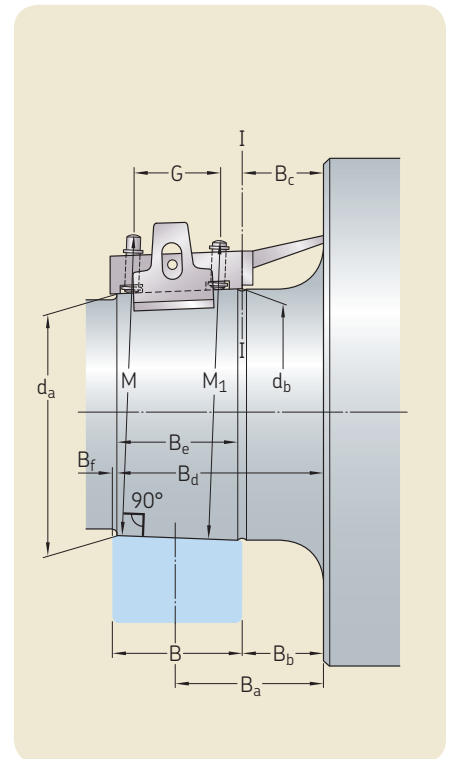

Fig. 14 The value of M depends on the bearing's position on the journal (B_a) and the distance (B_c) from the reference face.



A 241/900 spherical roller bearing weighing 3,500 kg had to be mounted against a spacer ring due to very heavy loads and vibration. The customer's normal procedure was to:

- 1 Mount the bearing using feeler gauges to measure clearance reduction.
- 2 Measure the distance from the bearing side face to the journal shoulder.
- 3 Dismount the bearing and machine a suitable spacer ring.
- 4 Mount the spacer ring and then the bearing against the ring.

With such an approach there is a large risk of error when mounting the bearing with the feeler gauge method as it is not easy to bring the 24 kg rollers into their equilibrium position. Furthermore, mounting such a heavy bearing twice wastes a lot of man hours.

I proposed that the customer measure the tapered bearing seat just after manufacturing with the SKF 9205 taper gauge and send me the measured values. With this information, I was able to tell them the spacer ring width for each journal they made. They could machine spacer rings to the required width and mount the bearings against them when they were delivered. They agreed and we have never had to dismount a bearing due to an incorrect spacer ring width since. I think that this is a good result given that we are talking about 35 new machines over the past 20 years plus all the replacement bearings that have been driven up against the same ring spacers.

I'll finish here, but I will write more about the SKF 9205 taper gauge in the next issue of *SKF Pulp & Paper Practices*. In it, I will cover selecting the right size taper gauge, how to calculate M and ring spacer widths as well as some thoughts about tolerances and measuring uncertainty.

In closing, please remember two things:

- 1 If Prussian blue doesn't result in 80% or 90% coverage, it doesn't mean that the bearing, its seat or both are out of tolerances; it just means that more advanced verification measurements need to be taken.
- 2 When using a micrometer, don't forget to make sure it's calibrated both before and after taking measurements.

Regards,
Philippe Gachet
Senior technical consultant
Philippe.gachet@skf.com



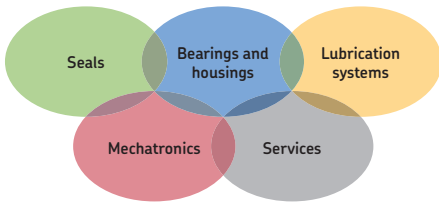

The Power of Knowledge Engineering

Combining products, people, and application-specific knowledge, SKF delivers innovative solutions to equipment manufacturers and production facilities in every major industry worldwide. Having expertise in multiple competence areas supports SKF Life Cycle Management, a proven approach to improving equipment reliability, optimizing operational and energy efficiency and reducing total cost of ownership.

These competence areas include bearings and units, seals, lubrication systems, mechatronics, and a wide range of services, from 3-D computer modelling to cloud-based condition monitoring and asset management services.

SKF's global footprint provides SKF customers with uniform quality standards and worldwide product availability. Our local presence provides direct access to the experience, knowledge and ingenuity of SKF people.

SKF Global Pulp & Paper Segment

Contact/Responsible editor
philippe.gachet@skf.com

© SKF is a registered trademarks of the SKF Group.

© SKF Group 2014

The contents of this publication are the copyright of the publisher and may not be reproduced (even extracts) unless prior written permission is granted. Every care has been taken to ensure the accuracy of the information contained in this publication but no liability can be accepted for any loss or damage whether direct, indirect or consequential arising out of the use of the information contained herein.

PUB 72/S9 11147/12 EN · January 2015



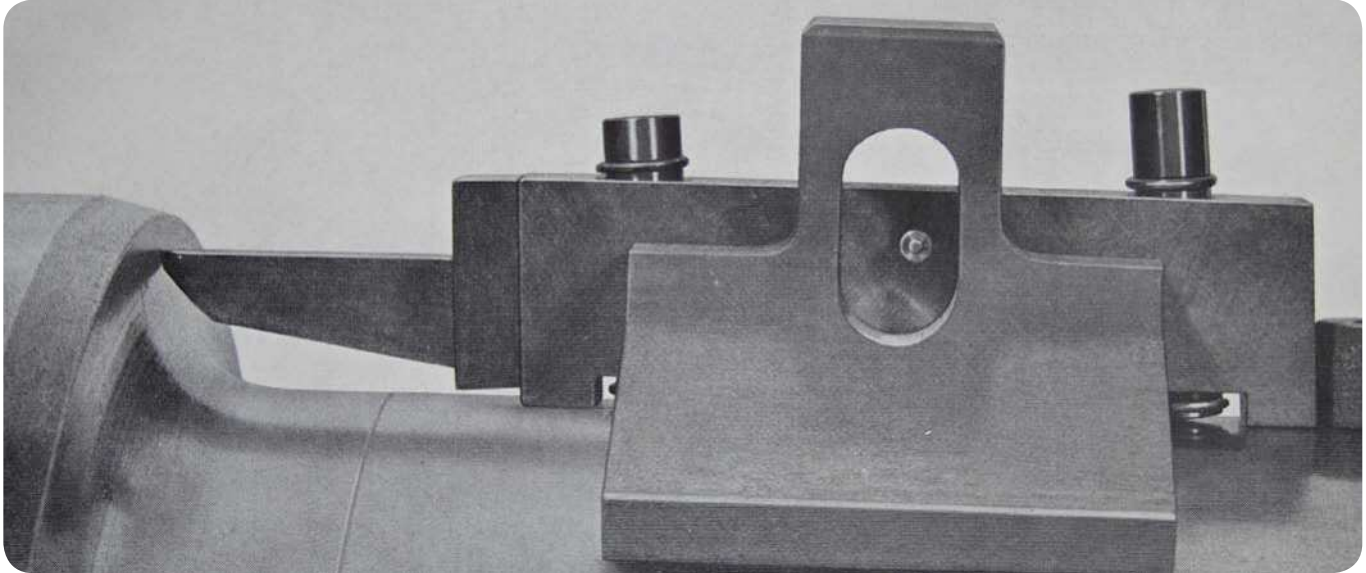

A photograph of the SKF 9205 taper gauge from a 1960s publication.

Don't get rid of your archives!

The archives are the memory of a company. Employees retire, but old documents never have to. Reading them can help you avoid making mistakes that others have made before or reinventing the wheel. Most importantly, they can give insight in to today's situation.

Why does that American paper mill refuse to mount standard SKF spherical roller bearings on its drying cylinders? The archives from the 1970s tell us that they had bearing failures due to ring cracking. This was from a time when SKF supplied bearings with martensitic heat treatment in the USA and ones with bainitic heat treatment in Europe (see *SKF Pulp & Paper Practices* issue 7). The current employees in the mill in question don't know why they only use bearings with case hardened inner rings. They were told to do so by long-retired colleagues.

Why does this mill select bearing clearance class based on a rule of thumb that no longer exists in today's SKF literature? The archives can tell us that the rule was used for fan applications before the 1970s. Further investigation would reveal that an engineer started to use it for other applications and that he was involved in training others. One of the people he trained started to use the rule with

speed ratings rather than speed limits and become an "expert". And, so, the error spread.

Even though the archives aren't complete, I still have the chance to access some technical documents from the early 1920s and 1930s. Some consider them obsolete and think they should be removed to make space. This would be a mistake. The cover photograph above, for example, is from a document about the SKF 9205 taper gauge published in 1961. Without our archives, we wouldn't have been able to ascertain that a strange value in a table was the result of an error in an update from the 1980s which was reproduced in subsequent publications. I fear that it won't be so easy to access today's electronic files for such information in future decades.

Regards,
Philippe Gachet
Senior technical consultant
SKF Pulp & Paper global segment



Checking tapered journal geometry (continued)

In the previous issue of *SKF Pulp & Paper Practices*, I covered checking tapered journal geometry with the imprecise and subjective Prussian blue method. I also wrote about more objective and accurate approaches i.e. the sine bar method and the SKF 9205 taper gauge method.

In this issue, you'll learn more about the SKF 9205 taper gauge, but let's run through some important reminders first.

1. Tapered bores

Most SKF spherical roller bearings and CARB toroidal roller bearings designed for tapered journals have a 1:12 bore taper (denoted by the suffix K). The exception is bearings from the 240, 241, C40 and C41 series that have 1:30 taper bores (suffix K30).

When you move a distance (L) up a 1:12 taper from a diameter (d) towards a larger one (d_1), $d_1 = d + (L/12)$. With a 1:30 taper, $d_1 = d + (L/30)$.

Calculations are simple once this is understood. For example, a 24172 ECK30J/W33 has a nominal bore diameter of 360 mm at the narrow end of the taper and its width is 243 mm. The bore diameter at the wide end of the taper is $360 + (240/30) = 368,10$ mm.

What about a 23184 CKJ/C4W33 with bore damage caused by ring rotation on the journal? It can be repaired at an SKF remanufacturing centre, but grinding is involved leading to a 0,1 mm increase in diameter along the taper. What influence does this have on the bearing position on the journal? Knowing that $d_1 = d + 0,1$, the question is what is L?

$$d_1 = d + (L/12)$$

$$< = > d + 0,1 = d + (L/12)$$

$$< = > 0,1 = L/12$$

$$0,1 \times 12 = 1,2 \text{ mm}$$

So, the bearing will be 1,2 mm closer to the middle of the roll.

2. How to use the SKF 9205 taper gauge

See issue 13 of *SKF Pulp & Paper Practices*. If you haven't already read it, please do so before reading on. If you don't, the rest of this issue will be hard to follow.

2.1 What does the SKF 9205 taper gauge look like?

The SKF 9205 taper gauge is a straightedge with two gauge pins. There are ten designs available, five for 1:30 tapers and five for 1:12 tapers (→ figure 1).

The designation for 1:12 taper straightedges is SKF 920512 and it's SKF 920530 for 1:30 tapers. The distance between the two gauging pins in millimetres, G, is indicated as a suffix in the designation (→ figure 2). So, for example, SKF 920512-80 is designed for 1:12 tapers and the distance between the two gauging pins is 80 mm. The straightedges are available with different G measurements i.e. 50 mm, 80 mm, 130 mm, 210 mm and 350 mm.

The straightedge is positioned at a distance, B_c , from the reference face using a distance piece. The distance piece is attached to the straightedge and can be custom made for a specific application (see the cover of this issue of *SKF Pulp & Paper Practices*) or a less accurate adjustable one can be used (→ figure 3).

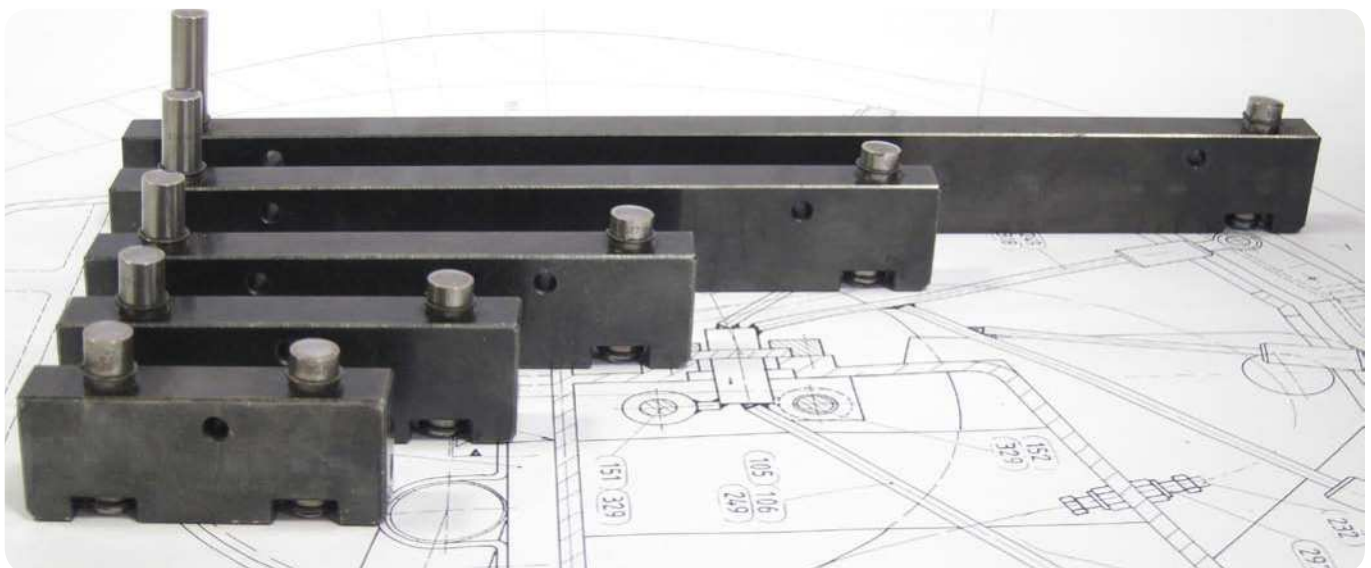

Fig. 1 Five straightedges of various lengths for 1:12 tapers.

The straightedge is held in place by one or two saddles and is secured using locking pins. A magnet is placed behind it to prevent movement during measuring. Straps are used to hold the taper gauge in position when necessary.

A complete SKF taper gauge set includes five straightedges, two saddles, two straps, two magnets and an adjustable distance piece (→ figure 4).

2.2 Calculations necessary to use the SKF 9205 taper gauge

In the following sections, I will provide worked examples for a SKF 241/600 ECAK30/C083W33 bearing in a plain press roll application (→ figure 5).

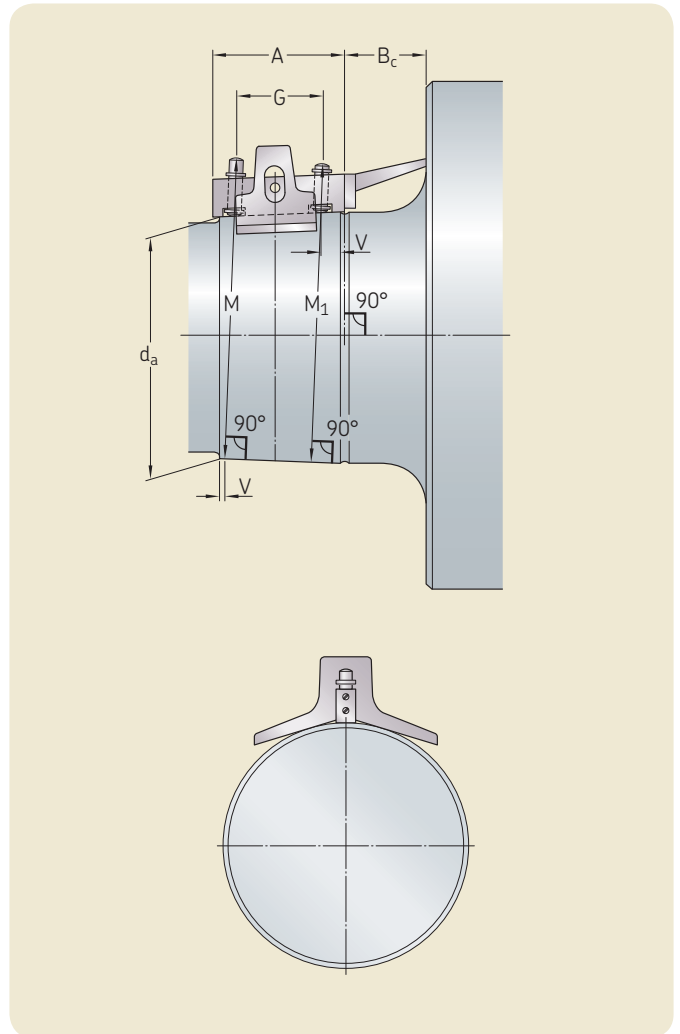

Fig. 2 The SKF 9205 taper gauge on a tapered journal.

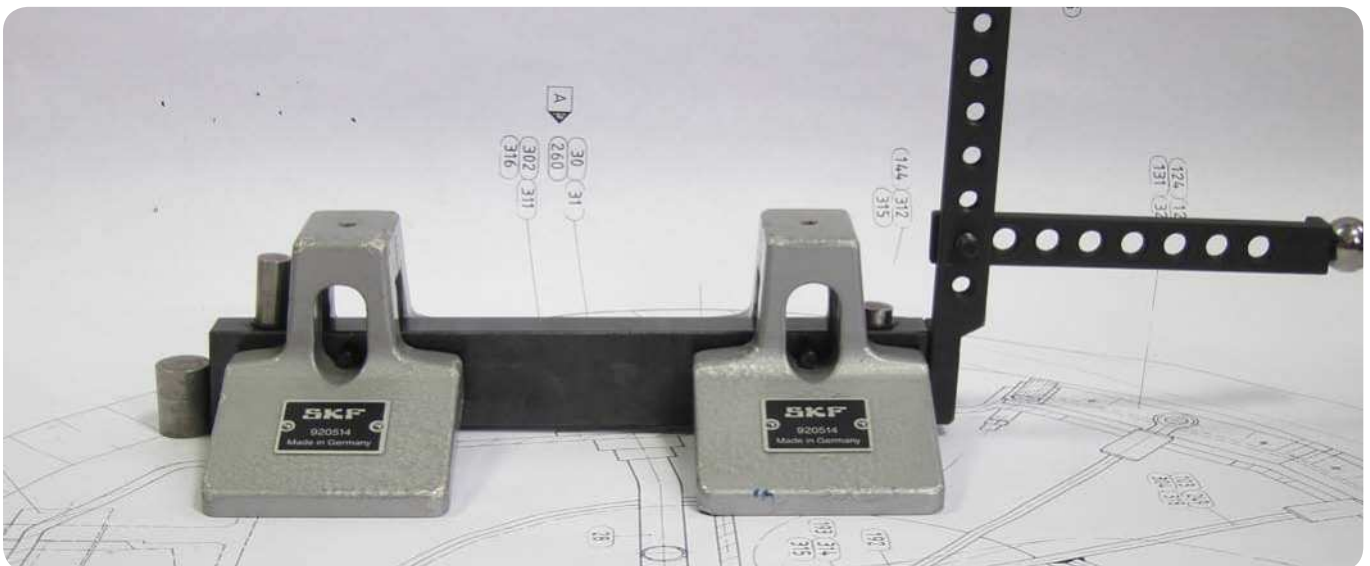

Fig. 3 An SKF 920512-210 taper gauge with two saddles (SKF 920514), a permanent magnet and an adjustable distance piece.

2.2.1 Nominal journal diameter

The dimension, B_a , is used as a basis when measuring a tapered journal with a SKF 9205 taper gauge. It's the distance from the centre of the bearing as finally mounted to the reference face of the journal (→ figure 6).

Note:

After mounting, the centre of our SKF 241/600 ECAK30/C083W33 bearing is 490 mm from the journal shoulder reference face and the taper width, B_e , is 370 mm.

Knowing B_a and the bearing dimensions, it is possible to calculate the nominal journal diameter, d_a , and its distance, B_d , from the reference face.

The nominal journal diameter, d_a , is bigger than the bearing bore diameter, d .

The bearing nominal bore, d , is the diameter of the inner ring bore taper in the radial plane passing by the ring face. In reality, between the ring face and the bore there is a chamfer and there's no contact between the journal and bearing. There is contact further up the bore after the chamfer. If B_f is equal to the chamfer radius, then contact occurs at a distance of B_f from the ring face (→ figure 6).

The diameter of the taper increases by a value equal to B_f/K . Remember that K equals either 12 or 30 depending on the taper angle. The default value for B_f can be found in table 1. For SKF 241/600 ECAK30/C083W33, $B_f = 10$ mm.

Note that bearings are manufactured with tolerances for both the nominal bore diameter and the taper deviation (→ figure 7).



Fig. 4 Complete SKF 920512 taper gauge set.

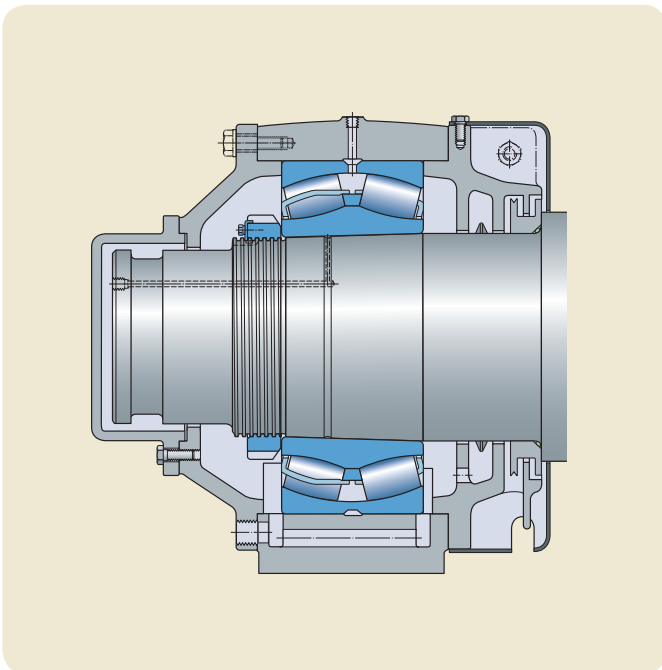

Fig. 5 Example of a plain press roll bearing arrangement from the SKF Rolling bearings in paper machines handbook.

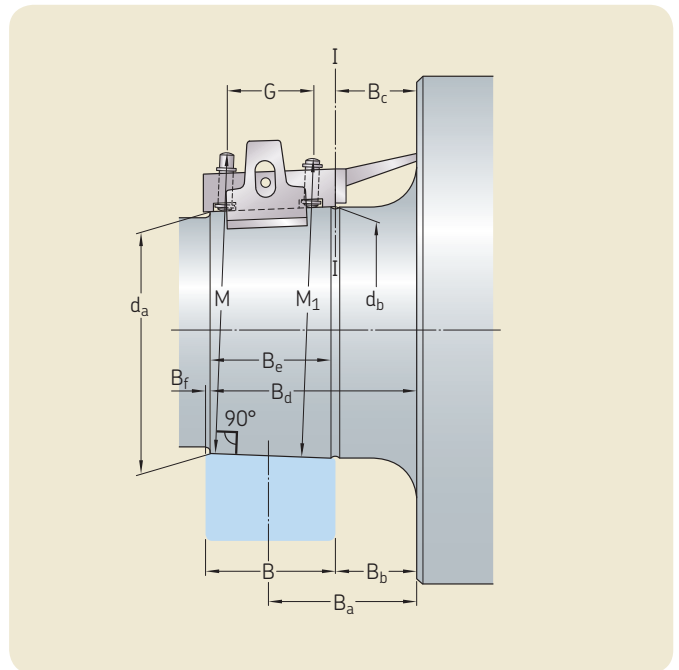

Fig. 6 The dimensions required for using the SKF 9205 taper gauge.

Note:

For SKF 241/600 ECAK30/C083W33, Δd_{mp} , which is the deviation of the bore diameter from the nominal, is between 0,000 and +0,050 mm. This means that, in reality, the bearing narrowest bore diameter is between 600,000 and 600,050 mm.

If the taper bore angle is perfect, there would be the same deviation in all radial planes along the taper. If this is not the case, the bearing bore angle is manufactured within certain tolerances.

$(\Delta d_{1mp} - \Delta d_{mp})$ is always positive. Δd_{1mp} is the deviation of the mean bore diameter at the theoretical large end of a tapered bore from the nominal. For the SKF 241/600 ECAK30/C083W33,

$(\Delta d_{1mp} - \Delta d_{mp})$ is between 0,000 and +0,070 mm. Values can be found on **pages 145 and 146** of the *SKF rolling bearings catalogue* (SKF publication number 10 000).

To calculate the nominal journal diameter, d_a , the mean value of the bore tolerance of the bearing, T_m , and the taper deviation from the nominal are taken into account. T_m is added to d (\rightarrow **table 1** for the T_m values for normal precision SKF bearings).

Note:

For better understanding, let's calculate the T_m value for SKF 241/600 ECAK30/C083W33. The bearing nominal bore d is 600 mm and the real value after manufacturing is somewhere between 600,000 and 600,050 mm. The mean value is 600,025 mm.

If the taper angle is perfect and the mean value of 600,025 mm is taken, the diameter at the other side of the inner ring will be $600,025 + 375/30$ (since the bearing width, B , is 375 mm and the taper is 1:30) i.e. 612,525 mm. However, the taper angle isn't perfect and the deviation is 0,000; +0,070 in this case. The mean deviation due to taper angle tolerance is then $0,070/2 = 0,035$ mm. The mean diameter at the widest bore side is $612,525 + 0,035 = 612,560$ mm.

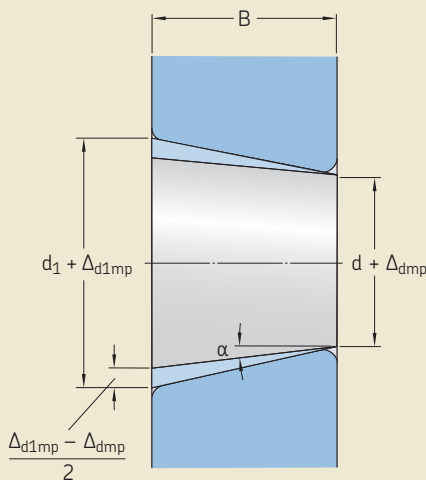

Fig. 7 Tolerances for 1:30 taper bores.

The mean value at the middle of the bearing = $(600,025 + 612,560)/2 = 606,2925$ mm. The nominal diameter at the middle of the bearing = $600 + [(375)/2]/30 = 606,250$ mm. The mean deviation = $T_m = 606,2925 - 606,250 = 0,0425$ (which we round to 0,042 or 0,043 mm).

Once understood, the calculation can be done more quickly since bearing width has no influence. The mean deviation at both the narrow end and the wide end of the taper is 0,025 mm. With the addition of the mean deviation due to the taper (0,035 mm), there is 0,060 mm deviation at the wide end. Calculating the mean deviation of the two gives you T_m i.e. $(0,025 \text{ mm} + 0,060 \text{ mm})/2 = 0,0425$ mm.

Now you know how to calculate T_m for bearings other than the SKF normal precision class ones.

For bearings mounted with an interference fit, the taper journal at the bearing's final mounted position needs to be larger than the bearing bore. As a rule of thumb, there's a factor of 1,1 which is an average value for the relationship between the interference of the inner ring on the journal and the actual reduction in bearing radial clearance.

Be careful though as this factor is only valid for solid journals and journals with a bore diameter below half the nominal journal diameter. Or, to make things easier, simply take half the bearing nominal bore diameter.

If the journal bore is larger than half the bearing nominal bore, the factor should be increased. In such cases, I advise contacting the local SKF application engineering department.

Nominal bore diameter of bearing d		T_m		B_f
Over	Include	1:12 taper	1:30 taper	
100	120	0,026	0,019	3
120	140	0,030	0,023	3
140	180	0,030	0,023	4
180	250	0,035	0,027	4
250	315	0,039	0,031	6
315	400	0,043	0,034	6
400	500	0,047	0,038	8
500	560	0,053	0,043	8
560	630	0,053	0,043	10
630	800	0,060	0,063	10
800	1 000	0,068	0,075	10
1 000	1 250	0,079	0,091	12
1 250	1 600	0,094	0,111	15
1 600	2 000	0,113	0,138	15

Table 1 Values for T_m and B_f for normal precision class SKF bearings only.

In general, SKF recommends a tight fit giving a clearance reduction of 0,0005 of the nominal bearing bore, d , for pulp and paper applications. Some pulp and paper applications, however, require tighter fits.

As such, an adjustment must be added to d in order to calculate d_a :
 $1,1 \times 0,0005 \times d = 0,00055 d$.

Finally:

$$d_a = d + (B_f/K) + T_m + 0,00055 d$$

$$d_a = 1,00055 d + B_f/K + T_m$$

(Based on **figure 6**) $B_d = B_a + B/2 - B_f$

Note:

For SKF 241/600 ECAK30/C083W33:
 $d_a = (1,00055 \times 600) + (10/30) + 0,042 = 600,7053 \text{ mm}$
 $B_d = 490 + 375/2 - 10 = 667,500 \text{ mm}$

2.2.2 Selecting the right straightedge

For accurate measuring results, the distance, G , between the gauging pins should cover as much of the width of the taper, B_e , as possible. However, G is limited by the space needed to accommodate the gauge pins and micrometer screw at each end of the taper (see the V distances shown in **figure 3**).

For 1:30 tapers, $G < B_e - (2V) - 0,02 d_a$
 For 1:12 tapers, $G < B_e - (2V) - 0,05 d_a$

If d_a is equal to or smaller than 180 mm, then V should be at least 5 mm.

If d_a is greater than 180 mm, and up to equal to 400 mm, then V should be at least 7 mm.

If d_a is greater than 400 mm, then V should be at least 9 mm.

0,02 d_a and 0,05 d_a are approximations based on the diameter of the journal and the taper angle that should allow the micrometer to contact the taper and measure M at the narrow end of the taper bore.

Note:

For SKF 241/600 ECAK30/C083W33, d_a is greater than 400 mm so the minimum value for V is 9 mm.

$$B_e = 370 \text{ mm}$$

$$d_a = 600,7053 \text{ mm}$$

$$G < 370 - (2 \times 9) - (0,02 \times 600,7053) = 339,986 \text{ mm}$$

As such, the straightedge SKF 920530-210 should be chosen.

2.2.3 Selecting the right distance piece length

The distance piece length must allow accurate measurements. The centres of the gauging pins are positioned 20 mm from the end face of the SKF straightedges. The value V must be added to the minimum length or subtracted from the maximum length when selecting the distance piece length. The position of the narrower end of the taper and the wider end must also be taken into account.

Minimum length:

$$B_c \text{ min} = B_d - B_e - 20 + V$$

Maximum length:

$$\text{For 1:30 tapers: } B_c \text{ max} = B_d - G - 20 - V - 0,02 d_a$$

$$\text{For 1:12 tapers: } B_c \text{ max} = B_d - G - 20 - V - 0,05 d_a$$

Note:

For SKF 241/600 ECAK30/C083W33, $B_d = 667,500 \text{ mm}$,
 $B_e = 370 \text{ mm}$, $V = 9 \text{ mm}$, G is 210 mm and $d_a = 600,7053 \text{ mm}$.
 As such, B_c must be between 286,5 mm and 416,5 mm and we'd choose a 350 mm distance piece. Therefore, $B_c = 350 \text{ mm}$.

2.2.4 Calculating the nominal value for M

Having selected a straightedge and a distance piece of suitable length, the diameter d_b in the plane I-I is calculated (\rightarrow **figure 6**). This plane coincides with the inner end face of the straightedge.

$$d_b = d_a + (B_d - B_c)/k$$

Note:

For SKF 241/600 ECAK30/C083W33, $B_d = 667,500 \text{ mm}$,
 $B_c = 350 \text{ mm}$, $k = 30$ and $d_a = 600,7053 \text{ mm}$
 $d_b = 600,7053 + (667,500 - 350)/30 = 611,2886 \text{ mm}$

Using d_b , the nominal value for M is calculated using the relevant equation below.

$$\text{For 1:30 tapers: } M = d_b - 0,000139 d_b + 44,346$$

$$\text{For 1:12 tapers: } M = d_b - 0,000867 d_b + 43,413$$

Note:

For SKF 241/600 ECAK30/C083W33, $d_b = 611,2886 \text{ mm}$, M then equals $611,2886 - (0,000139 \times 611,2886) + 44,346 = 655,5496 \text{ mm}$

2.3 Tolerances for the tapered journal

When machining a journal, a certain tolerance must be allowed which applies to the dimensions M and M_1-M .

Over the years, tolerances have changed. Some changes are small like the tolerance for M which was $j9$ and is now $js9$ (E). Others, like the changes on the taper angle deviation, are much more important. Some old journals on machines that are still in operation today are out of tolerance by today's standards.

Note:

For SKF 241/600 ECAK30/C083W33 $d = 600 \text{ mm}$
 $js9$ (E) for 600 mm is $\pm 0,087 \text{ mm}$
 So $M = 655,5496 \text{ mm} (-0,087 ; +0,087)$

Different approaches were used when the tolerances for tapered journal seatings were being established. The European system was based on the permissible angle deviation for the journal taper being on the plus side, like we do for bearings, and the tolerance value was related to the nominal diameter of the journal. In contrast, the US approach was to have a permissible deviation on the minus side and

to use the nominal width of the bearing. These different approaches have, understandably, led to practical difficulties.

Since 1986, the permissible angle deviation for machining the taper is a plus/minus tolerance in accordance with $\pm IT7/2$. The value is determined in relation to the bearing width.

Note:

For SKF 241/600 ECAK30/C083W33, $B = 375$ and $IT7$ for 375 mm is 0,057 mm.
 $\pm IT7/2 = (-0,0285; +0,0285)$

As the gauge pins are separated by a distance, G , which is not equal to the bearing width, B , the tolerance on $M_1 - M$ will be equal to $(G/B) \times (\pm IT7/2)$

Note:

For SKF 241/600 ECAK30/C083W33, $G = 210$, $B = 375$ and $\pm IT7/2 = \pm 0,0285$ mm.
 So $M_1 - M$ limits are $(210/375) \times (\pm 0,0285) = \pm 0,016$ mm

As increased reduced run-out tolerances are needed for faster-running modern machines, the radial deviations from circularity have changed. In the past, $IT6/2$ was used with $IT5/2$ recommended for cases requiring reduced run-out tolerances. Today, $IT5/2$ is used and $IT4/2$ is recommended when higher accuracy is needed. $IT4/2$ should be used when bearings with reduced run-out tolerances – like SKF's C08, VQ424 and VA460 bearings – are required. The value is determined in relation to the nominal bearing bore diameter and applies to both M and M_1 maximum deviation values as measure at several locations around the journal.

Note:

SKF 241/600 ECAK30/C083W33 has a C08 suffix so the journal should have a circularity following $IT4/2$.

Be careful though as circularity deviation definition is based on the radius, not the diameter. So, the value must be doubled when gauging with a micrometer, thus $IT4$ not $IT4/2$. $IT4$ for 600 mm is 0,022 mm.

Most documents didn't show $IT4$ for nominal dimensions above 500 mm. You can find it in the norm ISO 286-1:2010.

So, after measuring M and M_1 in several positions around the journal, maximum measured M minus minimum measured M value should not be above 0,022 mm. The same applies for M_1 .

2.4 Straightness

Straightness tolerance is $IT5/2$ and is based on the bearing diameter. As straightness deviation applies to the generatrices of the taper, permissible tolerance is doubled if measurement is done with a micrometer over the diameter.

Note:

For SKF 241/600 ECAK30/C083W33, $IT5/2$ is 0,016 mm. When measuring with a micrometer over the diameter, the tolerance is 0,032 mm.

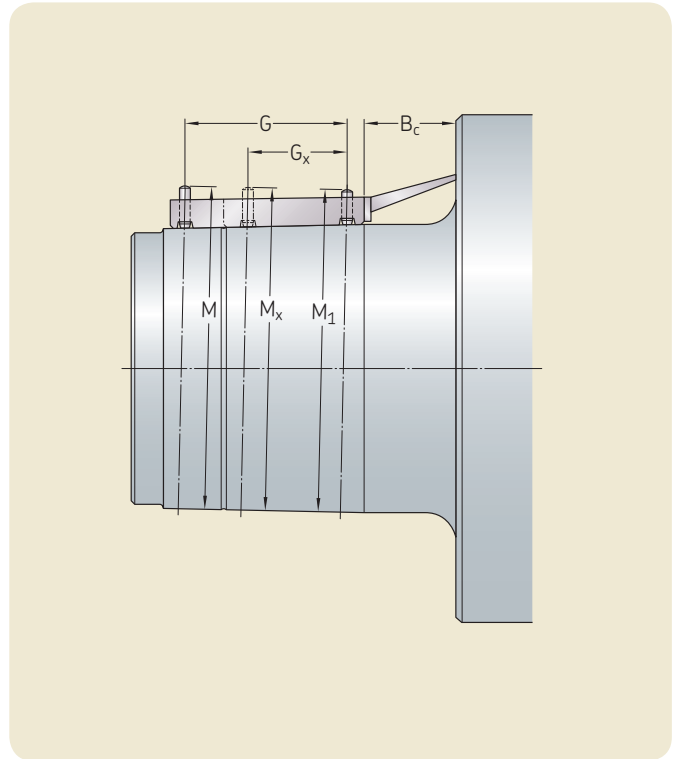

Fig. 8 Checking straightness with the SKF 9205 taper gauge.

The straightness of a tapered seating is quite difficult to measure, but some methods were explained in the previous issue of *SKF Pulp and Paper Practices*.

The SKF 9205 gauge can be used to estimate straightness. The gauge pin closest to the distance piece always has the same height and will always be in the same position regardless of the length of the straightedge. This means that M values are the same if the same distance piece is used.

Taper angle deviation as expressed by $M_1 - M$ must always be taken into account. If $M_1 - M_x$ have the same angle deviation, there's perfect straightness (\rightarrow figure 8). Given that G_x is smaller, $M_1 - M$ and $M_1 - M_x$ will have the same angle deviation if $M_1 - M_x = (G_x/G) \cdot (M_1 - M)$.

The straightness of the tapered seating is within tolerance if, at the measured points,

$$(G_x/G) \cdot (M_1 - M) - IT5/2 < M_1 - M_x < (G_x/G) \cdot (M_1 - M) + IT5/2$$

Note that this is valid for one axial plane so M , M_1 and M_x must be in the same axial plane.

Note:

For SKF 241/600 ECAK30/C083W33, the calculated M value will remain equal to 655,5496 mm with the following SKF straightedges: 920530-50, 920530-80, 920530-130, 920530-210. Let's suppose that $M = 655,550$ mm and that $M_1 = 655,560$ mm with the SKF 920530-210 straightedge. The next measurement is undertaken with the SKF 920530-130 and the same distance piece.

$$G = 210$$

$$G_x = 130$$

$$G_x/G = 0,6190$$

$$M_1 - M = 0,010$$

$$IT5/2 = 0,016$$

$$(0,619 \times 0,010) - 0,016 < M_1 - M_x < (0,619 \times 0,010) + 0,016$$

$$-0,0098 < M_1 - M_x < 0,0222$$

So, the straightness based on three points is within tolerance if, after rounding the values,

$$655,538 < M_x < 655,570.$$

This method should be used in conjunction with the Prussian blue method which will indicate the contact percentage. If that's below the recommended level, select a straightedge with a gauging pin position suitable for the area that needs to be measured.

If no suitable straightedge is available, it's possible to take measurements using another distance piece and a smaller straightedge (→ figure 9). While the gauges are shown spaced apart by 180° for ease of understanding, in reality it's important that comparative measurements of M , M_1 , M_x and M_{1x} are taken at the same position on the journal.

In figure 9, M_x is the diameter where there is a supposed straightness deviation. A new distance piece is added so that the smaller straightedge is at a distance, B_g , from the reference face. The distance between the M_1 and M_x gauging pins is now G_1 .

$$G_1 = G_x + B_g - B_c.$$

As the smaller straightedge is now further away from the reference face, the M_x value will be smaller than M and M_1 . The difference in diameter which is $(B_g - B_c)/k$, must be added to compare M_1 and M_x .

$$M_1 - M_x = (G_1/G) \cdot (M_1 - M) + (B_g - B_c)/k$$

The straightness is within tolerance if:

$$(G_1/G) \cdot (M_1 - M) + (B_g - B_c)/k - IT5/2 < M_1 - M_x < (G_1/G) \cdot (M_1 - M) + (B_g - B_c)/k + IT5/2$$

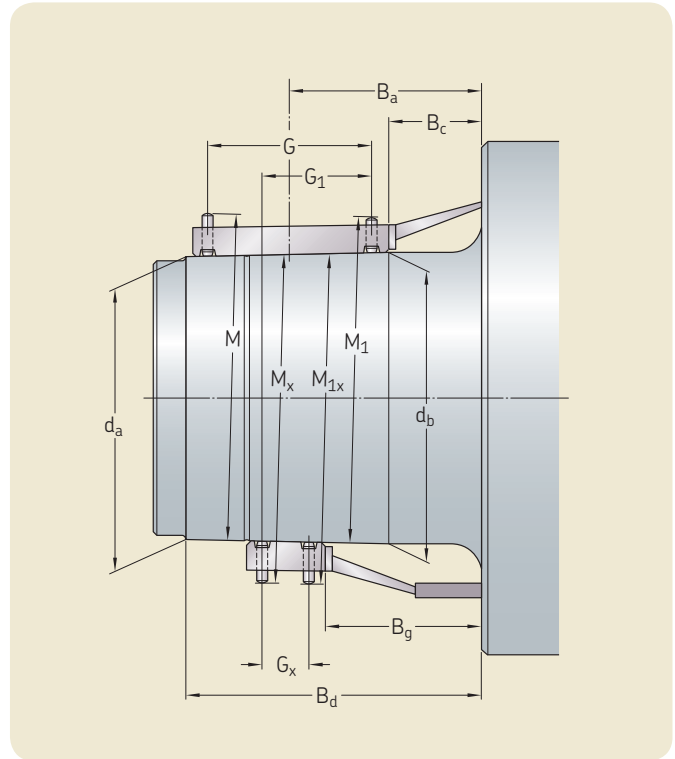

Fig. 9 Checking straightness with the SKF 9205 taper gauge and two distance pieces.

2.5 Determining the width of the spacer ring

It's possible to determine the width of a spacer ring against which a bearing will be driven up for a correct tight fit for bearings with a 1:30 taper.

Note that some bearings with a 1:12 taper can also be mounted in this way. Such bearings must be manufactured with the reference face at the large end of the taper and to close bore tolerances applying to a taper of 1:30. These bearings have special designations and prices.

Note:

SKF 241/600 ECAK30/C083W33 has a taper of 1:30 and can be mounted against a spacer ring whose width is determined in advance with the SKF 9205 taper gauge.

The nominal width of the ring is (→ figure 6):

$$B_b = B_d + B_f - B$$

where all dimensions are nominal.

The actual width of the ring for the same journal is obtained using:

$$B_{be} = B_b + k \cdot \Delta M$$

Where ΔM is the measured positive or negative deviation from the nominal M deviation.

Note:

For SKF 241/600 ECAK30/C083W33, nominal $M = 655,5496$ mm.

Measured M value is $655,550$ mm at the 0° (the top) position.

Measured M value is $655,570$ mm at the 45° position.

Measured M value is $655,562$ mm at the 90° position.

Measured M value is $655,559$ mm at the 135° position.

The average measured value is then $655,5603$ mm

$$\Delta M = 655,5603 - 655,5496 = 0,0107 \text{ mm}$$

$$B_d = 667,500 \text{ mm}$$

$$B_f = 10 \text{ mm}$$

$$B = 375 \text{ mm}$$

$$B_{be} = 667,5 + 10 - 375 + (30 \times 0,0107) = 302,819 \text{ mm}$$

For the rings to have the necessary adjustment allowance, they must be manufactured wider:

$$B_h = B_b + k.h$$

Where h is the upper limit for M in accordance of js9 $\text{\textcircled{E}}$ determined in accordance to the bearing bore diameter.

Note:

For SKF 241/600 ECAK30/C083W33, js9 $\text{\textcircled{E}}$ for 600 mm is $\pm 0,087$ mm.

$$B_h = 667,5 + 10 - 375 + (30 \times 0,087) = 305,110 \text{ mm.}$$

Several 305,110 mm width spacer rings should be made and then machined or ground to a specific width after having measured the M values around the journal and calculated the average M .

Note that each adjusted spacer ring is for one unique journal and should not be used with another one.

3. Measuring uncertainty

Remember that even though the tool is called a micrometer, it isn't able to measure with a precision of one micron. Other things can affect the accuracy of a measurement too e.g. the influence of the tool user's body heat. A leading tool manufacturer gives an example of this based on the use of a 300 mm micrometer for 15 minutes in a room that's at a temperature of 20°C which adds $12 \mu\text{m}$.

The direction of measurement is also important. Even if a journal has perfect circularity, the micrometer will measure a deviation between the vertical and horizontal positions as it will deform under its own weight.

To minimise uncertainty and error it's important to always check a micrometer before and after measurement using a standard at ambient temperature.

In the absence of other information, a simple rule of thumb is that measuring uncertainty when using a micrometer is estimated to be $\pm 0,1$ IT9/2.

Note:

For SKF 241/600 ECAK30/C083W33, the uncertainty when measuring M would be $\pm 0,0087$ mm.

For better accuracy, especially for journals supported by C08, VQ424 and VA460 bearings that have reduced run-out tolerances, a dial indicator should be used. Then, estimated uncertainty falls to $\pm 0,1$ IT7/2

Note:

Our SKF 241/600 ECAK30/C083W33 is a C08 bearing, so a dial indicator should be used. The uncertainty is then estimated to be $\pm 0,0035$ mm.

To conclude, the SKF 9205 taper gauge is a good tool that will never run out of battery power and which can withstand submersion in oil. At first, it can seem like a complicated tool to use due to all the equations involved. These can, of course, be run using a spreadsheet so that you simply need to enter input data.

I have tried to make my explanation of the tool's use as simple as possible by giving worked examples throughout this issue of SKF Pulp & Paper Practices. I will also add that once the SKF 9205 principle is understood, it becomes obvious and you will never forget it. It's just the first few times using it that are difficult.



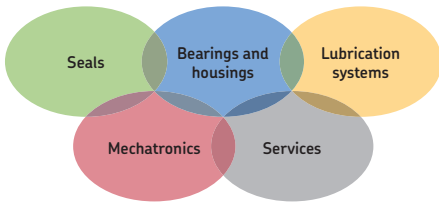

The Power of Knowledge Engineering

Combining products, people, and application-specific knowledge, SKF delivers innovative solutions to equipment manufacturers and production facilities in every major industry worldwide. Having expertise in multiple competence areas supports SKF Life Cycle Management, a proven approach to improving equipment reliability, optimizing operational and energy efficiency and reducing total cost of ownership.

These competence areas include bearings and units, seals, lubrication systems, mechatronics, and a wide range of services, from 3-D computer modelling to cloud-based condition monitoring and asset management services.

SKF's global footprint provides SKF customers with uniform quality standards and worldwide product availability. Our local presence provides direct access to the experience, knowledge and ingenuity of SKF people.

SKF Global Pulp & Paper
Segment

Contact/Responsible editor
philippe.gachet@skf.com

© SKF is a registered trademarks of the SKF Group.

© SKF Group 2015

The contents of this publication are the copyright of the publisher and may not be reproduced (even extracts) unless prior written permission is granted. Every care has been taken to ensure the accuracy of the information contained in this publication but no liability can be accepted for any loss or damage whether direct, indirect or consequential arising out of the use of the information contained herein.

PUB 72/S9 11147/13 EN · April 2015





Digital vs. paper information

Last year I was emailed a detailed drawing of a suction roll. The problem is that I have a 24 inch computer monitor and I could not make out any detail if I displayed the whole thing. This meant that I spent a lot of time zooming in and out on different parts of the drawing.

Two months later I received a copy of the 1m by 4m drawing rolled up in a cardboard tube. I mounted it on the wall of my office and very quickly came to the conclusion that there was either a design error or a drawing error. This was something I had missed when looking at it on my monitor.

With the drawing on my wall, I was able to discuss the bearing assembly with colleagues and make some quick modifications with pencil. This was not the first and doubtless will not be the last time I felt nostalgic for the days of drawing tables and paper drawings. One day perhaps, I might have a large A0 size monitor with good screen resolution, but I cannot see it being as light and as portable as a piece of paper of the same size.

Two weeks ago, I went off-road. In the past, I would have used a 1:25 000 scale paper map and a compass or relied on GPS. This time I made the mistake of just taking my smartphone and an app with a 1:25 000 scale map on it. As you've probably guessed by now,

I was only able to see the details of a very small part of the map. You can imagine how much time I wasted zooming in and out checking where I wanted to go and how I should get there. In hindsight, I'd have been much better off sticking to my usual method which is a paper map for an overview and GPS as the main tool for directions while driving.

Some of my colleagues argue that an electronic device allows you to travel with more catalogues, brochures and technical documents than you could realistically carry. This is true and I do use my smartphone and laptops during customer visits to search for information in the SKF rolling bearings catalogue, for example. However, I always use hard copies when I'm in the office as it's much easier to turn the page and I don't need to be constantly zooming in and out. For me, digital information is a supplement to, rather than a replacement for, paper products.

Regards,
Philippe Gachet
Senior technical consultant
SKF Pulp & Paper global segment



Fulfilling promises and responding to questions

In this issue of SKF Pulp & Paper Practices I will address a number of different issues:

- 1 Whether there is a method to make sure that there is a good shaft/bearing contact when checking the seat with Prussian blue.**
- 2 The number of diameter measurements needed to check ovality.**
- 3 T_m values for high precision radial run out bearings e.g. SKF C08, VQ424 and VA460 variants.**
- 4 Bearing failure pie chart differences.**

1. Good shaft/bearing contact when checking a bearing seat with Prussian blue?

I was asked a question by an equipment manufacturer after *issue 13 of SKF Pulp & Paper Practices* was published. He wanted to know whether there was a reliable and accurate way to ensure that a bearing has intimate contact with its seat. He was talking about heavy bearings which need a crane to lift them. A typical example would be a Yankee bearing (→ **figure 1**).

As you can see, the bearing is suspended by a fixed length strap from a crane. If you were to push this bearing without moving the crane at the same speed, the bearing would move upwards. A maintenance worker could not slam this bearing in place. If it was held in place by hand, it would be resting on the top of the journal. This is why most of the Prussian blue can be seen on the top.

I listed my recommendations on what to do about this in *issue 13*. They included using a spring on the crane strap and the use of the nut and hammer method to ensure good contact without too much drive-up.

The equipment manufacturer wanted to know if there was a better and less subjective approach than my nut and hammer method that didn't require experienced fitters. One that relied on hydraulic pressure or applying torque to a lock nut perhaps. I promised to give him an answer in *issue 15 of SKF Practices* and a promise is a promise.

Fig. 1 Prussian blue check with poor bearing/shaft contact

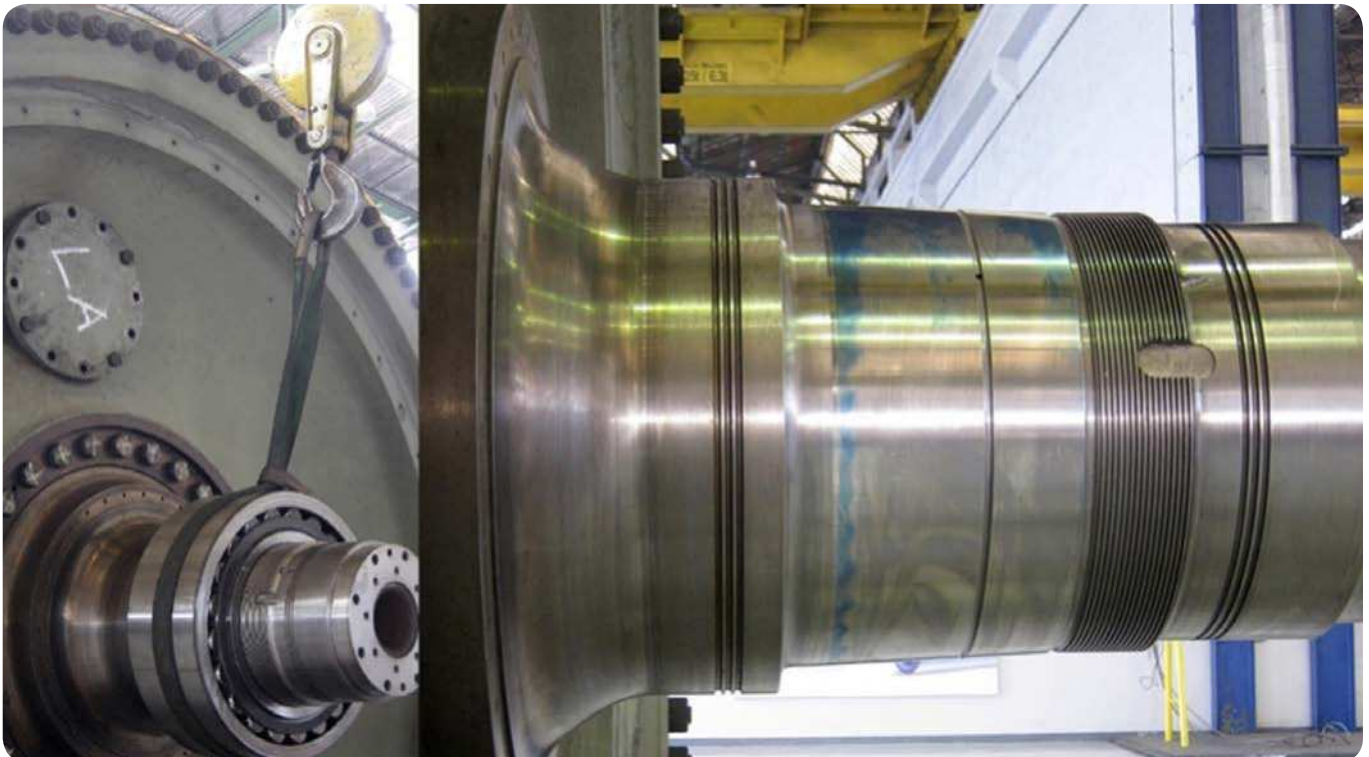

I quickly discarded the idea of torque on a nut as it is not accurate enough. The possibility for variation depending on friction in the threads and between the nut and the bearing inner ring plus thread cleanliness and condition is too great. Also, as you don't use a simple torque wrench on a 500 mm or larger nut anyway, I decided to forget it.

I then undertook some research in the archives as this is a similar issue to the one to determine the position before axial drive-up using the axial drive-up figures quoted in the bearing catalogues. The SKF catalogue *Rolling bearings* clearly states that the drive-up data tables are to be used as a guideline only as it is difficult to establish the exact starting position. I drew a blank with my research.

Note that the SKF Drive-up method gives a starting position with some clearance reduction. This is not the same starting position for axial drive-up values quoted in the SKF catalogue *Rolling bearings* in which there is no clearance reduction, just the position before clearance reduction. As such, using the oil pressure injected in a hydraulic nut from the SKF Drive-up method is not suitable for

Prussian blue checking. Neither is it difficult to determine starting position from the old method because the bearing has already deformed to take the shaft form and we don't want this to happen in a Prussian blue check. For a short recap about the different positions, see **table 1**.

The question is how much pressure is needed in the hydraulic nut to hold the bearing in position with circumferential contact, but without forcing it to take the form of its seat. As the Prussian blue check would be correct if the shaft was vertical and the bearing was resting on its own weight, I calculated the pressure necessary to push a bearing with an axial load equal to its weight, to offset the axial load due to the taper angle pushing the bearing down the tapered journal and to overcome the friction between the bearing and the journal.

Table 1

Definitions of bearing positions as stated in this article

- a Bearing position for Prussian blue checking**
The bearing should rest on the journal just like if it was resting on the journal in a vertical position. With its axis in the vertical position, the bearing rings will not deform under their own weight and will be concentric with the journal. In theory, the bearing should just touch the journal as if the bearing bore and shaft tapered seat are perfect tapers with the same angle and 100% of the surfaces will be in contact. Any further displacement of the bearing, due to its own weight for example, could force the bearing to start to take the shaft form if it is not a perfect taper. In practice, due to manufacturing tolerances, a slight further displacement should be accepted, but to what value?
- b Starting position in the axial drive-up method**
The position just before the bearing inner ring expands radially.
- c Starting position in the SKF Drive-up method**
The position in which the bearing inner ring has already radially expanded with a radial clearance reduction of 0,00009 times the bearing bore diameter.

Note that the distance between position **a** and **b** or **a** and **c** depend on the real form of the bearing bore and the tapered seat on the journal.

I knew that the pressure values would be smaller than the ones used to find the starting position, but they are smaller than I expected:

- 0,03 MPa for a 22320 which is a 13,5 kg bearing
- 0,08 MPa for a 23176 which is a 230 kg bearing
- 0,30 MPa for a 241/900 which is a 3 350 kg bearing

An issue is that the pressure gauges used for the SKF Oil Injection and SKF Drive-up methods are not very precise at such small values as 0.03 MPa (the SKF THGD 100 digital gauge, for instance, is rated at $\pm 0,1$ MPa) and that suitable gauges could not withstand the pressures that the pumps used could deliver.

Next, I tried the hands on approach with a 22320 EK bearing. First, I slammed the bearing on to its tapered seat and used a micrometer set to zero as the reference (\rightarrow figure 2). This is the right position for the Prussian blue method for a bearing of this size and it can easily be removed by hand. Then I positioned the bearing with the nut and hammer plus sound method (\rightarrow figure 3). The bearing was driven-up further and needed to be gently hammered to dismount it, but the distance was less than 0,08 mm even after three attempts. Finally, a hydraulic nut was used to position the bearing (\rightarrow figure 4). The idea was to measure the oil pressure when the bearing was in the slam position and then again in the sound position and to note the position of the bearing with the calculated pressure.

The result with the hydraulic nut was that the pressure needed was higher than the calculated pressure even before the bearing reached the slam position. The main reason, which I hadn't accounted for, was the friction of the hydraulic nut piston seals.

I also found that the pressure is nearly constant before and while passing the slam position and while passing the sound position. The pressure increases quickly as the bearing inner rings starts to take the shape of the journal after reaching a position around 0,2–0,3 mm beyond the slam position. The SKF Drive-up method starting position with 4,1 MPa is never reached in the range of the micrometer.

An additional finding was that the curve pressure/position is not consistent. The test has poor repeatability. Pressure variation was more than 50% of the calculated pressure.

The conclusion, in my opinion, is that the sound method is more reliable than the hydraulic nut method. I do not think that it is worth continuing with and trying to know the range of pressure in which seat form errors are still apparent. There are too many considerations to take account of. As such, if a less subjective method is needed, then I think a 3D inspection with a portable coordinate measuring device is the way to do it.

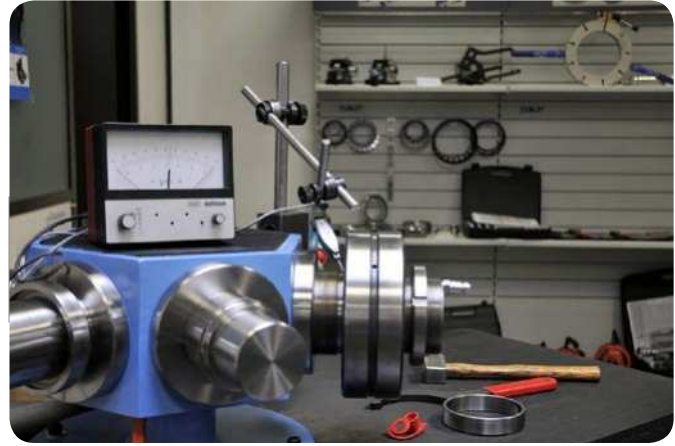

Fig. 2 Bearing position after being slammed into place

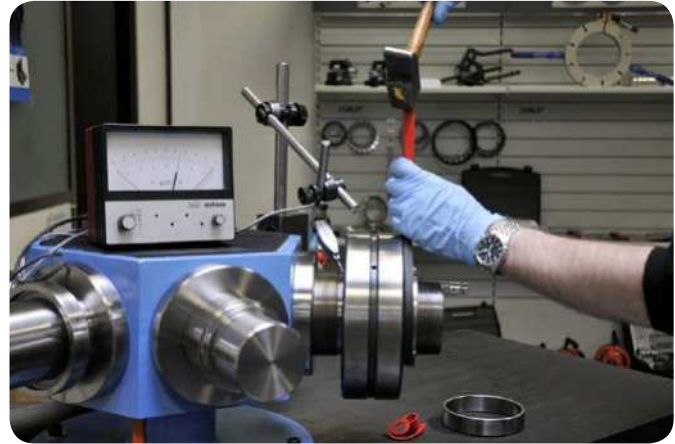

Fig. 3 Bearing position with the nut and hammer plus sound method once the sound becomes more metallic

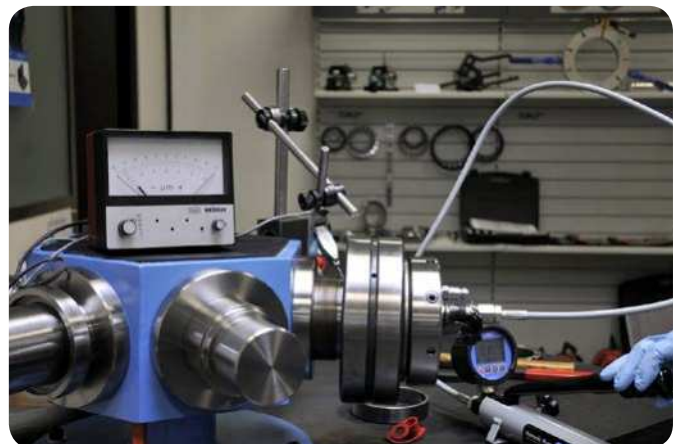

Fig. 4 Final test with a hydraulic nut

2. The number of diameter measurements needed to check ovality

Joe B Conyers from SKF USA sent an email after reading *SKF Pulp & Paper Practices 13* to tell me that taking three measurements around the journal was not enough to check circularity, but four measurements should be enough.

Joe was right. Regardless of what sometimes happens in the field, four measurements should be the minimum to be considered good practice (→ **figure 5**).

While taking more measurements does lead to a clearer picture of form errors, a balance needs to be struck between accuracy and practicality. While thinking about this I wondered how many bearing and machine issues were due to form errors that were not discovered during measuring. I checked our archives and did not find a single case. This, of course, does not mean that they don't exist.

My time spent in the archives was useful though as I spotted a number of things. I saw that most reports had four diameter measurements, but some had only three. I also noted that in some reports the diameter values were close to the maximum of the tolerances, in or out. It was a pity that the type and precision class of the tools used was not indicated though.

Coming back to good practice, I think that the direction of the load should be indicated and documented as bearing seat circularity can increase or decrease the load on the most heavily loaded rolling element and therefore affect bearing fatigue life. So, having a bearing seat cylindricity/circularity that is out of tolerance is not always bad.

In cases where the direction of the load is fixed relative to the bearing seat, at least one measurement should be taken in the load direction.

Table 2 shows an example of a measuring report form for a cylindrical bearing seat. Note that it is designed for one bearing seat only, so simply cross out the drawing that is not applicable. Note also that some industries like steel use bearings with four rows of rolling elements and measurements can be taken in more than just two radial planes.

Table 3 is an example of a measuring report when using the SKF 9205 taper gauge.

3. T_m values for high precision radial run out bearings

After publishing *SKF Pulp & Paper Practices 14*, I was asked about the T_m values for bearings with C08, VQ424 and VA460 suffixes i.e. bearings with reduced radial run out tolerances. The reason was that the values listed in **table 1** in that issue state that they are for normal precision SKF bearings only.

The answer is that the bore of such bearings are manufactured to the normal precision shown in the SKF catalogue *Rolling bearings* unless indicated otherwise by an additional suffix. As such, in most cases, simply use the values shown in *SKF Pulp & Paper Practices 14*.

Fig. 5 Increasing the number of diameter measurements increases the possibility to get measurements close to the minimum and maximum diameter

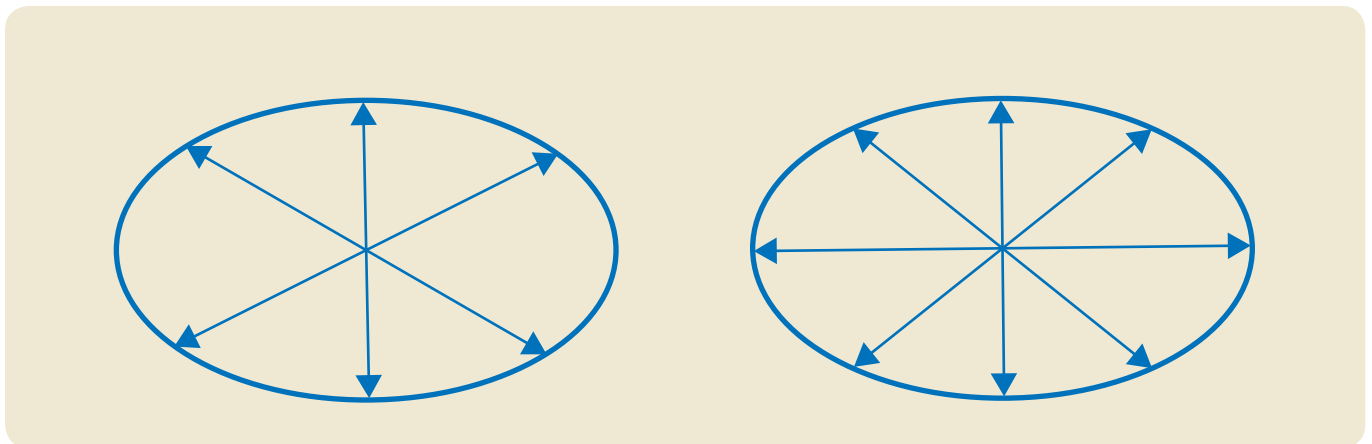

Machine	
Application and position	
Bearing designation	
Measuring tool type	
Precision class or accuracy	
Zero setting standard bar	Type:
Last standard bar control	Date:

Draw on drawing direction of load

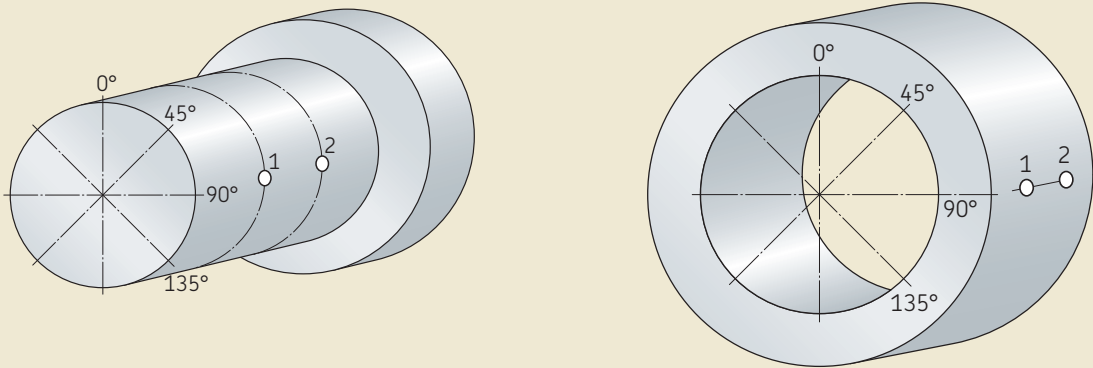

Nominal diameter:	mm:		Tolerance on diameter:			
			Tolerance on cylindricity:			
All values in mm	0	45°	90°	135°	Deviation	Total deviation
Plane 1						
Plane 2						

Comments on straightness :

Comments:

Date:

Name:

Table 2 Measuring form report for a cylindrical seat

Machine	
Application and position	
Bearing designation	
Measuring tool type	
Precision class or accuracy	
Zero setting standard bar	Type:
Last standard bar control	Date:

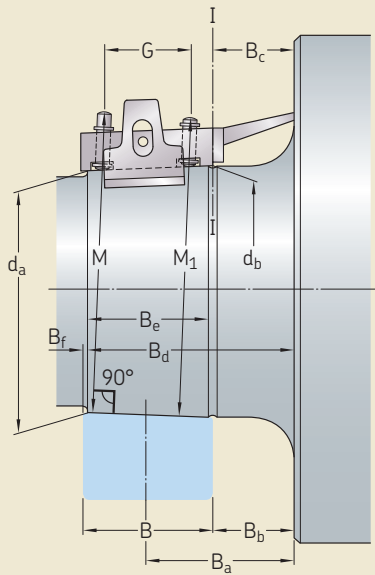

B =
 B_c =
 B_e =
 B_a =
 B_f =
 G =

 SKF Gauge 9205... -

 B_d =
 d_a =
 d_b =
 M = +/-
 Circularity =
 M₁-M =

 If adjusted spacer
 B_b =
 B_n =

All values in mm	0	45°	90°	135°	Deviation	ΔM
M						
M ₁						
M ₁ -M						

If adjusted spacer: B_{be} =

Comments on straightness :

Comments:

Date:

Name:

Table 3 Measuring report form for a tapered seat checked with the SKF 9205 tool

4. Bearing failure pie charts

I remember a presentation to a group of customers from different French paper mills and being questioned about failure causes. I had told them that 25% of bearings fail due to inadequate lubrication. They queried this. One told me that he was always led to believe that 43% fail due to this cause. Another consulted the SKF Maintenance products catalogue and said 36% is written here.

In fact, all the figures are correct, but we need to understand how they have been estimated and to know that they are for industries and applications in general. This leads to a situation where the main bearing failure cause, in general, is lubrication whereas we know that the main cause in paper machines is water ingress.

The 43% comes from an SKF France estimation based on bearing failure analysis for all industries (→ **diagram 1**). SKF Sweden came up with different estimates and the 36% comes from them (→ **diagram 2**). SKF USA had different estimates (→ **diagram 3**). As did other SKF countries. For consistency in SKF documents, it was decided to use the Swedish estimate.

The differences between the estimates, in my opinion, are due to the following reasons:

- 1 The types of industries present in the countries.
- 2 How the local SKF engineer classes the bearing failure.
- 3 Simplification of the pie charts to show only the main causes
- 4 Culture, experience etc.

Bearing failure analysis, for instance, is not as simple as it might sound. For example, water ingress in the lubricant leads to inadequate lubrication, but if there is no sign of corrosion and if there is incomplete information, the failure cause could be noted as inadequate lubrication.

The 25% from my presentation was derived from the main bearing failure cause in paper machines and based on discussions between mill maintenance people and SKF engineers (→ **diagram 4**). As I was presenting to a European audience, I used the European figures. For a group from the USA and Brazil, the figures would have been different (→ **diagram 5**). Nevertheless, water ingress would still be the main failure cause.

For paper or tissue machines, it is possible to examine applications in more detail (→ **diagram 6**). You will note that no percentages are indicated. This is done on purpose as I believe that estimates based on known cases do not reflect reality with sufficient precision.

SKF has not created estimates for all the bearing applications in all the different types of mill and, to be frank, I'm a little reluctant to do such a study. Not because it is time-consuming, but because I prefer that the analysis is done on the mill level to facilitate specific corrective actions. Sometimes this can lead to big surprises as the following story shows.

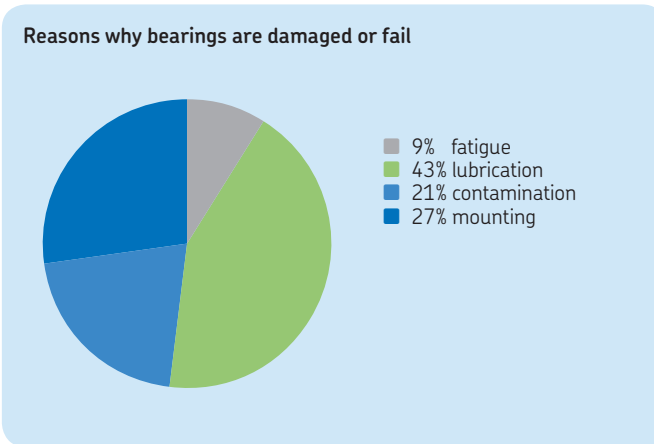

Diagram 1 SKF France's estimation of damage or failure causes for all industries

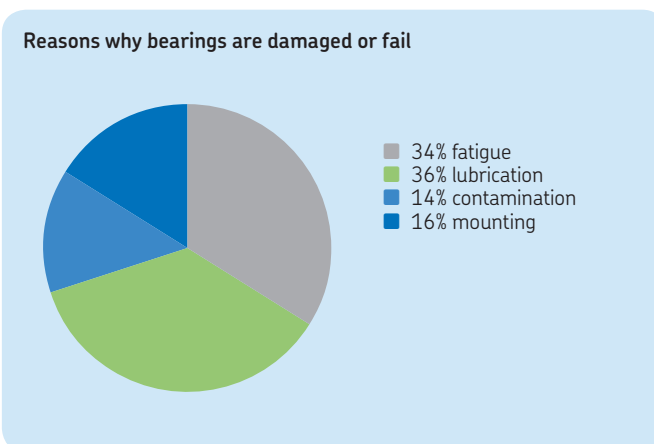

Diagram 2 SKF Sweden's estimation of damage or failure causes for all industries

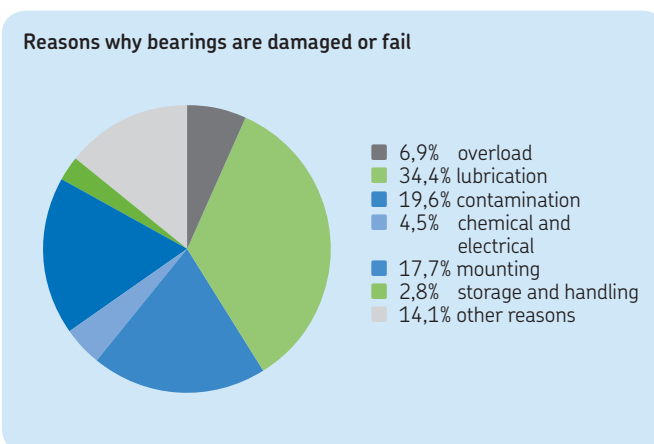

Diagram 3 SKF USA's estimation of damage of failure causes for all industries

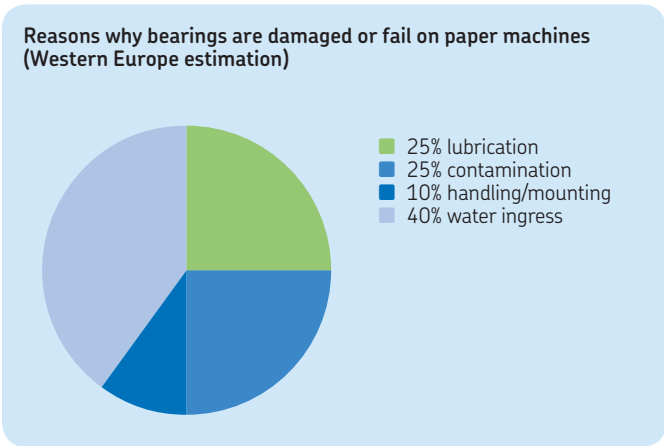

Diagram 4 The main causes of bearing damage or failures in paper machines in Western Europe

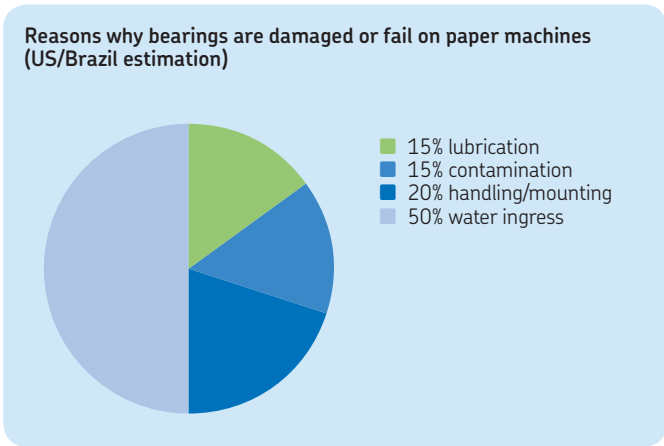

Diagram 5 The main causes of bearing damage or failures in paper machines in the USA and Brazil

A good SKF customer was sending us bearings for failure analysis perhaps once or twice a year. Over the years, a picture built up showing that the main causes were lubrication and water ingress.

An Integrated Maintenance Solutions (IMS) contract was later signed with the mill. To reduce their bearing consumption, we agreed that all dismantled bearings would be stored with some paperwork indicating the bearing application, position and the reason for dismantling them. Every quarter I would travel to the mill to examine the bearings together with some of the mill's operations and maintenance people. The idea was that this would be a form of training for them.

We didn't undertake detailed failure analysis on all the bearings. We reserved that for the critical ones. Nevertheless, we did examine all the bearings. Most of them would never have been sent to SKF for failure analysis as they weren't in a critical application or they were comparatively cheap or they were not the cause of unplanned stops. Normally, they would have just been scrapped.

After a few visits to the mill, it quickly became apparent that most bearings were failing due to solid contamination rather than water ingress or inadequate lubrication.

What should we learn from this story? That bearing failure cause pie charts are based on reports and statistics compiled by manufacturers from failures that they have seen. Also that measuring and creating pie charts is one thing, but that selecting the right and most appropriate corrective actions is what really counts.

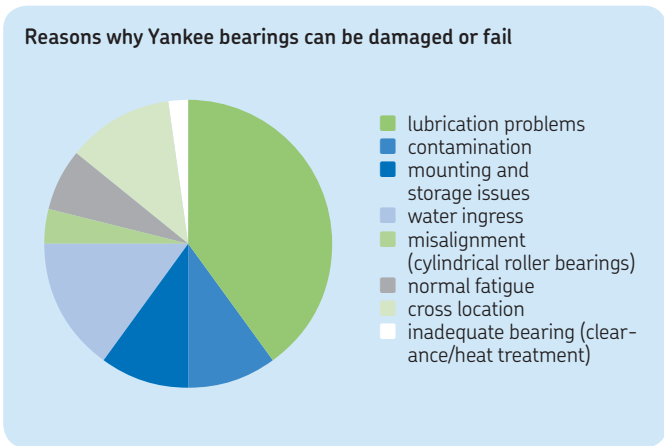

Diagram 6 The main causes of Yankee bearing damage or failures

Regards,
Philippe Gachet
Senior technical consultant
Philippe.gachet@skf.com



The Power of Knowledge Engineering

Combining products, people, and application-specific knowledge, SKF delivers innovative solutions to equipment manufacturers and production facilities in every major industry worldwide. Having expertise in multiple competence areas supports SKF Life Cycle Management, a proven approach to improving equipment reliability, optimizing operational and energy efficiency and reducing total cost of ownership.

These competence areas include bearings and units, seals, lubrication systems, mechatronics, and a wide range of services, from 3-D computer modelling to cloud-based condition monitoring and asset management services.

SKF's global footprint provides SKF customers with uniform quality standards and worldwide product availability. Our local presence provides direct access to the experience, knowledge and ingenuity of SKF people.

SKF Global Pulp & Paper
Segment

Contact/Responsible editor
philippe.gachet@skf.com

© SKF is a registered trademarks of the SKF Group.

© SKF Group 2015

The contents of this publication are the copyright of the publisher and may not be reproduced (even extracts) unless prior written permission is granted. Every care has been taken to ensure the accuracy of the information contained in this publication but no liability can be accepted for any loss or damage whether direct, indirect or consequential arising out of the use of the information contained herein.

PUB 72/S9 11147/14 EN · September 2015





Fretting corrosion on the outside surface of a bearing outer ring due to a damaged raceway

“What’s the correct fit for this bearing?”

This is a question that any SKF application engineer is frequently asked. The answer is rarely straightforward, but it’s important to get it right.

From the bearing point of view, applications in the pulp and paper industry may be subject to demanding operating conditions, such as large temperature gradients, heavy loads, hollow journals, rotating outer rings, etc. In these cases, special attention should be paid to dimensional and geometrical tolerances of adjacent components, mainly to avoid costly unplanned stops.

SKF has acknowledged the influence of shaft and housing geometry on bearing performance for decades. By means of intensive

research, analytical calculations, custom software and continuous interaction with OEMs and end users, we have gathered more than enough information to help you tackle any problem regarding this particular aspect.

In this issue of SKF Pulp & Paper Practices, we are going to go through some phenomena which occur on bearing seats due to incorrect tolerances and fits. Wear, fretting corrosion and creep appear very often—too often in my experience with paper mills and root cause failure analysis—and are sometimes considered unavoidable. Not only do they definitively shorten bearing life, they may also cause them to fail catastrophically.

I hope these documents help you understand more about rolling bearings, improve

procedures and applications and, eventually, increase the reliability of your rotating machinery. Whatever question you may have, please don’t hesitate to contact SKF!

Regards,
Franco Gagliano
Application Engineer
SKF Argentina S.A.



Fretting corrosion and wear in the bearing seat due to ring creep or micro movement

I have seen many damaged bearing seats in my time. Sometimes only the bore or the outside diameter of the bearing has fretting corrosion and/or wear, but mostly the bearing has internal damage. While this can be partly explained by customers only contacting SKF when they have a serious problem, my experience is that minor seat damage is common even when the bearings are in good condition. This can have a bigger impact on bearing life than many people think. The outer ring movement of the non-locating bearing on its seat can be hampered thereby increasing axial load, for example.

While undertaking root cause failure analysis in mills, I've seen many bearings in poor condition which have rotated on the shaft or in the housing. This can lead to heavy wear and high costs to repair or replace shafts or housings. Often, the finger of blame is pointed at the bearing but, in reality, it's not the cause.

Bearing ring creep on the seat or heavy fretting corrosion can be the root cause of bearing damage, but it can also be secondary damage. While I cannot say what the ratio between the two is, I can show you many cases where the fit was the root cause of the problem.

In this issue of SKF Pulp & Paper Practices, I will cover the reason why a bearing ring creeps on its seat, the cause of fretting corrosion and the impact on bearing life. There will be no formulas and no equations, just information to help the reader understand the phenomena.

What is fretting corrosion?

That rotation or creeping of a ring on its shaft seat or in the housing bore seats creates wear and perhaps smearing is readily understandable, but I'm sometimes asked about the cause of fretting corrosion.

Fretting corrosion occurs when there is relative movement between a bearing ring and its seat on a shaft or in the housing. This relative movement can be very small and occur due to the unique elastic deformation of the rings under load, for example (→ figure 1).

The relative movement may cause small particles of material to become detached from the bearing surface and its seat. They oxidize quickly when exposed to air and form iron oxide which is larger in volume than iron or steel. Therefore, and as a result of the fretting corrosion, the bearing may not be evenly supported. This can have a detrimental effect on the load distribution in the bear-

ing. Iron oxide particles will also act as abrasive particles increasing the wear rate and loosening the fit. In addition, the coefficient of friction increases in the mating surfaces and corroded areas also act as fracture notches.

Fretting corrosion appears as areas of rust on the outside surface of the outer ring (→ figure 1) or in the bore of the inner ring. The raceway path pattern could be heavily marked at corresponding positions. In some cases, fretting corrosion can be actually secondary damage due to heavy spalling on the raceway.

Depending on the chemical reaction, corrosion could appear as:

- red (hematite, Fe_2O_3)
- black (magnetite, Fe_3O_4)

Fretting corrosion damages not only the bearing outer surfaces, but also the bearing



Fig. 1 Fretting corrosion on the outer diameter of a spherical roller bearing

seats on the journal or in the housing. A new bearing mounted on damaged seats due to heavy fretting corrosion will probably have its service life decreased. This is especially true when the bearing has to displace axially to cope with thermal elongation of the shaft. Fretting corrosion increases the friction between the bearing and its seat and thus increases residual axial load on the bearing.

Why is a tight fit necessary?

First, let's look at → **figure 2** which shows a bearing mounted with a loose fit on the shaft. The bearing inner ring is rotating with the shaft and the load on it has a fixed direction i.e. from top to bottom. The contact between the inner ring and the shaft will always be on the top surface of the shaft, but the shaft and inner ring experience rotating load.

With a loose fit and the different circumferences of the mating surfaces, there will be a permanent creeping movement comparable to that found in epicyclical gears.

If the radial clearance Δ of the loose fit is equal to 0.010 mm, the creeping distance is equal to $0,01 \pi = 0,0314$ mm at each revolution. If the rotational speed is 3 000 r/min, the distance after one hour would be 5 654 mm.

The creeping movement, of course, occurs between the inner ring face and the shaft shoulder. The reality is that there isn't just creeping, there's also sliding that creates wear and increases the problem.

Selecting the proper fit where there is a fully constant rotating load and the shaft and inner ring like in the case above is relatively straightforward and errors are quite rare. In cases where the load changes direction, there isn't constant rotation or the ring oscillates on or in its seat, fit selection errors are common. While this can have minor consequences and be acceptable in some applications, it can have serious consequences as you'll see in the following examples.

The first example is the wheel bearing stub axle on a four-wheel drive car (→ **figure 3**). The two tapered roller bearings experience outer ring rotation and are mounted with a press fit in the hub. The bearings inner rings are mounted with quite a small loose fit, like a g6, chosen for easy mounting/dismounting and bearing clearance adjustment. Load on the inner rings oscillates around the vertical line depending on torque due to acceleration, speed, braking

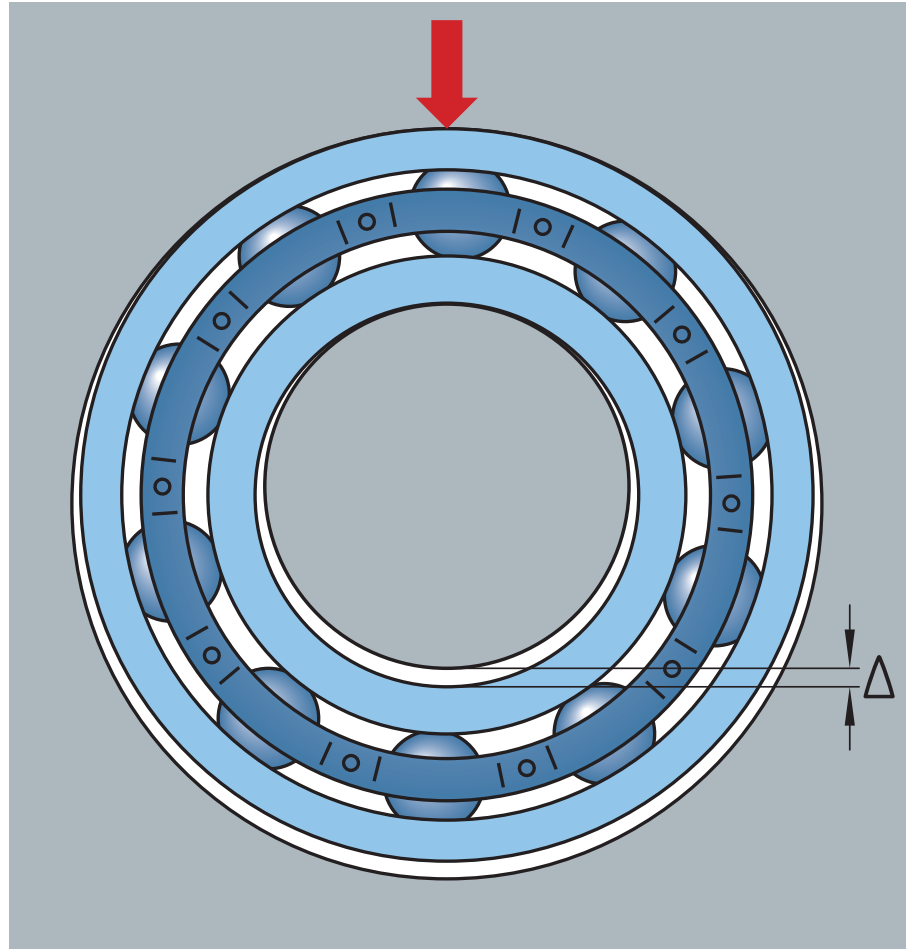

Fig. 2 Bearing inner ring mounted on a rotating shaft while the load has a fixed direction

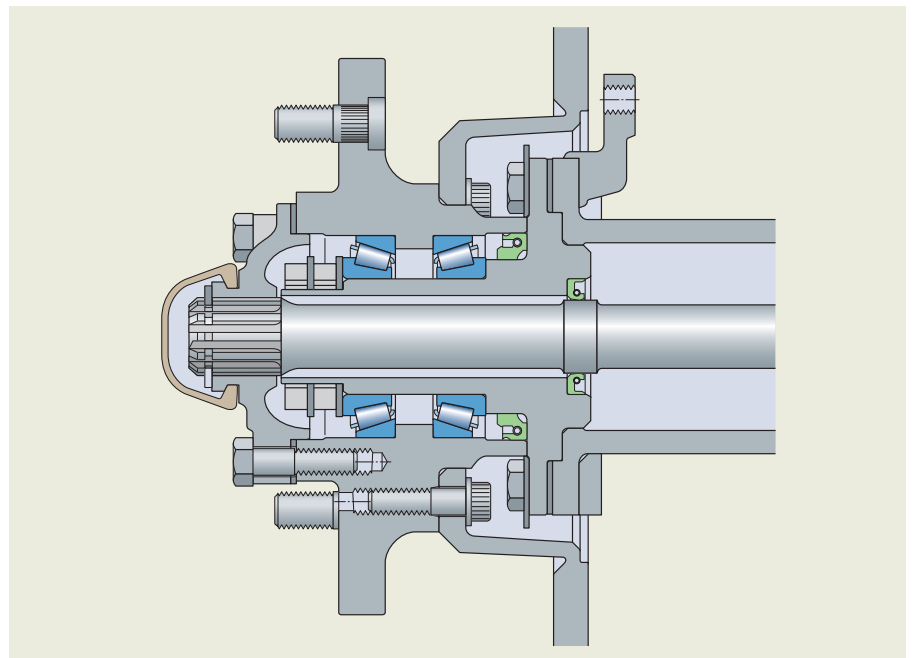

Fig. 3 Bearing assembly in a rear-driven wheel hub

etc. The inner rings roll back and forwards on the stub creating wear (→ **figure 4**).

Is this loose fit leading to acceptable wear? I would definitely say yes. After 200 000 km, there was just minor surface wear creating a mirror-like surface with some slight fretting corrosion. After 400 000 km, the wear could be felt with your fingernail, but it was not severe enough to make me decide to change the stub.

My second example is the intermediate gears used to drive groups of drying cylinders in some paper machines (→ **figures 5 and 6**). The typical bearing arrangement has two cross-located spherical roller bearings mounted with a tight fit on the inner rings and a loose fit on the outer rings. The outer rings are mounted like this to facilitate mounting and dismounting, for cost reasons, and to allow the bearings to find their position in operation. I've got a case in which there was on one side a double row tapered roller bearing and on the other side a cylindrical roller bearing, with tight fit for the inner rings and loose fit for the outer rings.

Depending on the radial run out of the drying cylinders, the felt tension and so on, the drying cylinders can be partly or fully driven by the paper and felt for short periods. When this happens, the load on the gears is modified and can sometimes even change direction. Load variation and load direction variation on the gear teeth when the gears drive or are driven make the bearings move in their housings creating heavy wear (→ **figures 7 and 8**).



Fig. 4 Wheel bearing stub axle showing wear in the contact surface with the tapered roller bearings due to a loose fit and changing load direction after 200 000 km

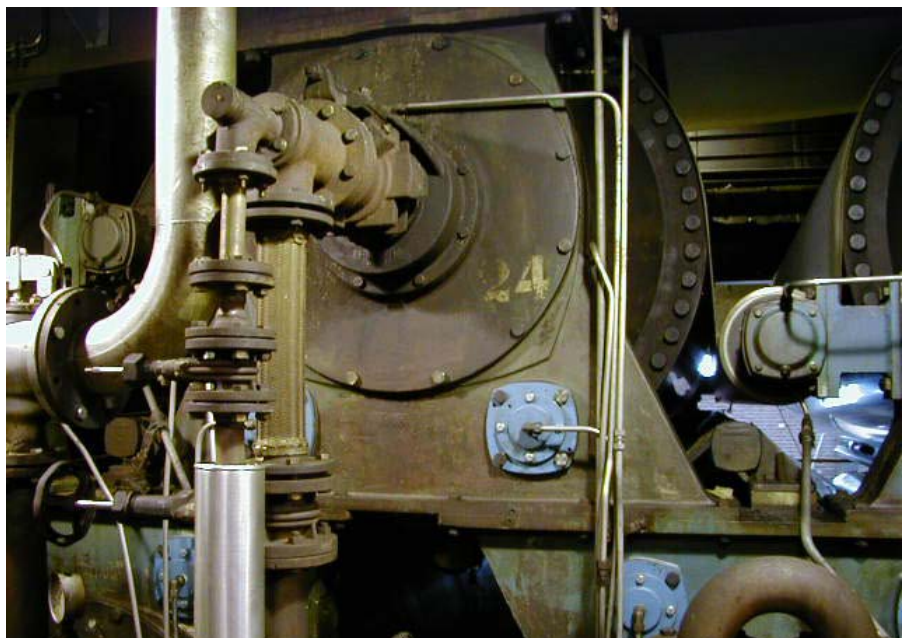

Fig. 5 Intermediate gears on a drying cylinder drive. Note that the blue covers show their position

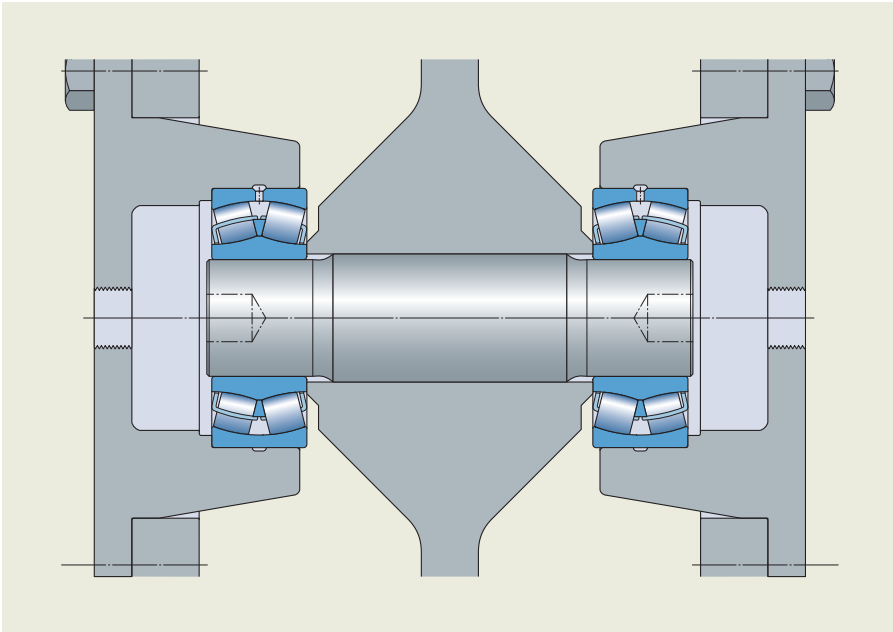

Fig. 6 Typical bearing arrangement for intermediate gears in the dryer section



Fig. 7 Fretting corrosion in the housing



Fig. 8 Fretting corrosion on the bearing outer diameter

While fretting corrosion creates particles that can contaminate the bearing, it can also lead to ring fractures as corroded areas act as fracture notches. Wear accelerates where helical gears are used and the loose fit can increase to such an extent that it is too great for tapered roller bearings and cylindrical roller bearings to tolerate as they cannot accept much misalignment.

In all cases, the bearing life is reduced and the housings need replacing. As do the gears which no longer mesh together properly. In my example, the wear rate was more or less the same in all positions so there were no issues until many years after the machine was built. However, when the problems started, the bearing failures and gear problems all happened over the course of a few years and led to a series of machine stops lasting 12–48 hours per position.

As a solution, SKF proposed an arrangement in which all the bearings are mounted with a tight fit in the housing and on the shaft. This meant that a cylindrical roller bearing could be used if a suitable CARB toroidal roller bearing wasn't available (→ figures 9 and 10)

Some customers asked SKF to modify their arrangements accordingly, but most decided to upgrade to “silent drive” i.e. removing the gears and having their drying cylinders driven by the felt rolls. This, however, created new bearing issues that I will cover later on.

While the issue of load direction changes in gears is well known and loose fits in the housing are avoided wherever possible (often H7 \oplus is used), too small loose fits can be problematic. We've seen this in gearboxes and in drying cylinders in the past too.

If non-locating bearings in gearboxes have to displace in their housings, they are often mounted with a H7 \oplus fit. Why is that fit chosen? Well, in theory, it's to provide a loose fit that allows for good gear meshing while reducing wear in the housing. However, quick start ups from cold with high viscosity oils can lead to the bearing heating up very quickly. This can lead to problems. Not only can the bearing inner ring heat up faster than the shaft and lose its tight fit, but the outer ring can heat up faster than the casing and the loose fit becomes a tight one. In such cases, no more axial displacement of the non-locating ring is possible and the bearing can fail due to excessive axial load.

With drying cylinder bearings the risk where spherical roller bearings were/are mounted as the non-locating bearing is that

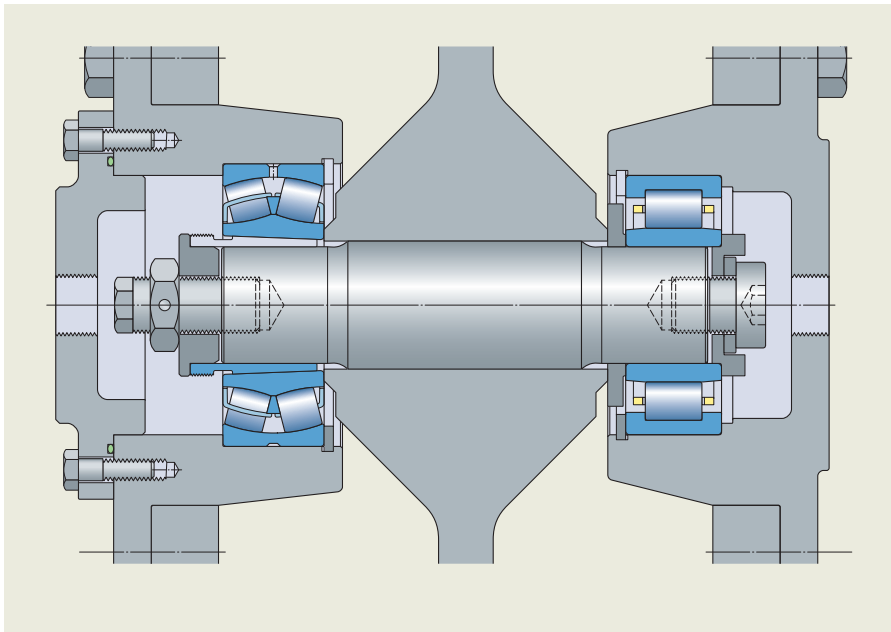

Fig. 9 SKF proposal with one spherical roller bearing and one cylindrical roller bearing

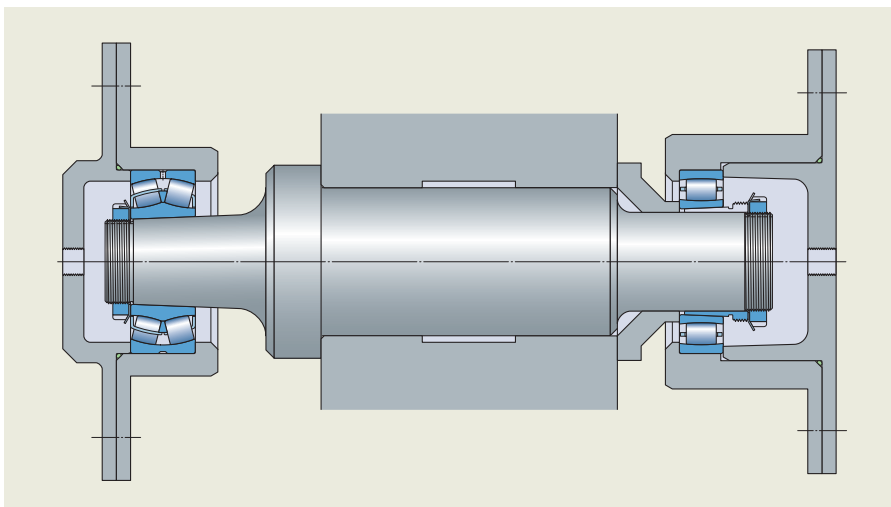

Fig. 10 SKF proposal with one spherical roller bearing and one CARB toroidal roller bearing

the outer ring can expand faster than the housing during start up and what are supposed to be non-locating bearings become locating ones. In such cases, F7 \oplus tolerance instead of G7 \oplus is recommended.

Tight fits do not always stop relative movement

Surprisingly for many, a ring mounted with a tight fit on the shaft can still creep under certain conditions. In fact, load on a bearing creates bearing, shaft and housing deformation.

Let's look at what happens when a bearing inner ring is mounted with a tight fit on a shaft. The load pushes the rollers into the rings and the rings deform. The bearing ring elongates so that the circumference of its bore gets larger. This explains why a tight fit can become a loose fit under load allowing a ring to creep on the shaft.

Even if the tight fit is sufficient to stop the ring creeping under load, the issue has not disappeared. There is still the possibility of micro movement between the ring and the shaft. This can happen if the ring is thin and the load is very high. Localized sliding may

then occur in the vicinity of the rolling element contacts between the ring and shaft that will create fretting corrosion without creeping.

It's worth noting that the race to have the highest catalogue ISO load capacity has led some bearing manufacturers to increase the diameter of their rollers as this is one factor in the calculation of the dynamic load rating value. The danger is that too large rollers means too thin rings resulting in an increased risk of fretting corrosion and loss of tight fit under high load. Keep in mind that while there is an ISO norm to calculate the dynamic load rating, bearing manufacturers are free to set the steel performance factor value for the calculation and there is no ISO procedure to check that claimed values are based on facts rather than marketing.

Let's look at an example of the loss of tight fit under load using a silent drive case. It concerned a Beloit machine built in 1974 with drying cylinder gear drives and grease-lubricated felt roll bearings mounted on adapter sleeves in the dryer section. In the 1990s, the mill decided to upgrade the dryer section to silent drive and to have the felt roll bearings lubricated by a circulating oil system.

A few years later, felt roll bearings started to fail (→ **figure 11**) while others exhibited heavy fretting corrosion in the bore, the sleeve bore and on the shaft (→ **figure 12**).

Analysis of the bearings, sleeves and shafts indicated that the fit wasn't tight enough for the application. The failed bearings would, in fact, have been heavily preloaded and inadequately lubricated as the result of significant sliding of adapter sleeves on shafts leading to high friction and inner rings heating up.

This wasn't easy to explain to the mill since experienced fitters had been mounting the same bearings in the same way for more than 20 years. The simple fact is that the feeler gauge mounting method and clearance reduction value used were fine for the load applied on the bearings prior to the upgrade to silent drive. This wasn't the case after the upgrade as increased felt tension increased the load on the bearings and the clearance reduction was no longer sufficient to give tight enough fits.

Look at the SKF's *Rolling bearings* catalogue where you'll see that the higher the load, the tighter the recommended fit. Furthermore, over the years load capacities (basic dynamic load ratings) have increased. For the same calculated basic rating life, the



Fig. 11 Part of a bearing inner ring on an adapter sleeve following heavy damage



Fig. 12 Heavy fretting corrosion in an adapter sleeve bore, but the bearing raceway is in quite good condition which gives a clue about the root cause

load is increased by the same value as the basic dynamic load capacity and new recommendations for fits had to be given. Using the example of a 22316 E felt roll bearing operating under “normal load”, m6 was recommended in 1990, but n6[Ⓔ] is recommended today. For the same bearing under “heavy load”, SKF now recommends p6[Ⓔ]. Note that with tighter fits, higher radial clearance classes may be needed.

There is another example in paper machines where deformation leads to the demand for tighter fits than normal to avoid micro movement between the bearing inner ring and the journal. In some cases, they cannot be avoided even with very tight fits and often lead to bearing seat damage (fretting corrosion, wear and smearing) and short bearing service lives.

The application I’m talking about is suction rolls of similar design to the one shown in → **figure 13**. The bearing is mounted on a shaft with a bore diameter close to 80% or more of the bearing bore diameter. Under load, especially in the case of suction press rolls, the shaft ovalizes as does the bearing inner ring. Consequently, the diameter of the shaft and bearing inner ring varies during rotation creating micro movements between the shaft and the ring.

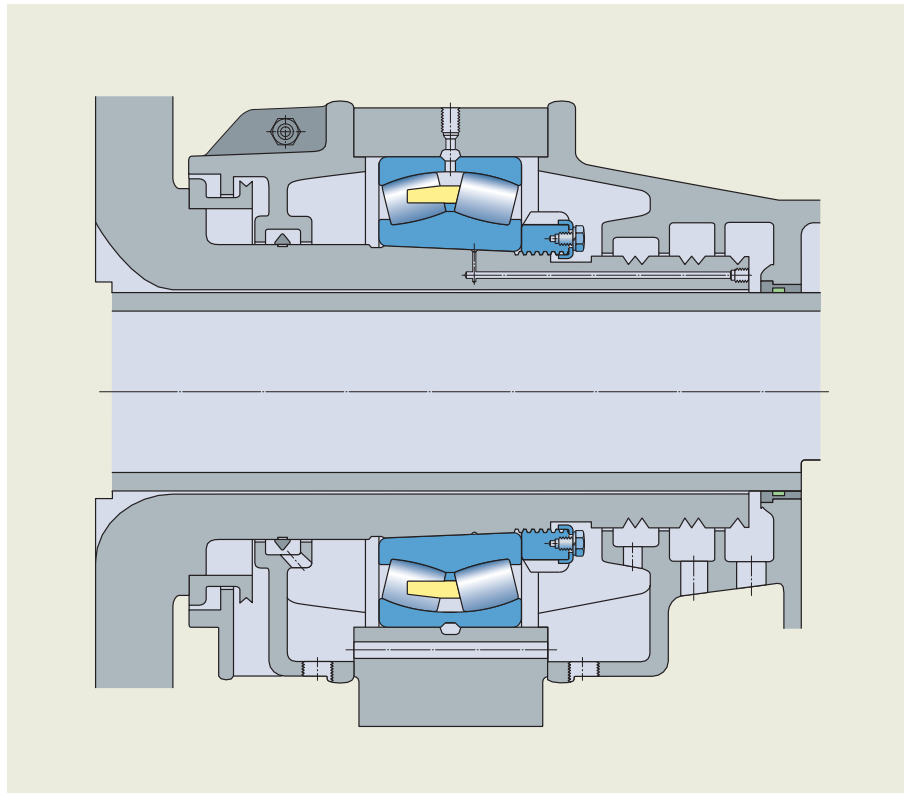

Fig. 13 Spherical roller bearing mounted on a very large bore shaft

When a bearing's bore diameter is close to 80% of the outer diameter of the shaft, the clearance reduction should be 0,00065 of the bearing bore diameter rather than the 0,0005 that is normally recommended. For example, the clearance reduction for a 230/600 CAK/W33 bearing (600 mm bore diameter) is $600 \times 0,00065 = 0,390$ mm. Due to the tighter fit, a higher radial clearance class than would normally be recommended for the operating conditions should be used. If a 230/600 CAK/W33 was initially selected based on the speed, load and operating temperature, a 230/600 CAK/C3W33 should actually be used.

Once you get above the 80–82% range, and depending on the shaft material, you are faced with micro movement and/or creeping regardless of the tightness of the fit. Increasing the tight fit and mounting case hardened bearings is pointless and experience has shown that glue doesn't help either.

A tight fit can be lost or reduced for other reasons such as the bearing heating up much more quickly than its shaft. This can happen with bearings with integrated friction seals running at high speed, when there is excessive lubrication or if the lubricant is too high viscosity. It can also happen if the shaft bends under the ring (→ figure 15).

The influence of tight fits on bearing life

Several things need to be taken into account. That tight fits reduce bearing clearance or increase preload. Also that tight fits on the inner ring increase hoop stress and reduce fatigue life.

There is a balance to be struck between fits and fatigue life. Fits should not be tighter than necessary because this reduces bearing life and could potentially lead to ring cracking (→ figure 16). Consider drying cylinder bearings. They are mounted on shafts that expand more quickly than their inner rings during start up due to steam temperature. During operation, the shaft is always hotter than the bearing which is the opposite of the situation found in most applications. The temperature gradient increases the tight fit. However, I would not recommend looser fits in an attempt to increase fatigue life since bearings can fail much earlier if they creep on their seats.

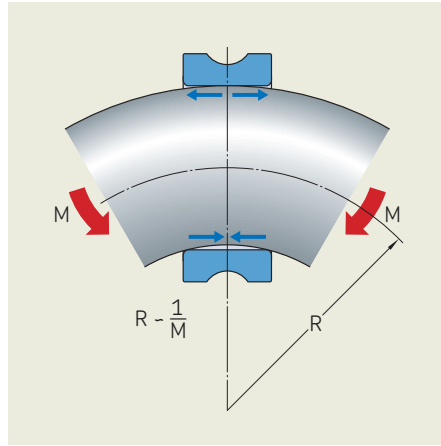

Fig. 15 Shaft bending under the bearing inner ring



Fig. 16 The fractured inner ring of a spherical roller bearing resulting from excessive drive-up

Loose fits are inadequate, but often necessary

Loose fits aren't adequate. I imagine that some people would disagree and argue that they have been used for decades on bearings that experience a fixed load direction. While it is certainly true that they are used, they are still inadequate. The main reason they are used is for ease of mounting/dismounting and to allow the non-locating bearing to move axially.

Our earlier wheel bearing and intermediate gear bearing examples showed that the desire for easy mounting can be acceptable, but also that it might not be. Looking for the easiest way can lead to unexpected fit selection errors. At the end of this issue, you will find something on a common error that occurs during maintenance on standard split plummer block housings.

It's the same for the desire for loose fits to accommodate displacement on non-locating bearings. Even if there is a stationary load of constant magnitude on a ring, fretting corrosion will occur if the fit is not tight enough. The speed at which the fretting appears and its intensity will depend on the load magnitude and the friction between the mating surfaces. Fretting corrosion will increase friction between the ring and its seat increasing the axial load caused by thermal elongation (→ page 6 of *SKF Pulp & Paper Practices issue 6*). This can be acceptable if the bearing does not suffer from the fretting corrosion and the increased friction between the mating surfaces or if the service life is limited by other causes. A non-locating sealed deep groove ball bearing in an electrical motor rarely fails due to very slight fretting corrosion, but it has been an issue for axially-free spherical roller bearings mounted in a housing fixed to the machine frame on drying cylinders. In this application, significant thermal elongation of the cylinder creates residual axial loads due to friction between the bearing and the housing and has a large effect on bearing life. Few mills still use such bearing arrangements as better options like CARB have long been available.

Fit selection

I won't go into details about how to select a fit since I believe that each case is a special case. The *SKF Rolling bearings* catalogue has guidelines, but thought needs to be given about whether they are followed or if they

should be adapted for the application in question.

Fit selection needs to balance several criteria and often involves compromises. You need to consider:

- Bearing rotation condition
- Load direction and magnitude
- Bearing internal clearance or preload
- Ring hoop stress limit (this depends on material and heat treatment)
- Temperature gradient conditions (especially during start up)
- Running accuracy requirements
- Design of shaft and housing and surrounding parts
- Ease of mounting and dismounting
- Displacement of the non-locating bearing
- Seal design: be careful about contacting seals creating friction and heat that makes components expand

The fact of the matter is that in some applications it can be harder to select the right fit that to size the bearing based on rating life requirements. In case of difficulties, I recommend contacting your local SKF application engineering department for help.

Conclusion

The best option is to have all bearing rings mounted with a tight fit and adjacent elements that do not deform under load or with temperature changes. Unfortunately, this isn't always possible for cost and mounting/dismounting practicality reasons.

If there is fretting corrosion, with or without creeping, between mating surfaces that supposedly have a tight fit and there is little or no bearing raceway surface damage then the fit is not tight enough.

We don't recommend mounting a bearing that has to displace axially in or on a seat for rings which have to slide to accommodate thermal elongation if there is fretting corrosion or wear no matter how slight.

To stop or slow fretting corrosion, a special anti-fretting paste (e.g. SKF LGAF 3E) or coating (e.g. SKF black oxide) can be applied. A special coating or surface hardening of the bearing seat can also help. As can lubrication. Grease can be forced into the mating surfaces via a direct supply duct and grooves. SKF can also supply spherical roller bearing designed for vibrating screens which have the option of a PTFE coating in the bore

to prevent fretting corrosion. Such bearings have a VA406 suffix or a VA408 one if coated.

To avoid a ring rotating due to a loose fit, the best option is a locating pin in the ring locating slot. Where the rotating load is sufficient to make the ring rotate, but small compared to the existing fixed radial load, one or two O-rings can be mounted in a groove in the seat (→ figure 17). One O-ring should be used for single row bearings or two for double row ones.

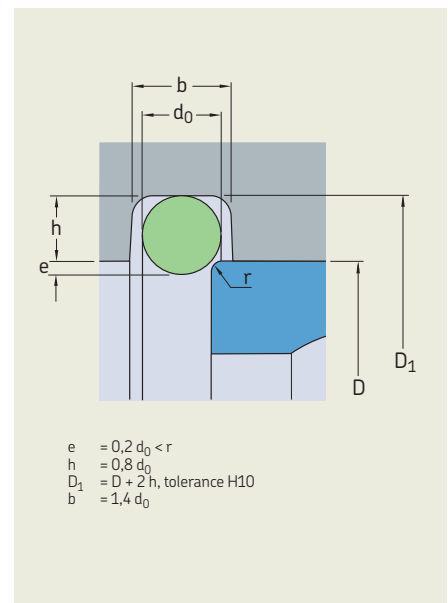

Fig. 17 O-ring in a bearing seat to reduce the risk of rotation in case of a loose fit

Regards,
Philippe Gachet
Senior technical consultant
SKF Pulp & Paper
global segment



Plummer block housing mounting error

As the cap and base of a split plummer block housing bearing seat are machined in the same operation, they should be kept together so that the dimensional and geometrical tolerances of the housing bore are met.

A common error is that caps and bases are exchanged during bearing mounting. → **Figure 18** shows a bearing outer ring where this has happened. The photograph shows part of the ring with fretting corrosion and thus contact, and one part without fretting corrosion and therefore no contact. On the opposite side of the ring, fretting corrosion is on the right and there's an undamaged surface on the left. When this happens, it creates oval clamping of the outer ring and can block the bearing creating axial overload in non-locating bearings that need to move in their housings and/or create premature fatigue.

To help prevent such problems, SKF SNL and SE housing have matching cap and base markings (→ **figure 19**). The markings are horizontal on SE housings and vertical on SNL ones. When mounting, care should be taken to ensure that the matching caps and bases are used.



Fig. 18 Oval clamping due to mismatched cap and base on a split plummer block housing



Fig. 19 Cap and base marking on a SKF SE Housing

The Power of Knowledge Engineering

Combining products, people, and application-specific knowledge, SKF delivers innovative solutions to equipment manufacturers and production facilities in every major industry worldwide. Having expertise in multiple competence areas supports SKF Life Cycle Management, a proven approach to improving equipment reliability, optimizing operational and energy efficiency and reducing total cost of ownership.

These competence areas include bearings and units, seals, lubrication systems, mechatronics, and a wide range of services, from 3-D computer

modelling to cloud-based condition monitoring and asset management services.

The SKF BeyondZero portfolio offers products and services with enhanced environmental performance characteristics.

SKF's global footprint provides SKF customers with uniform quality standards and worldwide product availability. Our local presence provides direct access to the experience, knowledge and ingenuity of SKF people.

skf.com

© SKF is a registered trademark of the SKF Group.

© SKF Group 2015

The contents of this publication are the copyright of the publisher and may not be reproduced (even extracts) unless prior written permission is granted. Every care has been taken to ensure the accuracy of the information contained in this publication but no liability can be accepted for any loss or damage whether direct, indirect or consequential arising out of the use of the information contained herein.

PUB 72/S9 11147/15 EN · December 2015

Certain image(s) used under license from Shutterstock.com.

The Power of Knowledge Engineering

Combining products, people, and application-specific knowledge, SKF delivers innovative solutions to equipment manufacturers and production facilities in every major industry worldwide. Having expertise in multiple competence areas supports SKF Life Cycle Management, a proven approach to improving equipment reliability, optimizing operational and energy efficiency and reducing total cost of ownership.

These competence areas include bearings and units, seals, lubrication systems, mechatronics, and a wide range of services, from 3-D computer

modelling to cloud-based condition monitoring and asset management services.

The SKF BeyondZero portfolio offers products and services with enhanced environmental performance characteristics.

SKF's global footprint provides SKF customers with uniform quality standards and worldwide product availability. Our local presence provides direct access to the experience, knowledge and ingenuity of SKF people.

skf.com

© SKF is a registered trademark of the SKF Group.

© SKF Group 2015

The contents of this publication are the copyright of the publisher and may not be reproduced (even extracts) unless prior written permission is granted. Every care has been taken to ensure the accuracy of the information contained in this publication but no liability can be accepted for any loss or damage whether direct, indirect or consequential arising out of the use of the information contained herein.

PUB 72/S9 11147 EN · December 2015

Certain image(s) used under license from Shutterstock.com.