

# High performance hydraulic piston seals

Overview and test results of MPV, DPV, LPV and CPV



# Reliable sealing solutions create value

Reduced leakage, reduced friction and an improved service lifetime. SKF's double acting piston seals are maintenance-free and deliver top quality sealing and extrusion performance.

A combination of an optimized seal geometry and premium grade material help to provide a longer and more reliable service life, thereby increasing productivity and profitability.

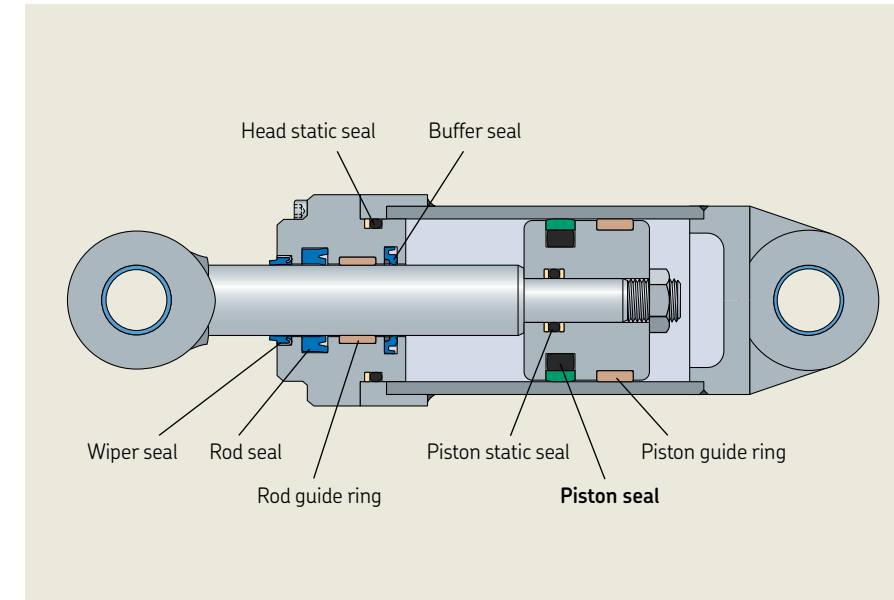

## MPV, DPV, LPV, CPV – seals for cylinder applications

During the development of any seal product, there is a continuous collaboration between different areas within Research and Development to assure that the required technology is developed, validated and successfully implemented.

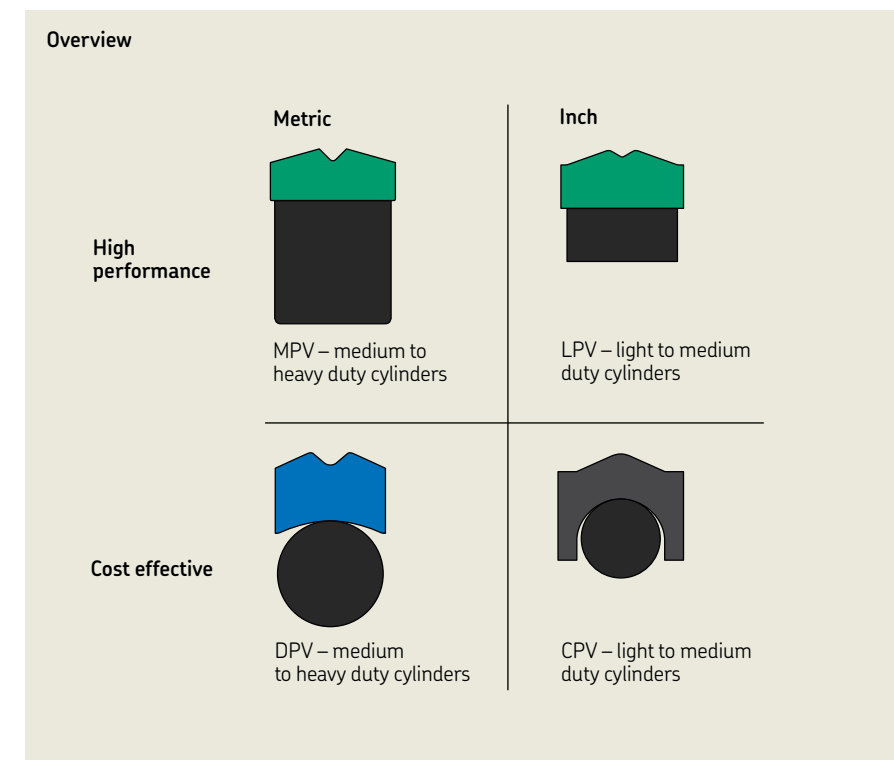

# MPV and DPV – premium grade sealing solutions for medium to heavy duty cylinders



The MPV (metric) and DPV (inch) are double-acting piston seals designed for medium to heavy duty cylinder applications. Both have an axially vented slide ring element made from X-ECOPUR PS (TPU). This is a special premium grade polyurethane compound with increased hardness, developed to offer improved performance at higher pressure ranges, reduce friction, offer excellent chemical stability and extrusion resistance when compared with other TPU and PTFE piston seals. Both piston seals are energized by a nitrile energizer.

The geometries of both, the MPV and the DPV have been optimized, using FEA (Finite Element Analysis), which contributes to consistent sealing performance over a long service life and over a wide range of system temperatures and pressures.

## Features and benefits

- MPV fits in ISO 7425-1 seal housings
- DPV fits in O-ring dash size housings
- Optimized for robust static and dynamic sealing performance over a wide range of pressures and temperatures
- Very good extrusion resistance
- Good low temperature flexibility
- Excellent wear resistance
- Long service lifetime due to optimized material and seal geometry
- Outperforms competitor medium/heavy duty piston seal products
- Easy installation

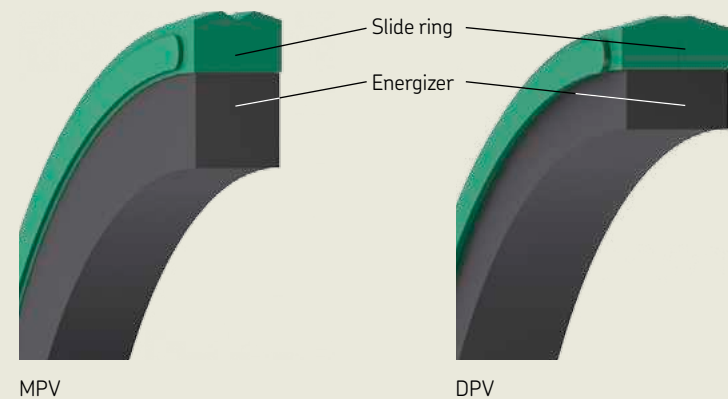

MPV

DPV

### MPV profile

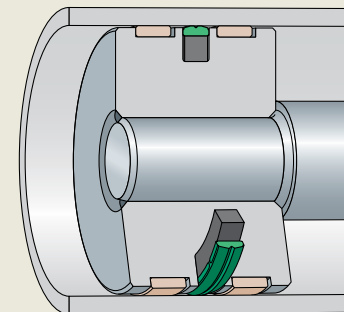

#### Product specifications

Material MPV: X-ECOPUR PS / NBR 80A  
 Pressure: Up to 400 bar (5 800 psi)  
 Speed: Up to 1 m/s (3,2 ft/s)  
 Size range: 50–200 mm

### DPV profile

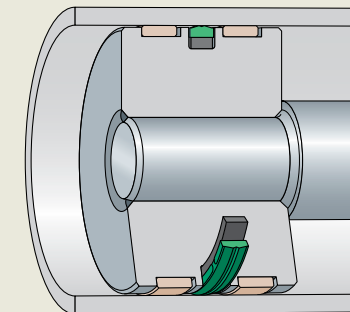

#### Product specifications

Material DPV: X-ECOPUR PS / NBR 70A  
 Pressure: Up to 400 bar (5 800 psi)  
 Speed: Up to 1 m/s (3,2 ft/s)  
 Size range: 1–6.002 inches

## Temperature range

### MPV

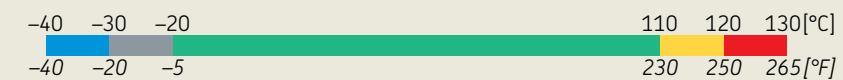

### DPV

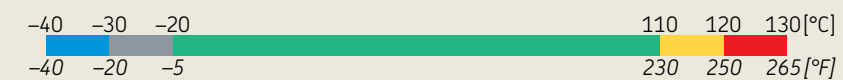

- Extreme low temperature range: may be intermittently exposed (e.g. cold start-up) without seal damage, but seal performance may be compromised while in this range
- Temperatures below the recommended operating range: seal performance depends on system design (precision guiding arrangement recommended)
- Recommended operating temperature range for this profile and material
- Temperatures above the recommended operating range: acceptable only with reduced pressure, speed, extrusion gap
- Extreme high temperature range: only occasional short-term exposure (e.g. a cylinder in an industrial powder coating oven)

## Meet extended market demands

Piston seals have to cope with larger gaps compared to rod seals. Therefore, an increased extrusion resistance is extremely important for the sealing material. On the other hand, if the material is too stiff, it can lead to installation problems. SKF's in-house R&D department has developed and tested a special polyurethane compound with optimized properties to meet both demands.

## X-ECOPUR PS

A new and improved material for the slide ring element. The material was validated in standard laboratory tests for seal materials, e.g. such as tensile properties and compression set.

An extrusion resistance test was conducted to verify, if the design intent of the MPV would be fulfilled.

A static extrusion test was performed under the following conditions:

Pressure: 500 bar (static)  
 Oil temperature: 60 / 80 / 100 °C  
 Extrusion gap: 0,15 / 0,30 / 0,50 / 0,70 mm  
 Test duration: 2 weeks

## X-ECOPUR PS test results

Compared to material used by a competitor for a slide ring, the X-ECOPUR PS material has improved extrusion resistance, as shown in the graphs below.

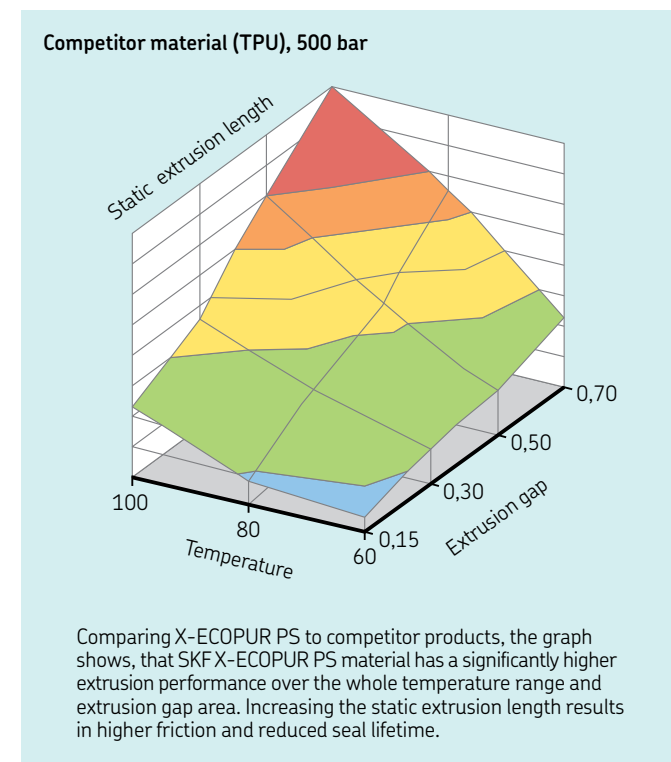
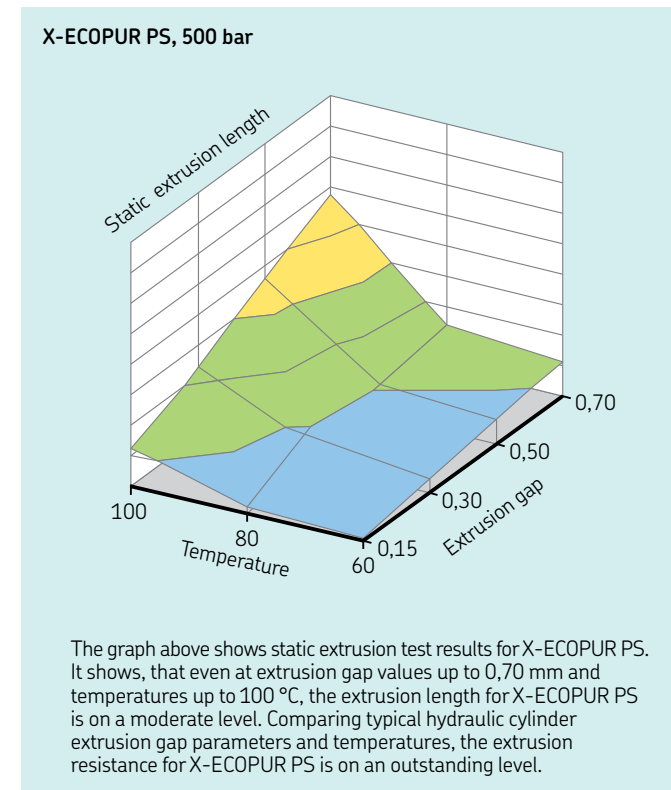

## MPV test results

The graphs below show, that the MPV outperforms the three competitor products on the evaluated seal performance characteristics.

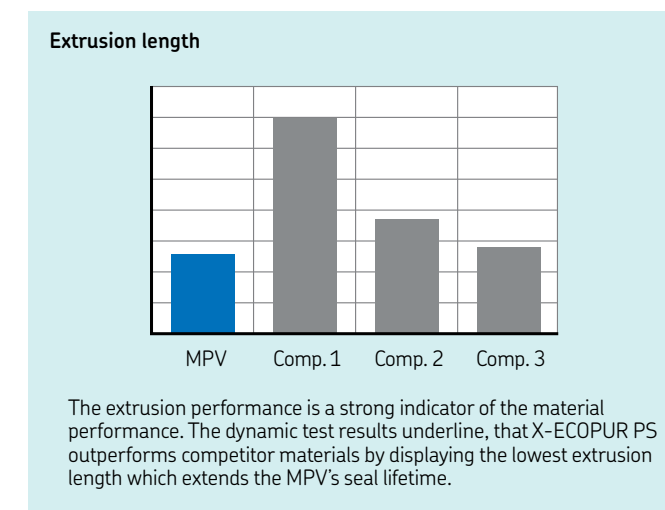
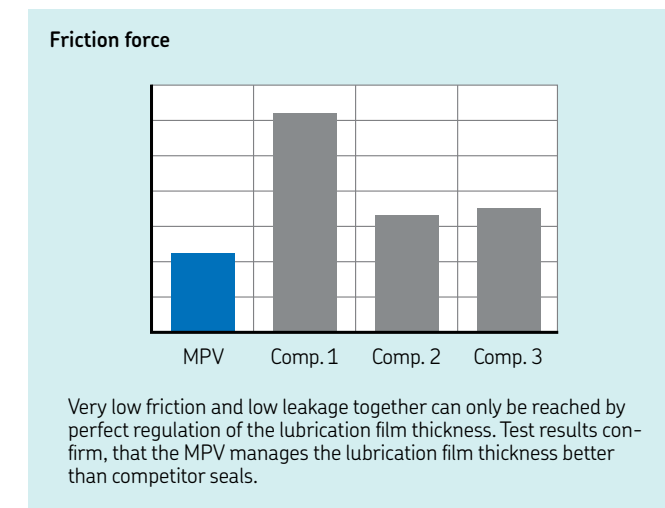
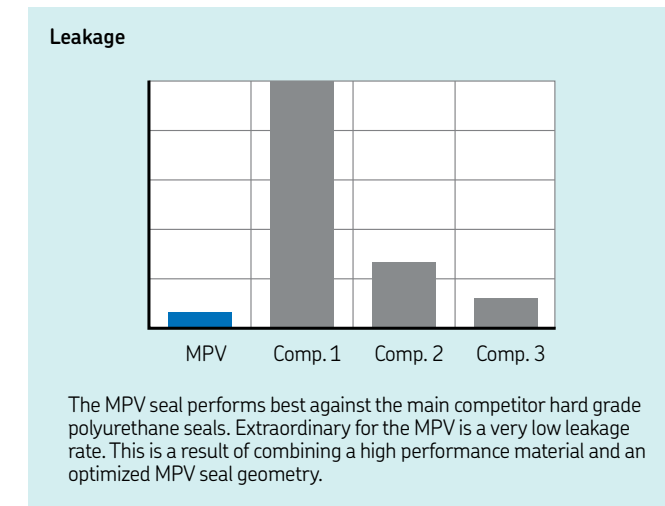

## DPV test results

The DPV utilizes the same high performance X-ECOPUR PS material as the MPV piston seal. FEA and cylinder testing validation methods were again used to verify the performance characteristics of the DPV seal.

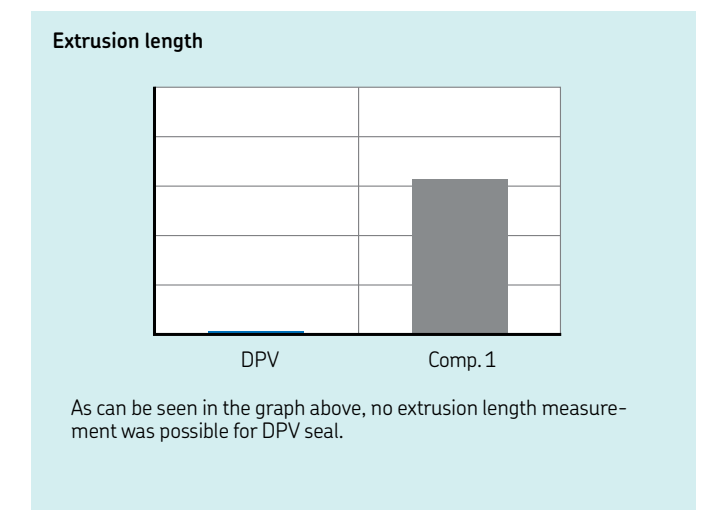
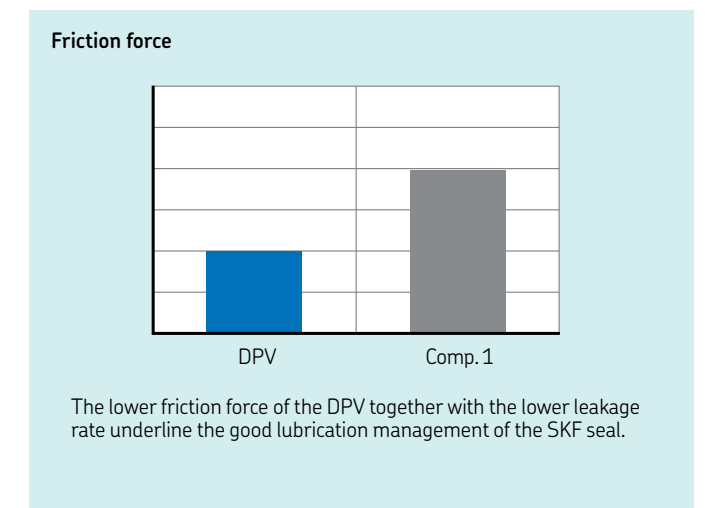
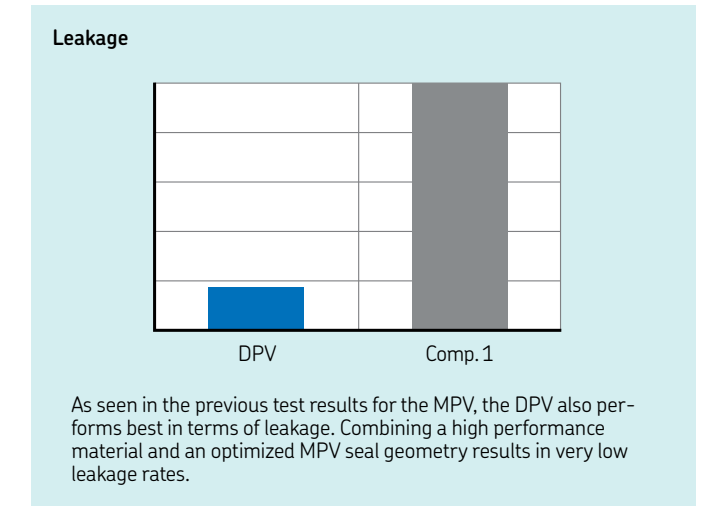

# LPV – cost effective sealing solution for light to medium duty cylinders



The LPV (metric) piston seal is a two-piece sealing solution consisting of an axially vented slide ring in blue hard grade polyurethane and a standard O-ring energizer in black nitrile rubber. The LPV is an ideal sealing solution for light to medium duty hydraulic double-acting piston seal applications. It is designed for metric cylinder bores and seal housings.

## Features and benefits

- Fits in ISO 7425-1 seal housings
- Optimized for robust static and dynamic sealing performance
- Good extrusion resistance
- Very good wear resistance
- Long service lifetime due to optimized material and seal geometry
- Outperforms competitor light duty piston seal products
- Easy installation
- Good performance for medium duty applications at low cost level

## LPV test results

The graphs on the right compares SKF's LPV with the double acting light duty piston seal of a leading competitor. The test results show, that the LPV seal has a very low leak rate, less slide ring extrusion and additionally lower friction, which increase the life time of the whole sealing system.

The compression set chart below shows the compression set behaviour of LPV piston seals made out of two different TPU glide ring materials. It clearly shows the excellent performance of the newly developed piston seal material ECOPUR PT 54D, which outperforms seals made of a commercially available TPU grade on compression set resistance properties, which is one of the key characteristics of a seal. It is responsible that the seal functions properly, minimizing the risk of blow-by during its total service life.

### Leakage

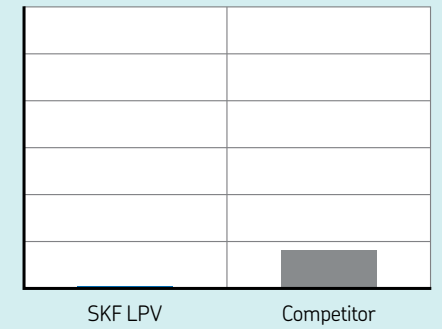

The leakage level for LPV is lower than the leakage of the tested competitor seal. The test results show that the adapting the material and seal geometry is the key for best sealing performance.

### Extrusion length

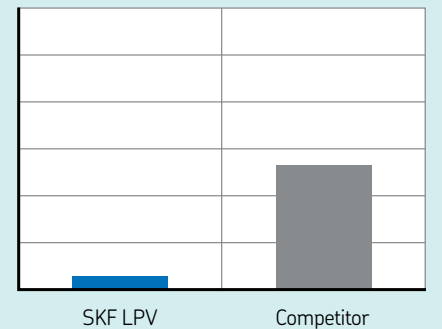

Apart from the compression set behaviour, the extrusion performance is a good indicator of the suitability of the sealing material. Test results underline the high quality of ECOPUR PT 54D, which outperforms competitors' on extrusion length.

### LPV profile

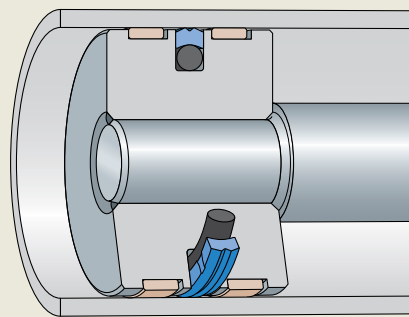

**Product specifications**  
 Material: ECOPUR PT 54D / NBR 70A  
 Pressure: Up to 250 bar (3 625 psi)  
 Speed: Up to 0,5 m/s (1,6 ft/s)  
 Size range: 25-100 mm

### Temperature range, LPV

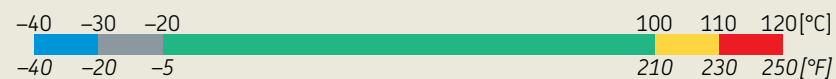

See temperature bar caption on page 5.

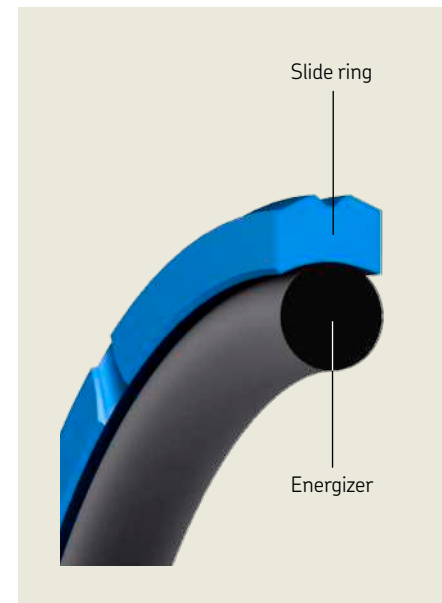

### Compression set

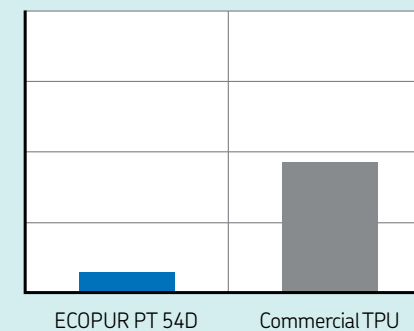

Very low compression set for ECOPUR PT 54D, which increase seal lifetime because of lower preload loss. The graph underlines, that the material performs well, when proper care is taken in the selection of the sealing material and seal geometry.

### Average friction force

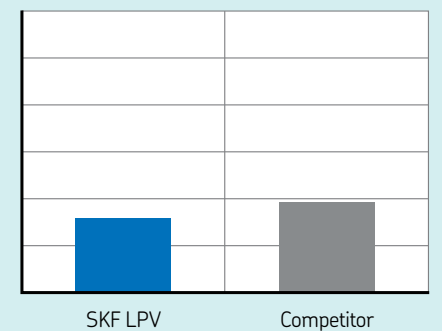

The frictional force of Competitor seal is nearly on the same level as LPV but just because of a thicker lubrication film which result in more leakage.

# CPV – cost effective sealing solution for light to medium duty cylinders



The CPV (inch) piston seal is designed to fit AS568-A O-Ring grooves. It is a two-piece sealing solution, consisting of a slide ring (shell design) in black polyurethane, with an axially vented surface and an energizer in black nitrile rubber.

The CPV is a cost effective sealing solution for light to medium duty hydraulic double-acting piston seal applications. It is designed for inch cylinder bores and seal housings requiring high sealability.

## Features and benefits

- Improved low pressure and long term sealability
- Improved extrusion and wear resistance
- Ensures, that O-ring is under fluid pressure and that the seal is energized
- Optimized for robust static and dynamic sealing performance
- Designed to retrofit AS568-A O-ring grooves
- Easy installation

## A complete offering – from one piece to one million

SKF offer a comprehensive selection of sealing products for extremely demanding applications. Whether you require high quantities for larger production volumes or a single replacement seal, SKF can meet your product and delivery needs.

These piston seals from SKF utilise our capability to seamless transfer between manufacturing processes – from a single piece to high volume production. This flexibility delivers quality sealing products that provide maximum value to all customers.

## Manufacturing flexibility

Whether you need a single seal or a high-volume production run, SKF can support your needs. Our flexible seal production model combines moulded and machined manufacturing capabilities to accommodate virtually any demand.

With competencies in compression, injection and transfer moulding technologies, SKF can apply the most appropriate option for your requirements. With the machined seals concept, we are also able to provide machined seals very quickly, without tooling costs.

## Product life cycle stages

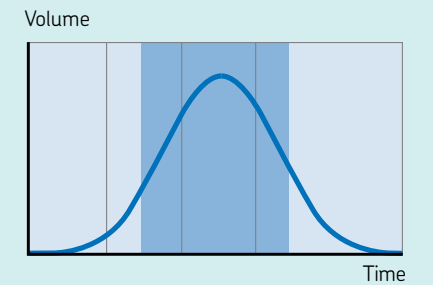

- Machined seals**  
 To cost effectively produce prototypes and seals in low volumes with short delivery time (in the introduction, initial growth, declining phase and to meet replacement demand).
- Moulded seals**  
 To cost effectively produce seals in high volumes (in the growth and maturity phase).

### CPV profile

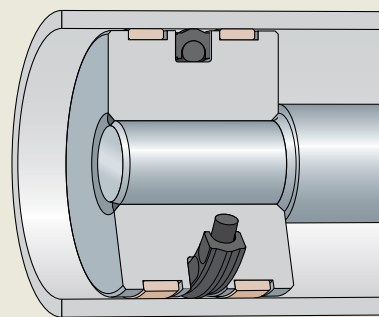

Material: LUBRITHANE U-1003 / NBR 70A  
 Pressure: Up to 365 bar (5 000 psi)  
 Speed: Up to 0,5 m/s (1.6 ft/s) > 250 bar  
 Up to 1 m/s (3.2 ft/s) ≤ 250 bar  
 Size range: 1.5 – 9.002 inch

### Temperature range, CPV

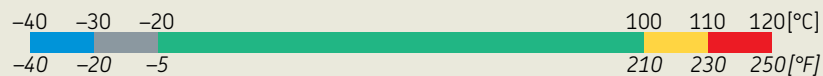

See temperature bar caption on page 5.

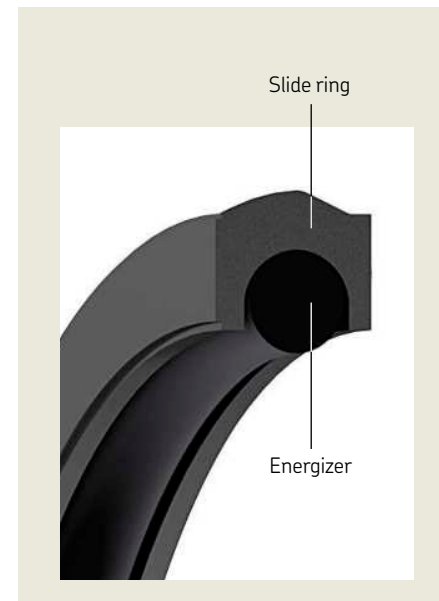

## SKF Research & Development – breakthrough technology

Collaboration between various SKF Research & Development teams results in the latest breakthrough technology being developed, validated and successfully implemented.

The most critical aspect about the SKF R&D department is the interaction between the 5 separate focus areas.

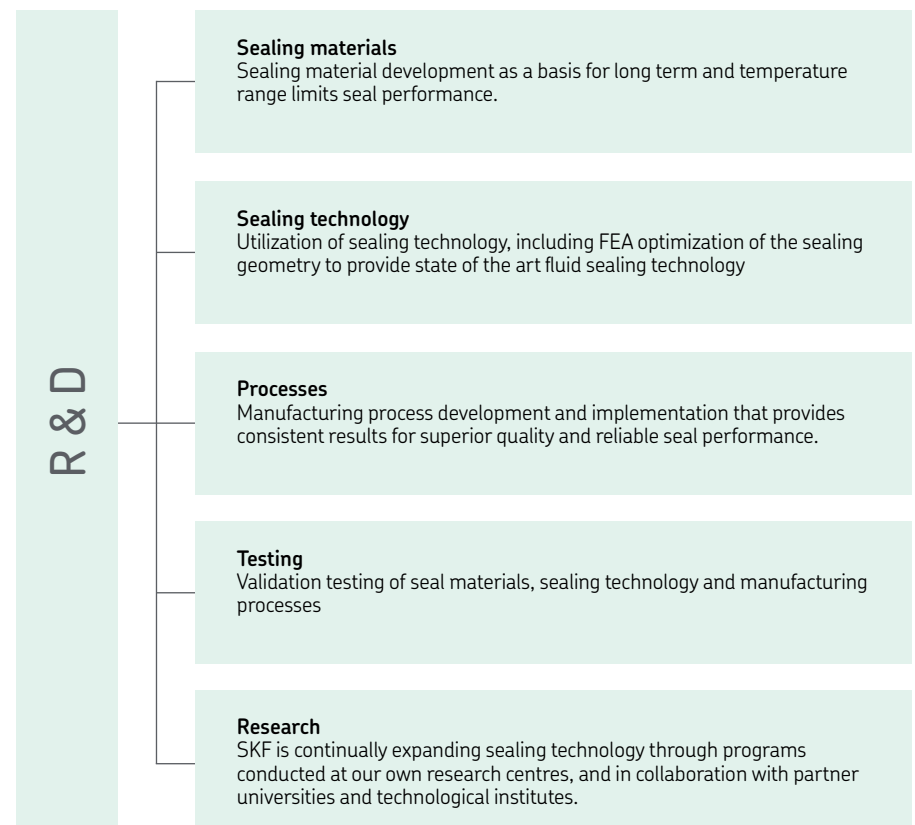

## SKF – your sealing partner

SKF offer a comprehensive selection of sealing products for extremely demanding applications. The premium MPV and DPV piston seals feature the highest quality design and materials, offering maximum value to all customers.

Whether you require high quantities for production volumes or a single replacement seal, SKF can meet your product delivery needs. Flexible seal manufacturing capability consists of both moulded and machined processes to accommodate virtually any product demand. Trust in SKF as your sealing partner.



[skf.com](http://skf.com) | [second.url.com](http://second.url.com) | [third.url.com](http://third.url.com)

© SKF, X-ECOPUR and ECOPUR are registered trademarks of the SKF Group.

© SKF Group 2017

The contents of this publication are the copyright of the publisher and may not be reproduced (even extracts) unless prior written permission is granted. Every care has been taken to ensure the accuracy of the information contained in this publication but no liability can be accepted for any loss or damage whether direct, indirect or consequential arising out of the use of the information contained herein.

PUB SE/S9 17145 EN · February 2017