

MPB

Pneumatic barrel pump

(English translation of operating and maintenance instructions compliant with EU Directive 2006/42/EC)



Date: **17.6.2022**

Document no.: **MPB**

Version: 1D



Read this manual before installing or commissioning the product and keep it at hand for later reference!

Original EC Declaration of Incorporation in accordance with Directive 2006/42/EC, Appendix II Part 1 B

The manufacturer hereby declares at its sole responsibility that the partly completed machinery conforms to the essential health and safety requirements of the Machinery Directive 2006/42/EC, Annex I, marked in the Annex to the EC Declaration of Incorporation as applicable and fulfilled at the time of placing on the market.

The special technical documents were prepared following Annex VII part B. Upon justifiable request, these special technical documents can be forwarded electronically to the respective national authorities. The authorized company for the compilation of the technical documentation is the manufacturer.

Designation: Pneumatically-operated barrel pump for lubricants
Type SKF-MPB-PUMP-1/1; SKF-MPB-PUMP-1/4; SKF-MPB-PUMP-1/8; SKF-MPB-PUMP-1/X-1:20

Furthermore, the following directives and standards were applied in the respective applicable areas:
2011/65/EU: ROHS II including the addition (EU) 2015/863

Machinery Directive 2006/42/EC: EN ISO 12100-1/A1, EN ISO 12100-2/A1
Pneumatic power transmission: EN ISO 4414:2011-4

The partly completed machinery must not be put into service until it has been established that the machinery into which it is to be incorporated is in compliance with the provisions of the Machinery Directive 2006/42/EC and all other applicable Directives.

Muurame, 24.5.2022
Juha Kärkkäinen
Design Office Manager
SKF Lubrication Management
Manufacturer: Oy SKF Ab Finland Teollisuustie 6 40951 Muurame FINLAND



Original UK Declaration of incorporation according to the Supply of Machinery (Safety) Regulations 2008 No. 1597 Annex II

The manufacturer hereby declares under sole responsibility that the partly completed machinery complies with the essential health and safety requirements of UK legislation Supply of Machinery (Safety) Regulations 2008 No. 1597 Annex I, marked in the Annex to the EC Declaration of Incorporation as applicable and fulfilled at the time of placing on the market.

The special technical documents were prepared following Annex VII part B. Upon justifiable request, these special technical documents can be forwarded electronically to the respective national authorities. The authorized company for the compilation of the technical documentation is SKF (U.K.) Limited, 2 Canada Close, Banbury, Oxfordshire, OX16 2RT, GBR.

Designation: Pneumatically-operated barrel pump for lubricants
Type SKF-MPB-PUMP-1/1; SKF-MPB-PUMP-1/4; SKF-MPB-PUMP-1/8; SKF-MPB-PUMP-1/X-1:20

Furthermore, the following regulations and standards were applied in the respective applicable areas:

- The Restriction of the Use of Certain Hazardous Substances in Electrical and Electronic Equipment Regulations 2012 No. 3032

EN ISO 12100-1/A1 EN ISO 12100-2/A1 EN ISO 4414:2011-4

The partly completed machinery must not be put into service until it has been established that the machinery into which it is to be incorporated is in compliance with the provisions of UK legislation Supply of Machinery (Safety) Regulations 2008 No. 1597 and all other applicable Directives.

Muurame, 24.5.2022
Juha Kärkkäinen
Design Office Manager
SKF Lubrication Management
Manufacturer: Oy SKF Ab Finland Teollisuustie 6 40951 Muurame



Appendix to Declaration of Incorporation in accordance with 2006/42/EC, Annex II, No. 1 B

Description of the essential health and safety requirements according to 2006/42/EC, Annex I, which have been applied and fulfilled. Any essential health and safety requirements not listed here are not relevant to this product

Table 1

Appendix to Declaration of Incorporation Valid for: MPB lubrication pumps			
No.:	Essential health and safety requirement	Applicable:	Fulfilled:
1.1.1	Definitions	Yes	Yes
1.1.2	Principles of safety integration	Yes	Yes
1.1.3	Materials and products	Yes	Partially ¹⁾
1.1.5	Design of machinery to facilitate its handling	Yes	Yes
1.3	Protection against mechanical hazards	Yes	Yes
1.3.1	Risk of loss of stability	Yes	Yes
1.3.2	Risk of break-up during operation	Yes	Yes
1.3.4	Risks due to surfaces, edges or angles	Yes	Yes
1.3.7	Risks related to moving parts	Yes	Yes
1.3.9	Risks of uncontrolled movements	Yes	Yes
1.5	Risks due to other hazards	Yes	Yes
1.5.3	Energy supply other than electricity	Yes	Yes
1.5.8	Noise	Yes	Yes
1.6	Maintenance		
1.6.1	Machinery maintenance	Yes	Yes
1.7	Information	Yes	Yes
1.7.1	Information and warnings on the machinery	Yes	Yes
1.7.2	Warning of residual risks	Yes	Yes
1.7.3	Marking of machinery	Yes	Yes
1.7.4	Instructions	Yes	Yes

1) Not completely fulfilled: Hazards due to the lubricant used must be assessed by the operator on the basis of the Safety Data Sheet (SDS) and, if necessary, protective measures must be taken.

Masthead

Manufacturer

Oy SKF Ab
Teollisuustie 6 P.O Box 80
40951 Muurame, Finland
Email: skf-lube@skf.com
www.skf.com/lubrication

Authorized local distributors

- Great Britain -
SKF (U.K.) Limited,
2 Canada Close, Banbury, Oxfordshire,
OX16 2RT, GBR.

- North America -

SKF Lubrication Business Unit
Lincoln Industrial
5148 North Hanley Road, St. Louis,
MO. 63134 USA

- South America -

SKF Argentina Pte. Roca 4145,
CP 2001 Rosario, Santa Fe

Warranty

The instructions contain no statements regarding the warranty or liability for defects. That information can be found in our General Terms of Payment and Delivery.

Training

We conduct detailed training in order to enable maximum safety and efficiency. We recommend taking advantage of this training. For further information, contact your authorized SKF dealer or the manufacturer.

Table of contents

Masthead	4
Table of contents	5
Safety alerts, visual presentation, and layout	6
1. Safety instructions	7
1.1 General safety instructions	7
1.2 General electrical safety instructions	7
1.3 General behaviour when handling the product	7
1.4 Intended use	7
1.5 Persons authorized to use the product	8
1.6 Foreseeable misuse	8
1.7 Referenced documents	8
1.8 Prohibition of certain activities	8
1.9 Painting plastic components and seals	8
1.10 Safety markings on the product	8
1.11 Notes on the type plate	9
1.12 Note on Pressure Equipment Directive	9
1.13 Notes on CE marking	9
1.14 Notes related to the UKCA marking	9
1.15 Note on EAC marking	9
1.16 Note on China RoHS mark	10
1.17 Emergency shutdown	10
1.18 Assembly, maintenance, fault, repair	10
1.19 First start-up, daily start-up	10
1.20 Residual risks	11
2. Lubricants	12
2.1 General information	12
2.2 Material compatibility	12
2.3 Temperature properties	12
2.4 Aging of lubricants	12
2.5 Avoidance of faults and hazards	12
2.6 Solid lubricants	13
3. MPB pump general description	14
4. Commissioning	15
5. Main components	16
6. Periodic inspections	17
7. Troubleshooting	17
7.1 Malfunctions	17
7.2 Troubleshooting table	18
8. Technical information	19
8.1 Pump output curve	20
8.2 MPB pump configurations	21
8.3 Designation and order codes	22
9. Shutdown, decommissioning and storage	23
9.1 Temporary shutdown	23
9.2 Final decommissioning	23
9.3 Storage	23
10. Spare parts	24
11. Pneumatic barrel pump 1:20	25
11.1 MPB 1:20 pump general description	25
11.2 Commissioning	26
11.3 Main components	27
11.4 Technical specifications of MPB 1:20	28
11.5 Output curve of MPB 1:20	29
11.6 Designation and order codes	30
11.7 Spare parts MPB 1:20	31
12. Appendix	32
12.1 China RoHS Table	32

Safety alerts, visual presentation, and layout

While reading these instructions, you will encounter various symbols, illustrations, and text layouts intended to help you navigate and understand the instructions. Their meaning is explained below.

Safety alerts:

Activities that present specific hazards (to life and limb or possible damage to property) are indicated by safety alerts. Always be sure to follow the instructions given in the safety alerts.

DANGER

These safety alerts indicate an imminent danger. Ignoring them will result in death or serious injury

WARNING

These safety alerts indicate potentially imminent danger. Ignoring them could result in death or serious injury

CAUTION

These safety alerts indicate potentially imminent danger. Ignoring them could result in minor injury

NOTICE

These safety alerts indicate a potentially harmful situation. Ignoring them could result in damage to property or malfunctions

Illustrations:

The illustrations used depict a specific product. For other products, they may have the function of a diagram only. This does not alter the basic workings and operation of the product.

Text layout:

- **First-order bulleted lists:** Items on a bulleted list start with a solid black dot and an indent.
 - **Second-order bulleted lists:** If there is a further listing of subitems, the second-order bulleted list is used.
- 1 Legend:** A legend explains the numbered contents of an illustration, presented as a numbered list. Items in a legend start with a number (with no dot) and an indent.
 - Second-order legend: In some cases, the numbered contents of an image represent more than just one object. A second-order legend is then used.
- 1. Instruction steps:** These indicate a chronological sequence of instruction steps. The numbers of the steps are in bold and are followed by a period. If a new activity follows, the numbering starts again at “1.”
 - **Second-order instruction steps:** In some cases, it is necessary to divide up a step into a few sub steps. A sequence of second-order instruction steps is then used.

1. Safety instructions

1.1 General safety instructions

- Putting the products into operation or operating them without having read the instructions is prohibited. The operator must ensure that the instructions are read and understood by all persons tasked with working on the product or who supervise or instruct such persons. Retain the instructions for further use.
- The product may only be used in awareness of the potential dangers, in proper technical condition, and according to the information in this manual.
- Any faults that could affect safety must be remedied according to responsibility. The supervisor must be notified immediately in case of malfunctions outside one's individual scope of responsibility.
- Unauthorized modifications and changes can have an unpredictable effect on safety and operation. Unauthorized modifications and changes are therefore prohibited. Only original SKF spare parts and SKF accessories may be used.
- Any unclear points regarding proper condition or correct assembly/operation must be clarified. Operation is prohibited until issues have been clarified.
- The components used must be suitable for the intended use and the applicable operating conditions, e.g. max. operating pressure and ambient temperature range, and must not be subjected to torsion, shear, or bending.

1.2 General electrical safety instructions

- Electrical devices must be kept in proper condition. This must be ensured by periodic inspections in accordance with the relevant applicable standards and technical rules. The type, frequency, and scope of the inspections must be determined in accordance with the risk assessment to be carried out by the operator. Work on electrical components may be performed only by qualified electricians. Connect the electrical power only in accordance with the valid terminal diagram and in observance of the relevant regulations and the local electrical supply conditions.
- Work on electrical components may be performed only in a voltage-free state and using tools suitable for electrical work. Do not touch cables or electrical components with wet or moist hands.
- Fuses must not be bridged. Always replace defective fuses with fuses of the same type.
- Ensure proper connection of the protective conductor for products with protection class I. Observe the specified enclosure rating.
- The operator must implement appropriate measures to protect vulnerable electrical devices from the effects of lightning during use. The electrical device is not furnished with a grounding system for the dissipation of the respective electric charge and does not have the voltage strength necessary to withstand the effects of lightning.

1.3 General behaviour when handling the product

- Familiarize yourself with the functions and operation of the product. The specified assembly and operating steps and their sequences must be observed.
- Keep unauthorized persons away.
- Wear personal protective equipment always.
- Precautionary operational measures and instructions for the respective work must be observed.
- In addition to these Instructions, general statutory regulations for accident prevention and environmental protection must be observed.
- Precautionary operational measures and instructions for the respective work must be observed. Uncertainty seriously endangers safety.
- Safety-related protective and safety equipment must not be removed, modified or affected otherwise in its function and is to be checked at regular intervals for completeness and function.
- If protective and safety equipment has to be dismantled, it must be reassembled immediately after finishing the work, and then checked for correct function.
- Remedy occurring faults in the frame of responsibilities. Immediately inform your superior in the case of faults beyond your competence.
- Never use parts of the centralized lubrication system or of the machine as standing or climbing aids.

1.4 Intended use

Supply of lubricants.

The product is intended solely for installation in another machine.

Use is only permitted within the scope of commercial or economic activity by professional users, in compliance with the specifications, technical data, and limits specified in this manual.

1.5 Persons authorized to use the product

Operator

A person who is qualified by training, knowledge and experience to carry out the functions and activities related to normal operation. This includes avoiding possible hazards that may arise during operation.

Specialist in mechanics

Person with appropriate professional education, knowledge and experience to detect and avoid the hazards that may arise during transport, installation, start-up, operation, maintenance, repair and disassembly.

Specialist in electrics

Person with appropriate professional education, knowledge and experience to detect and avoid the hazards that may arise from electricity.

1.6 Foreseeable misuse

Any usage of the product other than as specified in this manual is strictly prohibited. Particularly prohibited are:

- Use of non-specified consumables, contaminated lubricants, or lubricants with air inclusions.
- Use of C3 versions in areas with aggressive, corrosive substances (e.g., high salt load).
- Use of plastic parts in areas with high exposure to ozone, UV light, or ionizing radiation.
- Use to supply, convey, or store hazardous substances and mixtures as defined in the CLP Regulation (EC 1272/2008) or GHS with acute oral, dermal, or inhalation toxicity or substances and mixtures that are marked with hazard pictograms GHS01-GHS06 and GHS08.
- Use to supply, convey, or store Group 1 fluids classified as hazards as defined in the Pressure Equipment Directive (2014/68/EU) Article 13 (1) a).
- Use to supply, convey, or store gases, liquefied gases, dissolved gases, vapors, or fluids whose vapor pressure exceeds normal atmospheric pressure (1013 mbar) by more than 0.5 bar at their maximum permissible operating temperature.
- Use in an explosion protection zone.
- Use without proper securing against excessively high pressures, in the case of pressurized products.
- Use outside of the technical data and limits specified in this manual.

1.7 Referenced documents

In addition to this manual, the following documents must be observed by the respective target group:

- Company instructions and approval rules

If applicable:

- Safety data sheet of the lubricant used
- Project planning documents
- Supplementary information regarding special designs of the pump. This you will find in the special system documentation.
- Instructions for other components for setting up the centralized lubrication system.

1.8 Prohibition of certain activities

- Replacement of or modifications to the pistons of the pump elements
- Repairs or modifications to the drive

1.9 Painting plastic components and seals

The painting of any plastic components and seals of the products described is prohibited. Completely mask or remove plastic components before painting the main machine.

1.10 Safety markings on the product

NOTE

Further to the findings of the workplace risk evaluation the operating company has to attach additional markings (e. g. warnings, signs giving orders, prohibition signs or labelling as specified by CLP / GHS), where appropriate.

1.11 Notes on the type plate

The type plate provides important data such as the type designation, order number, and sometimes regulatory characteristics. To avoid loss of this data in case the type plate becomes illegible, it should be entered in the manual.

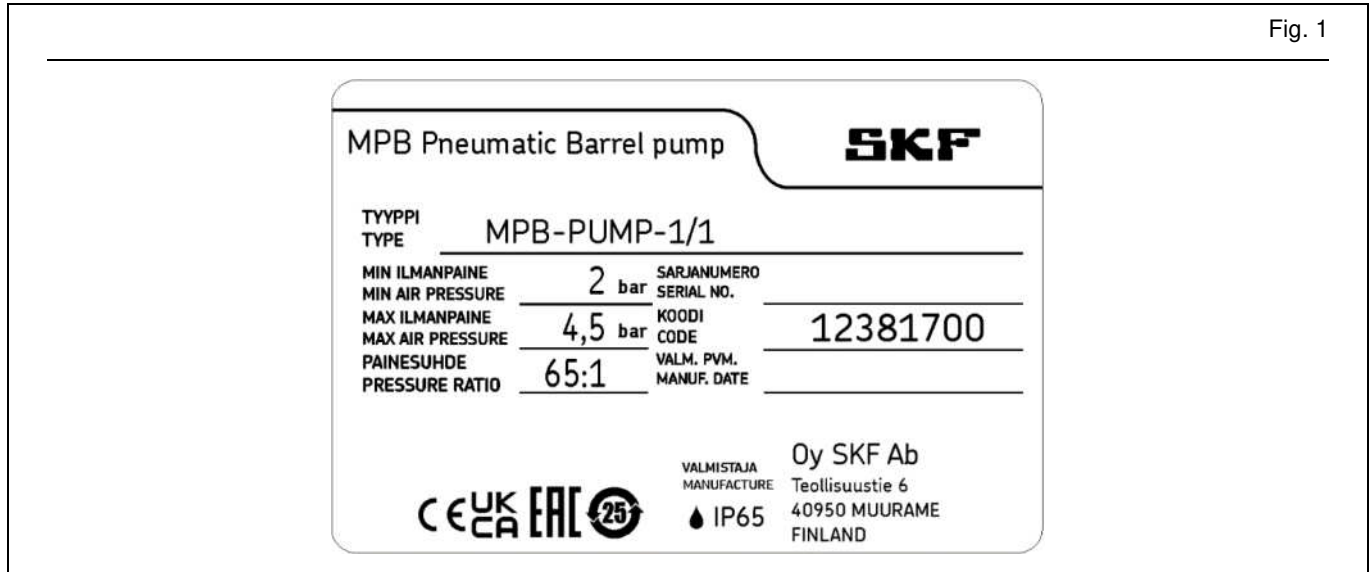

Type identification plate

1.12 Note on Pressure Equipment Directive

Due to its performance characteristics, the product does not reach the limit values defined in Article 4, Paragraph 1, Subparagraph (a) (ii) and is excluded from the scope of Pressure Equipment Directive 2014/68/EU in accordance with Article 1, Paragraph 2 Subparagraph (f).

1.13 Notes on CE marking

CE CE marking is effected following the requirements of the applied directives requiring a CE marking:

- 2011/65/EU Directive on the restriction of the use of certain hazardous substances in electrical and electronic equipment (RoHS II)

1.14 Notes related to the UKCA marking

UKCA The UKCA conformity marking confirms the product's conformity with the applicable legal provisions of Great Britain.

1.15 Note on EAC marking

EAC The EAC conformity marking confirms the product's conformity with the applicable legal provisions of the Eurasian customs union.

1.16 Note on China RoHS mark



The China RoHS marking confirms that there is no danger to persons or the environment from the regulated substances contained within the intended period of use (number in the circle) of the product.

1.17 Emergency shutdown

This is done by a course of action to be defined by the operator.

1.18 Assembly, maintenance, fault, repair

Prior to the start of this work, all relevant persons must be notified of it. At a minimum, the following safety measures must be taken before any work is done:

- Unauthorized persons must be kept away
- Mark and secure the work area
- Cover adjacent live parts
- Dry any wet, slippery surfaces or cover them appropriately
- Cover hot or cold surfaces appropriately

Where applicable:

- Depressurize
- Isolate, lock and tag out
- Check to ensure live voltage is no longer present
- Ground and short-circuit

The product should be protected as much as possible from humidity, dust, and vibration, and should be installed so that it is easily accessible. Ensure an adequate distance from sources of heat or cold. Any visual monitoring devices present, such as pressure gauges, min./max. markings, or oil level gauges must be clearly visible. Observe the mounting position requirements.

Drill required holes only on non-critical, non-load-bearing parts of the operator's infrastructure. Use existing holes where possible. Avoid chafe points. Immobilize any moving or detached parts during the work. Adhere to the specified torques.

If guards or safety devices need to be removed, they must be reinstalled immediately following conclusion of work and then checked for proper function.

Check new parts for compliance with the intended use before using them.

Avoid mixing up or incorrectly assembling disassembled parts. Label parts. Clean any dirty parts.

1.19 First start-up, daily start-up

Ensure that:

- All safety devices are fully present and functional
- All connections are properly connected
- All parts are correctly installed
- All warning labels on the product are fully present, visible, and undamaged
- Illegible or missing warning labels are immediately replaced

2. Lubricants

2.1 General information

Lubricants are selected specifically for the relevant application. The manufacturer or operator of the machine should ideally make the selection in consultation with the supplier of the lubricant. If you have no or little experience in selecting lubricants for lubrication systems, please contact us. We would be happy to assist you in selecting suitable lubricants and components to build a lubrication system optimized for your application. Consider the following points when selecting/using lubricants. This will spare you potential downtime and damage to the machine or lubrication system.

2.2 Material compatibility

The lubricants must generally be compatible with the following materials:

- Plastics: ABS, CR, FPM, NBR, NR, PA, PET, PMMA, POM, PP, PS, PTFE, PU, PUR
- Metals: steel, gray cast iron, brass, copper, aluminum

2.3 Temperature properties

The lubricant used must be suitable for the specific ambient temperature of the product. The viscosity approved for proper functioning must neither be exceeded at low temperatures nor fall too low at high temperatures. For the approved viscosity, see the "Technical data" chapter.

2.4 Aging of lubricants

Based on experience with the lubricant used, checks should be conducted at regular intervals defined by the operator, to determine whether the lubricant needs to be replaced due to aging processes (oil separation). In case of doubt regarding the continued suitability of the lubricant, it must be replaced before the system is started up again. If you do not yet have any experience with the lubricant used, we recommend conducting a check after just one week.

2.5 Avoidance of faults and hazards

To avoid faults and hazards, please observe the following:

- When handling lubricants, observe the relevant safety data sheet (SDS) and any hazard labeling on the packaging.
- Due to the large number of additives, some lubricants that meet the pumpability requirements specified in the manual are not suitable for use in centralized lubrication systems.
- Whenever possible, always use SKF lubrication greases. They are ideal for use in lubrication systems.
- Do not mix lubricants. This can have unpredictable effects on the properties and usability of the lubricant.
- Use lubricants containing solid lubricants only after technical consultation with SKF.
- The lubricant's ignition temperature has to be at least 50 Celsius above the maximum surface temperature of the components.

2.6 Solid lubricants

Solid lubricants may only be used after prior consultation with SKF. When solid lubricants are used in lubrication systems, the following rules generally apply:

Graphite:

- Maximum graphite content 8%
- Maximum grain size 25 µm (preferably in lamellar form)

MoS₂:

- Maximum MoS₂ content 5%
- Maximum grain size 15 µm

Copper:

- Lubricants containing copper are known to lead to coatings forming on pistons, bore holes, and mating surfaces. This can result in blockages in the centralized lubrication system.

Calcium carbonate:

- Lubricants containing calcium carbonate are known to lead to very heavy wear on pistons, bore holes, and mating surfaces.

Calcium hydroxide:

- Lubricants containing calcium hydroxide are known to harden considerably over time, which can lead to failure of the centralized lubrication system.

PTFE, zinc, and aluminum:

- For these solid lubricants, it is not yet possible to define any limit values for use in lubrication systems on the basis of existing knowledge and practical experience.

3. MPB pump general description

The purpose of the pump is to supply lubricant to a centralised lubrication system. The pump is suitable for greases up to grade 000-2 (NLGI), and it has both an outlet connection (pressure connection, "P") and a return connection (tank connection, "T"). Its pressure ratio is 1:65, which means that the pump's maximum allowable lubricant pressure (≈ 300 bar, 30 MPa) is achieved at 4.5 bar air pressure. The minimum air pressure required for operation is 2 bar (0.2 MPa).

SKF-MPB-PUMP is composed of an air motor and a pump unit. The air motor is controlled by a pneumatic valve, which in turn is controlled by a mechanical valve controller. The mechanical valve controller follows the motion of the air motor's air piston. A connecting rod transmits the motion of the air piston to the pump unit's piston assembly, which pressurises the lubricant. The air motor has been designed to be lubrication-free, which means that no lubricator is needed in the air filter regulator assembly.

The pump is intended for central lubrication systems consisting of a pump and lid set, air filter regulator and lubrication system control unit (each sold separately). Installing the MPB pump in an existing system driven by an SKF-EPB pump requires an additional installation kit, which includes the components required for connecting the pump in the lubrication system.

NOTICE

The pump is intended for intermittent use only. If the pump is used continuously at high pressure, or moist pressurised air is used, the pneumatic valve may freeze, causing a malfunction.

4. Commissioning

The pump is activated when air (minimum pressure: 2 bar) is supplied to its pressurised air inlet (4). The pump pressurises the lubricant, transferring it through the lubricant outlet (5) into the lubrication system. The pump also includes a tank connection (6). During depressurisation, lubricant returns through the tank connection into the pump pipe and, from there, back to the lubricant barrel. Lubricant pressure can be adjusted from the pressure air regulator (sold separately). When used in a central lubrication system, the pump's air supply is controlled by a control centre (sold separately) following user-defined lubrication values.

The pump can be equipped with a low lubricant level alarm (sold separately), which is connected to the lubrication system's control centre.

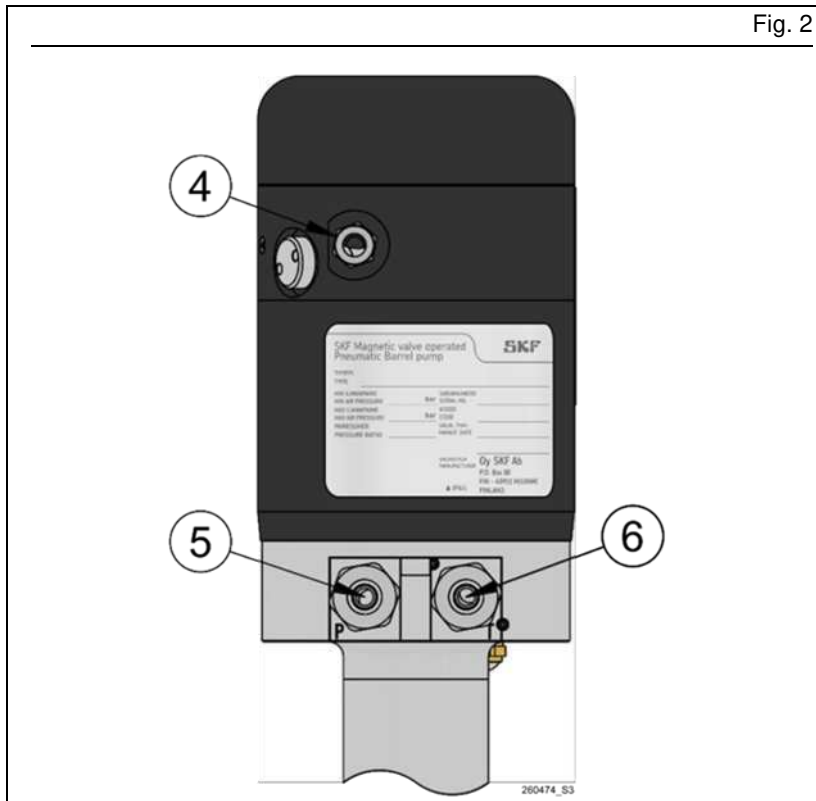

Pressurised air inlet (4)
Quick connector, 8 mm, G1/4"
Hydraulic connections (5, 6):

(5), P = Pressure, lubricant outlet, G1/4", basic connector, 12 L
(6), T = Tank, lubricant inlet, G1/4", basic connector, 12 L

5. Main components

MPB pump consists of the following components (Figure 3):

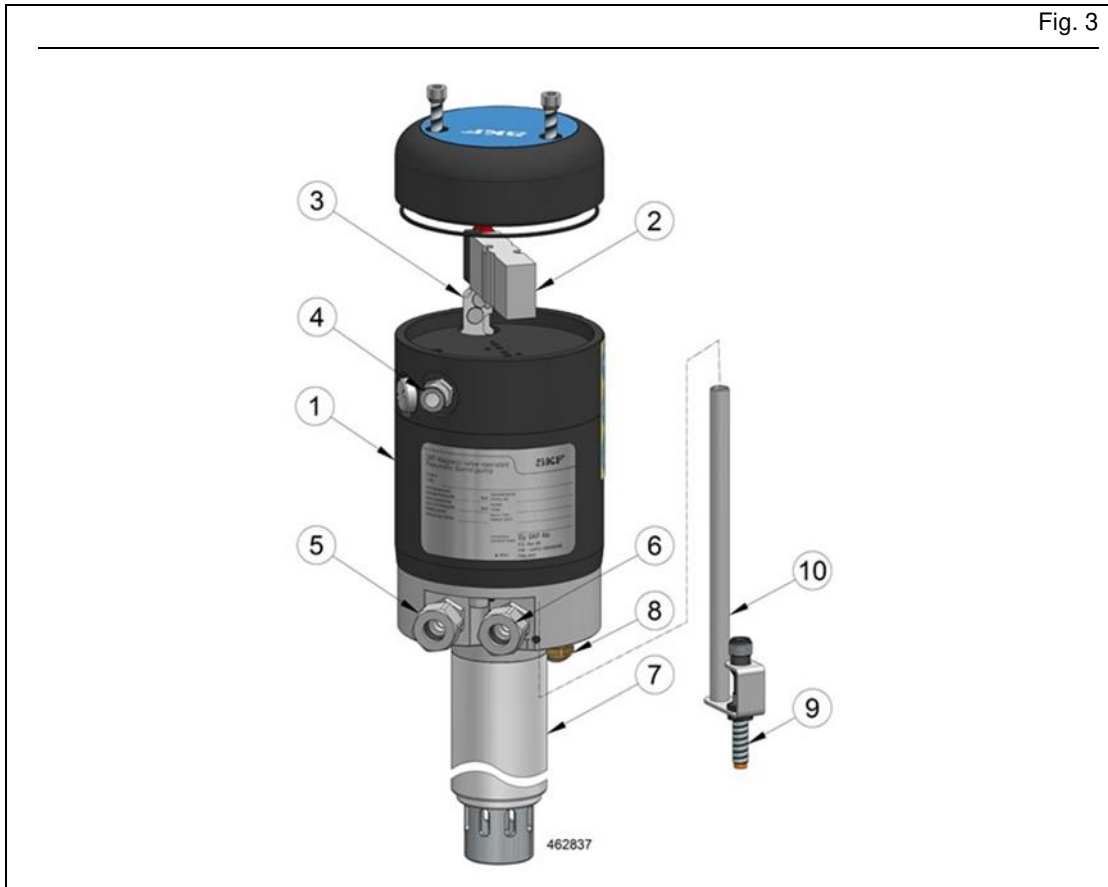

Table 3

Main components

Item	Description
1	Air motor
2	Pneumatic valve
3	Valve controller
4	Pressurised air inlet, G1/4", Ø8 quick connector
5	Pressure connection (hydraulic outlet), G1/4", basic connector, 12L
6	Tank connection (return inlet), G1/4", basic connector, 12L
7	Pump unit
8	Air exhaust muffler
9	Inductive sensor (included in the ECO lid set)
10	Low level switch bracket (included in the ECO lid set)

6. Periodic inspections

Monthly inspections

- Inspect the pressure air regulator and drain it of water.
- Check the pump's operation.
- Check the pump and lubrication system for leaks.

When replacing the barrel (in addition to the above):

- Clean the grease filter and the filter cartridge and replace them if necessary.

7. Troubleshooting

WARNING



Before addressing the following malfunctions, turn off the power from the control and pumping centre, isolate the pressurised air supply and depressurise the lubrication line connected to the pump outlet. Any residual pressure in the system when opening or disconnecting components may cause components to be thrown or lubricant to spray, causing injury to people or damage to the environment.

7.1 Malfunctions

In case of a malfunction:

- Check the air pressure and the condition of the air lines.
- Check that the grease filter and the hydraulic lines connected to the pump outlet are not clogged.
- If the problem persists, contact your Oy SKF Ab representative.

7.2 Troubleshooting table

Table 4

Fault table

Description of malfunction	Cause of malfunction	Remedy
The pump does not start	Pressurised air has been cut off.	Turn on the air supply and set the pressure to 2–4.5 bar
	Insufficient air pressure.	Check that the pressure at the pressure air regulator is 2–4.5 bar. Check the pressure air supply hoses for Leaks
The pump is activated, but stops shortly.	Insufficient air pressure.	Check that the pressure at the pressure air regulator is 2–4.5 bar. Check the pressure air supply hoses for Leaks
The pump starts but pressure does not increase.	The grease filter is clogged.	Clean or replace the grease filter cartridge.
	There is air in the suction piping.	Bleed the pump of air by opening the pump's pressure connection (P). Check that only grease and no air comes out of the bleed screw or the pressure connection.
	There are impurities in the pump's suction inlet.	Contact the Oy SKF Ab representative.

8. Technical information

Table 5

General technical data

Max pressure	300 bar
Pressure ratio	1:65 bar
Ambient temperature	-10 °C to +55 °C
Pumping capacity	850 g/min
Pump output per stroke	5.5 g/stroke
Pressure air supply	2 to 4.5 bar
Max. air consumption	300 l/min
Maximum oil viscosity	10 000 cSt
Max noise level	<80 dB
Weight	
1/8 pump	6,3 kg
1/4 pump	7.6 kg
1/1 pump	8.8 kg
Pump pipe diameter	Ø 50 mm
Body material	Aluminium
Dimensions	
1/8 pump	650 x 130 x 130 mm (h x l x w)
1/4 pump	920 x 130 x 130
1/1 pump	1,120 x 130 x 130
Approved lubricants	Lubrication greases from NLGI 000 up to NLGI 2
Degrees of protection	IP65

8.1 Pump output curve

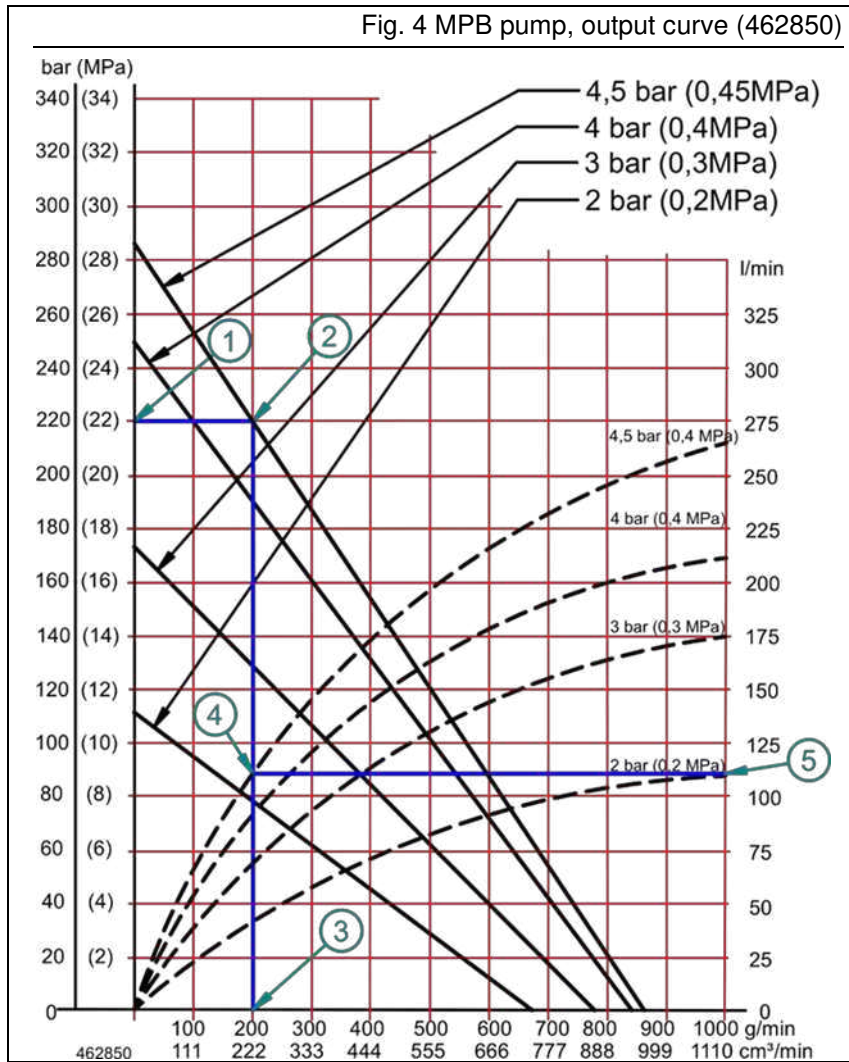

Unit	Description
bar (MPa)	Lubricant counter pressure
g/min cc/min	Pump output
l/min	Pump air consumption

Example:

Air supply pressure is 4.5 bar (item 1) and counter pressure (item 2) is 220 bar, which gives a lubricant output of 200 g/min (item 3). To determine the air consumption, follow the 4.5 bar dashed line to item 4 and draw a horizontal line to the air consumption scale (item 5; 110 l/min).

8.2 MPB pump configurations

Different lid sets (see table 9) allow the MPB pump to be installed in a stationary (STA lid sets) or descending (ECO lid sets) configuration.

NOTE

Use STA lid sets (Figure 6) for pumping NGLI 00 and 0 greases.

Use ECO lid sets (Figure 5) for pumping NLGI 1 and 2 greases.

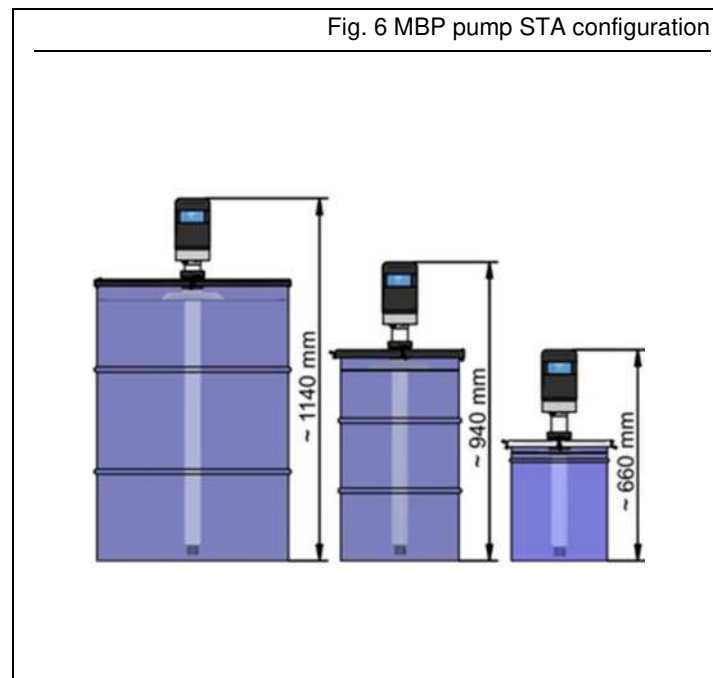
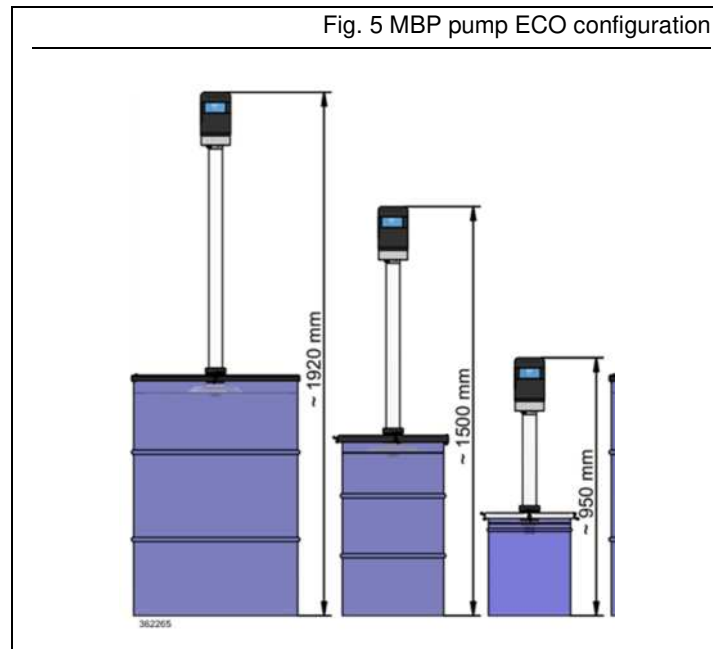

8.3 Designation and order codes

Table 6

MPB-PUMP, designation		
MPB-PUMP-A	Abbreviation	Description
MPB-PUMP:	MPB-PUMP	MPB Pneumatic Barrel Pump
A:	1/8	Lubricant barrel capacity: 18 kg
	1/4	Lubricant barrel capacity: 50 kg
	1/1	Lubricant barrel capacity: 180 kg

Example:

SKF MPB-PUMP-1/1

Lubricant barrel size 1/1 = 180 kg

SKF Magnetic valve operated Pneumatic Barrel pump

Table 7

Order codes		
Item	Order code	Prodmast code
Pumps		
MPB-PUMP-1/1	12381700	VGBN 12381700
MPB-PUMP-1/4	12381701	VGBN 12381701
MPB-PUMP-1/8	12381702	VGBN 12381702
Lid sets		
MAXV2-LIDSET-1/1-ECO-MPB	12381381	VGBV 12381381
MAXV2-LIDSET-1/4-ECO-MPB	12381382	VGBV 12381382
MAXV2-LIDSET-1/8-ECO-MPB	12381383	VGBV 12381383
MAXV2-LIDSET-1/1-STA-MPB	12381384	VGBV 12381384
MAXV2-LIDSET-1/4-STA-MPB	12381385	VGBV 12381385
MAXV2-LIDSET-1/8-STA-MPB	12381386	VGBV 12381386
Pressure air regulator		
MAX-V2-SET-MPBP	12382666	VGBV 12382666

9. Shutdown, decommissioning and storage

9.1 Temporary shutdown

The system can be temporarily shut down by disconnecting it from electrical, pressurised air and hydraulic outlets. If you wish to shut down the product temporarily, see also Section *Storage*. For further information, please refer to relevant components' operating and service manuals in Section *General description*. When recommissioning the equipment, please refer to sections *Commissioning* and *Technical specification* in the relevant components' operating and service manuals.

9.2 Final decommissioning

Used equipment filled with lubricant must be decommissioned and disposed of in accordance with national legislation and the procedures indicated in this operating and service manual.

NOTICE

Lubricants can contain chemicals that can contaminate the soil and the water system. Lubricants must be disposed of appropriately. Observe any local laws and regulations concerning disposal and recycling.

You can also return the product to Oy SKF Ab for disposal. Oy SKF Ab reserves the right to recover any costs arising from the disposal.

9.3 Storage

The products must be stored as follows:

- Store in a dry, dust-free and well-ventilated space.
- Do not store the product for more than 24 months.
- Storage temperature range is +10...40 °C.
- Avoid direct sunlight and heat radiation.
- Store the products clear of the ground or floor.
- Protect the products against impacts, corrosion and dust.

10. Spare parts

Fig. 7

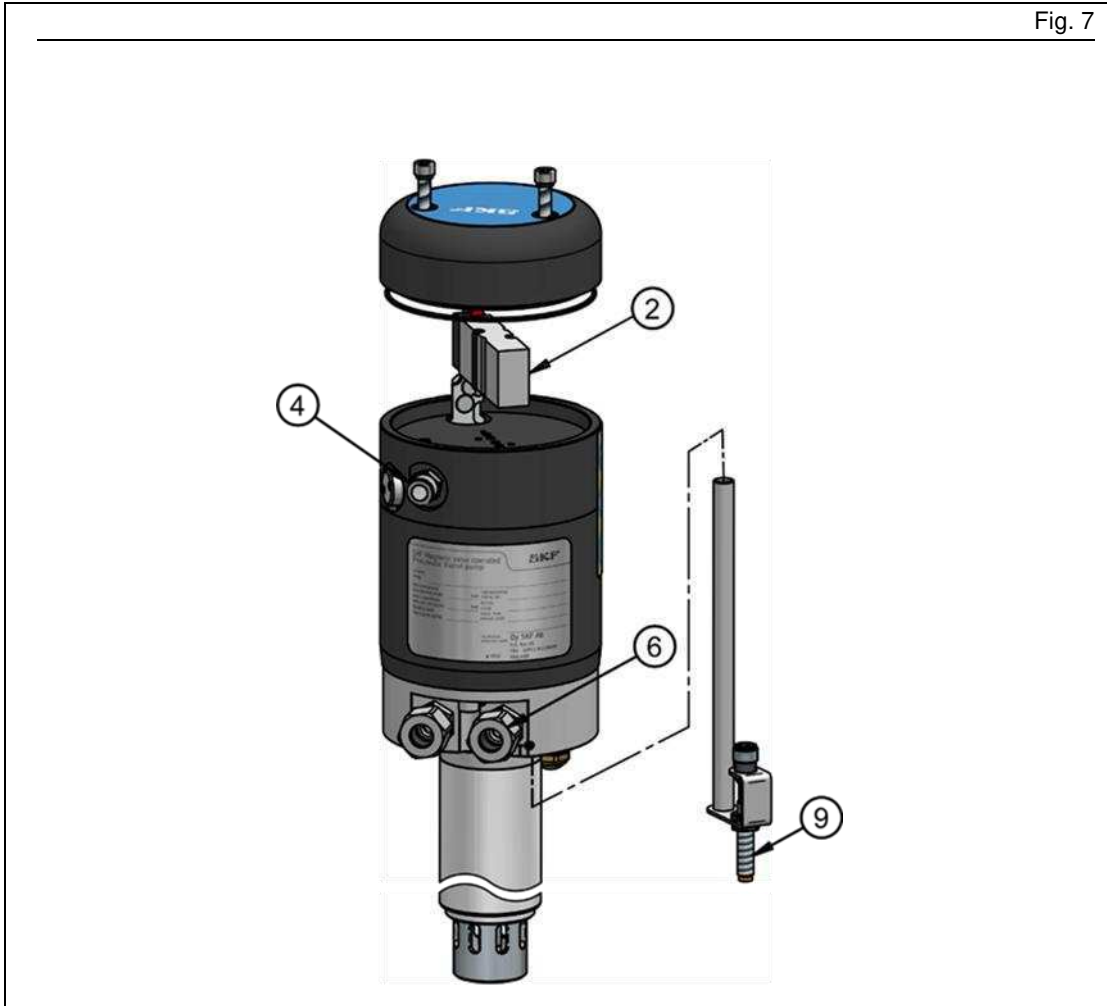

Table 8

MPB-PUMP spare parts

Item	Description	Order code
2:	Valve 6527	12602185
4:	Quick connector 6510	12653165
6:	Basic connector PEL 12L R1/4 H	12805080
9:	Inductive sensor	10543516

11. Pneumatic barrel pump 1:20

11.1 MPB 1:20 pump general description

The purpose of the pump is to supply lubricant to a centralised lubrication system. The pump is suitable for greases up to grade 000-2 (NLGI), and it has both an outlet connection (pressure connection, "P") and a return connection (tank connection, "T"). Its pressure ratio is 1:20, which means that the pump's maximum allowable lubricant pressure (≈ 100 bar, 10 MPa) is achieved at 5 bar air pressure. The minimum air pressure required for operation is 2 bar (0.2 MPa).

SKF-MPB-PUMP is composed of an air motor and a pump unit. The air motor is controlled by a pneumatic valve, which in turn is controlled by a mechanical valve controller. The mechanical valve controller follows the motion of the air motor's air piston. A connecting rod transmits the motion of the air piston to the pump unit's piston assembly, which pressurises the lubricant. The air motor has been designed to be lubrication-free, which means that no lubricator is needed in the air filter regulator assembly.

The pump is intended for central lubrication systems consisting of a pump and lid set, air filter regulator and lubrication system control unit (each sold separately). Installing the MPB pump in an existing system driven by an SKF-EPB pump requires an additional installation kit, which includes the components required for connecting the pump in the lubrication system.

NOTICE

The pump is intended for intermittent use only. If the pump is used continuously at high pressure, or moist pressurized air is used, the pneumatic valve may freeze, causing a malfunction.

11.2 Commissioning

The pump is activated when air (minimum pressure: 2 bar) is supplied to its pressurised air inlet (4). The pump pressurises the lubricant, transferring it through the lubricant outlet (5) into the lubrication system. The pump also includes a tank connection (6). During depressurisation, lubricant returns through the tank connection into the pump pipe and, from there, back to the lubricant barrel. Lubricant pressure can be adjusted from the pressure air regulator (sold separately). When used in a central lubrication system, the pump's air supply is controlled by a control centre (sold separately) following user-defined lubrication values.

The pump can be equipped with a low lubricant level alarm (sold separately), which is connected to the lubrication system's control centre.

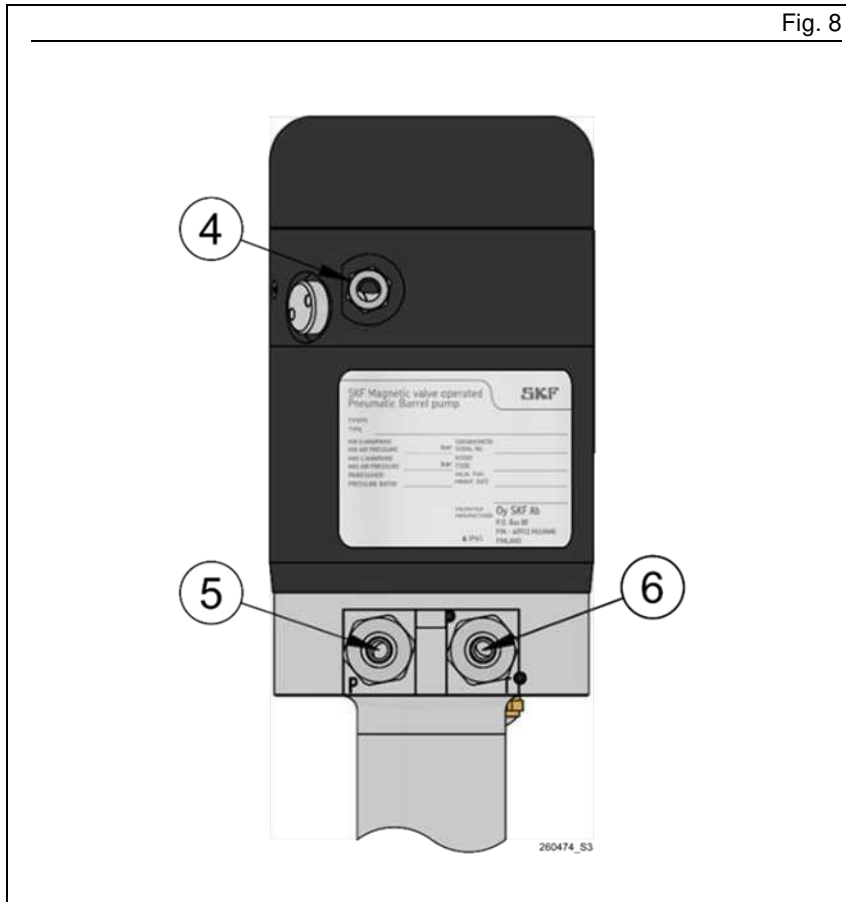

Pressurised air inlet (4)

- Quick connector, 8 mm, G1/4"

Hydraulic connections (5, 6):

- (5), P = Pressure, lubricant outlet, G1/4", basic connector, 12 L
- (6), T = Tank, lubricant inlet, G1/4", basic connector, 12 L

11.3 Main components

MPB pump consists of the following components (Figure 2):

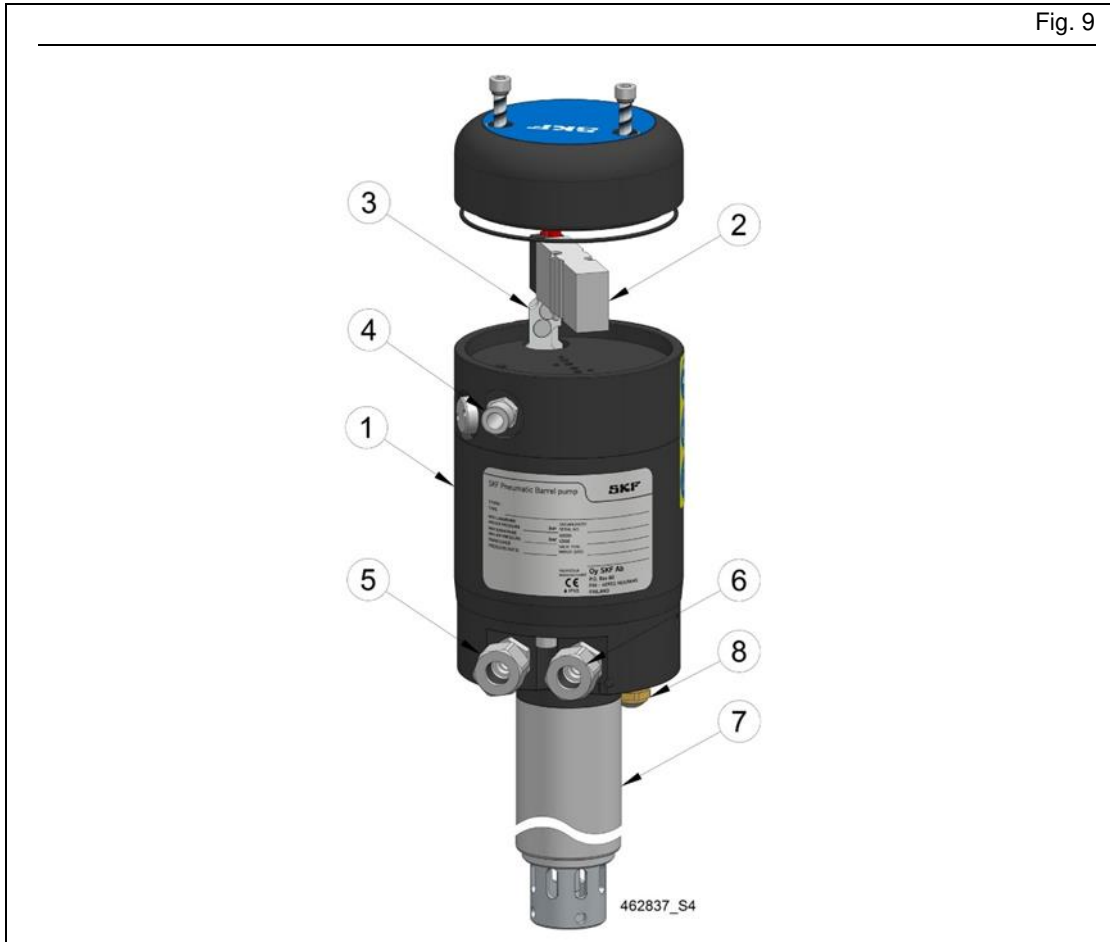

Table 9

Components

Item	Description
1	Air motor
2	Pneumatic valve
3	Valve controller
4	Pressurised air inlet, G1/4", Ø8 quick connector
5	Pressure connection (hydraulic outlet), G1/4", basic connector, 12L
6	Tank connection (return inlet), G1/4", basic connector, 12L
7	Pump unit
8	Air exhaust muffler

11.4 Technical specifications of MPB 1:20

Table 10

General technical data

Max pressure	100 bar
Pressure ratio	1:20 bar
Ambient temperature	-10 °C to +55 °C
Pumping capacity	1900 g/min
Pump output per stroke	11 g/stroke
Pressure air supply	2-5 bar
Max. air consumption	300 l/min
Maximum oil viscosity	5000 cSt
Max noise level	<80 dB
Weight	
1/1 pump	8.8 kg
Pump pipe diameter	Ø 50 mm
Body material	Aluminium
Dimensions	
1/1 pump	1,120 x 130 x 130 mm (h x l x w)
Approved lubricants	Lubrication greases from NLGI 000 up to NLGI 2
Degrees of protection	IP65

11.5 Output curve of MPB 1:20

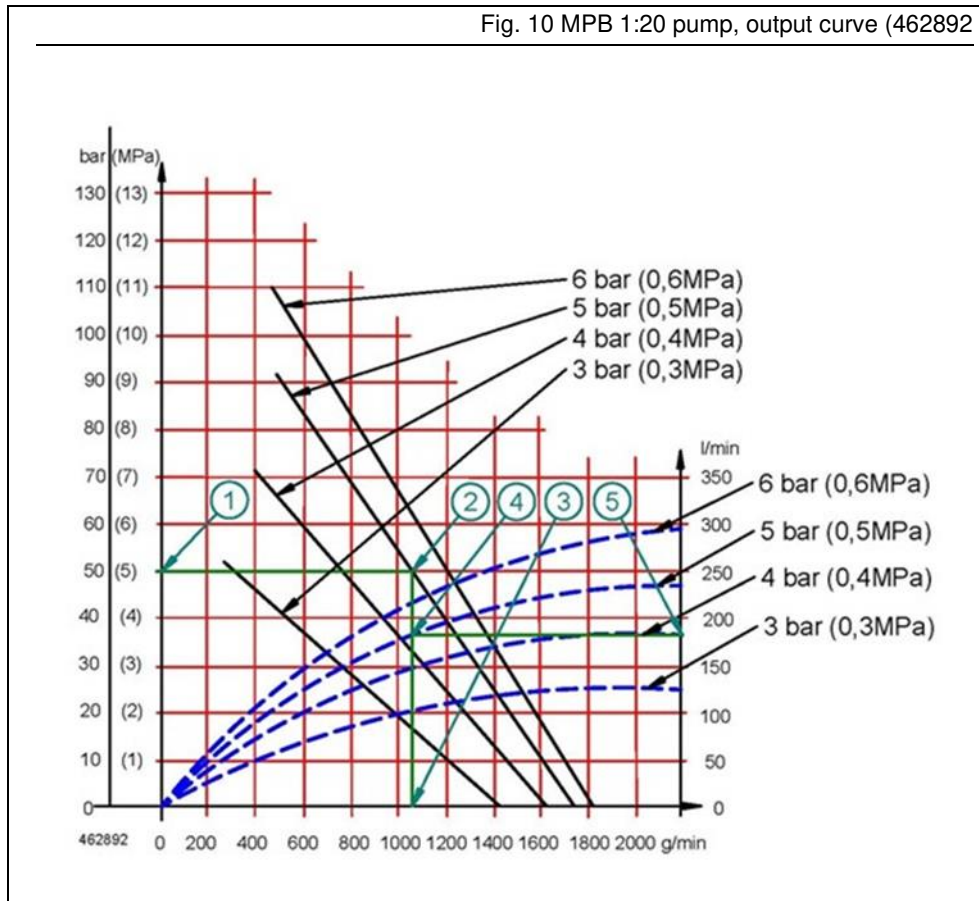

Unit	Description
bar (MPa)	Lubricant counter pressure
g/min cc/min	Pump output
l/min	Pump air consumption

Example:

Air supply pressure is 5 bar (item 1) and counter pressure (item 2) is 50 bar, which gives a lubricant output of 1,050 g/min (item 3). To determine the air consumption, follow the 5 bar dashed line to item 4 and draw a horizontal line to the air consumption scale (item 5; 180 l/min).

11.6 Designation and order codes

Table 11		
MPB-PUMP, designation		
MPB-20:1-PUMP-A-B	Abbreviation	Description
MPB-PUMP:	MPB-PUMP	MPB Pneumatic Barrel Pump
A:	1/1	Lubricant barrel capacity: 180 kg
B:	1:20	

Example:

SKF MPB-PUMP-1/1-1:20

Pressure ratio: 1:20

Lubricant barrel size 1/1 = 180 kg

SKF Magnetic valve operated Pneumatic Barrel pump

Table 12		
Order codes		
Item	Order code	Prodmast code
Pumps		
MPB-PUMP-1/1-1:20	12381703	VGBN 12381703
Lid sets		
MAX-LIDSET-1/1-STA-MPBP	12381328	VGBV 12381328
Pressure air regulator		
MAX-V2-SET-MPBP	12382666	VGBV 12382666

11.7 Spare parts MPB 1:20

Fig. 11



Table 13

MPB-PUMP spare parts

Item	Description	Order code
2:	Valve 6527	12602185
4:	Quick connector 6510	12653165
5/6	Basic connector PEL 12L R1/4 H	12805080

12. Appendix

12.1 China RoHS Table

Table 14

部件名称 (Part Name)	有毒有害物质或元素 (Hazardous substances)					
	铅	汞	镉	六价铬	多溴联苯	多溴二苯醚
	Lead (Pb)	Mercury (Hg)	Cadmium (Cd)	Hexavalent Chromium (Cr(VI))	Polybrominated biphenyls (PBB)	Polybrominated diphenyl ethers (PBDE)
用钢和黄铜加工的零件 (Components made of machining steel and brass)	X	0	0	0	0	0
本表格依据SJ/T11364的规定编制 (This table is prepared in accordance with the provisions of SJ/T 11364.)						
0 :	表示该有毒有害物质在该部件所有均质材料中的含量均在GB/T 26572 规定的限量要求以下。 (Indicates that said hazardous substance contained in all of the homogeneous materials for this part is below the limit requirement of GB/T 26572.)					
X :	表示该有毒有害物质至少在该部件的某一均质材料中的含量超出GB/T 26572标准规定的限量要求。 (Indicates that said hazardous substance contained in at least one of the homogeneous materials used for this part is above the limit requirement of GB/T 26572.)					