

SKF double direction angular contact thrust ball bearings for screw drives

– SKF BEAM / BEAS series



Higher speed and dynamic load. Lower vibration and friction.

The double direction angular contact thrust ball bearings from SKF have been developed for machine tool applications where space is tight and easy mounting is required. Optimized for increased load capacity and speed, these ready-to-mount bearings are available in two series:

- Double direction bearings in the BEAS series, for shaft diameters from 8 to 30 mm
- Double direction bearings for bolt mounting in the BEAM series, for shaft diameters from 12 to 60 mm

Ball screws are high-accuracy and high-efficiency mechanical devices widely used to drive the axis of a machine tool. They are, in most cases, supported at both ends by ball screw support bearings specially designed for the specific requirements of this application. SKF BEAM/BEAS bearings thus

New generation of SKF BEAM/BEAS:

- Optimized design of the internal geometry
- New ball-centered cage made of glass-fibre reinforced polyamide
- New RSH seal with optimized axial contact
- Increased number of holes for easier mounting

provide the appropriate level of axial stiffness and load carrying capacity, while also accommodating high accelerations. SKF double direction angular contact thrust ball bearings are beneficial in all applications where secure radial and axial support is required.

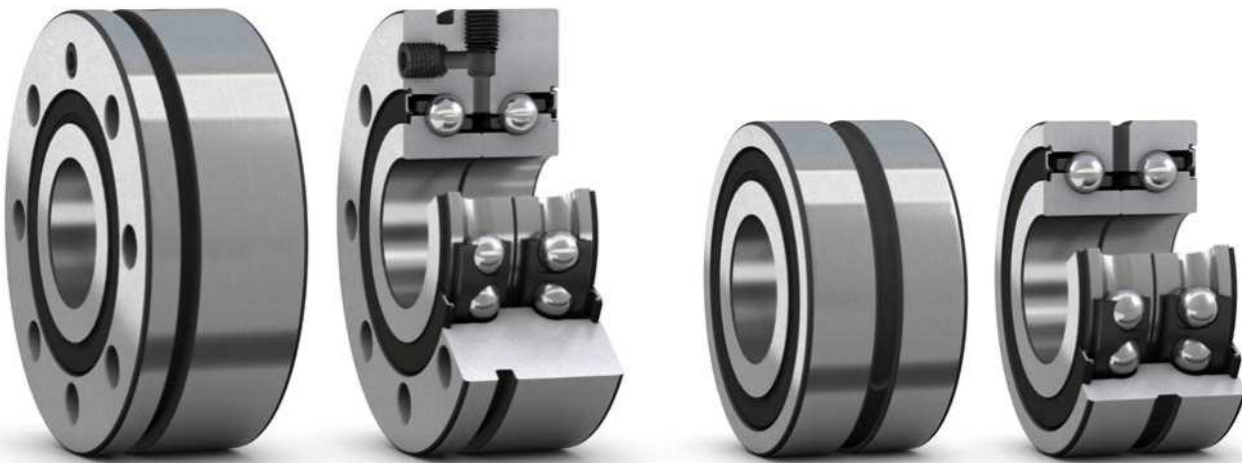

Double direction angular contact thrust ball bearings, BEAM series

Double direction angular contact thrust ball bearings, BEAS series

Added value for customers

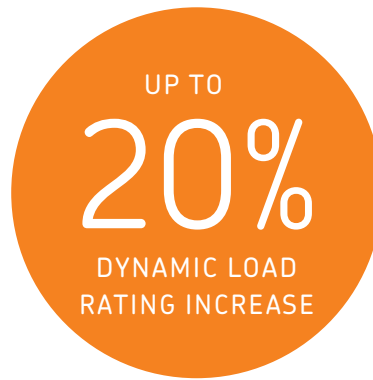

With SKF BEAM/BEAS work can be completed faster – by virtue of higher speed limit and load rating. Maintenance intervals may also be extended due to improved sealing and lower friction design.

Improved technical bearing values

There is significant improvement in the dynamic and static load ratings of the SKF new generation BEAM/BEAS compared to the previous generation. Thanks to the optimized internal geometry of the bearing, the dynamic load capacity has been increased by up to 20% for the BEAM range, and up to 17% for the BEAS range. The new design also allows for an increase of the speed limit by up to 15% for BEAM and up to 35% for BEAS – depending on the bearing size – compared to previous generation values. The “closed” design of the cage is more suitable for high speed.

New low contact seals and cages

SKF new generation BEAM and BEAS are sealed and greased as standard. Lower bearing friction means not only lower energy consumption and longer grease/bearing life but also lower temperature increase. This reduces thermal deformation of the customer’s machine structure – resulting in better

machining precision. What’s more, the new glass-fibre reinforced polyamide cage is centered on the balls to considerably reduce the risk of vibration.

The new low contact seal design minimizes friction while improving the sealing performance – contributing to longer bearing life. Comparative tests with products on the market have shown that the new seal design can be up to 7% more effective against dust contamination.

Reducing cost of ownership

The new generation of SKF BEAM/BEAS helps to reduce your total cost of ownership through:

- **improved efficiency:** increased loading capacity and speed limit help to reduce machining operation time
- **energy savings:** lower friction contributes to reduce energy consumption
- **increased uptime:** lower friction and improved sealing capacity also lead to longer bearing life – which in turn contributes to longer maintenance time intervals
- **reduced downtime:** faster assembly and replacement help to reduce machine downtime
- **interchangeable design:** the new features do not affect interchangeability

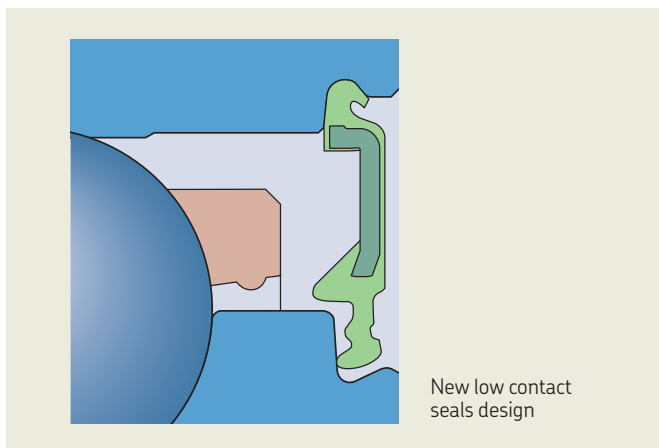

New cage design

Increase of speed limit SKF BEAM series

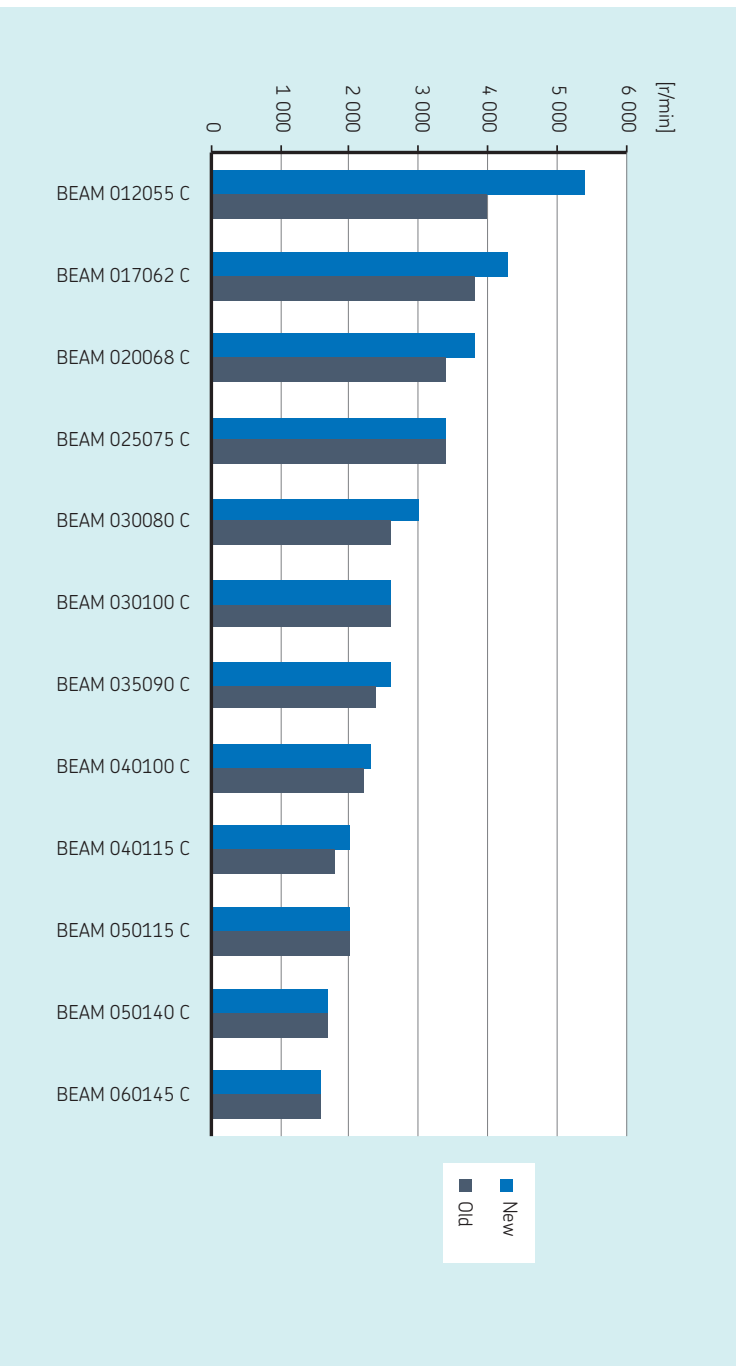

Increase of speed limit SKF BEAS series

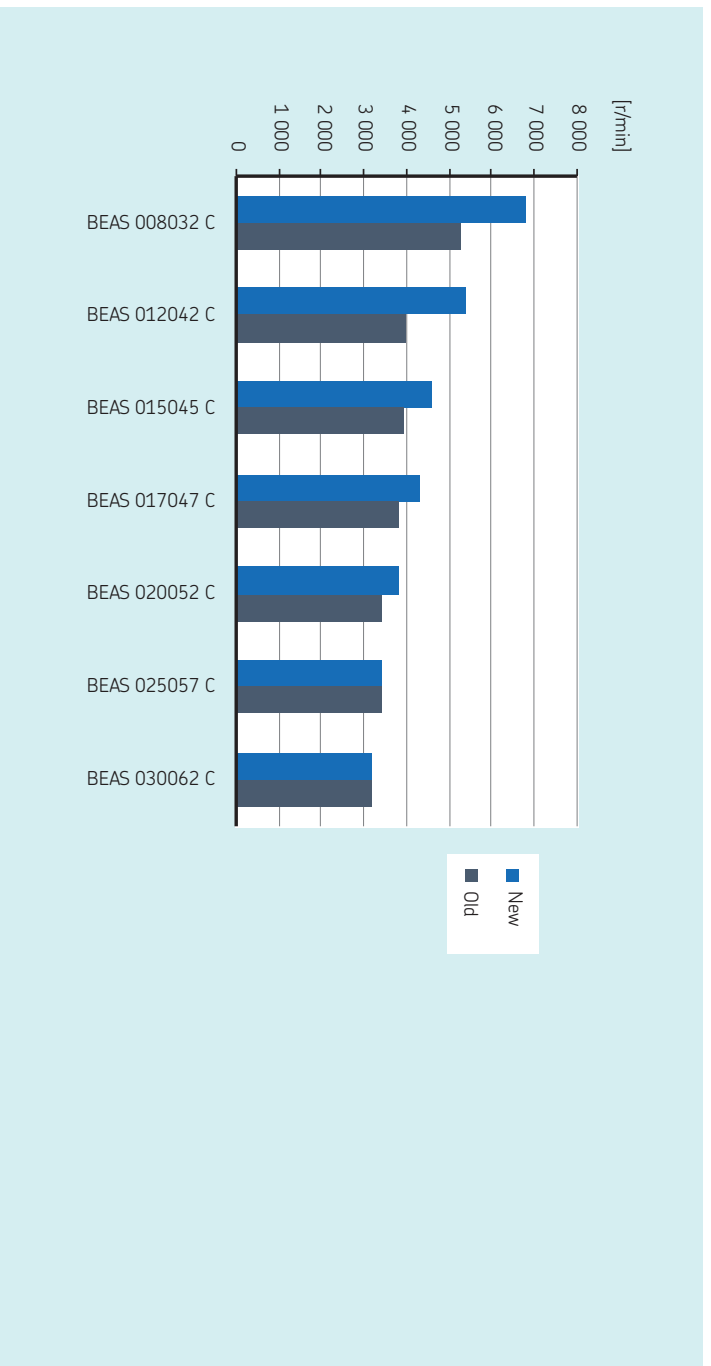

Increase of load rating and life SKF BEAM series

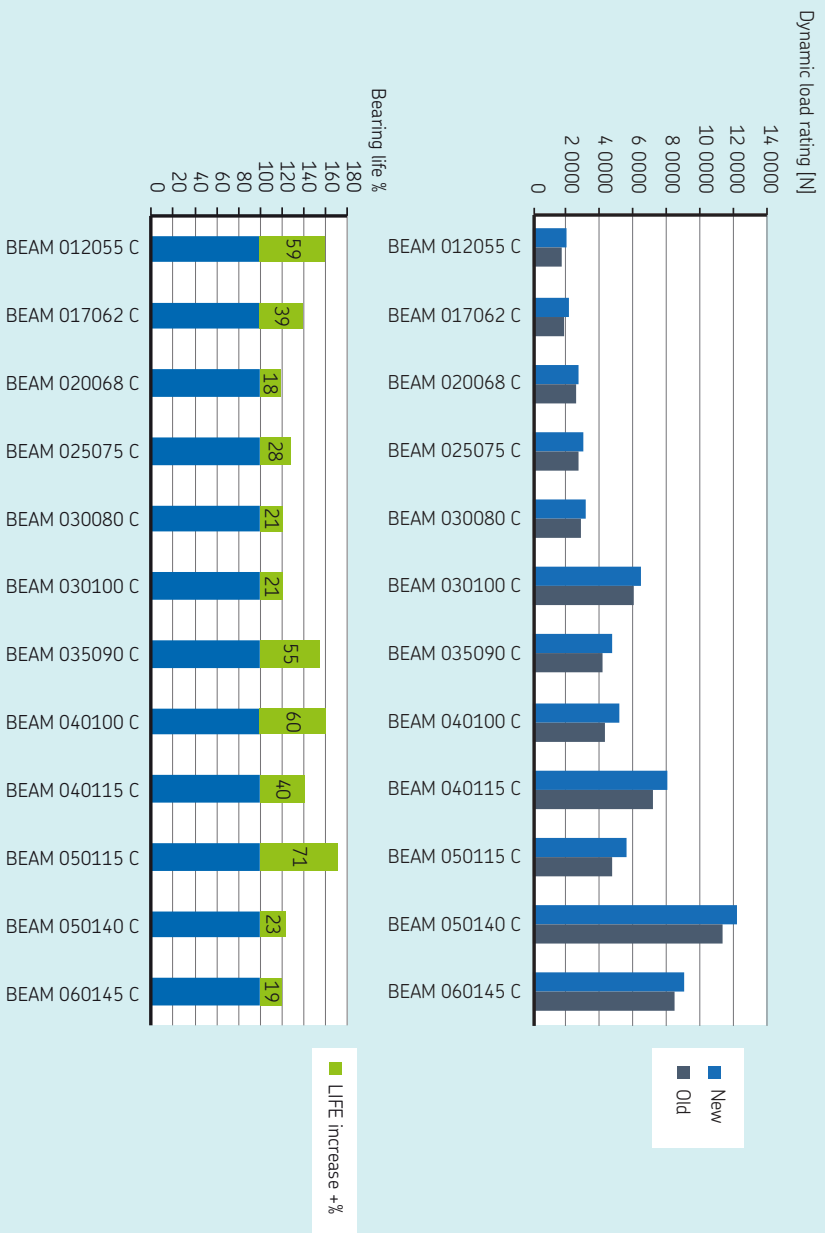

Increase of load rating and life SKF BEAS series

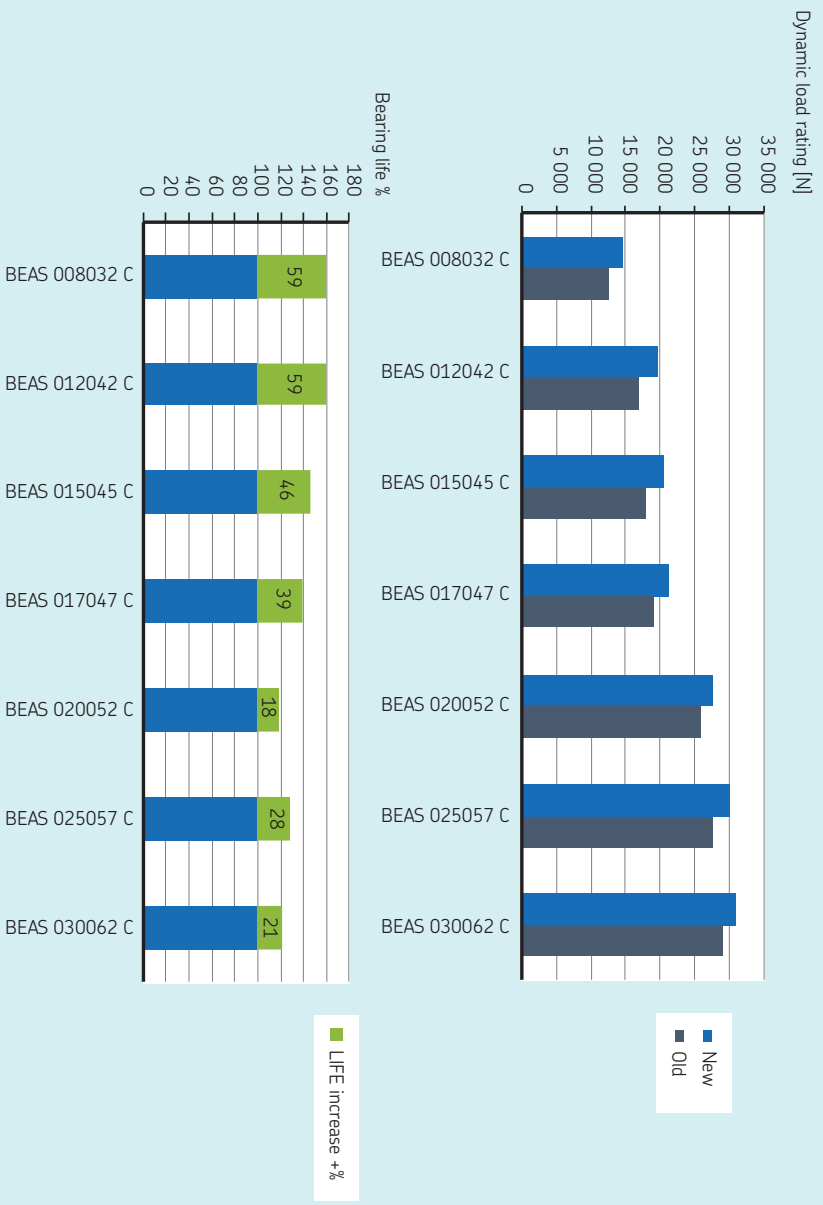

Standard execution

Tolerance of angular contact thrust ball bearings for screw drives

Inner ring and bearing height		Double direction bearings				
d over	incl.	Δ_{ds} high	Δ_{dmp} low	Δ_{Bs} high	low	S_{ia} max
mm		μm		μm		μm
8	10	0	-5	0	-250	2
10	18	0	-5	0	-250	2
18	25	0	-5	0	-250	2
25	30	0	-5	0	-250	2,5
30	50	0	-5	0	-250	2,5
50	80	0	-8	0	-250	3

Outer ring		Double direction bearings			
D over	incl.	Δ_{Ds} high	Δ_{Dmp} low	Δ_{Cs} high	low
mm		μm		μm	
30	50	0	-10	0	-250
50	80	0	-10	0	-250
80	110	0	-10	0	-250
110	140	0	-10	0	-250
140	150	0	-15	0	-250

PE execution

Tolerance of angular contact thrust ball bearings for screw drives

Inner ring and bearing height		Double direction bearings				
d over	incl.	Δ_{ds} high	Δ_{dmp} low	Δ_{Bs} high	low	S_{ia} max
mm		μm		μm		μm
8	10	0	-8	0	-250	5
10	18	0	-10	0	-250	5
18	25	0	-10	0	-250	5
25	30	0	-10	0	-250	5
30	60	0	-10	0	-250	5

Outer ring		Double direction bearings			
D over	incl.	Δ_{Ds} high	Δ_{Dmp} low	Δ_{Cs} high	low
mm		μm		μm	
30	50	0	-11	0	-250
50	80	0	-13	0	-250
80	120	0	-15	0	-250

Axial preload

Axial preload, frictional moment

Designation	Axial preload	Frictional moment ¹⁾
–	N	Nm
BEAS 008032 C	300	0,08
BEAS 010034 C	410	0,12
BEAS 012042 C	650	0,16
BEAS 015045 C	650	0,2
BEAS 017047 C	720	0,24
BEAS 020052 C	1 650	0,3
BEAS 025057 C	1 920	0,4
BEAS 030062 C	2 250	0,5
BEAM 012055 C	650	0,16
BEAM 015060 C	650	0,2
BEAM 017062 C	720	0,24
BEAM 020068 C	1 650	0,3
BEAM 025075 C	1 920	0,4
BEAM 030080 C	2 250	0,5
BEAM 030100 C	3 710	0,8
BEAM 035090 C	2 750	0,6
BEAM 040100 C	3 460	0,7
BEAM 040115 C	4 890	1,3
BEAM 050115 C	3 930	0,9
BEAM 050140 C	6 750	2,6
BEAM 060145 C	4 100	2

¹⁾ The guideline values for the frictional moment apply to bearings with contact seals (designation suffix 2RSH). For bearings with non-contact seals (designation suffix 2RSL), the frictional moment is only half.

Axial and tilting stiffness

Axial and tilting stiffness

Designation	Axial stiffness ²⁾	Tilting stiffness ²⁾
–	N/ μm	Nm/mrad
BEAS 008032 C	270	20
BEAS 010034 C	330	25
BEAS 012042 C	400	50
BEAS 015045 C	430	65
BEAS 017047 C	470	80
BEAS 020052 C	680	140
BEAS 025057 C	790	200
BEAS 030062 C	900	290
BEAM 012055 C	400	50
BEAM 015060 C	430	65
BEAM 017062 C	470	80
BEAM 020068 C	680	140
BEAM 025075 C	790	200
BEAM 030080 C	900	290
BEAM 030100 C	940	400
BEAM 035090 C	930	400
BEAM 040100 C	1 100	550
BEAM 040115 C	1 240	880
BEAM 050115 C	1 340	970
BEAM 050140 C	1 480	1 530
BEAM 060145 C	1 380	1 520

²⁾ The values are valid for unmounted bearings.

Designation system

Examples: BEAM 030080 C -2RSH / PE

BEAM 030080 C -2RSH / PE

Bearing series

BEAM Double direction bearing for bolt mounting
BEAS Double direction bearing

Bearing size

008032 8 mm bore diameter and 32 outside diameter
to
060145 60 mm bore diameter and 145 outside diameter

Design features

C Improved internal design

Sealing solutions

-2RSH Contact seal on both sides, NBR
-2RSL Non-contact seal on both sides, NBR

Tolerance class

- Super precision tolerance class

/ PE Less stringent tolerance class

Markings on bearings

The BEAM and BEAS bearings have various markings on the side faces of the rings (→ **fig. 1**).

1. SKF trademark
2. Complete designation of the bearing/unit
3. Country of manufacture
4. Date of manufacture, coded

Previously, the marking was on the outer ring outside surface. Now, the laser marking is placed on the side face of the outer ring. This is the bearing side usually visible on the machine tool, which means that the bearing designation is easily read without dismounting it.

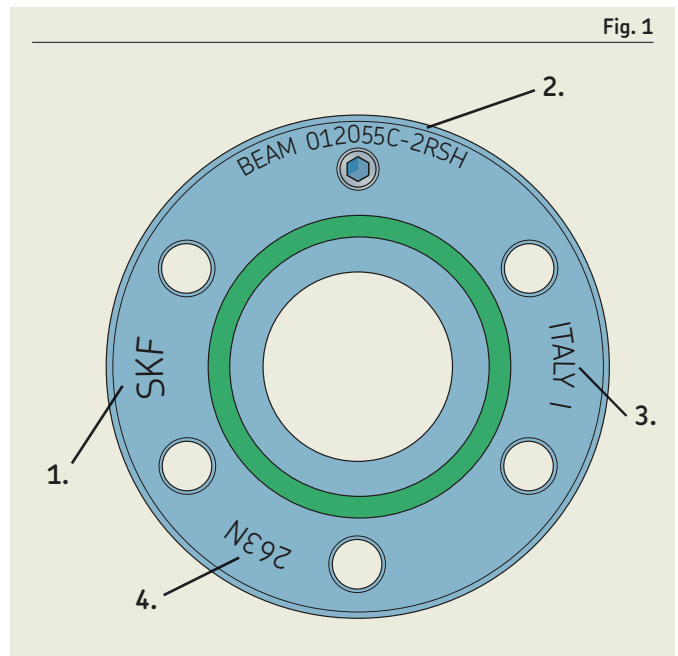

Double direction angular contact thrust ball bearings for screw drives, BEAM series

d 12-60 mm

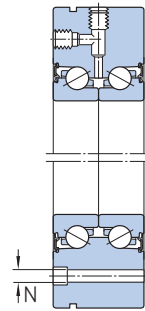
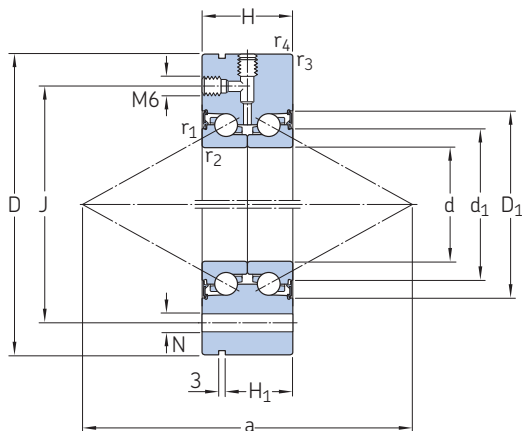

BEAM 060145 C

Principal dimensions			Basic load rating		Fatigue load limit	Attainable speed	Mass	Designation
d	D	H	dynamic C	static C ₀	P _u			
mm			kN		kN	r/min	kg	–
12	55	25	19,6	30	1,1	5 400	0,35	BEAM 012055 C-2RSH
	55	25	19,6	30	1,1	9 000	0,35	BEAM 012055 C-2RSL
15	60	25	20,4	33,5	1,3	4 600	0,42	BEAM 015060 C-2RSH
	60	25	20,4	33,5	1,3	7 700	0,42	BEAM 015060 C-2RSL
17	62	25	21,2	37,5	1,4	4 300	0,45	BEAM 017062 C-2RSH
	62	25	21,2	37,5	1,4	7 200	0,45	BEAM 017062 C-2RSL
20	68	28	27,5	51	1,9	3 800	0,58	BEAM 020068 C-2RSH
	68	28	27,5	51	1,9	6 400	0,58	BEAM 020068 C-2RSL
25	75	28	30	60	2,2	3 400	0,7	BEAM 025075 C-2RSH
	75	28	30	60	2,2	5 600	0,7	BEAM 025075 C-2RSL
30	80	28	31	69,5	2,6	3 000	0,75	BEAM 030080 C-2RSH
	80	28	31	69,5	2,6	4 900	0,75	BEAM 030080 C-2RSL
	100	38	64	118	4,3	2 600	1,72	BEAM 030100 C-2RSH
	100	38	64	118	4,3	4 300	1,72	BEAM 030100 C-2RSL
35	90	34	47,5	98	3,7	2 600	1,13	BEAM 035090 C-2RSH
	90	34	47,5	98	3,7	4 300	1,13	BEAM 035090 C-2RSL
40	100	34	51	114	4,3	2 300	1,43	BEAM 040100 C-2RSH
	100	34	51	114	4,3	3 900	1,43	BEAM 040100 C-2RSL
	115	46	80	176	6,4	2 000	2,6	BEAM 040115 C-2RSH
	115	46	80	176	6,4	3 400	2,6	BEAM 040115 C-2RSL
50	115	34	56	146	5,4	2 000	1,8	BEAM 050115 C-2RSH
	115	34	56	146	5,4	3 600	1,8	BEAM 050115 C-2RSL
	140	54	122	270	10	1 700	4,5	BEAM 050140 C-2RSH
	140	54	122	270	10	2 800	4,5	BEAM 050140 C-2RSL
60	145	45	90	232	8,7	1 600	4,1	BEAM 060145 C-2RSH
	145	45	90	232	8,7	3 000	4,1	BEAM 060145 C-2RSL

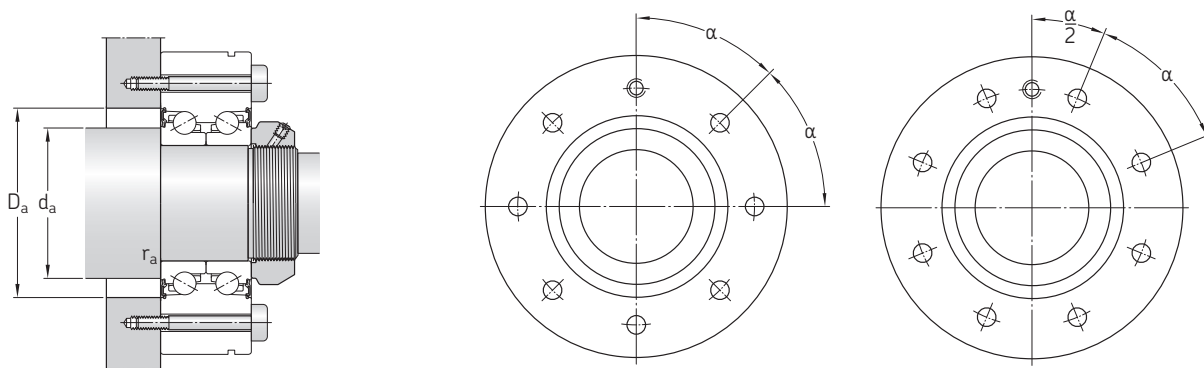

BEAM 030100 C
 BEAM 040115 C
 BEAM 050140 C
 BEAM 060145 C

Dimensions							Abutment and fillet dimensions			Holes for attachment bolts in accordance with DIN 912			
d	d ₁	D ₁	H ₁	r _{1,2} min.	r _{3,4} min.	a	d _a min.	D _a max.	r _a max.	Size	Dimensions		Pitch
mm	~	~	~				mm			–	J	N	nr. x α [°]
mm							mm			–	mm		–
12	22,7	32,1	17	0,3	0,6	55	16	33	0,3	M6	42	6,8	5×60°
	22,7	32,1	17	0,3	0,6	55	16	33	0,3	M6	42	6,8	5×60°
15	26,7	36,1	17	0,3	0,6	62	20	35	0,3	M6	46	6,8	5×60°
	26,7	36,1	17	0,3	0,6	62	20	35	0,3	M6	46	6,8	5×60°
17	28,7	38,1	17	0,3	0,6	65	23	37	0,3	M6	48	6,8	5×60°
	28,7	38,1	17	0,3	0,6	65	23	37	0,3	M6	48	6,8	5×60°
20	32,2	43,2	19	0,3	0,6	73	25	43	0,3	M6	53	6,8	7×45°
	32,2	43,2	19	0,3	0,6	73	25	43	0,3	M6	53	6,8	7×45°
25	37,2	48,2	19	0,3	0,6	82	32	48	0,3	M6	58	6,8	7×45°
	37,2	48,2	19	0,3	0,6	82	32	48	0,3	M6	58	6,8	7×45°
30	42,3	53,2	19	0,3	0,6	90	40	53	0,3	M6	63	6,8	11×30°
	42,3	53,2	19	0,3	0,6	90	40	53	0,3	M6	63	6,8	11×30°
	48,7	64,7	30	0,3	0,6	105	47	64	0,3	M8	80	8,8	8×45°
	48,7	64,7	30	0,3	0,6	105	47	64	0,3	M8	80	8,8	8×45°
35	49,2	62,7	25	0,3	0,6	105	45	62	0,3	M8	75	8,8	7×45°
	49,2	62,7	25	0,3	0,6	105	45	62	0,3	M8	75	8,8	7×45°
40	54,2	67,8	25	0,3	0,6	114	50	67	0,3	M8	80	8,8	7×45°
	54,2	67,8	25	0,3	0,6	114	50	67	0,3	M8	80	8,8	7×45°
	62,1	80	36	0,6	0,6	135	56	80	0,6	M8	94	8,8	12×30°
	62,1	80	36	0,6	0,6	135	56	80	0,6	M8	94	8,8	12×30°
50	67,7	81,3	25	0,3	0,6	137	63	82	0,3	M8	94	8,8	11×30°
	67,7	81,3	25	0,3	0,6	137	63	82	0,3	M8	94	8,8	11×30°
	76,1	97,1	45	0,6	0,6	163	63	98	0,6	M10	113	11	12×30°
	76,1	97,1	45	0,6	0,6	163	63	98	0,6	M10	113	11	12×30°
60	82,1	100	35	0,6	0,6	169	82	100	0,6	M8	120	8,8	8×45°
	82,1	100	35	0,6	0,6	169	82	100	0,6	M8	120	8,8	8×45°

Double direction angular contact thrust ball bearings for screw drives, BEAS series

d 8-30 mm

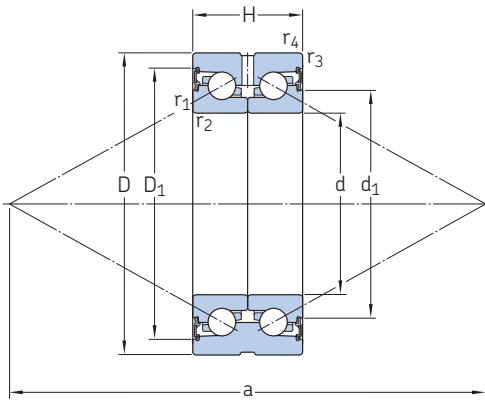

Principal dimensions			Basic load rating		Fatigue load limit	Attainable speed	Mass	Designation
d	D	H	dynamic C	static C ₀	P _u			
mm			kN		kN	r/min	kg	–
8	32	20	14,6	20	0,8	6 800	0,09	BEAS 008032 C-2RSH
	32	20	14,6	20	0,8	11 300	0,09	BEAS 008032 C-2RSL
10	34	20	15,3	22,8	0,9	6 000	0,1	BEAS 010034 C-2RSH
	34	20	15,3	22,8	0,9	10 000	0,1	BEAS 010034 C-2RSL
12	42	25	19,6	30	1,1	5 400	0,2	BEAS 012042 C-2RSH
	42	25	19,6	30	1,1	9 000	0,2	BEAS 012042 C-2RSL
15	45	25	20,4	33,5	1,3	4 600	0,22	BEAS 015045 C-2RSH
	45	25	20,4	33,5	1,3	7 700	0,22	BEAS 015045 C-2RSL
17	47	25	21,2	37,5	1,4	4 300	0,24	BEAS 017047 C-2RSH
	47	25	21,2	37,5	1,4	7 200	0,24	BEAS 017047 C-2RSL
20	52	28	27,5	51	1,9	3 800	0,32	BEAS 020052 C-2RSH
	52	28	27,5	51	1,9	6 400	0,32	BEAS 020052 C-2RSL
25	57	28	30	60	2,2	3 400	0,36	BEAS 025057 C-2RSH
	57	28	30	60	2,2	5 600	0,36	BEAS 025057 C-2RSL
30	62	28	31	69,5	2,6	3 200	0,41	BEAS 030062 C-2RSH
	62	28	31	69,5	2,6	5 300	0,41	BEAS 030062 C-2RSL

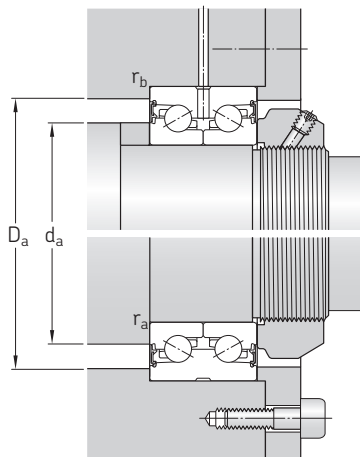

Dimensions						Abutment and fillet dimensions			
d	d ₁ ~	D ₁ ~	r _{1,2} min.	r _{3,4} min.	a	d _a min.	D _a max.	r _a max.	r _b max.
mm						mm			
8	17,7	26,3	0,3	0,6	43	11	26	0,3	0,6
	17,7	26,3	0,3	0,6	43	11	26	0,3	0,6
10	19,7	28,3	0,3	0,6	46	14	28	0,3	0,6
	19,7	28,3	0,3	0,6	46	14	28	0,3	0,6
12	22,7	32,1	0,3	0,6	55	16	33	0,3	0,6
	22,7	32,1	0,3	0,6	55	16	33	0,3	0,6
15	26,7	36,1	0,3	0,6	62	20	35	0,3	0,6
	26,7	36,1	0,3	0,6	62	20	35	0,3	0,6
17	28,7	38,1	0,3	0,6	65	23	37	0,3	0,6
	28,7	38,1	0,3	0,6	65	23	37	0,3	0,6
20	32,2	43,2	0,3	0,6	73	25	43	0,3	0,6
	32,2	43,2	0,3	0,6	73	25	43	0,3	0,6
25	37,2	48,2	0,3	0,6	82	32	48	0,3	0,6
	37,2	48,2	0,3	0,6	82	32	48	0,3	0,6
30	42,3	53,2	0,3	0,6	90	40	53	0,3	0,6
	42,3	53,2	0,3	0,6	90	40	53	0,3	0,6

skf.com

® SKF is a registered trademark of the SKF Group.

© SKF Group 2018

The contents of this publication are the copyright of the publisher and may not be reproduced (even extracts) unless prior written permission is granted. Every care has been taken to ensure the accuracy of the information contained in this publication but no liability can be accepted for any loss or damage whether direct, indirect or consequential arising out of the use of the information contained herein.

PUB BU/P2 17978/1 EN · August 2018