

Progressive metering devices of the SSV, SSV-E, SSVM, SSVD, SSVD-E, SSVL, and SSVDL series

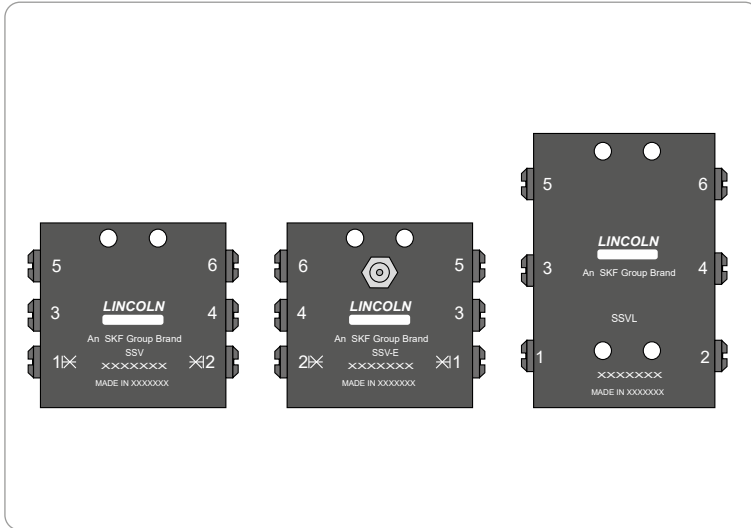

951-171-049-EN

Version 08

26/04/2023

## Legal notice

### Manufacturer

SKF Lubrication Systems Germany GmbH  
e-mail: [Lubrication-germany@skf.com](mailto:Lubrication-germany@skf.com)  
[www.skf.com/lubrication](http://www.skf.com/lubrication)

### Manufacturer's addresses

#### Walldorf Facilities

Heinrich-Hertz-Straße 2-8  
69190 Walldorf  
Germany  
Tel: +49 (0) 6227 33-0  
Fax: +49 (0) 6227 33-259

#### Berlin Facilities

Motzener Straße 35/37  
12277 Berlin  
Germany  
Phone +49 (0)30 72002-0  
Fax +49 (0)30 72002-111  
[www.skf.com/lubrication](http://www.skf.com/lubrication)

### Training courses

In order to provide a maximum of safety and economic viability, SKF carries out detailed training courses. It is recommended that the training courses are attended. For more information please contact the respective SKF Service address.

### Copyright

© Copyright SKF  
All rights reserved.

### Warranty

The instructions do not contain any information on the warranty. This can be found in our general terms and conditions.

### Service address North America

SKF Lubrication Business Unit  
Lincoln Industrial  
5148 North Hanley Road, St. Louis,  
MO. 63134 USA

### Disclaimer

The manufacturer shall not be held responsible for damages caused by:

- Non appropriate use  
faulty assembly, operation, setting, maintenance, repair or accidents
- Use of inappropriate lubricants
- Improper or late response to malfunctions
- Unauthorized modifications of the product
- Intent or negligence
- Use of non-original SKF spare parts
- Faulty planning or layout of the centralized lubrication system

Liability for loss or damage resulting from the use of our products is limited to the maximum purchase price. Liability for consequential damages of whatever kind is excluded.

## Table of contents

























Legal notice .....	2		
Explanation of symbols, signs and abbreviations .....	6		
<b>1. Safety instructions.....</b>	<b>8</b>	2.4	Temperature characteristics.....17
1.1 General safety instructions.....	8	2.5	Ageing of lubricants.....17
1.2 General behaviour when handling the product.....	8	2.6	Solid lubricants in lubrication greases .....
1.3 Intended use.....	9	2.6.1	Chisel pastes.....18
1.4 Foreseeable misuse.....	9		
1.5 Reference on Pressure Equipment Directive 2014/68/EU.....	10	<b>3. Overview, functional description .....</b>	<b>19</b>
1.6 Modifications of the product.....	10	3.1	General information .....
1.7 Inspections prior to delivery .....	10	3.2	Fields of application .....
1.8 Other applicable documents.....	10	3.3	Function monitoring options .....
1.9 Persons authorized to operate the pump .....	11	3.3.1	Visual monitoring with indicator pin.....
1.9.1 Operator.....	11	3.3.2	Electrical monitoring/controlling via proximity switch.....
1.9.2 Specialist in mechanics .....	11	3.3.3	Electrical monitoring/controlling via piston detector .....
1.9.3 Specialist in electrics .....	11	3.3.4	System-related monitoring.....
1.10 Briefing of external technicians.....	11	3.4	Course of the lubricant in the SSV metering device.....
1.11 Provision of personal protective equipment.....	11	3.5	Course of the lubricant in the SSVD metering device.....
1.12 Operation.....	11		
1.13 Emergency stopping.....	11	<b>4. Technical data.....</b>	<b>35</b>
1.14 Transport, installation, maintenance, malfunctions, repair, shutdown, disposal.....	12	4.1	Technical data SSV/SSV-E/SSVM.....
1.15 Initial commissioning / daily start-up.....	13	4.1.1	Construction sizes, dimensions and weights SSV/SSV-E/SSVM ...
1.16 Cleaning .....	13	4.1.2	Tightening torques SSV/SSV-E.....
1.17 Markings and conventions.....	14	4.1.3	Tightening torques SSVM.....
1.18 Residual risks .....	15	4.2	Technical data SSVD/SSVD-E .....
		4.2.1	Construction sizes, dimensions and weights SSVD/SSVD-E.....
		4.2.2	Tightening torques SSVD/SSVD-E .....
<b>2. Lubricants.....</b>	<b>16</b>	4.3	Technical data of the SSVL/SSVDL.....
2.1 General information .....	16	4.3.1	SSVL/SSVDL .....
2.2 Selection of lubricants.....	17	4.4	Tightening torques SSVL, SSVDL .....
2.3 Material compatibility.....	17	4.5	Technical data of the universal piston detector .....

4.6	Technical data proximity switch DC version .....	46	6.7	Optional mounting bracket for SSV, SSV-E, SSVD and SSVD-E.....	58
4.7	Technical data proximity switch AC/DC version .....	47	6.8	Venting of the SSV metering devices and the progressive lubrication system.....	58
4.8	Technical data proximity switch DC version for SSVM .....	48			
4.9	Technical data limit switch .....	49			
<b>5.</b>	<b>Delivery, returns, and storage .....</b>	<b>50</b>	<b>7.</b>	<b>Initial start-up .....</b>	<b>59</b>
5.1	Delivery .....	50	<b>8.</b>	<b>Operation .....</b>	<b>59</b>
5.2	Returns .....	50			
5.3	Storage.....	50	<b>9.</b>	<b>Cleaning .....</b>	<b>60</b>
5.4	Storage temperature range.....	50	9.1	Cleaning agents .....	60
5.5	Storage conditions for parts filled with lubricant.....	51	9.2	Exterior cleaning .....	60
5.5.1	Storage period of up to 6 months.....	51	9.3	Interior cleaning.....	60
5.5.2	Storage period from 6 to 18 months.....	51			
5.5.3	Storage period exceeding 18 months .....	51	<b>10.</b>	<b>Maintenance .....</b>	<b>61</b>
<b>6.</b>	<b>Installation.....</b>	<b>52</b>	<b>11.</b>	<b>Troubleshooting.....</b>	<b>62</b>
6.1	Prior to installation .....	52	<b>12.</b>	<b>Repair .....</b>	<b>64</b>
6.2	Place of installation.....	52	12.1	Remedying a blockade .....	64
6.3	Prerequisites for the correct functioning of the metering devices ..	52			
6.4	Changing the metering volume internally .....	53	<b>13.</b>	<b>Shutdown and disposal .....</b>	<b>65</b>
6.4.1	SSV, SSV-E, SSVL and SSVM metering devices.....	53	13.1	Temporary shutdown .....	65
6.4.2	Metering devices with bypass bores .....	54	13.2	Final shutdown and disassembly .....	65
6.4.3	SSVD, SSVD-E and SSVDL metering devices .....	55	13.3	Disposal.....	65
6.4.4	Counting sequence of the metering screws for preassembled metering devices.....	55			
6.5	External combination of the output in case of SSVL and SSVDL .....	56			
6.6	Fixation of the metering device at the place of installation.....	57			

14.	Selection of metering devices / spare parts .....	66
14.1	SSV dividers.....	66
14.2	SSV-E metering devices .....	68
14.3	SSVD metering devices .....	69
14.4	SSVL metering devices.....	71
14.5	SSVDL metering devices.....	71
14.6	SSV-M metering devices .....	72
14.7	SSVD-E metering devices.....	72
14.8	Metering screws for SSVD, SSVD-E .....	72
14.9	Outlet cap screws.....	73
14.10	Mounting bracket SSV.....	73
14.11	Outlet fittings.....	73
14.12	Hydraulic lubrication fitting .....	73
14.13	Universal piston detector .....	74
14.14	Inlet fittings.....	74
14.15	Outlet fittings for SSVL and SSVDL .....	75
14.16	Outlet fittings for SSVL and SSVDL with check valve for connection bar.....	75
14.17	Cross-porting of outlets for SSVL and SSVDL .....	75
14.18	Cap screw G1/4 for SSVL and SSVDL.....	76
14.19	Sealing ring .....	76

## Explanation of symbols, signs and abbreviations

The following abbreviations may be used within these instructions. Symbols within safety notes mark the kind and source of the hazard.

	General warning		Dangerous electrical voltage		Risk of falling		Hot surfaces
	Unintentional intake		Crushing hazard		Pressure injection		Suspended load
	Electrostatically sensitive components		Potentially explosive atmosphere		Keep unauthorized persons away		Wear personal protective equipment (protective clothes)
	Wear personal protective equipment (goggles)		Wear personal protective equipment (face shield)		Wear personal protective equipment (gloves)		
	Wear personal protective equipment (safety shoes)		Disconnect product from mains		General obligation		
	Protective conductor (protection class I)		Protection y double or reinforced insulation (protection class II)		Protection by extra low voltage (protection class III)		Safe galvanic isolation (protection class III)
	CE marking		Disposal, recycling		Disposal of waste electrical and electronic equipment		





	Warning level	Consequence	Probability	Symbol	Meaning
	<b>DANGER</b>	Death, serious injury	imminent	●	Chronological guidelines
	<b>WARNING</b>	Death, serious injury	possible	○	Lists
	<b>CAUTION</b>	Minor injury	possible		Refers to other facts, causes, or consequences
	<b>NOTICE</b>	Property damage	possible		

Fig. 1 Abbreviations and conversion factors

re.	regarding	°C	degrees Celsius	°F	degrees Fahrenheit
approx.	approximately	K	Kelvin	Oz.	ounce
i.e.	that is	N	Newton	fl. oz.	fluid ounce
poss.	possibly	h	hour	in.	inch
if appl.	if applicable	s	second	psi	pounds per square inch
incl.	including	d	day	sq. in.	square inch
min.	minimum	Nm	Newtonmeter	cu. in.	cubic inch
max.	maximum	ml	millilitre	mph	miles per hour
min.	minute	ml/d	millilitre per day	rpm	revolutions per minute
etc.	et cetera	cm <sup>3</sup>	cubic centimetre	gal.	gallon
e.g.	for example	mm	millimetre	lb.	pound
kW	kilowatt	l	litre	hp	horse power
U	Voltage	dB (A)	sound pressure level	kp	kilopond
R	resistance	>	greater than	fpsec	feet per second
I	current	<	less than	conversion factors	
V	volt	±	plus/minus	Length	1 mm = 0.03937 in.
W	watt	∅	diameter	Area	1 cm <sup>2</sup> = 0.155 sq.in
AC	alternating current	kg	kilogram	Volume	1 ml = 0.0352 fl.oz.
DC	direct current	rh	relative humidity		1 l = 2.11416 pints (US)
A	ampere	≈	approximately	Mass	1 kg = 2.205 lbs
Ah	ampere hour	=	equal to		1 g = 0.03527 oz.
Hz	frequency [Hertz]	%	per cent	Density	1 kg/cc = 8.3454 lb./gal.(US)
nc	normally closed contact	‰	per mille		1 kg/cc = 0.03613 lb./cu.in.
no	normally open contact	≥	greater than	Force	1 N = 0.10197 kp
N/A	not applicable	≤	less than	Pressure	1 bar = 14.5 psi
ft.	feet	mm <sup>2</sup>	square millimetre	Temperature	°C = (°F - 32) x 5/9
		rpm	revolutions per minute	Output	1 kW = 1.34109 hp
		↑	Increases a value	Acceleration	1 m/s <sup>2</sup> = 3.28084 ft./s <sup>2</sup>
		↓	Reduces a value	Speed	1 m/s = 3.28084 fpsec.
					1 m/s = 2.23694 mph

# 1. Safety instructions

## 1.1 General safety instructions

- The owner must ensure that safety information has been read by any persons entrusted with works on the product or by those persons who supervise or instruct the before-mentioned group of persons. In addition, the owner must also ensure that the relevant personnel are fully familiar with and have understood the contents of the Instructions. It is prohibited to commission or operate the product prior to reading the Instructions.
- These Instructions must be kept for further use.
- The described products are manufactured according to the state of the art. Risks may, however, arise from a usage not according to the intended purpose and may result in harm to persons or damage to material assets.
- Any malfunctions which may affect safety must be remedied immediately. In addition to these Instructions, general statutory regulations for accident prevention and environmental protection must be observed.

## 1.2 General behaviour when handling the product

- The product may be used only in awareness of the potential dangers, in proper technical condition, and according to the information in these instructions.
- Familiarize yourself with the functions and operation of the product. The specified assembly and operating steps and their sequences must be observed.
- Any unclear points regarding proper condition or correct assembly / operation must be clarified. Operation is prohibited until issues have been clarified.
- Keep unauthorized persons away.
- Wear personal protective equipment always.
- Precautionary operational measures and instructions for the respective work must be observed.
- Responsibilities for different activities must be clearly defined and observed. Uncertainty seriously endangers safety.
- Safety-related protective and safety equipment must not be removed, modified or affected otherwise in its function and is to be checked at regular intervals for completeness and function.
- If protective and safety equipment has to be dismantled, it must be reassembled immediately after finishing the work, and then checked for correct function.
- Remedy occurring faults in the frame of responsibilities. Immediately inform your superior in the case of faults beyond your competence.
- Never use parts of the centralized lubrication system or of the machine as standing or climbing aids.



### 1.3 Intended use

Providing lubrication points with lubricant in progressive lubrication systems following the specifications, technical data and limits stated in these Instructions.

Usage is allowed exclusively for professional users in the frame of commercial and economic activities.

### 1.4 Foreseeable misuse

Any usage differing from the one stated in these Instructions is strictly prohibited, particularly a usage:

- outside the indicated ambient temperature range
- with non-specified means of operation
- of C3 versions (black chromate-treated surface) in areas with aggressive and corrosive materials.
- in areas with harmful radiation (e. g. ionising radiation).
- to supply, transport, or store hazardous substances and mixtures in accordance with annex I part 2-5 of the CLP regulation (EG 1272/2008) or HCS 29 CFR 1910.1200 marked with GHS01-GHS06 and GHS08 hazard pictograms.
- to feed, forward, or store gases, liquefied gases, dissolved gases, vapours, or fluids whose vapour pressure exceeds normal atmospheric pressure (1013 mbar) by more than 0.5 bar at the maximum permissible ambient temperature.
- with closure screws different from those stated in these instructions.
- With inlet and outlet fittings different from those stated in these Instructions.
- with metering screws for adjustable metering devices different from those stated in these instructions.

### 1.5 Reference on Pressure Equipment Directive 2014/68/EU

Because of its performance data the product does not achieve the limit values defined in Article 4 (1) (a) (ii) and is therefore excluded from the scope of application of Pressure Equipment Directive 2014/68/EU following Article 1 (2) (f).

### 1.6 Modifications of the product

Unauthorized conversions or modifications may result in unforeseeable impacts on safety. Therefore, any unauthorized conversions or modifications are expressly prohibited.

### 1.7 Inspections prior to delivery

The following inspections were carried out prior to delivery:

- Functional tests

### 1.8 Other applicable documents

In addition to these instructions, the following documents must be observed by the respective target group:

- The instructions of the pump that is used
- Operational instructions and approval rules
- Safety data sheet of the lubricant used

Where appropriate:

- Project planning documents
- Any documents of other components required to set up the centralized lubrication system

## 1.9 Persons authorized to operate the pump

### 1.9.1 Operator

A person who is qualified by training, knowledge and experience to carry out the functions and activities related to normal operation. This includes avoiding possible hazards that may arise during operation.

### 1.9.2 Specialist in mechanics

Person with appropriate professional education, knowledge and experience to detect and avoid the hazards that may arise during transport, installation, start-up, operation, maintenance, repair and disassembly.

### 1.9.3 Specialist in electrics

Person with appropriate professional education, knowledge and experience to detect and avoid the hazards that may arise from electricity.

## 1.10 Briefing of external technicians

Prior to commencing the activities, external technicians must be informed by the operator of the company safety provisions, the applicable accident prevention regulations to be maintained, and the functions of the superordinate machine and its protective devices.

### 1.11 Provision of personal protective equipment

The operator must provide suitable personal protective equipment for the respective location of operation and the purpose of operation.

## 1.12 Operation

The following must be observed during commissioning and operation.

- Any information within this manual and the information within the referenced documents.
- All laws and regulations that the operator must observe.

### 1.13 Emergency stopping

In case of an emergency stop the pump station by:

- Switching off the superior lubrication pump or machine, in which the product has been integrated.
- If need be by actuating the emergency stop switch of the superior machine.

#### 1.14 Transport, installation, maintenance, malfunctions, repair, shutdown, disposal

- All relevant persons must be informed of the activity prior to starting any work. Observe the precautionary operational measures and work instructions.
- Carry out transport using suitable transport and hoisting equipment on suitable ways only.
- Maintenance and repair work can be subject to restrictions at low or high temperatures (e.g. changed flow properties of the lubricant). Therefore, where possible, try to carry out maintenance and repair work at room temperature.
- Prior to performing work, the product and the machine, into which the product will be integrated, must be depressurized and secured against unauthorized activation.
- Ensure through suitable measures that movable or detached parts are immobilized during the work and that no limbs can be caught in between by inadvertent movements.
- Assemble the product only outside of the operating range of moving parts, at an adequate distance from sources of heat or cold. Other units of the machine or vehicle must not be damaged or impaired in their function by the installation.
- Dry or cover wet, slippery surfaces accordingly.
- Cover hot or cold surfaces accordingly.
- Undertake drilling at non-critical, non-load bearing parts only. Use any available boreholes. Do not damage lubrication lines and cables when drilling.
- Observe possible abrasion points. Protect the parts accordingly.

- All components used must be designed according to the maximum operating pressure and the maximum respectively minimum ambient temperature.
- No parts of the centralized lubrication system may be subjected to torsion, shear, or bending.
- Check all parts prior to their usage for contamination and clean, if necessary.
- Lubricant lines should be primed with lubricant prior to installation. This makes the subsequent ventilation of the centralized lubrication system easier.
- Observe the specified tightening torques. When tightening, use a calibrated torque wrench.
- When working with heavy parts use suitable lifting tools.
- Avoid mixing up or wrong assembly of dismantled parts. Mark these parts accordingly.

### 1.15 Initial commissioning / daily start-up

Ensure that:

- All safety devices are completely available and functional.
- All connections are correctly connected.
- All parts are correctly installed.

### 1.16 Cleaning

- Risk of fire and explosion when using inflammable cleaning agents Only use non-flammable cleaning agents suitable for the purpose.
- Do not use aggressive cleaning agents.
- Thoroughly remove residues of cleaning agents from the product.
- If possible, do not use steam jet and high pressure cleaners.
- Mark damp areas accordingly.

### 1.17 Markings and conventions

The following markings and conventions should be observed:

#### Possible markings

1-22	Outlet numbering
xxxxxxxx	Production code
↔	Outlets drilled with each other
⊗ ⊗	Outlets that must not be closed
Made in xxxx	Country of origin
SSVxxx -A	= NPTF thread
-VA	= Stainless steel 1.4305
-VAMO	= Stainless steel 1.4571
-ZnNi	= nickel-plated
without indication	= black galvanized

#### Conventions

A	= Control piston level
B	= Metering-piston level (in case of doseable metering devices)
C	= Outlet level
D	= Inlet level



Further to the findings of the workplace risk evaluation the operating company has to attach additional markings like warnings (e. g. hot surface), signs giving orders, prohibition signs or labelling as specified by GHS, where appropriate.

Fig. 2 Markings and conventions

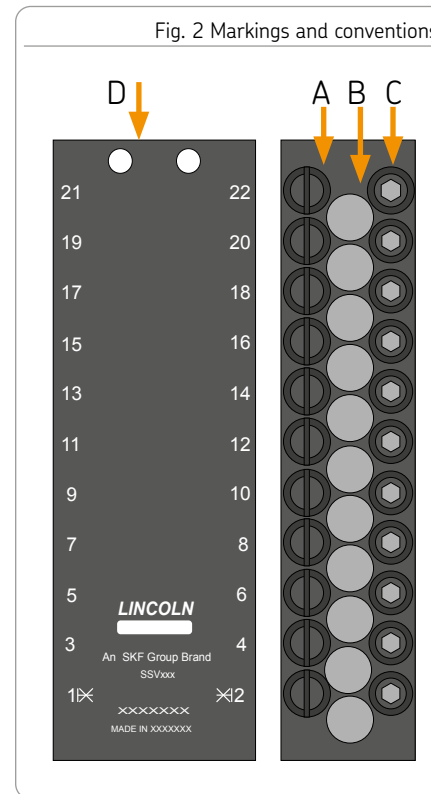

## 1.18 Residual risks

Residual risk	Possible in life cycle											Prevention/ remedy
Personal injury/ material damage due to falling of raised parts	A	B	C					G	H	K		Keep unauthorized persons away. No people may remain under suspended loads. Lift parts with adequate lifting devices.
Personal injury/ material damage due to tilting or falling of the product because of non-observance of the stated tightening torques		B	C					G		K		Observe the specified tightening torques. Fix the product only to components with sufficient load capacity. Adhere to the tightening torques stated in these instructions.
Personal injury or damage to material due to leaked lubricant		B	C	D	E	F	G			K		Be careful when connecting or disconnecting lubrication lines. Always use suitable hydraulic screw connections and lubrication lines for the stated pressures. Do not mount lubrication lines to moving parts or friction points. If this cannot be avoided, use spring coils respectively protective conduits.
Tearing or damaging of lubrication lines when installed on moving machine parts			C	D								If possible, do not install on moving parts. If this cannot be avoided, use flexible lubrication lines
Lubricant spraying out due to faulty component fitting or lubrication line connection			C	D		F	G					Use suitable hydraulic screw connections and lubrication lines for the stated pressures. Check these prior to commissioning for correct connection and damage.
Injury of persons because of loosening of the impressed balls when using metering devices with black galvanized surface (C3 version) in a strongly corrosive environment.				D	E	F	G	H				In corrosive environments there may be used metering devices in C5 version (stainless steel) only.

Life phases:

A = transport, B = installation, C = initial start-up, D = operation, E = cleaning, F = maintenance, G = fault, repair, H = shutdown, K = Disposal

## 2. Lubricants

### 2.1 General information

Lubricants are used specifically for certain application purposes. In order to fulfil their tasks, lubricants must fulfil various requirements.

The most important requirements for lubricants are:

- Reduction of abrasion and wear
- Corrosion protection
- Noise minimisation
- protection against contamination or penetration of foreign objects
- Cooling (primarily with oils)
- longevity (physical/ chemical stability)
- economic and ecological aspects



Only lubricants specified for the product (see chapter Technical data) may be used. Unsuitable lubricants may lead to a failure of the product.



Preferably do not mix lubricants. This may have unforeseeable effects on the usability and therefore on the function of the centralized lubrication system.



When handling lubricants the relevant safety data sheets and hazard designations, if any, on the packaging have to be observed.



Due to the multitude of possible additives, individual lubricants, which according to the manufacturer's data sheets fulfil the necessary specification, may not, in fact, be suitable for use in centralized lubrication systems (e. g. incompatibility between synthetic lubricants and materials). In order to avoid this, always use lubricants tested by SKF.



## 2.2 Selection of lubricants

Lubricants are an element of system design. A suitable lubricant is selected already when designing the machine and forms the basis for the planning of a centralized lubrication system.

The selection is made by the manufacturer or operator of the machine, preferably together with the lubricant supplier based on the requirement profile defined.

Should you have little or no experience with the selection of lubricants for centralized lubrication systems, please contact SKF.

If required we will be glad to support customers to select suitable components for feeding the selected lubricant and to plan and design their centralized lubrication system.

You will avoid possible downtimes due to a damage to your machine or damage to the centralized lubrication system.

## 2.3 Material compatibility

Lubricants must generally be compatible with the following materials:

- steel, grey iron, brass, copper, aluminium
- NBR, FPM, ABS, PA, PUR

## 2.4 Temperature characteristics

The lubricant used must be suitable for the specific ambient temperature of the product. The consistency/viscosity suitable for proper operation of the product must be adhered to and must not be exceeded in case of low temperatures nor fall below specification in case of high temperatures. For information see chapter Technical data.

## 2.5 Ageing of lubricants

After a prolonged downtime of the machine, the lubricant must be inspected prior to re-commissioning as to whether it is still suitable for use due to chemical or physical ageing. We recommend that you undertake this inspection already after a machine downtime of 1 week.

If doubts arise as to a further suitability of the lubricant, please replace it prior to re-commissioning and, if necessary, undertake initial lubrication by hand.

It is possible for lubricants to be tested in the company's laboratory for their suitability for being pumped in centralized lubrication systems (e.g. "bleeding").

Please contact SKF if you have further questions regarding lubricants.

## 2.6 Solid lubricants in lubrication greases

With regard to the different solid lubricants, please observe the following:

### Graphite

max. graphite content 8 %  
max. particle size 25 µm  
(possibly in in lamellar structure)

### MoS<sub>2</sub>

max. MoS<sub>2</sub> content 5 %  
max. particle size 15 µm

### Copper

Lubricants containing copper are likely to result in a layer formation on pistons, bores and mating surfaces. This may cause blockages in the centralized lubrication system.

### Calcium carbonate

Lubricants containing calcium carbonate are likely to cause a very strong wear on pistons, bores and mating surfaces.

### Calcium hydroxide

Lubricants containing calcium hydroxide are likely to harden strongly, what may result in a downtime of the centralized lubrication system

### PTFE, zinc and aluminium

Due to the findings and practical experiences gained so far, no limit values can be set for these solid lubricants yet.

## 2.6.1 Chisel pastes

### NOTICE

#### Damage to the superior machine

Chisel pastes must not be used as a lubricant for bearings.

### NOTICE

#### Damage of the centralized lubrication system

Chisel pastes may be supplied by pump element C only. Hereby the maximum operating pressure must not exceed 200 bar, as otherwise the solid lubricants contained in the chisel paste may cause increased wear.

### 3. Overview, functional description

#### 3.1 General information

The described metering devices are piston metering devices which serve to supply lubricant to lubrication points in progressive lubrication systems. Lubricant is dispensed as long as lubricant is fed to the metering device under pressure by the lubrication pump.

The pressurized lubricant moves the pistons in the metering device subsequently from their initial position into their final position, whereby the lubricant in front of the piston is displaced to the connected lubrication point/ secondary metering device.

A piston will move only when the previous piston has reached its end position. Whenever all pistons have moved from their initial position into their final position and back into their initial position again, a lubrication circuit has been completed and all connected lubrication points/secondary metering devices have been provided with lubricant.

The metering order of each piston is shown adjacently and can start or stop at any point. Depending on the specific metering device version, the lubricant quantity required for the respective lubrication point/ secondary metering device can be increased by internal or external cross-porting of outlets and can be modified by means of metering screws in case of measurable metering devices.

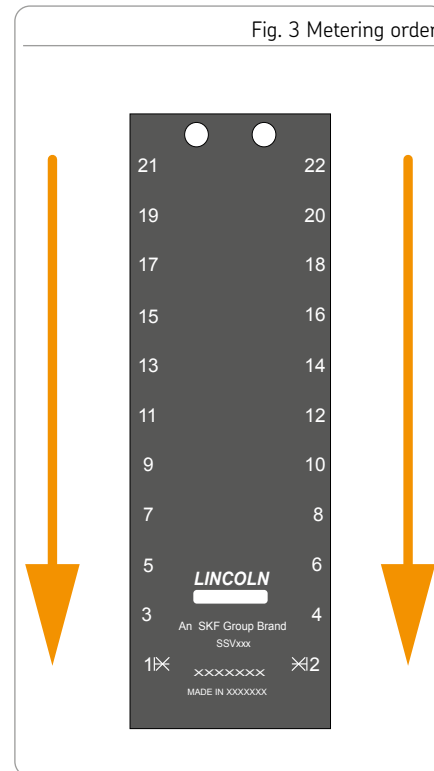

### 3.2 Fields of application

SSV metering devices can be used for almost all types of applications within a progressive lubrication system.

Typical fields of application:

- Construction machinery
- Utility road vehicles
- Agricultural machines
- Tooling machine
- Wind turbine generators
- Compactors
- Food and beverage filling systems
- Packaging machines

Fig. 4 Example of a progressive lubrication system with SSV metering devices

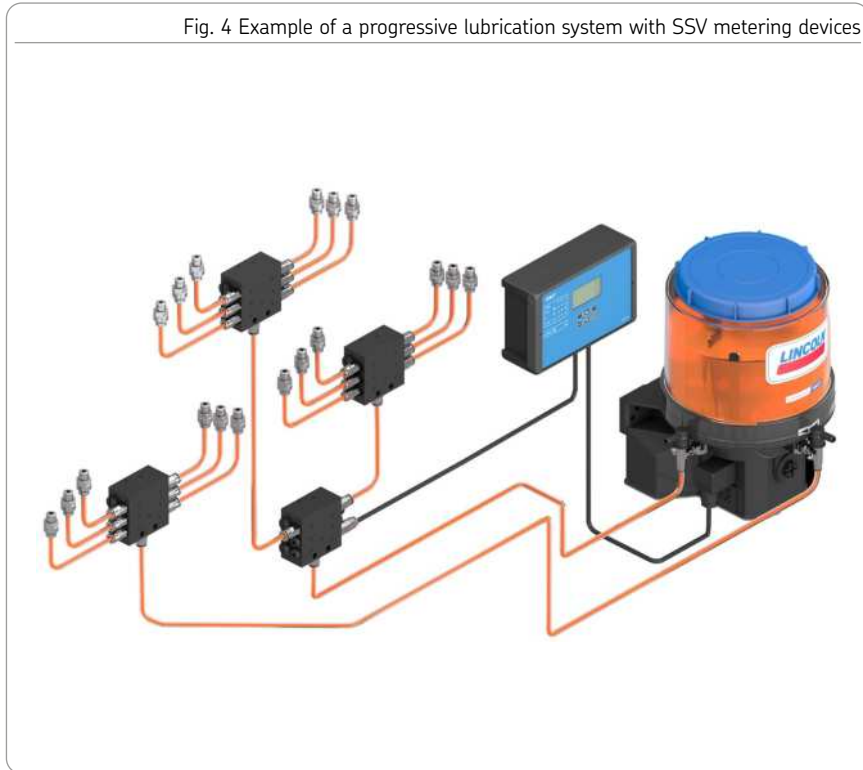

#### 3.3 Function monitoring options

The described metering devices offer the following function monitoring respectively controlling options. Which of the specified function monitoring options are possible for the respective metering device models can be found in the Technical data.

##### 3.3.1 Visual monitoring with indicator pin

The metering devices can be equipped with an indicator pin for visual monitoring of the metering piston's movement.

##### 3.3.2 Electrical monitoring/controlling via proximity switch

The proximity switch detects the movement of the indicator pin. Proximity switches are used in combination with lubrication pumps with control PCB or in combination with an external control unit to monitor and, if necessary, terminate the lubrication time.

##### 3.3.3 Electrical monitoring/controlling via piston detector

The piston detector detects the movement of the metering piston. Piston detectors are used in combination with lubrication pumps with control PCB or in combination with an external control unit to monitor and, if necessary, terminate the lubrication time.

##### 3.3.4 System-related monitoring

The individual components of a progressive lubrication system equipped with SSV metering devices are functionally connected to each other. This means, in case of a blockade in the progressive lubrication system, the pistons of the metering devices cannot move any more. As soon as a piston blocks, pressure in the progressive lubrication system will rise until lubricant will leak from the pressure control valve of the lubrication pump or in case of progressive lubrication systems with pressure control the lubrication pump will be switched off.

- K visual monitoring via indicator pin
- KN electric monitoring via indicator pin and proximity switch
- KA electric monitoring via indicator pin and proximity switch provided by the customer
- KS electric monitoring via indicator pin and limit switch
- N/ NP electric monitoring via factory-mounted proximity switch



The function monitoring of KN, KA, KS, N and NP requires an adequate processing of the signal by a lubrication pump with control PCB or by an external control unit.

<sup>6)</sup> The respective designation depends on the type of connection of the piston detector (see Technical Data of the piston detector)

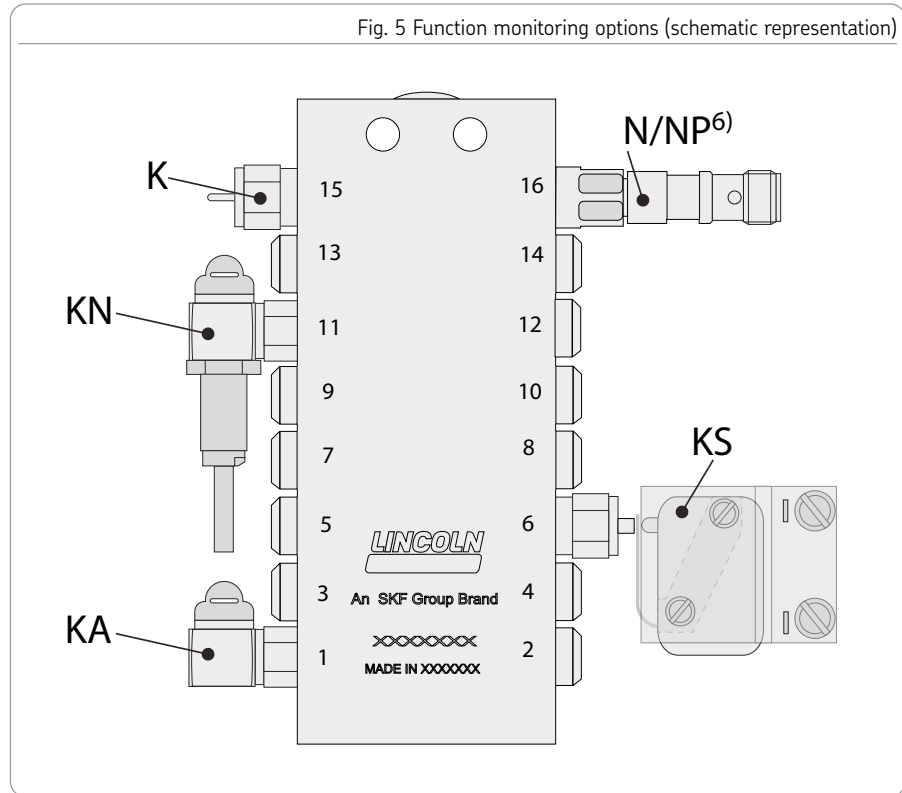

### 3.4 Course of the lubricant in the SSV metering device

The SSV 8 metering device is used as an example to show the order of the lubricant output to the individual outlets.



Only the piston movements from the right to the left end position are shown. As the lubrication pump continues to supply the pistons move in the same order again from the left to the right end position and one metering device cycle is completed.

#### Phase 1

The lubricant P1 supplied by the pump flows through the inlet E into the metering device. By doing so piston A is moved into its left end position. As a consequence the lubricant volume of P2 corresponding to the piston stroke is supplied to outlet 2.

- P1 = Lubricant supplied by the lubrication pump
- P2 = Lubricant displaced by the piston of the metering device
- P3 = Lubricant not being moved

Fig. 6 Lubricant supply sequence illustrated by means of an SSV-8 metering device phase 1

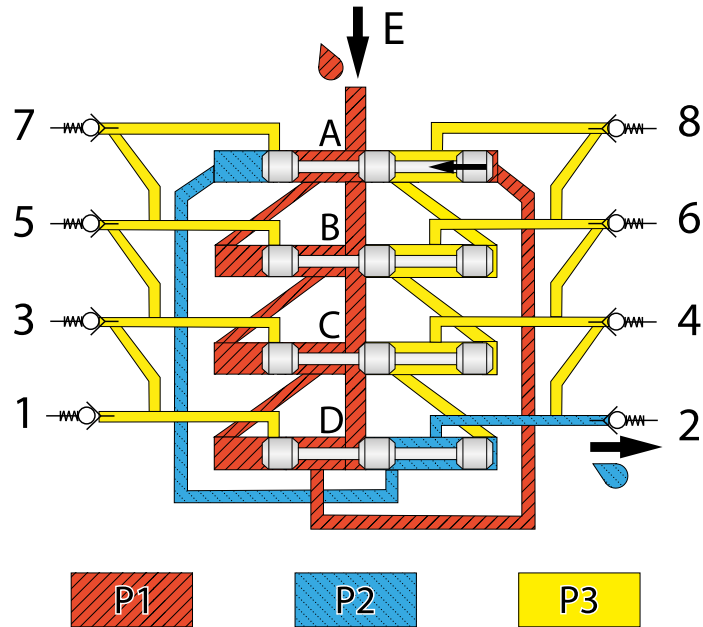

**Phase 2**

When piston A reaches its left end position, it opens the connection duct to the right end of piston B. As a consequence lubricant P1 supplied by the pump flows to the right end of piston B and piston B moves to its left end position. By doing so the lubricant volume P2 corresponding to the piston stroke is displaced to outlet 7.

Fig. 7 Course of the lubricant illustrated by means of an SSV-8 metering device Stage 2

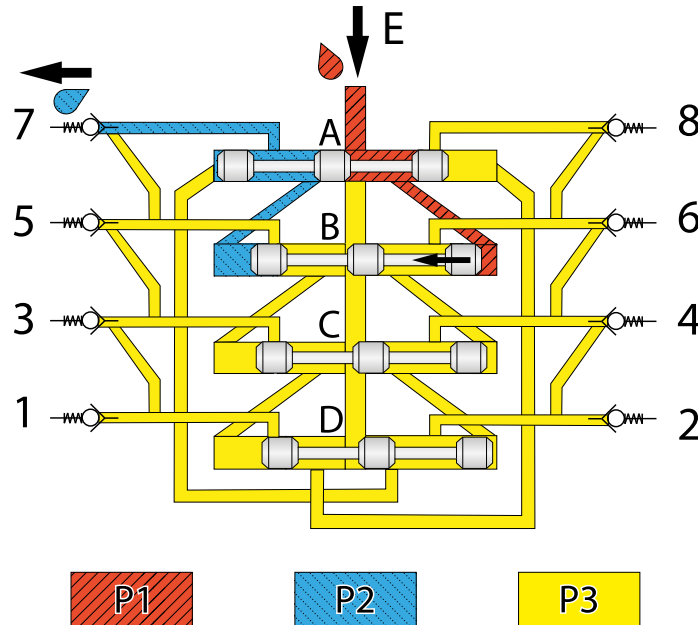



**Phase 3**

When piston B reaches its left end position, it opens the connection duct to the right end of piston C. As a consequence lubricant P1 supplied by the pump flows to the right end of piston C and piston C moves to its left end position. By doing so the corresponding lubricant volume P2 is displaced to outlet 5.

Fig. 8 Course of the lubricant illustrated by means of an SSV-8 metering device Stage 3

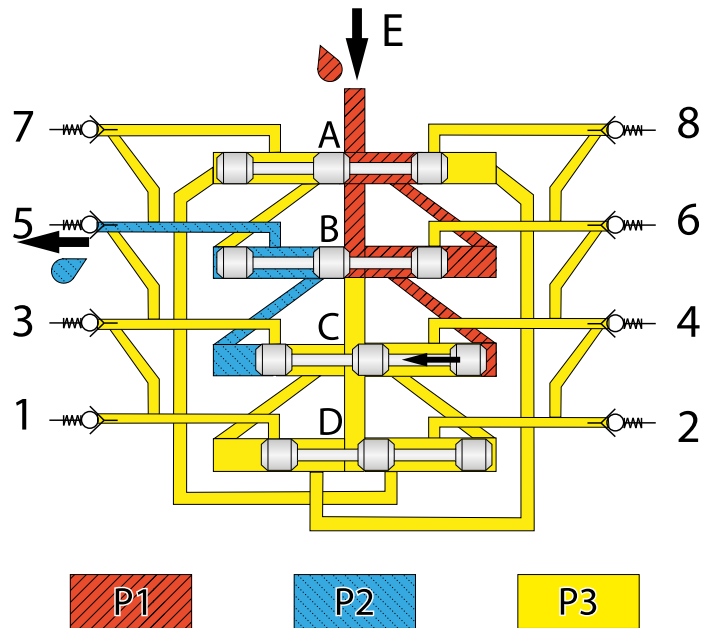

#### Phase 4

When piston C reaches its left end position, it opens the connection duct to the right end of piston D. As a consequence lubricant P1 supplied by the pump flows to the right end of piston D and piston D moves to its left end position. By doing so the corresponding lubricant volume P2 is displaced to outlet 3.

Fig. 9 Course of the lubricant illustrated by means of an SSV-8 metering device Stage 4

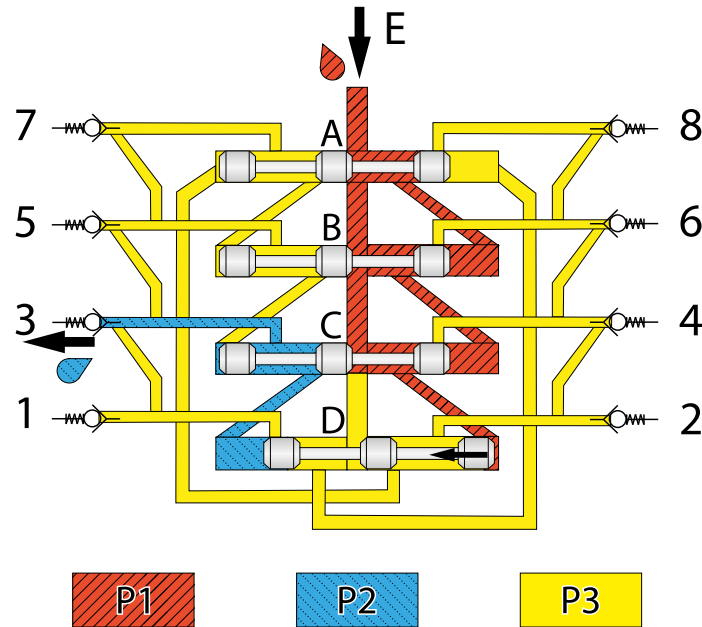

**Phase 5**

When piston D reaches its left end position, it opens the connection duct to the right end of piston A. As a consequence lubricant P1 supplied by the pump flows to the right end of piston A and piston A moves to its left end position. By doing so the corresponding lubricant volume P2 is displaced to outlet 1.

**Phases 6 - 8**

In Phases 6 to 8 the lubricant movement follows the same principle as in phases 1 to 5 and lubricant is supplied from the outlets 8, 6 and 7 (phases 6, 7 and 8). If the supply continues after phase 8, the cycle starts from the beginning again.

Fig. 10 Course of the lubricant in the metering device phase 5

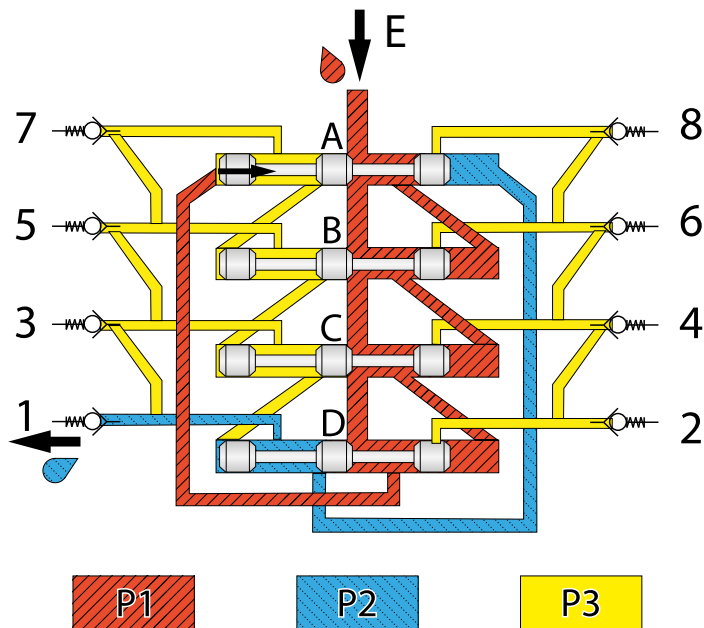

### 3.5 Course of the lubricant in the SSVD metering device

The SSVD 6 metering device is used as an example to show the piston movements and the lubricant supply to the individual outlets.

#### Phase 1

The lubricant P1 supplied by the pump flows through the inlet E into the metering device. By doing so metering piston B1 is moved into its left end position. As a consequence the corresponding lubricant volume P2 is supplied to outlet 6.

P1 = Lubricant supplied by the lubrication pump

P2 = Lubricant displaced by the piston of the metering device

P3 = Lubricant not being moved

Fig. 11 Course of the lubricant illustrated by means of an SSVD-6 metering device phase 1

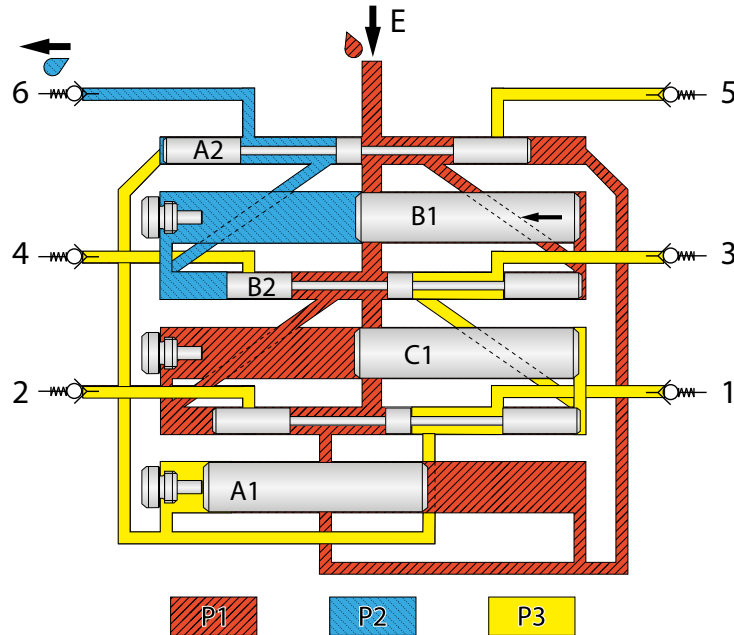

**Phase 2**

As soon as metering piston B1 reaches its left end position, the pressurized lubricant P2 moves the control piston B2 leftward and additionally displaces the lubricant in front of control piston B2 to outlet 6.

The total output of outlet 6 corresponds to the output of metering piston B1 and control piston B2.

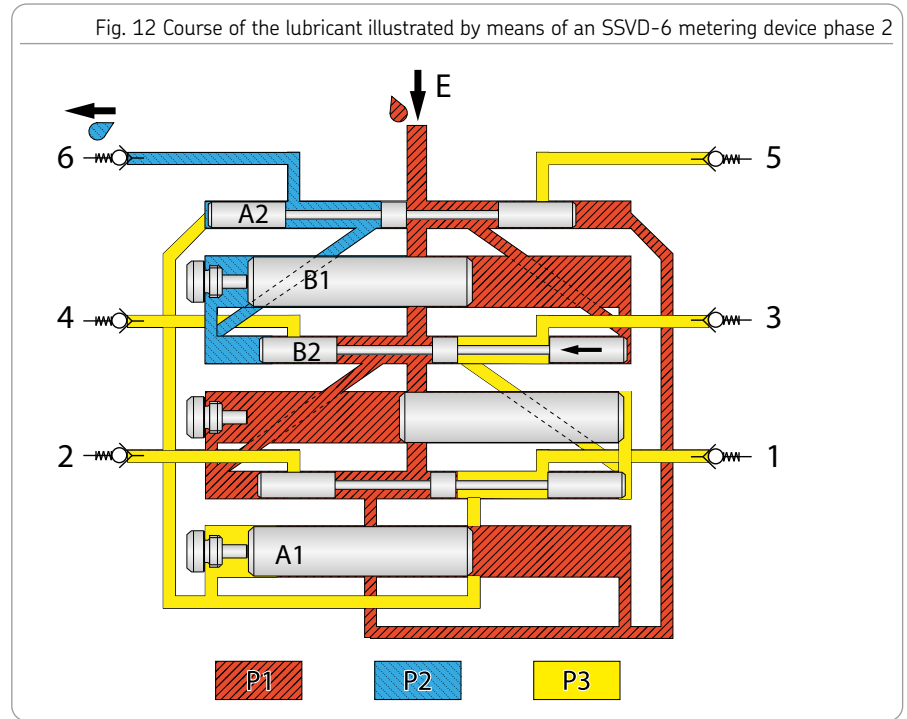

### Phase 3

The control piston B2 has reached its left end position. Thereby it opens the connection duct to the right end of control piston C2 and metering piston C1. The pressurized lubricant P1 is now located at the right end of control piston C2 and metering piston C1 and first moves metering piston C1 to the left due to its larger cross-section and then displaces the lubricant enclosed on the left side of metering piston C1 to outlet 4.

### Phase 4

As soon as metering piston C1 reaches its left end position, the pressurized lubricant P2 moves the control piston C2 leftward and additionally displaces the lubricant in front of control piston C2 to outlet 4.

The total output of outlet 4 corresponds to the output of metering piston C1 and control piston C2.

Fig. 13 Course of the lubricant illustrated by means of an SSVD-6 metering device phases 3 and 4

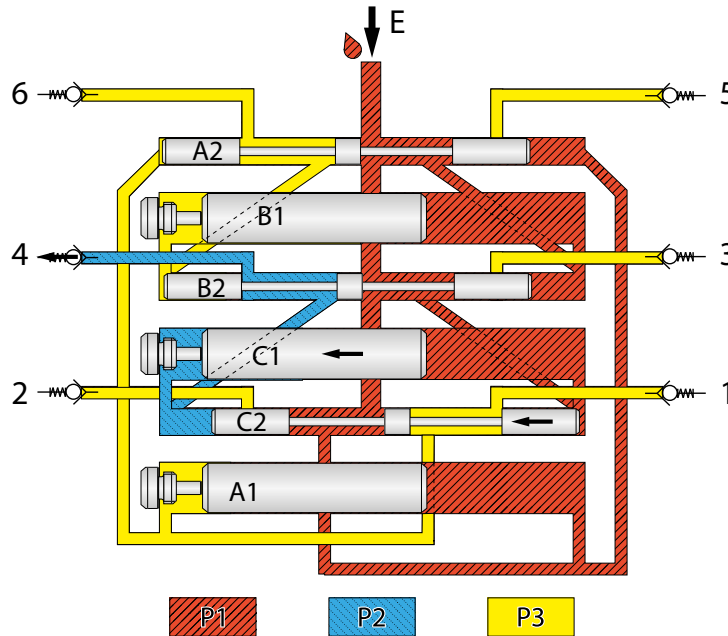

**Phase 5**

The control piston C2 has reached its left end position. Thereby it opens the connection duct to the left end of control piston A2 and metering piston A1. The pressurized lubricant P1 is now located at the left end of control piston A2 and metering piston A1. Due to its larger cross-section lubricant P1 first moves metering piston A1 to the right and then displaces the lubricant enclosed on the right side of metering piston A1 to outlet 2.

**Phase 6**

As soon as metering piston A1 reaches its right end position, the pressurized lubricant P1 moves the control piston A2 (black arrow) rightward and additionally displaces the enclosed lubricant in front of control piston C2 to outlet 2.

The total output of outlet 2 corresponds to the output of metering piston A1 and control piston A2.

Fig. 14 Course of the lubricant illustrated by means of an SSVD-6 metering device phases 5 and 6

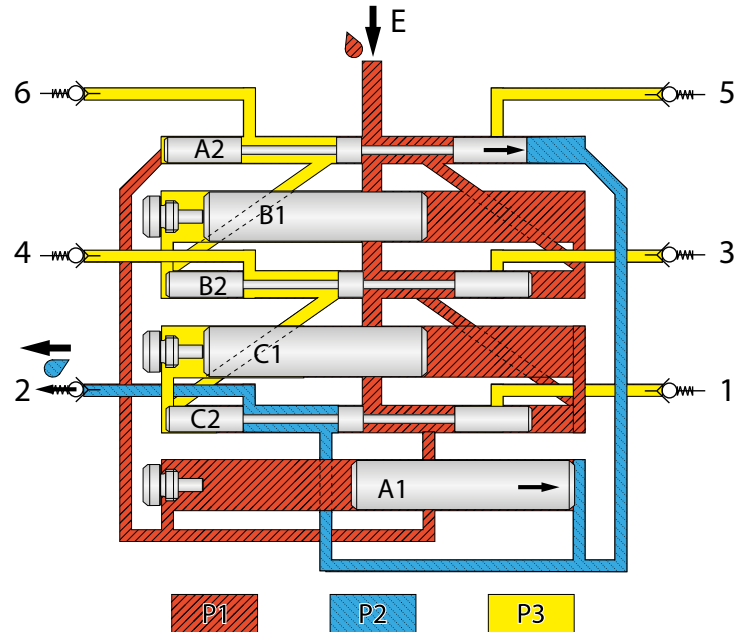

### Phase 7

Control piston A2 has reached its right end position. Thereby it opens the connection duct to the left end of control piston B2 and metering piston B1. The pressurized lubricant P1 is now located at the left end of control piston B2 and metering piston B1. Due to its larger cross-section lubricant P1 first moves metering piston B1 to the right and then displaces the lubricant enclosed on the right side of metering piston B1 to outlet 5.

### Phase 8

As soon as metering piston B1 reaches its right end position, the pressurized lubricant P1 moves the control piston A2 (black arrow) rightward and additionally displaces the enclosed lubricant in front of control piston C2 to outlet 5.

The total output of outlet 5 corresponds to the output of metering piston B1 and control piston B2.

Fig. 15 Course of the lubricant illustrated by means of an SSVD-6 metering device phases 7 and 8

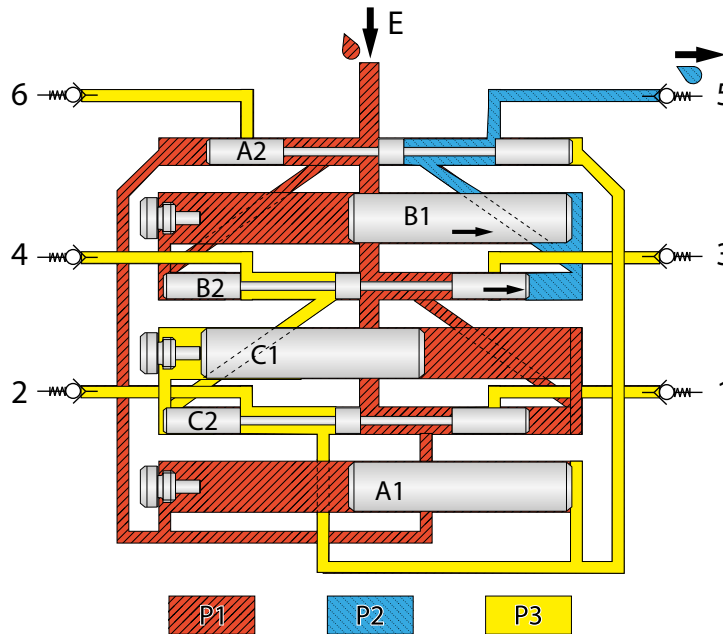



**Phase 9**

The control piston B2 has reached its right end position. Thereby it opens the connection duct to the left end of control piston C2 and metering piston C1. The pressurized lubricant P1 is now located at the left end of control piston C2 and metering piston C1. Due to its larger cross-section lubricant P1 first moves metering piston C1 to the right and then displaces the lubricant enclosed on the right side of metering piston C1 to outlet 3.

**Phase 10**

As soon as metering piston C1 reaches its right end position, the pressurized lubricant P1 moves the control piston C2 (black arrow) rightward and additionally displaces the enclosed lubricant in front of control piston C2 to outlet 3.

The total output of outlet 3 corresponds to the output of metering piston C1 and control piston C2.

Fig. 16 Course of the lubricant illustrated by means of an SSVD-6 metering device phases 9 and 10

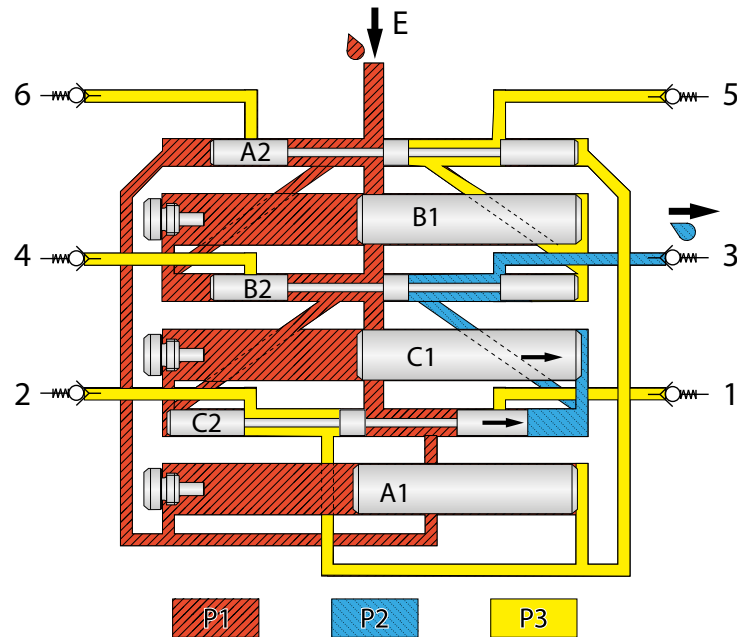

**Phase 11**

The control piston C2 has reached its right end position. Thereby it opens the connection duct to the right end of control piston A2 and metering piston A1. The pressurized lubricant P1 is now located at the left end of control piston A2 and metering piston A1. Due to its larger cross-section lubricant P1 first moves metering piston A1 to the left and then displaces the lubricant enclosed on the left side of metering piston A1 to outlet 1.

**Phase 12**

As soon as metering piston A1 reaches its left end position, the pressurized lubricant P1 moves the control piston A2 leftward and additionally displaces the enclosed lubricant on the left side of control piston A2 to outlet 1.

The total output of outlet 1 corresponds to the output of metering piston A1 and control piston A2.

Now a full cycle of the metering device has been completed.

Fig. 17 Course of the lubricant illustrated by means of an SSSD-6 metering device phases 11 and 12

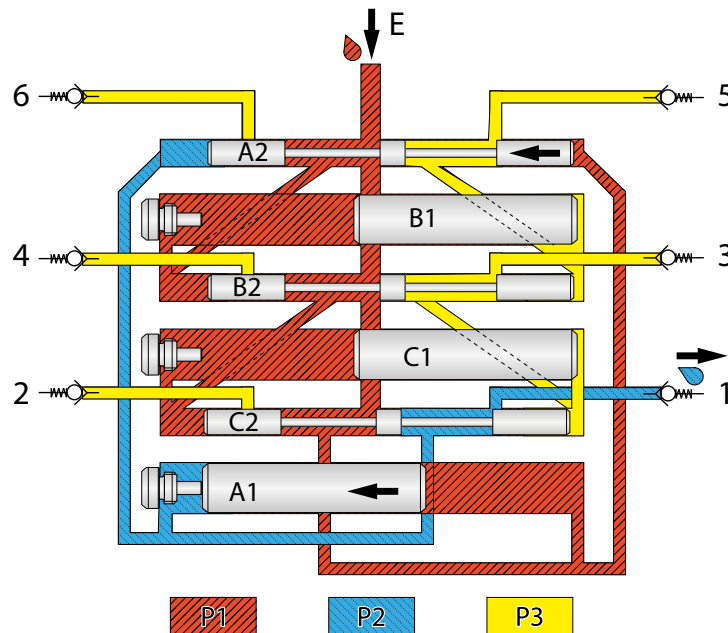

## 4. Technical data

### 4.1 Technical data SSV/SSV-E/SSVM

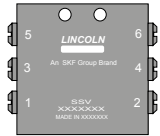
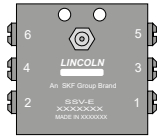
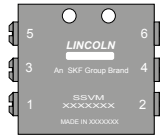
		SSV	SSV-E	SSVM
				
Maximum operating pressure	bar	350	350	200
Minimum operating pressure	bar	20	20	20
<sup>5)</sup> Max. differential pressure between 2 outlets	bar	100	100	40
Number of outlets		6-22	6-22	6-12
Installation position		any	any <sup>1)</sup>	any
Inlet thread		G1/8	G1/8	G1/8
Outlet thread		M10 x 1	M10 x 1	M8 x 1
Connectable lubrication lines	mm	Ø 4   Ø 6	Ø 4   Ø 6	Ø 4
<sup>2)</sup> Metering volume per stroke and outlet	cm <sup>3</sup>	0.2	0.2	0.07
Possible material versions		Steel, black galvanized Stainless steel 1.4305 (V2A) Stainless steel 1.4571 (V4A)	Steel, black galvanized Stainless steel 1.4305 (V2A)	Steel, black galvanized
<sup>3)</sup> Function monitoring options		K   KA   KN   N   NP   KS		K   KA   KN   KS
Suitable lubrication grease consistencies		Lubrication greases up to and including NLGI 2		
Suitable lubrication oil viscosities		Lubrication oils of at least 40 mm <sup>2</sup> /s at ambient temperature		
<sup>4)</sup> Ambient temperature range without electrical component	°C	-40 to + 200*	-40 to + 200*	-25 to + 70
Ambient temperature range with electrical component		see Technical data of the respective electrical component		

<sup>1)</sup> Installation position limited by the emergency lubrication fitting.

<sup>2)</sup> When using function monitoring devices K, KA, KN, the metering volume on those outlets provided with lubricant by a piston via indicator pin is reduced as follows: SSV, SSV-E by about 35%, SSVM by about 25%.

<sup>3)</sup> Also see chapter Function monitoring options

<sup>4)</sup> The stated ambient temperature range assumes the transportability of the lubricant applied and the use of fittings and lubrication lines suitable for the respective existing ambient temperature.

\* with mechanical component K the ambient temperature range is -40 °C to +120 °C

<sup>5)</sup> The maximum differential pressure must not be exceeded and can be reduced by selecting the right length and diameter of the line.

## 4.1.1 Construction sizes, dimensions and weights SSV/SSV-E/SSVM

SSV/SSV-E Outlets	A Height (mm)	B Width (mm)	C Depth (mm)	Weight (kg)
6	60	60	30/45*	0.8
8	75	60	30/45*	1.0
10	90	60	30/45*	1.2
12	105	60	30/45*	1.4
14	120	60	30/45*	1.6
16	135	60	30/45*	1.8
18	150	60	30/45*	2.0
20	165	60	30/45*	2.2
22	180	60	30/45*	2.4

SSVM Outlets	A Height (mm)	B Width (mm)	C Depth (mm)	Weight (kg)
6	48.5	50	25	0.4
8	60	50	25	0.5
10	71.5	50	25	0.6
12	83	50	25	0.7
14	210	60	40	3.7

\* SSV-E: Depth including emergency lubrication fitting

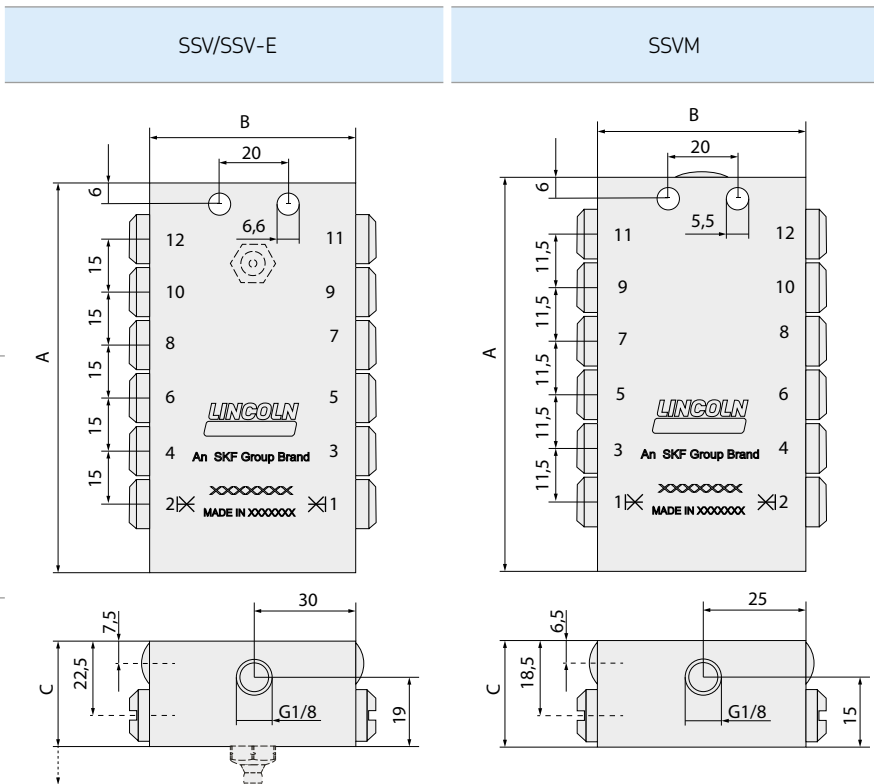

## 4.1.2 Tightening torques SSV/SSV-E

Piston level		Nm
K	1	18-2
KA	1 + 2	10 ± 1.0
KN	1 + 2 + 3	7 ± 1.0
N	Adapter to metering device	15 ± 1
NP	Piston detector to adapter	7 ± 0.5
P		18-2
Outlet level		Nm
A/B/C/D/E		11 ± 0.5
C1		10 ± 0.5
F	Closure screw	15 ± 1.5
Inlet level		Nm
G/L		10 ± 1.0
H		17 ± 1.7
M		15 ± 1.5
H1/M1	for plastic tube	10 ± 1.0
H1/M1	for steel tube	11 ± 1.0
Emergency lubrication fitting (SSV-E)		
R		14 ± 0.7
Fastening screws		
T	M 6 x .... (8.8) dry	10 ± 1.0
	M 6 x .... (8.8) oiled	7.5 ± 0.8

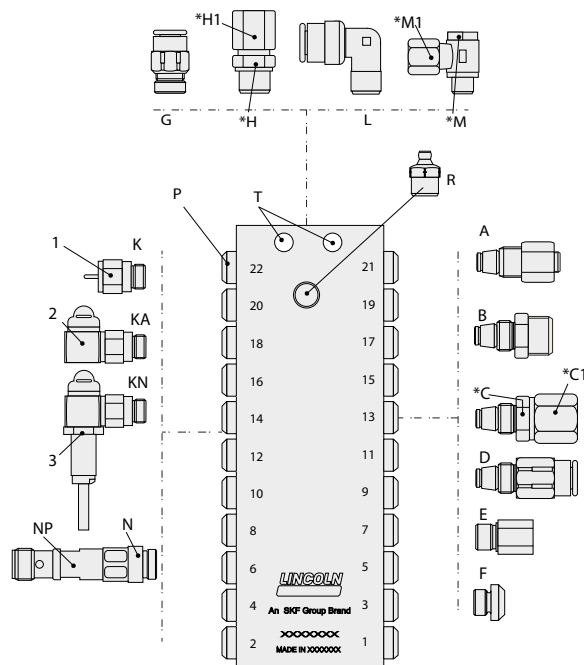

Secure all lubrication fittings and all screw fittings without sealing edges with a medium-strength screw lock (e.g. Loctite 274).

\*In case of an oiled assembly reduce the stated tightening torques by 20%.

### 4.1.3 Tightening torques SSVM

Piston level			Nm
K		1	10 ± 1.0
KA		1+2	2 ± 0.2
KN		1+2+3	2 ± 0.2
Outlet level			Nm
A/C/E			10 ± 1.0
B			8 ± 0.8
A1/E1	for plastic tube		5 ± 0.5
A2/E2	for steel tube		10 ± 1.0
D			6 / 0.5
Inlet level			Nm
F/H			10 ± 1.0
G			17 ± 1.7
G1/L1	for plastic tube		10 ± 1.0
G2/L2	for steel tube		11 ± 1.0
L			15 ± 1.5
M	Lubrication fitting		14 ± 0.7
Fastening screws			Nm
N	M 5 x .... (8.8)	dry	6 ± 0.6
	M 5 x .... (8.8)	oiled	4.5 ± 0.4

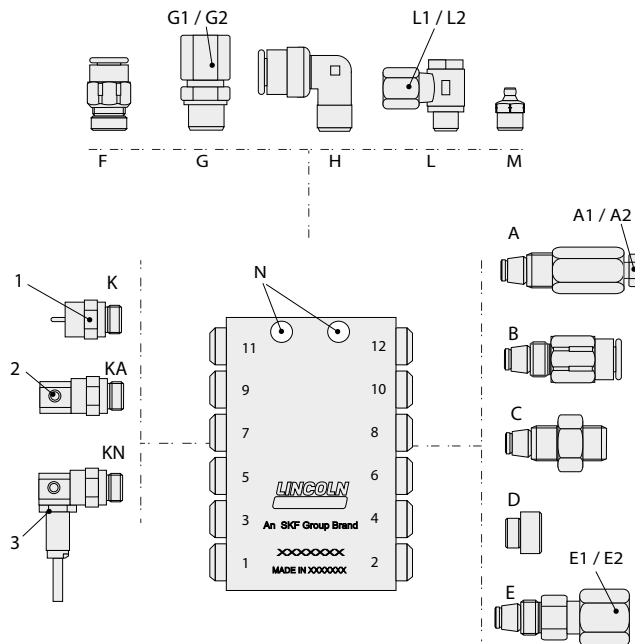

Secure all lubrication fittings and all screw fittings without sealing edges with a medium-strength screw lock (e.g. Loctite 274).

\*In case of an oiled assembly reduce the stated tightening torques by 20%.

## 4.2 Technical data SSVD/SSVD-E

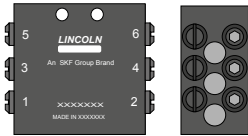
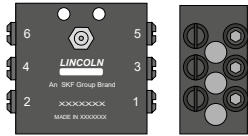
		SSVD	SSVD-E
			
Maximum operating pressure	bar	350	350
Minimum operating pressure	bar	20	20
2) Max. differential pressure between 2 outlets	bar	100	100
Number of outlets		6-22	6-22
Installation position		any	any <sup>1)</sup>
Inlet thread		G1/8	G1/8
Outlet thread		M10 x 1	M10 x 1
Connectable lubrication lines	mm	Ø 4   Ø 6	Ø 4   Ø 6
2) Metering volume per stroke and outlet		The metering volume is adjusted via metering screws and amounts to a maximum of 1.8 cm <sup>3</sup> per stroke	
Possible material versions		Steel, black galvanized	Steel, black galvanized
3) Function monitoring		K   KA   KN   N   NP   KS	
Suitable lubrication grease consistencies		Lubrication greases up to and including NLGI 2	
Suitable lubrication oil viscosities		Lubrication oils of at least 40 mm <sup>2</sup> /s at ambient temperature	
4) Ambient temperature range without electrical component	°C	-25 to +70	-25 to +70
4) Ambient temperature range with electrical component		see Technical data of the respective electrical component	

1) Installation position limited by the emergency lubrication fitting.

2) When using indicator pins, the output volume of the outlets equipped with indicator pins is reduced by about 10%.

3) Also see chapter Function monitoring options

4) The stated ambient temperature range assumes the transportability of the lubricant applied and the use of fittings and lubrication lines suitable for the respective existing ambient temperature.

5) The maximum differential pressure must not be exceeded and can be reduced by selecting the right length and diameter of the line.

#### 4.2.1 Construction sizes, dimensions and weights SSVD/SSVD-E

SSVD/ SSVD-E Outlets	A Height (mm)	B Width (mm)	C Depth (mm)	Weight (kg)
6	70	60	40/55*	1.2
8	85	60	40/55*	1.4
10	100	60	40/55*	1.7
12	115	60	40/55*	2.0
14	130	60	40/55*	2.2
16	145	60	40/55*	2.4
18	160	60	40/55*	3.7
20	175	60	40/55*	3.9
22	190	60	40/55*	3.2

\* SSVD-E: Depth including emergency lubrication fitting

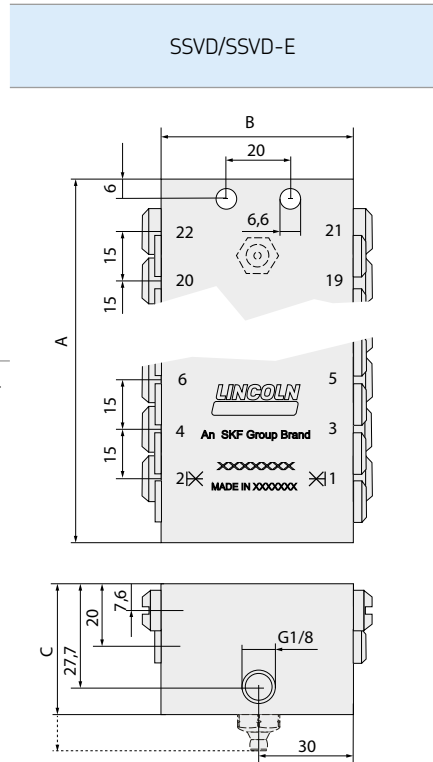



## 4.2.2 Tightening torques SSV-D/SSVD-E

Piston level		Nm
K	1	18-2
KA	1 + 2	10 ± 1.0
KN	1 + 2 + 3	7 ± 1.0
N	Adapter to metering device	15 ± 1
NP	Piston detector to adapter	7 ± 0.5
P		18-2
Outlet level		Nm
A/B/C/D/E		11 ± 0.5
C1		10 ± 0.5
F	Closure screw	15 ± 1.5
Inlet level		Nm
G/L		10 ± 1.0
H		17 ± 1.7
M		15 ± 1.5
H1/M1	for plastic tube	10 ± 1.0
H1/M1	for steel tube	11 ± 1.0
Emergency lubrication fitting (SSV-E)		
R		14 ± 0.7
Metering screws (SSVD)		
S		15 ± 1.0
Fastening screws		
T	M 6 x .... (8.8) dry	10 ± 1.0
	M 6 x .... (8.8) oiled	7.5 ± 0.8

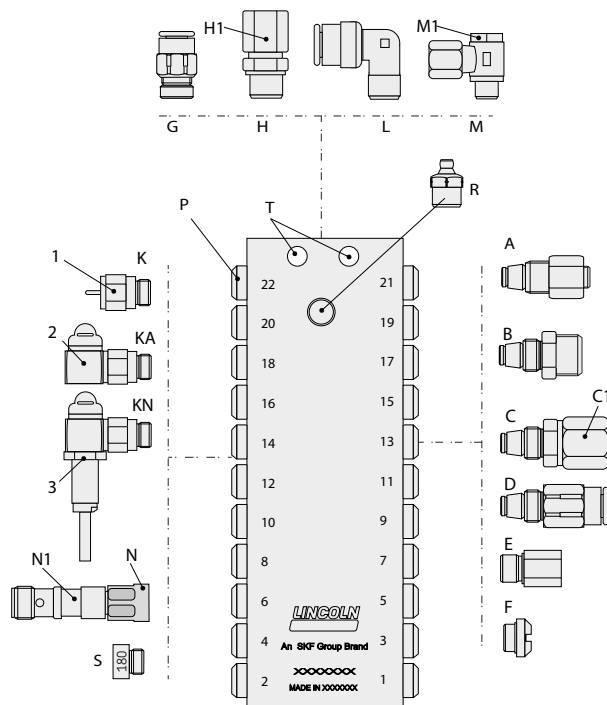

Secure all lubrication fittings and all screw fittings without sealing edges with a medium-strength screw lock (e.g. Loctite 274).

\*In case of an oiled assembly reduce the stated tightening torques by 20%.

## 4.3 Technical data of the SSVL/SSVDL

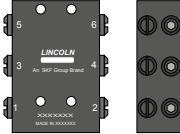
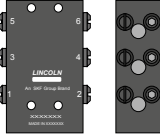
		SSVL	SSVDL
			
Maximum operating pressure	bar	350	350
Minimum operating pressure	bar	20	20
<sup>5)</sup> Max. differential pressure between 2 outlets	bar	100	100
Number of outlets		6-14	6-14
Installation position		any	any <sup>1)</sup>
Inlet thread		G1/4	G1/4
Outlet thread		R1/4"	R1/4"
Connectable lubrication lines	mm	Ø8   Ø10   Ø12	Ø8   Ø10   Ø12
<sup>2)</sup> Metering volume per stroke and outlet		0.2 cm <sup>3</sup>	The metering volume is adjusted via metering screws and amounts to a maximum of 1.8 cm <sup>3</sup> per stroke
Possible material versions		Steel, black galvanized	Steel, black galvanized
<sup>3)</sup> Function monitoring		K   KA   KN   N   NP	
Suitable lubrication grease consistencies		Lubrication greases up to and including NLGI 2	
Suitable lubrication oil viscosities		Lubrication oils of at least 40 mm <sup>2</sup> /s at ambient temperature	
<sup>4)</sup> Ambient temperature range without electrical component	°C	-25 to +70	-25 to +70
<sup>4)</sup> Ambient temperature range with electrical component		see Technical data of the respective electrical component	

<sup>1)</sup> Installation position limited by the emergency lubrication fitting.

<sup>2)</sup> When using indicator pins, the output volume of the outlets equipped with indicator pins is reduced by about 10%.

<sup>3)</sup> Also see chapter Function monitoring

<sup>4)</sup> The stated ambient temperature range assumes the transportability of the lubricant applied and the use of fittings and lubrication lines suitable for the respective existing ambient temperature.

<sup>5)</sup> The maximum differential pressure must not be exceeded and can be reduced by selecting the right length and diameter of the line.

4.3.1 SSVL/SSVDL

SSVL Outlets	A Height (mm)	B Width (mm)	C Depth (mm)	Weight (kg)
6	90	60	40	1.5
8	120	60	40	2.1
10	150	60	40	2.6
12	180	60	40	3.3
14	210	60	40	3.9

SSVDL Outlets	A Height (mm)	B Width (mm)	C Depth (mm)	Weight (kg)
6	110	60	50	2.6
8	140	60	50	3.3
10	170	60	50	4.0
12	200	60	50	4.7
14	230	60	50	5.4

When using a metering device with monitoring additional free space may be required.

SSVL

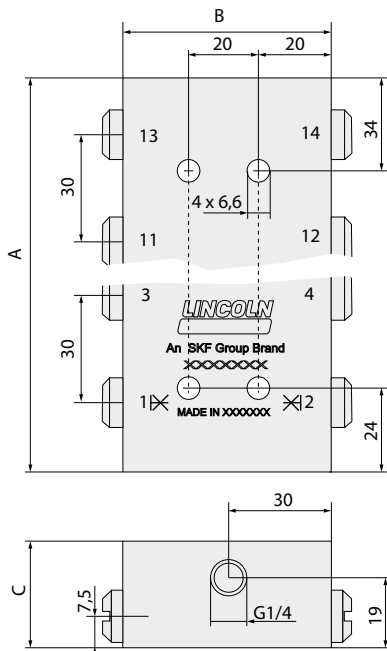

SSVDL

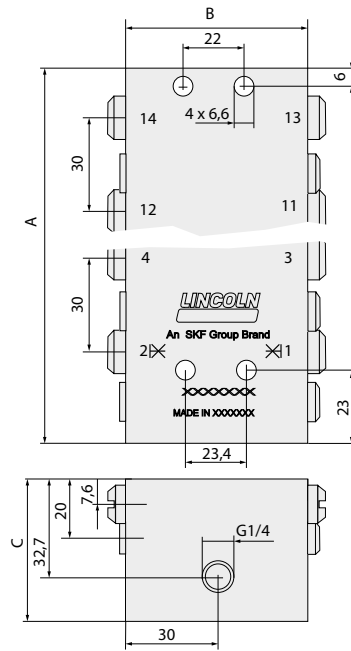

#### 4.4 Tightening torques SSVL, SSSDL

Piston level		Nm
K	1	18-2
KA	1 +2	10 ± 1.0
KN	1 +2 +3	7 ± 1.0
N	Adapter to metering device	15 ± 1
NP	Piston detector to adapter	7 ± 0.5
P		18-2
Outlet level		Nm
A/B		35 + 5
B1/C1	for steel tube Ø 8 x 1 mm	25 + 2.5
C3	for steel tube Ø 8 x 2 mm	30 + 3.0
B2/C2	for steel tube Ø 10 x 1 mm	35 + 3.0
C4	for steel tube Ø 10 x 2 mm	40 + 4.0
B3	for steel tube Ø 12 x 1 mm	45 + 4.0
	for steel tube Ø 12 x 1.5 mm	55 + 5.0
C/D		30 ± 3.0
Inlet level		Nm
E/F		30 ± 3.0
G		40 ± 4.0
E1/G1	for steel tube Ø 8 x 1 mm	25 + 2.5
E2/G2	for steel tube Ø 8 x 2 mm	30 + 3.0
E3/G3	for steel tube Ø 10 x 1 mm	35 + 3.0
E4/G4	for steel tube Ø 10 x 2 mm	40 + 4.0
H		15 + 2.0
Metering screws (SSVDL only)		Nm
S		15 ± 1.5
Fastening screws		Nm
T	M 6 x .... (8.8) dry	10 ± 1.0
	M 6 x .... (8.8) oiled	7.5 ± 0.8

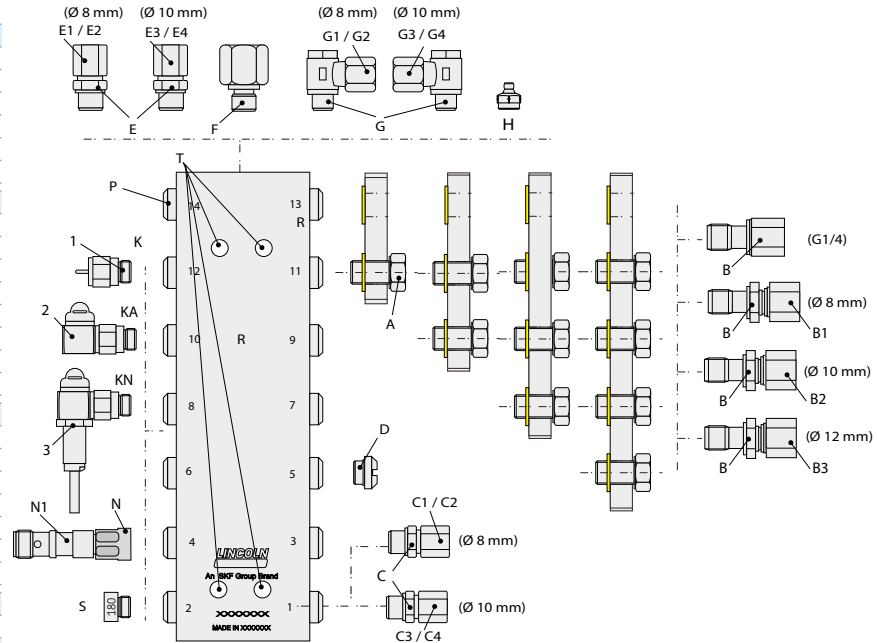

Secure all lubrication fittings and all screw fittings without sealing edges with a medium-strength screw lock (e.g. Loctite 274).  
 \*In case of an oiled assembly reduce the stated tightening torques by 20%.

## 4.5 Technical data of the universal piston detector

Part number	234-13163-9	
Ambient temperature	[°C]	-40 ....+85
Housing	Sensor face: 1.4404, housing = 1.4016, plug = PEI	
Type of installation	Flush mounted in the adapter	
Switching status display	LED	yellow (lit during damping)
Electrical connection	M12x1 connector, gold-plated contacts	
Rated switching distance	[mm]	2.6 Delivered condition
Secured switching distance (Sr)	[mm]	2.2 ±10%
Switch point/reproducibility	[% of Sr]	±10 %
Admissible operating pressure	[bar]	like the one of the metering device
Operating voltage	[V]	10-36 DC, supply class 2 according to cULus
Current consumption	[mA]	< 5
Reverse polarity protection	YES	
Output function	Normally open contact (NO)	
Voltage drop	[V]	3.5
Minimum load current	[mA]	5
Residual current	[mA]	< 0.8
Current rating	[mA]	100
Short-circuit proof   Overload proof	YES   YES	
Switching frequency	[Hz]	10, for damping area of Ø 4 mm up to 7 Hz
Tightening torques	[Nm]	See indications on tightening torques of the metering devices
Degree of protection	[IP]	65/68/69K with properly screwed cable socket

## Dimensional drawing

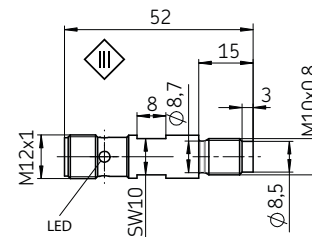

## 2-wire DC PNP/NPN

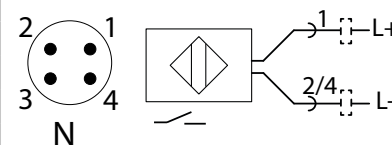

## 3-wire DC PNP

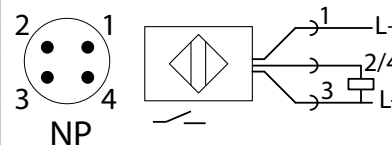

## 4.6 Technical data proximity switch DC version

Part number	234-10812-8	
Ambient temperature	[°C]	-25 ....+70
Materials	Housing = Nickel-plated brass, active area = PBT	
Type of installation	flush	
Type of connection   Cable diameter	[mm]	2000 mm PVC cable   3.2 mm
Cable version  Core cross-section	[mm <sup>2</sup> ]	PBT   3 x 0.14
Switching status display	LED	yellow (lit during damping)
Rated switching distance	[mm]	2
Secured switching distance	[mm]	0-1.62
Reduction factor $r_{Al}$   $r_{Cu}$   $R_{V2A}$	[mm]	0.3   0.2   0.7
Hysteresis	[% of Sr]	typ. 10 %
Operating voltage $U_B$	[V]	10-30 DC
Operating current	[mA]	0-200
Reverse polarity protection	YES	
Output function	Normally open contact PNP	
Voltage drop	[V]	≤ 3
No-load current	[mA]	≤ 15
Residual current	[mA]	0 - 0.5 mA typ. 0.1 μA at 25 °C
Short-circuit protection	Clocking	
Switching frequency	[Hz]	0-800
Degree of protection	[IP]	67

## Dimensional drawing

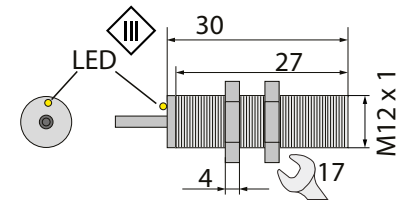

## Electrical connection

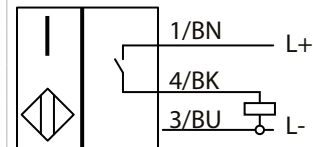

## 4.7 Technical data proximity switch AC/DC version

Part number	234-13180-3	
Ambient temperature	[°C]	-25 ....+80
Materials		Materials = nickel-plated brass
Type of installation		flush
Type of connection	[mm]	2000 mm PUR cable
Core cross-section	[mm <sup>2</sup> ]	2 x 0.25
Switching status display	LED	yellow (lit during damping)
Rated switching distance	[mm]	2
Reproducibility	[mm]	0.04
Response time/Settling time	[ms]	0.4
Readiness delay	[ms]	100
Operating voltage $U_B$	[V]	20 - 320 DC
including residual ripple	[V]	20 - 265 AC
Protected against reverse polarity   Short-circuit proof		YES   NO
Output function		Normally open contact (NO)
Current consumption	[mA]	1.5 (AC)   1.0 (DC)
Current rating	[mA]	200
Switching frequency	[Hz]	25 (AC)   1200 (DC)
Degree of protection	[IP]	67

## Dimensional drawing

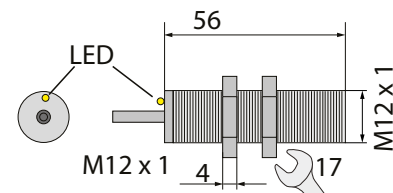

## Electrical connection

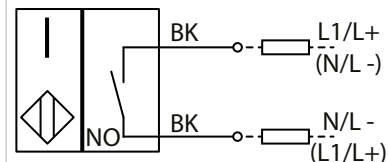

## 4.8 Technical data proximity switch DC version for SSVM

Part number	234-10757-4	
Ambient temperature	[°C]	-25 ....+70
Materials	Housing = Stainless steel, active area = POM	
Type of installation	flush	
Switching status display	LED	yellow (lit during damping)
Electrical connection	Plug-in connector, 3-wire	
Rated voltage	[V]	24 DC
Rated operating current	[mA]	100
Readiness delay	[ms]	25
Hysteresis	15 % maximum	
Repeatability	5 %	
Operating voltage	[V]	6-30 DC
Damped no-load current	[mA]	10
Secured switching distance	[mm]	0 / 0.65
Output function	Normally-open contact (NO)/PNP	
Voltage drop	[V]	3
Nominal switching distance	[mm]	0.8
Residual current	[µA]	max. 80
Residual ripple	[%]	10
Protected against reverse polarity   Short-circuit proof	YES   YES	
Switching frequency	[Hz]	3000
Degree of protection	[IP]	67

## Dimensional drawing

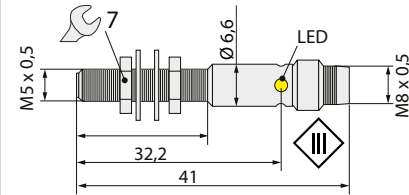

## Electrical connection

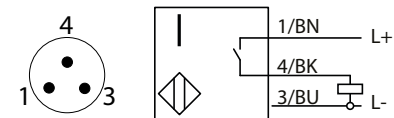



## 4.9 Technical data limit switch

Part number	236-13281-2	
Ambient temperature	[°C]	-40 ....+85
Materials	Nylon, fibre glass reinforced	
Type of actuator	Stainless steel plunger sealed with elastomer bellows	
Rated contact current	[V]	5A at 250 AC
Contact arrangement	NO contact / NC contact type SP	
Contact material	Silver	
Degree of protection	[IP]	67
Switch actuating force	[N]	3.9
Switch detaching force	[N]	1.1
Mechanical durability	10 <sup>6</sup> actuations	
Connection cable	firmly wired in the housing, 3-core silicone/rubber 2000 mm long	
Protective cap	Silicone/rubber	
Installation	laterally to the two mounting bores	

Dimensional drawing

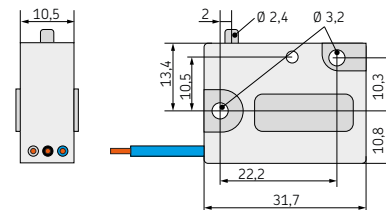

Electrical connection

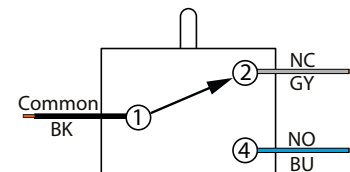

## 5. Delivery, returns, and storage

### 5.1 Delivery

After receipt of the shipment, check the shipment for damage and completeness according to the shipping documents. Immediately report any transport damages to the forwarding agent.

Keep the packaging material until any discrepancies are resolved. During in-house transport ensure safe handling.

### 5.2 Returns

Clean all parts and pack them properly (i.e. following the regulations of the recipient country) before returning them.

Protect the product against mechanical influences such as impacts. There are no restrictions for land, sea or air transport.

Mark returns on the packaging as follows.



### 5.3 Storage

SKF products are subject to the following storage conditions:

- dry, dust- and vibration-free in closed premises
- no corrosive, aggressive materials at the place of storage (e. g. UV rays, ozone)
- protected against pests and animals (insects, rodents, etc.)
- possibly in the original product packaging
- shielded from nearby sources of heat and coldness
- in case of high temperature fluctuations or high humidity take adequate measures (e. g. heater) to prevent the formation of condensation water



Before application inspect the products with regard to possible damages occurred during their storage. This particularly applies for parts made out of plastic (embrittlement).

### 5.4 Storage temperature range

- In case of parts not filled with lubricant the admissible storage temperature corresponds to that of the admissible operating temperature of the lubrication pump (see Technical data)
- In case of parts filled with lubricant the admissible storage temperature range is:

min. + 5 °C

max. + 35 °C



If the storage temperature range is not adhered to, the following work steps for replacing the lubricant may not in all cases lead to the desired result.

### 5.5 Storage conditions for parts filled with lubricant

The conditions mentioned in the following will have to be adhered to when storing products filled with lubricant,

#### 5.5.1 Storage period of up to 6 months

The filled products can be used without having to take further measures.

#### 5.5.2 Storage period from 6 to 18 months

##### Lubrication pump

- Connect the lubrication pump electrically
- Switch the lubrication pump on and let it run, e.g. by triggering an additional lubrication, until about 4 cm of lubricant will leak from each pump element
- Disconnect the lubrication pump from the power supply
- Remove and dispose of leaked lubricant

##### Metering device

- Remove all lubrication lines and closure screws, if any
- Connect the lubrication pump primed with new lubrication grease suitable for the application purpose to the metering device
- Let the lubrication pump run until new lubricant leaks from the outlets of the metering device/lubrication lines
- Remove leaked lubricant
- Reinstall closure screws where applicable

##### Feed lines

- Dismantle preassembled lubrication lines
- Ensure that both lubrication line ends remain open
- Prime lubrication lines with new lubricant

#### 5.5.3 Storage period exceeding 18 months

To avoid dysfunctions consult the manufacturer before commissioning. The general procedure to remove the old grease filling corresponds to that of a storage period from 6 to 18 months.

## 6. Installation

### 6.1 Prior to installation

Prior to installation observe the following points:

- Remove packaging material and closure plug, if any
- Install the metering device at a suitable place following the lubrication plan
- Mount the metering device together with the indicator pin in such way that the indicator pin is easily visible

### 6.2 Place of installation

Install the product protected against humidity and vibration and easily accessible to ensure all other installations can be carried out without any problem.

### 6.3 Prerequisites for the correct functioning of the metering devices

The following points must be observed during installation to ensure correct functioning and a trouble-free operation.

- The metering devices must be configured and mounted correctly
- All lubrication lines must be routed and mounted to the metering device correctly
- Each open outlet on the metering device must be secured by a suitable check valve.
- Metering devices with emergency lubrication fitting (SSV-E, SSVD-E) must additionally be secured at the inlet by a suitable check valve, as otherwise in case of an emergency lubrication (e.g. in case of a defective lubrication pump) the lubricant would first flow towards the lubrication pump due to the pressure conditions.
- Use adequate lubricant without contaminations only
- There must not be present any blockage in the progressive lubrication system or in the lubrication points
- Adhere to the stated tightening torques.
- In case of attached electrical components also observe the relevant IP types of protection
- A correct electrical function monitoring requires an adequate processing of the signal by a lubrication pump with control PCB or by an external control unit.
- The minimum operating pressure must be reached
- The maximum differential pressure must not be exceeded

## 6.4 Changing the metering volume internally

### 6.4.1 SSV, SSV-E, SSVL and SSVM metering devices

Closing unneeded outlets with closure screws (3) increases the output of the next lower open outlet on the same side by the lubricant volume of the upper closed outlets.

Per stroke and outlet:

approx. 0.2 cm (SSV, SSV-E and SSVL)

approx. 0.07 cm (SSVM)

of lubricant is supplied.

#### NOTICE

##### Damage to the superior machine

- For metering devices with indicator pin (monitoring K, KA, KN) the metering volume reduces following the specifications in the Technical data.
- Outlets marked with the following symbols must not be closed, as otherwise the metering device will block.



Maximum number of outlets that can be crossported internally per side of the metering device:

Metering device size 6 = 2

Metering device size 12 = 5

Metering device size 16 = 7

Metering device size 18 = 8

Metering device size 20 = 9

Metering device size 22 = 10

Further increasing of the output per outlet is possible only by an external combining, e.g. by means of a T-piece or by using metering devices with bypass bores.

#### NOTICE

##### Risk of damage to the superior machine and to the metering device

Closure screws on piston level must not be removed to change the output volume.

Fig. 18 Internal cross-porting

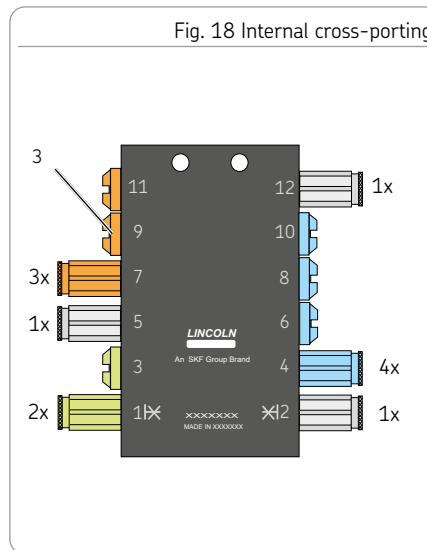

### 6.4.2 Metering devices with bypass bores

Metering devices with bypass bores are preferably used when an impair number of outlets is needed. In case of metering devices with bypass bores outlet numbers 1 and 2 are internally cross-ported (drilled with each other). By doing so and different from metering devices without bypass bores the output volume on metering device level 1-2 can be doubled at the opposite open outlet by closing one outlet (1 or 2).

Metering devices with bypass bore are marked with a double arrow.



#### Example SSVD

Outlet:	Metered volume
6 [open]	0.8 cm
5 [closed]	0.8 cm to outlet 3
4 [open]	0.6 cm
3 [open]	1.4 cm (0.6 cm + 0.8 cm from outlet 5)
2 [closed]	1.0 cm to outlet 1
1 [open]	2.0 cm (1.0 cm + 1.0 cm from outlet 2)

#### Example SSV

Outlets 5 and 3 internally cross-ported by a closure screw:

➔ Double lubricant volume on the same side at the next lower open outlet

Outlets 1 and 2 drilled with each other, outlet 2 closed:

➔ Double lubricant volume at the opposite side at outlet 1.

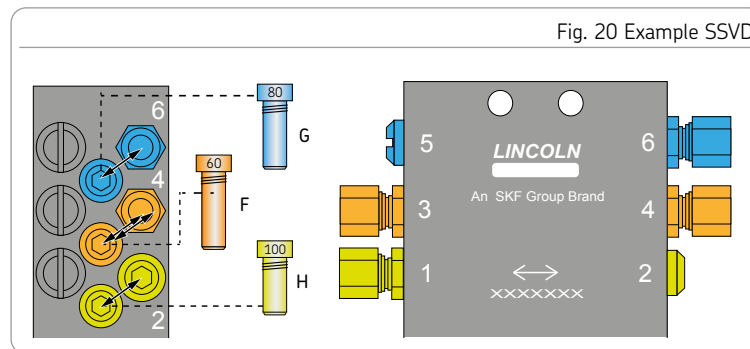
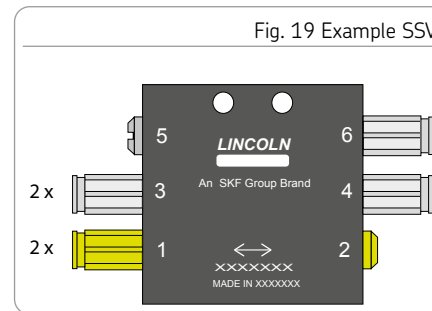

### 6.4.3 SSVD, SSVD-E and SSVDL metering devices

The output of the SSV, SSVD-E and SSVDL metering devices can be adapted by using different metering screws. An additional adaptation is possible by closing unneeded outlets with closure screws in case of SSVD and SSVD-E or by using connection bars in case of SSVDL metering devices

To change the output with metering screws proceed as follows:

- Remove protective caps from the metering device
- Screw the required metering screw into the corresponding outlet
- Repeat the procedure for all other outlets.

Tightening torques, see corresponding table in these instructions.

### 6.4.4 Counting sequence of the metering screws for preassembled metering devices

For pre-assembled metering devices, the positions of the metering screws are indicated in descending order always, i.e. the counting sequence starts at the metering piston level corresponding to the highest outlet number and continues in descending

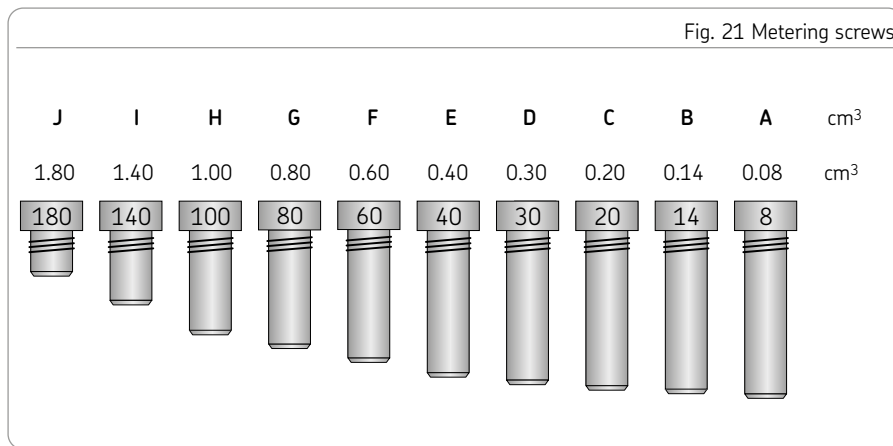

order to the metering piston level corresponding to the lowest outlet number. The metering screws are always mounted on the side with the even outlet numbers.

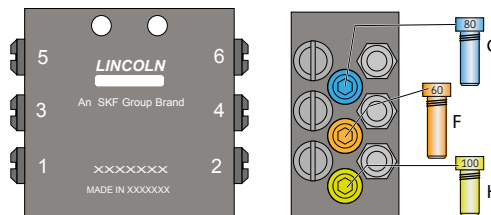

Example:  
 SSVDx6xxx-xx-GFHxxxxxxxx  
 (x = placeholder in type identification code) SSVD6 with metering screws GFH in the metering piston levels (medium levels) 6, 4, and 2:

### 6.5 External combination of the output in case of SSVL and SSVDL

#### NOTICE

##### Risk of damage to the superior machine due to poor supply

In case of SSVDL metering devices the outlets must not be closed directly at the metering device housing. Excepted from this are the SSVDL metering devices where outlets 1 and 2 are drilled with each other.

The external combination is realized via connecting bars (4). Connecting bars are available for the 2, 3, 4 and 5 times the output per outlet.

For external combination of the output, proceed as follows:

- If necessary, screw closure screws (3) or outlet fittings (5) out of the metering device.
- Select the required connecting bars and install them together with the USIT gaskets (2), closure screws (3) and check valves.

Fig. 22 SSVL metering devices with double and triple output

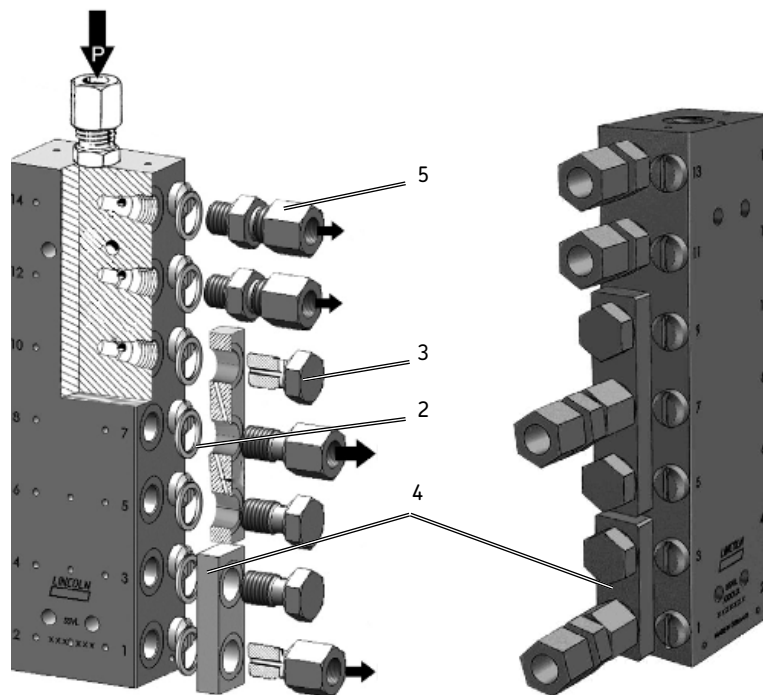



### 6.6 Fixation of the metering device at the place of installation

It is recommended to provide a free space of about 80 mm around the metering device for inspection and connection purposes. The described metering devices are fixed to 2 or 4 mounting bores.

For measures see table Size, dimensions and weights of the respective metering device.

#### Proceeding

Position the metering device to be mounted at the place of installation. Transfer the drill pattern and then make the corresponding bores.

Tightening torques, see corresponding table in these instructions

Fig. 23 Fixation of the metering device at the place of installation

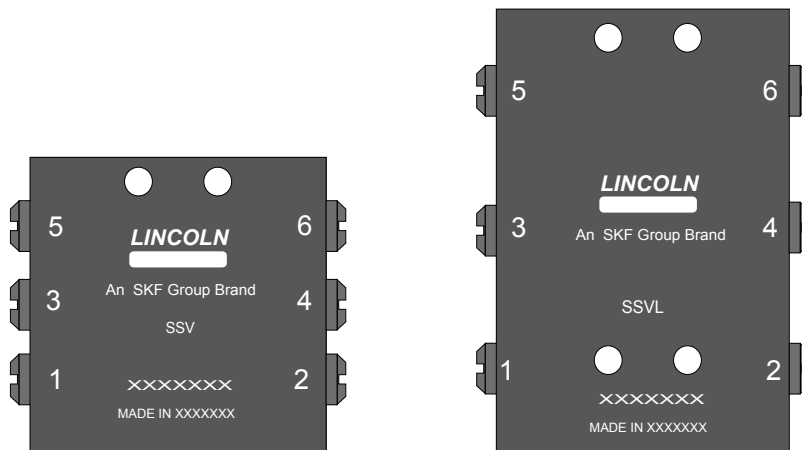

### 6.7 Optional mounting bracket for SSV, SSV-E, SSVD and SSVD-E

For metering device models SSV, SSV-E, SSVD and SSVD-E as of construction size 14 there exists the possibility to additionally fix them on their bottom side by a fixing angle. For this purpose the metering devices have two threaded bores on the bottom side. Fixation is done by means of two screws M5 x 8 and the corresponding washers. Tightening torque corresponding to screw size.

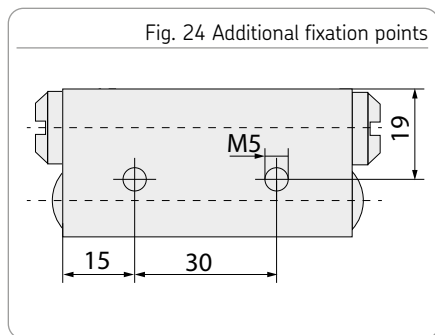

### 6.8 Venting of the SSV metering devices and the progressive lubrication system

- First of all configure the main metering device completely
- Connect the main lubrication line from the lubrication pump to the main metering device
- Let the lubrication pump run until lubrication grease leaks from all open outlets of the main metering device free from bubbles
- Mount the lubrication lines filled with lubrication grease from the main metering device to the completely configured secondary metering device
- Let the lubrication pump run until lubrication grease leaks from all open outlets of the main metering device free from bubbles
- Repeat the procedure on all other secondary metering devices
- Remove and dispose of leaked lubricant

## 7. Initial start-up

The start-up is effected in the frame of the initial start-up of the fully and correctly mounted progressive lubrication system.



## 8. Operation

SKF products operate automatically to the greatest possible extent. Basically, activities during standard operation of a progressive lubrication system are limited to the control of the filling level of the lubrication pump in use and the timely refilling of lubricant.

7

8

## 9. Cleaning

	 <b>WARNING</b>
	<p><b>Electric shock</b></p> <p>Carry out cleaning works only on depressurized products that have been disconnected from the power supply. Do not touch cables or electrical components with wet or damp hands.</p> <p>Performance of cleaning, required personal protective equipment, cleaning agents and devices following the valid operational regulations of the operator.</p>

### 9.1 Cleaning agents

Cleaning agents compatible with the material may be used only. (Materials, see chapter 2.3).



Thoroughly remove residues of cleaning agents from the product and rinse off with clear water.

### 9.2 Exterior cleaning

- Mark and secure wet areas
- Keep unauthorized persons away
- Thorough cleaning of all outer surfaces with a damp cloth

### 9.3 Interior cleaning

Normally, interior cleaning is not required. Should incorrect or contaminated lubricant have been filled, inside cleaning of the product will be required. To do so, contact the SKF Customer Service.

## 10. Maintenance

Regular and appropriate maintenance is a prerequisite to detect and clear faults in time. The specific time lines have to be determined, verified at regular intervals and adapted, if necessary, by the operator based on the operating conditions. If needed, copy the table for regular maintenance activities.

Fig. 25 Maintenance check list

Activity to be done	YES	NO
All components, such as e.g. lubrication lines and adapters, have been correctly installed	<input type="checkbox"/>	<input type="checkbox"/>
No visible damage, contamination and corrosion	<input type="checkbox"/>	<input type="checkbox"/>
Any dismantled protection and monitoring equipment has been reassembled and checked for correct function	<input type="checkbox"/>	<input type="checkbox"/>
No unusual noises, vibrations, accumulation of moisture, or odours present	<input type="checkbox"/>	<input type="checkbox"/>
No unwanted escape of lubricant (leakages) from connections	<input type="checkbox"/>	<input type="checkbox"/>
Bearings and friction points are provided with the planned amount of lubricant	<input type="checkbox"/>	<input type="checkbox"/>

## 11. Troubleshooting

Fig. 26 Fault table 1



In addition to the indications regarding troubleshooting stated here, observe all indications regarding troubleshooting stated in the lubrication pump instructions. To check the individual outlets you may have to run the lubrication pump for a longer period of time as the single outlets are provided with lubricant one after the other and thus there may be required several cycles of the upstream metering device. If the fault cannot be determined and remedied, contact our Customer Service.

Fault	Possible cause	Remedy
Poor or excessive lubrication of all lube points	<ul style="list-style-type: none"> <li>○ Wrong setting of lubrication time or pause time on the lubrication pump</li> </ul>	<ul style="list-style-type: none"> <li>○ Check and, if necessary, correct lubrication and pause times</li> </ul>
Poor or excessive lubrication of individual lubrication points	<ul style="list-style-type: none"> <li>○ Wrong output setting on the metering device</li> </ul>	<ul style="list-style-type: none"> <li>○ Check the output settings for compliance with the specifications. If needed, correct the output settings.</li> </ul>
Poor lubrication of individual lubrication points	<ul style="list-style-type: none"> <li>○ Wrong output setting on the metering device</li> <li>○ No check valve mounted to the metering device outlet</li> </ul>	<ul style="list-style-type: none"> <li>○ Check and, if necessary, mount check valve or replace defective check valve.</li> <li>○ Check the output settings for compliance with the specifications. If needed, correct the output settings.</li> </ul>

Fig. 27 Fault table 2

Fault	Possible cause	Remedy
<ul style="list-style-type: none"> <li>○ Poor lubrication of all lubrication points</li> </ul>	<ul style="list-style-type: none"> <li>○ Blockade upstream of the main metering device</li> </ul>	<ul style="list-style-type: none"> <li>○ Loosen the lubrication line to the main metering device. If after loosening the lubrication line there is no lubricant output from the line, then the problem is located either in the lubrication line to the main metering device or in the lubrication pump.</li> </ul>
<ul style="list-style-type: none"> <li>○ Poor lubrication of all lubrication points</li> </ul>	<ul style="list-style-type: none"> <li>○ Main metering device clogged</li> </ul>	<ul style="list-style-type: none"> <li>○ Loosen the lubrication lines from the main metering device to the secondary metering devices one after the other. If after loosening the lubrication lines there is no lubricant output from the main metering device, then the problem is located either in the main metering device or in its feed line. Clean and, if necessary, replace the proximity switch.</li> </ul>
<ul style="list-style-type: none"> <li>○ Poor lubrication of individual lubrication points</li> </ul>	<ul style="list-style-type: none"> <li>○ Secondary metering device clogged.</li> </ul>	<ul style="list-style-type: none"> <li>○ Loosen the lubrication lines from the main metering device to the secondary metering devices one after the other. If after loosening a lubrication line there leaks lubricant from the outlet of the main metering device, then the problem is located in the corresponding lubrication circuit of the secondary metering device. Clean and, if necessary, replace the secondary metering device.</li> </ul>
<ul style="list-style-type: none"> <li>○ Poor lubrication of individual lubrication points</li> </ul>	<ul style="list-style-type: none"> <li>○ Blockade on a lubrication point</li> </ul>	<ul style="list-style-type: none"> <li>○ Loosen the lubrication lines from the secondary metering device to the lubrication points one after the other. If after loosening a lubrication line there leaks lubricant from the outlet of the secondary metering device, then the problem is located in the corresponding lubrication point or lubrication line of the secondary metering device.</li> </ul>

## 12. Repair

### 12.1 Remediating a blockade

#### NOTICE

##### Damage to the machine

Make sure to eliminate any blockades. Until elimination switch off the machine or, if possible:

- Use a grease gun to provide lubrication points with sufficient lubricant
- If the blockade is positioned upstream to the secondary metering devices, you may carry out an emergency lubrication (SSV-E and SSVD-E).

- When used with piston detector/proximity switch/limit switch fault indication/fault message on the pump with control unit or on the external control unit

To remedy a blockade proceed as described in chapter Troubleshooting. After remediating the fault check the progressive lubrication system with regard to safety and function.

**Blockades in a progressive lubrication system can be detected as follows:**

- Lubricant leaking from the pressure control valve of the lubrication pump

If any

- Indicator pin on metering device does not move
- No signal of the electrical function monitoring within the defined monitoring time



## 13. Shutdown and disposal

### 13.1 Temporary shutdown

Temporarily shut the system down by:

- Switching off the superior machine

### 13.2 Final shutdown and disassembly

The final shutdown and disassembly of the product must be planned and carried out by the operator in a professional manner and in compliance with all regulations to be observed.

### 13.3 Disposal

#### Countries within the European Union

Disposal should be avoided or minimized wherever possible. Disposal of products contaminated with lubricant must be effected via licensed waste disposal contractor in accordance with environmental requirements and waste disposal regulations as well as local authority requirements.



The specific classification of the waste is in the waste producer's responsibility, as the European Waste Catalogue provides different waste disposal codes for the same type of waste but of different origin.

#### Electrical components

have to be disposed of or recycled following WEEE directive 2012/19/EU.

#### Plastic or metal parts

can be disposed of with the commercial waste.

#### Countries outside the European Union

The disposal has to be done according to the valid national regulations and laws of the country where the product is used.

## 14. Selection of metering devices / spare parts

### 14.1 SSV dividers

Standard version, black galvanized

Designation	Qty.	Part number
SSV 6	1	619-26473-1
SSV 8	1	619-25730-2
SSV 10	1	619-26841-1
SSV 12	1	619-25731-2
SSV 14	1	619-28862-1
SSV 16	1	619-28863-1
SSV 18	1	619-28864-1
SSV 20	1	619-28865-1
SSV 22	1	619-28866-1

with indicator pin, black galvanized

Designation	Qty.	Part number
SSV 6-K	1	619-26474-3
SSV 8-K	1	619-25754-4
SSV 10-K	1	619-26842-2
SSV 12-K	1	619-25755-4
SSV 14-K	1	619-28871-1
SSV 16-K	1	619-28872-1
SSV 18-K	1	619-28873-1
SSV 20-K	1	619-28874-1
SSV 22-K	1	619-28875-1

other metering devices on request

Standard version, stainless steel 1.4305 (V2A)

Designation	Qty.	Part number
SSV 6 (VA 1.4305)	1	619-27471-1
SSV 8 (VA 1.4305)	1	619-27473-1
SSV 10 (VA 1.4305)	1	619-27475-1
SSV 12 (VA 1.4305)	1	619-27477-1
SSV 14 (VA 1.4305)	1	619-29063-1
SSV 16 (VA 1.4305)	1	619-29064-1
SSV 18 (VA 1.4305)	1	619-29065-1
SSV 20 (VA 1.4305)	1	619-29066-1
SSV 22 (VA 1.4305)	1	619-29775-1

with indicator pin, stainless steel 1.4305 (V2A)

Designation	Qty.	Part number
SSV 6-K (VA 1.4305)	1	619-27472-1
SSV 8-K (VA 1.4305)	1	619-27474-1
SSV 10-K (VA 1.4305)	1	619-27476-1
SSV 12-K (VA 1.4305)	1	619-27478-1
SSV 14-K (VA 1.4305)	1	619-29067-1
SSV 16-K (VA 1.4305)	1	619-29068-1
SSV 18-K (VA 1.4305)	1	619-29069-1
SSV 20-K (VA 1.4305)	1	619-29074-1
SSV 22-K (VA 1.4305)	1	619-77910-1

Standard version, stainless steel 1.4571 (V4A)

Designation	Qty.	Part number
SSV 6 (VA 1.4571)	1	619-27824-1
SSV 8 (VA 1.4571)	1	619-27825-1
SSV 10 (VA 1.4571)	1	619-27889-1
SSV 12 (VA 1.4571)	1	619-27900-1

with indicator pin, proximity switch (without cable) stainless steel 1.4305 (V2A)

Designation	Qty.	Part number
SSV 6-KN (VA 1.4305)	1	619-27633-1
SSV 8-KN (VA 1.4305)	1	619-27634-1
SSV 10-KN (VA 1.4305)	1	619-27635-1
SSV 12-KN (VA 1.4305)	1	619-27636-1

with indicator, proximity switch (PNP) with  
3 m cable and ferrules

Designation	Qty.	Part number
SSV 6-KN	1	619-27613-1
SSV 8-KN	1	619-27614-1
SSV 10-KN	1	619-27615-1
SSV 12-KN	1	619-27616-1
SSV 14-KN	1	619-29028-1
SSV 16-KN	1	619-28905-1
SSV 18-KN	1	619-28959-1
SSV 20-KN	1	619-28934-1

with indicator, proximity switch (NPN) with  
3 m cable and ferrules

Designation	Qty.	Part number
SSV 6-KN	1	619-27953-1
SSV 8-KN	1	619-27918-1
SSV 10-KN	1	619-27961-1
SSV 12-KN	1	619-27962-1

with indicator pin, limit switch and 1 m cable

Designation	Qty.	Part number
SSV 6-KS	1	619-27074-1
SSV 8-KS	1	619-27070-1
SSV 10-KS	1	619-27069-1
SSV 12-KS	1	619-27068-1
SSV 16-KS	1	619-28906-1
SSV 20-KS	1	619-28936-1

With piston detector, 3 m cable and ferrules

Designation	Qty.	Part number
SSV 6-N (10-36 VDC)	1	619-28257-1
SSV 8-N (10-36 VDC)	1	619-28258-1
SSV 10-N (10-36 VDC)	1	619-28259-1
SSV 12-N (10-36 VDC)	1	619-28260-1
SSV 14-N (10-36 VDC)	1	619-28890-1
SSV 16-N (10-36 VDC)	1	619-28907-1
SSV 18-N (10-36 VDC)	1	619-28957-1
SSV 20-N (10-36 VDC)	1	619-28935-1
SSV 22-N (10-36 VDC)	1	619-29015-1

With piston detector, 3 m cable with bayonet plug,  
4/2 A-coded

Designation	Qty.	Part number
SSV 6-NE (10-36 VDC)	1	619-29155-1
SSV 8-NE (10-36 VDC)	1	619-29144-1
SSV 10-NE (10-36 VDC)	1	619-29145-1
SSV 12-NE (10-36 VDC)	1	619-29146-1

With piston detector, 3 m cable with AMP plug

Designation	Qty.	Part number
SSV 6-N (10-36 VDC)	1	619-28521-1
SSV 8-N (10-36 VDC)	1	619-28746-1
SSV 10-N (10-36 VDC)	1	619-28747-1
SSV 18-N (10-36 VDC)	1	619-29108-1

## 14.2 SSV-E metering devices

Standard version, black galvanized

Designation	Qty.	Part number
SSV 6-E	1	619-77345-1
SSV 8-E	1	619-77346-1
SSV 10-E	1	619-77347-1
SSV 12-E	1	619-77348-1
SSV 14-E	1	619-77349-1
SSV 16-E	1	619-77350-1
SSV 18-E	1	619-77351-1
SSV 20-E	1	619-77352-1
SSV 22-E	1	619-77353-1

With indicator pin and proximity switch (without cable) black galvanized

Designation	Qty.	Part number
SSV 6-E-KN	1	619-77446-1
SSV 8-E-KN	1	619-77447-1
SSV 10-E-KN	1	619-77448-1
SSV 12-E-KN	1	619-77449-1
SSV 14-E-KN	1	619-77450-1
SSV 16-E-KN	1	619-77451-1
SSV 18-E-KN	1	619-77452-1
SSV 20-E-KN	1	619-77453-1
SSV 22-E-KN	1	619-77454-1

Standard version, stainless steel 1.4305 (V2A)

Designation	Qty.	Part number
SSV 6-E (VA 1.4305)	1	619-77680-1
SSV 8-E (VA 1.4305)	1	619-77681-1
SSV 10-E (VA 1.4305)	1	619-77682-1
SSV 12-E (VA 1.4305)	1	619-77683-1
SSV 14-E (VA 1.4305)	1	619-77684-1
SSV 16-E (VA 1.4305)	1	619-77685-1
SSV 18-E (VA 1.4305)	1	619-77686-1
SSV 20-E (VA 1.4305)	1	619-77687-1
SSV 22-E (VA 1.4305)	1	619-77688-1

with indicator pin, proximity switch with 3 m cable and ferrules

Designation	Qty.	Part number
SSV 6/1-E-V1-N	1	619-46986-1
SSV 6-E-N	1	619-77986-1
SSV 6-E-N (VA 1.4305)	1	619-77928-1
SSV 8-E-N (VA 1.4305)	1	619-77929-1
SSV 10-E-N (VA 1.4305)	1	619-77930-1

with indicator pin, black galvanized

Designation	Qty.	Part number
SSV 6-E-K	1	619-77354-1
SSV 8-E-K	1	619-77355-1
SSV 10-E-K	1	619-77356-1
SSV 12-E-K	1	619-77357-1
SSV 14-E-K	1	619-77358-1
SSV 16-E-K	1	619-77359-1
SSV 18-E-K	1	619-77360-1
SSV 20-E-K	1	619-77361-1
SSV 22-E-K	1	619-77362-1

### 14.3 SSVD metering devices

Standard version, black galvanized

Designation	Qty.	Part number
SSVD 6	1	649-29485-1
SSVD 8	1	649-29486-1
SSVD10	1	649-29487-1
SSVD12	1	649-29488-1
SSVD14	1	649-29489-1
SSVD16	1	649-29587-1
SSVD18	1	649-29588-1
SSVD20	1	649-29589-1
SSVD22	1	649-29590-1

With bypass bore, black galvanized

Designation	Qty.	Part number
SSVD 6/5 V1	1	649-29490-1
SSVD 8/7 V1	1	649-29491-1
SSVD10/9 V1	1	649-29492-1
SSVD12/11 V1	1	649-29493-1
SSVD14/13 V1	1	649-29494-1
SSVD16/15 V1	1	649-29591-1
SSVD18/17 V1	1	649-29592-1
SSVD20/19 V1	1	649-29593-1
SSVD22/21 V1	1	649-29594-1

with indicator pin, black galvanized

Designation	Qty.	Part number
SSVD 6 -.-.....-K	1	649-29505-1
SSVD 8 -.-.....-K	1	649-29506-1
SSVD10 -.-.....-K	1	649-29507-1
SSVD12 -.-.....-K	1	649-29508-1
SSVD14 -.-.....-K	1	649-29509-1
SSVD16 -.-.....-K	1	649-29595-1
SSVD18 -.-.....-K	1	649-29596-1
SSVD20 -.-.....-K	1	649-29597-1
SSVD22 -.-.....-K	1	649-29598-1

With indicator pin and proximity switch, black galvanized

Designation	Qty.	Part number
SSVD 6 -.-.....-KN	1	649-29515-1
SSVD 8 -.-.....-KN	1	649-29516-1
SSVD10 -.-.....-KN	1	649-29517-1
SSVD12 -.-.....-KN	1	649-29518-1
SSVD14 -.-.....-KN	1	649-29519-1
SSVD16 -.-.....-KN	1	649-29603-1
SSVD18 -.-.....-KN	1	649-29604-1
SSVD20 -.-.....-KN	1	649-29605-1
SSVD22 -.-.....-KN	1	649-29606-1

With indicator pin and bypass bore, black galvanized

Designation	Qty.	Part number
SSVD 6/5 -V1-.....-K	1	649-29510-1
SSVD 8/7 -V1-.....-K	1	649-29511-1
SSVD10/9 -V1-.....-K	1	649-29512-1
SSVD12/11 -V1-.....-K	1	649-29513-1
SSVD16/15 -V1-.....-K	1	649-29599-1
SSVD18/17 -V1-.....-K	1	649-29600-1
SSVD20/19 -V1-.....-K	1	649-29601-1
SSVD22/21 -V1-.....-K	1	649-29602-1

With indicator pin, proximity switch and bypass bore, black galvanized

Designation	Qty.	Part number
SSVD 6/5 -V1-.....-KN	1	649-29520-1
SSVD 8/7 -V1-.....-KN	1	649-29521-1
SSVD10/9 -V1-.....-KN	1	649-29522-1
SSVD12/11 -V1-.....-KN	1	649-29523-1
SSVD14/13 -V1-.....-KN	1	649-29524-1
SSVD16/15 -V1-.....-KN	1	649-29607-1
SSVD18/17 -V1-.....-KN	1	649-29608-1
SSVD20/19 -V1-.....-KN	1	649-29609-1
SSVD22/21 -V1-.....-KN	1	649-29610-1

With piston detector and bayonet plug with 3 m cable, black galvanized

Designation	Qty.	Part number
SSVD 6 -.-.....-NE	1	649-29706-1
SSVD 8 -.-.....-NE	1	649-29707-1
SSVD10 -.-.....-NE	1	649-29708-1
SSVD12 -.-.....-NE	1	649-29709-1
SSVD14 -.-.....-NE	1	649-29710-1
SSVD16 -.-.....-NE	1	649-29711-1
SSVD18 -.-.....-NE	1	649-29712-1
SSVD20 -.-.....-NE	1	649-29713-1
SSVD22 -.-.....-NE	1	649-29714-1

with piston detector, black galvanized

Designation	Qty.	Part number
SSVD 6 -.-.....-NP	1	649-29525-1
SSVD 8 -.-.....-NP	1	649-29526-1
SSVD10 -.-.....-NP	1	649-29527-1
SSVD12 -.-.....-NP	1	649-29528-1
SSVD14 -.-.....-NP	1	649-29529-1
SSVD16 -.-.....-NP	1	649-29619-1
SSVD18 -.-.....-NP	1	649-29620-1
SSVD20 -.-.....-NP	1	649-29621-1
SSVD22 -.-.....-NP	1	649-29622-1

With piston detector, 3 m cable and ferrules, black galvanized

Designation	Qty.	Part number
SSVD 6 -.-.....-N	1	649-29495-1
SSVD 8 -.-.....-N	1	649-29496-1
SSVD10 -.-.....-N	1	649-29497-1
SSVD12 -.-.....-N	1	649-29498-1
SSVD14 -.-.....-N	1	649-29499-1
SSVD16 -.-.....-N	1	649-29611-1
SSVD18 -.-.....-N	1	649-29612-1
SSVD20 -.-.....-N	1	649-29613-1
SSVD22 -.-.....-N	1	649-29614-1

With indicator pin and bypass bore, black galvanized

Designation	Qty.	Part number
SSVD 6/5 -V1-.....-NP	1	649-29530-1
SSVD 8/7 -V1-.....-NP	1	649-29531-1
SSVD10/9 -V1-.....-NP	1	649-29532-1
SSVD12/11 -V1-.....-NP	1	649-29533-1
SSVD14/13 -V1-.....-NP	1	649-29534-1
SSVD16/15 -V1-.....-NP	1	649-29623-1
SSVD18/17 -V1-.....-NP	1	649-29624-1
SSVD20/19 -V1-.....-NP	1	649-29625-1
SSVD22/21 -V1-.....-NP	1	649-29626-1

With piston detector, 3 m cable with ferrules and bypass bore, black galvanized

Designation	Qty.	Part number
SSVD 6/5 -V1-.....-N	1	649-29500-1
SSVD 8/7 -V1-.....-N	1	649-29501-1
SSVD10/9 -V1-.....-N	1	649-29502-1
SSVD12/11 -V1-.....-N	1	649-29503-1
SSVD14/13 -V1-.....-N	1	649-29504-1
SSVD16/15 -V1-.....-N	1	649-29615-1
SSVD18/17 -V1-.....-N	1	649-29616-1
SSVD20/19 -V1-.....-N	1	649-29617-1
SSVD22/21 -V1-.....-N	1	649-29618-1

#### 14.4 SSVL metering devices

Standard version, black galvanized

Designation	Qty.	Part number
SSVL 6	1	619-77162-1
SSVL 8	1	619-77163-1
SSVL10	1	619-77164-1
SSVL12	1	619-77165-1
SSVL14	1	619-77166-1

with indicator pin, black galvanized

Designation	Qty.	Part number
SSVL 6-K	1	619-77231-1
SSVL 8-K	1	619-77232-1
SSVL10-K	1	619-77233-1
SSVL12-K	1	619-77234-1
SSVL14-K	1	619-77235-1

with bypass bore, black galvanized

Designation	Qty.	Part number
SSVL 6/5-V1	1	619-77311-1
SSVL 8/7-V1	1	619-77312-1
SSVL10/9-V1	1	619-77313-1
SSVL12/11-V1	1	619-77314-1
SSVL14/13-V1	1	619-77315-1

#### 14.5 SSVDL metering devices

Standard version, black galvanized

Designation	Qty.	Part number
SSVDL6	1	649-77167-1
SSVDL8	1	649-77168-1
SSVDL10	1	649-77169-1
SSVDL12	1	649-77170-1
SSVDL14	1	649-77171-1

with indicator pin, black galvanized

Designation	Qty.	Part number
SSVDL 6-K	1	649-77474-1
SSVDL 8-K	1	649-77475-1
SSVDL10-K	1	649-77476-1
SSVDL12-K	1	649-77477-1
SSVDL14-K	1	649-77478-1

with bypass bore, black galvanized

Designation	Qty.	Part number
SSVD L 6/5-V1	1	649-77464-1
SSVDL 8/7-V1	1	649-77466-1
SSVDL10/9-V1	1	649-77468-1
SSVDL12/11-V1	1	649-77470-1
SSVDL14/13-V1	1	649-77472-1

#### 14.6 SSV-M metering devices

Standard version, black galvanized

Designation	Qty.	Part number
SSVM 6	1	619-26761-1
SSVM 8	1	619-37044-1
SSVM10	1	619-26846-1
SSVM12	1	619-37049-1

with indicator pin, black galvanized

Designation	Qty.	Part number
SSVM 6-K	1	619-26762-3
SSVM 8-K	1	619-37045-3
SSVM 10-K	1	619-26847-2
SSVM 12-K	1	619-37050-3

#### 14.7 SSVD-E metering devices

Standard version, black galvanized

Designation	Qty.	Part number
SSVD 6-E	1	649-77394-1
SSVD 8-E	1	649-77395-1
SSVD10-E	1	649-77396-1
SSVD12-E	1	649-77397-1
SSVD14-E	1	649-77398-1
SSVD16-E	1	649-77399-1
SSVD18-E	1	649-77400-1
SSVD20-E	1	649-77401-1
SSVD22-E	1	649-77402-1

#### 14.8 Metering screws for SSVD, SSVD-E, SSVDL

Coding	Length [mm]	Metered volume [cm <sup>3</sup> /stroke]	Qty.	Part number
8/A	46.7	0.08	12	549-34254-1
14/B	45.9	0.14	12	549-34254-2
20/C	44.7	0.20	12	549-34254-3
30/D	42.7	0.30	12	549-34254-4
40/E	40.7	0.40	12	549-34254-5
60/F	36.7	0.60	12	549-34254-6
80/G	32.7	0.80	12	549-34254-7
100/H	28.7	1.00	12	549-34254-8
140/I	20.8	1.40	12	549-34254-9
180/y	12.8	1.80	12	549-34255-1

Set of respectively 2 metering screws of all sizes, black galvanized	20	549-34255-2
Set of respectively 2 metering screws of all sizes in VA 1.4571	20	549-34255-3

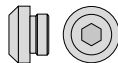
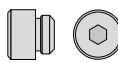

### 14.9 Outlet cap screws

Designation	Qty.	Part number		
Outlet cap screw with sealing edge for SSV, SSV-E, SSVD, SSVD-E	1	303-17499-3		
Outlet cap screw with sealing edge for SSVM	1	303-16284-1		

### 14.10 Mounting bracket SSV

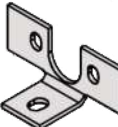
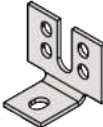
Designation	Qty.	Part number		
Mounting bracket SSV and SSV-E as of size 14	1	519-34271-1		
Mounting brackets SSVD and SSVD-E as of size 12	1	549-34269-1		
Delivery including fastening material				

### 14.11 Outlet fittings

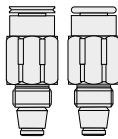
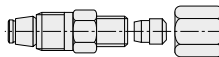
Designation	Qty.	Part number		
Push-in type fitting RV -6-M10x1-S01 Multi Pressure (tube Ø 6 mm)	1	226-14091-4		
Push-in type fitting RV 6511 -4-M8x1-S02 for SSVM (tube Ø 4 mm)	1	226-14091-5		
Screw-in fitting for SSV, SSV-E, SSVD (tube Ø 6 mm)	1	504-30344-4		
Screw-in fitting for SSVM with check valve (tube Ø 4mm)	1	519-31661-1		

### 14.12 Hydraulic lubrication fitting

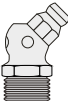
Designation	Qty.	Part number	
Hydraulic lubrication fitting B R 1/8 Z	1	251-14045-1	

### 14.13 Universal piston detector

Designation	Qty.	Part number
Universal piston detector with adapter and O-ring	1	519-85224-1
Universal piston detector with adapter and O-ring and 3 m cable (2-core)	1	664-85282-7
Universal piston detector with adapter and O-ring and 5 m cable (2-core)	1	664-85282-8
Universal piston detector with adapter and O-ring and 7 m cable with bayonet plug (4/2-core)	1	664-85242-5
Other kits on request		

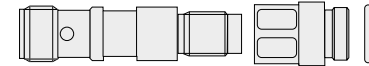

### 14.14 Inlet fittings

for SSV, SSV-E, SSVM, SSVD, SSVD-E

Designation	Qty.	Part number
Fitting GE 6 LLR 1/8 K	1	223-12270-7
Fitting GE 8 LLR 1/8 K	1	223-12270-9
Push-in type fitting GEKM 6510-6-1/8-S01	1	226-10622-8

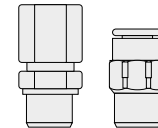

for SSVL, SSVDL

Fitting GE 8 L G1/4 A	1	223-12477-6
Fitting GE 10 L G1/4 A	1	223-12272-9

### 14.15 Outlet fittings for SSVL and SSVDL

Designation	Qty.	Part number
Outlet fitting GERV 8 L G1/4A (tube Ø 8 mm)	1	223-13052-2
Outlet fitting GERV10 L G1/4A (tube Ø 10 mm)	1	223-13052-3
Outlet fitting GERV12 L G 1/4A (tube Ø 12 mm)	1	223-13052-5

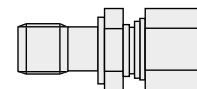

### 14.16 Outlet fittings for SSVL and SSVDL with check valve for connection bar

Designation	Qty.	Part number
Outlet fitting with check valve (tube Ø 8 mm)	1	504-33659-1
Outlet fitting with check valve (tube Ø 10 mm)	1	504-33660-1
Outlet fitting with check valve (tube Ø 12 mm)	1	504-33661-1

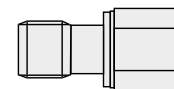

### 14.17 Cross-porting of outlets for SSVL and SSVDL

Designation	Qty.	Part number
Double cross-porting of outlets	1	519-34643-1
Triple cross-porting of outlets	1	519-34643-2
Quadruple cross-porting of outlets	1	519-34643-3
Quintuple cross-porting of outlets	1	519-34643-4
Delivery including the corresponding number of Usit rings and cap screws		

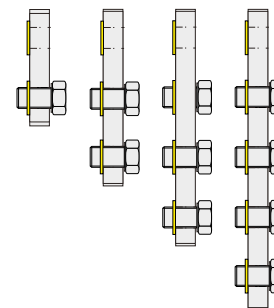

### 14.18 Cap screw G1/4 for SSVL and SSVDL

Designation	Qty.	Part number
Cap screw G1/4 for cross-porting of outlets of SSVL and SSVDL	1	303-16470-1

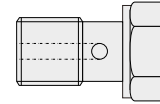

### 14.19 Sealing ring

Designation	Qty.	Part number
USIT sealing ring for cross-porting of outlets of SSVL and SSVDL	1	220-12238-9

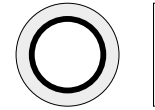

## Notes

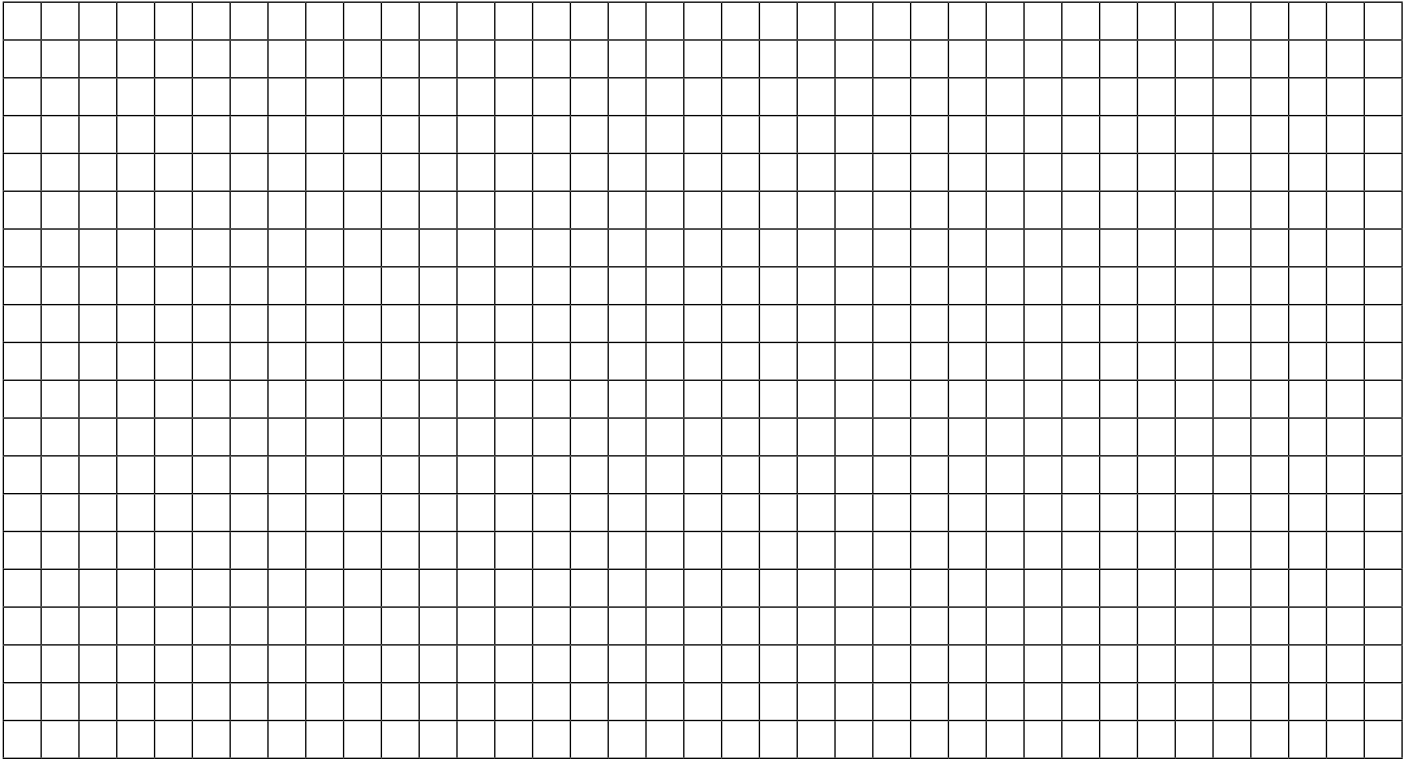

SKF Lubrication Systems Germany GmbH  
Walldorf Facilities  
Heinrich-Hertz-Straße 2-8  
D - 69190 Walldorf  
Tel:+49 (0) 6227 33-0  
Fax: +49 (0) 6227 33-259  
e-mail: [Lubrication-germany@skf.com](mailto:Lubrication-germany@skf.com)  
[www.skf.com/lubrication](http://www.skf.com/lubrication)

951-171-049-EN  
Version 08  
26/04/2023

