



Service Guide

31151-C 32301-C
 31152-C 32302-C
 31154-C 32304-C
 31159-C 32309-C

M-Series Oil Mist Generators

Description

These models of the M-Series Oil Mist Generators include:

- 3-Gallon (usable) powder coated reservoir
- Oil Level Sightglass w/ Thermometer
- Air Regulator and Filter
- Mist Pressure Gauge
- Oil Heater w/ High Temperature Limit Switch
- Hi-Lo Level and Refill Warning Switches
- Hi-Lo Mist Pressure Switches
- Stack Light (audible and visible)
- Automatic Oil Refill (pump not included)

Model Numbers provide voltage and nozzle identification:

- 1st digit = reservoir capacity
- 2nd, 3rd, & 4th digit = supply voltage
- 5th digit = Mist Nozzle Size
- 1 = 1 cfm (nominal)
- 2 = 2.3 cfm (nominal)
- 4 = 4.3 cfm (nominal)
- 9 = 9.7 cfm (nominal)

Example: 31154-C = 3 gallon, 115V, 4.3 cfm

Oil Mist Lubrication System

A “system” consists of a Mist Generator, mist distribution (header) piping, and mist “reclassifier” fittings (to convert the oil mist into a usable state at the point of lubrication). Attention to the recommended installation practices (see pages 6 through 8) will insure the desired lubrication results.

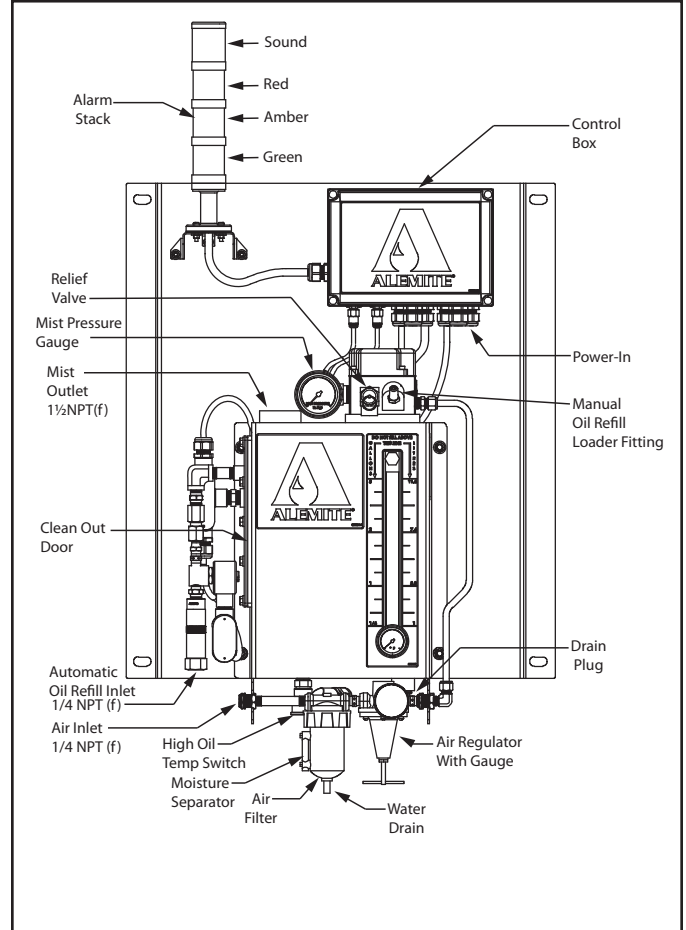

Figure 1 M-Series Oil Mist Generator (-C Models)

MODEL	NOZZLE OUTPUT(NOMINAL)		VOLTAGE (NOMINAL) Vac	CURRENT (NOMINAL) Amp
	cfm	l/m		
31151-C	1.0	28	120	4
31152-C	2.3	65		
31154-C	4.3	122		
31159-C	9.7	275		
32301-C	1.0	28	240	2
32302-C	2.3	65		
32304-C	4.3	122		
32309-C	9.7	275		

Table 1 Model Identification Chart

Alemite, LLC
 167 Roweland Drive, Johnson City, Tennessee 37601
 www.alemite.com

Copyright © 2012 by Alemite, LLC

This document contains confidential information that is the property of Alemite, LLC and is not to be copied, used, or disclosed to others without express written permission.

SER 31151-C
 Revision (6-12)

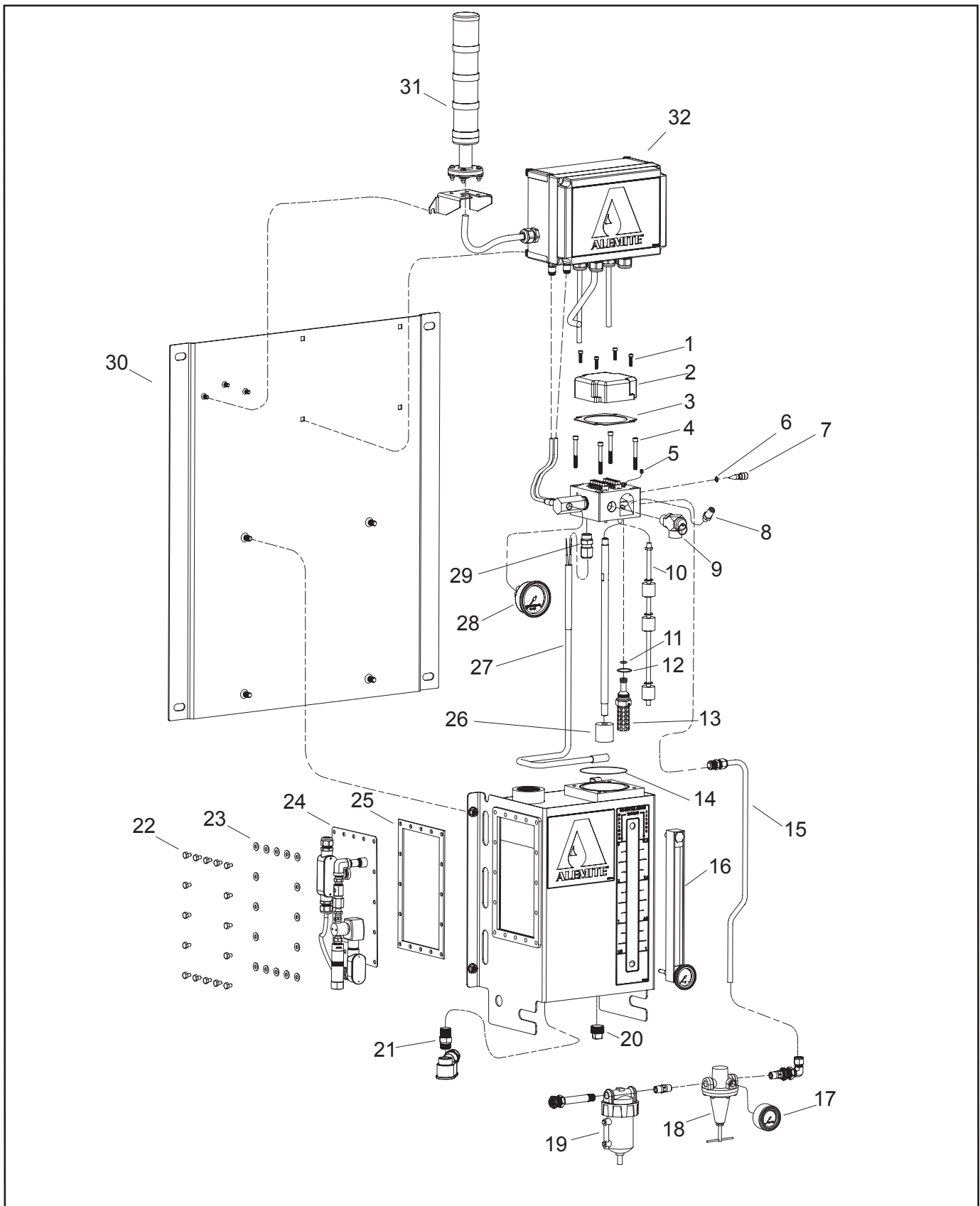

Figure 2 M-Series Oil Mist Generator (-C models) - exploded view

ITEM No.	PART No.	DESCRIPTION	Qty.	NOTES	
1		Screw, #10-32 x 5/8"	4	●	
2		Cover	1	●	
3		Gasket	1	● ■ □ ○ ◇ ◆	
4		Screw, 1/4"-20 x 2-1/4"	4		
5		Setscrew, #5-40 x 1/4"	1		
6		O-Ring, 1/4" ID x 3/8" OD	1	◆	
7	387366	Screw, Oil Adjustment	1		
8	387342	Valve, loader	1		
9	387345	Valve, safety relief	1		
10	388320	Switch, hi-lo level and refill warning	1		
11	X171018-12	O-ring, 3/8" ID x 1/2" OD	1	■ □ ○ ◇ ◆	
12	131266	Gasket, copper	1	■ □ ○ ◇ ◆	
13		Nozzle, 1.0 cfm (28 l/m)	1	■	Models 31151-C & 32301-C
		Nozzle, 2.3 cfm (65 l/m)	1	□	Models 31152-C & 32302-C
		Nozzle, 4.3 cfm (122 l/m)	1	○	Models 31154-C & 32304-C
		Nozzle, 9.7 cfm (275 l/m)	1	◇	Models 31159-C & 32309-C
14	171018-44	O-ring, 3 3/4" ID x 3 7/8" OD	1	◆	
15		Tube, air inlet	1		
16	387823	Gauge, Level/Temperature	1		
17	323449-4	Gauge, press. (0-200 psi.)	1		
18	7604-1	Air Regulator	1		Refer to SER 7604-1
19	5644-1	Air filter with aut drain	1		Refer to SER 5604-2
20		Pipe plug, 3/4" NPT	1		
21	388370	Switch, hi temp limit	1		
22		Screw, Hex Head 1/4"-20 x 1/2"	16		
23		Washer, Flat 1/4"	16		
24		Cleanout door with Automatic refill assembly	1		Refer to figure 4
25	388308	Gasket, cleanout door	1		
26	387295	Screen, inlet	1		
27	388322-1	Oil Heater, 120 Vac	1		
	388322-2	Oil Heater, 240 Vac	1		
28	384889	Gauge, press. (0-100 in. H ₂ O)	1		
29	387333	Connector, straight thread with o-ring	1		
30		Plate, mounting	1		
31	388384-1	Light, Stack 120 Vac	1		
	388384-2	Light, Stack 240 Vac	1		
32		Box, control	1		Refer to figure 3

Legend: Part numbers left blank are not available separately
 ● ■ □ ○ ◇ ◆ designates a repair kit item

Part numbers with an X prefix indicate a quantity of ten (10)

Repair Kits

Part No.	Kit Symbol	Description	Part No.	Kit Symbol	Description
393688	●	Cover Kit	393797-9	○	Nozzle Kit 4.3 cfm
393797-7	■	Nozzle Kit 1.0 cfm	393797-10	◇	Nozzle Kit 9.7 cfm
393797-8	□	Nozzle Kit 2.3 cfm	393806	◆	Seal Kit

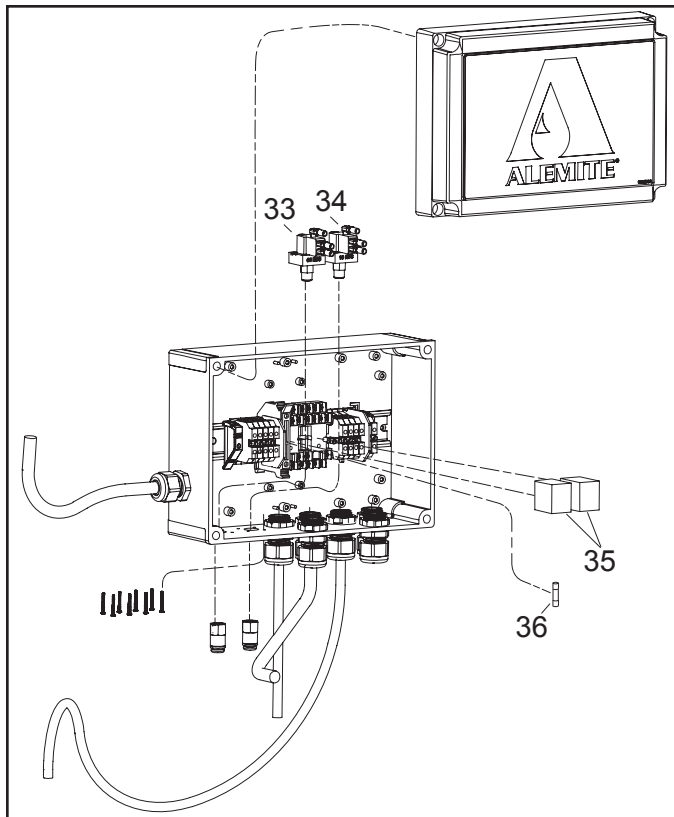

ITEM No.	PART No.	DESCRIPTION	Qty.
33	388337	Switch, mist high pressure, 50"-55" H ₂ O	1
34	388336	Switch, mist low pressure, 10"-15" H ₂ O	1
35	388323-1	Relay, dpdt 10A 120 Vac coil	2
	388323-2	Relay, dpdt 10A 240 Vac coil	2
36	393798-6	Fuse, 5x20mm 2A	1

Figure 3 Control Box Assembly - exploded view

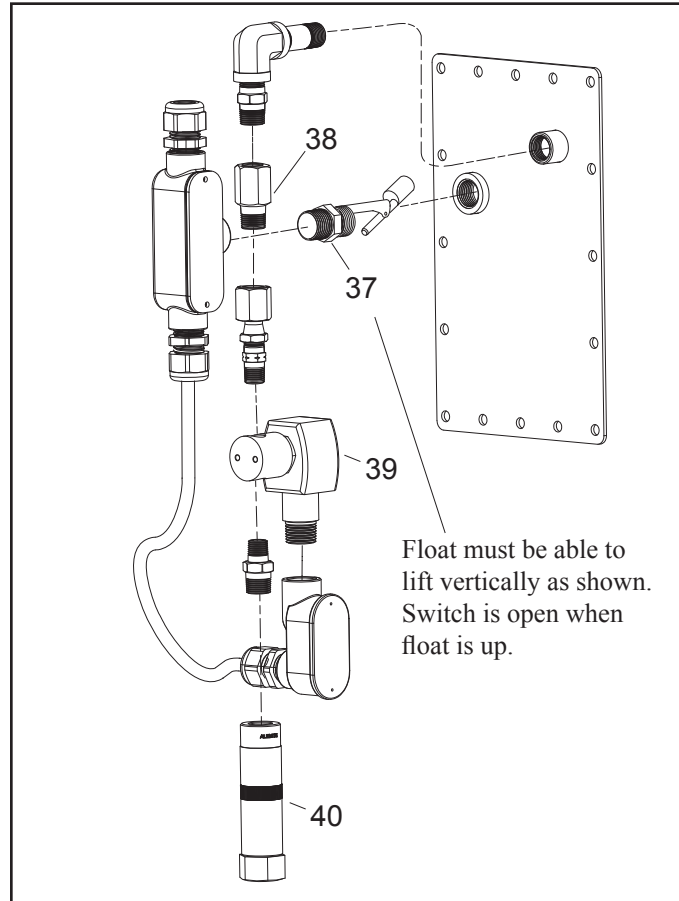

ITEM No.	PART No.	DESCRIPTION	Qty.
37	388315	Switch	1
38	338512-A	Check Valve	1
39	387449	Solenoid Valve, 240 Vac	1
	387449-1	Solenoid Valve, 120 Vac	1
40	338208	Filter Assembly (Refer to figure 5)	1

Figure 4 Automatic Refill Assembly - exploded view

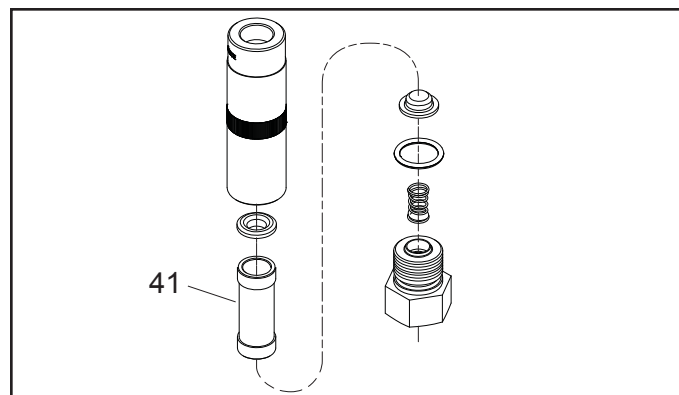

ITEM No.	PART No.	DESCRIPTION	Qty.
41	332964	Element, strainer (40 microns)	1

Figure 5 388208 Filter Assembly - exploded view

Specifications

Electrical Ratings:

Voltage: See Table 1.

Phase: 1 ph.

Frequency: 60 Hz.

Dimensions: 47" (119.4 cm) H x 26" (66 cm) W x 11" (28 cm) D

Reservoir:

Useful Oil Capacity: 3 gallons (11.4 liters)

Material: Carbon Steel

Finish: Powder Coated (color RAL7016)

Air Supply:

Pressure (min/max): 35/150 psi (2.5/10.5 kg/cm²)

Inlet Port Size 1/4 NPT (f)

Air Filter Media: 40 microns

Safety Relief Valve Pressure: 10 psi (0.7 Bar)

Oil Mist Generation Capacity: See Table 1

Oil Mist Outlet Port: 1 1/2 NPT (f)

Oil Heater:

Power: 165 Watts

Watt Density: 10 Watt/in² max.

Voltage: 120 Vac or 240 Vac

Temperature Control: Integrated Thermostat

Thermostat Setting: 105°F (41°C) (non-adjustable)

High Oil Temperature Switch:

Setting: 140°F (60°C) (non-adjustable)

Switch Type: SPDT

Process Port Size: 1/2 NPT

Hi-Lo Level and Refill Warning Float Switches:

Voltage Rating: 120/240Vac

Power: 50VA max.

Switch type: Top mounted, (3x) SPST

Process Port Size: 1/8 NPT

Mist Pressure Switches

Electrical Rating: 15A, 125/250 Vac

High Pressure Setting: 50"-55" H₂O

Low Pressure Setting: 10"-15" H₂O

Stack Light:

Voltage: 120 Vac or 240 Vac

Audible Module: 80 DB intermittent

Visible Modules:

Red: flashing

Amber: flashing

Green: continuous

General Safety

- Read all instructions carefully and thoroughly before operating, maintaining or servicing the unit.
- Be sure that electrical power supply conforms to the power requirement of the unit. Refer to "Specifications".
- Do not exceed pressure rating of system components.

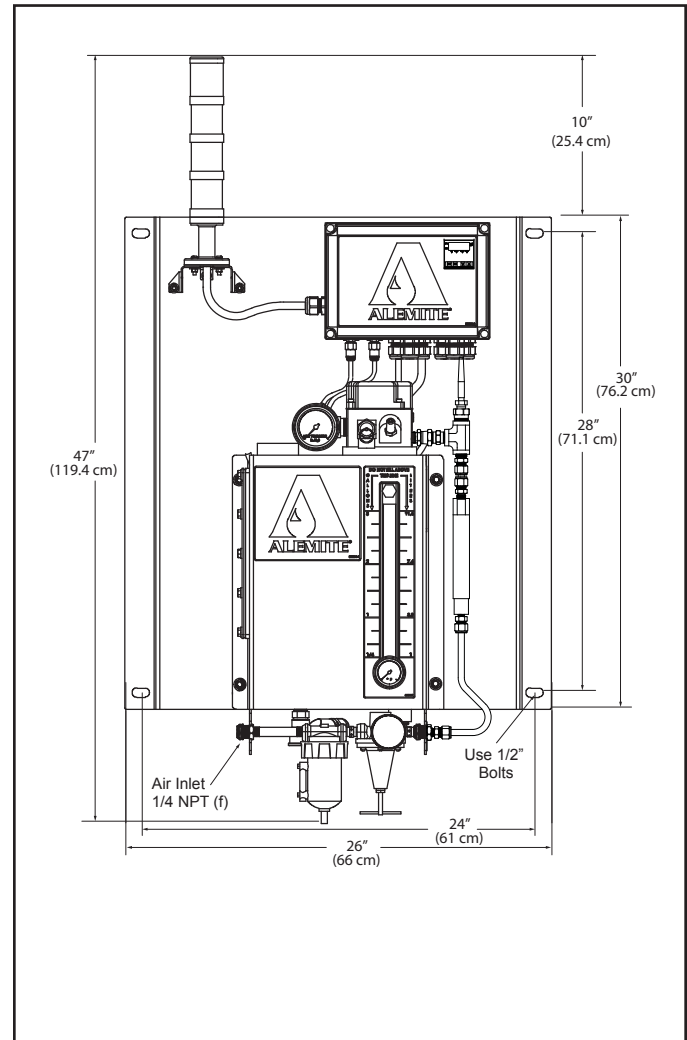

Figure 6 Mounting hole pattern

- Do not make system components adjustments that are not recommended in this service sheet. When in doubt, consult Alemite service representatives or personal familiar with instrumentation.
- Electrical service must be performed by an electrician or personnel familiar with instrumentation.
- Shut off electrical power and air supply to the unit before doing service on the unit.
- Protect air lines from damage or puncture, making certain that connections are secure.

Installation

General

The unit should be installed in an upright position and secure to the mounting surface using four 1/2" bolts (not included) inserted thru the slots on the back of the unit (see Figure 6).

A convenient location should be chosen for the installation such that sufficient room is allowed for installation of air, oil, and power lines and for reservoir clean out via access plate.

Note: Mounting the unit on a machine that vibrates excessively is NOT recommended.

Mist (Header) Pipe Sizing

CAUTION

Failure to follow the recommended guidelines for installing the oil mist distribution piping will create problems that will be difficult and expensive to correct. The most common cause of system problems/failure involve improper installation of piping.

The mist outlet port (1-1/2" NPT) is sized to allow for the maximum CFM output of the largest nozzle size available.

Restrictive mist pipe sizing can cause excessive mist pressure and oil condensation inside the piping. The minimum size outlet piping for each mist nozzle size is as follows:

Mist Nozzle	Min. Pipe / Tube Size
1.0 cfm	3/4" Sch 40 or 3/4" OD Tube
2.3 cfm	3/4" Sch 40 or 3/4" OD Tube
4.3 cfm	1" Sch 40 or 1" OD Tube
9.7 cfm	1-1/4" Sch 40

Mist (Header) Pipe "Slope"

The "oil mist" is produced by atomizing oil into a compressed air stream. The resulting mist resembles smoke and consists of a small amount of oil (in very tiny 1-3 micron size particles) mixed with a large volume of compressed air. Since the mixture is so "lean or dry", it is not flammable and can be transported great distances without excessive condensation inside the header pipe.

However, in any "system", a small amount of condensation will take place. It is critically important that the condensed oil drain (by gravity) back into the generator reservoir. Any condensate allowed to collect within the header system can cause problems and usually causes the mist pressure gauge to fluctuate.

Header piping should be installed with a "slope" of 1 inch per 20 feet of length (minimum). A "slope" of 1 inch per 10 feet of length is preferred, if possible. See Fig 7 for typical layout. Make sure header pipe is adequately supported to prevent future sags.

Instead of using pipe couplings to connect pipe sections, pipe tee's (with the open port facing upward) should be used. The unused port can either be plugged or connected to "drop lines". See details below.

All pipe threads should be sealed using pipe thread sealant, not tape. Leave the first 2 threads uncoated.

Shut-Off or block valves shall not be installed anywhere in the mist distribution piping system.

Drop Lines

At the various pieces of equipment requiring lubrication, a "drop line" should be installed, using a tee, to transport the mist from the header. To prevent any contaminants in the header from reaching the "reclassifier" fittings, these "drop lines" should emanate from the top of the header, not the bottom. Install the tee with the open port facing upward. Two 90° elbows can be used to direct the mist to the "reclassifier" fittings. "Drop line" pipe size should be 1/2" - 3/4" pipe or tube. See Fig 7 for typical layout.

All threaded pipe joints should be sealed with a pipe thread sealant (not tape).

Manifold Blocks & "Reclassifier" Fittings

Manifold blocks allow mist flow to be distributed to multiple "reclassifier" fittings from the "drop line". See Fig 7 for typical layout.

"Reclassifier" fittings are devices that contain small orifices & perform two critical functions in an oil mist system:

- A. They maintain (meter) system pressure
- B. They convert the "lean or dry" mist into a useful form by increasing the mist velocity and creating the turbulence required to cause the tiny oil particles to collide and form the larger droplets required for lubrication.

Each "reclassifier" fitting in the system has been carefully selected to permit a specific amount of mist to be delivered to each specific piece of equipment being lubricated. Even though they may look identical on the outside, they are different internally. Consult the system designer as what fitting should be installed on each piece of equipment. Omitting a fitting or installing the wrong fitting can cause equipment failure.

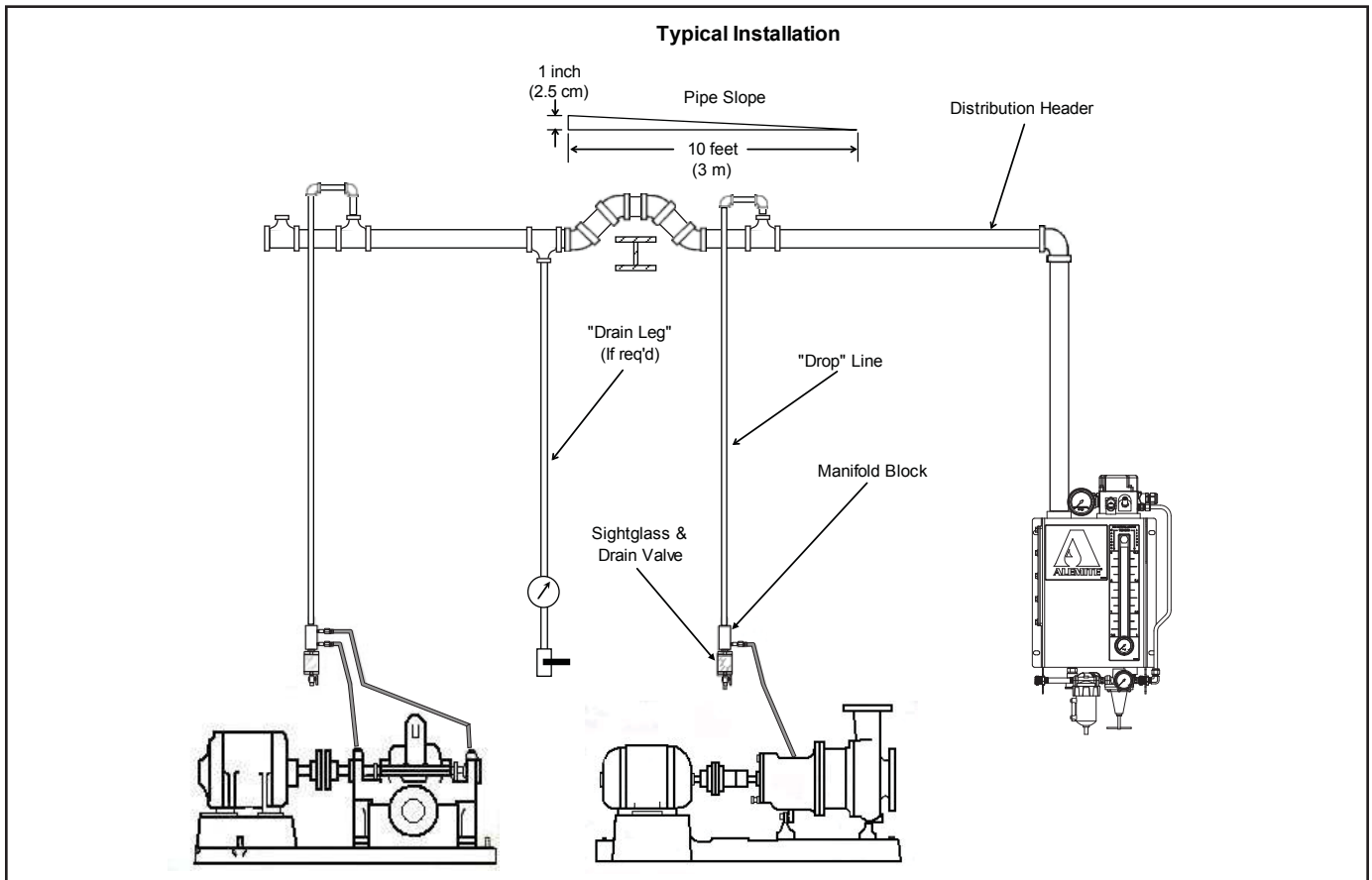

Figure 7 Typical Installation

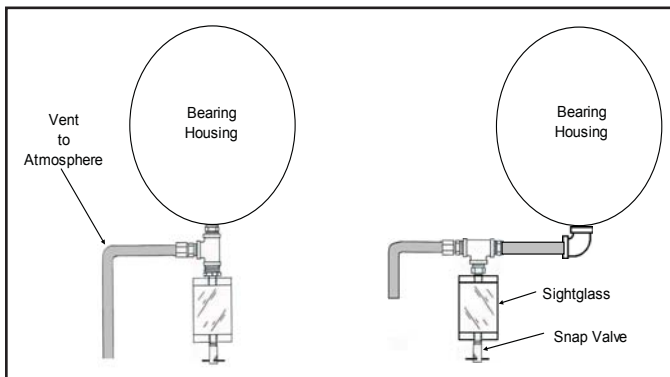

Figure 8 Vent & Drain

Vents and Drain

Successful lubrication of a ball or roller bearing in an enclosed housing requires a continuous flow of mist into and out of the housing. The mist flow cannot be “dead-headed”. For this reason, both a vent and a drain must be provided. The vent will assure continuous flow, while the drain will remove any nonconsumed oil that condenses in the bearing housing. See Fig 8 for typical methods of providing both vent and drain with one connection.

Air Supply

Clean, dry, regulated compressed air is required to operate an oil mist generator. Instrument-quality air is required.

A filter with automatic water drain (19) and a pressure regulator (18) are included with this oil mist generator.

The end-user should install an air shut-off valve prior to the filter (19) to isolate the generator when maintenance operations are performed. An air solenoid valve (not supplied) can be installed upstream of the shut-off valve if synchronization with machinery operation is desired.

All pipe threads should be sealed using pipe thread sealant, not tape. Leave the first 2 threads uncoated.

Electrical



CAUTION

In order to void personal injury or property damage, the electrical connections to the Oil Mist Generator unit must be performed by qualified personnel.

All models in the M-Series Oil Mist Generator come prewired from the factory to operate as a stand alone unit once power is installed.

1. The end user is responsible for installing a disconnect switch to turn the power to the unit ON or OFF as necessary according to applicable NEC, UL and local electrical codes.
2. Use a three-conductor jacketed cable with .39"-.56" OD that is appropriated for the environment where the unit is installed. The conductors should be sized properly according to applicable NEC, UL and local electrical codes.
3. Unscrew the four cover screws and carefully open the Control Box (32).
4. Loosen the cable gland reserved for the power cable as shown in Figure 9 and feed the power cable thru the cable gland. The spare glands shown in the figure can also be used.
5. Connect Line (L1), Neutral (N) and Ground (GND) to the unit as per Figure 10.
 - A. The L1 conductor (hot wire) should be connected to the empty terminal at Fuse Holder.
 - B. The neutral conductor (N) should be connected to the empty terminal at location CB21.
 - C. The ground conductor (GND) should be connected to terminal CB GND2.
 - D. Tighten the cable gland and reinstall the control box cover.

CAUTION

DO NOT turn the power to the unit ON until the oil level in the reservoir is visible on the sightglass.

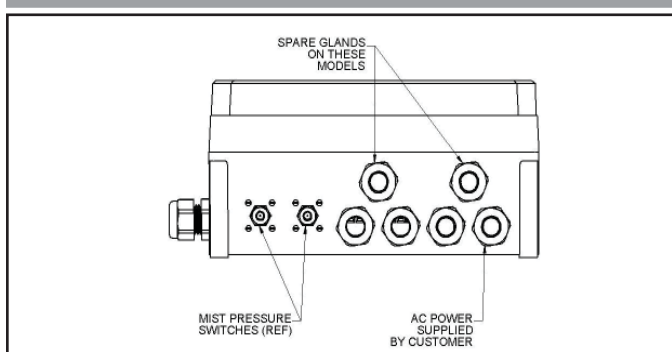

Figure 9 Power cable installation

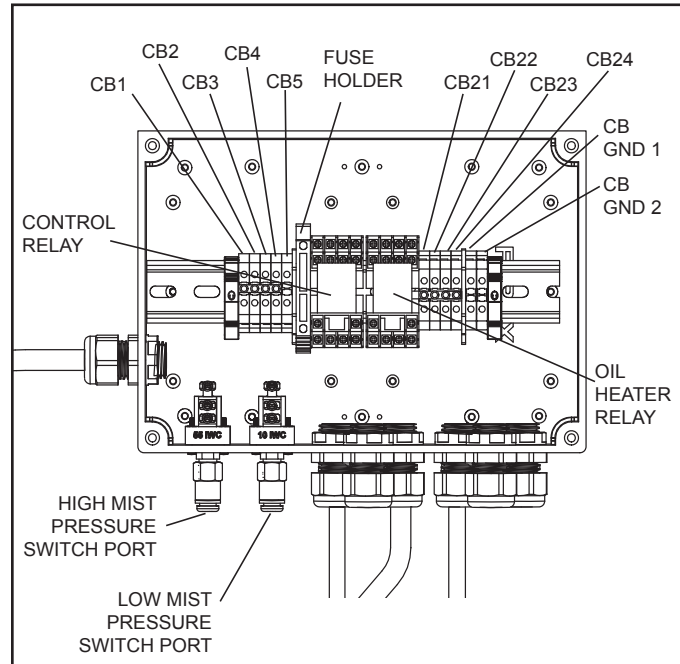

Figure 10 Control Box Terminal Locations

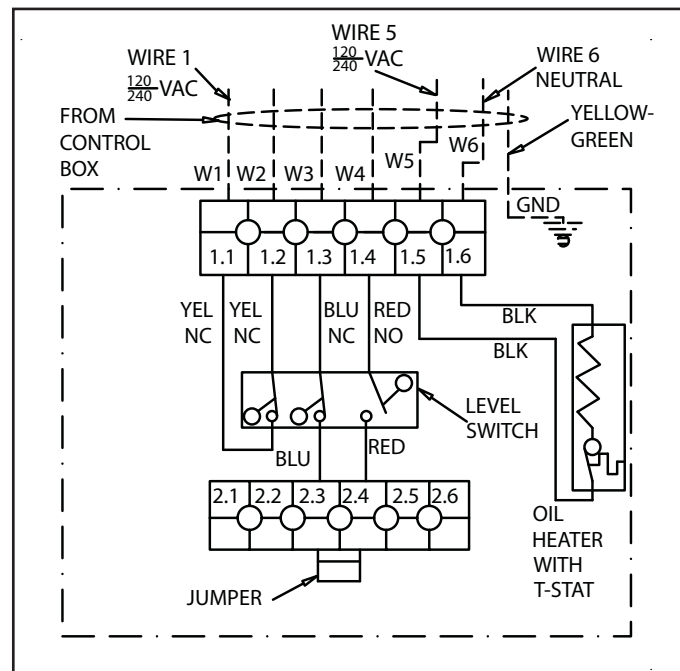

Figure 11 Wiring inside Mist Head (-C models)

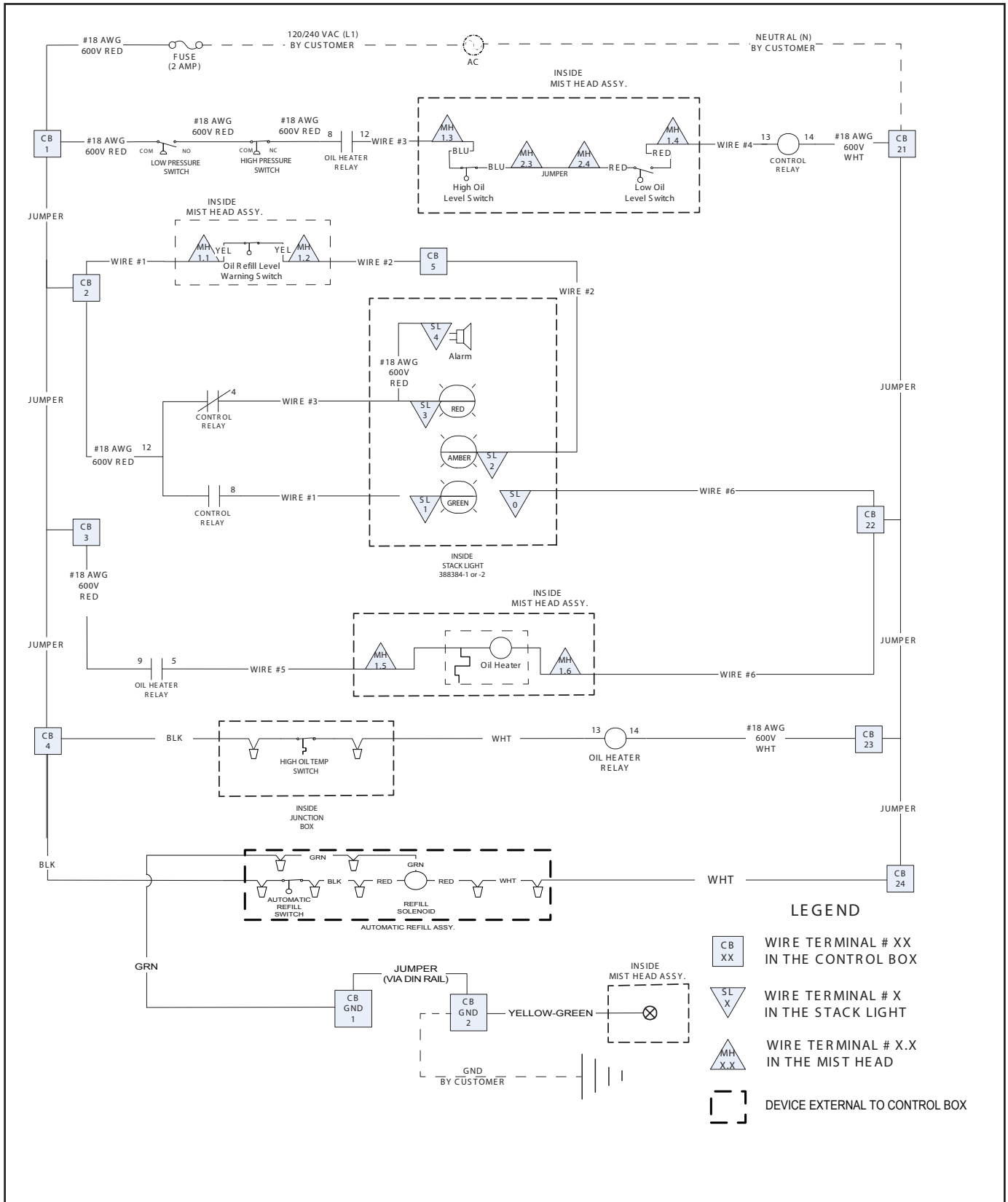

Figure 12 Wiring Diagram (-C models)

Operation

CAUTION

Do not operate unit without filling the reservoir with oil or damage may occur.

Mist Oil

Only oils branded as “mist oil” should be used. Use of other oils may result in no mist generation, poor mist quality, and/or lubrication failure. Many oil blends, including common motor oils, contain anti-foaming agents which will prevent successful mist generation.

All major lubricant suppliers market “mist oil” in a variety of viscosities and in both mineral & synthetic blends. They are specifically formulated to atomize easily and to maximize the reclassifying at the point of lubrication. Contact your local oil supplier or Alemite for recommendations.

Only very clean oil must be added to the reservoir. For this reason, this unit has been equipped with an automatic oil refill located on the oil reservoir cleanout door (see Figure 1).

Filling the Reservoir

In order to automatically fill the reservoir, the system should be connected to an oil refill pump system with a 1:1 pump ratio that provides 65 to 80 psi of oil inlet pressure. The pump must be connected the oil filter inlet port on the automatic refill assembly. A refill pump package 388415 is available for this purpose. Contact your Alemite vendor for details.

The oil reservoir can also be filled manually through the loader fitting located on the front face of the mist head (see Figure 1). It is designed to be used with an Alemite manual refill pump (P/N 388034) which includes 7 feet of hose, a 40-micron reusable filter element, and a loader coupler (mates with loader fitting). Contact your Alemite vendor for details.

While manually filling the reservoir, be mindful that the actual oil level may be higher than what is visible in the sight glass. When the level is about 2 gallons as indicated on the sight glass, stop filling and allow some time for the level in the sight glass to stop rising, then resume filling until the level in the sight glass is at (or just below) the 3-gallon mark.

CAUTION

Maintaining the air gap between the 3-gallon mark and the top of the tank is very important for the production of oil mist and the system's optimal operation. If the final oil level is above the 3-gallons mark, oil must be drained from the tank.

Adjusting Mist Pressure

1. Close the Air Regulator (18) by unscrewing the T-handle

until no tension is felt.

2. Open the air supply valve (not part of the Oil Mist Generator).
3. Turn the power ON. The red light on the Stack Light (31) should start flashing as no air should be flowing and the mist pressure is below the minimum value.
4. Adjust the air pressure regulator such that the Mist Pressure Gauge (28) shows 20" H₂O. If the system has been correctly sized and installed, the regulated air Pressure Gauge (17) should show between 25 and 40 psi depending on the generator capacity (CFM). The red light should turn off and the green light should turn on. If this is not the case, consult the trouble-shooting section.

Adjusting Oil Density

The mist head includes an Oil Adjustment Screw (7). This screw has been adjusted at the factory to provide optimum oil density without requiring further adjustments by the user. If the screw has been removed for cleaning or o-ring replacement, it should be re-installed to the factory setting, which is one revolution out (counter-clockwise) from the lightly seated position. Deviating from the factory setting should only be done after consultation with Alemite Technical Service.

System Alarms and Warning

Models in this Service Guide are equipped with a stack light with a sound module. The meanings of light/sound combinations are listed in the table below. Any other light/sound combination represents a stack light malfunction and the reader should refer to the trouble-shooting section.

Light/Sound Combinations	Meaning
Sound-OFF Red-OFF Amber-OFF Green-ON	System operating within acceptable range
Sound-OFF Red-OFF Amber-ON Green-ON	System operating within acceptable range but a reservoir refill is required within the next 24 hours of operation. <i>This is a warning and not an alarm.</i>
Sound-ON Red-ON Amber-OFF Green-OFF	Low/High mist pressure or High oil temperature
Sound-ON Red-ON Amber-ON Green-OFF	Suspect Low Oil level and refill immediately if required. Other conditions may also be producing the red light. <i>This is an alarm and not a warning.</i>

In order to function properly, the module stack starting at the base must be: green, amber, red, sound (see Figure 1).

Surveillance

Although oil mist generators are very dependable and have no moving parts to wear out, it should be noted that these units have no included signalling devices to alert the user of problems. “Reclassifier” fittings can be contaminated and clogged, regulated air pressure can be mis-adjusted, and contaminated oil in the reservoir can occur.

It is important that, on a daily basis, the mist pressure, oil level, and regulated air pressure be observed. Many users “mark” the gauges with the desired value to allow anyone to assure that they are set properly.

Since the oil mist lubrication “system” is essentially enclosed, the most convenient “tool” to assure good mist generation is the Safety Relief Valve (9) (located on the mist head). Pulling the ring on the Safety Relief Valve (9) can be used to temporarily open the Safety Relief Valve (9).

A large amount of mist (smoke) will be discharged in a properly operating generator. It should be “dry” and not spurting oil drops. When the Safety Relief Valve (9) is opened, the mist pressure will drop. Upon the release of the ring, the Safety Relief Valve (9) will close and the mist pressure will climb to the proper setting.

Maintenance



CAUTION

Shut off electrical power and air supply to the unit before performing maintenance on the unit.

Clean oil and clean compressed air are vital for long trouble free operation and are only achievable with proper maintenance. The following schedule of maintenance should be modified for adverse operating conditions such as excessive oil and/or air temperatures and poor air quality.

At least once a year, clean the interior Air Filter (19) (refer to Instruction Sheet SER 5604-2).

At least once a year, clean the Oil filter on oil refill pump.

At least once a year, clean the interior of Oil Reservoir as follows:

1. Drain oil from Reservoir by removing Pipe Plug (20) at bottom of the Reservoir. Properly dispose of drained oil.
2. Remove the Cleanout Door (24) and clean the interior of the Reservoir using a suitable solvent.
3. Re-install the Pipe Plug (20) and Cleanout Door (24) then refill reservoir following instructions under Operation section on page 10.

At least every six months clean the Nozzle (13), Inlet Screen (26), and Oil Adjusting Screw (7) as follows:

Before initiating removal of mist head ensure availability of replacement parts:

Gasket (4) (P/N 387299)

O-ring (14) (P/N 171018-44)

O-ring (11) (P/N X171018-12(10 pack))

Copper Gasket (12) (P/N 131266)

Above parts are available as Seal Kit 393806.

1. Disconnect Air Inlet Tube (15) from mist head.
2. Remove Cover (2) from mist head and cover from electrical junction box (behind mist head).
3. Disconnect cable (seven wires) from terminal strip and ground screw.
4. Loosen cable gland and pull cable out of mist head.
5. Remove four mist head Screws (4) and carefully lift mist head assembly out of the reservoir. Take care to prevent damage to Oil Heater (27) as head assembly is removed. Discard mist head O-ring (14).
6. Remove Nozzle (13). Discard Copper Gasket (12) and O-ring (11).
7. Remove Inlet Screen (26).
8. Loosen Setscrew (5) and remove Oil Adjustment Screw (7).
9. Clean the Nozzle (13) (oil inlet bore at top of nozzle and angled venturi holes just above nozzle threads as shown in figure 13), the Inlet Screen (26), the Oil Adjustment Screw (7), and its seat in the Mist Head using a suitable solvent.

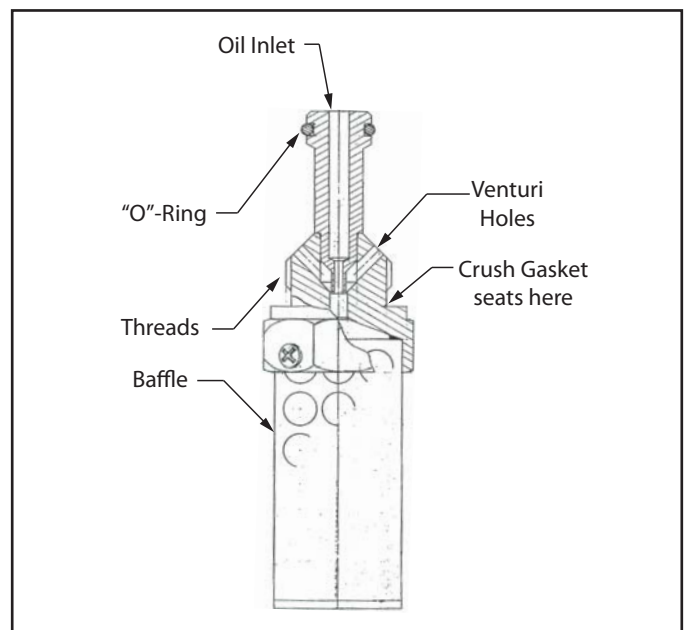

Figure 13 Mist Nozzle Assembly

10. Re-install the Nozzle **(13)** with new O-ring **(11)** (lubricate with oil before assembly) and Copper Gasket **(12)**. Take care to prevent damage to O-ring **(11)** as it is installed on the Nozzle **(13)** neck and as the Nozzle **(13)** is installed in the mist head.

The integrity of both “O”-ring **(11)** (which seals the vacuum to pull oil up the pick-up tube) and the Copper Gasket **(12)** (which seals regulated air pressure) is absolutely vital to successful mist generation. The Nozzle **(13)** must be tightened firmly to properly compress the Copper Gasket **(12)**. Failure to do so will prevent proper mist generation.

11. Re-install the Inlet Screen **(26)**. Do not use thread sealant.
12. Re-install Oil Adjustment Screw **(7)** with new O-ring **(6)** (lubricate with oil before assembly) by gently turning clockwise until it stops, then backing out one revolution. Tighten Setscrew **(5)** to lock Oil Adjustment Screw **(7)**
13. Before re-installing mist head assembly into reservoir bench-test as follows:
- Obtain a clean container and fill with mist oil to a sufficient level to completely cover the the oil Inlet Screen **(26)**.
 - Make a temporary air connection to the air inlet of the mist head.
 - Immerse the oil inlet tube into the container and make sure Inlet Screen **(26)** is completely submerged.
 - Apply air. Within a few seconds, a significant amount of mist should be generated through the holes in the baffle at the bottom of the Nozzle **(13)**. This will assure that the Nozzle **(13)** O-ring **(11)** is undamaged and the Copper Gasket **(12)** has been properly compressed.
14. Re-install mist head assembly with a new mist head O-ring **(14)** by reversing steps 1-5 and making sure all connections are tight.

Service

- Air Regulator 7604-1:
Refer to Instruction Sheet SER 7604-1
- Air Filter 5644-1:
Refer to Instruction Sheet SER 5604-2
- Stack Light 388384-1-2:
Replacement modules are available from:
C3 Controls
Beaver, PA
Tel: 724-775-7926
www.c3controls.com

Trouble-Shooting

Special Note:

There is a direct correlation between mist pressure and regulated air pressure. Increasing the regulated air pressure will increase the mist pressure. Mist pressure is measured in inches of water column (i.e., 20" H₂O), while regulated air pressure is measured in PSIG. Most “systems” are designed to operate successfully at 20" H₂O mist pressure. Operating at higher mist pressures will result in increased oil consumption.

Depending upon the system design and the number of “re-classifier” fittings installed, to achieve 20" H₂O will require a regulated air pressure of 20-45 psig. The key value is the mist pressure, not the regulated air pressure. The actual regulated air pressure to achieve 20" H₂O should be noted and recorded. High or Low mist pressure conditions will be based upon the mist pressure reading with the regulated air pressure unchanged from what was originally recorded.

<p>Changes Since Last Printing Initial release</p>
--

Condition	Probable Cause	Remedy
High Mist Pressure	<ol style="list-style-type: none"> 1. “reclassifier” fittings clogged or plugged 2. Oil condensate “trapped” in distribution piping 3. Regulated air supply has been mis-adjusted 	<ol style="list-style-type: none"> 1. Clean or replace “reclassifier fittings” 2. Remove “sags” 3. Correct to recorded value
Extremely High Mist Pressure (Relief valve opens)	<ol style="list-style-type: none"> 1. Failure of Crush Gasket (12) to seal Nozzle (13) to mist head 2. Severe or total blockage in distribution piping 	<ol style="list-style-type: none"> 1. Remove mist head assembly from reservoir and tighten/replace Copper Gasket (12) 2. Remove blockage
Fluctuating Mist Pressure	Oil condensate “trapped” in distribution piping	Remove “sags”
Low Mist Pressure	<ol style="list-style-type: none"> 1. Open line/valves or leaks in the distribution piping 2. Additional “reclassifiers” installed in system 3. Mist head passages plugged 4. Oil Inlet Screen (26) clogged 5. Air filter element clogged 6. Closed air supply line 	<ol style="list-style-type: none"> 1. Close valves or fix leaks 2. Adjust regulated air pressure to achieve 20” H₂O 3. Disassemble and clean 4. Dissassemble and clean 5. Replace 6. Open air supply line
Lubricated Component Temperature too high	<ol style="list-style-type: none"> 1. Distribution line obstruction 2. Incorrect Oil Adjustment Screw (7) setting 3. Reservoir overfilled 4. Foreign material in Inlet Screen (26) 5. Foreign material in distribution vent line(s) 6. Air pressure setting too low 7. Foreign material in “reclassifier” fitting(s) 8. Oil temperature too low 9. Improper oil or incompatible oils 10. Vacuum leaks <ol style="list-style-type: none"> a. Damaged Copper Gasket (12) and/or O-Ring (11) b. Damaged Oil Adjustment Screw O-Ring (6) c. Initial tightening of Oil Pickup Tube not sufficient 	<ol style="list-style-type: none"> 1. Remove low spots in distribution line 2. Set Oil Adjustment Screw (7) 3. Drain oil until the full mark is reached on the reservoir 4. Clean or replace Inlet Screen (26) 5. Clean distribution vent line(s) 6. Increase air pressure 7. Clean or replace “reclassifier” fitting(s) 8. Replace Oil Heater (27) 9. Check with supplier on oils specific for aerosol lubrication 10. <ol style="list-style-type: none"> a. Replace Copper Gasket (12) and/or O-Ring (11) b. Replace Oil Adjustment Screw O-Ring (6) c. Tighten Oil Pickup Tube into Head
Red light – No sound	<ol style="list-style-type: none"> 1. Disconnected sound module 2. Incorrect module arrangement 3. Defective module 	<ol style="list-style-type: none"> 1. Turn the sound module clockwise gently until it comes to a stop. 2. Ensure that starting at the base, the module arrangement is: green, amber and red with the sound module at the top. 3. Replace module.
Sound – No red light	<ol style="list-style-type: none"> 1. Disconnected red light module 2. Incorrect module arrangement 3. Defective module 	<ol style="list-style-type: none"> 1. Turn the red light module clockwise gently until it comes to a stop. 2. Ensure that starting at the base, the module arrangement is: green, amber and red with the sound module at the top 3. Replace module.
Sound – Light other than red	<ol style="list-style-type: none"> 1. Incorrect module arrangement 	<ol style="list-style-type: none"> 1. Ensure that starting at the base, the module arrangement is: green, amber and red with the sound module at the top.