

Improve uptime with the E-series upgrade

Discover the benefits of the SKF Cooper E-series with increased carrying capacity

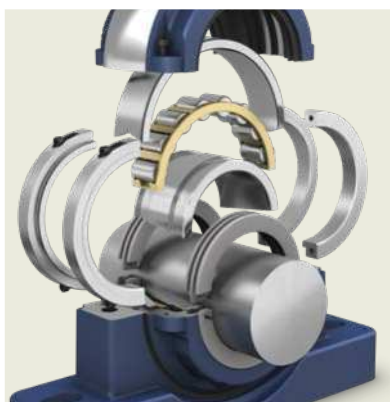
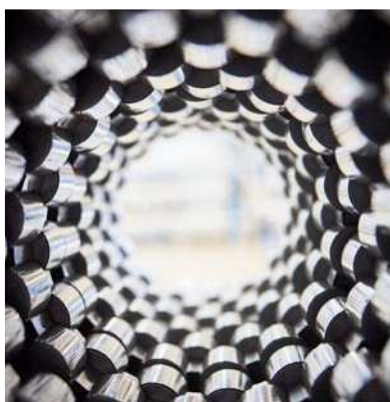

Making an excellent product even better

SKF Cooper roller split bearings are ideal for reducing machinery maintenance and repair downtime. The advantages of the SKF Cooper split bearing solution are especially valuable in tight, inaccessible or trapped locations, for example, between the head pulley and gearbox or motor, where the need to dismount associated equipment is eliminated.

The upgraded E-series includes an extended range of series O1 and O2 bearings in bore sizes up to 150 mm, complementing the entire product range with sizes up to 300 mm. You can replace existing O1 and O2 bearings with new bearings in the same dimensions. The upgrade includes a unique and patented brass cage design with an optimized roller complement, increasing the carrying capacity and the rating life. This contributes to improved service life and uptime.



Typical applications

- Belt and screw conveyors
- Industrial fans
- Propeller shafts
- Water turbines
- Industrial drive shafts

The patented cage design



How you benefit from the upgrade

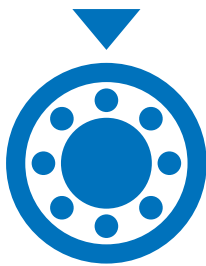

High carrying capacity

Unique and patented brass cage design



Longer L_{10} life and greater safety margins

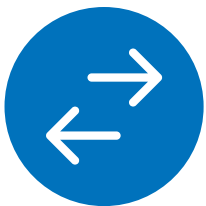

Fully interchangeable

Dimensionally interchangeable with corresponding 01 and 02 bearings



No changes needed to housing, cartridge or shaft

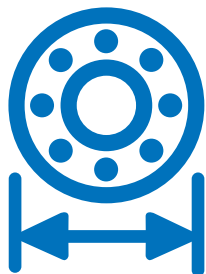

Wide product range

Product range up to 300 mm shafts



Works for a large number of applications

Split cylindrical roller bearings and cartridges

d 35 – 60 mm

1 3/16 – 2 1/4 in.

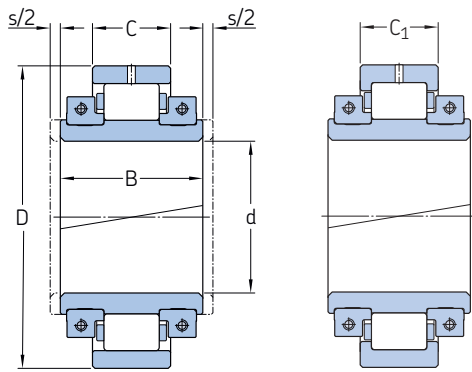

Non-locating

Locating

Shaft diameter and bearing/cartridge dimensions				Load ratings			Limiting speed	Designations ²⁾ Bearing	
d	D	B	C	C ₁	dynamic	static			axial
mm/in.	mm				C	C ₀	C _a	r/min	
					kN			–	
1 3/16	84.14	50.1	23.8	23.8	81	86	3.6	5 400	01EB103
1 1/4	84.14	50.1	23.8	23.8	81	86	3.6	5 400	01EB104
35	84.14	50.1	23.8	23.8	81	86	3.6	5 400	01EB35M
1 7/16	84.14	50.1	23.8	23.8	81	86	3.6	5 400	01EB107
1 1/2	84.14	50.1	23.8	23.8	81	86	3.6	5 400	01EB108
40	84.14	50.1	23.8	23.8	81	86	3.6	5 400	01EB40M
1 11/16	98.42	55.7	25.4	25.4	95	105	3.8	4 630	01EB111
1 3/4	98.42	55.7	25.4	25.4	95	105	3.8	4 630	01EB112
45	98.42	55.7	25.4	25.4	95	105	3.8	4 630	01EB45M
1 15/16	98.42 107.95	55.7 67.5	25.4 35	25.4 35	95 139	105 152	3.8 9.3	4 630 4 350	01EB115 02EB115
50	98.42 107.95	55.7 67.5	25.4 35	25.4 35	95 139	105 152	3.8 9.3	4 630 4 350	01EB50M 02EB50M
2	98.42 107.95	55.7 67.5	25.4 35	25.4 35	95 139	105 152	3.8 9.3	4 630 4 350	01EB200 02EB200
55	114.3	55.7	27	27	135	157	7.2	3 940	01EB55M
2 3/16	114.3 127	55.7 72.3	27 38.9	27 38.9	135 179	157 205	7.2 13.5	3 940 3 680	01EB203 02EB203
2 1/4	114.3 127	55.7 72.3	27 38.9	27 38.9	135 179	157 205	7.2 13.5	3 940 3 680	01EB204 02EB204
60	114.3 127	55.7 72.3	27 38.9	27 38.9	135 179	157 205	7.2 13.5	3 940 3 680	01EB60M 02EB60M

¹⁾ "s" is the total permissible axial displacement from one extreme position to the other. "s/2" is the permissible displacement from the central position.

²⁾ Only basic designations are shown. A suffix is required to specify if the bearing and cartridge are for the locating or non-locating position. Other bearing options and alternative seals are available on request.

Split cylindrical roller bearings and cartridges

d 65 – 80 mm
2 7/16 – 3 1/4 in.

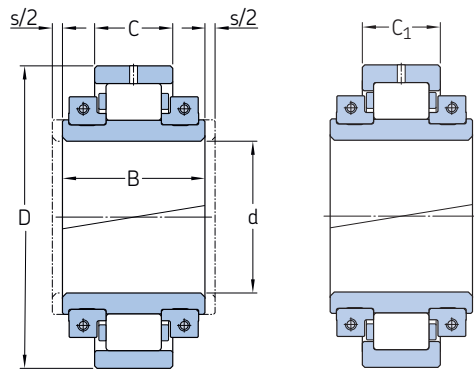

Non-locating

Locating

Shaft diameter and bearing/cartridge dimensions				Load ratings			Limiting speed	Designations ²⁾ Bearing	
d	D	B	C	C ₁	dynamic	static			axial
mm/in.	mm				C	C ₀	C _a	r/min	
2 7/16	114.3	55.7	27	27	135	157	7.2	3 940	01EB207 02EB207
	127	72.3	38.9	38.9	179	205	13.5	3 680	
2 1/2	114.3	55.7	27	27	135	157	7.2	3 940	01EB208 02EB208
	127	72.3	38.9	38.9	179	205	13.5	3 680	
65	114.3	55.7	27	27	135	157	7.2	3 940	01EB65M 02EB65M
	127	72.3	38.9	38.9	179	205	13.5	3 680	
2 11/16	133.35	61.2	31.8	31.8	166	197	10.8	3 310	01EB211 02EB211
	149.22	82.6	46.1	46.1	264	330	13.7	3 080	
2 3/4	133.35	61.2	31.8	31.8	166	197	10.8	3 310	01EB212 02EB212
	149.22	82.6	46.1	46.1	264	330	13.7	3 080	
70	133.35	61.2	31.8	31.8	166	197	10.8	3 310	01EB70M 02EB70M
	149.22	82.6	46.1	46.1	264	330	13.7	3 080	
2 15/16	114.3	48	27	27	91	128	7	4 125	100B215 01EB215 02EB215
	133.35	61.2	31.8	31.8	166	197	10.8	3 310	
	149.22	82.6	46.1	46.1	264	330	13.7	3 080	
75	133.35	61.2	31.8	31.8	166	197	10.8	3 310	01EB75M 02EB75M
	149.22	82.6	46.1	46.1	264	330	13.7	3 080	
3	133.35	61.2	31.8	31.8	166	197	10.8	3 310	01EB300 02EB300
	149.22	82.6	46.1	46.1	264	330	13.7	3 080	
80	152.4	70.7	38.9	38.9	234	299	13.6	2 790	01EB80M 02EB80M
	169.86	89.7	48.4	48.4	305	387	18.8	2 520	
3 3/16	152.4	70.7	38.9	38.9	234	299	13.6	2 790	01EB303 02EB303
	169.86	89.7	48.4	48.4	305	387	18.8	2 520	
3 1/4	152.4	70.7	38.9	38.9	234	299	13.6	2 790	01EB304 02EB304
	169.86	89.7	48.4	48.4	305	387	18.8	2 520	

¹⁾ "s" is the total permissible axial displacement from one extreme position to the other. "s/2" is the permissible displacement from the central position.

²⁾ Only basic designations are shown. A suffix is required to specify if the bearing and cartridge are for the locating or non-locating position. Other bearing options and alternative seals are available on request.

Split cylindrical roller bearings and cartridges

d 85 – 100 mm

3 7/16 – 4 in.

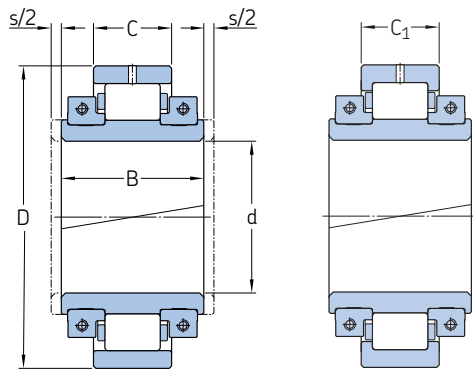

Non-locating

Locating

Shaft diameter and bearing/cartridge dimensions				Load ratings			axial	Limiting speed	Designations ²⁾ Bearing
d	D	B	C	C ₁	dynamic	static			
mm/in.	mm				C	C ₀	C _a	r/min	–
					kN				
85	152.4	70.7	38.9	38.9	234	299	13.6	2 790	01EB85M 02EB85M
	169.86	89.7	48.4	48.4	305	387	18.8	2 520	
3 7/16	152.4	70.7	38.9	38.9	234	299	13.6	2 790	01EB307 02EB307
	169.86	89.7	48.4	48.4	305	387	18.8	2 520	
3 1/2	152.4	70.7	38.9	38.9	234	299	13.6	2 790	01EB308 02EB308
	169.86	89.7	48.4	48.4	305	387	18.8	2 520	
90	152.4	70.7	38.9	38.9	234	299	13.6	2 790	01EB90M 02EB90M
	169.86	89.7	48.4	48.4	305	387	18.8	2 520	
3 11/16	174.62	81	45.3	45.3	320	421	19.6	2 340	01EB311 02EB311
	193.68	92.1	51.6	51.6	388	491	26.0	2 130	
95	174.62	81	45.3	45.3	320	421	19.6	2 340	01EB95M
	193.68	92.1	51.6	51.6	388	491	26.0	2 130	
3 3/4	174.62	81	45.3	45.3	320	421	19.6	2 340	01EB312 02EB312
	193.68	92.1	51.6	51.6	388	491	26.0	2 130	
100	174.62	81	45.3	45.3	320	421	19.6	2 340	01EB100M 02EB100M
	193.68	92.1	51.6	51.6	388	491	26.0	2 130	
3 15/16	152.4	65	38.9	38.9	191	288	18.3	3 090	100B315 01EB315 02EB315
	174.62	81	45.3	45.3	320	421	19.6	2 340	
	193.68	92.1	51.6	51.6	388	491	26.0	2 130	
4	174.62	81	45.3	45.3	320	421	19.6	2 340	01EB400 02EB400
	193.68	92.1	51.6	51.6	388	491	26.0	2 130	

¹⁾ "s" is the total permissible axial displacement from one extreme position to the other. "s/2" is the permissible displacement from the central position.

²⁾ Only basic designations are shown. A suffix is required to specify if the bearing and cartridge are for the locating or non-locating position. Other bearing options and alternative seals are available on request.

Split cylindrical roller bearings and cartridges

d 105 – 125 mm

4 3/16 – 4 1/2 in.

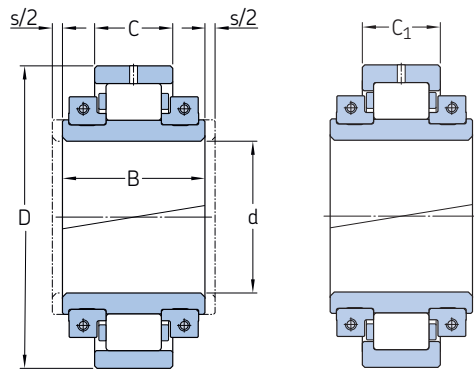

Non-locating

Locating

Shaft diameter and bearing/cartridge dimensions					Load ratings			Limiting speed	Designations ²⁾ Bearing
d	D	B	C	C ₁	dynamic	static	axial		
mm/in.	mm				C	C ₀	C _a	r/min	–
105	174.62	81	45.3	45.3	320	421	19.6	2 340	01EB105M 02EB105M
	193.68	92.1	51.6	51.6	388	491	26.0	2 130	
4 3/16	203.2	84.9	46.9	46.9	306	407	18.6	1 970	01B403 02B403
	228.6	100	57.2	57.2	454	583	31.2	1 820	
110	203.2	84.9	46.9	46.9	334	446	20.9	1 970	01EB110M 02EB110M
	228.6	100	57.2	57.2	498	628	43.6	1 820	
4 7/16	203.2	84.9	46.9	46.9	334	446	20.9	1 970	01EB407 02EB407
	228.6	100	57.2	57.2	498	628	43.6	1 820	
4 1/2	203.2	84.9	46.9	46.9	334	446	20.9	1 970	01EB408 02EB408
	228.6	100	57.2	57.2	498	628	43.6	1 820	
115	203.2	84.9	46.9	46.9	334	446	20.9	1 970	01EB115M 02EB115M
	228.6	100	57.2	57.2	498	628	43.6	1 820	
120	222.25	89.7	54	54	417	594	27.5	1 740	01EB120M 02EB120M
	254	114.3	63.5	63.5	613	794	56.8	1 600	
125	222.25	89.7	54	54	417	594	27.5	1 740	01EB125M 02EB125M
	254	114.3	63.5	63.5	613	794	56.8	1 600	

¹⁾ "s" is the total permissible axial displacement from one extreme position to the other. "s/2" is the permissible displacement from the central position.

²⁾ Only basic designations are shown. A suffix is required to specify if the bearing and cartridge are for the locating or non-locating position. Other bearing options and alternative seals are available on request.

Split cylindrical roller bearings and cartridges

d 130 – 145 mm

4 15/16 – 5 1/2 in.

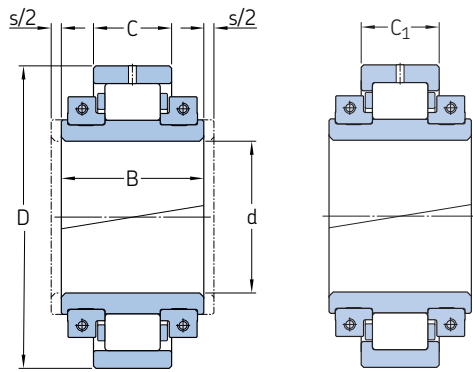

Non-locating

Locating

Shaft diameter and bearing/cartridge dimensions				Load ratings			Limiting speed	Designations ²⁾ Bearing	
d	D	B	C	C ₁	dynamic	static			axial
mm/in.	mm				C	C ₀	C _a	r/min	
					kN			–	
4 15/16	222.25	89.7	54	54	417	594	27.5	1740	01EB415 02EB415
	254	114.3	63.5	63.5	613	794	56.8	1600	
5	222.25	89.7	54	54	417	594	27.5	1740	01EB500 02EB500
	254	114.3	63.5	63.5	613	794	56.8	1600	
130	222.25	89.7	54	54	417	594	27.5	1740	01EB130M 02EB130M 03B130M
	254	114.3	63.5	63.5	613	794	56.8	1600	
	279.4	140	73.1	84.2	706	852	49	1500	
5 3/16	241.3	98.4	55.6	55.6	475	683	35.8	1570	01EB503 02EB503
	273.05	117.5	66.7	66.7	649	854	62.6	1450	
135	241.3	98.4	55.6	55.6	394	542	25.8	1570	01B135M
5 7/16	241.3	98.4	55.6	55.6	475	683	35.8	1570	01EB507 02EB507
	273.05	117.5	66.7	66.7	649	854	62.6	1450	
5 1/2	241.3	98.4	55.6	55.6	475	683	35.8	1570	01EB508 02EB508
	273.05	117.5	66.7	66.7	649	854	62.6	1450	
140	241.3	98.4	55.6	55.6	475	683	35.8	1570	01EB140M 02EB140M
	273.05	117.5	66.7	66.7	649	854	62.6	1450	
145	273.05	117.5	66.7	66.7	649	854	62.6	1450	02EB145M

¹⁾ "s" is the total permissible axial displacement from one extreme position to the other. "s/2" is the permissible displacement from the central position.

²⁾ Only basic designations are shown. A suffix is required to specify if the bearing and cartridge are for the locating or non-locating position. Other bearing options and alternative seals are available on request.

Split cylindrical roller bearings and cartridges

d 150 – 170 mm

5 15/16 – 6 1/2 in.

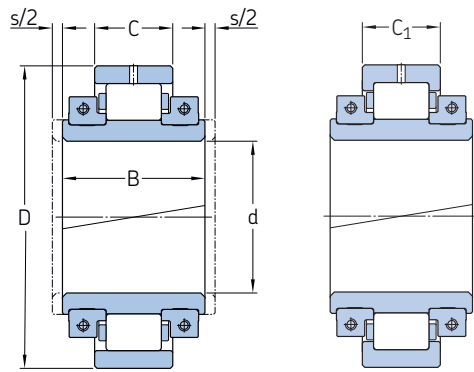

Non-locating

Locating

Shaft diameter and bearing/cartridge dimensions					Load ratings			Limiting speed	Designations ²⁾ Bearing
d	D	B	C	C ₁	dynamic	static	axial		
mm/in.	mm				C	C ₀	C _a	r/min	–
150	254	98.4	55.6	55.6	511	767	40.3	1450	01EB150M 02EB150M
	292.1	123.8	68.3	68.3	732	1 017	70.9	1320	
5 15/16	254	98.4	55.6	55.6	511	767	40.3	1450	01EB515 02EB515
	292.1	123.8	68.3	68.3	732	1 017	70.9	1320	
6	254	98.4	55.6	55.6	511	767	40.3	1450	01EB600 02EB600
	292.1	123.8	68.3	68.3	732	1 017	70.9	1320	
155	254	98.4	55.6	55.6	511	767	40.3	1450	01EB155M 02EB155M
	292.1	123.8	68.3	68.3	732	1 017	70.9	1320	
160	254	98.4	55.6	55.6	511	767	40.3	1450	01EB160M 02EB160M
	292.1	123.8	68.3	68.3	732	1 017	70.9	1320	

¹⁾ "s" is the total permissible axial displacement from one extreme position to the other. "s/2" is the permissible displacement from the central position.

²⁾ Only basic designations are shown. A suffix is required to specify if the bearing and cartridge are for the locating or non-locating position. Other bearing options and alternative seals are available on request.

skf.com | cooperbearings.com

® SKF and Cooper are registered trademarks of the SKF Group.

© SKF Group 2021

The contents of this publication are the copyright of the publisher and may not be reproduced (even extracts) unless prior written permission is granted. Every care has been taken to ensure the accuracy of the information contained in this publication but no liability can be accepted for any loss or damage whether direct, indirect or consequential arising out of the use of the information contained herein.

PUB BU/P2 19146 EN · May 2021

Certain image(s) used under license from Shutterstock.com.