

# PowerMaster air motor

Models 82730, 82736 and 82895

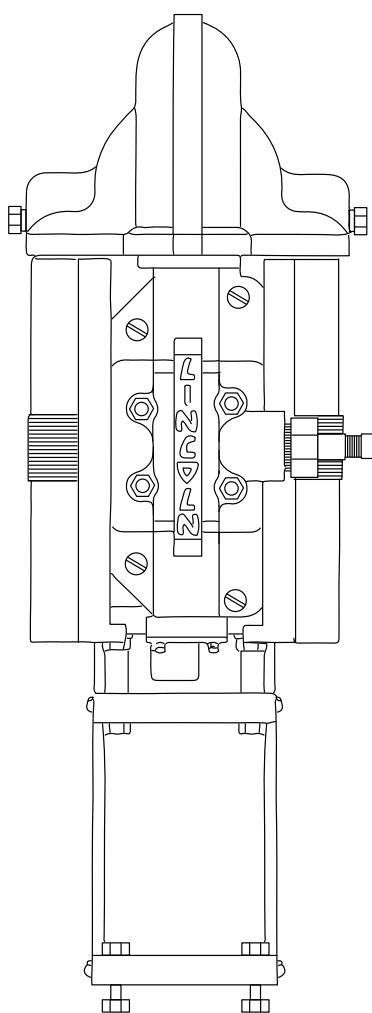
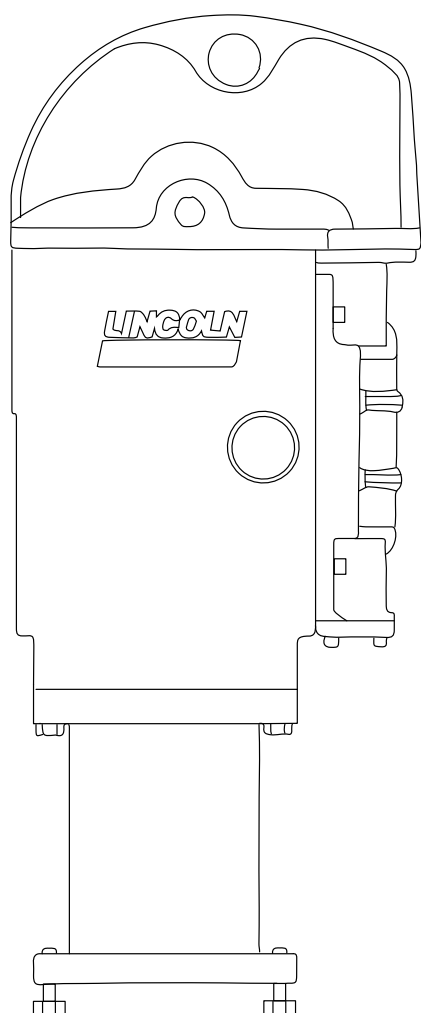

Date of issue	May 2023
Form number	402528
Version	4

# Contents

<b>Declaration of Incorporation*</b> . . . . .	<b>3</b>
<b>U.K. Declaration of Incorporation*</b> . . .	<b>4</b>
<b>Safety*</b> . . . . .	<b>5</b>
Explanation of signal words for safety . . . . .	5
Dimensions . . . . .	6
Valve actuator . . . . .	7
Power and pilot valves and air passage ports in valve plate . . . . .	7
<b>Attach air motor to pump tube</b> . . . . .	<b>8</b>
Service parts . . . . .	11
Parts codes . . . . .	12
Warranty . . . . .	16

\* Indicates change

	<b>Declaration of Incorporation*</b>	<b>DOCUMENT NUMBER</b> <b>402528.Dol</b>
<p style="text-align: center;"><b>Manufacturer name/address:</b>  <b>Lincoln Industrial Corporation</b>  5148 N. Hanley Road  St. Louis, MO 63134 U.S.A.  TEL: +1 (314) 679-4200 FAX: +1 (314) 679-4367</p> <p style="text-align: center;"><b>Authorized to compile the technical file:</b>  <b>SKF Lubrication Systems Germany GmbH</b>  Heinrich-Hertz-Straße 2-8  69190 Walldorf, Germany  TEL: +49 (0) 6227-330</p> <p style="text-align: center;">EMAIL: <a href="mailto:robert.collins@skf.com">robert.collins@skf.com</a> WEBSITE: <a href="http://www.skf.com">www.skf.com</a></p>		

This Declaration of Incorporation is issued under sole responsibility of the manufacturer. Lincoln Industrial Corporation hereby declares that the partly completed machinery stated below:

Name:  
PowerMaster air motors series II and III  
Model number(s): 82730, 82736, 82737  
Description: Reciprocating air motors to drive pumps  
Year of CE: 2023

in its intended use, is in conformity with the relevant union harmonization legislation:

Machinery Directive 2006/42/EC  
Noise Emission Directive 2000/14/EC

and conforms to the following harmonized standards:

EN ISO 4414: 2010  
Pneumatic fluid power – general rules and safety requirements for systems and their components

EN ISO 12100: 2010  
Safety of machinery. General principles for design. Risk assessment and risk reduction.

EN ISO 809:1998+A1:2009  
Pumps and pump units for liquids – common safety requirements

EN ISO 20361  
Liquid pumps and pumps units – noise test code grade 2 and 3 of accuracy

The following EHSR (Essential Health and Safety Requirements) have been applied:

1.1.2a – 1.1.2b – 1.1.2c – 1.1.3 – 1.1.5 – 1.2.2 – 1.2.4 – 1.2.5 – 1.3.2 – 1.3.3 – 1.3.5 – 1.3.7 – 1.3.8 – 1.5.3 – 1.5.6 – 1.7 – 1.7.1 – 1.7.1.1 – 1.7.3 – 1.7.4

The manufacturer maintains a technical file summary sheet containing test reports and product documentation:

Technical file summary sheet number:  
RA404192-0



*The partly completed machinery shown above should not be put into service until the final machinery into which it is to be incorporated has been declared in conformity with the provisions of the directive, where appropriate.*

I, the undersigned of Lincoln Industrial Corporation, do hereby declare that the equipment specified above, in its intended use, conforms to the requirements of the above EC Directive(s).



Robert Collins  
Technical Compliance Manager  
St. Louis, MO, U.S.A.  
2023/01/18

\* Indicates change

	<b>U.K. Declaration of Incorporation*</b>	<b>DOCUMENT NUMBER</b> <b>UK402528CA</b>
<p style="text-align: center;"><b>Manufacturer name/address:</b>  <b>Lincoln Industrial Corporation</b>  5148 N. Hanley Road  St. Louis, MO 63134 U.S.A.  TEL: +1 (314) 679-4200 FAX: +1 (314) 679-4367</p> <p style="text-align: center;"><b>Authorized to compile the technical file:</b>  <b>SKF (U.K.) Limited</b>  2 Canada Close  Banbury, Oxfordshire, OX16 2RT, GBR</p> <p style="text-align: center;">EMAIL: <a href="mailto:robert.collins@skf.com">robert.collins@skf.com</a> WEBSITE: <a href="http://www.skf.com">www.skf.com</a></p>		

This U.K. Declaration of Incorporation is issued under sole responsibility of the manufacturer. Lincoln Industrial Corporation hereby declares that the partly completed machinery stated below:

Name:  
PowerMaster air motors series II and III  
Model number(s): 82730, 82736, 82737  
Description:  
Reciprocating air motors to drive pumps  
Year of CE: 2023

in its intended use, is in conformity with the relevant union harmonization legislation:

Machinery Directive 2006/42/EC  
Noise Emission Directive 2000/14/EC

along with the following Directive(s) that were also applied with the above legislation:

- EN ISO 4414: 2010  
Pneumatic fluid power – general rules and safety requirements for systems and their components
- EN ISO 12100: 2010  
Safety of machinery. General principles for design. Risk assessment and risk reduction.
- EN ISO 809:1998+A1:2009  
Pumps and pump units for liquids – common safety requirements
- EN ISO 20361  
Liquid pumps and pumps units – noise test code grade 2 and 3 of accuracy

The following EHSR (Essential Health and Safety Requirements) have been applied:

- 1.1.2a – 1.1.2b – 1.1.2c – 1.1.3 – 1.1.5 – 1.2.2 – 1.2.4 – 1.2.5 – 1.3.2 – 1.3.3 – 1.3.5 – 1.3.7 – 1.3.8 – 1.5.3 – 1.5.6 – 1.7 – 1.7.1 – 1.7.1.1 – 1.7.3 – 1.7.4

The manufacturer maintains a technical file summary sheet containing test reports and product documentation:

Technical file summary sheet number:  
RA404192-0

*The partly completed machinery shown above should not be put into service until the final machinery into which it is to be incorporated has been declared in conformity with the provisions of the directive, where appropriate.*

I, the undersigned of Lincoln Industrial Corporation, hereby declare that the equipment specified above, in its intended use, conforms with the Essential Health and Safety Requirements of U.K. legislation Supply of Machinery (Safety) Regulations 2008 No. 1597 Annex I, Declaration of Incorporation by the time of placing it on the market.



Robert Collins  
Technical Compliance Manager  
St. Louis, MO, U.S.A.  
2022/04/05

\* Indicates change

# Safety\*

The assembly must be installed, maintained and repaired exclusively by persons familiar with the instructions.

Always disconnect power source (electricity, air or hydraulic) from the equipment when it is not being used.

This equipment generates high pressure. Extreme caution should be used when operating this equipment as material leaks from loose or ruptured components can inject fluid through the skin and into the body. If any fluid appears to penetrate the skin, seek attention from a doctor immediately. Do not treat injury as a simple cut. Tell attending doctor exactly what type of fluid was injected.

Any other use not in accordance with instructions will result in loss of claim for warranty or liability.

- Do not misuse, over-pressurize, modify parts, use incompatible chemicals, fluids, or use worn and/or damaged parts.
- Do not exceed the stated maximum working pressure of the equipment or of the lowest rated component in your system.
- Always read and follow the manufacturer's recommendations regarding fluid compatibility, and the use of protective clothing and equipment.
- Failure to comply may result in personal injury and/or damage to equipment.

## Explanation of signal words for safety

### NOTE

Emphasizes useful hints and recommendations as well as information to prevent property damage and ensure efficient trouble-free operation.

### CAUTION

Indicates a dangerous situation that can lead to light personal injury if precautionary measures are ignored.

### WARNING

Indicates a dangerous situation that could lead to death or serious injury if precautionary measures are ignored.

### DANGER

Indicates a dangerous situation that will lead to death or serious injury if precautionary measures are ignored.

### WARNING

Do not operate equipment without reading and fully understanding safety warnings and instructions.

Failure to follow warnings and instructions may result in serious injury.



### CAUTION

Do not operate equipment without wearing personal protective gear.

Wear eye protection. Protective equipment such as dust mask, non-skid safety shoes, hard hat, or hearing protection used for appropriate conditions will reduce personal injuries.

Failure to comply may result in light personal injury.



### WARNING



Do not allow any body part to be trapped by equipment. Body parts can be crushed by subassemblies during operation.

Failure to comply may result in death or serious physical injury.

### WARNING



Do not allow fluid to leak onto floor when operating equipment. If spill occurs, clean any fluid on floor before continuing operation.

Failure to comply may result in death or serious personal injury.

### WARNING

Do not use this equipment to supply, transport, or store hazardous substances and mixtures in accordance with annex I part 2-5 of the CLP regulation (EG 1272/2008) or HCS 29 CFR 1910.1200 marked with GHS01, GHS06 and GHS08 hazard pictograms shown:



\* Indicates change

Dimensions

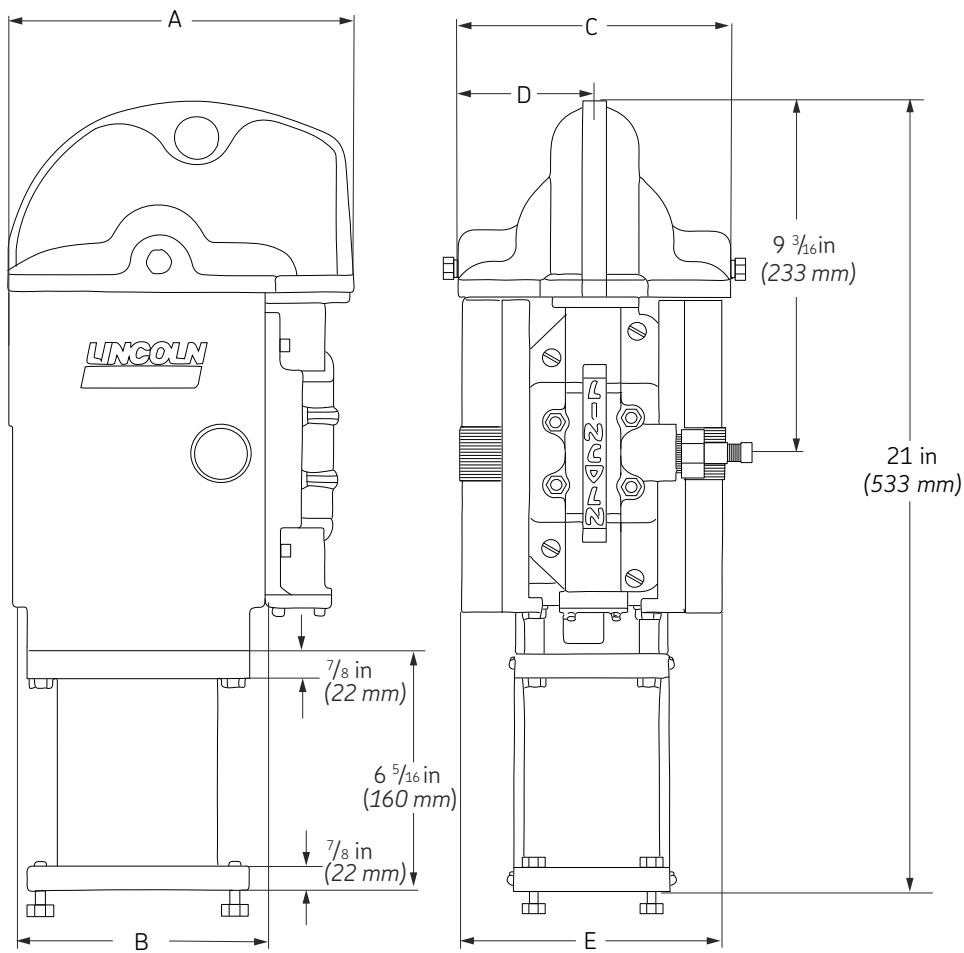
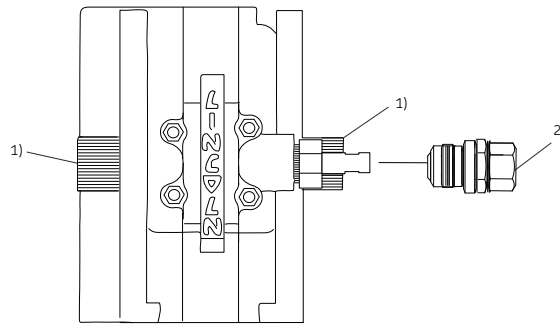

Model	A		B		C		D		E	
	in	mm	in	mm	in	mm	in	mm	in	mm
87230 and 82895	9	228	6 5/8	168	5 1/2	140	2 3/4	70	4 3/4	120
82736	10 7/8	296	8 3/8	213	7 1/2	191	3 3/4	95	6 5/8	168

1) 3/4 in NPTF exhaust  
 2) 1/2 in NPTF inlet for models 87230 and 82895. 3/4 in NPTF inlet for model 82736.

Fig. 2

Valve actuator

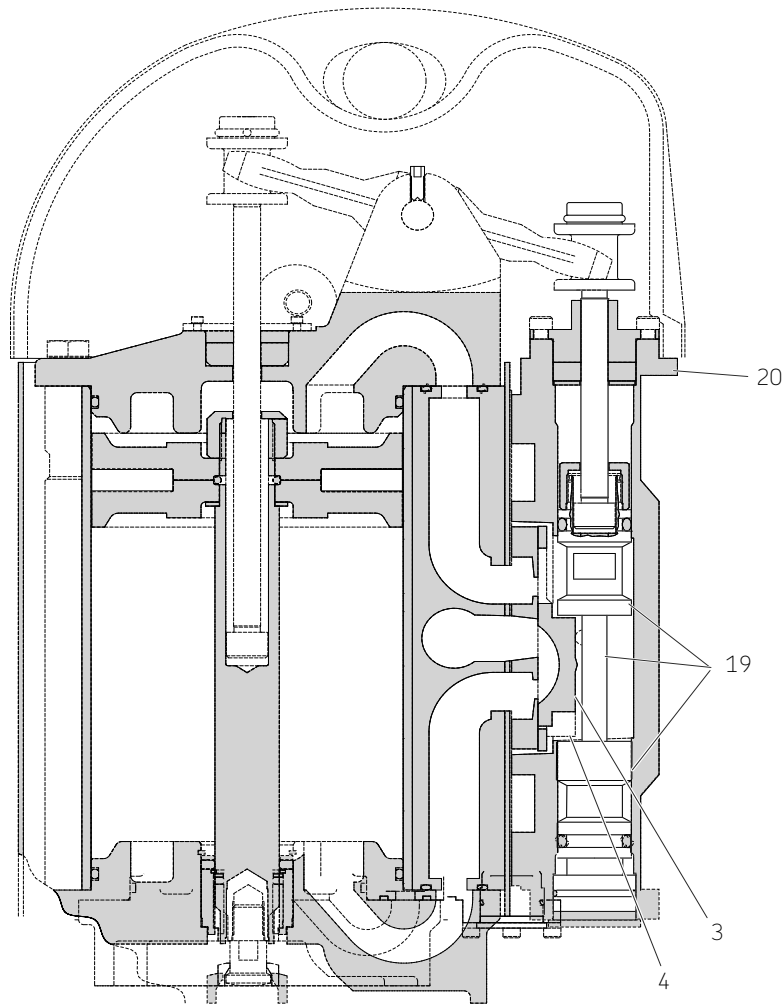

**NOTE**

When assembling air valve components, verify power slide valve, pilot slide valve and valve actuator (19) are in **down** position (→ Fig. 2). Valve actuator (19) should bridge slide valves without interference.

If acorn nuts (23) are tightened with valve parts misaligned, valve actuator (19) will be bent and valve body (20) will be ruined. Refer to Fig. 2.

Fig. 3

Power and pilot valves and air passage ports in valve plate

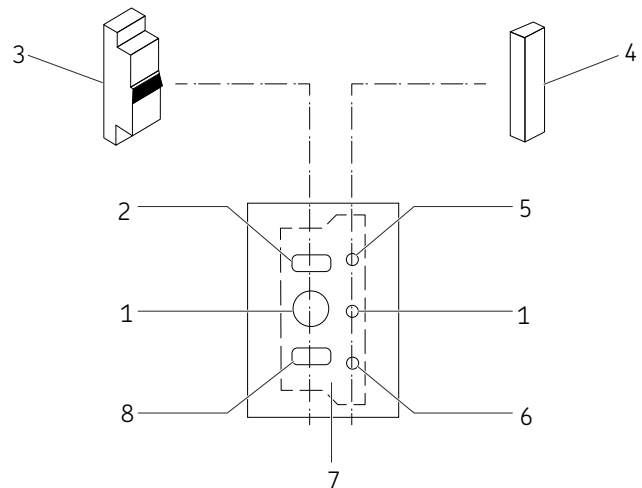

Item	Description
1	Exhaust port
2	Port to top of air cylinder
3	Power valve
4	Pilot valve
5	Port to top of valve actuator
6	Port to bottom of actuator
7	Valve plate
8	Port to bottom of air cylinder

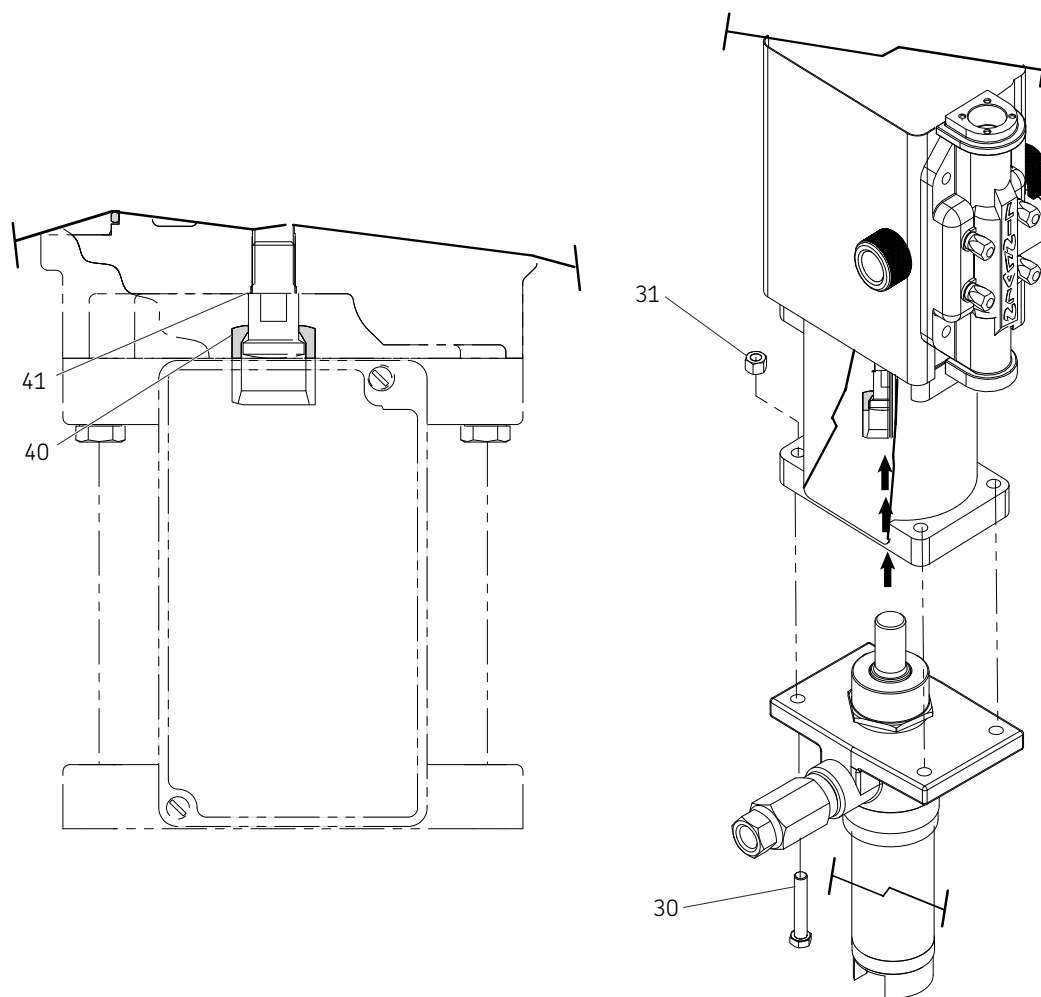

## Attach air motor to pump tube

Refer to **fig. IPB 2, page 10** for the following instructions:

- 1 Tightly connect air motor coupling nut (40) to pump plunger.
- 2 Attach air motor to pump outlet body (29) flange with four bolts (30) and nuts (31) (hand tight) supplied with air motor.
- 3 Slowly cycle pump several times, using just enough air pressure to operate pump without stalling
- 4 Stop pump on an up stroke and tighten four bolts (30) and nuts (31) to securely fasten air motor to pump tube.



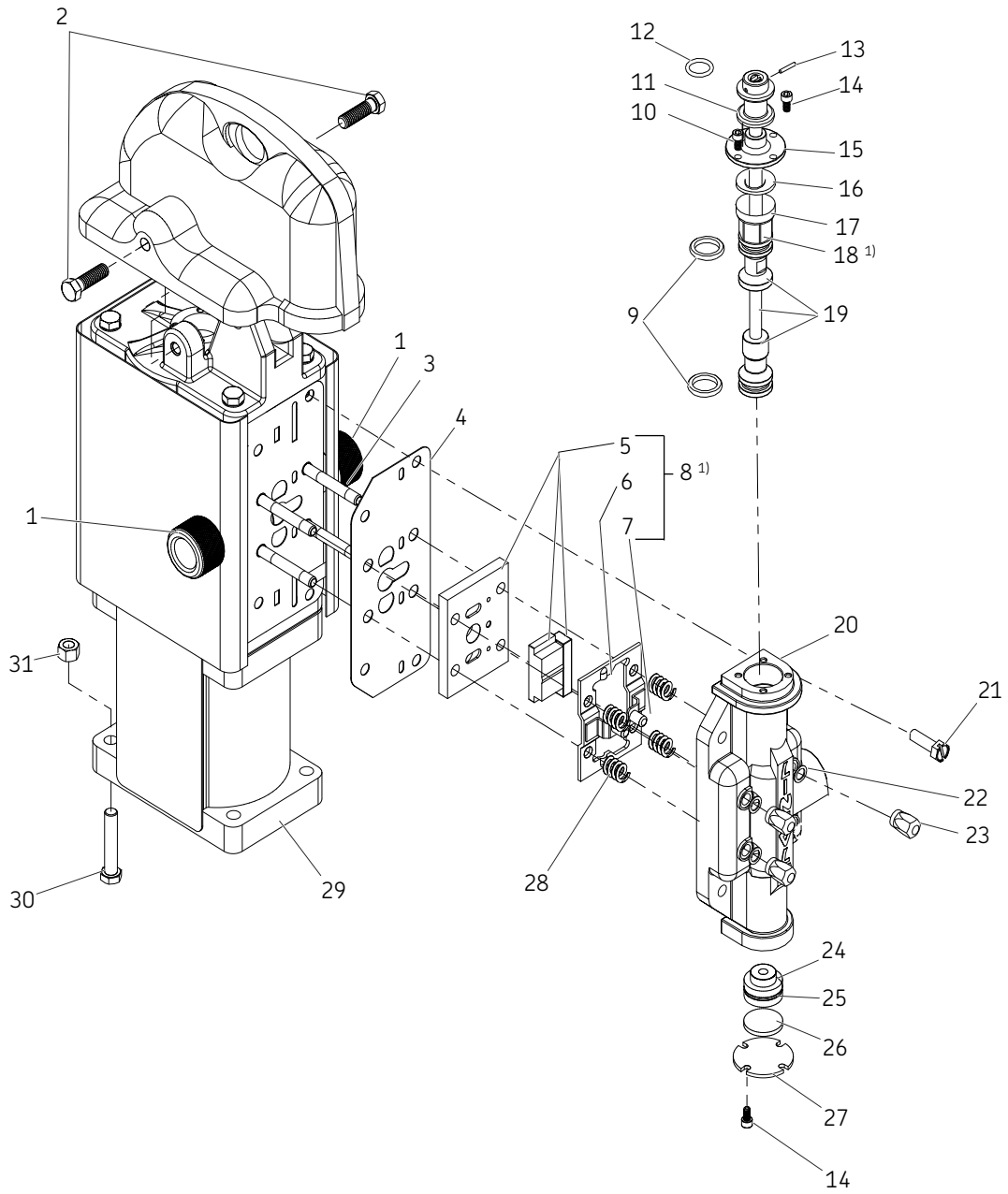

<sup>1)</sup> Refer to Fig. 3, page 7.

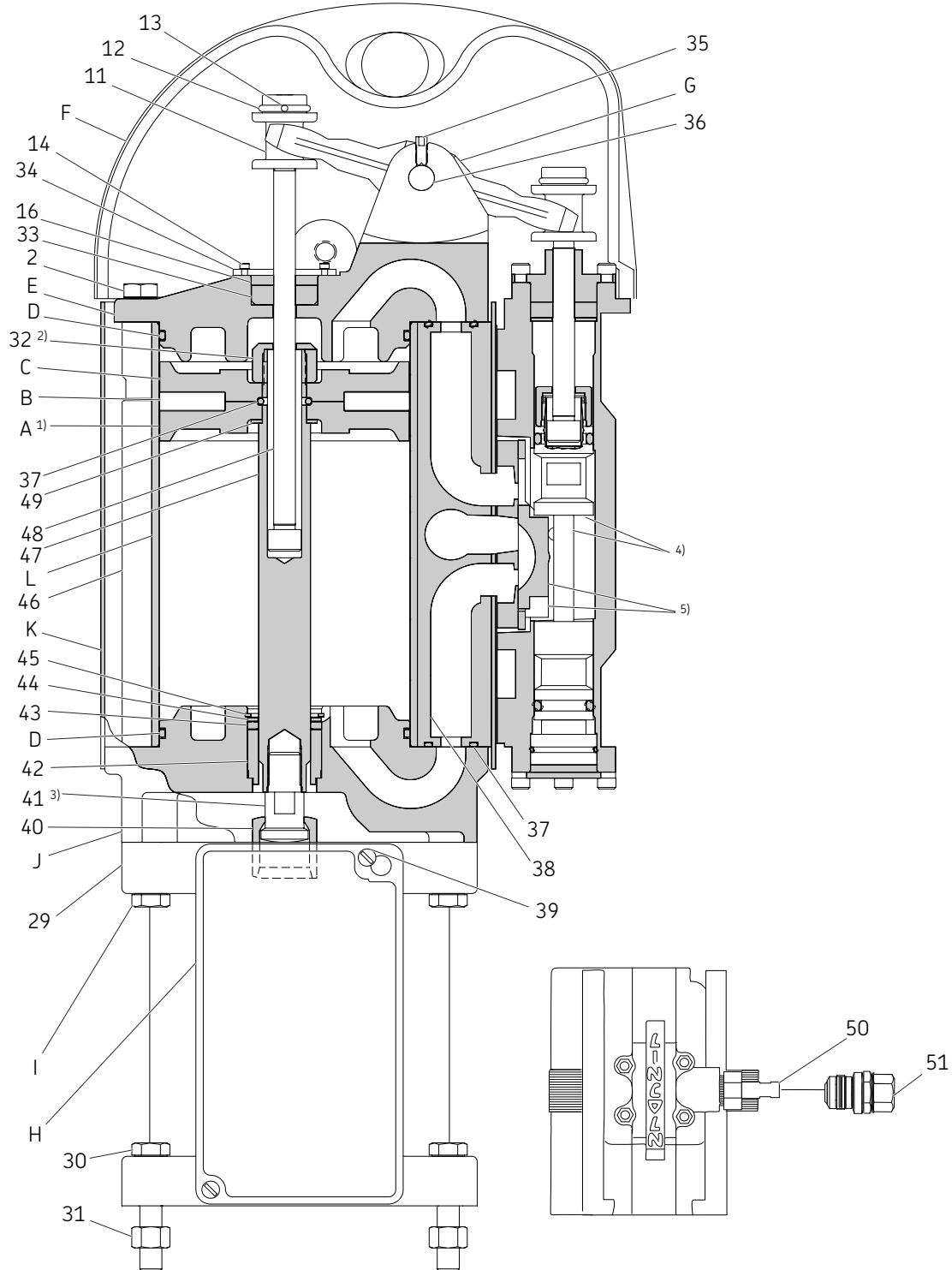

- 1) 6 in (152 mm) air motor has one piece piston. Refer to code letter C.
- 2) Torque to 50 to 55 ft.lb (68 to 75 Nm).
- 3) Torque to 65 to 70 ft.lb (88 to 94 Nm).
- 4) Valve actuator
- 5) Slide valves

**NOTE**  
Refer to **page 12** for **part codes**.

## Service parts

Item	Description	Part number	Quantity
1	Adapter	13526	2
2	Screw	50015	6 <sup>1)</sup>
3	Stud	13211	4
4	Valve gasket (nitrile)	38077 <sup>2) 3) 4)</sup>	1
5	Valves and seat	5)	1
6	Guide plate	5)	1
7	Catch	5)	2
8	Pneumatic actuator	83676	1
9	Packing (nitrile)	34298 <sup>2) 3) 4)</sup>	2
10	Trip rod guide	14363	1
11	Trip rod collar	13201	2
12	O-ring	247438	2
13	Pin	13213	2
14	Screw	50076	12
15	Trip rod	13204	1
16	Packing (nitrile)	34448 <sup>2) 3) 4)</sup>	2
17	Washer	48473	1
18	Trip rod stop	13210	1
19	Valve actuator	13942	1
20	Valve body	41230	1
21	Screw	50030	4
22	Gasket (fiber)	33079 <sup>2) 3) 4)</sup>	4
23	Acorn nut	13212	4
24	Spacer	16050	1
25	O-ring (waterborne acrylic resin)	34315	1
26	Packing (nitrile)	34297	1
27	Washer	48379	1
28	Valve spring seat	55261	4
29	Air motor support casting	40799	1
30	Bolt	50172	4
31	Nut	51087	4
32	Trip rod stop	13751	1
33	Trip rod guide	14364	1
34	Washer	48377	1
35	Screw	50730	2
36	Pin	13200	1
37	O-ring (nitrile)	34174 <sup>2) 3) 4)</sup>	3
38	Support	41229	1
39	Screw	50607	2
40	Coupling nut	15015	1
41	Coupling stud	11083	1
42	Spacer	13214	1
43	Packing (nitrile)	34299 <sup>2) 3) 4)</sup>	1
44	Washer	48216	1
45	Retaining ring	68881	1
46	Tie rod	13207	2
47	Piston rod	13752	1
48	Trip rod	13202	1
49	Washer	48265	1
50	Air nipple	653112	1
51	Air coupler (82730 and 82895)	655008	1
	Socket (82736)	655012	1

<sup>1)</sup> 10 required on 82739, 6 in (152 mm) air motor.

<sup>2)</sup> Model 82730 supplied in service kit 83035.

<sup>3)</sup> Model 82736 supplied in service kit 83036.

<sup>4)</sup> Model 82895 supplied in service kit 83037.

<sup>5)</sup> Available to order in valve guide plate assembly kit 83676 (8).

Parts codes (→ Fig. IPB 2, page 10)

Code	Description	82895 3 in (76 mm) Series "G"	82730 4 1/4 in (108 mm) Series "G"	82736 6 in (152 mm) Series "F"
A	Piston	40433	41228	N/A
B	D-packing (nitrile)	34321	34294	34503
C	Piston	40433	41228	40616
D	O-ring (nitrile)	34351 <sup>1)</sup>	34295 <sup>1) 2)</sup>	34455 <sup>3)</sup>
E	Upper cylinder head	40797	40782	40428
F	Cover	40426	40426	40429
G	Rocker arm	13203	13203	13218
H	Serial plate	244520	65239	65241
I	Screw	50124	50124	50123
J	Lower cylinder head	40796	40783	40524
K	Cover assembly	360313	360313	360320
L	Air cylinder	61603	61425	61435

<sup>1)</sup> Supplied in service kit 83037.

<sup>2)</sup> Supplied in service kit 83035.

<sup>3)</sup> Supplied in service kit 83036.

## Warranty

The instructions do not contain any information on the warranty. This can be found in the General Conditions of Sales, available at: [www.lincolnindustrial.com/technicalservice](http://www.lincolnindustrial.com/technicalservice) or [www.skf.com/lubrication](http://www.skf.com/lubrication).

[skf.com](http://skf.com) | [lincolnindustrial.com](http://lincolnindustrial.com)

® SKF, Lincoln and PowerMaster are registered trademarks of the SKF Group.

© SKF Group 2023  
The contents of this publication are the copyright of the publisher and may not be reproduced (even extracts) unless prior written permission is granted. Every care has been taken to ensure the accuracy of the information contained in this publication but no liability can be accepted for any loss or damage whether direct, indirect or consequential arising out of the use of the information contained herein.

May 2023 · Form 402528 Version 4