

TR/VT/P

The TR/VT/P seal combines the performance and characteristics of a rotary shaft seal with an axial shaft seal, enabling the use of just one seal rather than a rotary shaft seal and a separate axial shaft seal or V-ring.



The TR/VT/P seal is equipped with an additional dust lip, sufficiently robust to keep contamination out of the sealing system and prevent damaging the main lip.

These seals are mainly used for vertical rolls in hot profiled and billet mills, where the boundary dimensions of the rolls are to be very small and water, scale and other contaminants are to be considered.

The TR/VT/P seal fits into the space left to prevent leakage, extending the roll bearing life.

Due to the tough working conditions, these seals are made of the strongest, high-resistant rubber-fabric material to also prevent the seal from shrinking in its necessary open housing bore.

Although high-quality materials are used, it is strongly recommended to glue the TR/VT/P seal at the outer diameter in its housing.

Exclusive features of TR/VT/P seals are:

- Additional barrier against external contaminants due to additional dust lip
- Integration of axial seal in radial shaft seal → space saving design
- Possibility of assembly without retainer plate – requires gluing of the seal at the outer diameter
- Absence of external metallic parts and consequent prevention of damages to housing bore
- Protected spring to avoid slipping/popping out from groove

Possible size range for TR/VT/P seals: $\varnothing d_{\min} = 25 \text{ mm}$; $\varnothing D_{\max} = 2\,350 \text{ mm}$ (please also see the drawing at the next page)

Materials

The standard TR/VT/P seal is made of a nitrile elastomer (NBR) loaded with PTFE, in lip and body areas, but for particular applications and working conditions it can be produced in hydrogenated nitril elastomer (HNBR), silicone elastomer (VMQ) or fluorocarbon elastomer (FKM). Other combinations are available on request.

The table below shows working temperature ranges (minimum, maximum, peak (*)) applicable to each type of compound as well as possible spring configurations.

Material	Temperature		Standard spring	Special spring
	min	max		
	°C	°C (*)		
NBR	-30	+100 (+120)	Carbon steel	AISI 302
HNBR	-40	+150 (+175)	Carbon steel	AISI 302
VMQ	-50	+200 (+250)	Carbon steel	AISI 302
FKM	-20	+200 (+250)	AISI 302	AISI 316

Assembly of TR/VT/P seals

The drawing shows the details of the housing dimensions and the assembly of the TR/VT/P seal.

Particular applications or requirements different from those details shall be agreed with the TENUTE Technical Department / SKF Seals Application Engineering.

$$E_{\text{maximum}} = 0,5 \times F$$

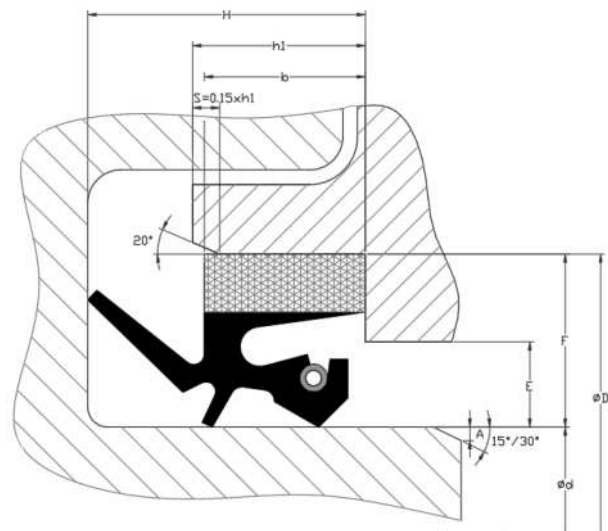

Shaft and housing diameter tolerance

Shaft diameter Ød		Tolerance	Housing diameter ØD		Tolerance
Over	Up to		Over	Up to	
mm	mm		mm	mm	
25	1 000	h11	45	1 000	H10
1 000	2 290	h10	1 000	2 350	H9

Housing height tolerance and chamfers

Housing height			Shaft chamfer			Housing chamfer
b	h1	Tolerance	Ød	Up to mm	A minimum	S
mm	mm	mm	Over mm		mm	
Up to 10	b + 0,3	+0,2 / 0	25	50	1,5	S = 0,15 x b
Over 10	b + 0,4	+0,3 / 0	50	250	3	
			250	800	4,5	
			800	1 500	6	
			1 500	2 290	7,5	

The housing height H can cover a tolerance between ±1,0 up to ±3,0 mm. The exact value needs to be agreed with the TENUTE Technical Department / SKF Seals Application Engineering.

Shaft and housing surface finishing

A roughness of Ra from 0,2 to 0,6 μm is recommended for the shaft in standard applications, while in case of high speeds, a finishing to Ra from 0,2 to 0,4 μm is recommended. Plunge grinding is required. For the housing bore a finish turning is sufficient.

Shaft hardness

Up to 15 m/s	Over 15 m/s
40 HRC	50 HRC and above

We recommend a gas nitriding heat-treating process with the minimal hardness shown in the table above. Higher shaft hardness (60 HRC) is recommended to increase the service-life of the shaft.

skf.com | skf.com/seals

® SKF and TENUITE are registered trademarks of the SKF Group
© SKF Group 2024

The contents of this publication are the copyright of the publisher and may not be reproduced (even extracts) unless prior written permission is granted. Every care has been taken to ensure the accuracy of the information contained in this publication, but no liability can be accepted for any loss or damage whether direct, indirect, or consequential arising out of the use of the information contained herein. All data mentioned in this publication are given as an indication. SKF Seals Application Engineering / TENUITE Technical Department reserves the right to change and improve its products according to application specifications and test results.

Seal data sheet TR/VT/P · April 2024