

K19-X

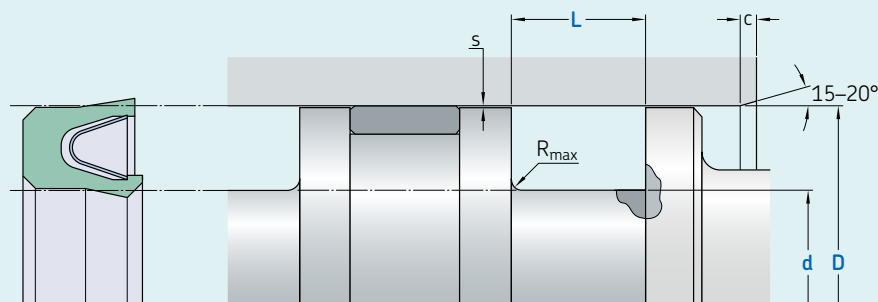

Ordering dimensions in blue

Surface roughness R_{tmax}	R_a
μm	

Sliding surface ≤ 2 $0.05-0.2$

Bottom of groove ≤ 6.3 ≤ 1.6

Groove face ≤ 15 ≤ 3

Bearing area: 50–95% and a cutting depth of $0.5 R_z$ based on $C_{ref} = 0\%$

Standard dimensions						Maximal radial extrusion gap				
D	d	L	R_{max}	c	s ¹⁾					
H9	h10	+ 0.2				20 bar	100 bar	200 bar	300 bar	400 bar
over	incl.									
mm						mm				
26 ²⁾	50	D – 6.2	4.8	0.3	1.55	0.35	0.17	0.12	0.10	0.08
50	120	D – 9.4	7.1	0.3	2.35	0.45	0.22	0.17	0.12	0.10
120	630	D – 12.2	9.5	0.3	3.05	0.60	0.31	0.25	0.15	0.12
630	1600	D – 19.0	15.0	0.3	4.75	0.87	0.48	0.38	0.28	0.20

¹⁾ Extrusion gap values shown above are valid for a temperature of 80 °C, higher temperatures require lower values.
²⁾ Smaller diameter available on request.

Ordering example

Profile
 D x d x L [mm]
 Sealing material / Spring

Piston seal K19-X
 100 x 90.6 x 7.1
 SKF Ecoflon 3 / 1.4310

Operating parameters

Material Seal	Spring	Temperature		Speed ¹⁾	Pressure ²⁾
		from	to	max	max
		°C		m/s	bar (MPa)
SKF Ecoflon 1	1.4310	-200	+260	15	200 (20)
SKF Ecoflon 1	2.4711	-200	+260	15	200 (20)
SKF Ecoflon 2	1.4310	-200	+260	15	400 (40)
SKF Ecoflon 2	2.4711	-200	+260	15	400 (40)
SKF Ecoflon 3	1.4310	-200	+260	15	400 (40)
SKF Ecoflon 3	2.4711	-200	+260	15	400 (40)
SKF Ecoflon 4	1.4310	-200	+260	15	400 (40)
SKF Ecoflon 4	2.4711	-200	+260	15	400 (40)
SKF Ecowear 1000	1.4310	-200	+90	15	200 (20)
SKF Ecowear 1000	2.4711	-200	+90	15	200 (20)

IMPORTANT NOTE: The stated operating conditions represent general indications. It is recommended not to use all maximum values simultaneously.

¹⁾ Surface speed limit values are valid only in the presence of a lubrication film.

²⁾ Pressure ratings depend on the size of the extrusion gap.

