

## TR/3/M/CS

The TR/3/M/CS seal is a rotary shaft seal based on the TR/3 design featuring a flexible metal band in the seal back as well as a circumferential groove and radial ports for lubrication.



It can be installed without a retainer plate. However, in extreme cases, a retainer plate might be advisable.

The TR/3/M/CS design provides good lip flexibility and elasticity, no shrinkage and remarkable advantages compared to normal rotary shaft seals with stiff metal insert or outside metal case.

This type of seal is used in sealing arrangements requiring two opposed seals due to aggressive environment, such as roll necks in hot and cold rolling mills.

Dimensions and tolerances are according to DIN 3760.

Maximum pressure capability is 0,5 bar.

Exclusive features of TR/3/M/CS seals are:

- Possibility of lubrication through the seal
- Possibility of assembly without retainer plate
- Improved resistance to possible shaft misalignments
- Decreased radial force exerted on shaft
- Reduced friction and consequent temperature decrease
- Protected spring to avoid slipping/popping out from groove
- Reduced spring preload
- Absence of external metallic parts and consequent prevention of damages to housing bore

Possible size range for TR/3/M/CS seals:  $\varnothing_{d_{min}} = 60 \text{ mm}$ ;  $\varnothing_{D_{max}} = 2\,350 \text{ mm}$  (please also see the drawing at the next page)

## Materials

The table below shows working temperature ranges (minimum, maximum, peak (\*)) applicable to each type of compound as well as possible spring configurations.

Material	Temperature		Standard spring	Special spring	Recommended circumferential shaft speed	Misalignment
	min	max				
	°C	°C (*)			m/s	
<b>NBR</b>	-30	+100 (+120)	Carbon steel	AISI 302	15	According to cross section
<b>HNBR</b>	-40	+150 (+175)	Carbon steel	AISI 302	20	
<b>FKM</b>	-20	+200 (+250)	AISI 302	AISI 316	25	

## Assembly of TR/3/M/CS seals

The drawing shows the details of the housing dimensions and the assembly of the TR/3/M/CS seal in applications without pressure.

Particular applications or requirements different from those details shall be agreed with the TENUTE Technical Department / SKF Seals Application Engineering.

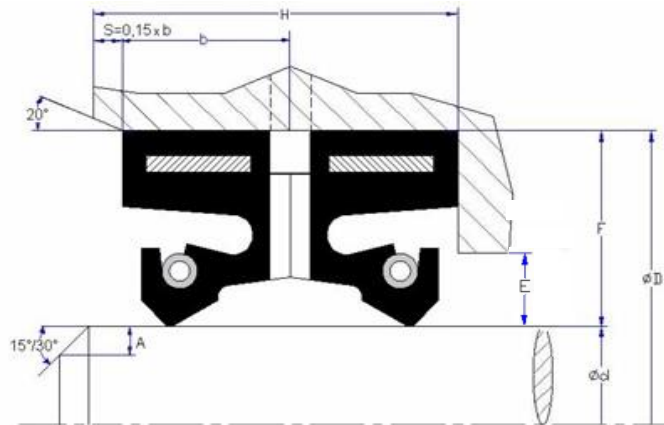

$$E_{\text{maximum}} = 0,5 \times F$$

## Shaft and housing diameter tolerance

Shaft diameter Ød		Tolerance	Housing diameter ØD		Tolerance
Over	Up to		Over	Up to	
mm	mm		mm	mm	
60	1 000	h11	80	1 600	H8
1 000	2 290	h10	1 600	2 350	+0,2 / 0

## Housing height tolerance and chamfers

Housing height			Shaft chamfer			Housing chamfer
b	H	Tolerance	Ød	A minimum		S
mm	mm	mm	Over mm	Up to mm	mm	
Up to 10	$2 \times b + 0,3$	+0,2 / 0	60	250	3	S = 0,15 x b
Over 10	$2 \times b + 0,4$	+0,3 / 0	250	800	4,5	
			800	1 500	6	
			1 500	2 290	7,5	

## Shaft and housing surface finishing

A roughness of Ra from 0,2 to 0,6  $\mu\text{m}$  is recommended for the shaft in standard applications, while in case of high speeds, a finishing to Ra from 0,2 to 0,4  $\mu\text{m}$  is recommended. Plunge grinding is required. For the housing bore a finish turning is sufficient.

## Shaft hardness

Up to 15 m/s	Over 15 m/s
40 HRC	50 HRC and above

[skf.com](https://skf.com) | [skf.com/seals](https://skf.com/seals)

® SKF and TENUTE are registered trademarks of the SKF Group  
© SKF Group 2024

The contents of this publication are the copyright of the publisher and may not be reproduced (even extracts) unless prior written permission is granted. Every care has been taken to ensure the accuracy of the information contained in this publication, but no liability can be accepted for any loss or damage whether direct, indirect, or consequential arising out of the use of the information contained herein. All data mentioned in this publication are given as an indication. SKF Seals Application Engineering / TENUTE Technical Department reserves the right to change and improve its products according to application specifications and test results.