

TR/7

The TR/7 seal is a rotary shaft seal developed to cope with pressures up to 5 bar at about 4 m/s circumferential speed without any shaft misalignment.



The special design allows lightening the radial lip force under pressure and consequently reduce friction.

The TR/7 requires a retainer plate for a correct operation.

The standard TR/7 seal back is made of high resistance cotton fabric combined with a nitrile elastomer (NBR) loaded with PTFE, in lip and body areas.

Exclusive features of TR/7 seals are:

- Reduction of radial lip force under pressure
- Reduced friction and consequent temperature decrease
- Absence of external metallic parts and consequent prevention of damages to housing bore
- No metal case and consequently no scratching of housing bore

Possible size range for TR/7 seals: $\varnothing d_{\min} = 25 \text{ mm}$; $\varnothing D_{\max} = 2\,480 \text{ mm}$ (please also see the drawing at the next page).

The TR/7 is also available as split version (TR/7/SPLIT) enabling easier assembly in applications, where it would be difficult or even impossible to use an endless design. Both solutions, TR/7 endless and TR/7/SPLIT, require a retainer plate for a correct operation. There is also the possibility of gluing the TR/7/SPLIT large diameter seals, preferably using cold gluing processes with a special template that is available on request.

The chart at the right-hand side shows the pressure over circumferential shaft speed valid for NBR elastomer.

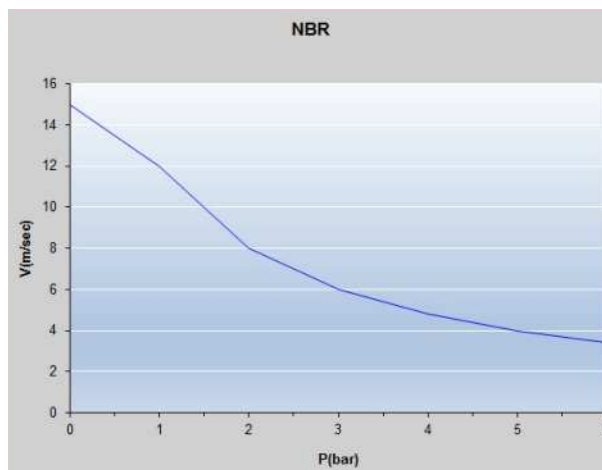

Materials

The TR/7 standard material is NBR (nitril rubber) loaded with PTFE, but for particular working conditions seals can be produced also in HNBR (hydrogenated nitril rubber), VMQ (silicone rubber) and FKM (fluorocarbon rubber) materials. Other combinations are available upon request.

The table below shows working temperature ranges (minimum, maximum, peak (*)) applicable to each type of compound.

Material	Temperature		Standard spring
	min	max	
	°C	°C (*)	
NBR	-30	+100 (+120)	Carbon steel
HNBR	-40	+150 (+175)	Carbon steel
VMQ	-50	+200 (+250)	Carbon steel
FKM	-20	+200 (+250)	AISI 302

Assembly of TR/7 seals

The drawing shows the details of the housing dimensions and the assembly of the TR/7 seal.

Particular applications or requirements different from those details shall be agreed with the TENUTE Technical Department / SKF Seals Application Engineering.

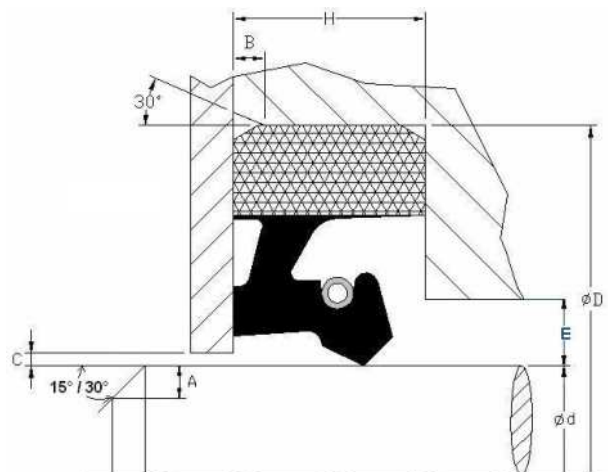

C_{maximum} ... see table below

$E_{\text{maximum}} = 0,5 \times F$

Clearance

Shaft diameter $\varnothing d$		Clearance C
Over	Up to	max
mm	mm	mm
25	600	1
600	2 420	1,5

Shaft and housing diameter tolerance

Shaft diameter $\varnothing d$		Tolerance	Housing diameter $\varnothing D$		Tolerance
Over	Up to		Over	Up to	
mm	mm		mm	mm	
25	1 000	h11	45	1 000	H10
1 000	2 420	h10	1 000	2 480	H9

Housing height tolerance

Housing height H	Tolerance
mm	mm
Up to 15	+0 / -0,1
Over 15	+0,1 / -0,1

Shaft and housing chamfers

Shaft diameter Ød		Shaft chamfer A	Housing diameter ØD		Housing chamfers	
Over	Up to	minimum	Over	Up to	H	B
mm	mm	mm	mm	mm	mm	mm
25	50	1,5	45	50	10	1
50	250	3	50	250	15	1,5
250	800	4,5	250	800	20	2
800	1 500	6	800	1 500	30	3
1 500	2 420	7,5	1 500	2 480	40	4

Shaft and housing surface finishing

A roughness of Ra from 0,2 to 0,6 µm is recommended for the shaft in standard applications, while in case of high speeds, a finishing to Ra from 0,2 to 0,4 µm is recommended. Plunge grinding is required. For the housing bore a finish turning is sufficient.

Shaft hardness

Up to 15 m/s	Over 15 m/s
40 HRC	50 HRC and above

skf.com | skf.com/seals

® SKF and TENUITE are registered trademarks of the SKF Group

© SKF Group 2024

The contents of this publication are the copyright of the publisher and may not be reproduced (even extracts) unless prior written permission is granted. Every care has been taken to ensure the accuracy of the information contained in this publication, but no liability can be accepted for any loss or damage whether direct, indirect, or consequential arising out of the use of the information contained herein. All data mentioned in this publication are given as an indication. SKF Seals Application Engineering / TENUITE Technical Department reserves the right to change and improve its products according to application specifications and test results.