

Weatherly Index / Índice Weatherly / Index Weatherly 310

2022
457285

Universal Joints

Crucetas
Joints de cardan

Passenger car, light, medium and heavy duty truck applications.
Includes Universal Joint dimensions & related parts

Aplicaciones de automóviles de pasajeros, camiones de uso ligeros, medianos y pesados.
Incluye las dimensiones de la Cruceta y las partes relacionadas

Applications pour voitures de tourisme et camionnettes légères, moyennes et véhicules lourds.
Comprend les dimensions des joints de cardan et des pièces connexes



Table of contents

Introduction

Universal joint identification.....	2A
How to use this catalog.....	3A
Manufacturer index.....	4A

Applications

RWD passenger car applications	1
2WD & 4WD light and medium duty truck applications.....	78
Heavy Duty.....	573

Universal Joint Related Parts

Double cardan CV parts	559
U-joint kit hardware listing	561

Universal Joint Dimensions

U-bolt dimensions	563
U-joints with 4 grooved round bearings.....	564
U-joints with 4 plain round bearings	567
U-joints with 2 grooved & 2 plain round bearings.....	571
Driveshaft Flexible Couplers	572
U-joints with 4 welded plate type round bearings.....	578
U-joints with 2 welded plate type & 2 plain round bearings.....	578
U-joints with 4 wing bearings.....	579
U-joints with 2 wing bearings & 2 grooved round bearings.....	582
U-joints with 2 wing bearings & 2 plain round bearings or 2 welded plate round bearings	583

Universal Joint identification

Round Inside Lock-Up/Snap Ring (ISR)

This universal joint design uses round bearing cups with a snap ring groove on the outside diameter of the bearings and machined flat surfaces on the inside of the yoke ears. It is easier to measure the lock-up for this style by measuring the yoke from inside ear to inside ear. If the yoke is not available, lock-up can be measured on the universal joint itself.

1. Assemble bearing cups onto cross.
2. Install snap rings in bearing grooves.
3. Remove rubber seals or clamp bearing cups with a C-clamp or vise.
4. Measure across the outside of the two installed snap rings facing one another to obtain the lock-up dimension.
5. Measure the outside diameters of the bearing cups. Conversion joints and some OE applications may have two different diameter bearing cups.
6. For conversion type universal joints repeat steps 1-5 for the other leg of the universal joint.

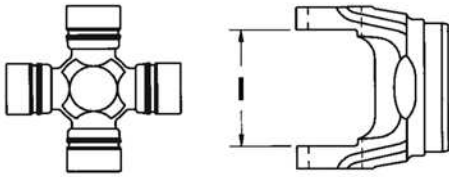

Round Outside Lock-Up/Snap Ring (OSR)

This universal joint design uses round bearing cups with a flat ground back surface. The cups are retained in the yoke by a snap ring that locks into a groove in the yoke crosshole.

1. Assemble bearing cups onto cross.
2. Remove rubber seals or clamp bearing cups with a C-clamp or vise.
3. Measure across the outside of the two bearing cups.
4. Measure outside diameters of the bearing cups. Conversion joints and some OE applications use two different diameter bearing cups.
5. For conversion type universal joints repeat steps 1-4 for the other leg of the universal joint.

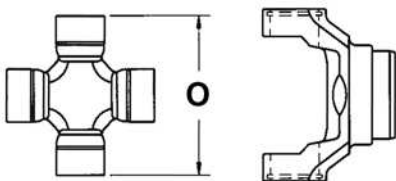

Plastic injection

This style of lock-up was used in OEM Saginaw & AAM applications. When disassembled, OE joints are replaced with standard universal joint kits using round inside lock-up/snap rings.

U-Bolt & bearing strap

These two types of universal joints use round bearings secured in the yoke ears by a U-shaped bolt or strap that fits over the bearing cups. Measure in the same manner as round ISR or OSR.

Round w/Plate

These universal joint kits use a flat plate welded to the back surface of the bearing cups. Two bolts retain each bearing in the yoke ears. Heavy Duty series using this style are 1610, 1710, 1760, and 1810. Basic reference dimensions required to identify each one are listed below. Measure between the inside surfaces of the retainer plates or across the outside surfaces of the yoke ears.

Lock-Up	Series	Kit no.
5.312	1610	UJ333
6.094	1710	UJ334
7.000	1760	UJ376
7.547	1810	UJ382

Mechanics design (Wing bearings)

This universal joint design uses a block- or wing-style bearing cup that locates in a flat flange-type yoke with a tongue and groove arrangement. Identify the bearing shape on the previous diagram. Some applications use two different bearing types.

1. Assemble bearing cups onto cross.
2. Clamp the bearings with C-clamp or vise.
3. Measure across two opposite bearings, in the same manner as round outside lock-up/snap ring to obtain the yoke lock-up.
4. Measure the cap holes CL to CL (centerline to centerline) to identify the series.
5. Identify the proper cup (Bearing Type) DWT, HWD, LWD, or LWT.

How to use this catalog

Application section

1. Locate Manufacturer.
 - Manufacturer's are listed in alphabetical order (refer to "Manufacturer's index" or correct page number)
2. Locate Model.
 - Models are listed within each manufacturer's section
3. Locate year.
4. Locate your application information.
5. Locate position.
 - Location number is located next to location description.
6. Locate the location number on the application drawing.
 - Application drawing is below the application listings at the bottom of the page.
7. Locate standard part.
8. Locate Brute Force Greaseable.
9. Locate Brute Force Non Greaseable.

Ford (RWD) Mustang					
MFG./YEAR	MODEL & LOCATION	PART NO.	MFG./YEAR	MODEL & LOCATION	PART NO.
Drive Shaft			Drive Shaft (Cont.)		
U-Joint			U-Joint (Cont.)		
2021-2015 Mustang w/ Man. Trans. Exc. 8 Cyl. Eng.: [Type 1]			1995-1994 Mustang w/ 6 Cyl. Eng.: [Type 1]		
	U-Joint (Front) ①	UJ331		U-Joint (Front) ①	UJ369
	Brute Force Greaseable	UJ232		Brute Force Greaseable	UJ280
	Brute Force Non Greaseable	UJ231		Brute Force Non Greaseable	UJ269
	(For Aluminum Drive Shaft)	UJ331C		(For Aluminum Drive Shaft)	UJ369C
	U-Joint (Rear) ②	UJ331		U-Joint (Rear) ②	UJ369
	Brute Force Greaseable	UJ232		Brute Force Greaseable	UJ280
	Brute Force Non Greaseable	UJ231		Brute Force Non Greaseable	UJ269
	(For Aluminum Drive Shaft)	UJ331C		(For Aluminum Drive Shaft)	UJ369C
2020-2015 Mustang w/ 8 Cyl. Eng.: [Type 4]			1995-1994 Mustang w/ 8 Cyl. Eng.: [Type 1]		
	U-Joint (Front) ①	UJ331		U-Joint (Front) ①	UJ354
	Brute Force Greaseable	UJ232		Brute Force Greaseable	UJ270
	Brute Force Non Greaseable	UJ231		Brute Force Non Greaseable	UJ254
	(For Aluminum Drive Shaft)	UJ331C		(For Aluminum Drive Shaft)	UJ354C
	U-Joint (Rear) ②	UJ331		U-Joint (Rear) ②	UJ354
	Brute Force Greaseable	UJ232		Brute Force Greaseable	UJ270
	Brute Force Non Greaseable	UJ231		Brute Force Non Greaseable	UJ254
	(For Aluminum Drive Shaft)	UJ331C		(For Aluminum Drive Shaft)	UJ354C

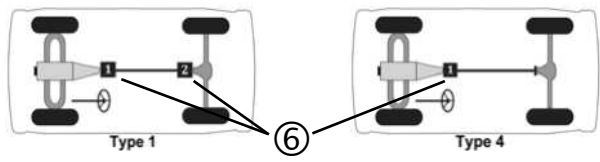

Footnote codes

- For use w/U-Bolt Application.
- For use w/o U-Bolt Application.
- ▲ For use w/1.063" Bearing Cap Application.
- ⊙ For use w/1.188" Bearing Cap Application.
- ◇ For use w/Inner Lock Ring Application on Half Shaft.
- For use w/Outer Lock Ring Application on Half Shaft.

Manufacturer index

Manufacturer	Page
PASSENGER CARS	
ALFA ROMEO.....	1
AMERICAN MOTORS.....	1
AUDI.....	5
AUSTIN.....	6
AUSTIN-HEALEY.....	6
BMW.....	6
BMW CUV.....	7
BUICK.....	8
CADILLAC.....	12
CHECKER MOTORS.....	17
CHEVROLET.....	17
CHRYSLER.....	25
DAIHATSU.....	27
DODGE.....	27
DODGE CUV.....	31
EAGLE.....	31
EDSEL.....	31
FIAT.....	31
FORD.....	32
HYUNDAI.....	44
HYUNDAI CUV.....	44
JAGUAR.....	44
LINCOLN.....	45
LOTUS.....	48
MAZDA.....	48
MERCEDES-BENZ.....	49
MERCEDES BENZ CUV.....	50
MERCURY.....	50
METROPOLITAN.....	58
MG.....	58
MINI.....	59
MORRIS.....	59
NISSAN/DATSUN.....	59
OLDSMOBILE.....	60
PLYMOUTH.....	64
PONTIAC.....	66
PORSCHE.....	71
ROLLS ROYCE.....	71
SRT.....	72
STUDEBAKER.....	72
SUBARU.....	72
SUNBEAM.....	73
SUZUKI.....	73
TOYOTA.....	74
TRIUMPH.....	75
VOLKSWAGEN.....	75
VOLVO.....	76

Manufacturer	Page
LIGHT & MED. DUTY TRUCKS (2 WD & 4 WD) and VANS	
ACURA.....	79
BUICK.....	79
CADILLAC.....	79
CHEVROLET/GMC.....	81
Vans.....	89
1/2 Ton Trucks.....	105
3/4 Ton Trucks.....	159
1 Ton Trucks.....	194
1 1/2 Ton Trucks.....	217
CHRYSLER.....	219
DODGE.....	220
Vans.....	221
1/2 Ton Trucks.....	224
3/4 Ton Trucks.....	245
1 Ton Trucks.....	274
1 1/2 Ton Trucks.....	300
FORD.....	300
Vans.....	342
1/2 Ton Trucks.....	356
3/4 Ton Trucks.....	384
1 Ton Trucks.....	444
1 1/2 Ton Trucks.....	483
GEO.....	485
HINO.....	485
HONDA.....	487
HUMMER.....	488
IHC.....	489
INFINITI.....	491
ISUZU.....	492
JEEP.....	497
KIA.....	517
LEXUS.....	518
LINCOLN.....	519

Manufacturer	Page
MAZDA.....	522
MERCURY.....	526
MINI.....	528
NISSAN.....	530
OLDSMOBILE.....	536
PLYMOUTH.....	536
PONTIAC.....	539
RAM.....	539
1/2 Ton Trucks.....	539
3/4 Ton Trucks.....	541
1 Ton Trucks.....	543
1 1/2 Ton Truck.....	546
ROVER.....	547
SAAB.....	548
SATURN.....	549
SUBARU.....	549
TOYOTA.....	549
VOLKSWAGEN.....	558

Notes



WARNING!

Proper selection of the products listed for sale in this catalog is essential to minimize the risk of any seal, bearing or other product failure. Such failures can result in property damage or severe personal injury to operators of machinery, vehicles or to others. You must carefully evaluate the particular application on or into which you intend to install the products. Products in this catalog require installation by an experienced professional mechanic or qualified maintenance professional.

The product properties and operating parameters described in this catalogue are based upon tests conducted by SKF or reported by others. SKF does not assume any responsibility for errors in the data published in this catalog. The life and performance of the products ultimately depend on a number of factors. These include, for example, selection of product design type, selection of materials for their different properties, handling and installation, operating conditions, including shaft surface or bore conditions, the quantity, quality and chemistry of lubricants and other factors. Severe environments can adversely affect product life or performance. For help in realizing longer SKF product life, and optimal performance for your specific application, contact SKF's Customer Services Department at 1-800-882-0008.

LIMITED WARRANTY

SKF warrants to the first purchaser that the products sold by it, when properly installed, will be free from defects in material and workmanship. SKF's sole obligation and liability for any defect found to exist contrary to this limited warranty in a product sold by SKF, and purchaser's sole and exclusive remedy for such defect, shall be limited to: (A) SKF furnishing without additional charge to purchaser, including transportation, a replacement for any of the products sold by SKF which are found by SKF to be defective contrary to this limited warranty, and (B) in the case of products which cannot be repaired or replaced by SKF, SKF shall credit or refund to purchaser the purchase price paid therefore; provided, that SKF must be advised in writing of any product non-conformance within thirty (30) days of the date of the discovery thereof, and the non-conforming product must be returned f.o.b. to SKF's designated warehouse promptly, but in no event after the expiration of the warranty period applicable to the product as follows: (1) Products (light duty hub units and timing chain kits excepted) are warranted by SKF for a period of twelve (12) months from the date of purchase; (2) light duty hub bearing units are warranted for a period of sixty (60) months from the date of purchase, or 60,000 miles (100,000 kilometers), whichever occurs first; (3) timing chain kits are warranted for a period of twenty-four (24) months from the date of purchase, or 30,000 miles (48,000 kilometers), whichever occurs first; and (4) U-Joints are subject to a limited lifetime warranty. Valid proof of purchase date/mileage required. In no event shall SKF be obligated under this limited warranty or otherwise in any way whatsoever for normal wear and tear, or for any products sold by SKF which, after delivery by SKF and in SKF's sole determination, have been subjected to accident, abuse, misapplication, improper or faulty repair or installation, improper or faulty maintenance or lubrication, any alteration or neglect, excessive loading or other excessive operating conditions, or for defects caused by or resulting from purchaser's specifications or designs or otherwise caused by purchaser. TO THE FURTHEST EXTENT PERMITTED UNDER APPLICABLE LAW, SKF DISCLAIMS LIABILITY, IN TORT OR CONTRACT, IN NEGLIGENCE, STRICT LIABILITY, OR OTHERWISE, FOR ANY OTHER REMEDY OR DAMAGE, WHETHER DIRECT OR INDIRECT, INCIDENTAL, SPECIAL, EXEMPLARY, OR CONSEQUENTIAL WITH RESPECT TO ITS PERFORMANCE HEREUNDER, INCLUDING WITHOUT LIMITATION THE PRODUCTS SOLD OR PROVIDED HEREUNDER BY SKF, AND ITS PROVISION OF ANY RELATED SERVICES. THIS LIMITED WARRANTY IS TO THE EXCLUSION OF ALL OTHER WARRANTIES, EXPRESS OR IMPLIED, INCLUDING WARRANTIES OF MERCHANTABILITY OR FITNESS FOR A PARTICULAR PURPOSE. COSTS INCURRED FOR ROUTINE MAINTENANCE ARE NOT COVERED BY THIS LIMITED WARRANTY. Without limiting the generality of the foregoing, SKF specifically disclaims liability to purchaser for any loss, cost, or damage incurred as a result of equipment downtime, or loss of use or availability of worksite, lost revenues or lost profits, regardless of whether SKF is on notice of the possibility of such damage or loss and did or could have anticipated same. No other person has been authorized by SKF to undertake or make on behalf of SKF any further representation, warranty or guarantee in addition to or contrary to this limited warranty or contrary to the limitations and disclaimers provided herein. The exclusive remedies provided in this limited warranty shall not be deemed to have failed of their essential purpose so long as SKF is willing and able to perform to the extent and in the manner prescribed in this limited warranty.

SOME STATES DO NOT ALLOW LIMITATIONS ON HOW LONG AN IMPLIED WARRANTY LASTS OR THE EXCLUSION OR LIMITATION OF INCIDENTAL OR CONSEQUENTIAL DAMAGES, SO THE ABOVE EXCLUSIONS OR LIMITATIONS MAY NOT APPLY TO YOU. This limited warranty gives you specific legal rights, and you may also have other rights, which vary state to state.

INFORMATION AND RETURNS: This catalog refers to products as designed prior to its publication, and does not cover product changes made after its publication date. Inquiries can be directed to: SKF Customer Service Department, 890 North State Street, Suite 200, Elgin, IL 60123, or call 1-800-882-0008. Any error in shipment (for over-shipments in the quantity of product or for product not matching purchaser's description given in its order) is returnable for credit or replacement by SKF, provided that SKF is advised in writing by purchaser of such non-conformance within 30 days after the product's delivery to purchaser, and only after written authorization therefore is given by SKF. Approved returns must be shipped freight prepaid and arrive in good, saleable condition to qualify for credit or replacement. SKF shall not otherwise be obligated to accept the return of any products sold or distributed by it.

NOTICE: The SKF part numbering systems for the SKF products are proprietary to SKF. Any improper or unauthorized use of these numbering systems, including adoption or use of any of their part numbers or part number lists, even where the subject of modification or addition, is strictly prohibited and will be prosecuted by SKF as a violation of U.S. and foreign copyright, trademark and unfair competition laws. In addition, use of any SKF trademarks, trade names or packaging schemes, systems, colors or designs is likewise considered a violation of the trademarks, trade names and trade identities rights of SKF USA Inc. and their affiliates. Possible violation of such use should be brought to the attention of SKF: SKF USA Inc., 890 Forty Foot Road, Lansdale, PA 19446, Attn: Catalog Manager.

Tabla de contenido

Introducción

Identificación de Cruceta	2B
Cómo usar este catálogo.....	3B
Índice de Fabricante	4B

Aplicaciones

Aplicaciones de auto de pasajero de Tracción Trasera	1
Aplicaciones de camiones de uso ligero y mediano 2WD y 4WD	8
Servicio Pesado	573

Partes Relacionadas a la Cruceta

Partes doble cardan de VC.....	559
Lista de componentes del kit de Cruceta	561

Dimensiones de la Cruceta

Dimensiones del Tornillo en Forma U	563
Crucetas con 4 rodamientos redondos lisos.....	564
Crucetas con 4 rodamientos redondos lisos.....	567
Crucetas con 2 rodamientos acanalados y 2 rodamientos redondos lisos	571
Acoplador flexible del eje de transmisión SKF.....	572
Crucetas con 4 rodamientos redondos de placa soldada	578
Crucetas con 2 rodamientos redondos de placa soldada y 2 rodamientos redondos lisos.....	578
Crucetas con 4 rodamientos de aleta.....	579
Crucetas con 2 rodamientos de aleta y 2 rodamientos redondos acanalados.....	582
Crucetas con 2 rodamientos de aleta y 2 rodamientos redondos lisos o 2 rodamientos redondos de placa soldada.....	583

Identificación de Cruceta

Anillo Redondo Interno de Bloqueo/ Retención (ISR, por sus siglas en Inglés)

Este diseño de Cruceta utiliza tazas de rodamiento redondas con una ranura de retención anular en el diámetro exterior de los rodamientos y superficies planas mecanizadas en el interior de las espigas de la horquilla. Es más fácil medir el bloqueo para este tipo, midiendo la horquilla de espiga interior a espiga interior. Si la horquilla no está disponible, el bloqueo se puede medir en la misma Cruceta.

1. Ensamble las tazas de rodamiento en la cruz.
2. Instale los anillos de retención en las ranuras de los rodamientos.
3. Quite los sellos de hule o sujete las tazas de los rodamientos con una prensa C o una prensa de banco.
4. Mida a través de la parte exterior de los dos anillos de retención instalados frente a frente para obtener la dimensión de bloqueo.
5. Mida el diámetro exterior de las tazas de rodamientos. Las crucetas de conversión y algunas aplicaciones OE pueden tener dos diámetros de tazas de rodamientos diferentes.
6. Para crucetas universales de tipo conversión, repita los pasos del 1 al 5 para la otra pata de la Cruceta.

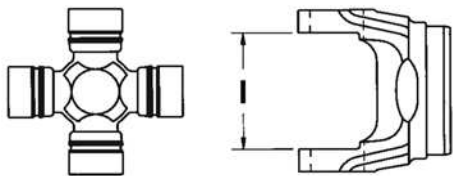

Anillo Redondo Externo de Bloqueo/ Retención (OSR, por sus siglas en Inglés)

Este diseño de Cruceta utiliza tazas de rodamientos redondas con una superficie mecanizada posterior plana. Las tazas se mantienen en la horquilla por un anillo de retención que encaja en una ranura en el agujero transversal de la horquilla.

1. Ensamble las tazas de rodamiento en la cruz.
2. Quite los sellos de hule o sujete las tazas de los rodamientos con una prensa C o una prensa de banco.
3. Mida a través de la parte exterior de las dos tazas de rodamiento.
4. Mida el diámetro exterior de las tazas de rodamientos. Las crucetas de conversión y algunas aplicaciones OE usan dos diámetros de tazas de rodamientos diferentes.
5. Para crucetas universales de tipo conversión, repita los pasos del 1 al 4 para la otra pata de la Cruceta.

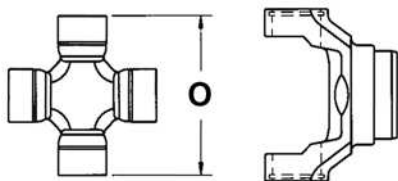

Inyección plástica

Este estilo de bloqueo se usó en aplicaciones OEM de Saginaw y AAM. Cuando están desensamblados, las crucetas OE se sustituyen con kits de Cruceta estándar usando anillos redondos de bloqueo/retención.

Tornillo en Forma U y correa de rodamiento

Estos dos tipos de crucetas universales utilizan rodamientos redondos sujetos en las espigas de la horquilla por un perno en forma de U o una correa que se ajusta sobre las tazas de rodamiento. Mida de la misma forma que los ISR o OSR redondos.

Redondo con Placa

Estos kits de crucetas universales usan una placa plana soldada a la superficie posterior de las tazas de rodamientos. Dos pernos retienen cada rodamiento en las espigas de la horquilla. Series de Servicio Pesado que usan este estilo son las 1610, 1710, 1760, y 1810. Las dimensiones de referencias básicas necesarias para identificar cada una se indican a continuación. Mida entre las superficies interiores de las placas de retención o a través de las superficies exteriores de las espigas de la horquilla.

Bloqueo	Serie	No. de Kit
5.312	1610	UJ333
6.094	1710	UJ334
7.000	1760	UJ376
7.547	1810	UJ382

Diseño de Mecánico (Rodamientos de aleta)

Este diseño de Cruceta utiliza una copa del rodamiento de bloque o de estilo de aleta que se coloca en un yugo de tipo de brida plana con una estructura de ranura y lengüeta. Identifique la forma de rodamiento en el diagrama anterior. Algunas aplicaciones usan dos tipos de rodamientos diferentes..

1. Ensamble las tazas de rodamiento en la cruz.
2. Sujete los rodamientos con una prensa C o una prensa de banco.
3. Mida a través de dos cojinetes opuestos, de la misma manera que un anillo redondo externo de bloqueo/retención para obtener el bloqueo de la horquilla.
4. Mida los agujeros de las tazas de LC a LC (Línea central a línea central) para identificar la serie.
5. Identifique la copa correcta (Tipo de Rodamiento) DWT, HWD, LWD o LWT.

Cómo usar este catálogo

Sección de Aplicación

1. Ubique el Fabricante.
 - Los fabricantes están enlistados en orden alfabético (consulte el "Índice de fabricantes" o el número de página correcto)
2. Ubique el Modelo.
 - Los modelos están enlistados dentro de la sección de cada fabricante
3. Ubique el Año.
4. Ubique su información de aplicación.
5. Ubique la posición.
 - El número de ubicación se encuentra junto a la descripción de la ubicación.
6. Ubique el número de ubicación en el dibujo de la aplicación.
 - El dibujo de la aplicación se encuentra debajo de las listas de aplicaciones en la parte inferior de la página.
7. Ubique la parte estándar.
8. Ubique la Brute Force Engrasable.
9. Ubique la Brute Force No Engrasable.

MFG./YEAR	MODEL & LOCATION	PART NO.	MFG./YEAR	MODEL & LOCATION	PART NO.
Ford (RWD) Mustang			Ford (RWD) Mustang		
Drive Shaft			Drive Shaft (Cont.)		
	U-Joint			U-Joint (Cont.)	
	2021-2015 Mustang w/ Man. Trans. Exc. 8 Cyl. Eng.: [Type 1]			1995-1994 Mustang w/ 6 Cyl. Eng.: [Type 1]	
	U-Joint (Front)❶	UJ331		U-Joint (Front)❶	UJ369
	Brute Force Greaseable	UJ232		Brute Force Greaseable	UJ280
	Brute Force Non Greaseable	UJ231		Brute Force Non Greaseable	UJ269
	(For Aluminum Drive Shaft)	UJ331C		(For Aluminum Drive Shaft)	UJ369C
	U-Joint (Rear)❷	UJ331		U-Joint (Rear)❷	UJ369
	Brute Force Greaseable	UJ232		Brute Force Greaseable	UJ280
	Brute Force Non Greaseable	UJ231		Brute Force Non Greaseable	UJ269
	(For Aluminum Drive Shaft)	UJ331C		(For Aluminum Drive Shaft)	UJ369C
	2020-2015 Mustang w/ 8 Cyl. Eng.: [Type 4]			1995-1994 Mustang w/ 8 Cyl. Eng.: [Type 1]	
	U-Joint (Front)❶	UJ331		U-Joint (Front)❶	UJ354
	Brute Force Greaseable	UJ232		Brute Force Greaseable	UJ270
	Brute Force Non Greaseable	UJ231		Brute Force Non Greaseable	UJ254
	(For Aluminum Drive Shaft)	UJ331C		(For Aluminum Drive Shaft)	UJ354C
	U-Joint (Rear)❷	UJ331		U-Joint (Rear)❷	UJ354
	Brute Force Greaseable	UJ232		Brute Force Greaseable	UJ270
	Brute Force Non Greaseable	UJ231		Brute Force Non Greaseable	UJ254
	(For Aluminum Drive Shaft)	UJ331C		(For Aluminum Drive Shaft)	UJ354C

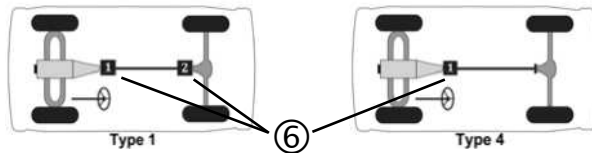

Códigos de nota de pie de página

- Para usar en Aplicación con tornillo en forma U.
- Para usar en Aplicación sin tornillo en forma U.
- ▲ Para usar en Aplicación con Tapa de Rodamiento de 1.063".
- Para usar en Aplicación con Tapa de Rodamiento de 1.188".
- ◇ Para usar en Aplicación con Anillo de Retención Interior en Medio Eje.
- Para usar en Aplicación con Anillo de Retención Exterior en Medio Eje.

Índice de Fabricante

Fabricante Página

AUTOMÓVILES DE PASAJEROS

ALFA ROMEO	1
AMERICAN MOTORS.....	1
AUDI.....	5
AUSTIN	6
AUSTIN-HEALEY.....	6
BMW.....	6
BMW CUV.....	7
BUICK.....	8
CADILLAC	12
CHECKER MOTORS	17
CHEVROLET.....	17
CHRYSLER	25
DAIHATSU	27
DODGE.....	27
DODGE CUV.....	31
EAGLE.....	31
EDSEL.....	31
FIAT	31
FORD.....	32
HYUNDAI	44
HYUNDAI CUV.....	44
JAGUAR.....	44
LINCOLN.....	45
LOTUS.....	48
MAZDA.....	48
MERCEDES-BENZ.....	49
MERCEDES BENZ CUV.....	50
MERCURY.....	50
METROPOLITAN	58
MG	58
MINI.....	59
MORRIS	59
NISSAN/DATSUN.....	59
OLDSMOBILE.....	60
PLYMOUTH	64
PONTIAC.....	66
PORSCHE	71
ROLLS ROYCE	71
SRT.....	72
STUDEBAKER.....	72
SUBARU.....	72
SUNBEAM	73
SUZUKI.....	73
TOYOTA.....	74
TRIUMPH	75
VOLKSWAGEN.....	75
VOLVO.....	76

Fabricante Página

CAMIONES LIGEROS y MEDIANOS (2 WD y 4 WD) y VANS

ACURA.....	79
BUICK.....	79
CADILLAC.....	79
CHEVROLET/GMC.....	81
Vans.....	89
1/2 Ton Trucks.....	105
3/4 Ton Trucks.....	159
1 Ton Trucks.....	194
1 1/2 Ton Trucks.....	217
CHRYSLER.....	219
DODGE.....	220
Vans.....	221
1/2 Ton Trucks.....	224
3/4 Ton Trucks.....	245
1 Ton Trucks.....	274
1 1/2 Ton Trucks.....	300
FORD.....	300
Vans.....	342
1/2 Ton Trucks.....	356
3/4 Ton Trucks.....	384
1 Ton Trucks.....	444
1 1/2 Ton Trucks.....	483
GEO.....	485
HINO.....	485
HONDA.....	487
HUMMER.....	488
IHC.....	489
INFINITI.....	491
ISUZU.....	492
JEEP.....	497
KIA.....	517
LEXUS.....	518

Fabricante Página

LINCOLN.....	519
MAZDA.....	522
MERCURY.....	526
MINI.....	528
NISSAN.....	530
OLDSMOBILE.....	536
PLYMOUTH.....	536
PONTIAC.....	539
RAM.....	539
1/2 Ton Trucks.....	539
3/4 Ton Trucks.....	541
1 Ton Trucks.....	543
1 1/2 Ton Truck.....	546
ROVER.....	547
SAAB.....	548
SATURN.....	549
SUBARU.....	549
TOYOTA.....	549
VOLKSWAGEN.....	558

Notas



ADVERTENCIA!

La selección adecuada de los productos que figuran a la venta en este catálogo es esencial para minimizar el riesgo de que se produzcan fallos en los sellos, casquillos u otro tipo de fallo en el producto. Dichos fallos pueden provocar daños a la propiedad o lesiones personales graves a los operadores de maquinaria, vehículos o a otras personas. Debe evaluar cuidadosamente la aplicación particular en la que pretende instalar los productos. Los productos de este catálogo requieren ser instalados por un mecánico profesional experimentado o un profesional de mantenimiento capacitado.

Las propiedades del producto y los parámetros de funcionamiento descritos en este catálogo se basan en ensayos realizados por SKF o comunicados por otros. SKF no asume responsabilidad alguna por los errores en los datos publicados en este catálogo. La vida útil y el rendimiento de los productos dependen en última instancia de una serie de factores. Estos incluyen, por ejemplo, la selección del tipo de diseño del producto, la selección de los materiales por sus diferentes propiedades, la manipulación y la instalación, las condiciones de funcionamiento, incluidas las condiciones de la superficie del eje o del agujero, la cantidad, la calidad y la química de los lubricantes y otros factores. Los entornos severos pueden afectar de manera negativa a la vida útil o al rendimiento del producto. Para obtener ayuda para lograr una mayor vida útil de los productos SKF y un rendimiento óptimo para su aplicación específica, comuníquese con el Departamento de Atención al Cliente de SKF por teléfono al 1-800-882-0008.

GARANTÍA LIMITADA

SKF garantiza al primer comprador que los productos vendidos por éste, cuando estuviesen instalados de manera correcta, no contendrán defectos de material y fabricación. La única obligación y responsabilidad de SKF por cualquier defecto contrario a esta garantía limitada en un producto vendido por SKF y el único y exclusivo recurso del comprador para dicho defecto, se limitará a: (A) el suministro por parte de SKF, sin cargo adicional para el comprador, incluido el transporte, de un reemplazo para cualquiera de los productos vendidos por SKF que se encontrasen defectuosos en contra de esta garantía limitada y (B) en el caso de productos que no pudiesen ser reparados o reemplazados por SKF, SKF acreditará o reembolsará al comprador el precio de compra pagado por ello; se establece que se debe notificar a SKF por escrito de cualquier disconformidad del producto dentro de los treinta (30) días siguientes a la fecha de su descubrimiento y el producto no conforme debe devolverse franco a bordo al almacén designado por SKF con prontitud, pero en ningún caso después del vencimiento del período de garantía aplicable al producto, tal como se indica a continuación: (1) los productos (excepto las unidades de cubo de carga ligera y los kits de cadena de distribución) están garantizados por SKF durante un período de doce (12) meses a partir de la fecha de compra; (2) las unidades de rodamiento de cubo de carga ligera están garantizadas durante un período de sesenta (60) meses a partir de la fecha de compra o 60.000 millas (100.000 kilómetros), lo que ocurriese primero; (3) los kits de cadena de distribución están garantizados por un período de veinticuatro (24) meses a partir de la fecha de compra o 30.000 millas (48.000 kilómetros), lo que ocurriese primero y (4) las juntas en U están sujetas a una garantía limitada de por vida. Se requiere una prueba válida de la fecha de compra/millaje. En ningún caso SKF estará obligada, en virtud de esta garantía limitada o de cualquier otro modo, por el desgaste normal o por cualquier producto vendido por SKF que, después de la entrega por parte de SKF y según la única determinación de SKF, se hubiese sometido a un accidente, a un abuso, a una aplicación incorrecta, a una reparación o instalación incorrecta o defectuosa, a un mantenimiento o lubricación incorrecta o defectuosa, a cualquier alteración o negligencia, a una carga excesiva o a otras condiciones de funcionamiento excesivas o por defectos causados o resultantes de las especificaciones o diseños del comprador o causados de otro modo por el comprador. **ESTRICTA O DE OTRO TIPO, POR CUALQUIER OTRO RECURSO O DAÑO, YA SEA DIRECTO O INDIRECTO, INCIDENTAL, ESPECIAL, EJEMPLAR O CONSECUENTE CON RESPECTO A SU DESEMPEÑO EN ESTE DOCUMENTO, INCLUIDOS, ENTRE OTROS, LOS PRODUCTOS VENDIDOS O SUMINISTRADOS POR SKF EN ESTE DOCUMENTO Y SU PRESTACIÓN DE CUALQUIER SERVICIO RELACIONADO. ESTA GARANTÍA LIMITADA EXCLUYE TODAS LAS DEMÁS GARANTÍAS, EXPRESAS O IMPLÍCITAS, INCLUIDAS LAS GARANTÍAS DE COMERCIABILIDAD O IDONEIDAD PARA UN FIN DETERMINADO. LOS COSTOS DEL MANTENIMIENTO DE RUTINA NO ESTÁN CUBIERTOS POR ESTA GARANTÍA LIMITADA.** Sin limitar la generalidad de lo anterior, SKF rechaza de manera específica la responsabilidad ante el comprador por cualquier pérdida, coste o daño incurridos como resultado del tiempo de inactividad del equipo o la pérdida de uso o disponibilidad del lugar de trabajo, la pérdida de ingresos o la pérdida de beneficios, independientemente de si SKF estuviese al corriente de la posibilidad de dichos daños o pérdidas y de si los hubiese previsto o podría haberlos previsto. Ninguna otra persona ha sido autorizada por SKF para asumir o hacer en nombre de SKF cualquier otra declaración, garantía o aval que se sumase o fuese contrario a esta garantía limitada o que fuese contrario a las limitaciones y renunciaciones aquí previstas. No se considerará que los recursos exclusivos previstos en esta garantía limitada hayan dejado de cumplir su propósito esencial mientras SKF estuviese dispuesta y fuese capaz de cumplir en la medida y de la manera prescrita en esta garantía limitada.

ALGUNOS ESTADOS NO PERMITEN LA LIMITACIÓN DE LA DURACIÓN DE UNA GARANTÍA IMPLÍCITA O LA EXCLUSIÓN O LIMITACIÓN DE LOS DAÑOS INCIDENTALES O CONSECUENTES, POR LO QUE LAS EXCLUSIONES O LIMITACIONES ANTERIORES PUEDEN NO SERLE APLICABLES. Esta garantía limitada le otorga derechos legales específicos y también puede tener otros derechos, que varían de un estado a otro.

INFORMACIÓN Y DEVOLUCIONES: este catálogo se refiere a los productos tal y como se diseñaron antes de su publicación y no cubre los cambios de productos realizados después de su fecha de publicación. Las consultas pueden dirigirse a: SKF Customer Service Department, 890 North State Street, Suite 200, Elgin, IL 60123 o llamar al 1-800-882-0008. Cualquier error en el envío (por exceso en la cantidad de producto o por producto que no coincidiese con la descripción dada por el comprador en su pedido) puede ser devuelto por SKF para su abono o sustitución, siempre que el comprador avisara a SKF por escrito de dicha disconformidad en un plazo de 30 días después de la entrega del producto al comprador y solo después de que SKF lo autorizara por escrito. Las devoluciones aprobadas deben enviarse a fletes pagados y llegar en buenas condiciones de venta para poder optar a un crédito o a una sustitución. SKF no estará obligada a aceptar la devolución de ningún producto vendido o distribuido por ella.

AVISO: los sistemas de numeración de piezas de los productos SKF son propiedad de SKF. Cualquier uso inadecuado o no autorizado de estos sistemas de numeración, incluida la adopción o el uso de cualquiera de sus números de pieza o listas de números de pieza, incluso cuando fuesen objeto de modificación o adición, está estrictamente prohibido y será perseguido por SKF como una infracción a las leyes de derechos de autor, marcas comerciales y competencia desleal de los EE. UU. y del extranjero. Además, el uso de cualquier marca registrada, nombre comercial o esquema de embalaje, sistemas, colores o diseños de SKF se considera igualmente una violación de los derechos de marcas, nombres comerciales e identidades comerciales de SKF USA Inc. y sus filiales. La posible violación de dicho uso debe ser puesta en conocimiento de SKF: SKF USA Inc., 890 Forty Foot Road, Lansdale, PA 19446, Attn: Catalog Manager.

Table des matières

Introduction

Identification des joints de cardan.....	2C
Mode d'emploi de ce catalogue	3C
Index des fabricants.....	4C

Applications

Applications pour voitures de tourisme à propulsion.....	1
Applications pour camionnettes légères et moyennes à 2 et 4 roues motrices	78
Véhicules lourds.....	573

Pièces connexes de joints de cardan

Pièces de joint à double cardan homocinétique	559
Liste des pièces de fixation de joints de cardan	561

Dimensions des joints de cardan

Dimensions des étriers de fixation	563
Joints de cardan à 4 roulements ronds rainurés	564
Joints de cardan à 4 roulements ronds simples.....	567
Joints de cardan à 2 roulements ronds rainurés et 2 roulements ronds simples	571
Coupleur flexible d'arbre de transmission SKF.....	572
Joints de cardan à 4 roulements ronds de type à plaque soudée	578
Joints de cardan à 2 roulements ronds de type à plaque soudée et 2 roulements ronds simples.....	578
Joints de cardan à 4 roulements à ailettes	579
Joints de cardan à 2 roulements à ailettes et 2 roulements ronds rainurés	582
Joints de cardan à 2 roulements à ailettes et 2 roulements ronds simples ou 2 roulements ronds à plaque soudée	583

Identification des joints de cardan

Circlip à blocage intérieur rond

Cette conception de joint de cardan utilise des cuvettes de roulement ronds dotées d'une rainure à circlip sur le diamètre externe des paliers et des surfaces plates usinées sur la face interne des oreilles de la chape. Il est plus facile de mesurer le blocage pour ce type de joint en mesurant la chape d'une oreille interne à l'autre. Si la chape n'est pas disponible, le blocage peut se mesurer sur le joint de cardan proprement dit.

1. Assemblez les cuvettes de roulement sur le croisillon.
2. Montez les circlips dans les rainures de roulement.
3. Retirez les bouchons en caoutchouc ou serrez les cuvettes de roulement avec un serre-joint ou un étau.
4. Mesurez à travers l'extérieur des deux circlips montés en face à face pour obtenir la dimension du de blocage.
5. Mesurez les diamètres extérieurs des cuvettes de roulement. Les joints de conversion et certaines applications d'équipement d'origine peuvent présenter deux diamètres de cuvettes de roulement différentes.
6. Pour les joints de cardan de type conversion, répétez les étapes 1 à 5 pour l'autre patte du joint de cardan.

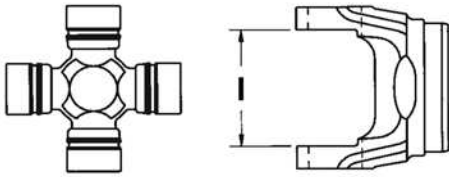

Circlip à blocage extérieur rond

Cette conception de joint de cardan utilise des cuvettes de roulement rondes avec une surface arrière rectifiée plate. Les cuvettes sont maintenues dans la chape par un circlip qui se verrouille dans une rainure de l'orifice de la chape.

1. Assemblez les cuvettes de roulement sur le croisillon.
2. Retirez les bouchons en caoutchouc ou serrez les cuvettes de roulement à l'aide d'un serre-joint ou d'un étau.
3. Mesurez à travers l'extérieur des deux cuvettes de roulement.
4. Mesurez les diamètres extérieurs des cuvettes de roulement. Les joints de conversion et certaines applications d'équipement d'origine utilisent deux diamètres de cuvettes de roulement différentes.
5. Pour les joints de cardan de type conversion, répétez les étapes 1 à 4 pour l'autre patte du joint de cardan.

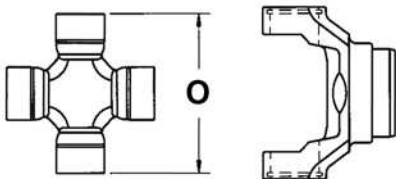

Injection de matière plastique

Ce type de blocage a été utilisé dans des applications d'équipement d'origine Saginaw et AAM. Lors du démontage, les joints d'origine sont remplacés par des trousse de joints de cardan standard utilisant des circlips ronds à blocage intérieur.

Étrier de fixation et courroie de retenue

Ces deux types de joints de cardan utilisent des roulements ronds assujettis aux oreilles de chape par un étrier de fixation ou une courroie de retenue qui s'ajuste sur les cuvettes de roulement. Mesurez de la même manière que les circlips ronds à blocage intérieur ou extérieur.

Rond avec plaque

Ces trousse de joints de cardan utilisent une plaque plate soudée à la surface arrière des cuvettes de roulement. Deux boulons maintiennent chaque roulement dans les oreilles de la chape. Les séries pour véhicules lourds utilisant ce type sont les séries 1610, 1710, 1760 et 1810. Des dimensions de renvoi de base nécessaires exigées pour identifier chacune d'entre elles sont énumérées ci-dessous. Mesurez entre les surfaces intérieures des plaques de retenue ou en travers des surfaces extérieures des oreilles de chape.

Blocage	Série	Numéro de trousse
5,312	1610	UJ333
6,094	1710	UJ334
7,000	1760	UJ376
7,547	1810	UJ382

Conception mécanique (Roulements à ailettes)

Cette conception de joint de cardan utilise une cuvette de roulement à bloc ou de type à ailettes, qui se situe dans une chape à bride plate avec un emboîtement à rainure et languette. Identifiez la forme de roulement sur le schéma précédent. Certaines applications utilisent deux types de roulements différents.

1. Assemblez les cuvettes de roulement sur le croisillon.
2. Serrez les roulements à l'aide d'un serre-joint ou d'un étau.
3. Mesurez en travers deux roulements en vis-à-vis, de la même manière que pour le circlip à blocage extérieur rond pour obtenir le blocage de chape.
4. Mesurez les trous de capuchon de ligne médiane à ligne médiane pour identifier la série.
5. Identifiez la bonne cuvette (type de roulement) DWT, HWD, LWD ou LWT.

Mode d'emploi de ce catalogue

Section d'application

1. Localisez le fabricant.
 - Les fabricants sont énumérés par ordre alphabétique (reportez-vous à l' « Index des fabricants » ou au bon numéro de page)
2. Localisez le modèle.
 - Les modèles sont énumérés dans la section de chacun des fabricants
3. Localisez l'année.
4. Localisez les données de votre application.
5. Localisez la position.
 - Le numéro de l'emplacement est situé à côté de la description de l'emplacement.
6. Localisez le numéro de l'emplacement sur le dessin de l'application.
 - Le dessin de l'application se trouve sous les énumérations d'applications en bas de page.
7. Localisez la pièce standard.
8. Localisez « Brute Force » graissable.
9. Localisez « Brute Force » non graissable.

Ford (RWD) Mustang					
MFG./YEAR	MODEL & LOCATION	PART NO.	MFG./YEAR	MODEL & LOCATION	PART NO.
Drive Shaft			Drive Shaft (Cont.)		
U-Joint			U-Joint (Cont.)		
2021-2015 Mustang w/ Man. Trans. Exc. 8 Cyl. Eng.: [Type 1]			1995-1994 Mustang w/ 6 Cyl. Eng.: [Type 1]		
U-Joint (Front) ①		UJ331	U-Joint (Front) ⑦		UJ369
Brute Force Greaseable		UJ232	Brute Force Greaseable		UJ280 ⑧
Brute Force Non Greaseable		UJ231	Brute Force Non Greaseable		UJ269
(For Aluminum Drive Shaft)		UJ331C	(For Aluminum Drive Shaft)		UJ369C ⑨
U-Joint (Rear) ②		UJ331	U-Joint (Rear) ⑤		UJ369
Brute Force Greaseable		UJ232	Brute Force Greaseable		UJ280
Brute Force Non Greaseable		UJ231	Brute Force Non Greaseable		UJ269
(For Aluminum Drive Shaft)		UJ331C	(For Aluminum Drive Shaft)		UJ369C
2020-2015 Mustang w/ 8 Cyl. Eng.: [Type 4]			1995-1994 Mustang w/ 8 Cyl. Eng.: [Type 1]		
U-Joint (Front) ③		UJ331	U-Joint (Front) ⑥		UJ354
Brute Force Greaseable		UJ232	Brute Force Greaseable		UJ270
Brute Force Non Greaseable		UJ231	Brute Force Non Greaseable		UJ254
(For Aluminum Drive Shaft)		UJ331C	(For Aluminum Drive Shaft)		UJ354C
U-Joint (Rear) ④		UJ331	U-Joint (Rear) ⑧		UJ354
Brute Force Greaseable		UJ232	Brute Force Greaseable		UJ270
Brute Force Non Greaseable		UJ231	Brute Force Non Greaseable		UJ254
(For Aluminum Drive Shaft)		UJ331C	(For Aluminum Drive Shaft)		UJ354C

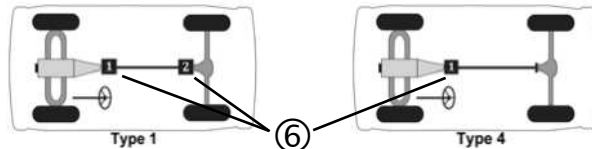

Codes de notes en bas de page

- Pour les applications avec étrier de fixation.
- Pour les applications sans étrier de fixation.
- ▲ Pour les applications à chapeau de palier de 1,063 po.
- Pour les applications à chapeau de palier de 1,188 po.
- ◇ Pour les applications à circlip intérieur sur le demi-arbre.
- Pour les applications à circlip extérieur sur le demi-arbre.

Index des fabricants

Fabricant Page

Voitures de tourisme

ALFA ROMEO	1
AMERICAN MOTORS.....	1
AUDI.....	5
AUSTIN	6
AUSTIN-HEALEY.....	6
BMW.....	6
BMW CUV.....	7
BUICK.....	8
CADILLAC	12
CHECKER MOTORS	17
CHEVROLET	17
CHRYSLER	25
DAIHATSU	27
DODGE.....	27
DODGE CUV.....	31
EAGLE.....	31
EDSEL.....	31
FIAT	31
FORD	32
HYUNDAI	44
HYUNDAI CUV	44
JAGUAR.....	44
LINCOLN.....	45
LOTUS.....	48
MAZDA.....	48
MERCEDES-BENZ	49
MERCEDES BENZ CUV.....	50
MERCURY.....	50
METROPOLITAN	58
MG	58
MINI.....	59
MORRIS	59
NISSAN/DATSUN.....	59
OLDSMOBILE	60
PLYMOUTH	64
PONTIAC.....	66
PORSCHE	71
ROLLS ROYCE	71
SRT.....	72
STUDEBAKER.....	72
SUBARU.....	72
SUNBEAM	73
SUZUKI.....	73
TOYOTA.....	74
TRIUMPH	75
VOLKSWAGEN.....	75
VOLVO	76

Fabricant Page

Camionnettes légères et moyennes (deux roues motrices et traction intégrale) et fourgonnettes

ACURA.....	79
BUICK.....	79
CADILLAC	79
CHEVROLET/GMC	81
Vans.....	89
1/2 Ton Trucks	105
3/4 Ton Trucks	159
1 Ton Trucks	194
1 1/2 Ton Trucks	217
CHRYSLER	219
DODGE.....	220
Vans.....	221
1/2 Ton Trucks	224
3/4 Ton Trucks	245
1 Ton Trucks	274
1 1/2 Ton Trucks	300
FORD	300
Vans.....	342
1/2 Ton Trucks	356
3/4 Ton Trucks	384
1 Ton Trucks	444
1 1/2 Ton Trucks	483
GEO.....	485
HINO.....	485
HONDA.....	487
HUMMER.....	488
IHC.....	489
INFINITI.....	491
ISUZU.....	492
JEEP.....	497
KIA.....	517

Fabricant Page

LEXUS.....	518
LINCOLN.....	519
MAZDA.....	522
MERCURY.....	526
MINI.....	528
NISSAN.....	530
OLDSMOBILE	536
PLYMOUTH.....	536
PONTIAC.....	539
RAM.....	539
1/2 Ton Trucks.....	539
3/4 Ton Trucks.....	541
1 Ton Trucks	543
1 1/2 Ton Truck.....	546
ROVER.....	547
SAAB	548
SATURN.....	549
SUBARU.....	549
TOYOTA.....	549
VOLKSWAGEN	558

Remarques



AVERTISSEMENT!

Il est essentiel d'effectuer le bon choix dans les produits mis en vente dans ce catalogue afin de minimiser tout risque de défaillance d'un sceau, d'un roulement ou de toute autre pièce. Ces défaillances peuvent entraîner des dommages matériels ou des blessures graves aux opérateurs de machinerie, de véhicules ou à d'autres personnes. Vous devez évaluer soigneusement l'application dans laquelle vous avez l'intention d'installer les produits. Les produits de ce catalogue doivent être installés par un mécanicien professionnel expérimenté ou par un professionnel d'entretien qualifié.

Les propriétés et les paramètres de fonctionnement des produits décrits dans ce catalogue sont basés sur des essais menés par SKF ou rapportés par d'autres sociétés. SKF décline toute responsabilité en cas d'erreurs dans les données publiées dans ce catalogue. La durée de vie et les performances des produits dépendent d'un certain nombre de facteurs, dont entre autres, les types de conception des produits, les différents matériaux employés selon leurs propriétés, la manipulation et l'installation, les conditions d'utilisation, y compris l'état de l'alésage ou de la surface de l'arbre, la quantité, la qualité et la composition chimique des lubrifiants. Des environnements rigoureux peuvent avoir un effet négatif sur la vie du produit ou sur sa performance. Pour aider à prolonger la durée de vie des produits SKF et obtenir des performances optimales pour votre application, veuillez contacter le service à la clientèle de SKF au 1-800-882-0008.

GARANTIE LIMITÉE

SKF garantit à l'acheteur original que les produits qu'elle a vendus seront, lorsque correctement installés, exempts de défauts de matériaux et de fabrication. Les seules obligations et responsabilités de SKF concernant les dommages constatés dans un produit vendu par SKF et qui sont contrairement à la présente garantie, et le seul recours exclusif de l'acheteur pour un tel défaut, se limitent aux points suivants : (A) SKF remettra à l'acheteur sans frais supplémentaires, y compris les frais de transport, un remplacement pour tout produit vendu par SKF et trouvé défectueux par SKF, contrairement à cette garantie limitée, et (B) dans le cas d'un produit qui ne peut être réparé ou remplacé par SKF, SKF offrira à l'acheteur un crédit ou un remboursement du prix d'achat payé pour le produit, à condition que SKF ait été avisée par écrit de la non-conformité de tout produit dans les trente (30) jours suivant la date de la découverte de ces défauts, et le produit non conforme doit être retourné FOB à l'entrepôt désigné par SKF dans les plus brefs délais, mais en aucun cas après l'expiration de la période de garantie applicable au produit, comme suit : (1) Les produits (à l'exception des moyeux à service léger et des kits de courroies de distribution) sont garantis par SKF pendant une durée de douze (12) mois suivant la date d'achat; (2) les moyeux de roulement de roues à service léger sont garantis pendant une durée de soixante (60) mois suivant la date d'achat, ou 60 000 miles (100 000 kilomètres), la date la plus rapprochée prévalant; (3) les kits de courroies de distribution sont garantis pendant une durée de vingt-quatre (24) mois suivant la date d'achat, ou 30 000 miles (48 000 kilomètres), la date la plus rapprochée prévalant; et (4) les joints en U font l'objet d'une garantie à vie limitée. Preuve d'achat/de kilométrage valide obligatoire. En aucun cas, SKF ne sera tenue responsable, en vertu de cette garantie ou autrement, d'une usure normale, ou de tout produit vendu par SKF qui, après livraison par SKF et à l'entière discrétion de SKF, a été soumis à un accident, un abus, une mauvaise application, une réparation ou une installation incorrecte ou défectueuse, un entretien ou une lubrification inadéquate ou défectueuse, une modification ou une négligence, un chargement excessif ou d'autres conditions d'utilisation excessives, ou des défauts causés par ou résultant de spécifications ou de conceptions de l'acheteur ou autrement causés par l'acheteur. DANS TOUTE LA MESURE PERMISE PAR LA LOI APPLICABLE, SKF REJETTE LA RESPONSABILITÉ DÉLICTEUELLE OU CONTRACTUELLE, PAR NÉGLIGENCE, RESPONSABILITÉ STRICTE OU AUTRE, POUR TOUT AUTRE RECOURS OU DOMMAGE, DIRECT OU INDIRECT, ACCESSOIRE, SPECIAL, EXEMPLAIRE OU CONSÉCUTIF EN RAPPORT AVEC SA PERFORMANCE EN VERTU DES PRÉSENTES, Y COMPRIS ET SANS S'Y LIMITER, LES PRODUITS VENDUS OU FOURNIS CI-DESSOUS PAR SKF, ET SA PRESTATION DE TOUT SERVICE ASSOCIÉ. CETTE GARANTIE LIMITÉE EXCLUT TOUTE AUTRE GARANTIE, EXPLICITE OU IMPLICITE, Y COMPRIS LES GARANTIES DE QUALITÉ MARCHANDE OU D'ADAPTATION À UN USAGE PARTICULIER. LES FRAIS D'ENTRETIEN DE ROUTINE NE SONT PAS COUVERTS PAR CETTE GARANTIE LIMITÉE. Sans limiter la portée générale des dispositions précédentes, SKF nie toute responsabilité envers l'acheteur pour toute perte, tout coût ou dommage subi à la suite d'un temps d'arrêt, ou toute perte d'usage ou de disponibilité du lieu de travail, toute perte de revenus ou de profits, même si SKF a été avertie de la possibilité de tels dommages ou pertes et a, ou aurait pu, anticiper lesdits dommages ou pertes. Aucune autre personne n'est autorisée par SKF à entériner ou faire, au nom de SKF, toute autre déclaration ou garantie autre que ou contraire à la présente garantie limitée ou contraire aux limitations et avis de non-responsabilité qui figurent aux présentes. Les recours exclusifs offerts dans cette garantie limitée ne doivent pas être considérés comme ayant échoué de leur but essentiel aussi longtemps que SKF est désireuse et capable de les réaliser dans la mesure et selon les modalités prévues dans la présente garantie.

Cette garantie limitée vous donne des droits juridiques particuliers, et vous pourriez aussi avoir d'autres droits, qui peuvent varier d'un État à l'autre.

CERTAINS ÉTATS N'AUTORISENT PAS LES LIMITATIONS CONCERNANT LA DURÉE D'UNE GARANTIE IMPLICITE OU L'EXCLUSION OU LA LIMITATION DES DOMMAGES ACCESSOIRES OU CONSÉCUTIFS; LES EXCLUSIONS ET LES LIMITATIONS CI-DESSUS PEUVENT NE PAS S'APPLIQUER À VOUS. Cette garantie limitée vous donne des droits juridiques particuliers, et vous pourriez aussi avoir d'autres droits, qui peuvent varier d'un État à l'autre.

INFORMATION ET RETOURS : Ce catalogue fait référence à des produits conçus avant sa publication, et ne couvre pas les modifications de produits effectuées après sa date de publication. Les questions peuvent être adressées à : SKF Customer Service Department, 890 North State Street, Suite 200, Elgin, IL 60123, ou composez le 1 800 882-0008. Toute erreur d'envoi (concernant des envois de volumes de produits supérieurs ou de produits ne correspondant pas à la description donnée à l'acheteur lors de la commande) peut faire l'objet d'un retour en échange d'un crédit ou d'un remplacement par SKF, à condition que SKF soit avisée par écrit par l'acheteur d'une telle non-conformité dans les 30 jours suivant la livraison du produit à l'acheteur, et seulement après que SKF ait donné une autorisation écrite. Les retours autorisés doivent être expédiés port payé et arriver en bon état commercialisable afin d'obtenir un crédit ou un remplacement. SKF n'est autrement pas obligé d'accepter le retour de tout produit qu'elle a vendu ou

AVIS: Les systèmes de numérotation des pièces SKF sont la propriété de SKF. Toute utilisation abusive ou non autorisée de ces systèmes de numérotation, y compris l'adoption ou l'utilisation de l'un de ces numéros de pièce ou des listes de numéros de pièces, même si ces produits font l'objet de modifications ou d'ajouts, est strictement interdite et sera poursuivie par SKF comme une violation des lois sur les droits d'auteur, les marques et sur la concurrence déloyale aux États-Unis et à l'étranger. En outre, l'utilisation d'une marque de commerce, d'un nom commercial ou d'un système d'emballage de SKF, des systèmes, couleurs ou dessins de SKF est également considérée comme une violation des droits des marques de commerce, noms commerciaux et identités du commerce de SKF USA Inc et de ses sociétés affiliées. Toute violation potentielle d'une telle utilisation devrait être portée à l'attention de SKF : SKF USA Inc., 890 Forty Foot Road, Lansdale,



WARNING!

Proper selection of the products listed for sale in this catalog is essential to minimize the risk of any seal, bearing or other product failure. Such failures can result in property damage or severe personal injury to operators of machinery, vehicles or to others. You must carefully evaluate the particular application on or into which you intend to install the products. Products in this catalog require installation by an experienced professional mechanic or qualified maintenance professional.

The product properties and operating parameters described in this catalogue are based upon tests conducted by SKF or reported by others. SKF does not assume any responsibility for errors in the data published in this catalog. The life and performance of the products ultimately depend on a number of factors. These include, for example, selection of product design type, selection of materials for their different properties, handling and installation, operating conditions, including shaft surface or bore conditions, the quantity, quality and chemistry of lubricants and other factors. Severe environments can adversely affect product life or performance. For help in realizing longer SKF product life, and optimal performance for your specific application, contact SKF's Customer Services Department at 1-800-882-0008.

LIMITED WARRANTY

SKF warrants to the first purchaser that the products sold by it, when properly installed, will be free from defects in material and workmanship. SKF's sole obligation and liability for any defect found to exist contrary to this limited warranty in a product sold by SKF, and purchaser's sole and exclusive remedy for such defect, shall be limited to: (A) SKF furnishing without additional charge to purchaser, including transportation, a replacement for any of the products sold by SKF which are found by SKF to be defective contrary to this limited warranty, and (B) in the case of products which cannot be repaired or replaced by SKF, SKF shall credit or refund to purchaser the purchase price paid therefore; provided, that SKF must be advised in writing of any product non-conformance within thirty (30) days of the date of the discovery thereof, and the non-conforming product must be returned f.o.b. to SKF's designated warehouse promptly, but in no event after the expiration of the warranty period applicable to the product as follows: (1) Products (light duty hub units and timing chain kits excepted) are warranted by SKF for a period of twelve (12) months from the date of purchase; (2) light duty hub bearing units are warranted for a period of sixty (60) months from the date of purchase, or 60,000 miles (100,000 kilometers), whichever occurs first; (3) timing chain kits are warranted for a period of twenty-four (24) months from the date of purchase, or 30,000 miles (48,000 kilometers), whichever occurs first; and (4) U-Joints are subject to a limited lifetime warranty. Valid proof of purchase date/mileage required. In no event shall SKF be obligated under this limited warranty or otherwise in any way whatsoever for normal wear and tear, or for any products sold by SKF which, after delivery by SKF and in SKF's sole determination, have been subjected to accident, abuse, misapplication, improper or faulty repair or installation, improper or faulty maintenance or lubrication, any alteration or neglect, excessive loading or other excessive operating conditions, or for defects caused by or resulting from purchaser's specifications or designs or otherwise caused by purchaser. TO THE FURTHEST EXTENT PERMITTED UNDER APPLICABLE LAW, SKF DISCLAIMS LIABILITY, IN TORT OR CONTRACT, IN NEGLIGENCE, STRICT LIABILITY, OR OTHERWISE, FOR ANY OTHER REMEDY OR DAMAGE, WHETHER DIRECT OR INDIRECT, INCIDENTAL, SPECIAL, EXEMPLARY, OR CONSEQUENTIAL WITH RESPECT TO ITS PERFORMANCE HEREUNDER, INCLUDING WITHOUT LIMITATION THE PRODUCTS SOLD OR PROVIDED HEREUNDER BY SKF, AND ITS PROVISION OF ANY RELATED SERVICES. THIS LIMITED WARRANTY IS TO THE EXCLUSION OF ALL OTHER WARRANTIES, EXPRESS OR IMPLIED, INCLUDING WARRANTIES OF MERCHANTABILITY OR FITNESS FOR A PARTICULAR PURPOSE. COSTS INCURRED FOR ROUTINE MAINTENANCE ARE NOT COVERED BY THIS LIMITED WARRANTY. Without limiting the generality of the foregoing, SKF specifically disclaims liability to purchaser for any loss, cost, or damage incurred as a result of equipment downtime, or loss of use or availability of worksite, lost revenues or lost profits, regardless of whether SKF is on notice of the possibility of such damage or loss and did or could have anticipated same. No other person has been authorized by SKF to undertake or make on behalf of SKF any further representation, warranty or guarantee in addition to or contrary to this limited warranty or contrary to the limitations and disclaimers provided herein. The exclusive remedies provided in this limited warranty shall not be deemed to have failed of their essential purpose so long as SKF is willing and able to perform to the extent and in the manner prescribed in this limited warranty.

SOME STATES DO NOT ALLOW LIMITATIONS ON HOW LONG AN IMPLIED WARRANTY LASTS OR THE EXCLUSION OR LIMITATION OF INCIDENTAL OR CONSEQUENTIAL DAMAGES, SO THE ABOVE EXCLUSIONS OR LIMITATIONS MAY NOT APPLY TO YOU. This limited warranty gives you specific legal rights, and you may also have other rights, which vary state to state.

INFORMATION AND RETURNS: This catalog refers to products as designed prior to its publication, and does not cover product changes made after its publication date. Inquiries can be directed to: SKF Customer Service Department, 890 North State Street, Suite 200, Elgin, IL 60123, or call 1-800-882-0008. Any error in shipment (for over-shipments in the quantity of product or for product not matching purchaser's description given in its order) is returnable for credit or replacement by SKF, provided that SKF is advised in writing by purchaser of such non-conformance within 30 days after the product's delivery to purchaser, and only after written authorization therefore is given by SKF. Approved returns must be shipped freight prepaid and arrive in good, saleable condition to qualify for credit or replacement. SKF shall not otherwise be obligated to accept the return of any products sold or distributed by it.

NOTICE: The SKF part numbering systems for the SKF products are proprietary to SKF. Any improper or unauthorized use of these numbering systems, including adoption or use of any of their part numbers or part number lists, even where the subject of modification or addition, is strictly prohibited and will be prosecuted by SKF as a violation of U.S. and foreign copyright, trademark and unfair competition laws. In addition, use of any SKF trademarks, trade names or packaging schemes, systems, colors or designs is likewise considered a violation of the trademarks, trade names and trade identities rights of SKF USA Inc. and their affiliates. Possible violation of such use should be brought to the attention of SKF: SKF USA Inc., 890 Forty Foot Road, Lansdale, PA 19446, Attn: Catalog Manager.

**RWD Passenger Car
Application Section**

Passenger cars, light & medium trucks

Alfa Romeo Berlina, Giulia, Giulietta, Spider Veloce

MFG./YEAR	MODEL & LOCATION	PART NO.	MFG./YEAR	MODEL & LOCATION	PART NO.
-----------	------------------	----------	-----------	------------------	----------

Drive Shaft

U-Joint

1994-1954 All: [Type 6]

U-Joint (Center) ①UJ413
 U-Joint (Rear) ②UJ413

American Motors Ambassador

Drive Shaft

U-Joint

1974-1967 All: [Type 1]

U-Joint (Front) ①UJ369
Brute Force GreaseableUJ280
Brute Force Non GreaseableUJ269
 (For Aluminum Drive Shaft)UJ369C
 U-Bolt Kit (Front)UJ329-10
 U-Joint (Rear) ②UJ369
Brute Force GreaseableUJ280
Brute Force Non GreaseableUJ269
 (For Aluminum Drive Shaft)UJ369C
 U-Bolt Kit (Rear)UJ329-10

1966-1963 All: [Type 4]

U-Joint (Front) ①UJ515
 1962-1960 Auto. Trans. & 1.016" Dia. Brg. Cup:
 [Type 4]
 U-Joint (Front) ①UJ507

Drive Shaft (Cont.)

U-Joint (Cont.)

1962-1960 Auto. Trans. & 1.125" Dia. Brg. Cup:
 [Type 4]

U-Joint (Front) ①UJ513
 1962-1960 Man. Trans.: [Type 4]
 U-Joint (Front) ①UJ513
 1959-1958 All: [Type 4]
 U-Joint (Front) ①UJ513

American Motors American, AMX ([1968] thru [1974]), Javelin

Drive Shaft

U-Joint

1974-1968 AMX & Javelin: [Type 1]

U-Joint (Front) ①UJ369
Brute Force GreaseableUJ280
Brute Force Non GreaseableUJ269
 (For Aluminum Drive Shaft)UJ369C
 U-Bolt Kit (Front)UJ329-10
 U-Joint (Rear) ②UJ369
Brute Force GreaseableUJ280
Brute Force Non GreaseableUJ269
 (For Aluminum Drive Shaft)UJ369C
 U-Bolt Kit (Rear)UJ329-10

1968 American: [Type 1]

U-Joint (Front) ①UJ369
Brute Force GreaseableUJ280
Brute Force Non GreaseableUJ269
 (For Aluminum Drive Shaft)UJ369C
 U-Bolt Kit (Front)UJ329-10
 U-Joint (Rear) ②UJ369
Brute Force GreaseableUJ280
Brute Force Non GreaseableUJ269
 (For Aluminum Drive Shaft)UJ369C
 U-Bolt Kit (Rear)UJ329-10

Drive Shaft (Cont.)

U-Joint (Cont.)

1967 American w/ Auto Trans.: [Type 1]

U-Joint (Front) ①UJ507
 U-Joint (Rear) ②UJ498
 1967 American w/ Man. Trans.: [Type 1]
 U-Joint (Front) ①UJ498
 U-Joint (Rear) ②UJ498

1966-1965 American w/ 3.2L & 3.3L Engs.:

[Type 1]

U-Joint (Front) ①UJ514G
 U-Joint (Rear) ②UJ514G

1966-1965 American w/ 3.8L & 4.7L Engs.:

[Type 1]

U-Joint (Front) ①UJ507
 U-Joint (Rear) ②UJ498





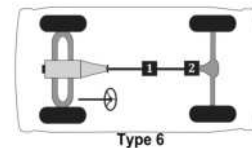
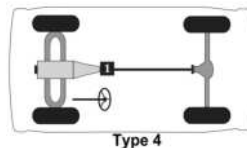
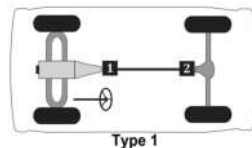















1964 American: [Type 1]

U-Joint (Front) ①UJ514G
 U-Joint (Rear) ②UJ514G



Passenger cars, light & medium trucks

American Motors AMX ([1978]-[1980]), Concord, Gremlin, Hornet, Pacer, Spirit

MFG./YEAR	MODEL & LOCATION	PART NO.	MFG./YEAR	MODEL & LOCATION	PART NO.
Drive Shaft			Drive Shaft (Cont.)		
U-Joint			U-Joint (Cont.)		
1982-1979 4 & 6 Cyl. Engs. w/ Inner Lock Ring:			1975 6 Cyl Eng. w/ 2.6875" Yoke: [Type 1]		
[Type 1]					
	U-Joint (Front) 	UJ315G		U-Joint (Front) 	UJ437G
	Brute Force Greaseable	UJ246		Brute Force Greaseable	UJ240
	Clamp Kit (Front)	UJ318-10		Brute Force Non Greaseable	UJ237
	U-Joint (Rear) 	UJ315G		Clamp Kit (Front)	UJ437-10
	Brute Force Greaseable	UJ246		U-Joint (Rear) 	UJ437G
	Clamp Kit (Rear)	UJ318-10		Brute Force Greaseable	UJ240
				Brute Force Non Greaseable	UJ237
				Clamp Kit (Rear)	UJ437-10
1982-1979 4 & 6 Cyl. Engs. w/ Outer Lock Ring:			1975 V8 Eng. w/ Outer Lock Ring: [Type 1]		
[Type 1]					
	U-Joint (Front) 	UJ369		U-Joint (Front) 	UJ369
	Brute Force Greaseable	UJ280		Brute Force Greaseable	UJ280
	Brute Force Non Greaseable	UJ269		Brute Force Non Greaseable	UJ269
	(For Aluminum Drive Shaft)	UJ369C		(For Aluminum Drive Shaft)	UJ369C
	U-Bolt Kit (Front)	UJ329-10		U-Bolt Kit (Front)	UJ329-10
				U-Joint (Rear) 	UJ369
1978-1976 V8 Eng.: [Type 1]					
[Type 1]					
	U-Joint (Front) 	UJ315G		Brute Force Greaseable	UJ280
	Brute Force Greaseable	UJ246		Brute Force Non Greaseable	UJ269
	Clamp Kit (Front)	UJ318-10		(For Aluminum Drive Shaft)	UJ369C
	U-Joint (Rear) 	UJ315G		U-Bolt Kit (Rear)	UJ329-10
	Brute Force Greaseable	UJ246			
	Clamp Kit (Rear)	UJ318-10			
1978-1976 4 & 6 Cyl. Engs. w/ Inner Lock Ring:			1975 6 Cyl Eng. w/ 3.5" Yoke: [Type 1]		
[Type 1]					
	U-Joint (Front) 	UJ315G		U-Joint (Front) 	UJ369
	Brute Force Greaseable	UJ246		Brute Force Greaseable	UJ280
	Clamp Kit (Front)	UJ318-10		Brute Force Non Greaseable	UJ269
	U-Joint (Rear) 	UJ315G		(For Aluminum Drive Shaft)	UJ369C
	Brute Force Greaseable	UJ246		U-Bolt Kit (Front)	UJ329-10
	Clamp Kit (Rear)	UJ318-10		U-Joint (Rear) 	UJ369
1978-1976 4 & 6 Cyl. Engs. w/ Outer Lock Ring:					
[Type 1]					
	U-Joint (Front) 	UJ369		Brute Force Greaseable	UJ280
	Brute Force Greaseable	UJ280		Brute Force Non Greaseable	UJ269
	Brute Force Non Greaseable	UJ269		(For Aluminum Drive Shaft)	UJ369C
	(For Aluminum Drive Shaft)	UJ369C		U-Bolt Kit (Front)	UJ329-10
	U-Bolt Kit (Front)	UJ329-10		U-Joint (Rear) 	UJ369
	U-Joint (Rear) 	UJ369		Brute Force Greaseable	UJ280
	Brute Force Greaseable	UJ280		Brute Force Non Greaseable	UJ269
	Brute Force Non Greaseable	UJ269		(For Aluminum Drive Shaft)	UJ369C
	(For Aluminum Drive Shaft)	UJ369C		U-Bolt Kit (Rear)	UJ329-10
	U-Bolt Kit (Rear)	UJ329-10			
1975 V8 Eng. w/ Inner Lock Ring: [Type 1]			1974-1970 Gremlin & Hornet: [Type 1]		
[Type 1]					
	U-Joint (Front) 	UJ315G		U-Joint (Front) 	UJ369
	Brute Force Greaseable	UJ246		Brute Force Greaseable	UJ280
	Clamp Kit (Front)	UJ318-10		Brute Force Non Greaseable	UJ269
	U-Joint (Rear) 	UJ315G		(For Aluminum Drive Shaft)	UJ369C
	Brute Force Greaseable	UJ246		U-Bolt Kit (Front)	UJ329-10
	Clamp Kit (Rear)	UJ318-10		U-Joint (Rear) 	UJ369

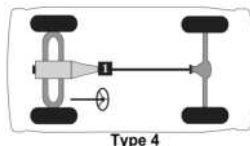
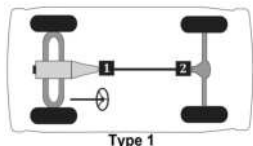

Passenger cars, light & medium trucks

American Motors Classic, Marlin, Rambler

MFG./YEAR	MODEL & LOCATION	PART NO.	MFG./YEAR	MODEL & LOCATION	PART NO.
Drive Shaft			Drive Shaft (Cont.)		
U-Joint			U-Joint (Cont.)		
1969	Rambler: [Type 1]		1965	Classic w/ 3.2L & 3.3L Eng.: [Type 4]	
	U-Joint (Front) ①	UJ369		U-Joint (Front) ①	UJ514G
	Brute Force Greaseable	UJ280	1965	Classic w/ 3.8L Eng.: [Type 4]	
	Brute Force Non Greaseable	UJ269		U-Joint (Front) ①	UJ515
	(For Aluminum Drive Shaft)	UJ369C	1965-1963	Classic & Marlin w/ V8 Eng.: [Type 4]	
	U-Bolt Kit (Front)	UJ329-10		U-Joint (Front) ①	UJ515
	U-Joint (Rear) ②	UJ369	1964	Classic w/ 6 Cyl. Eng.: [Type 4]	
	Brute Force Greaseable	UJ280		U-Joint (Front) ①	UJ514G
	Brute Force Non Greaseable	UJ269	1963	Classic w/ 6 Cyl. Eng.: [Type 4]	
	(For Aluminum Drive Shaft)	UJ369C		U-Joint (Front) ①	UJ341
	U-Bolt Kit (Rear)	UJ329-10			
1967	Marlin: [Type 1]				
	U-Joint (Front) ①	UJ369			
	Brute Force Greaseable	UJ280			
	Brute Force Non Greaseable	UJ269			
	(For Aluminum Drive Shaft)	UJ369C			
	U-Bolt Kit (Front)	UJ329-10			
	U-Joint (Rear) ②	UJ369			
	Brute Force Greaseable	UJ280			
	Brute Force Non Greaseable	UJ269			
	(For Aluminum Drive Shaft)	UJ369C			
	U-Bolt Kit (Rear)	UJ329-10			
1966	Classic & Marlin: [Type 4]				
	U-Joint (Front) ①	UJ515			

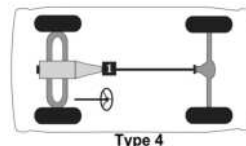
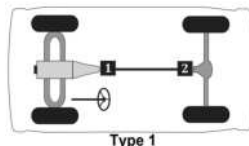

American Motors Eagle

MFG./YEAR	MODEL & LOCATION	PART NO.	MFG./YEAR	MODEL & LOCATION	PART NO.
Drive Shaft			Drive Shaft (Cont.)		
U-Joint			U-Joint (Cont.)		
1988-1982 All: [Type 13]			1981-1980 6 Cyl. Eng. w/ Inner Lock Rings:		
			[Type 13]		
	U-Joint (Frnt. Shaft; Frnt.) ①	UJ369		U-Joint (Frnt. Shaft; Frnt.) ①	UJ369
	<i>Brute Force Greaseable</i>	UJ280		<i>Brute Force Greaseable</i>	UJ280
	<i>Brute Force Non Greaseable</i>	UJ269		<i>Brute Force Non Greaseable</i>	UJ269
	(For Aluminum Drive Shaft)	UJ369C		(For Aluminum Drive Shaft)	UJ369C
	Clamp Kit (Frnt. Shaft; Frnt.)	UJ437-10		Clamp Kit (Frnt. Shaft; Frnt.)	UJ437-10
	U-Joint (Frnt. Shaft; Rr.) ②	UJ369		U-Joint (Frnt. Shaft; Rr.) ②	UJ369
	<i>Brute Force Greaseable</i>	UJ280		<i>Brute Force Greaseable</i>	UJ280
	<i>Brute Force Non Greaseable</i>	UJ269		<i>Brute Force Non Greaseable</i>	UJ269
	(For Aluminum Drive Shaft)	UJ369C		(For Aluminum Drive Shaft)	UJ369C
	Clamp Kit (Frnt. Shaft; Rr.)	UJ437-10		Clamp Kit (Frnt. Shaft; Rr.)	UJ437-10
	U-Joint (Rr. Shaft; Frnt.) ③	UJ369		U-Joint (Rr. Shaft; Frnt.) ③	UJ315G
	<i>Brute Force Greaseable</i>	UJ280		<i>Brute Force Greaseable</i>	UJ246
	<i>Brute Force Non Greaseable</i>	UJ269		<i>Brute Force Non Greaseable</i>	UJ269
	(For Aluminum Drive Shaft)	UJ369C		(For Aluminum Drive Shaft)	UJ369C
	Clamp Kit (Rr. Shaft; Frnt.)	UJ437-10		Clamp Kit (Rr. Shaft; Frnt.)	UJ318-10
	U-Joint (Rr. Shaft; Rr.) ④	UJ369		U-Joint (Rr. Shaft; Rr.) ④	UJ315G
	<i>Brute Force Greaseable</i>	UJ280		<i>Brute Force Greaseable</i>	UJ246
	<i>Brute Force Non Greaseable</i>	UJ269		<i>Brute Force Non Greaseable</i>	UJ269
	(For Aluminum Drive Shaft)	UJ369C		(For Aluminum Drive Shaft)	UJ318-10
	Clamp Kit (Rr. Shaft; Rr.)	UJ437-10		Clamp Kit (Rr. Shaft; Rr.)	UJ318-10
	1981 4 Cyl. Eng. w/ Inner Lock Rings:			1981-1980 6 Cyl. Eng. w/ Outer Lock Rings:	
	[Type 15]			[Type 13]	
	U-Joint (Frnt. Shaft; Frnt.) ①	UJ341		U-Joint (Frnt. Shaft; Frnt.) ①	UJ369
	U-Joint (Rr. Shaft; Frnt.) ②	UJ315G		<i>Brute Force Greaseable</i>	UJ280
	<i>Brute Force Greaseable</i>	UJ246		<i>Brute Force Non Greaseable</i>	UJ269
	Clamp Kit (Rr. Shaft; Frnt.)	UJ318-10		(For Aluminum Drive Shaft)	UJ369C
	U-Joint (Rr. Shaft; Rr.) ③	UJ315G		Clamp Kit (Frnt. Shaft; Frnt.)	UJ437-10
	<i>Brute Force Greaseable</i>	UJ246		U-Joint (Frnt. Shaft; Rr.) ②	UJ369
	Clamp Kit (Rr. Shaft; Rr.)	UJ318-10		<i>Brute Force Greaseable</i>	UJ280
	1981 4 Cyl. Eng. w/ Outer Lock Rings:			<i>Brute Force Non Greaseable</i>	UJ269
	[Type 15]			(For Aluminum Drive Shaft)	UJ369C
	U-Joint (Frnt. Shaft; Frnt.) ①	UJ341		Clamp Kit (Frnt. Shaft; Rr.)	UJ437-10
	U-Joint (Rr. Shaft; Frnt.) ②	UJ369		U-Joint (Rr. Shaft; Frnt.) ③	UJ369
	<i>Brute Force Greaseable</i>	UJ280		<i>Brute Force Greaseable</i>	UJ280
	<i>Brute Force Non Greaseable</i>	UJ269		<i>Brute Force Non Greaseable</i>	UJ269
	(For Aluminum Drive Shaft)	UJ369C		(For Aluminum Drive Shaft)	UJ369C
	Clamp Kit (Rr. Shaft; Frnt.)	UJ437-10		Clamp Kit (Rr. Shaft; Frnt.)	UJ437-10
	U-Joint (Rr. Shaft; Rr.) ③	UJ319		U-Joint (Rr. Shaft; Rr.) ④	UJ319
	Clamp Kit (Rr. Shaft; Rr.)	UJ318-10			

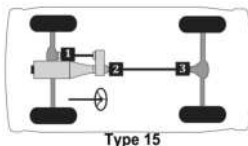
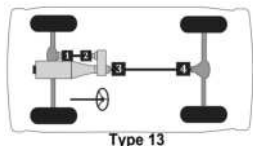

4 ▲ For Use w/ 1.063" Bearing Cap Application. ○ For Use w/ 1.188" Bearing Cap Application. ◇ For Use w/ Inner Lock Ring Application on Half Shaft. □ For Use w/ Outer Lock Ring Application on Half Shaft.

Passenger cars, light & medium trucks

American Motors Matador, Rebel

MFG./YEAR	MODEL & LOCATION	PART NO.	MFG./YEAR	MODEL & LOCATION	PART NO.
Drive Shaft			Drive Shaft (Cont.)		
U-Joint			U-Joint (Cont.)		
1978-1976 6 Cyl. Eng. w/ Inner Lock Rings:			1975 w/ Outer Lock Rings: [Type 1]		
[Type 1]			U-Joint (Front) ① UJ369		
U-Joint (Front) ① UJ315G			Brute Force Greaseable UJ280		
Brute Force Greaseable UJ246			Brute Force Non Greaseable UJ269		
Clamp Kit (Front) UJ318-10			(For Aluminum Drive Shaft) UJ369C		
U-Joint (Rear) ② UJ315G			U-Bolt Kit (Front) UJ329-10		
Brute Force Greaseable UJ246			U-Joint (Rear) ② UJ369		
Clamp Kit (Rear) UJ318-10			Brute Force Greaseable UJ280		
1978-1976 V8 Eng.: [Type 1]			Brute Force Non Greaseable UJ269		
U-Joint (Front) ① UJ315G			(For Aluminum Drive Shaft) UJ369C		
Brute Force Greaseable UJ246			U-Bolt Kit (Rear) UJ329-10		
Clamp Kit (Front) UJ318-10			1974-1967 All: [Type 1]		
U-Joint (Rear) ② UJ315G			U-Joint (Front) ① UJ369		
Brute Force Greaseable UJ246			Brute Force Greaseable UJ280		
Clamp Kit (Rear) UJ318-10			Brute Force Non Greaseable UJ269		
1978-1976 6 Cyl. Eng. w/ Outer Lock Rings:			(For Aluminum Drive Shaft) UJ369C		
[Type 1]			U-Bolt Kit (Front) UJ329-10		
U-Joint (Front) ① UJ369			U-Joint (Rear) ② UJ369		
Brute Force Greaseable UJ280			Brute Force Greaseable UJ280		
Brute Force Non Greaseable UJ269			Brute Force Non Greaseable UJ269		
(For Aluminum Drive Shaft) UJ369C			(For Aluminum Drive Shaft) UJ369C		
U-Bolt Kit (Front) UJ329-10			U-Bolt Kit (Rear) UJ329-10		
U-Joint (Rear) ② UJ369			1966 All: [Type 4]		
Brute Force Greaseable UJ280			U-Joint (Front) ① UJ515		
Brute Force Non Greaseable UJ269					
(For Aluminum Drive Shaft) UJ369C					
U-Bolt Kit (Rear) UJ329-10					
1975 w/ Inner Lock Rings: [Type 1]					
U-Joint (Front) ① UJ315G					
Brute Force Greaseable UJ246					
Clamp Kit (Front) UJ318-10					
U-Joint (Rear) ② UJ315G					
Brute Force Greaseable UJ246					
Clamp Kit (Rear) UJ318-10					

Audi

Drive Shaft	
U-Joint	
2007-2006 A3:	
Flex CouplerVKJF98040
2006-2000 TT Quattro:	
Flex CouplerVKJF98040

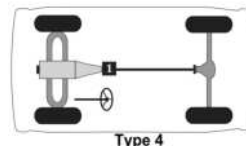
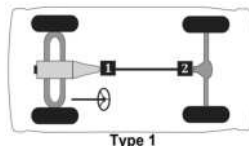

Passenger cars, light & medium trucks

Austin America, Marina

MFG./YEAR	MODEL & LOCATION	PART NO.	MFG./YEAR	MODEL & LOCATION	PART NO.
Drive Shaft					
U-Joint					
1975-1973 Marina w/ Outer Lock Rings: [Type 1]					
	U-Joint (Front)Ⓛ	UJ341			
	U-Joint (Rear)Ⓢ	UJ341			
1971-1968 America: [Type 11]					
	U-Joint (Rear Half Shaft)Ⓛ	[2] UJ341			

Austin-Healey Sprite, 100-6, 3000

Drive Shaft					
U-Joint					
1970-1958 Sprite: [Type 1]					
	U-Joint (Front)Ⓛ	UJ341			
	U-Joint (Rear)Ⓢ	UJ341			
1967-1956 100-6 & 3000: [Type 1]					
	U-Joint (Front)Ⓛ	UJ344			
	U-Joint (Rear)Ⓢ	UJ344			

BMW

Drive Shaft					
U-Joint					
2021-2017 530iX & 540iX:					
	Flex Coupler	VKJF98004			
2019-2018 640iX:					
	Flex Coupler	VKJF98004			
2019-2017 440ix:					
	Flex Coupler	VKJF98004			
2019-2017 740iX:					
	Flex Coupler	VKJF98004			
2018-2017 230i & 430i:					
	Flex Coupler	VKJF98004			
2018-2016 330e:					
	Flex Coupler	VKJF98004			
2018-2014 328d:					
	Flex Coupler	VKJF98004			
2018-2013 320i:					
	Flex Coupler	VKJF98001			
2016-2015 M235xi:					
	Flex Coupler	VKJF98004			
2016-2014 228i, 328i, 428i, 435i & 528i:					
	Flex Coupler	VKJF98004			
2016-2014 Z4:					
	Flex Coupler	VKJF98004			
2016-2012 M5 w/ 4.4L Eng.:					
	Flex Coupler	VKJF98008			
2016-2011 550i w/ F10 & F07:					
	Flex Coupler	VKJF98012			
2014-2012 528i xDrive:					
	Flex Coupler	VKJF98003			
2013-2009 328i xDrive w/ E90 & E91:					
	Flex Coupler	VKJF98008			
2013-2008 M3 w/ E92 & E93:					
	Flex Coupler	VKJF98011			

Drive Shaft (Cont.)					
U-Joint (Cont.)					
2012-2011 535i GT xDrive & 550i xDrive:					
	Flex Coupler	VKJF98010			
2012-2010 750i xDrive & 750Li xDrive:					
	Flex Coupler	VKJF98010			
2012-2009 335i:					
	Flex Coupler	VKJF98009			
2012-2009 528i & 535i:					
	Flex Coupler	VKJF98009			
2011 528i w/F10					
	Flex Coupler	VKJF98008			
2010-2008 135i:					
	Flex Coupler	VKJF98010			
2010-2007 M6 w/ E63 & E64:					
	Flex Coupler	VKJF98011			
2010-2006 M5 w/ E60 & E64:					
	Flex Coupler	VKJF98011			
2008 528xi & 535xi:					
	Flex Coupler	VKJF98009			
2008-2007 328Xi & 335Xi w/ AWD:					
	Flex Coupler	VKJF98009			
2008-2006 Z4:					
	Flex Coupler	VKJF98005			
2007-2006 525Xi:					
	Flex Coupler	VKJF98009			
2006 325xi, 330i & 330xi w/ E90 & E91:					
	Flex Coupler	VKJF98008			
2006-2001 M3:					
	Flex Coupler	VKJF98005			
2006-2001 325Ci:					
	Flex Coupler	VKJF98001			
					(Continued)

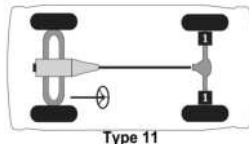
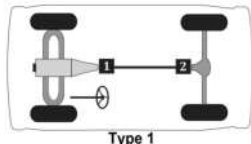

Passenger cars, light & medium trucks

(Cont.) -- BMW

MFG./YEAR	MODEL & LOCATION	PART NO.	MFG./YEAR	MODEL & LOCATION	PART NO.
Drive Shaft (Cont.)			Drive Shaft (Cont.)		
U-Joint (Cont.)			U-Joint (Cont.)		
2005	645Ci w/ E64 & E63:		1995-1992	325i:	
	Flex Coupler	VKJF98012		Flex Coupler	VKJF98001
2005	545i:		1995-1992	525i:	
	Flex Coupler	VKJF98012		Flex Coupler	VKJF98001
2005-2003	Z4 w/ 2.5L Eng.:		1994-1988	750iL: [Type 1]	
	Flex Coupler	VKJF98001		U-Joint (Front)⓪	UJ10431
2005-2001	325Xi & 330Xi:			U-Joint (Rear)⓪	UJ10431
	Flex Coupler	VKJF98003	1993	525it:	
2005-2001	325i:			Flex Coupler	VKJF98001
	Flex Coupler	VKJF98001	1993-1991	M5: [Type 1]	
2003-2001	525i:			U-Joint (Front)⓪	UJ10431
	Flex Coupler	VKJF98001		U-Joint (Rear)⓪	UJ10431
2003-2000	M5:		1993-1991	M5:	
	Flex Coupler	VKJF98002		Flex Coupler	VKJF98005
2002-1998	Z3:		1993-1989	535i: [Type 1]	
	Flex Coupler	VKJF98005		U-Joint (Front)⓪	UJ10431
2001-1997	740i:			U-Joint (Rear)⓪	UJ10431
	Flex Coupler	VKJF98002	1992-1987	735i: [Type 1]	
2000-1998	323i:			U-Joint (Front)⓪	UJ10431
	Flex Coupler	VKJF98001		U-Joint (Rear)⓪	UJ10431
2000-1997	540i:				
	Flex Coupler	VKJF98002			
2000-1996	740iL:				
	Flex Coupler	VKJF98002			
1999-1998	323is:				
	Flex Coupler	VKJF98001			
1999-1995	M3:				
	Flex Coupler	VKJF98005			
1999-1995	318i:				
	Flex Coupler	VKJF98001			
1997-1996	840Ci:				
	Flex Coupler	VKJF98002			

BMW CUV X1, X2, X3, X4, X5, X6

Drive Shaft			Drive Shaft (Cont.)		
U-Joint			U-Joint (Cont.)		
2020-2018	X2:		2010-2008	X6:	
	Flex Coupler	VKJF98001		Flex Coupler	VKJF98007
2020-2016	X1:		2010-2000	X5:	
	Flex Coupler	VKJF98001		Flex Coupler	VKJF98007
2018-2015	X4:		2006-2004	X3:	
	Flex Coupler	VKJF98004		Flex Coupler	VKJF98003
2018-2014	X5 & X6:				
	Flex Coupler	VKJF98004			
2017-2014	X3:				
	Flex Coupler	VKJF98004			
2015-2014	X1:				
	Flex Coupler	VKJF98004			
2015-2013	X1 sDrive28i w/ E84:				
	Flex Coupler	VKJF98008			
2013-2008	X6:				
	Flex Coupler	VKJF98003			
2013-2000	X5:				
	Flex Coupler	VKJF98003			

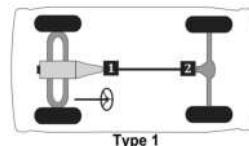

Passenger cars, light & medium trucks

Buick (RWD) Centurion, Electra (thru [1984]), Estate Wagon, Invicta, LeSabre (thru [1985]), Riviera (thru 1978), Roadmaster, Wildcat

MFG./YEAR	MODEL & LOCATION	PART NO.	MFG./YEAR	MODEL & LOCATION	PART NO.
Drive Shaft			Drive Shaft (Cont.)		
U-Joint			U-Joint (Cont.)		
1996-1991 Roadmaster: [Type 1]			1984-1982 Electra w/ Inner Lock Rings: [Type 1]		
	U-Joint (Front)⊙	UJ534G		U-Joint (Front)⊙	UJ534G
	Brute Force Greaseable	UJ235		Brute Force Greaseable	UJ235
	Brute Force Non Greaseable	UJ234		Brute Force Non Greaseable	UJ234
	Clamp Kit (Front)	UJ530-10		Clamp Kit (Front)	UJ530-10
	U-Joint (Rear)⊙	UJ534G		U-Joint (Rear)⊙	UJ534G
	Brute Force Greaseable	UJ235		Brute Force Greaseable	UJ235
	Brute Force Non Greaseable	UJ234		Brute Force Non Greaseable	UJ234
	Clamp Kit (Rear)	UJ530-10		Clamp Kit (Rear)	UJ530-10
1990-1986 LeSabre Estate Wagon: [Type 1]			1984-1982 Electra w/ Outer Lock Rings: [Type 1]		
	U-Joint (Front)⊙	UJ534G		U-Joint (Front)⊙	UJ331
	Brute Force Greaseable	UJ235		Brute Force Greaseable	UJ232
	Brute Force Non Greaseable	UJ234		Brute Force Non Greaseable	UJ231
	Clamp Kit (Front)	UJ530-10		(For Aluminum Drive Shaft)	UJ331C
	U-Joint (Rear)⊙	UJ534G		U-Joint (Rear)⊙	UJ331
	Brute Force Greaseable	UJ235		Brute Force Greaseable	UJ232
	Brute Force Non Greaseable	UJ234		Brute Force Non Greaseable	UJ231
	Clamp Kit (Rear)	UJ530-10		(For Aluminum Drive Shaft)	UJ331C
1985 Electra Estate Wagon: [Type 1]			1981-1973 Electra & LeSabre w/ 2 Joint Shaft: [Type 1]		
	U-Joint (Front)⊙	UJ534G		U-Joint (Front)⊙	UJ534G
	Brute Force Greaseable	UJ235		Brute Force Greaseable	UJ235
	Brute Force Non Greaseable	UJ234		Brute Force Non Greaseable	UJ234
	Clamp Kit (Front)	UJ530-10		Clamp Kit (Front)	UJ530-10
	U-Joint (Rear)⊙	UJ534G		U-Joint (Rear)⊙	UJ534G
	Brute Force Greaseable	UJ235		Brute Force Greaseable	UJ235
	Brute Force Non Greaseable	UJ234		Brute Force Non Greaseable	UJ234
	Clamp Kit (Rear)	UJ530-10		Clamp Kit (Rear)	UJ530-10
1985-1982 LeSabre w/ Inner Lock Rings: [Type 1]			1981-1973 Electra & LeSabre w/ "CV" at Rear Axle: [Type 1]		
	U-Joint (Front)⊙	UJ534G		U-Joint (Front)⊙	UJ534G
	Brute Force Greaseable	UJ235		Brute Force Greaseable	UJ235
	Brute Force Non Greaseable	UJ234		Brute Force Non Greaseable	UJ234
	Clamp Kit (Front)	UJ530-10		U-Joint (Rear)⊙	[2] UJ534G
	U-Joint (Rear)⊙	UJ534G		Brute Force Greaseable	UJ235
	Brute Force Greaseable	UJ235		Brute Force Non Greaseable	UJ234
	Brute Force Non Greaseable	UJ234		Ball Seat Repair Kit	UJ606
	Clamp Kit (Rear)	UJ530-10		Flange Yoke	UJ626
1985-1982 LeSabre w/ Outer Lock Rings: [Type 1]				H Yoke	UJ646
	U-Joint (Front)⊙	UJ331	1978-1977 Riviera: [Type 1]		
	Brute Force Greaseable	UJ232		U-Joint (Front)⊙	UJ534G
	Brute Force Non Greaseable	UJ231		Brute Force Greaseable	UJ235
	(For Aluminum Drive Shaft)	UJ331C		Brute Force Non Greaseable	UJ234
	U-Joint (Rear)⊙	UJ331		Clamp Kit (Front)	UJ530-10
	Brute Force Greaseable	UJ232		U-Joint (Rear)⊙	UJ534G
	Brute Force Non Greaseable	UJ231		Brute Force Greaseable	UJ235
	(For Aluminum Drive Shaft)	UJ331C		Brute Force Non Greaseable	UJ234
				Clamp Kit (Rear)	UJ530-10

(Continued)

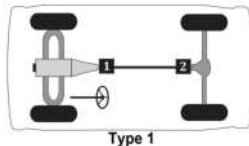

8 ▲ For Use w/ 1.063" Bearing Cap Application. ⊙ For Use w/ 1.188" Bearing Cap Application. ◇ For Use w/ Inner Lock Ring Application on Half Shaft. □ For Use w/ Outer Lock Ring Application on Half Shaft.

Passenger cars, light & medium trucks

(Cont.) -- Buick (RWD) Centurion, Electra (thru [1984]), Estate Wagon, Invicta, LeSabre (thru [1985]), Riviera (thru 1978), Roadmaster, Wildcat

MFG./YEAR	MODEL & LOCATION	PART NO.	MFG./YEAR	MODEL & LOCATION	PART NO.
Drive Shaft (Cont.)			Drive Shaft (Cont.)		
U-Joint (Cont.)			U-Joint (Cont.)		
1976-1973 Riviera: [Type 1]			1970-1968 Wildcat: [Type 1]		
U-Joint (Front)⓪		UJ534G	U-Joint (Front)⓪		UJ534G
Brute Force Greaseable		UJ235	Brute Force Greaseable		UJ235
Brute Force Non Greaseable		UJ234	Brute Force Non Greaseable		UJ234
U-Joint (Rear)⓪	[2]	UJ534G	U-Joint (Rear)⓪		UJ534G
Brute Force Greaseable		UJ235	Brute Force Greaseable		UJ235
Brute Force Non Greaseable		UJ234	Brute Force Non Greaseable		UJ234
Ball Seat Repair Kit		UJ606	1970-1964 Riviera: [Type 5]		
Flange Yoke		UJ626	U-Joint (Frnt. Shaft; Frnt.)⓪		UJ534G
H Yoke		UJ646	Brute Force Greaseable		UJ235
			Brute Force Non Greaseable		UJ234
1973 Centurion: [Type 1]			U-Joint (Frnt. Shaft; Rr.)⓪		UJ534G
U-Joint (Front)⓪		UJ534G	Brute Force Greaseable		UJ235
Brute Force Greaseable		UJ235	Brute Force Non Greaseable		UJ234
Brute Force Non Greaseable		UJ234	U-Joint (Rr. Shaft; Frnt.)⓪		UJ534G
U-Joint (Rear)⓪	[2]	UJ534G	Brute Force Greaseable		UJ235
Brute Force Greaseable		UJ235	Brute Force Non Greaseable		UJ234
Brute Force Non Greaseable		UJ234	U-Joint (Rr. Shaft; Rr.)⓪	[2]	UJ534G
Ball Seat Repair Kit		UJ606	Brute Force Greaseable		UJ235
Flange Yoke		UJ626	Brute Force Non Greaseable		UJ234
H Yoke		UJ646	1968-1963 Electra & LeSabre: [Type 5]		
			U-Joint (Frnt. Shaft; Frnt.)⓪		UJ534G
1972-1971 Centurion: [Type 1]			Brute Force Greaseable		UJ235
U-Joint (Front)⓪		UJ534G	Brute Force Non Greaseable		UJ234
Brute Force Greaseable		UJ235	U-Joint (Frnt. Shaft; Rr.)⓪		UJ492
Brute Force Non Greaseable		UJ234	U-Joint (Rr. Shaft; Frnt.)⓪		UJ492
U-Joint (Rear)⓪	[2]	UJ534G	U-Joint (Rr. Shaft; Rr.)⓪		UJ534G
Brute Force Greaseable		UJ235	Brute Force Greaseable		UJ235
Brute Force Non Greaseable		UJ234	Brute Force Non Greaseable		UJ234
1972-1971 Riviera: [Type 1]			1967-1963 Wildcat: [Type 5]		
U-Joint (Front)⓪		UJ534G	U-Joint (Frnt. Shaft; Frnt.)⓪		UJ534G
Brute Force Greaseable		UJ235	Brute Force Greaseable		UJ235
Brute Force Non Greaseable		UJ234	Brute Force Non Greaseable		UJ234
U-Joint (Rear)⓪	[2]	UJ534G	U-Joint (Frnt. Shaft; Rr.)⓪		UJ492
Brute Force Greaseable		UJ235	U-Joint (Rr. Shaft; Frnt.)⓪		UJ492
Brute Force Non Greaseable		UJ234	U-Joint (Rr. Shaft; Rr.)⓪		UJ534G
1972-1969 Electra & LeSabre w/ "CV" at Rear			Brute Force Greaseable		UJ235
Axle: [Type 1]			Brute Force Non Greaseable		UJ234
U-Joint (Front)⓪		UJ534G	1963 Riviera: [Type 2]		
Brute Force Greaseable		UJ235	U-Joint (Front)⓪		UJ534G
Brute Force Non Greaseable		UJ234	Brute Force Greaseable		UJ235
U-Joint (Rear)⓪	[2]	UJ534G	Brute Force Non Greaseable		UJ234
Brute Force Greaseable		UJ235	U-Joint (Center)⓪		UJ534G
Brute Force Non Greaseable		UJ234	Brute Force Greaseable		UJ235
1972-1969 Electra & LeSabre w/ 2 Joint Shaft:			Brute Force Non Greaseable		UJ234
[Type 1]			U-Joint (Rear)⓪		UJ534G
U-Joint (Front)⓪		UJ534G	Brute Force Greaseable		UJ235
Brute Force Greaseable		UJ235	Brute Force Non Greaseable		UJ234
Brute Force Non Greaseable		UJ234	(Continued)		
U-Joint (Rear)⓪		UJ534G			
Brute Force Greaseable		UJ235			
Brute Force Non Greaseable		UJ234			

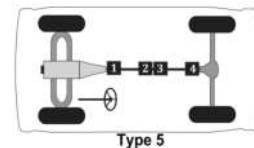
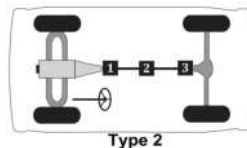
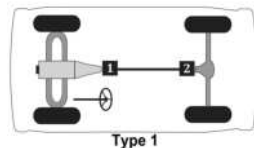

Passenger cars, light & medium trucks

Buick (RWD) Centurion, Electra (thru [1984]), Estate Wagon, Invicta, LeSabre (thru [1985]), Riviera (thru 1978), Roadmaster, Wildcat -- (Cont.)

MFG./YEAR	MODEL & LOCATION	PART NO.	MFG./YEAR	MODEL & LOCATION	PART NO.
Drive Shaft (Cont.)			Drive Shaft (Cont.)		
U-Joint (Cont.)			U-Joint (Cont.)		
1962-1961 Electra, Invicta, LeSabre & Wildcat w/ Inner Lock Rings: [Type 5]			1962-1961 Electra, Invicta, LeSabre & Wildcat w/ Outer Lock Rings: [Type 5]		
	U-Joint (Fr. Shaft; Frt.) [⊙]	UJ534G		U-Joint (Fr. Shaft; Frt.) [⊙]	UJ354
	Brute Force Greaseable	UJ235		Brute Force Greaseable	UJ270
	Brute Force Non Greaseable	UJ234		Brute Force Non Greaseable	UJ254
	U-Joint (Fr. Shaft; Rr.) [⊙]	UJ492		(For Aluminum Drive Shaft)	UJ354C
	U-Joint (Rr. Shaft; Frt.) [⊙]	UJ492		U-Joint (Fr. Shaft; Rr.) [⊙]	UJ354
	U-Joint (Rr. Shaft; Rr.) [⊙]	UJ534G		Brute Force Greaseable	UJ270
	Brute Force Greaseable	UJ235		Brute Force Non Greaseable	UJ254
	Brute Force Non Greaseable	UJ234		(For Aluminum Drive Shaft)	UJ354C
				U-Joint (Rr. Shaft; Frt.) [⊙]	UJ354
				Brute Force Greaseable	UJ270
				Brute Force Non Greaseable	UJ254
				(For Aluminum Drive Shaft)	UJ354C
				U-Joint (Rr. Shaft; Rr.) [⊙]	UJ355
				Brute Force Greaseable	UJ290
				(For Aluminum Drive Shaft)	UJ355C

Buick (RWD) Apollo, Skyhawk (thru [1980])

<p>Drive Shaft</p> <p>U-Joint</p> <p>1980-1975 Skyhawk: [Type 1]</p> <p>U-Joint (Front)[⊙]UJ369</p> <p>Brute Force GreaseableUJ280</p> <p>Brute Force Non GreaseableUJ269</p> <p>(For Aluminum Drive Shaft)UJ369C</p> <p>U-Bolt Kit (Front)UJ329-10</p> <p>U-Joint (Rear)[⊙]UJ369</p> <p>Brute Force GreaseableUJ280</p> <p>Brute Force Non GreaseableUJ269</p> <p>(For Aluminum Drive Shaft)UJ369C</p> <p>U-Bolt Kit (Rear)UJ329-10</p>	<p>Drive Shaft (Cont.)</p> <p>U-Joint (Cont.)</p> <p>1975-1973 Apollo: [Type 1]</p> <p>U-Joint (Front)[⊙]UJ369</p> <p>Brute Force GreaseableUJ280</p> <p>Brute Force Non GreaseableUJ269</p> <p>(For Aluminum Drive Shaft)UJ369C</p> <p>Clamp Kit (Front)UJ360-10</p> <p>U-Joint (Rear)[⊙]UJ369</p> <p>Brute Force GreaseableUJ280</p> <p>Brute Force Non GreaseableUJ269</p> <p>(For Aluminum Drive Shaft)UJ369C</p> <p>Clamp Kit (Rear)UJ360-10</p>
--	---

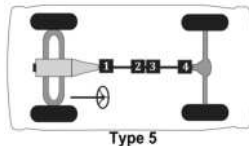
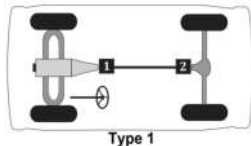

Passenger cars, light & medium trucks

Buick (RWD) Century (1973-1981), Regal (thru 1987), Skylark (thru 1979), Special (from 1961)

MFG./YEAR	MODEL & LOCATION	PART NO.	MFG./YEAR	MODEL & LOCATION	PART NO.
Drive Shaft			Drive Shaft (Cont.)		
U-Joint			U-Joint (Cont.)		
1987-1982 Regal w/ Inner Lock Rings: [Type 1]			1972-1968 Skylark: [Type 1]		
	U-Joint (Front)⓪	UJ534G		U-Joint (Front)⓪	UJ534G
	Brute Force Greaseable	UJ235		Brute Force Greaseable	UJ235
	Brute Force Non Greaseable	UJ234		Brute Force Non Greaseable	UJ234
	Clamp Kit (Front)	UJ530-10		U-Joint (Rear)⓪	UJ534G
	U-Joint (Rear)⓪	UJ534G		Brute Force Greaseable	UJ235
	Brute Force Greaseable	UJ235		Brute Force Non Greaseable	UJ234
	Brute Force Non Greaseable	UJ234		1969-1968 Special: [Type 1]	
	Clamp Kit (Rear)	UJ530-10		U-Joint (Front)⓪	UJ534G
	1987-1982 Regal w/ Outer Lock Rings: [Type 1]			Brute Force Greaseable	UJ235
	U-Joint (Front)⓪	UJ331		Brute Force Non Greaseable	UJ234
	Brute Force Greaseable	UJ232		U-Joint (Rear)⓪	UJ534G
	Brute Force Non Greaseable	UJ231		Brute Force Greaseable	UJ235
	(For Aluminum Drive Shaft)	UJ331C		Brute Force Non Greaseable	UJ234
	U-Joint (Rear)⓪	UJ331		1967-1966 Skylark & Special w/ 225 & 300 Eng.s.: [Type 1]	
	Brute Force Greaseable	UJ232		U-Joint (Front)⓪	UJ534G
	Brute Force Non Greaseable	UJ231		Brute Force Greaseable	UJ235
	(For Aluminum Drive Shaft)	UJ331C		Brute Force Non Greaseable	UJ234
	1981-1973 Century & Regal: [Type 1]			U-Joint (Rear)⓪	UJ534G
	U-Joint (Front)⓪	UJ534G		Brute Force Greaseable	UJ235
	Brute Force Greaseable	UJ235		Brute Force Non Greaseable	UJ234
	Brute Force Non Greaseable	UJ234		U-Joint (Rear)⓪	UJ534G
	Clamp Kit (Front)	UJ530-10		Brute Force Greaseable	UJ235
	U-Joint (Rear)⓪	UJ534G		Brute Force Non Greaseable	UJ234
	Brute Force Greaseable	UJ235		1967-1966 Skylark & Special w/ 340 Eng.: [Type 5]	
	Brute Force Non Greaseable	UJ234		U-Joint (Fr. Shaft; Frt.)⓪	UJ534G
	Clamp Kit (Rear)	UJ530-10		Brute Force Greaseable	UJ235
	1979-1975 Skylark w/ Inner Lock Rings: [Type 1]			Brute Force Non Greaseable	UJ234
	U-Joint (Front)⓪	UJ534G		U-Joint (Fr. Shaft; Rr.)⓪	UJ492
	Brute Force Greaseable	UJ235		U-Joint (Rr. Shaft; Frt.)⓪	UJ492
	Brute Force Non Greaseable	UJ234		U-Joint (Rr. Shaft; Rr.)⓪	UJ534G
	Clamp Kit (Front)	UJ530-10		Brute Force Greaseable	UJ235
	U-Joint (Rear)⓪	UJ534G		Brute Force Non Greaseable	UJ234
	Brute Force Greaseable	UJ235		1965-1964 Skylark & Special: [Type 1]	
	Brute Force Non Greaseable	UJ234		U-Joint (Front)⓪	UJ534G
	Clamp Kit (Rear)	UJ530-10		Brute Force Greaseable	UJ235
	1979-1975 Skylark w/ Outer Lock Rings: [Type 1]			Brute Force Non Greaseable	UJ234
	U-Joint (Front)⓪	UJ369		U-Joint (Rear)⓪	UJ534G
	Brute Force Greaseable	UJ280		Brute Force Greaseable	UJ235
	Brute Force Non Greaseable	UJ269		Brute Force Non Greaseable	UJ234
	(For Aluminum Drive Shaft)	UJ369C		U-Joint (Rear)⓪	UJ534G
	Clamp Kit (Front)	UJ360-10		Brute Force Greaseable	UJ235
	U-Joint (Rear)⓪	UJ369		Brute Force Non Greaseable	UJ234
	Brute Force Greaseable	UJ280			
	Brute Force Non Greaseable	UJ269			
	(For Aluminum Drive Shaft)	UJ369C			
	Clamp Kit (Rear)	UJ360-10			

(Continued)

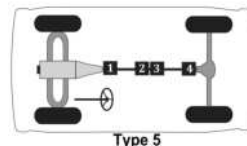
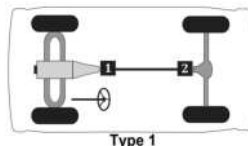

Passenger cars, light & medium trucks

Buick (RWD) Century (1973-1981), Regal (thru 1987), Skylark (thru 1979), Special (from 1961) -- (Cont.)

MFG./YEAR	MODEL & LOCATION	PART NO.	MFG./YEAR	MODEL & LOCATION	PART NO.
Drive Shaft (Cont.)			Drive Shaft (Cont.)		
U-Joint (Cont.)			U-Joint (Cont.)		
			1963-1961 Special: [Type 5]		
			U-Joint (Frnt. Shaft; Frt.)⊙UJ534G		
			Brute Force GreaseableUJ235		
			Brute Force Non GreaseableUJ234		
			U-Joint (Frnt. Shaft; Rr.)⊙UJ534G		
			Brute Force GreaseableUJ235		
			Brute Force Non GreaseableUJ234		
			U-Joint (Rr. Shaft; Frt.)⊙UJ534G		
			Brute Force GreaseableUJ235		
			Brute Force Non GreaseableUJ234		
			U-Joint (Rr. Shaft; Rr.)⊙ [2] UJ534G		
			Brute Force GreaseableUJ235		
			Brute Force Non GreaseableUJ234		

Cadillac (RWD) Brougham, Calais, Commercial Chassis, DeVille (thru 1984), Eldorado, Fleetwood (from 1993), Series 75, Seville (thru 1979)

<p>Drive Shaft</p> <p>U-Joint</p> <p>1996-1993 Brougham, Com. Chassis & Fleetwood w/ Armored Body: [Type 1]</p> <p>U-Joint (Front)⊙UJ534G</p> <p>Brute Force GreaseableUJ235</p> <p>Brute Force Non GreaseableUJ234</p> <p>U-Joint (Rear)⊙ [2] UJ534G</p> <p>Brute Force GreaseableUJ235</p> <p>Brute Force Non GreaseableUJ234</p> <p>Ball Seat Repair KitUJ606</p> <p>Flange YokeUJ626</p> <p>H YokeUJ646</p> <p>1996-1993 Brougham, Com. Chassis & Fleetwood Exc. Armored Body: [Type 1]</p> <p>U-Joint (Front)⊙UJ534G</p> <p>Brute Force GreaseableUJ235</p> <p>Brute Force Non GreaseableUJ234</p> <p>U-Joint (Rear)⊙UJ534G</p> <p>Brute Force GreaseableUJ235</p> <p>Brute Force Non GreaseableUJ234</p> <p>1992 Commercial Chassis Broham: [Type 1]</p> <p>U-Joint (Front)⊙UJ534G</p> <p>Brute Force GreaseableUJ235</p> <p>Brute Force Non GreaseableUJ234</p> <p>U-Joint (Rear)⊙UJ534G</p> <p>Brute Force GreaseableUJ235</p> <p>Brute Force Non GreaseableUJ234</p>	<p>Drive Shaft (Cont.)</p> <p>U-Joint (Cont.)</p> <p>1992-1987 Brougham: [Type 1]</p> <p>U-Joint (Front)⊙UJ534G</p> <p>Brute Force GreaseableUJ235</p> <p>Brute Force Non GreaseableUJ234</p> <p>U-Joint (Rear)⊙UJ534G</p> <p>Brute Force GreaseableUJ235</p> <p>Brute Force Non GreaseableUJ234</p> <p>1986-1985 Fleetwood Brougham: [Type 1]</p> <p>U-Joint (Front)⊙UJ534G</p> <p>Brute Force GreaseableUJ235</p> <p>Brute Force Non GreaseableUJ234</p> <p>Clamp Kit (Front)UJ530-10</p> <p>U-Joint (Rear)⊙UJ534G</p> <p>Brute Force GreaseableUJ235</p> <p>Brute Force Non GreaseableUJ234</p> <p>Clamp Kit (Rear)UJ530-10</p> <p style="text-align: right;">(Continued)</p>
--	--

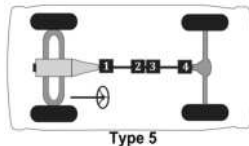
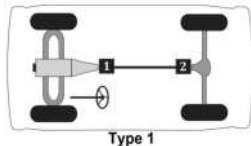

Passenger cars, light & medium trucks

(Cont.) -- Cadillac (RWD) Brougham, Calais, Commercial Chassis, DeVille (thru 1984), Eldorado, Fleetwood (from 1993), Series 75, Seville (thru 1979)

MFG./YEAR	MODEL & LOCATION	PART NO.	MFG./YEAR	MODEL & LOCATION	PART NO.
Drive Shaft (Cont.)			Drive Shaft (Cont.)		
U-Joint (Cont.)			U-Joint (Cont.)		
1985-1982 Comm. Chas. & Limo: [Type 5]			1981-1973 DeVille: [Type 1]		
	U-Joint (Frt. Shaft; Frt.) ^①	UJ534G		U-Joint (Front) ^①	[2] UJ534G
	Brute Force Greaseable	UJ235		Brute Force Greaseable	UJ235
	Brute Force Non Greaseable	UJ234		Brute Force Non Greaseable	UJ234
	U-Joint (Frt. Shaft; Rr.) ^②	UJ534G		U-Joint (Rear) ^②	[2] UJ534G
	Brute Force Greaseable	UJ235		Brute Force Greaseable	UJ235
	Brute Force Non Greaseable	UJ234		Brute Force Non Greaseable	UJ234
	U-Joint (Rr. Shaft; Frt.) ^③	UJ534G		Ball Seat Repair Kit	UJ606
	Brute Force Greaseable	UJ235		Flange Yoke	UJ626
	Brute Force Non Greaseable	UJ234		H Yoke	UJ646
	U-Joint (Rr. Shaft; Rr.) ^④	[2] UJ534G		1981-1973 Comm. Chas.: [Type 2]	
	Brute Force Greaseable	UJ235		U-Joint (Front) ^①	[2] UJ534G
	Brute Force Non Greaseable	UJ234		Brute Force Greaseable	UJ235
	Ball Seat Repair Kit	UJ606		Brute Force Non Greaseable	UJ234
	Flange Yoke	UJ626		U-Joint (Center) ^⑤	[2] UJ534G
	H Yoke	UJ646		Brute Force Greaseable	UJ235
	1984-1982 DeVille w/ Inner Lock Rings: [Type 1]			Brute Force Non Greaseable	UJ234
	U-Joint (Front) ^①	UJ534G		U-Joint (Rear) ^⑥	[2] UJ534G
	Brute Force Greaseable	UJ235		Brute Force Greaseable	UJ235
	Brute Force Non Greaseable	UJ234		Brute Force Non Greaseable	UJ234
	Clamp Kit (Front)	UJ530-10		Ball Seat Repair Kit	UJ606
	U-Joint (Rear) ^②	UJ534G		Flange Yoke	UJ626
	Brute Force Greaseable	UJ235		H Yoke	UJ646
	Brute Force Non Greaseable	UJ234		1981-1973 Fleetwood: [Type 1]	
	Clamp Kit (Rear)	UJ530-10		U-Joint (Front) ^①	[2] UJ534G
	1984-1982 Fleetwood: [Type 1]			Brute Force Greaseable	UJ235
	U-Joint (Front) ^①	UJ534G		Brute Force Non Greaseable	UJ234
	Brute Force Greaseable	UJ235		U-Joint (Rear) ^②	[2] UJ534G
	Brute Force Non Greaseable	UJ234		Brute Force Greaseable	UJ235
	Clamp Kit (Front)	UJ530-10		Brute Force Non Greaseable	UJ234
	U-Joint (Rear) ^②	UJ534G		Ball Seat Repair Kit	UJ606
	Brute Force Greaseable	UJ235		Flange Yoke	UJ626
	Brute Force Non Greaseable	UJ234		H Yoke	UJ646
	Clamp Kit (Rear)	UJ530-10		1979-1976 Seville: [Type 1]	
	1984-1982 DeVille w/ Outer Lock Rings: [Type 1]			U-Joint (Front) ^①	UJ534G
	U-Joint (Front) ^①	UJ331		Brute Force Greaseable	UJ235
	Brute Force Greaseable	UJ232		Brute Force Non Greaseable	UJ234
	Brute Force Non Greaseable	UJ231		U-Joint (Rear) ^②	[2] UJ534G
	(For Aluminum Drive Shaft)	UJ331C		Brute Force Greaseable	UJ235
	U-Joint (Rear) ^②	UJ331		Brute Force Non Greaseable	UJ234
	Brute Force Greaseable	UJ232		Ball Seat Repair Kit	UJ606
	Brute Force Non Greaseable	UJ231		Flange Yoke	UJ626
	(For Aluminum Drive Shaft)	UJ331C		H Yoke	UJ646

(Continued)

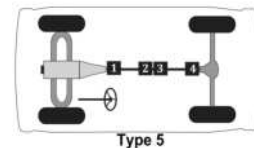
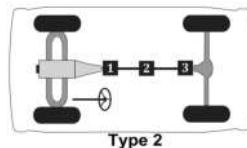
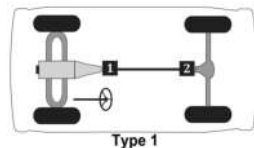

Passenger cars, light & medium trucks

Cadillac (RWD) Brougham, Calais, Commercial Chassis, DeVille (thru 1984), Eldorado, Fleetwood (from 1993), Series 75, Seville (thru 1979) -- (Cont.)

MFG./YEAR	MODEL & LOCATION	PART NO.	MFG./YEAR	MODEL & LOCATION	PART NO.
Drive Shaft (Cont.)			Drive Shaft (Cont.)		
U-Joint (Cont.)			U-Joint (Cont.)		
1976-1973 Calais: [Type 1]			1967-1965 Calais: [Type 5]		
	U-Joint (Front)Ⓚ	[2] UJ534G		U-Joint (Fr. Shaft; Fr.)Ⓚ	UJ534G
	Brute Force Greaseable	UJ235		Brute Force Greaseable	UJ235
	Brute Force Non Greaseable	UJ234		Brute Force Non Greaseable	UJ234
	U-Joint (Rear)Ⓚ	[2] UJ534G		U-Joint (Fr. Shaft; Rr.)Ⓚ	UJ534G
	Brute Force Greaseable	UJ235		Brute Force Greaseable	UJ235
	Brute Force Non Greaseable	UJ234		Brute Force Non Greaseable	UJ234
	Ball Seat Repair Kit	UJ606		U-Joint (Rr. Shaft; Fr.)Ⓚ	UJ534G
	Flange Yoke	UJ626		Brute Force Greaseable	UJ235
	H Yoke	UJ646		Brute Force Non Greaseable	UJ234
1972-1968 Calais: [Type 1]			U-Joint (Rr. Shaft; Rr.)Ⓚ		
	U-Joint (Front)Ⓚ	[2] UJ534G		[2] UJ534G	
	Brute Force Greaseable	UJ235		Brute Force Greaseable	UJ235
	Brute Force Non Greaseable	UJ234		Brute Force Non Greaseable	UJ234
	U-Joint (Rear)Ⓚ	[2] UJ534G	1967-1963 DeVille: [Type 5]		
	Brute Force Greaseable	UJ235		U-Joint (Fr. Shaft; Fr.)Ⓚ	UJ534G
	Brute Force Non Greaseable	UJ234		Brute Force Greaseable	UJ235
1972-1968 Fleetwood: [Type 1]				Brute Force Non Greaseable	UJ234
	U-Joint (Front)Ⓚ	[2] UJ534G		U-Joint (Fr. Shaft; Rr.)Ⓚ	UJ534G
	Brute Force Greaseable	UJ235		Brute Force Greaseable	UJ235
	Brute Force Non Greaseable	UJ234		Brute Force Non Greaseable	UJ234
	U-Joint (Rear)Ⓚ	[2] UJ534G		U-Joint (Rr. Shaft; Fr.)Ⓚ	UJ534G
	Brute Force Greaseable	UJ235		Brute Force Greaseable	UJ235
	Brute Force Non Greaseable	UJ234		Brute Force Non Greaseable	UJ234
1972-1968 DeVille: [Type 1]				U-Joint (Rr. Shaft; Rr.)Ⓚ	[2] UJ534G
	U-Joint (Front)Ⓚ	[2] UJ534G		Brute Force Greaseable	UJ235
	Brute Force Greaseable	UJ235		Brute Force Non Greaseable	UJ234
	Brute Force Non Greaseable	UJ234	1967-1963 Fleetwood: [Type 5]		
	U-Joint (Rear)Ⓚ	[2] UJ534G		U-Joint (Fr. Shaft; Fr.)Ⓚ	UJ534G
	Brute Force Greaseable	UJ235		Brute Force Greaseable	UJ235
	Brute Force Non Greaseable	UJ234		Brute Force Non Greaseable	UJ234
1972-1968 Comm. Chas.: [Type 2]				U-Joint (Fr. Shaft; Rr.)Ⓚ	UJ534G
	U-Joint (Front)Ⓚ	[2] UJ534G		Brute Force Greaseable	UJ235
	Brute Force Greaseable	UJ235		Brute Force Non Greaseable	UJ234
	Brute Force Non Greaseable	UJ234		U-Joint (Rr. Shaft; Fr.)Ⓚ	UJ534G
	U-Joint (Center)Ⓚ	[2] UJ534G		Brute Force Greaseable	UJ235
	Brute Force Greaseable	UJ235		Brute Force Non Greaseable	UJ234
	Brute Force Non Greaseable	UJ234		U-Joint (Rr. Shaft; Rr.)Ⓚ	[2] UJ534G
1967 Comm. Chassis & 75 Series: [Type 2]				Brute Force Greaseable	UJ235
	U-Joint (Front)Ⓚ	[2] UJ534G		Brute Force Non Greaseable	UJ234
	Brute Force Greaseable	UJ235		U-Joint (Center)Ⓚ	UJ534G
	Brute Force Non Greaseable	UJ234		Brute Force Greaseable	UJ235
	U-Joint (Center)Ⓚ	[2] UJ534G		Brute Force Non Greaseable	UJ234
	Brute Force Greaseable	UJ235		U-Joint (Rear)Ⓚ	UJ534G
	Brute Force Non Greaseable	UJ234		Brute Force Greaseable	UJ235
	U-Joint (Rear)Ⓚ	[2] UJ534G		Brute Force Non Greaseable	UJ234
	Brute Force Greaseable	UJ235			
	Brute Force Non Greaseable	UJ234			

(Continued)

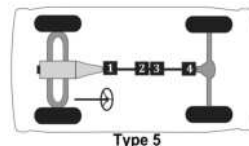
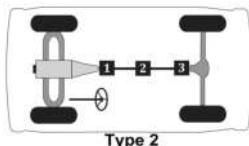
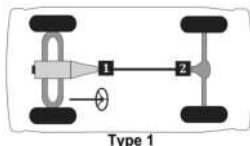

Passenger cars, light & medium trucks

(Cont.) -- Cadillac (RWD) Brougham, Calais, Commercial Chassis, DeVille (thru 1984), Eldorado, Fleetwood (from 1993), Series 75, Seville (thru 1979)

MFG./YEAR	MODEL & LOCATION	PART NO.	MFG./YEAR	MODEL & LOCATION	PART NO.
-----------	------------------	----------	-----------	------------------	----------

Drive Shaft (Cont.)

U-Joint (Cont.)

1964-1963 Eldorado: [Type 5]

U-Joint (Frt. Shaft; Frt.) ^①	UJ534G
Brute Force Greaseable	UJ235
Brute Force Non Greaseable	UJ234
U-Joint (Frt. Shaft; Rr.) ^②	UJ534G
Brute Force Greaseable	UJ235
Brute Force Non Greaseable	UJ234
U-Joint (Rr. Shaft; Frt.) ^③	UJ534G
Brute Force Greaseable	UJ235
Brute Force Non Greaseable	UJ234
U-Joint (Rr. Shaft; Rr.) ^④	[2] UJ534G
Brute Force Greaseable	UJ235
Brute Force Non Greaseable	UJ234

1962-1958 DeVille w/ Inner Lock Rings: [Type 2]

U-Joint (Front) ^①	UJ534G
Brute Force Greaseable	UJ235
Brute Force Non Greaseable	UJ234
U-Joint (Center) ^②	UJ534G
Brute Force Greaseable	UJ235
Brute Force Non Greaseable	UJ234
U-Joint (Rear) ^③	UJ534G
Brute Force Greaseable	UJ235
Brute Force Non Greaseable	UJ234

1962-1958 Comm. Chassis & 75 Series w/ Inner

Lock Rings: [Type 2]

U-Joint (Front) ^①	UJ534G
Brute Force Greaseable	UJ235
Brute Force Non Greaseable	UJ234
U-Joint (Center) ^②	UJ534G
Brute Force Greaseable	UJ235
Brute Force Non Greaseable	UJ234
U-Joint (Rear) ^③	UJ534G
Brute Force Greaseable	UJ235
Brute Force Non Greaseable	UJ234

1962-1958 DeVille w/ Outer Lock Rings: [Type 2]

U-Joint (Front) ^①	UJ354
Brute Force Greaseable	UJ270
Brute Force Non Greaseable	UJ254
(For Aluminum Drive Shaft)	UJ354C
U-Joint (Center) ^②	UJ354
Brute Force Greaseable	UJ270
Brute Force Non Greaseable	UJ254
(For Aluminum Drive Shaft)	UJ354C
U-Joint (Rear) ^③	UJ355
Brute Force Greaseable	UJ290
(For Aluminum Drive Shaft)	UJ355C

Drive Shaft (Cont.)

U-Joint (Cont.)

1962-1958 Comm. Chassis & 75 Series w/ Outer

Lock Rings: [Type 2]

U-Joint (Front) ^①	UJ354
Brute Force Greaseable	UJ270
Brute Force Non Greaseable	UJ254
(For Aluminum Drive Shaft)	UJ354C
U-Joint (Center) ^②	UJ354
Brute Force Greaseable	UJ270
Brute Force Non Greaseable	UJ254
(For Aluminum Drive Shaft)	UJ354C
U-Joint (Rear) ^③	UJ355
Brute Force Greaseable	UJ290
(For Aluminum Drive Shaft)	UJ355C

1962-1957 Eldorado w/ Inner Lock Rings: [Type 2]

U-Joint (Front) ^①	UJ534G
Brute Force Greaseable	UJ235
Brute Force Non Greaseable	UJ234
U-Joint (Center) ^②	UJ534G
Brute Force Greaseable	UJ235
Brute Force Non Greaseable	UJ234
U-Joint (Rear) ^③	UJ534G
Brute Force Greaseable	UJ235
Brute Force Non Greaseable	UJ234

1962-1957 Eldorado w/ Outer Lock Rings: [Type 2]

U-Joint (Front) ^①	UJ354
Brute Force Greaseable	UJ270
Brute Force Non Greaseable	UJ254
(For Aluminum Drive Shaft)	UJ354C
U-Joint (Center) ^②	UJ354
Brute Force Greaseable	UJ270
Brute Force Non Greaseable	UJ254
(For Aluminum Drive Shaft)	UJ354C
U-Joint (Rear) ^③	UJ355
Brute Force Greaseable	UJ290
(For Aluminum Drive Shaft)	UJ355C

1957 DeVille: [Type 2]

U-Joint (Front) ^①	UJ534G
Brute Force Greaseable	UJ235
Brute Force Non Greaseable	UJ234
U-Joint (Center) ^②	UJ534G
Brute Force Greaseable	UJ235
Brute Force Non Greaseable	UJ234
U-Joint (Rear) ^③	UJ534G
Brute Force Greaseable	UJ235
Brute Force Non Greaseable	UJ234

(Continued)

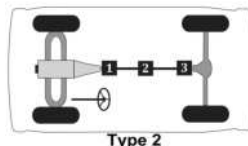

Type 2

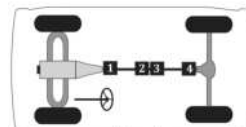

Type 5

Passenger cars, light & medium trucks

Cadillac (RWD) Brougham, Calais, Commercial Chassis, DeVille (thru 1984), Eldorado, Fleetwood (from 1993), Series 75, Seville (thru 1979) -- (Cont.)

MFG./YEAR	MODEL & LOCATION	PART NO.	MFG./YEAR	MODEL & LOCATION	PART NO.
Drive Shaft (Cont.)			Drive Shaft (Cont.)		
U-Joint (Cont.)			U-Joint (Cont.)		
1957	Comm. Chassis & 75 Series: [Type 2]		1956-1950	Comm. Chassis & 75 Series w/ 3 Joint Shaft: [Type 2]	
	U-Joint (Front)Ⓛ	UJ534G		U-Joint (Front)Ⓛ	UJ531G
	Brute Force Greaseable	UJ235		U-Joint (Center)Ⓞ	UJ531G
	Brute Force Non Greaseable	UJ234		U-Joint (Rear)Ⓞ	UJ531G
	U-Joint (Center)Ⓞ	UJ534G	1950-1946	Comm. Chassis & 75 Series w/ 3 Joint Shaft: [Type 2]	
	Brute Force Greaseable	UJ235		U-Joint (Front)Ⓛ	UJ536
	Brute Force Non Greaseable	UJ234		U-Joint (Center)Ⓞ	UJ536
	U-Joint (Rear)Ⓞ	UJ534G		U-Joint (Rear)Ⓞ	UJ536
	Brute Force Greaseable	UJ235	1949-1946	DeVile w/ 2 Joint Shaft: [Type 1]	
	Brute Force Non Greaseable	UJ234		U-Joint (Front)Ⓛ	UJ536
1956-1953	Eldorado w/ 2 Joint Shaft: [Type 1]			U-Joint (Rear)Ⓞ	UJ536
	U-Joint (Front)Ⓛ	UJ534G	1949-1946	DeVile w/ 3 Joint Shaft: [Type 2]	
	Brute Force Greaseable	UJ235		U-Joint (Front)Ⓛ	UJ536
	Brute Force Non Greaseable	UJ234		U-Joint (Center)Ⓞ	UJ536
	U-Joint (Rear)Ⓞ	UJ531G		U-Joint (Rear)Ⓞ	UJ536
1956-1953	Eldorado w/ 3 Joint Shaft: [Type 2]		1949-1946	Comm. Chassis & 75 Series w/ 2 Joint Shaft: [Type 1]	
	U-Joint (Front)Ⓛ	UJ531G		U-Joint (Front)Ⓛ	UJ536
	U-Joint (Center)Ⓞ	UJ531G		U-Joint (Rear)Ⓞ	UJ536
	U-Joint (Rear)Ⓞ	UJ531G			
1956-1950	DeVile w/ 2 Joint Shaft: [Type 1]				
	U-Joint (Front)Ⓛ	UJ534G			
	Brute Force Greaseable	UJ235			
	Brute Force Non Greaseable	UJ234			
	U-Joint (Rear)Ⓞ	UJ531G			
1956-1950	DeVile w/ 3 Joint Shaft: [Type 2]				
	U-Joint (Front)Ⓛ	UJ531G			
	U-Joint (Center)Ⓞ	UJ531G			
	U-Joint (Rear)Ⓞ	UJ531G			
1956-1950	Comm. Chassis & 75 Series w/ 2 Joint Shaft: [Type 1]				
	U-Joint (Front)Ⓛ	UJ534G			
	Brute Force Greaseable	UJ235			
	Brute Force Non Greaseable	UJ234			
	U-Joint (Rear)Ⓞ	UJ531G			

Cadillac (RWD) ATS, ATS-V, CT6, CTS, CTS-V, STS, STS-V

Drive Shaft	
U-Joint	
2014-2011 CTS:	
Flex Coupler	VKJF98020
2006-2003 CTS:	
Flex Coupler	VKJF98013

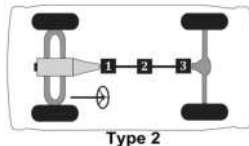
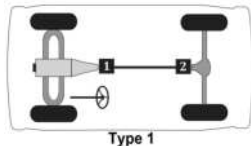

Passenger cars, light & medium trucks

Checker Motors Corp.

MFG./YEAR	MODEL & LOCATION	PART NO.	MFG./YEAR	MODEL & LOCATION	PART NO.
Drive Shaft			Drive Shaft (Cont.)		
U-Joint			U-Joint (Cont.)		
1977-1974 Marathon & Taxi: [Type 1]			1971-1969 Marathon & Taxi: [Type 1]		
	U-Joint (Front)❶	UJ354		U-Joint (Front)❶	UJ354
	Brute Force Greaseable	UJ270		Brute Force Greaseable	UJ270
	Brute Force Non Greaseable	UJ254		Brute Force Non Greaseable	UJ254
	(For Aluminum Drive Shaft)	UJ354C		(For Aluminum Drive Shaft)	UJ354C
	U-Joint (Rear)❷	UJ369		U-Joint (Rear)❷	UJ354
	Brute Force Greaseable	UJ280		Brute Force Greaseable	UJ270
	Brute Force Non Greaseable	UJ269		Brute Force Non Greaseable	UJ254
	(For Aluminum Drive Shaft)	UJ369C		(For Aluminum Drive Shaft)	UJ354C
1974-1965 AeroBus: [Type 2]			1968-1962 Marathon & Taxi: [Type 1]		
	U-Joint (Front)❶	UJ369		U-Joint (Front)❶	UJ369
	Brute Force Greaseable	UJ280		Brute Force Greaseable	UJ280
	Brute Force Non Greaseable	UJ269		Brute Force Non Greaseable	UJ269
	(For Aluminum Drive Shaft)	UJ369C		(For Aluminum Drive Shaft)	UJ369C
	U-Joint (Center)❸	UJ369		U-Joint (Rear)❷	UJ369
	Brute Force Greaseable	UJ280		Brute Force Greaseable	UJ280
	Brute Force Non Greaseable	UJ269		Brute Force Non Greaseable	UJ269
	(For Aluminum Drive Shaft)	UJ369C		(For Aluminum Drive Shaft)	UJ369C
	U-Joint (Rear)❷	UJ369			
	Brute Force Greaseable	UJ280			
	Brute Force Non Greaseable	UJ269			
	(For Aluminum Drive Shaft)	UJ369C			
1973-1972 Marathon & Taxi: [Type 1]					
	U-Joint (Front)❶	UJ369			
	Brute Force Greaseable	UJ280			
	Brute Force Non Greaseable	UJ269			
	(For Aluminum Drive Shaft)	UJ369C			
	U-Joint (Rear)❷	UJ369			
	Brute Force Greaseable	UJ280			
	Brute Force Non Greaseable	UJ269			
	(For Aluminum Drive Shaft)	UJ369C			

Chevrolet (RWD) Bel Air, Biscayne, Caprice (thru 1996), Del Ray, Impala (thru 1996), One-Fifty, Two-Ten

Drive Shaft		Drive Shaft (Cont.)	
U-Joint		U-Joint (Cont.)	
2017-2014 SS:		1984-1982 Caprice & Impala w/ Inner Lock Rings:	
	Flex Coupler		[Type 1]
	Flex Coupler		U-Joint (Front)❶
	Flex Coupler		Brute Force Greaseable
	Flex Coupler		Brute Force Non Greaseable
	Flex Coupler		Clamp Kit (Front)
	Flex Coupler		U-Joint (Rear)❷
	Flex Coupler		Brute Force Greaseable
	Flex Coupler		Brute Force Non Greaseable
	Flex Coupler		Clamp Kit (Rear)
	Flex Coupler		(Continued)

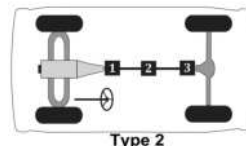
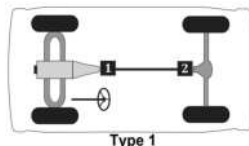

Passenger cars, light & medium trucks

Chevrolet (RWD) Bel Air, Biscayne, Caprice (thru 1996), Del Ray, Impala (thru 1996), One-Fifty, Two-Ten -- (Cont.)

MFG./YEAR	MODEL & LOCATION	PART NO.	MFG./YEAR	MODEL & LOCATION	PART NO.
Drive Shaft (Cont.)			Drive Shaft (Cont.)		
U-Joint (Cont.)			U-Joint (Cont.)		
1984-1982 Caprice & Impala w/ Outer Lock Rings: [Type 1]			1975-1971 Station Wagon w/ Outer Lock Rings: [Type 1]		
U-Joint (Front)Ⓚ		UJ331	U-Joint (Front)Ⓚ		UJ369
Brute Force Greaseable		UJ232	Brute Force Greaseable		UJ280
Brute Force Non Greaseable		UJ231	Brute Force Non Greaseable		UJ269
(For Aluminum Drive Shaft)		UJ331C	(For Aluminum Drive Shaft)		UJ369C
U-Joint (Rear)Ⓚ		UJ331	U-Bolt Kit (Front)		UJ329-10
Brute Force Greaseable		UJ232	U-Joint (Rear)Ⓚ		UJ369
Brute Force Non Greaseable		UJ231	Brute Force Greaseable		UJ280
(For Aluminum Drive Shaft)		UJ331C	Brute Force Non Greaseable		UJ269
1981-1977 Bel Air, Caprice & Impala: [Type 1]			(For Aluminum Drive Shaft)		UJ369C
U-Joint (Front)Ⓚ		UJ534G	U-Bolt Kit (Rear)		UJ329-10
Brute Force Greaseable		UJ235	1972-1971 Sedan: [Type 1]		
Brute Force Non Greaseable		UJ234	U-Joint (Front)Ⓚ		UJ534G
Clamp Kit (Front)		UJ530-10	Brute Force Greaseable		UJ235
U-Joint (Rear)Ⓚ		UJ534G	Brute Force Non Greaseable		UJ234
Brute Force Greaseable		UJ235	U-Joint (Rear)Ⓚ	[2]	UJ534G
Brute Force Non Greaseable		UJ234	Brute Force Greaseable		UJ235
Clamp Kit (Rear)		UJ530-10	Brute Force Non Greaseable		UJ234
1976 Caprice & Impala: [Type 1]			1970-1969 Bel Air, Biscayne & Impala: [Type 1]		
U-Joint (Front)Ⓚ		UJ534G	U-Joint (Front)Ⓚ		UJ369
Brute Force Greaseable		UJ235	Brute Force Greaseable		UJ280
Brute Force Non Greaseable		UJ234	Brute Force Non Greaseable		UJ269
U-Joint (Rear)Ⓚ	[2]	UJ534G	(For Aluminum Drive Shaft)		UJ369C
Brute Force Greaseable		UJ235	U-Bolt Kit (Front)		UJ329-10
Brute Force Non Greaseable		UJ234	U-Joint (Rear)Ⓚ		UJ369
Ball Seat Repair Kit		UJ606	Brute Force Greaseable		UJ280
Flange Yoke		UJ626	Brute Force Non Greaseable		UJ269
H Yoke		UJ646	(For Aluminum Drive Shaft)		UJ369C
1975-1973 Sedan: [Type 1]			U-Bolt Kit (Rear)		UJ329-10
U-Joint (Front)Ⓚ		UJ534G	1970-1969 Caprice w/ Turbo Hydramatic Trans.: [Type 1]		
Brute Force Greaseable		UJ235	U-Joint (Front)Ⓚ		UJ534G
Brute Force Non Greaseable		UJ234	Brute Force Greaseable		UJ235
U-Joint (Rear)Ⓚ	[2]	UJ534G	Brute Force Non Greaseable		UJ234
Brute Force Greaseable		UJ235	U-Joint (Rear)Ⓚ		UJ355
Brute Force Non Greaseable		UJ234	Brute Force Greaseable		UJ290
Ball Seat Repair Kit		UJ606	(For Aluminum Drive Shaft)		UJ355C
Flange Yoke		UJ626	1970-1969 Caprice w/o Turbo Hydramatic Trans.: [Type 1]		
H Yoke		UJ646	U-Joint (Front)Ⓚ		UJ369
1975-1971 Station Wagon w/ Inner Lock Rings: [Type 1]			Brute Force Greaseable		UJ280
U-Joint (Front)Ⓚ		UJ534G	Brute Force Non Greaseable		UJ269
Brute Force Greaseable		UJ235	(For Aluminum Drive Shaft)		UJ369C
Brute Force Non Greaseable		UJ234	U-Bolt Kit (Front)		UJ329-10
Clamp Kit (Front)		UJ530-10	U-Joint (Rear)Ⓚ		UJ369
U-Joint (Rear)Ⓚ		UJ534G	Brute Force Greaseable		UJ280
Brute Force Greaseable		UJ235	Brute Force Non Greaseable		UJ269
Brute Force Non Greaseable		UJ234	(For Aluminum Drive Shaft)		UJ369C
Clamp Kit (Rear)		UJ530-10	U-Bolt Kit (Rear)		UJ329-10

(Continued)

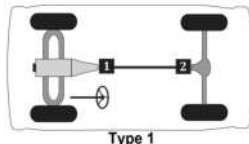

Passenger cars, light & medium trucks

(Cont.) -- Chevrolet (RWD) Bel Air, Biscayne, Caprice (thru 1996), Del Ray, Impala (thru 1996), One-Fifty, Two-Ten

MFG./YEAR	MODEL & LOCATION	PART NO.	MFG./YEAR	MODEL & LOCATION	PART NO.
Drive Shaft (Cont.)			Drive Shaft (Cont.)		
U-Joint (Cont.)			U-Joint (Cont.)		
1968-1966 Bel Air, Biscayne, Caprice & Impala w/ Turbo Hydramatic Trans.: [Type 1]			1964-1958 Bel Air, Biscayne, Del Ray & Impala: [Type 2]		
	U-Joint (Front)Ⓢ	UJ534G		U-Joint (Front)Ⓢ	UJ369
	Brute Force Greaseable	UJ235		Brute Force Greaseable	UJ280
	Brute Force Non Greaseable	UJ234		Brute Force Non Greaseable	UJ269
	U-Joint (Rear)Ⓢ	UJ355		(For Aluminum Drive Shaft)	UJ369C
	Brute Force Greaseable	UJ290		U-Bolt Kit (Front)	UJ329-10
	(For Aluminum Drive Shaft)	UJ355C		U-Joint (Center)Ⓢ	UJ369
1968-1966 Bel Air, Biscayne, Caprice & Impala w/o Turbo Hydramatic Trans.: [Type 1]				Brute Force Greaseable	UJ280
	U-Joint (Front)Ⓢ	UJ369		Brute Force Non Greaseable	UJ269
	Brute Force Greaseable	UJ280		(For Aluminum Drive Shaft)	UJ369C
	Brute Force Non Greaseable	UJ269		U-Bolt Kit (Center)	UJ329-10
	(For Aluminum Drive Shaft)	UJ369C		U-Joint (Rear)Ⓢ	UJ369
	U-Bolt Kit (Front)	UJ329-10		Brute Force Greaseable	UJ280
	U-Joint (Rear)Ⓢ	UJ369		Brute Force Non Greaseable	UJ269
	Brute Force Greaseable	UJ280		(For Aluminum Drive Shaft)	UJ369C
	Brute Force Non Greaseable	UJ269		U-Bolt Kit (Rear)	UJ329-10
	(For Aluminum Drive Shaft)	UJ369C	1957-1955 Bel Air, Del Ray, One-Fifty & Two-Ten: [Type 1]		
	U-Bolt Kit (Rear)	UJ329-10		U-Joint (Front)Ⓢ	UJ369
1965 Bel Air, Biscayne & Impala: [Type 1]				Brute Force Greaseable	UJ280
	U-Joint (Front)Ⓢ	UJ369		Brute Force Non Greaseable	UJ269
	Brute Force Greaseable	UJ280		(For Aluminum Drive Shaft)	UJ369C
	Brute Force Non Greaseable	UJ269		U-Bolt Kit (Front)	UJ329-10
	(For Aluminum Drive Shaft)	UJ369C		U-Joint (Rear)Ⓢ	UJ369
	U-Bolt Kit (Front)	UJ329-10		Brute Force Greaseable	UJ280
	U-Joint (Rear)Ⓢ	UJ369		Brute Force Non Greaseable	UJ269
	Brute Force Greaseable	UJ280		(For Aluminum Drive Shaft)	UJ369C
	Brute Force Non Greaseable	UJ269		U-Bolt Kit (Rear)	UJ329-10
	(For Aluminum Drive Shaft)	UJ369C			
	U-Bolt Kit (Rear)	UJ329-10			

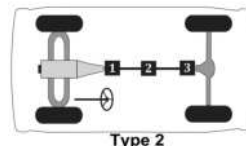
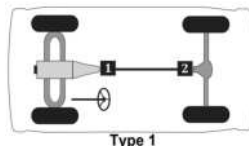

Passenger cars, light & medium trucks

Chevrolet (RWD) Chevy II, Nova (thru 1979)

MFG./YEAR	MODEL & LOCATION	PART NO.	MFG./YEAR	MODEL & LOCATION	PART NO.
Drive Shaft			Drive Shaft (Cont.)		
U-Joint			U-Joint (Cont.)		
1979-1969 Nova: [Type 1]			1968-1962 Chevy II: [Type 1]		
	U-Joint (Front)	UJ369		U-Joint (Front)	UJ369
	Brute Force Greaseable	UJ280		Brute Force Greaseable	UJ280
	Brute Force Non Greaseable	UJ269		Brute Force Non Greaseable	UJ269
	(For Aluminum Drive Shaft)	UJ369C		(For Aluminum Drive Shaft)	UJ369C
	Clamp Kit (Front)	UJ360-10		U-Bolt Kit (Front)	UJ329-10
	U-Joint (Rear)	UJ369		U-Joint (Rear)	UJ369
	Brute Force Greaseable	UJ280		Brute Force Greaseable	UJ280
	Brute Force Non Greaseable	UJ269		Brute Force Non Greaseable	UJ269
	(For Aluminum Drive Shaft)	UJ369C		(For Aluminum Drive Shaft)	UJ369C
	Clamp Kit (Rear)	UJ360-10		U-Bolt Kit (Rear)	UJ329-10

Chevrolet (RWD) Camaro, Chevelle, El Camino, Laguna, Malibu (1971-1983), Monte Carlo (thru 1988), Nomad

<p>Drive Shaft</p> <p>U-Joint</p> <p>2002-1993 Camaro: [Type 1]</p> <p>U-Joint (Front) UJ534G</p> <p>Brute Force Greaseable UJ235</p> <p>Brute Force Non Greaseable UJ234</p> <p>Clamp Kit (Front) UJ530-10</p> <p>U-Joint (Rear) UJ534G</p> <p>Brute Force Greaseable UJ235</p> <p>Brute Force Non Greaseable UJ234</p> <p>Clamp Kit (Rear) UJ530-10</p> <p>1992-1988 Camaro w/ Aluminum Drive Shaft:</p> <p style="padding-left: 20px;">[Type 1]</p> <p>U-Joint (Front) UJ369</p> <p>Brute Force Greaseable UJ280</p> <p>Brute Force Non Greaseable UJ269</p> <p>(For Aluminum Drive Shaft) UJ369C</p> <p>U-Joint (Rear) UJ372</p> <p>(For Aluminum Drive Shaft) UJ372C</p> <p>Clamp Kit (Rear) UJ530-10</p> <p>1992-1988 Camaro w/ Steel Drive Shaft: [Type 1]</p> <p>U-Joint (Front) UJ534G</p> <p>Brute Force Greaseable UJ235</p> <p>Brute Force Non Greaseable UJ234</p> <p>Clamp Kit (Front) UJ530-10</p> <p>U-Joint (Rear) UJ534G</p> <p>Brute Force Greaseable UJ235</p> <p>Brute Force Non Greaseable UJ234</p> <p>Clamp Kit (Rear) UJ530-10</p>	<p>Drive Shaft (Cont.)</p> <p>U-Joint (Cont.)</p> <p>1988-1985 El Camino & Monte Carlo: [Type 1]</p> <p>U-Joint (Front) UJ534G</p> <p>Brute Force Greaseable UJ235</p> <p>Brute Force Non Greaseable UJ234</p> <p>Clamp Kit (Front) UJ530-10</p> <p>U-Joint (Rear) UJ534G</p> <p>Brute Force Greaseable UJ235</p> <p>Brute Force Non Greaseable UJ234</p> <p>Clamp Kit (Rear) UJ530-10</p> <p>1987-1985 Camaro: [Type 1]</p> <p>U-Joint (Front) UJ534G</p> <p>Brute Force Greaseable UJ235</p> <p>Brute Force Non Greaseable UJ234</p> <p>Clamp Kit (Front) UJ530-10</p> <p>U-Joint (Rear) UJ534G</p> <p>Brute Force Greaseable UJ235</p> <p>Brute Force Non Greaseable UJ234</p> <p>Clamp Kit (Rear) UJ530-10</p> <p>1984-1982 Camaro w/ Inner Lock Rings: [Type 1]</p> <p>U-Joint (Front) UJ534G</p> <p>Brute Force Greaseable UJ235</p> <p>Brute Force Non Greaseable UJ234</p> <p>Clamp Kit (Front) UJ530-10</p> <p>U-Joint (Rear) UJ534G</p> <p>Brute Force Greaseable UJ235</p> <p>Brute Force Non Greaseable UJ234</p> <p>Clamp Kit (Rear) UJ530-10</p> <p style="text-align: right;">(Continued)</p>
---	---

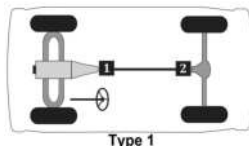

Passenger cars, light & medium trucks

(Cont.) -- Chevrolet (RWD) Camaro, Chevelle, El Camino, Laguna, Malibu (1971-1983), Monte Carlo (thru 1988), Nomad

MFG./YEAR	MODEL & LOCATION	PART NO.	MFG./YEAR	MODEL & LOCATION	PART NO.
Drive Shaft (Cont.)			Drive Shaft (Cont.)		
U-Joint (Cont.)			U-Joint (Cont.)		
1984-1982 El Camino, Malibu & Monte Carlo w/ Inner Lock Rings: [Type 1]			1975-1969 Camaro: [Type 1]		
	U-Joint (Front)Ⓢ	UJ534G		U-Joint (Front)Ⓢ	UJ369
	Brute Force Greaseable	UJ235		Brute Force Greaseable	UJ280
	Brute Force Non Greaseable	UJ234		Brute Force Non Greaseable	UJ269
	Clamp Kit (Front)	UJ530-10		(For Aluminum Drive Shaft)	UJ369C
	U-Joint (Rear)Ⓢ	UJ534G		U-Joint (Rear)Ⓢ	UJ369
	Brute Force Greaseable	UJ235		Brute Force Greaseable	UJ280
	Brute Force Non Greaseable	UJ234		Brute Force Non Greaseable	UJ269
	Clamp Kit (Rear)	UJ530-10		(For Aluminum Drive Shaft)	UJ369C
1984-1982 Camaro w/ Outer Lock Rings: [Type 1]			1972-1971 Chevelle, El Camino & Monte Carlo w/ 454 V-8: [Type 1]		
	U-Joint (Front)Ⓢ	UJ331		U-Joint (Front)Ⓢ	UJ534G
	Brute Force Greaseable	UJ232		Brute Force Greaseable	UJ235
	Brute Force Non Greaseable	UJ231		Brute Force Non Greaseable	UJ234
	(For Aluminum Drive Shaft)	UJ331C		U-Joint (Rear)Ⓢ	UJ355
	U-Joint (Rear)Ⓢ	UJ331		Brute Force Greaseable	UJ290
	Brute Force Greaseable	UJ232		(For Aluminum Drive Shaft)	UJ355C
	Brute Force Non Greaseable	UJ231	1972-1971 Chevelle, El Camino & Monte Carlo w/o 454 V-8: [Type 1]		
	(For Aluminum Drive Shaft)	UJ331C		U-Joint (Front)Ⓢ	UJ369
1984-1982 El Camino, Malibu & Monte Carlo w/ Outer Lock Rings: [Type 1]				Brute Force Greaseable	UJ280
	U-Joint (Front)Ⓢ	UJ331		Brute Force Non Greaseable	UJ269
	Brute Force Greaseable	UJ232		(For Aluminum Drive Shaft)	UJ369C
	Brute Force Non Greaseable	UJ231		U-Bolt Kit (Front)	UJ329-10
	(For Aluminum Drive Shaft)	UJ331C		U-Joint (Rear)Ⓢ	UJ369
	U-Joint (Rear)Ⓢ	UJ331		Brute Force Greaseable	UJ280
	Brute Force Greaseable	UJ232		Brute Force Non Greaseable	UJ269
	Brute Force Non Greaseable	UJ231		(For Aluminum Drive Shaft)	UJ369C
	(For Aluminum Drive Shaft)	UJ331C		U-Bolt Kit (Rear)	UJ329-10
1981-1976 Camaro: [Type 1]			1970-1969 Chevelle, El Camino & Monte Carlo: [Type 1]		
	U-Joint (Front)Ⓢ	UJ534G		U-Joint (Front)Ⓢ	UJ369
	Brute Force Greaseable	UJ235		Brute Force Greaseable	UJ280
	Brute Force Non Greaseable	UJ234		Brute Force Non Greaseable	UJ269
	Clamp Kit (Front)	UJ530-10		(For Aluminum Drive Shaft)	UJ369C
	U-Joint (Rear)Ⓢ	UJ534G		U-Bolt Kit (Front)	UJ329-10
	Brute Force Greaseable	UJ235		U-Joint (Rear)Ⓢ	UJ369
	Brute Force Non Greaseable	UJ234		Brute Force Greaseable	UJ280
	Clamp Kit (Rear)	UJ530-10		Brute Force Non Greaseable	UJ269
1981-1973 Chevelle, El Camino, Laguna, Malibu & Monte Carlo: [Type 1]				(For Aluminum Drive Shaft)	UJ369C
	U-Joint (Front)Ⓢ	UJ534G		U-Bolt Kit (Rear)	UJ329-10
	Brute Force Greaseable	UJ235	(Continued)		
	Brute Force Non Greaseable	UJ234			
	Clamp Kit (Front)	UJ530-10			
	U-Joint (Rear)Ⓢ	UJ534G			
	Brute Force Greaseable	UJ235			
	Brute Force Non Greaseable	UJ234			
	Clamp Kit (Rear)	UJ530-10			

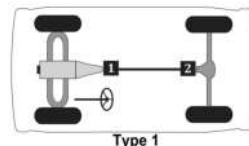

Passenger cars, light & medium trucks

Chevrolet (RWD) Camaro, Chevelle, El Camino, Laguna, Malibu (1971-1983), Monte Carlo (thru 1988), Nomad -- (Cont.)

MFG./YEAR	MODEL & LOCATION	PART NO.	MFG./YEAR	MODEL & LOCATION	PART NO.
Drive Shaft (Cont.)			Drive Shaft (Cont.)		
U-Joint (Cont.)			U-Joint (Cont.)		
1968-1967 Camaro w/o Turbo Hydramatic Trans.:			1961-1958 Nomad: [Type 2]		
[Type 1]			U-Joint (Front) ① UJ369		
U-Joint (Front) ① UJ369			Brute Force Greaseable UJ280		
Brute Force Greaseable UJ280			Brute Force Non Greaseable UJ269		
Brute Force Non Greaseable UJ269			(For Aluminum Drive Shaft) UJ369C		
(For Aluminum Drive Shaft) UJ369C			U-Bolt Kit (Front) UJ329-10		
U-Bolt Kit (Front) UJ329-10			U-Joint (Center) ② UJ369		
U-Joint (Rear) ② UJ369			Brute Force Greaseable UJ280		
Brute Force Greaseable UJ280			Brute Force Non Greaseable UJ269		
Brute Force Non Greaseable UJ269			(For Aluminum Drive Shaft) UJ369C		
(For Aluminum Drive Shaft) UJ369C			U-Bolt Kit (Center) UJ329-10		
U-Bolt Kit (Center) UJ329-10			U-Joint (Rear) ③ UJ369		
U-Bolt Kit (Rear) UJ329-10			Brute Force Greaseable UJ280		
1968-1967 Camaro w/ Turbo Hydramatic Trans.:			Brute Force Non Greaseable UJ269		
[Type 1]			(For Aluminum Drive Shaft) UJ369C		
U-Joint (Front) ① UJ534G			U-Bolt Kit (Rear) UJ329-10		
Brute Force Greaseable UJ235			1957-1955 Nomad: [Type 1]		
Brute Force Non Greaseable UJ234			U-Joint (Front) ① UJ369		
U-Joint (Rear) ② UJ355			Brute Force Greaseable UJ280		
Brute Force Greaseable UJ290			Brute Force Non Greaseable UJ269		
(For Aluminum Drive Shaft) UJ355C			(For Aluminum Drive Shaft) UJ369C		
1968-1967 Chevelle, El Camino & Malibu w/ Turbo Hydramatic Trans.: [Type 1]			U-Bolt Kit (Front) UJ329-10		
U-Joint (Front) ① UJ534G			U-Joint (Rear) ② UJ369		
Brute Force Greaseable UJ235			Brute Force Greaseable UJ280		
Brute Force Non Greaseable UJ234			Brute Force Non Greaseable UJ269		
U-Joint (Rear) ② UJ355			(For Aluminum Drive Shaft) UJ369C		
Brute Force Greaseable UJ290			U-Bolt Kit (Front) UJ329-10		
(For Aluminum Drive Shaft) UJ355C			U-Joint (Rear) ② UJ369		
1968-1967 Chevelle, El Camino & Malibu w/o Turbo Hydramatic Trans.: [Type 1]			Brute Force Greaseable UJ280		
U-Joint (Front) ① UJ369			Brute Force Non Greaseable UJ269		
Brute Force Greaseable UJ280			(For Aluminum Drive Shaft) UJ369C		
Brute Force Non Greaseable UJ269			U-Bolt Kit (Front) UJ329-10		
(For Aluminum Drive Shaft) UJ369C			U-Joint (Rear) ② UJ369		
U-Bolt Kit (Front) UJ329-10			Brute Force Greaseable UJ280		
U-Joint (Rear) ② UJ369			Brute Force Non Greaseable UJ269		
Brute Force Greaseable UJ280			(For Aluminum Drive Shaft) UJ369C		
Brute Force Non Greaseable UJ269			U-Bolt Kit (Rear) UJ329-10		
(For Aluminum Drive Shaft) UJ369C			1966-1964 Chevelle, El Camino & Malibu: [Type 1]		
U-Bolt Kit (Rear) UJ329-10			1]		
1966-1964 Chevelle, El Camino & Malibu: [Type 1]			U-Joint (Front) ① UJ369		
U-Joint (Front) ① UJ369			Brute Force Greaseable UJ280		
Brute Force Greaseable UJ280			Brute Force Non Greaseable UJ269		
Brute Force Non Greaseable UJ269			(For Aluminum Drive Shaft) UJ369C		
(For Aluminum Drive Shaft) UJ369C			U-Bolt Kit (Front) UJ329-10		
U-Bolt Kit (Front) UJ329-10			U-Joint (Rear) ② UJ369		
U-Joint (Rear) ② UJ369			Brute Force Greaseable UJ280		
Brute Force Greaseable UJ280			Brute Force Non Greaseable UJ269		
Brute Force Non Greaseable UJ269			(For Aluminum Drive Shaft) UJ369C		
(For Aluminum Drive Shaft) UJ369C			U-Bolt Kit (Rear) UJ329-10		
U-Bolt Kit (Rear) UJ329-10					

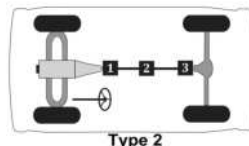
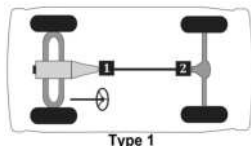

Passenger cars, light & medium trucks

Chevrolet (RWD) Chevette

MFG./YEAR	MODEL & LOCATION	PART NO.	MFG./YEAR	MODEL & LOCATION	PART NO.
Drive Shaft					
U-Joint					
1987-1976 All: [Type 1]					
	U-Joint (Front)Ⓢ	UJ368			
	Clamp Kit (Front)	UJ360-10			
	U-Joint (Rear)Ⓢ	UJ368			
	Clamp Kit (Rear)	UJ360-10			

Chevrolet (RWD) Corvair

Drive Shaft					
U-Joint					
1969-1960 Corvair: [Type 12]					
	U-Joint (Rear Half Shaft)Ⓢ	[4] UJ369			
	Brute Force Greaseable	UJ280			
	Brute Force Non Greaseable	UJ269			
	(For Aluminum Drive Shaft)	UJ369C			

Chevrolet (RWD) Corvette, Stingray

Drive Shaft			Drive Shaft (Cont.)		
U-Joint			U-Joint (Cont.)		
1996-1984 All: [Type 10]			1982-1980 Man. Trans.: [Type 10]		
	U-Joint (Front)Ⓢ	UJ369		U-Joint (Front)Ⓢ	UJ369
	Brute Force Greaseable	UJ280		Brute Force Greaseable	UJ280
	Brute Force Non Greaseable	UJ269		Brute Force Non Greaseable	UJ269
	(For Aluminum Drive Shaft)	UJ369C		(For Aluminum Drive Shaft)	UJ369C
	U-Joint (Rear)Ⓢ	UJ369		U-Joint (Rear)Ⓢ	UJ369
	Brute Force Greaseable	UJ280		Brute Force Greaseable	UJ280
	Brute Force Non Greaseable	UJ269		Brute Force Non Greaseable	UJ269
	(For Aluminum Drive Shaft)	UJ369C		(For Aluminum Drive Shaft)	UJ369C
	U-Joint (Rear Half Shaft)Ⓢ	[4] UJ231		U-Joint (Rear Half Shaft)Ⓢ	[4] UJ231
	(For Aluminum Drive Shaft)	UJ231C		(For Aluminum Drive Shaft)	UJ231C
1982-1980 Auto. Trans.: [Type 10]			1979-1971 All: [Type 10]		
	U-Joint (Front)Ⓢ	UJ354		U-Joint (Front)Ⓢ	UJ354
	Brute Force Greaseable	UJ270		Brute Force Greaseable	UJ270
	Brute Force Non Greaseable	UJ254		Brute Force Non Greaseable	UJ254
	(For Aluminum Drive Shaft)	UJ354C		(For Aluminum Drive Shaft)	UJ354C
	U-Joint (Rear)Ⓢ	UJ354		U-Joint (Rear)Ⓢ	UJ354
	Brute Force Greaseable	UJ270		Brute Force Greaseable	UJ270
	Brute Force Non Greaseable	UJ254		Brute Force Non Greaseable	UJ254
	(For Aluminum Drive Shaft)	UJ354C		(For Aluminum Drive Shaft)	UJ354C
	U-Joint (Rear Half Shaft)Ⓢ	[4] UJ231		U-Joint (Rear Half Shaft)Ⓢ	[4] UJ231
	(For Aluminum Drive Shaft)	UJ231C		(For Aluminum Drive Shaft)	UJ231C

(Continued)

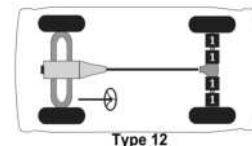
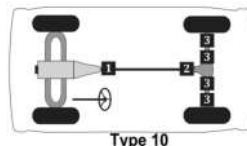
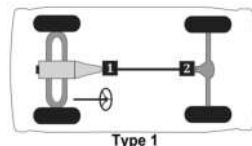

Passenger cars, light & medium trucks

Chevrolet (RWD) Corvette, Stingray -- (Cont.)

MFG./YEAR	MODEL & LOCATION	PART NO.	MFG./YEAR	MODEL & LOCATION	PART NO.
Drive Shaft (Cont.)			Drive Shaft (Cont.)		
U-Joint (Cont.)			U-Joint (Cont.)		
1970-1968 Auto. Trans.: [Type 10]			1967-1963 All: [Type 10]		
	U-Joint (Front) ①	UJ354		U-Joint (Front) ①	UJ369
	<i>Brute Force Greaseable</i>	UJ270		<i>Brute Force Greaseable</i>	UJ280
	<i>Brute Force Non Greaseable</i>	UJ254		<i>Brute Force Non Greaseable</i>	UJ269
	(For Aluminum Drive Shaft)	UJ354C		(For Aluminum Drive Shaft)	UJ369C
	U-Bolt Kit (Front)	UJ329-10		U-Bolt Kit (Front)	UJ329-10
	U-Joint (Rear) ②	UJ354		U-Joint (Rear) ②	UJ369
	<i>Brute Force Greaseable</i>	UJ270		<i>Brute Force Greaseable</i>	UJ280
	<i>Brute Force Non Greaseable</i>	UJ254		<i>Brute Force Non Greaseable</i>	UJ269
	(For Aluminum Drive Shaft)	UJ354C		(For Aluminum Drive Shaft)	UJ369C
	U-Bolt Kit (Rear)	UJ329-10		U-Bolt Kit (Rear)	UJ329-10
	U-Joint (Rear Half Shaft) ③	[4] UJ231		U-Joint (Rear Half Shaft) ③	[4] UJ231
	(For Aluminum Drive Shaft)	UJ231C		(For Aluminum Drive Shaft)	UJ231C
1970-1968 Man. Trans.: [Type 10]			1962-1953 All: [Type 1]		
	U-Joint (Front) ①	UJ369		U-Joint (Front) ①	UJ369
	<i>Brute Force Greaseable</i>	UJ280		<i>Brute Force Greaseable</i>	UJ280
	<i>Brute Force Non Greaseable</i>	UJ269		<i>Brute Force Non Greaseable</i>	UJ269
	(For Aluminum Drive Shaft)	UJ369C		(For Aluminum Drive Shaft)	UJ369C
	U-Bolt Kit (Front)	UJ329-10		U-Bolt Kit (Front)	UJ329-10
	U-Joint (Rear) ②	UJ369		U-Joint (Rear) ②	UJ369
	<i>Brute Force Greaseable</i>	UJ280		<i>Brute Force Greaseable</i>	UJ280
	<i>Brute Force Non Greaseable</i>	UJ269		<i>Brute Force Non Greaseable</i>	UJ269
	(For Aluminum Drive Shaft)	UJ369C		(For Aluminum Drive Shaft)	UJ369C
	U-Bolt Kit (Rear)	UJ329-10		U-Bolt Kit (Rear)	UJ329-10
	U-Joint (Rear Half Shaft) ③	[4] UJ231		U-Joint (Rear Half Shaft) ③	[4] UJ231
	(For Aluminum Drive Shaft)	UJ231C		(For Aluminum Drive Shaft)	UJ231C

Chevrolet (RWD) Monza, Vega

Drive Shaft	
U-Joint	
1980-1971 All: [Type 1]	
	U-Joint (Front) ①
	<i>Brute Force Greaseable</i>
	<i>Brute Force Non Greaseable</i>
	(For Aluminum Drive Shaft)
	U-Bolt Kit (Front)
	U-Joint (Rear) ②
	<i>Brute Force Greaseable</i>
	<i>Brute Force Non Greaseable</i>
	(For Aluminum Drive Shaft)
	U-Bolt Kit (Rear)

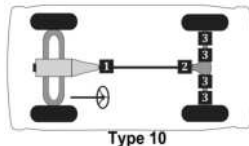
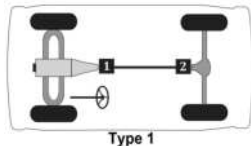

Passenger cars, light & medium trucks

Chrysler (FWD) Town & Country, Voyager

MFG./YEAR	MODEL & LOCATION	PART NO.	MFG./YEAR	MODEL & LOCATION	PART NO.
-----------	------------------	----------	-----------	------------------	----------

Drive Shaft

U-Joint

2004-2001 Town & Country:

Flex CouplerVKJF98017

Chrysler (RWD) (Full Size-exc. Imperial), Conquest (from 1987), Cordoba, Fifth Avenue, LeBaron (thru 1981), Newport, New Yorker (thru 1982), Town & Country (thru 1982), Windsor, 300 (thru 1971)

Drive Shaft

U-Joint

1989-1987 Fifth Avenue: [Type 1]

U-Joint (Front)⓪UJ317

Brute Force GreaseableUJ246

Clamp Kit (Front)UJ318-10

U-Joint (Rear)⓪UJ317

Brute Force GreaseableUJ246

Clamp Kit (Rear)UJ318-10

1989-1987 Conquest : [Type 1]

U-Joint (Front)⓪UJ399

U-Joint (Rear)⓪UJ399

1986-1979 Cordoba, Fifth Avenue, New Yorker,
Newport & Valiant: [Type 1]

U-Joint (Front)⓪UJ315G

Brute Force GreaseableUJ246

Clamp Kit (Front)UJ318-10

U-Joint (Rear)⓪UJ315G

Brute Force GreaseableUJ246

Clamp Kit (Rear)UJ318-10

1981-1979 LeBaron: [Type 1]

U-Joint (Front)⓪UJ315G

Brute Force GreaseableUJ246

Clamp Kit (Front)UJ318-10

U-Joint (Rear)⓪UJ315G

Brute Force GreaseableUJ246

Clamp Kit (Rear)UJ318-10

1978-1968 Cordoba, LeBaron, New Yorker,
Newport & Valiant w/ 2.125" Yoke:
[Type 1]

U-Joint (Front)⓪UJ315G

Brute Force GreaseableUJ246

Clamp Kit (Front)UJ318-10

U-Joint (Rear)⓪UJ315G

Brute Force GreaseableUJ246

Clamp Kit (Rear)UJ318-10

1978-1968 Cordoba, LeBaron, New Yorker,
Newport & Valiant w/ 2.625" Yoke:
[Type 1]

U-Joint (Front)⓪UJ316

Brute Force GreaseableUJ248

Clamp Kit (Front)UJ316-10

U-Joint (Rear)⓪UJ316

Brute Force GreaseableUJ248

Clamp Kit (Rear)UJ316-10

Drive Shaft (Cont.)

U-Joint (Cont.)

1967 New Yorker, Newport, Town and
Country & 300 w/ Outer Lock Rings:
[Type 1]

U-Joint (Front)⓪UJ354

Brute Force GreaseableUJ270

Brute Force Non GreaseableUJ254

(For Aluminum Drive Shaft)UJ354C

U-Joint (Rear)⓪UJ354

Brute Force GreaseableUJ270

Brute Force Non GreaseableUJ254

(For Aluminum Drive Shaft)UJ354C

1967 New Yorker, Newport, Town and
Country & 300 w/ Inner Lock Rings:
[Type 1]

U-Joint (Front)⓪UJ315G

Brute Force GreaseableUJ246

U-Joint (Rear)⓪UJ315G

Brute Force GreaseableUJ246

1966-1965 Newport, Town and Country & 300 w/
Inner Lock Rings: [Type 1]

U-Joint (Front)⓪UJ315G

Brute Force GreaseableUJ246

U-Joint (Rear)⓪UJ315G

Brute Force GreaseableUJ246

1966-1965 New Yorker: [Type 1]

U-Joint (Front)⓪UJ354

Brute Force GreaseableUJ270

Brute Force Non GreaseableUJ254

(For Aluminum Drive Shaft)UJ354C

U-Joint (Rear)⓪UJ315G

Brute Force GreaseableUJ246

(Continued)

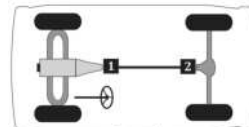

Passenger cars, light & medium trucks

Chrysler (RWD) (Full Size-exc. Imperial), Conquest (from 1987), Cordoba, Fifth Avenue, LeBaron (thru 1981), Newport, New Yorker (thru 1982), Town & Country (thru 1982), Windsor, 300 (thru 1971) -- (Cont.)

MFG./YEAR	MODEL & LOCATION	PART NO.	MFG./YEAR	MODEL & LOCATION	PART NO.
Drive Shaft (Cont.)					
U-Joint (Cont.)					
1966-1965 Newport, Town and Country & 300 w/ Outer Lock Rings: [Type 1]					
	U-Joint (Front)Ⓛ	UJ354			
	Brute Force Greaseable	UJ270			
	Brute Force Non Greaseable	UJ254			
	(For Aluminum Drive Shaft)	UJ354C			
	U-Joint (Rear)Ⓢ	UJ354			
	Brute Force Greaseable	UJ270			
	Brute Force Non Greaseable	UJ254			
	(For Aluminum Drive Shaft)	UJ354C			
1964-1958 New Yorker, Newport, Town and Country, 300 & Windsor: [Type 7]					
	U-Joint (Rear)Ⓢ	UJ315G			
	Brute Force Greaseable	UJ246			

Chrysler (RWD) Imperial (thru 1983)

Drive Shaft		
U-Joint		
1975-1974 All: [Type 1]		
	U-Joint (Front)Ⓛ	UJ316
	Brute Force Greaseable	UJ248
	Clamp Kit (Front)	UJ316-10
	U-Joint (Rear)Ⓢ	UJ316
	Brute Force Greaseable	UJ248
	Clamp Kit (Rear)	UJ316-10
1973-1970 w/ Inner Lock Rings: [Type 1]		
	U-Joint (Front)Ⓛ	UJ316
	Brute Force Greaseable	UJ248
	Clamp Kit (Front)	UJ316-10
	U-Joint (Rear)Ⓢ	UJ316
	Brute Force Greaseable	UJ248
	Clamp Kit (Rear)	UJ316-10
1973-1970 w/ Outer Lock Rings: [Type 1]		
	U-Joint (Front)Ⓛ	UJ354
	Brute Force Greaseable	UJ270
	Brute Force Non Greaseable	UJ254
	(For Aluminum Drive Shaft)	UJ354C
	U-Joint (Rear)Ⓢ	UJ354
	Brute Force Greaseable	UJ270
	Brute Force Non Greaseable	UJ254
	(For Aluminum Drive Shaft)	UJ354C

Drive Shaft (Cont.)		
U-Joint (Cont.)		
1969-1965 All: [Type 1]		
	U-Joint (Front)Ⓛ	UJ354
	Brute Force Greaseable	UJ270
	Brute Force Non Greaseable	UJ254
	(For Aluminum Drive Shaft)	UJ354C
	U-Joint (Rear)Ⓢ	UJ354
	Brute Force Greaseable	UJ270
	Brute Force Non Greaseable	UJ254
	(For Aluminum Drive Shaft)	UJ354C
1964-1960 All: [Type 1]		
	U-Joint (Front)Ⓛ	UJ315G
	Brute Force Greaseable	UJ246
	U-Joint (Rear)Ⓢ	UJ315G
	Brute Force Greaseable	UJ246
1959 2 Joint Shaft: [Type 1]		
	U-Joint (Front)Ⓛ	UJ315G
	Brute Force Greaseable	UJ246
	U-Joint (Rear)Ⓢ	UJ315G
	Brute Force Greaseable	UJ246
1959 3 Joint Shaft: [Type 6]		
	U-Joint (Center)Ⓛ	UJ315G
	Brute Force Greaseable	UJ246
	U-Joint (Rear)Ⓢ	UJ315G
	Brute Force Greaseable	UJ246
1958 All: [Type 6]		
	U-Joint (Center)Ⓛ	UJ315G
	Brute Force Greaseable	UJ246
	U-Joint (Rear)Ⓢ	UJ315G
	Brute Force Greaseable	UJ246

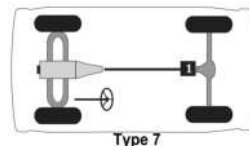
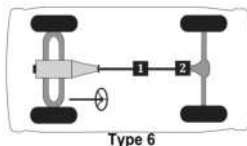
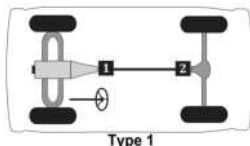

Passenger cars, light & medium trucks

Chrysler (RWD) 300, 300C, 300S

MFG./YEAR	MODEL & LOCATION	PART NO.	MFG./YEAR	MODEL & LOCATION	PART NO.
Drive Shaft					
U-Joint					
2011-2005 300 w/ 5.7L Eng.:					
	Flex Coupler	VKJF98016			
2011-2005 300C:					
	Flex Coupler	VKJF98015			
2010-2005 300 w/ 3.5L Eng.:					
	Flex Coupler	VKJF98015			

Daihatsu Rocky

Drive Shaft (4 W/D)					
U-Joint					
1992-1990 Rocky: [Type 17]					
	U-Joint (Rr. Shaft; Frt.)ⓐ	UJ450			
	U-Joint (Rr. Shaft; Rr.)ⓑ	UJ450			

Dodge (FWD) Avenger

Drive Shaft					
U-Joint					
2008 Avenger:					
	Flex Coupler	VKJF98014			

Dodge (FWD) Caravan, Grand Caravan, Mini Ram Van, Royal Ram Van

Drive Shaft					
U-Joint					
2004-2001 Grand Caravan:					
	Flex Coupler	VKJF98017			

Dodge (RWD) Challenger (from 1978), Colt (thru 1979), Conquest (thru 1986)

Drive Shaft					
U-Joint					
1986-1984 Conquest: [Type 1]					
	U-Joint (Front)ⓐ	UJ399			
	U-Joint (Rear)ⓑ	UJ399			
1983-1981 Challenger w/ Auto Trans.: [Type 2]					
	U-Joint (Front)ⓐ	UJ398			
	U-Joint (Center)ⓑ	UJ398			
	U-Joint (Rear)ⓒ	UJ398			
1983-1981 Challenger w/ Man. Trans.: [Type 2]					
	U-Joint (Front)ⓐ	UJ399			
	U-Joint (Center)ⓑ	UJ399			
	U-Joint (Rear)ⓒ	UJ399			
1980-1978 Challenger: [Type 1]					
	U-Joint (Front)ⓐ	UJ399			
	U-Joint (Rear)ⓑ	UJ399			

Drive Shaft (Cont.)					
U-Joint (Cont.)					
1980-1978 Colt Wgn.: [Type 1]					
	U-Joint (Front)ⓐ	UJ399			
	U-Joint (Rear)ⓑ	UJ399			
1979-1978 Colt Sedan: [Type 1]					
	U-Joint (Front)ⓐ	UJ398			
	U-Joint (Rear)ⓑ	UJ398			
1977-1971 Colt: [Type 1]					
	U-Joint (Front)ⓐ	UJ398			
	U-Joint (Rear)ⓑ	UJ398			

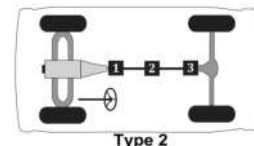
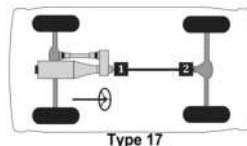
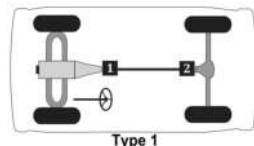

Passenger cars, light & medium trucks

Dodge (RWD) Aspen, Challenger (thru 1974), Dart

MFG./YEAR	MODEL & LOCATION	PART NO.
Drive Shaft		
U-Joint		
1980-1976 Aspen: [Type 1]		
U-Joint (Front)Ⓚ		UJ315G
Brute Force Greaseable		UJ246
Clamp Kit (Front)		UJ318-10
U-Joint (Rear)Ⓚ		UJ315G
Brute Force Greaseable		UJ246
Clamp Kit (Rear)		UJ318-10
1975-1970 Dart: [Type 1]		
U-Joint (Front)Ⓚ		UJ315G
Brute Force Greaseable		UJ246
Clamp Kit (Front)		UJ318-10
U-Joint (Rear)Ⓚ		UJ315G
Brute Force Greaseable		UJ246
Clamp Kit (Rear)		UJ318-10
1974-1972 Challenger: [Type 1]		
U-Joint (Front)Ⓚ		UJ315G
Brute Force Greaseable		UJ246
Clamp Kit (Front)		UJ318-10
U-Joint (Rear)Ⓚ		UJ315G
Brute Force Greaseable		UJ246
Clamp Kit (Rear)		UJ318-10
1971-1970 Challenger w/ 2.125" Yoke: [Type 1]		
U-Joint (Front)Ⓚ		UJ315G
Brute Force Greaseable		UJ246
Clamp Kit (Front)		UJ318-10
U-Joint (Rear)Ⓚ		UJ315G
Brute Force Greaseable		UJ246
Clamp Kit (Rear)		UJ318-10
1971-1970 Challenger w/ 2.625" Yoke: [Type 1]		
U-Joint (Front)Ⓚ		UJ316
Brute Force Greaseable		UJ248
Clamp Kit (Front)		UJ316-10
U-Joint (Rear)Ⓚ		UJ316
Brute Force Greaseable		UJ248
Clamp Kit (Rear)		UJ316-10

Drive Shaft (Cont.)

U-Joint (Cont.)		
1969-1968 Dart w/ 2.125" Yoke: [Type 1]		
U-Joint (Front)Ⓚ		UJ315G
Brute Force Greaseable		UJ246
Clamp Kit (Front)		UJ318-10
U-Joint (Rear)Ⓚ		UJ315G
Brute Force Greaseable		UJ246
Clamp Kit (Rear)		UJ318-10
1969-1968 Dart w/ 2.625" Yoke: [Type 1]		
U-Joint (Front)Ⓚ		UJ316
Brute Force Greaseable		UJ248
U-Joint (Rear)Ⓚ		UJ316
Brute Force Greaseable		UJ248
1967-1966 Dart: [Type 1]		
U-Joint (Front)Ⓚ		UJ315G
Brute Force Greaseable		UJ246
Clamp Kit (Front)		UJ318-10
U-Joint (Rear)Ⓚ		UJ315G
Brute Force Greaseable		UJ246
Clamp Kit (Rear)		UJ318-10
1965-1960 Dart: [Type 7]		
U-Joint (Rear)Ⓚ		UJ315G
Brute Force Greaseable		UJ246
Clamp Kit (Rear)		UJ318-10

Dodge (RWD) Charger (thru 1978), Coronet, Custom, Diplomat, Magnum, Mirada, Monaco (thru 1978), Polara, Royal Monaco, St. Regis

Drive Shaft		
U-Joint		
1989-1986 Diplomat: [Type 1]		
U-Joint (Front)Ⓚ		UJ317
Brute Force Greaseable		UJ246
Clamp Kit (Front)		UJ318-10
U-Joint (Rear)Ⓚ		UJ317
Brute Force Greaseable		UJ246
Clamp Kit (Rear)		UJ318-10

Drive Shaft (Cont.)

U-Joint (Cont.)		
1985-1977 Diplomat, Mirada & St. Regis: [Type 1]		
U-Joint (Front)Ⓚ		UJ315G
Brute Force Greaseable		UJ246
Clamp Kit (Front)		UJ318-10
U-Joint (Rear)Ⓚ		UJ315G
Brute Force Greaseable		UJ246
Clamp Kit (Rear)		UJ318-10

(Continued)

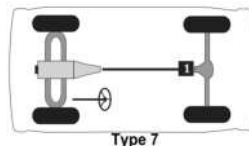
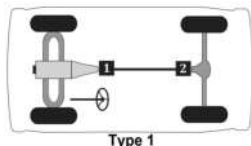

Passenger cars, light & medium trucks

(Cont.) -- Dodge (RWD) Charger (thru 1978), Coronet, Custom, Diplomat, Magnum, Mirada, Monaco (thru 1978), Polara, Royal Monaco, St. Regis

MFG./YEAR	MODEL & LOCATION	PART NO.	MFG./YEAR	MODEL & LOCATION	PART NO.
Drive Shaft (Cont.)			Drive Shaft (Cont.)		
U-Joint (Cont.)			U-Joint (Cont.)		
1979	Magnum: [Type 1]		1967-1966	Monaco w/ 440 Eng. & Inner Lock Rings: [Type 1]	
	U-Joint (Front) ①	UJ315G		U-Joint (Front) ①	UJ316
	Brute Force Greaseable	UJ246		Brute Force Greaseable	UJ248
	Clamp Kit (Front)	UJ318-10		Clamp Kit (Front)	UJ316-10
	U-Joint (Rear) ②	UJ315G		U-Joint (Rear) ②	UJ316
	Brute Force Greaseable	UJ246		Brute Force Greaseable	UJ248
	Clamp Kit (Rear)	UJ318-10		Clamp Kit (Rear)	UJ316-10
1978-1968	Charger, Coronet, Magnum, Monaco, Polara & Royal Monaco w/ 2.125" Yoke: [Type 1]		1967-1966	Charger, Coronet & Polara w/ 426 & 440 Engs. & Outer Lock Rings: [Type 1]	
	U-Joint (Front) ①	UJ315G		U-Joint (Front) ①	UJ354
	Brute Force Greaseable	UJ246		Brute Force Greaseable	UJ270
	Clamp Kit (Front)	UJ318-10		Brute Force Non Greaseable	UJ254
	U-Joint (Rear) ②	UJ315G		(For Aluminum Drive Shaft)	UJ354C
	Brute Force Greaseable	UJ246		U-Joint (Rear) ②	UJ354
	Clamp Kit (Rear)	UJ318-10		Brute Force Greaseable	UJ270
1978-1968	Charger, Coronet, Magnum, Monaco, Polara & Royal Monaco w/ 2.625" Yoke: [Type 1]			Brute Force Non Greaseable	UJ254
	U-Joint (Front) ①	UJ316		(For Aluminum Drive Shaft)	UJ354C
	Brute Force Greaseable	UJ248	1967-1966	Monaco w/ 440 Eng. & Outer Lock Rings: [Type 1]	
	Clamp Kit (Front)	UJ316-10		U-Joint (Front) ①	UJ354
	U-Joint (Rear) ②	UJ316		Brute Force Greaseable	UJ270
	Brute Force Greaseable	UJ248		Brute Force Non Greaseable	UJ254
	Clamp Kit (Rear)	UJ316-10		(For Aluminum Drive Shaft)	UJ354C
1967-1966	Charger, Coronet & Polara w/ 225, 273, 318 & 383 Engs.: [Type 1]			U-Joint (Rear) ②	UJ354
	U-Joint (Front) ①	UJ315G		Brute Force Greaseable	UJ270
	Brute Force Greaseable	UJ246		Brute Force Non Greaseable	UJ254
	Clamp Kit (Front)	UJ318-10		(For Aluminum Drive Shaft)	UJ354C
	U-Joint (Rear) ②	UJ315G	1965	Coronet, Custom & Polara w/ 318, 361, 383 & 426 Engs. & Auto Trans.: [Type 1]	
	Brute Force Greaseable	UJ246		U-Joint (Front) ①	UJ315G
	Clamp Kit (Rear)	UJ318-10		Brute Force Greaseable	UJ246
1967-1966	Charger, Coronet & Polara w/ 426 & 440 Engs. & Inner Lock Rings: [Type 1]			Clamp Kit (Front)	UJ318-10
	U-Joint (Front) ①	UJ316		U-Joint (Rear) ②	UJ315G
	Brute Force Greaseable	UJ248		Brute Force Greaseable	UJ246
	Clamp Kit (Front)	UJ316-10		Clamp Kit (Rear)	UJ318-10
	U-Joint (Rear) ②	UJ316	1965	Coronet, Custom & Polara w/ 318, 361, 383 & 426 Engs. & Man. Trans.: [Type 7]	
	Brute Force Greaseable	UJ248		U-Joint (Rear) ①	UJ315G
	Clamp Kit (Rear)	UJ316-10		Brute Force Greaseable	UJ246
1967-1966	Monaco w/ 383 Eng.: [Type 1]			Clamp Kit (Rear)	UJ318-10
	U-Joint (Front) ①	UJ315G			
	Brute Force Greaseable	UJ246			
	Clamp Kit (Front)	UJ318-10			
	U-Joint (Rear) ②	UJ315G			
	Brute Force Greaseable	UJ246			
	Clamp Kit (Rear)	UJ318-10			

(Continued)

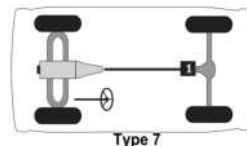
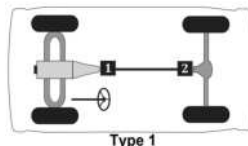

Passenger cars, light & medium trucks

Dodge (RWD) Charger (thru 1978), Coronet, Custom, Diplomat, Magnum, Mirada, Monaco (thru 1978), Polara, Royal Monaco, St. Regis -- (Cont.)

MFG./YEAR	MODEL & LOCATION	PART NO.	MFG./YEAR	MODEL & LOCATION	PART NO.
Drive Shaft (Cont.)			Drive Shaft (Cont.)		
U-Joint (Cont.)			U-Joint (Cont.)		
1965	Coronet, Custom & Polara w/ 225 & 273 Eng.: [Type 1]		1964-1958	Coronet, Custom, Polara & 880: [Type 7]	
	U-Joint (Front)Ⓚ	UJ315G		U-Joint (Rear)Ⓚ	UJ315G
	Brute Force Greaseable	UJ246		Brute Force Greaseable	UJ246
	Clamp Kit (Front)	UJ318-10		Clamp Kit (Rear)	UJ318-10
	U-Joint (Rear)Ⓚ	UJ315G			
	Brute Force Greaseable	UJ246			
	Clamp Kit (Rear)	UJ318-10			
1965	Monaco w/ Auto Trans.: [Type 1]				
	U-Joint (Front)Ⓚ	UJ315G			
	Brute Force Greaseable	UJ246			
	Clamp Kit (Front)	UJ318-10			
	U-Joint (Rear)Ⓚ	UJ315G			
	Brute Force Greaseable	UJ246			
	Clamp Kit (Rear)	UJ318-10			

Dodge (RWD) Charger, Challenger, Magnum

Drive Shaft	
U-Joint	
2014-2012 Challenger & Charger:	
Flex Coupler	VKJF98019
2011-2009 Challenger:	
Flex Coupler	VKJF98016
2011-2006 Charger:	
Flex Coupler	VKJF98016
2011-2006 Charger SRT8 w/ 6.1L Eng.:	
Flex Coupler	VKJF98018 [2]
2008-2005 Magnum w/ 5.7L Eng.:	
Flex Coupler	VKJF98016

Dodge (RWD) Viper

Drive Shaft	Drive Shaft (Cont.)
U-Joint	
2017-2015 All: [Type 1]	
U-Joint (Front)Ⓚ	UJ331
Brute Force Greaseable	UJ232
Brute Force Non Greaseable	UJ231
(For Aluminum Drive Shaft)	UJ331C
U-Joint (Rear)Ⓚ	UJ331
Brute Force Greaseable	UJ232
Brute Force Non Greaseable	UJ231
(For Aluminum Drive Shaft)	UJ331C
2010-2003 All: [Type 1]	
U-Joint (Front)Ⓚ	UJ231
(For Aluminum Drive Shaft)	UJ231C
U-Joint (Rear)Ⓚ	UJ231
(For Aluminum Drive Shaft)	UJ231C
U-Joint (Cont.)	
2002-1992 All: [Type 8]	
U-Joint (Front)Ⓚ	UJ231
(For Aluminum Drive Shaft)	UJ231C
U-Joint (Rear)Ⓚ	UJ231
(For Aluminum Drive Shaft)	UJ231C
U-Joint (Rear Half Shaft)Ⓚ	UJ231 [2]
(For Aluminum Drive Shaft)	UJ231C

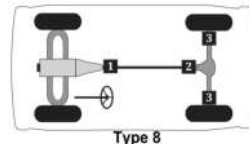
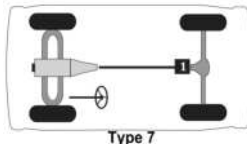
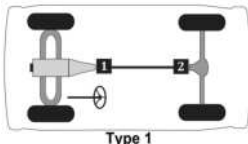

Passenger cars, light & medium trucks

Dodge CUV Journey

MFG./YEAR	MODEL & LOCATION	PART NO.	MFG./YEAR	MODEL & LOCATION	PART NO.
-----------	------------------	----------	-----------	------------------	----------

Drive Shaft

U-Joint

2017-2009 Journey:

Flex CouplerVKJF98014

Eagle Talon

Drive Shaft

U-Joint

1995-1990 AWD: [Type 42]

U-Joint (Front)ⓁUJ398

U-Joint (Center)ⓂUJ398

U-Joint (Rear)ⓎUJ398

Eagle (Canada) Vista, 2000GTX

Drive Shaft

U-Joint

1992-1989 AWD: [Type 42]

U-Joint (Front)ⓁUJ398

U-Joint (Center)ⓂUJ398

U-Joint (Rear)ⓎUJ398

Edsel

Drive Shaft

U-Joint

1960-1958 All: [Type 1]

U-Joint (Front)ⓁUJ369

Brute Force GreaseableUJ280

Brute Force Non GreaseableUJ269

(For Aluminum Drive Shaft)UJ369C

U-Joint (Rear)ⓎUJ369

Brute Force GreaseableUJ280

Brute Force Non GreaseableUJ269

(For Aluminum Drive Shaft)UJ369C

Fiat (RWD) US & Canada, Brava, 124, 131

Drive Shaft

U-Joint

1983-1966 124 Spider, 131 & Brava: [Type 6]

U-Joint (Center)ⓂUJ341

U-Joint (Rear)ⓎUJ341

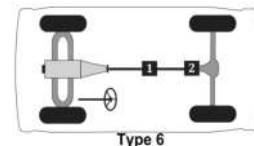
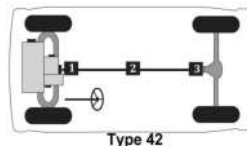
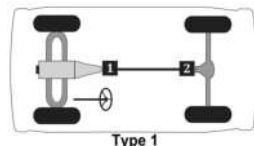

Passenger cars, light & medium trucks

Ford (FWD) Tempo

MFG./YEAR	MODEL & LOCATION	PART NO.	MFG./YEAR	MODEL & LOCATION	PART NO.
Drive Shaft					
U-Joint					
1991-1987 Tempo w/ AWD: [Type 45]					
	U-Joint (Front)Ⓛ	UJ437G			
	Brute Force Greaseable	UJ240			
	Brute Force Non Greaseable	UJ237			
	Clamp Kit (Front)	UJ437-10			
	U-Joint (Center)Ⓛ	UJ437G			
	Brute Force Greaseable	UJ240			
	Brute Force Non Greaseable	UJ237			
	Clamp Kit (Center)	UJ437-10			
	U-Joint (Rear)Ⓛ	UJ437G			
	Brute Force Greaseable	UJ240			
	Brute Force Non Greaseable	UJ237			
	Clamp Kit (Rear)	UJ437-10			
	U-Joint (Rear Half Shaft)Ⓛ	[2] UJ237			

Ford (RWD) (Full Size), Country Sedan, Country Squire, Crown Victoria, Custom, Fairlane (1955-1961), Galaxie, LTD (thru 1982)

MFG./YEAR	MODEL & LOCATION	PART NO.	MFG./YEAR	MODEL & LOCATION	PART NO.
Drive Shaft			Drive Shaft (Cont.)		
U-Joint			U-Joint (Cont.)		
2011-2006 Crown Victoria From 6/19/06: [Type 1]			2002-1995 Crown Victoria: [Type 1]		
	U-Joint (Front)Ⓛ	UJ331		U-Joint (Front)Ⓛ	UJ354
	Brute Force Greaseable	UJ232		Brute Force Greaseable	UJ270
	Brute Force Non Greaseable	UJ231		Brute Force Non Greaseable	UJ254
	(For Aluminum Drive Shaft)	UJ331C		(For Aluminum Drive Shaft)	UJ354C
	U-Joint (Rear)Ⓛ	UJ331		U-Joint (Rear)Ⓛ	UJ354
	Brute Force Greaseable	UJ232		Brute Force Greaseable	UJ270
	Brute Force Non Greaseable	UJ231		Brute Force Non Greaseable	UJ254
	(For Aluminum Drive Shaft)	UJ331C		(For Aluminum Drive Shaft)	UJ354C
2006-2003 Crown Victoria Thru 6/18/06 w/ Alum. Driveshaft & 1.063" O.D. Brg. Cap: [Type 1]			1994-1987 Crown Victoria & Country Squire w/ 3.5" Yoke: [Type 1]		
	U-Joint (Front)Ⓛ	UJ354C		U-Joint (Front)Ⓛ	UJ369
	U-Joint (Rear)Ⓛ	UJ354C		Brute Force Greaseable	UJ280
				Brute Force Non Greaseable	UJ269
				(For Aluminum Drive Shaft)	UJ369C
2006-2003 Crown Victoria Thru 6/18/06 w/ Alum. Driveshaft & 1.188" O.D. Brg. Cap: [Type 1]				U-Joint (Rear)Ⓛ	UJ369
	U-Joint (Front)Ⓛ	UJ331C		Brute Force Greaseable	UJ280
	U-Joint (Rear)Ⓛ	UJ331C		Brute Force Non Greaseable	UJ269
				(For Aluminum Drive Shaft)	UJ369C
2006-2003 Crown Victoria Thru 6/18/06 w/ Steel Driveshaft: [Type 1]			1994-1987 Crown Victoria & Country Squire w/ 3.875" Yoke: [Type 1]		
	U-Joint (Front)Ⓛ	UJ345		U-Joint (Front)Ⓛ	UJ354
	U-Joint (Rear)Ⓛ	UJ345		Brute Force Greaseable	UJ270
				Brute Force Non Greaseable	UJ254
				(For Aluminum Drive Shaft)	UJ354C
				U-Joint (Rear)Ⓛ	UJ354
				Brute Force Greaseable	UJ270
				Brute Force Non Greaseable	UJ254
				(For Aluminum Drive Shaft)	UJ354C

(Continued)

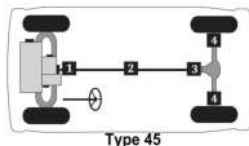
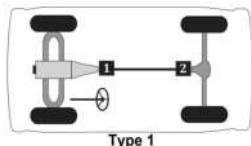

Passenger cars, light & medium trucks

(Cont.) -- Ford (RWD) (Full Size), Country Sedan, Country Squire, Crown Victoria, Custom, Fairlane (1955-1961), Galaxie, LTD (thru 1982)

MFG./YEAR	MODEL & LOCATION	PART NO.	MFG./YEAR	MODEL & LOCATION	PART NO.
Drive Shaft (Cont.)			Drive Shaft (Cont.)		
U-Joint (Cont.)			U-Joint (Cont.)		
1982-1979 LTD w/ 3.5" Yoke: [Type 1]			1974-1966 Country Sedan, Country Squire, Custom & LTD w/ 3.5" Yoke: [Type 1]		
	U-Joint (Front) ①	UJ369		U-Joint (Front) ①	UJ369
	Brute Force Greaseable	UJ280		Brute Force Greaseable	UJ280
	Brute Force Non Greaseable	UJ269		Brute Force Non Greaseable	UJ269
	(For Aluminum Drive Shaft)	UJ369C		(For Aluminum Drive Shaft)	UJ369C
	U-Joint (Rear) ②	UJ369		U-Joint (Rear) ②	UJ430
	Brute Force Greaseable	UJ280		Brute Force Greaseable	UJ255
	Brute Force Non Greaseable	UJ269		U-Bolt Kit (Rear)	UJ534-10
	(For Aluminum Drive Shaft)	UJ369C	1974-1966 Galaxie w/ 3.5" Yoke: [Type 1]		
1982-1979 LTD w/ 3.875" Yoke: [Type 1]				U-Joint (Front) ①	UJ369
	U-Joint (Front) ①	UJ354		Brute Force Greaseable	UJ280
	Brute Force Greaseable	UJ270		Brute Force Non Greaseable	UJ269
	Brute Force Non Greaseable	UJ254		(For Aluminum Drive Shaft)	UJ369C
	(For Aluminum Drive Shaft)	UJ354C		U-Joint (Rear) ②	UJ430
	U-Joint (Rear) ②	UJ354		Brute Force Greaseable	UJ255
	Brute Force Greaseable	UJ270	1974-1966 Country Sedan, Country Squire, Custom & LTD w/ 3.875" Yoke: [Type 1]		
	Brute Force Non Greaseable	UJ254		U-Joint (Front) ①	UJ354
	(For Aluminum Drive Shaft)	UJ354C		Brute Force Greaseable	UJ270
1978 LTD w/ 302 Eng.: [Type 1]				Brute Force Non Greaseable	UJ254
	U-Joint (Front) ①	UJ369		(For Aluminum Drive Shaft)	UJ369C
	Brute Force Greaseable	UJ280		U-Joint (Rear) ②	UJ430
	Brute Force Non Greaseable	UJ269		Brute Force Greaseable	UJ255
	(For Aluminum Drive Shaft)	UJ369C		U-Bolt Kit (Rear)	UJ534-10
	U-Joint (Rear) ②	UJ430	1974-1966 Galaxie w/ 3.875" Yoke: [Type 1]		
	Brute Force Greaseable	UJ255		U-Joint (Front) ①	UJ354
1978-1975 LTD w/ 351 Eng. & 3.5" Yoke: [Type 1]				Brute Force Greaseable	UJ270
	U-Joint (Front) ①	UJ369		Brute Force Non Greaseable	UJ254
	Brute Force Greaseable	UJ280		(For Aluminum Drive Shaft)	UJ369C
	Brute Force Non Greaseable	UJ269		U-Joint (Rear) ②	UJ430
	(For Aluminum Drive Shaft)	UJ369C		Brute Force Greaseable	UJ255
	U-Joint (Rear) ②	UJ430		U-Bolt Kit (Rear)	UJ534-10
	Brute Force Greaseable	UJ255	1978-1975 LTD w/ 400 & 460 Eng.: [Type 1]		
	U-Bolt Kit (Rear)	UJ534-10		U-Joint (Front) ①	UJ354
1978-1975 LTD w/ 400 & 460 Eng.: [Type 1]				Brute Force Greaseable	UJ270
	U-Joint (Front) ①	UJ354		Brute Force Non Greaseable	UJ254
	Brute Force Greaseable	UJ270		(For Aluminum Drive Shaft)	UJ354C
	Brute Force Non Greaseable	UJ254		U-Joint (Rear) ②	UJ430
	(For Aluminum Drive Shaft)	UJ354C		Brute Force Greaseable	UJ265
	U-Joint (Rear) ②	UJ430		Brute Force Non Greaseable	UJ264
	Brute Force Greaseable	UJ265		U-Bolt Kit (Rear)	UJ534-10
	Brute Force Non Greaseable	UJ264	1978-1975 LTD w/ 351 Eng. & 3.875" Yoke: [Type 1]		
	U-Bolt Kit (Rear)	UJ534-10		U-Joint (Front) ①	UJ354
1978-1975 LTD w/ 351 Eng. & 3.875" Yoke: [Type 1]				Brute Force Greaseable	UJ270
	U-Joint (Front) ①	UJ354		Brute Force Non Greaseable	UJ254
	Brute Force Greaseable	UJ270		(For Aluminum Drive Shaft)	UJ354C
	Brute Force Non Greaseable	UJ254		U-Joint (Rear) ②	UJ430
	(For Aluminum Drive Shaft)	UJ354C		Brute Force Greaseable	UJ265
	U-Joint (Rear) ②	UJ430		Brute Force Non Greaseable	UJ264
	Brute Force Greaseable	UJ265		U-Bolt Kit (Rear)	UJ534-10
	Brute Force Non Greaseable	UJ264	1965-1963 Country Sedan, Country Squire, Custom & LTD w/ 170, 200, 223 & 240 Eng.: [Type 1]		
	U-Bolt Kit (Rear)	UJ534-10		U-Joint (Front) ①	UJ430
1978-1975 LTD w/ 351 Eng. & 3.875" Yoke: [Type 1]				Brute Force Greaseable	UJ260
	U-Joint (Front) ①	UJ354		U-Joint (Rear) ②	UJ430
	Brute Force Greaseable	UJ270		Brute Force Greaseable	UJ265
	Brute Force Non Greaseable	UJ254		Brute Force Non Greaseable	UJ264
	(For Aluminum Drive Shaft)	UJ354C		U-Bolt Kit (Rear)	UJ534-10
	U-Joint (Rear) ②	UJ430	1965-1963 Country Sedan, Country Squire, Custom & LTD w/ 170, 200, 223 & 240 Eng.: [Type 1]		
	Brute Force Greaseable	UJ265		U-Joint (Front) ①	UJ429
	Brute Force Non Greaseable	UJ264		Brute Force Greaseable	UJ250
	U-Bolt Kit (Rear)	UJ534-10		U-Joint (Rear) ②	UJ430
				Brute Force Greaseable	UJ255
				U-Bolt Kit (Rear)	UJ534-10

(Continued)

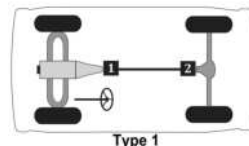

Type 1

Passenger cars, light & medium trucks

Ford (RWD) (Full Size), Country Sedan, Country Squire, Crown Victoria, Custom, Fairlane (1955-1961), Galaxie, LTD (thru 1982) -- (Cont.)

MFG./YEAR	MODEL & LOCATION	PART NO.	MFG./YEAR	MODEL & LOCATION	PART NO.
Drive Shaft (Cont.)			Drive Shaft (Cont.)		
U-Joint (Cont.)			U-Joint (Cont.)		
1965-1963 Country Sedan, Country Squire, Custom & LTD w/ 221, 260, 289 & 352 Eng.: [Type 1]			1960-1959 Country Sedan, Country Squire & Fairlane w/ Inner Lock Rings: [Type 1]		
	U-Joint (Front) ①	UJ429		U-Joint (Front) ①	UJ507
	Brute Force Greaseable	UJ250		U-Joint (Rear) ②	UJ505
	U-Joint (Rear) ②	UJ430	1960-1959 Galaxie w/ Inner Lock Rings: [Type 1]		
	Brute Force Greaseable	UJ255		U-Joint (Front) ①	UJ507
	U-Bolt Kit (Rear)	UJ534-10		U-Joint (Rear) ②	UJ505
1965-1963 Galaxie w/ 200, 223 & 240 Eng.: [Type 1]			1960-1959 Country Sedan, Country Squire & Fairlane w/ Outer Lock Rings: [Type 1]		
	U-Joint (Front) ①	UJ429		U-Joint (Front) ①	UJ369
	Brute Force Greaseable	UJ250		Brute Force Greaseable	UJ280
	U-Joint (Rear) ②	UJ430		Brute Force Non Greaseable	UJ269
	Brute Force Greaseable	UJ255		(For Aluminum Drive Shaft)	UJ369C
	U-Bolt Kit (Rear)	UJ534-10		U-Joint (Rear) ②	UJ369
1965-1963 Galaxie w/ 221, 260, 289 & 352 Eng.: [Type 1]				Brute Force Greaseable	UJ280
	U-Joint (Front) ①	UJ429		Brute Force Non Greaseable	UJ269
	Brute Force Greaseable	UJ250		(For Aluminum Drive Shaft)	UJ369C
	U-Joint (Rear) ②	UJ430	1960-1959 Galaxie w/ Outer Lock Rings: [Type 1]		
	Brute Force Greaseable	UJ255		U-Joint (Front) ①	UJ369
	U-Bolt Kit (Rear)	UJ534-10		Brute Force Greaseable	UJ280
1965-1963 Galaxie w/ 390, 406 & 427 Eng.: [Type 1]				Brute Force Non Greaseable	UJ269
	U-Joint (Front) ①	UJ433		(For Aluminum Drive Shaft)	UJ369C
	Brute Force Greaseable	UJ260		U-Joint (Rear) ②	UJ369
	U-Joint (Rear) ②	UJ434		Brute Force Greaseable	UJ280
	Brute Force Greaseable	UJ265		Brute Force Non Greaseable	UJ269
	Brute Force Non Greaseable	UJ264		(For Aluminum Drive Shaft)	UJ369C
	U-Bolt Kit (Rear)	UJ534-10	1958-1949 w/ Inner Lock Rings: [Type 1]		
1963 Country Sedan, Country Squire & Fairlane w/ 390, 406 & 427 Eng. Thru 5/63: [Type 1]				U-Joint (Front) ①	UJ507
	U-Joint (Front) ①	UJ429		U-Joint (Rear)	UJ12134
	Brute Force Greaseable	UJ250	1958-1949 w/ Outer Lock Rings: [Type 1]		
	U-Joint (Rear) ②	UJ430		U-Joint (Front) ①	UJ369
	Brute Force Greaseable	UJ255		Brute Force Greaseable	UJ280
	U-Bolt Kit (Rear)	UJ534-10		Brute Force Non Greaseable	UJ269
1962-1961 Country Sedan & Country Squire: [Type 1]				(For Aluminum Drive Shaft)	UJ369C
	U-Joint (Front) ①	UJ429		U-Joint (Rear) ②	UJ369
	Brute Force Greaseable	UJ250		Brute Force Greaseable	UJ280
	U-Joint (Rear) ②	UJ430		Brute Force Non Greaseable	UJ269
	Brute Force Greaseable	UJ255		(For Aluminum Drive Shaft)	UJ369C
	U-Bolt Kit (Rear)	UJ534-10			
1962-1961 Galaxie: [Type 1]					
	U-Joint (Front) ①	UJ429			
	Brute Force Greaseable	UJ250			
	U-Joint (Rear) ②	UJ430			
	Brute Force Greaseable	UJ255			
	U-Bolt Kit (Rear)	UJ534-10			

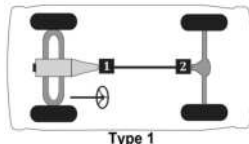

Passenger cars, light & medium trucks

Ford (RWD) Elite, Gran Torino, LTD II, Ranchero, Torino

MFG./YEAR	MODEL & LOCATION	PART NO.	MFG./YEAR	MODEL & LOCATION	PART NO.
Drive Shaft			Drive Shaft (Cont.)		
U-Joint			U-Joint (Cont.)		
1979	LTD II w/ Inner Lock Rings: [Type 1]		1976-1975 Elite, Gran Torino & Torino w/ 400 & 460 Eng.s.: [Type 1]		
	U-Joint (Front) ①	UJ534G	U-Joint (Front) ①		UJ354
	Brute Force Greaseable	UJ235	Brute Force Greaseable		UJ270
	Brute Force Non Greaseable	UJ234	Brute Force Non Greaseable		UJ254
	Clamp Kit (Front)	UJ530-10	(For Aluminum Drive Shaft)		UJ354C
	U-Joint (Rear) ②	UJ375	U-Joint (Rear) ②		UJ434
1979	LTD II w/ Outer Lock Rings: [Type 1]		Brute Force Greaseable		UJ265
	U-Joint (Front) ①	UJ354	Brute Force Non Greaseable		UJ264
	Brute Force Greaseable	UJ270	U-Bolt Kit (Rear)		UJ534-10
	Brute Force Non Greaseable	UJ254	1976-1975 Elite, Gran Torino & Torino w/ 351 Eng. & 3.875" Yoke: [Type 1]		
	(For Aluminum Drive Shaft)	UJ354C	U-Joint (Front) ①		UJ354
	U-Joint (Rear) ②	UJ434	Brute Force Greaseable		UJ270
	Brute Force Greaseable	UJ265	Brute Force Non Greaseable		UJ254
	Brute Force Non Greaseable	UJ264	(For Aluminum Drive Shaft)		UJ354C
	U-Bolt Kit (Rear)	UJ534-10	U-Joint (Rear) ②		UJ434
1979-1966 Ranchero w/ 3.5" Yoke: [Type 1]			Brute Force Greaseable		UJ265
	U-Joint (Front) ①	UJ369	Brute Force Non Greaseable		UJ264
	Brute Force Greaseable	UJ280	U-Bolt Kit (Rear)		UJ534-10
	Brute Force Non Greaseable	UJ269	1974-1968 Gran Torino & Torino w/ 3.5" Yoke: [Type 1]		
	(For Aluminum Drive Shaft)	UJ369C	U-Joint (Front) ①		UJ369
	U-Joint (Rear) ②	UJ430	Brute Force Greaseable		UJ280
	Brute Force Greaseable	UJ255	Brute Force Non Greaseable		UJ269
	U-Bolt Kit (Rear)	UJ534-10	(For Aluminum Drive Shaft)		UJ369C
1979-1966 Ranchero w/ 3.875" Yoke: [Type 1]			U-Joint (Rear) ②		UJ430
	U-Joint (Front) ①	UJ354	Brute Force Greaseable		UJ255
	Brute Force Greaseable	UJ270	U-Bolt Kit (Rear)		UJ534-10
	Brute Force Non Greaseable	UJ254	1974-1968 Gran Torino & Torino w/ 3.875" Yoke: [Type 1]		
	(For Aluminum Drive Shaft)	UJ354C	U-Joint (Front) ①		UJ354
	U-Joint (Rear) ②	UJ434	Brute Force Greaseable		UJ270
	Brute Force Greaseable	UJ265	Brute Force Non Greaseable		UJ254
	Brute Force Non Greaseable	UJ264	(For Aluminum Drive Shaft)		UJ354C
	U-Bolt Kit (Rear)	UJ534-10	U-Joint (Rear) ②		UJ434
1978-1977 LTD II: [Type 1]			Brute Force Greaseable		UJ265
	U-Joint (Front) ①	UJ354	Brute Force Non Greaseable		UJ264
	Brute Force Greaseable	UJ270	U-Bolt Kit (Rear)		UJ534-10
	Brute Force Non Greaseable	UJ254	1970-1966 Fairlane w/ 3.5" Yoke: [Type 1]		
	(For Aluminum Drive Shaft)	UJ354C	U-Joint (Front) ①		UJ369
	U-Joint (Rear) ②	UJ434	Brute Force Greaseable		UJ280
	Brute Force Greaseable	UJ265	Brute Force Non Greaseable		UJ269
	Brute Force Non Greaseable	UJ264	(For Aluminum Drive Shaft)		UJ369C
	U-Bolt Kit (Rear)	UJ534-10	U-Joint (Rear) ②		UJ430
1976-1975 Elite, Gran Torino & Torino w/ 351 Eng. & 3.5" Yoke: [Type 1]			Brute Force Greaseable		UJ255
	U-Joint (Front) ①	UJ369	U-Bolt Kit (Rear)		UJ534-10
	Brute Force Greaseable	UJ280			(Continued)
	Brute Force Non Greaseable	UJ269			
	(For Aluminum Drive Shaft)	UJ369C			
	U-Joint (Rear) ②	UJ430			
	Brute Force Greaseable	UJ255			
	U-Bolt Kit (Rear)	UJ534-10			

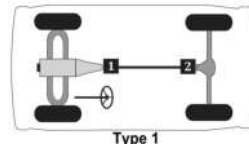

Passenger cars, light & medium trucks

Ford (RWD) Elite, Gran Torino, LTD II, Ranchero, Torino -- (Cont.)

MFG./YEAR	MODEL & LOCATION	PART NO.	MFG./YEAR	MODEL & LOCATION	PART NO.
Drive Shaft (Cont.)			Drive Shaft (Cont.)		
U-Joint (Cont.)			U-Joint (Cont.)		
1970-1966 Fairlane w/ 3.875" Yoke: [Type 1]			1962-1961 Ranchero: [Type 1]		
	U-Joint (Front)Ⓚ	UJ354		U-Joint (Front)Ⓚ	UJ429
	Brute Force Greaseable	UJ270		Brute Force Greaseable	UJ250
	Brute Force Non Greaseable	UJ254		U-Joint (Rear)Ⓛ	UJ430
	(For Aluminum Drive Shaft)	UJ354C		Brute Force Greaseable	UJ255
	U-Joint (Rear)Ⓛ	UJ434		U-Bolt Kit (Rear)	UJ534-10
	Brute Force Greaseable	UJ265	1960-1959 Ranchero w/ Inner Lock Rings: [Type 1]		
	Brute Force Non Greaseable	UJ264		U-Joint (Front)Ⓚ	UJ507
	U-Bolt Kit (Rear)	UJ534-10		U-Joint (Rear)Ⓛ	UJ505
1965-1963 Ranchero w/ 170 & 200 Eng.s.: [Type 1]			1960-1959 Ranchero w/ Outer Lock Rings: [Type 1]		
	U-Joint (Front)Ⓚ	UJ429		U-Joint (Front)Ⓚ	UJ369
	Brute Force Greaseable	UJ250		Brute Force Greaseable	UJ280
	U-Joint (Rear)Ⓛ	UJ430		Brute Force Non Greaseable	UJ269
	Brute Force Greaseable	UJ255		(For Aluminum Drive Shaft)	UJ369C
	U-Bolt Kit (Rear)	UJ534-10		U-Joint (Rear)Ⓛ	UJ369
1965-1963 Ranchero w/ 260, 289 & 352 Eng.s.: [Type 1]				Brute Force Greaseable	UJ280
	U-Joint (Front)Ⓚ	UJ429		Brute Force Non Greaseable	UJ269
	Brute Force Greaseable	UJ250		(For Aluminum Drive Shaft)	UJ369C
	U-Joint (Rear)Ⓛ	UJ430	1958-1957 Ranchero w/ Inner Lock Rings: [Type 1]		
	Brute Force Greaseable	UJ255		U-Joint (Front)Ⓚ	UJ507
	U-Bolt Kit (Rear)	UJ534-10		U-Joint (Rear)	UJ12134
1965-1963 Fairlane w/ 170 & 200 Eng.s.: [Type 1]			1958-1957 Ranchero w/ Outer Lock Rings: [Type 1]		
	U-Joint (Front)Ⓚ	UJ429		U-Joint (Front)Ⓚ	UJ369
	Brute Force Greaseable	UJ250		Brute Force Greaseable	UJ280
	U-Joint (Rear)Ⓛ	UJ430		Brute Force Non Greaseable	UJ269
	Brute Force Greaseable	UJ255		(For Aluminum Drive Shaft)	UJ369C
	U-Bolt Kit (Rear)	UJ534-10		U-Joint (Rear)Ⓛ	UJ369
1965-1963 Fairlane w/ 390 & 427 Eng.s. From 6/63: [Type 1]				Brute Force Greaseable	UJ280
	U-Joint (Front)Ⓚ	UJ433		Brute Force Non Greaseable	UJ269
	Brute Force Greaseable	UJ260		(For Aluminum Drive Shaft)	UJ369C
	U-Joint (Rear)Ⓛ	UJ434		U-Joint (Rear)Ⓛ	UJ369
	Brute Force Greaseable	UJ265		Brute Force Greaseable	UJ280
	Brute Force Non Greaseable	UJ264		Brute Force Non Greaseable	UJ269
	U-Bolt Kit (Rear)	UJ534-10		(For Aluminum Drive Shaft)	UJ369C
1963 Fairlane w/ 390 & 427 Eng.s. Thru 5/63: [Type 1]					
	U-Joint (Front)Ⓚ	UJ429			
	Brute Force Greaseable	UJ250			
	U-Joint (Rear)Ⓛ	UJ430			
	Brute Force Greaseable	UJ255			
	U-Bolt Kit (Rear)	UJ534-10			

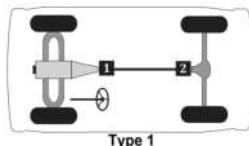

Passenger cars, light & medium trucks

Ford (RWD) Fairmont, Maverick

MFG./YEAR	MODEL & LOCATION	PART NO.	MFG./YEAR	MODEL & LOCATION	PART NO.
Drive Shaft			Drive Shaft (Cont.)		
U-Joint			U-Joint (Cont.)		
1983-1979 Fairmont: [Type 1]			1977-1970 Maverick: [Type 1]		
	U-Joint (Front)❶	UJ369		U-Joint (Front)❶	UJ369
	Brute Force Greaseable	UJ280		Brute Force Greaseable	UJ280
	Brute Force Non Greaseable	UJ269		Brute Force Non Greaseable	UJ269
	(For Aluminum Drive Shaft)	UJ369C		(For Aluminum Drive Shaft)	UJ369C
	U-Joint (Rear)❷	UJ369		U-Joint (Rear)❷	UJ430
	Brute Force Greaseable	UJ280		Brute Force Greaseable	UJ255
	Brute Force Non Greaseable	UJ269		U-Bolt Kit (Rear)	UJ534-10
	(For Aluminum Drive Shaft)	UJ369C			
1978 Fairmont: [Type 1]					
	U-Joint (Front)❶	UJ369			
	Brute Force Greaseable	UJ280			
	Brute Force Non Greaseable	UJ269			
	(For Aluminum Drive Shaft)	UJ369C			
	U-Joint (Rear)❷	UJ430			
	Brute Force Greaseable	UJ255			
	U-Bolt Kit (Rear)	UJ534-10			

Ford (RWD) Falcon

MFG./YEAR	MODEL & LOCATION	PART NO.	MFG./YEAR	MODEL & LOCATION	PART NO.
Drive Shaft			Drive Shaft (Cont.)		
U-Joint			U-Joint (Cont.)		
1970-1969 Falcon: [Type 1]			1964-1963 Falcon w/ 6 Cyl. Eng.: [Type 1]		
	U-Joint (Front)❶	UJ369		U-Joint (Front)❶	UJ514G
	Brute Force Greaseable	UJ280		U-Joint (Rear)❷	UJ514G
	Brute Force Non Greaseable	UJ269		1964-1963 Falcon w/ 8 Cyl. Eng. & Inner Lock	
	(For Aluminum Drive Shaft)	UJ369C		Rings: [Type 1]	
	U-Joint (Rear)❷	UJ430		U-Joint (Front)❶	UJ507
	Brute Force Greaseable	UJ255		U-Joint (Rear)❷	UJ498
	U-Bolt Kit (Rear)	UJ534-10		1964-1963 Falcon w/ 8 Cyl. Eng. & Outer Lock	
	1968-1965 Falcon w/ 170 & 200 Eng. & 3 Spd.			Rings: [Type 1]	
	Man. Trans.: [Type 1]			U-Joint (Front)❶	UJ369
	U-Joint (Front)❶	UJ514G		Brute Force Greaseable	UJ280
	U-Joint (Rear)❷	UJ514G		Brute Force Non Greaseable	UJ269
	1968-1965 Falcon w/ Inner Lock Rings Exc. 170 &			(For Aluminum Drive Shaft)	UJ369C
	200 Eng. & 3 Spd. Man. Trans.:			U-Joint (Rear)❷	UJ430
	[Type 1]			Brute Force Greaseable	UJ255
	U-Joint (Front)❶	UJ507		U-Bolt Kit (Rear)	UJ534-10
	U-Joint (Rear)❷	UJ498		1962-1960 Falcon: [Type 1]	
	U-Bolt Kit (Rear)	UJ534-10		U-Joint (Front)❶	UJ514G
	1968-1965 Falcon w/ Outer Lock Rings Exc. 170			U-Joint (Rear)❷	UJ514G
	& 200 Eng. & 3 Spd. Man. Trans.:				
	[Type 1]				
	U-Joint (Front)❶	UJ369			
	Brute Force Greaseable	UJ280			
	Brute Force Non Greaseable	UJ269			
	(For Aluminum Drive Shaft)	UJ369C			
	U-Joint (Rear)❷	UJ430			
	Brute Force Greaseable	UJ255			
	U-Bolt Kit (Rear)	UJ534-10			

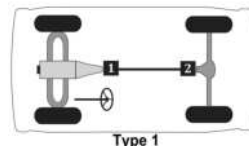

Passenger cars, light & medium trucks

Ford (RWD) Granada, LTD (from 1983)

MFG./YEAR	MODEL & LOCATION	PART NO.	MFG./YEAR	MODEL & LOCATION	PART NO.
Drive Shaft			Drive Shaft (Cont.)		
U-Joint			U-Joint (Cont.)		
1986-1983 LTD w/ 3.5" Yoke: [Type 1]			1977-1975 Granada w/ 3.5" Yoke: [Type 1]		
	U-Joint (Front)ⓐ	UJ369		U-Joint (Front)ⓐ	UJ369
	<i>Brute Force Greaseable</i>	UJ280		<i>Brute Force Greaseable</i>	UJ280
	<i>Brute Force Non Greaseable</i>	UJ269		<i>Brute Force Non Greaseable</i>	UJ269
	(For Aluminum Drive Shaft)	UJ369C		(For Aluminum Drive Shaft)	UJ369C
	U-Joint (Rear)ⓑ	UJ369		U-Joint (Rear)ⓑ	UJ430
	<i>Brute Force Greaseable</i>	UJ280		<i>Brute Force Greaseable</i>	UJ255
	<i>Brute Force Non Greaseable</i>	UJ269		U-Bolt Kit (Rear)	UJ534-10
	(For Aluminum Drive Shaft)	UJ369C		1977-1975 Granada w/ 3.875" Yoke: [Type 1]	
	1986-1983 LTD w/ 3.875" Yoke: [Type 1]			U-Joint (Front)ⓐ	UJ354
	U-Joint (Front)ⓐ	UJ354		<i>Brute Force Greaseable</i>	UJ270
	<i>Brute Force Greaseable</i>	UJ270		<i>Brute Force Non Greaseable</i>	UJ254
	<i>Brute Force Non Greaseable</i>	UJ254		(For Aluminum Drive Shaft)	UJ354C
	(For Aluminum Drive Shaft)	UJ354C		U-Joint (Rear)ⓑ	UJ434
	U-Joint (Rear)ⓑ	UJ354		<i>Brute Force Greaseable</i>	UJ265
	<i>Brute Force Greaseable</i>	UJ270		<i>Brute Force Non Greaseable</i>	UJ264
	<i>Brute Force Non Greaseable</i>	UJ254		U-Bolt Kit (Rear)	UJ534-10
	(For Aluminum Drive Shaft)	UJ354C			
	1982-1981 Granada: [Type 1]				
	U-Joint (Front)ⓐ	UJ369			
	<i>Brute Force Greaseable</i>	UJ280			
	<i>Brute Force Non Greaseable</i>	UJ269			
	(For Aluminum Drive Shaft)	UJ369C			
	U-Joint (Rear)ⓑ	UJ369			
	<i>Brute Force Greaseable</i>	UJ280			
	<i>Brute Force Non Greaseable</i>	UJ269			
	(For Aluminum Drive Shaft)	UJ369C			
	1980-1978 Granada: [Type 1]				
	U-Joint (Front)ⓐ	UJ369			
	<i>Brute Force Greaseable</i>	UJ280			
	<i>Brute Force Non Greaseable</i>	UJ269			
	(For Aluminum Drive Shaft)	UJ369C			
	U-Joint (Rear)ⓑ	UJ430			
	<i>Brute Force Greaseable</i>	UJ255			
	U-Bolt Kit (Rear)	UJ534-10			

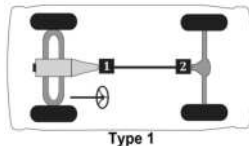

38 ▲ For Use w/ 1.063" Bearing Cap Application. ⓐ For Use w/ 1.188" Bearing Cap Application. ◇ For Use w/ Inner Lock Ring Application on Half Shaft. □ For Use w/ Outer Lock Ring Application on Half Shaft.

MFG./YEAR	MODEL & LOCATION	PART NO.	MFG./YEAR	MODEL & LOCATION	PART NO.
Drive Shaft			Drive Shaft (Cont.)		
U-Joint			U-Joint (Cont.)		
2021-2015 Mustang w/ Man. Trans. Exc. 8 Cyl. Eng.: [Type 1]			1995-1994 Mustang w/ 6 Cyl. Eng.: [Type 1]		
	U-Joint (Front)⓪	UJ331		U-Joint (Front)⓪	UJ369
	Brute Force Greaseable	UJ232		Brute Force Greaseable	UJ280
	Brute Force Non Greaseable	UJ231		Brute Force Non Greaseable	UJ269
	(For Aluminum Drive Shaft)	UJ331C		(For Aluminum Drive Shaft)	UJ369C
	U-Joint (Rear)⓪	UJ331		U-Joint (Rear)⓪	UJ369
	Brute Force Greaseable	UJ232		Brute Force Greaseable	UJ280
	Brute Force Non Greaseable	UJ231		Brute Force Non Greaseable	UJ269
	(For Aluminum Drive Shaft)	UJ331C		(For Aluminum Drive Shaft)	UJ369C
2020-2015 Mustang w/ 8 Cyl. Eng.: [Type 4]			1995-1994 Mustang w/ 8 Cyl. Eng.: [Type 1]		
	U-Joint (Front)⓪	UJ331		U-Joint (Front)⓪	UJ354
	Brute Force Greaseable	UJ232		Brute Force Greaseable	UJ270
	Brute Force Non Greaseable	UJ231		Brute Force Non Greaseable	UJ254
	(For Aluminum Drive Shaft)	UJ331C		(For Aluminum Drive Shaft)	UJ354C
	U-Joint (Rear)⓪	UJ331		U-Joint (Rear)⓪	UJ354
	Brute Force Greaseable	UJ232		Brute Force Greaseable	UJ270
	Brute Force Non Greaseable	UJ231		Brute Force Non Greaseable	UJ254
	(For Aluminum Drive Shaft)	UJ331C		(For Aluminum Drive Shaft)	UJ354C
2014-2013 Mustang Exc. GT500: [Type 1]			1993 Mustang w/ 4 Cyl. Eng.: [Type 1]		
	U-Joint (Front)⓪	UJ331		U-Joint (Front)⓪	UJ369
	Brute Force Greaseable	UJ232		Brute Force Greaseable	UJ280
	Brute Force Non Greaseable	UJ231		Brute Force Non Greaseable	UJ269
	(For Aluminum Drive Shaft)	UJ331C		(For Aluminum Drive Shaft)	UJ369C
	U-Joint (Rear)⓪	UJ331		U-Joint (Rear)⓪	UJ369
	Brute Force Greaseable	UJ232		Brute Force Greaseable	UJ280
	Brute Force Non Greaseable	UJ231		Brute Force Non Greaseable	UJ269
	(For Aluminum Drive Shaft)	UJ331C		(For Aluminum Drive Shaft)	UJ369C
2004-2001 Mustang Exc. Cobra: [Type 1]			1993-1987 Mustang w/ 8 Cyl. Eng. & Auto. Trans.: [Type 1]		
	U-Joint (Front)⓪	UJ354		U-Joint (Front)⓪	UJ369
	Brute Force Greaseable	UJ270		Brute Force Greaseable	UJ280
	Brute Force Non Greaseable	UJ254		Brute Force Non Greaseable	UJ269
	(For Aluminum Drive Shaft)	UJ354C		(For Aluminum Drive Shaft)	UJ369C
	U-Joint (Rear)⓪	UJ354		U-Joint (Rear)⓪	UJ369
	Brute Force Greaseable	UJ270		Brute Force Greaseable	UJ280
	Brute Force Non Greaseable	UJ254		Brute Force Non Greaseable	UJ269
	(For Aluminum Drive Shaft)	UJ354C		(For Aluminum Drive Shaft)	UJ369C
2004-2001 Mustang Cobra: [Type 1]			1993-1987 Mustang w/ 8 Cyl. Eng. & Man. Trans.: [Type 1]		
	U-Joint (Front)⓪	UJ331		U-Joint (Front)⓪	UJ354
	Brute Force Greaseable	UJ232		Brute Force Greaseable	UJ270
	Brute Force Non Greaseable	UJ231		Brute Force Non Greaseable	UJ254
	(For Aluminum Drive Shaft)	UJ331C		(For Aluminum Drive Shaft)	UJ354C
	U-Joint (Rear)⓪	UJ331		U-Joint (Rear)⓪	UJ354
	Brute Force Greaseable	UJ232		Brute Force Greaseable	UJ270
	Brute Force Non Greaseable	UJ231		Brute Force Non Greaseable	UJ254
	(For Aluminum Drive Shaft)	UJ331C		(For Aluminum Drive Shaft)	UJ354C
2000-1996 Mustang: [Type 1]					
	U-Joint (Front)⓪	UJ354			
	Brute Force Greaseable	UJ270			
	Brute Force Non Greaseable	UJ254			
	(For Aluminum Drive Shaft)	UJ354C			
	U-Joint (Rear)⓪	UJ354			
	Brute Force Greaseable	UJ270			
	Brute Force Non Greaseable	UJ254			
	(For Aluminum Drive Shaft)	UJ354C			

(Continued)

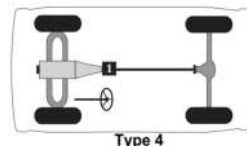
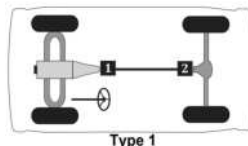

Passenger cars, light & medium trucks

Ford (RWD) Mustang -- (Cont.)

MFG./YEAR	MODEL & LOCATION	PART NO.	MFG./YEAR	MODEL & LOCATION	PART NO.
Drive Shaft (Cont.)			Drive Shaft (Cont.)		
U-Joint (Cont.)			U-Joint (Cont.)		
1992-1987 Mustang w/ 4 Cyl. Eng. & Auto.			1973-1970 Mustang w/ 3.5" Yoke: [Type 1]		
Trans.: [Type 1]					
	U-Joint (Front)Ⓚ	UJ369		U-Joint (Front)Ⓚ	UJ369
	<i>Brute Force Greaseable</i>	UJ280		<i>Brute Force Greaseable</i>	UJ280
	<i>Brute Force Non Greaseable</i>	UJ269		<i>Brute Force Non Greaseable</i>	UJ269
	(For Aluminum Drive Shaft)	UJ369C		(For Aluminum Drive Shaft)	UJ369C
	U-Joint (Rear)Ⓚ	UJ369		U-Joint (Rear)Ⓚ	UJ430
	<i>Brute Force Greaseable</i>	UJ280		<i>Brute Force Greaseable</i>	UJ255
	<i>Brute Force Non Greaseable</i>	UJ269		U-Bolt Kit (Rear)	UJ534-10
	(For Aluminum Drive Shaft)	UJ369C		1973-1970 Mustang w/ 3.875" Yoke: [Type 1]	
	1992-1987 Mustang w/ 4 Cyl. Eng., Man. Trans. & 3.5" Yoke: [Type 1]			U-Joint (Front)Ⓚ	UJ354
	U-Joint (Front)Ⓚ	UJ369		<i>Brute Force Greaseable</i>	UJ270
	<i>Brute Force Greaseable</i>	UJ280		<i>Brute Force Non Greaseable</i>	UJ254
	<i>Brute Force Non Greaseable</i>	UJ269		(For Aluminum Drive Shaft)	UJ354C
	(For Aluminum Drive Shaft)	UJ369C		U-Joint (Rear)Ⓚ	UJ434
	U-Joint (Rear)Ⓚ	UJ369		<i>Brute Force Greaseable</i>	UJ265
	<i>Brute Force Greaseable</i>	UJ280		<i>Brute Force Non Greaseable</i>	UJ264
	<i>Brute Force Non Greaseable</i>	UJ269		U-Bolt Kit (Rear)	UJ534-10
	(For Aluminum Drive Shaft)	UJ369C		1969-1968 Mustang w/ 200 Eng. Exc. 3 Spd. Man. Trans.: [Type 1]	
	1992-1987 Mustang w/ 4 Cyl. Eng., Man. Trans. & 3.875" Yoke: [Type 1]			U-Joint (Front)Ⓚ	UJ369
	U-Joint (Front)Ⓚ	UJ354		<i>Brute Force Greaseable</i>	UJ280
	<i>Brute Force Greaseable</i>	UJ270		<i>Brute Force Non Greaseable</i>	UJ269
	<i>Brute Force Non Greaseable</i>	UJ254		(For Aluminum Drive Shaft)	UJ369C
	(For Aluminum Drive Shaft)	UJ354C		U-Joint (Rear)Ⓚ	UJ430
	U-Joint (Rear)Ⓚ	UJ354		<i>Brute Force Greaseable</i>	UJ255
	<i>Brute Force Greaseable</i>	UJ270		U-Bolt Kit (Rear)	UJ534-10
	<i>Brute Force Non Greaseable</i>	UJ254		1969-1968 Mustang w/ 250, 289, 302 & 351 Eng.s.: [Type 1]	
	(For Aluminum Drive Shaft)	UJ354C		U-Joint (Front)Ⓚ	UJ369
	1986-1979 Mustang: [Type 1]			<i>Brute Force Greaseable</i>	UJ280
	U-Joint (Front)Ⓚ	UJ369		<i>Brute Force Non Greaseable</i>	UJ269
	<i>Brute Force Greaseable</i>	UJ280		(For Aluminum Drive Shaft)	UJ369C
	<i>Brute Force Non Greaseable</i>	UJ269		U-Joint (Rear)Ⓚ	UJ430
	(For Aluminum Drive Shaft)	UJ369C		<i>Brute Force Greaseable</i>	UJ255
	U-Joint (Rear)Ⓚ	UJ369		U-Bolt Kit (Rear)	UJ534-10
	<i>Brute Force Greaseable</i>	UJ280		1969-1968 Mustang w/ 390, 427 & 428 Eng.s.: [Type 1]	
	<i>Brute Force Non Greaseable</i>	UJ269		U-Joint (Front)Ⓚ	UJ354
	(For Aluminum Drive Shaft)	UJ369C		<i>Brute Force Greaseable</i>	UJ270
	1978-1974 Mustang II: [Type 1]			<i>Brute Force Non Greaseable</i>	UJ254
	U-Joint (Front)Ⓚ	UJ369		(For Aluminum Drive Shaft)	UJ354C
	<i>Brute Force Greaseable</i>	UJ280		U-Joint (Rear)Ⓚ	UJ434
	<i>Brute Force Non Greaseable</i>	UJ269		<i>Brute Force Greaseable</i>	UJ265
	(For Aluminum Drive Shaft)	UJ369C		<i>Brute Force Non Greaseable</i>	UJ264
	U-Joint (Rear)Ⓚ	UJ430		U-Bolt Kit (Rear)	UJ534-10
	<i>Brute Force Greaseable</i>	UJ255		1969-1967 Mustang w/ 200 Eng. & 3 Spd. Man. Trans.: [Type 1]	
	U-Bolt Kit (Rear)	UJ534-10		U-Joint (Front)Ⓚ	UJ514G
				U-Joint (Rear)Ⓚ	UJ514G

(Continued)

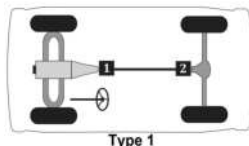

Passenger cars, light & medium trucks

(Cont.) -- Ford (RWD) Mustang

MFG./YEAR	MODEL & LOCATION	PART NO.	MFG./YEAR	MODEL & LOCATION	PART NO.
Drive Shaft (Cont.)			Drive Shaft (Cont.)		
U-Joint (Cont.)			U-Joint (Cont.)		
1967	Mustang w/ 200 Eng. & Auto. Trans.:		1966-1964	Mustang w/ 260 & 289 Engs. & Inner	
	[Type 1]			Lock Rings: [Type 1]	
	U-Joint (Front)Ⓢ	UJ369		U-Joint (Front)Ⓢ	UJ507
	Brute Force Greaseable	UJ280		U-Joint (Rear)Ⓢ	UJ498
	Brute Force Non Greaseable	UJ269		U-Bolt Kit (Rear)	UJ534-10
	(For Aluminum Drive Shaft)	UJ369C		1966-1964 Mustang w/ 200 Eng., Auto. Trans. &	
	U-Joint (Rear)Ⓢ	UJ430		Outer Lock Rings: [Type 1]	
	Brute Force Greaseable	UJ255		U-Joint (Front)Ⓢ	UJ369
	U-Bolt Kit (Rear)	UJ534-10		Brute Force Greaseable	UJ280
1967	Mustang w/ 289 Eng.: [Type 1]			Brute Force Non Greaseable	UJ269
	U-Joint (Front)Ⓢ	UJ369		(For Aluminum Drive Shaft)	UJ369C
	Brute Force Greaseable	UJ280		U-Joint (Rear)Ⓢ	UJ430
	Brute Force Non Greaseable	UJ269		Brute Force Greaseable	UJ255
	(For Aluminum Drive Shaft)	UJ369C		U-Bolt Kit (Rear)	UJ534-10
	U-Joint (Rear)Ⓢ	UJ430		1966-1964 Mustang w/ 260 & 289 Engs. & Outer	
	Brute Force Greaseable	UJ255		Lock Rings: [Type 1]	
	U-Bolt Kit (Rear)	UJ534-10		U-Joint (Front)Ⓢ	UJ369
1967	Mustang w/ 390 Eng.: [Type 1]			Brute Force Greaseable	UJ280
	U-Joint (Front)Ⓢ	UJ354		Brute Force Non Greaseable	UJ269
	Brute Force Greaseable	UJ270		(For Aluminum Drive Shaft)	UJ369C
	Brute Force Non Greaseable	UJ254		U-Joint (Rear)Ⓢ	UJ430
	(For Aluminum Drive Shaft)	UJ354C		Brute Force Greaseable	UJ255
	U-Joint (Rear)Ⓢ	UJ434		U-Bolt Kit (Rear)	UJ534-10
	Brute Force Greaseable	UJ265			
	Brute Force Non Greaseable	UJ264			
	U-Bolt Kit (Rear)	UJ534-10			
1966-1964	Mustang w/ 170 & 200 Engs. & Man.				
	Trans.: [Type 1]				
	U-Joint (Front)Ⓢ	UJ514G			
	U-Joint (Rear)Ⓢ	UJ514G			
1966-1964	Mustang w/ 200 Eng., Auto. Trans. &				
	Inner Lock Rings: [Type 1]				
	U-Joint (Front)Ⓢ	UJ507			
	U-Joint (Rear)Ⓢ	UJ498			
	U-Bolt Kit (Rear)	UJ534-10			

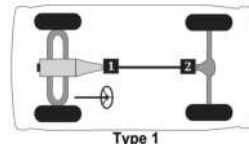

Passenger cars, light & medium trucks

Ford (RWD) Pinto

MFG./YEAR	MODEL & LOCATION	PART NO.	MFG./YEAR	MODEL & LOCATION	PART NO.
Drive Shaft			Drive Shaft (Cont.)		
U-Joint			U-Joint (Cont.)		
1980 Pinto: [Type 1]			1979-1971 Pinto: [Type 1]		
	U-Joint (Front) ①	UJ369		U-Joint (Front) ①	UJ369
	<i>Brute Force Greaseable</i>	UJ280		<i>Brute Force Greaseable</i>	UJ280
	<i>Brute Force Non Greaseable</i>	UJ269		<i>Brute Force Non Greaseable</i>	UJ269
	(For Aluminum Drive Shaft)	UJ369C		(For Aluminum Drive Shaft)	UJ369C
	U-Joint (Rear) ②	UJ369		U-Joint (Rear) ②	UJ430
	<i>Brute Force Greaseable</i>	UJ280		<i>Brute Force Greaseable</i>	UJ255
	<i>Brute Force Non Greaseable</i>	UJ269		<i>U-Bolt Kit (Rear)</i>	UJ534-10
	(For Aluminum Drive Shaft)	UJ369C			

Ford (RWD) Thunderbird

MFG./YEAR	MODEL & LOCATION	PART NO.	MFG./YEAR	MODEL & LOCATION	PART NO.
Drive Shaft			Drive Shaft (Cont.)		
U-Joint			U-Joint (Cont.)		
2005-2002 Thunderbird:			1982-1980 Thunderbird: [Type 1]		
	<i>Flex Coupler</i>	VKJF98020		U-Joint (Front) ①	UJ369
1997-1994 Thunderbird: [Type 1]				<i>Brute Force Greaseable</i>	UJ280
	U-Joint (Front) ①	UJ354		<i>Brute Force Non Greaseable</i>	UJ269
	<i>Brute Force Greaseable</i>	UJ270		(For Aluminum Drive Shaft)	UJ369C
	<i>Brute Force Non Greaseable</i>	UJ254		U-Joint (Rear) ②	UJ379
	(For Aluminum Drive Shaft)	UJ354C		<i>Brute Force Greaseable</i>	UJ280
	U-Joint (Rear) ②	UJ354		<i>Brute Force Non Greaseable</i>	UJ269
	<i>Brute Force Greaseable</i>	UJ270		Centering Ball Kit	UJ612
	<i>Brute Force Non Greaseable</i>	UJ254		Flange Yoke	UJ627
	(For Aluminum Drive Shaft)	UJ354C		H Yoke	UJ647
1993-1987 Thunderbird w/ 3.5" Yoke: [Type 1]			1979 Thunderbird w/ Inner Lock Rings:		
	U-Joint (Front) ①	UJ369	[Type 1]		
	<i>Brute Force Greaseable</i>	UJ280		U-Joint (Front) ①	UJ534G
	<i>Brute Force Non Greaseable</i>	UJ269		<i>Brute Force Greaseable</i>	UJ235
	(For Aluminum Drive Shaft)	UJ369C		<i>Brute Force Non Greaseable</i>	UJ234
	U-Joint (Rear) ②	UJ369		U-Joint (Rear) ②	UJ375
	<i>Brute Force Greaseable</i>	UJ280		<i>U-Bolt Kit (Rear)</i>	UJ534-10
	<i>Brute Force Non Greaseable</i>	UJ269	1979 Thunderbird w/ Outer Lock Rings:		
	(For Aluminum Drive Shaft)	UJ369C	[Type 1]		
1993-1987 Thunderbird w/ 3.875" Yoke: [Type 1]				U-Joint (Front) ①	UJ354
	U-Joint (Front) ①	UJ354		<i>Brute Force Greaseable</i>	UJ270
	<i>Brute Force Greaseable</i>	UJ270		<i>Brute Force Non Greaseable</i>	UJ254
	<i>Brute Force Non Greaseable</i>	UJ254		(For Aluminum Drive Shaft)	UJ354C
	(For Aluminum Drive Shaft)	UJ354C		U-Joint (Rear) ②	UJ434
	U-Joint (Rear) ②	UJ354		<i>Brute Force Greaseable</i>	UJ265
	<i>Brute Force Greaseable</i>	UJ270		<i>Brute Force Non Greaseable</i>	UJ264
	<i>Brute Force Non Greaseable</i>	UJ254		<i>U-Bolt Kit (Rear)</i>	UJ534-10
	(For Aluminum Drive Shaft)	UJ354C	1978-1977 Thunderbird: [Type 1]		
1986-1983 Thunderbird: [Type 1]				U-Joint (Front) ①	UJ354
	U-Joint (Front) ①	UJ369		<i>Brute Force Greaseable</i>	UJ270
	<i>Brute Force Greaseable</i>	UJ280		<i>Brute Force Non Greaseable</i>	UJ254
	<i>Brute Force Non Greaseable</i>	UJ269		(For Aluminum Drive Shaft)	UJ354C
	(For Aluminum Drive Shaft)	UJ369C		U-Joint (Rear) ②	UJ434
	U-Joint (Rear) ②	UJ369		<i>Brute Force Greaseable</i>	UJ265
	<i>Brute Force Greaseable</i>	UJ280		<i>Brute Force Non Greaseable</i>	UJ264
	<i>Brute Force Non Greaseable</i>	UJ269		<i>U-Bolt Kit (Rear)</i>	UJ534-10
	(For Aluminum Drive Shaft)	UJ369C			

(Continued)

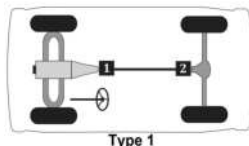

Passenger cars, light & medium trucks

(Cont.) -- Ford (RWD) Thunderbird

MFG./YEAR	MODEL & LOCATION	PART NO.	MFG./YEAR	MODEL & LOCATION	PART NO.
Drive Shaft (Cont.)			Drive Shaft (Cont.)		
U-Joint (Cont.)			U-Joint (Cont.)		
1976-1973 Thunderbird: [Type 1]			1966-1963 Thunderbird: [Type 1]		
	U-Joint (Front)ⓐ	UJ354		U-Joint (Front)ⓐ	UJ354
	<i>Brute Force Greaseable</i>	UJ270		<i>Brute Force Greaseable</i>	UJ270
	<i>Brute Force Non Greaseable</i>	UJ254		<i>Brute Force Non Greaseable</i>	UJ254
	(For Aluminum Drive Shaft)	UJ354C		(For Aluminum Drive Shaft)	UJ354C
	U-Joint (Rear)ⓑ	UJ354		U-Joint (Rear)ⓑ	UJ354
	<i>Brute Force Greaseable</i>	UJ270		<i>Brute Force Greaseable</i>	UJ270
	<i>Brute Force Non Greaseable</i>	UJ254		<i>Brute Force Non Greaseable</i>	UJ254
	(For Aluminum Drive Shaft)	UJ354C		(For Aluminum Drive Shaft)	UJ354C
	1972 Thunderbird: [Type 1]			1962 Thunderbird w/ Outer Lock Rings:	
	U-Joint (Front)ⓐ	UJ354		[Type 1]	
	<i>Brute Force Greaseable</i>	UJ270		U-Joint (Front)ⓐ	UJ369
	<i>Brute Force Non Greaseable</i>	UJ254		<i>Brute Force Greaseable</i>	UJ280
	(For Aluminum Drive Shaft)	UJ354C		<i>Brute Force Non Greaseable</i>	UJ269
	U-Joint (Rear)ⓑ	UJ434		(For Aluminum Drive Shaft)	UJ369C
	<i>Brute Force Greaseable</i>	UJ265		U-Joint (Rear)ⓑ	UJ353
	<i>Brute Force Non Greaseable</i>	UJ264		<i>Brute Force Greaseable</i>	UJ275
	U-Bolt Kit (Rear)	UJ534-10		1962 Thunderbird w/ Inner Lock Rings:	
	1971-1968 Thunderbird: [Type 1]			[Type 1]	
	U-Joint (Front)ⓐ	[2] UJ534G		U-Joint (Front)ⓐ	UJ429
	<i>Brute Force Greaseable</i>	UJ235		<i>Brute Force Greaseable</i>	UJ250
	<i>Brute Force Non Greaseable</i>	UJ234		U-Joint (Rear)ⓑ	UJ431
	U-Joint (Rear)ⓑ	[2] UJ534G		1961-1956 Thunderbird: [Type 1]	
	<i>Brute Force Greaseable</i>	UJ235		U-Joint (Front)ⓐ	UJ369
	<i>Brute Force Non Greaseable</i>	UJ234		<i>Brute Force Greaseable</i>	UJ280
	1967 Thunderbird 2 Door Model: [Type 1]			<i>Brute Force Non Greaseable</i>	UJ269
	U-Joint (Front)ⓐ	UJ354		(For Aluminum Drive Shaft)	UJ369C
	<i>Brute Force Greaseable</i>	UJ270		U-Joint (Rear)ⓑ	UJ507
	<i>Brute Force Non Greaseable</i>	UJ254		1955 Thunderbird: [Type 1]	
	(For Aluminum Drive Shaft)	UJ354C		U-Joint (Front)ⓐ	UJ507
	U-Joint (Rear)ⓑ	UJ434		U-Joint (Rear)ⓑ	UJ12134
	<i>Brute Force Greaseable</i>	UJ265			
	<i>Brute Force Non Greaseable</i>	UJ264			
	U-Bolt Kit (Rear)	UJ534-10			
	1967 Thunderbird 4 Door Model: [Type 5]				
	U-Joint (Frt. Shaft; Frt.)ⓐ	UJ354			
	<i>Brute Force Greaseable</i>	UJ270			
	<i>Brute Force Non Greaseable</i>	UJ254			
	(For Aluminum Drive Shaft)	UJ354C			
	U-Joint (Frt. Shaft; Rr.)ⓑ	UJ354			
	<i>Brute Force Greaseable</i>	UJ270			
	<i>Brute Force Non Greaseable</i>	UJ254			
	(For Aluminum Drive Shaft)	UJ354C			
	U-Joint (Rr. Shaft; Frt.)ⓑ	UJ354			
	<i>Brute Force Greaseable</i>	UJ270			
	<i>Brute Force Non Greaseable</i>	UJ254			
	(For Aluminum Drive Shaft)	UJ354C			
	U-Joint (Rr. Shaft; Rr.)ⓑ	UJ354			
	<i>Brute Force Greaseable</i>	UJ270			
	<i>Brute Force Non Greaseable</i>	UJ254			
	(For Aluminum Drive Shaft)	UJ354C			

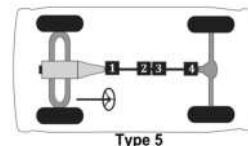
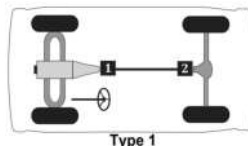

Passenger cars, light & medium trucks

Hyundai

MFG./YEAR	MODEL & LOCATION	PART NO.	MFG./YEAR	MODEL & LOCATION	PART NO.
Drive Shaft					
U-Joint					
2013-2009 Genesis:					
	Flex Coupler	VKJF98025			

Hyundai CUV

Drive Shaft					
U-Joint					
2009-2004 Tucson w/ AWD:					
	Flex Coupler	VKJF98023			
2006-2000 Santa Fe:					
	Flex Coupler	VKJF98023			

Jaguar

MFG./YEAR	MODEL & LOCATION	PART NO.	MFG./YEAR	MODEL & LOCATION	PART NO.
Drive Shaft			Drive Shaft (Cont.)		
U-Joint			U-Joint (Cont.)		
1985-1961 2 Joint Shaft: [Type 8]			1985-1961 3 Joint Shaft: [Type 9]		
	U-Joint (Front)⊙	UJ369		U-Joint (Front)⊙	UJ369
	<i>Brute Force Greaseable</i>	UJ280		<i>Brute Force Greaseable</i>	UJ280
	<i>Brute Force Non Greaseable</i>	UJ269		<i>Brute Force Non Greaseable</i>	UJ269
	(For Aluminum Drive Shaft)	UJ369C		(For Aluminum Drive Shaft)	UJ369C
	U-Joint (Rear)⊙	UJ369		U-Joint (Center)⊙	UJ369
	<i>Brute Force Greaseable</i>	UJ280		<i>Brute Force Greaseable</i>	UJ280
	<i>Brute Force Non Greaseable</i>	UJ269		<i>Brute Force Non Greaseable</i>	UJ269
	(For Aluminum Drive Shaft)	UJ369C		(For Aluminum Drive Shaft)	UJ369C
	U-Joint (Rear Half Shaft)⊙	[2] UJ330		U-Joint (Rear)⊙	UJ369
	<i>Brute Force Greaseable</i>	UJ295		<i>Brute Force Greaseable</i>	UJ280
	(For Aluminum Drive Shaft)	UJ330C		<i>Brute Force Non Greaseable</i>	UJ269
				(For Aluminum Drive Shaft)	UJ369C
				U-Joint (Rear Half Shaft)⊙	[2] UJ330
				<i>Brute Force Greaseable</i>	UJ295
				(For Aluminum Drive Shaft)	UJ330C
				1961-1955 All: [Type 8]	
	U-Joint (Front)⊙	UJ344		U-Joint (Front)⊙	UJ344
	U-Joint (Rear)⊙	UJ344		U-Joint (Rear)⊙	UJ344
	U-Joint (Rear Half Shaft)⊙	[2] UJ330		U-Joint (Rear Half Shaft)⊙	[2] UJ330
	<i>Brute Force Greaseable</i>	UJ295		<i>Brute Force Greaseable</i>	UJ295
	(For Aluminum Drive Shaft)	UJ330C		(For Aluminum Drive Shaft)	UJ330C

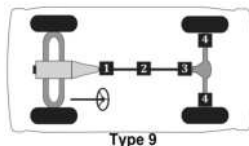
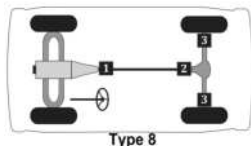

Passenger cars, light & medium trucks

Lincoln (RWD) Capri, Continental (thru 1987), Cosmopolitan, Mark II,III,IV,V,VI,VII,VIII, Mark VIII, Premiere, Town Car

MFG./YEAR	MODEL & LOCATION	PART NO.	MFG./YEAR	MODEL & LOCATION	PART NO.
Drive Shaft			Drive Shaft (Cont.)		
U-Joint			U-Joint (Cont.)		
2011-2006 Town Car: [Type 1]			1994-1981 Town Car w/ 3.875" Yoke: [Type 1]		
	U-Joint (Front)Ⓢ	UJ331		U-Joint (Front)Ⓢ	UJ354
	Brute Force Greaseable	UJ232		Brute Force Greaseable	UJ270
	Brute Force Non Greaseable	UJ231		Brute Force Non Greaseable	UJ254
	(For Aluminum Drive Shaft)	UJ331C		(For Aluminum Drive Shaft)	UJ354C
	U-Joint (Rear)Ⓢ	UJ331		U-Joint (Rear)Ⓢ	UJ354
	Brute Force Greaseable	UJ232		Brute Force Greaseable	UJ270
	Brute Force Non Greaseable	UJ231		Brute Force Non Greaseable	UJ254
	(For Aluminum Drive Shaft)	UJ331C		(For Aluminum Drive Shaft)	UJ354C
2005 Town Car From 3/18/05: [Type 1]			1992-1988 Mark VII From 11/87: [Type 1]		
	U-Joint (Front)Ⓢ	UJ331		U-Joint (Front)Ⓢ	UJ369
	Brute Force Greaseable	UJ232		Brute Force Greaseable	UJ280
	Brute Force Non Greaseable	UJ231		Brute Force Non Greaseable	UJ269
	(For Aluminum Drive Shaft)	UJ331C		(For Aluminum Drive Shaft)	UJ369C
	U-Joint (Rear)Ⓢ	UJ331		U-Joint (Rear)Ⓢ	[2] UJ379
	Brute Force Greaseable	UJ232		Brute Force Greaseable	UJ280
	Brute Force Non Greaseable	UJ231		Brute Force Non Greaseable	UJ269
	(For Aluminum Drive Shaft)	UJ331C		Centering Ball Kit	UJ617
2005 Town Car Thru 3/17/05: [Type 1]				H Yoke	UJ647
	U-Joint (Front)Ⓢ	UJ345		1988-1984 Mark VII To 10/31/87: [Type 1]	
	U-Joint (Rear)Ⓢ	UJ345		U-Joint (Front)Ⓢ	UJ369
2004-2003 Town Car: [Type 1]				Brute Force Greaseable	UJ280
	U-Joint (Front)Ⓢ	UJ345		Brute Force Non Greaseable	UJ269
	U-Joint (Rear)Ⓢ	UJ345		(For Aluminum Drive Shaft)	UJ369C
2002-1995 Town Car: [Type 1]				U-Joint (Rear)Ⓢ	[2] UJ379
	U-Joint (Front)Ⓢ	UJ354		Brute Force Greaseable	UJ280
	Brute Force Greaseable	UJ270		Brute Force Non Greaseable	UJ269
	Brute Force Non Greaseable	UJ254		Centering Ball Kit	UJ612
	(For Aluminum Drive Shaft)	UJ354C		Flange Yoke	UJ627
	U-Joint (Rear)Ⓢ	UJ354		H Yoke	UJ647
	Brute Force Greaseable	UJ270		1987-1982 Continental: [Type 1]	
	Brute Force Non Greaseable	UJ254		U-Joint (Front)Ⓢ	UJ369
	(For Aluminum Drive Shaft)	UJ354C		Brute Force Greaseable	UJ280
1998-1993 Mark VIII: [Type 1]				Brute Force Non Greaseable	UJ269
	U-Joint (Front)Ⓢ	UJ354		(For Aluminum Drive Shaft)	UJ369C
	Brute Force Greaseable	UJ270		U-Joint (Rear)Ⓢ	[2] UJ379
	Brute Force Non Greaseable	UJ254		Brute Force Greaseable	UJ280
	(For Aluminum Drive Shaft)	UJ354C		Brute Force Non Greaseable	UJ269
	U-Joint (Rear)Ⓢ	UJ354		Centering Ball Kit	UJ612
	Brute Force Greaseable	UJ270		Flange Yoke	UJ627
	Brute Force Non Greaseable	UJ254		H Yoke	UJ647
	(For Aluminum Drive Shaft)	UJ354C		1983-1980 Mark VI w/ 3.5" Yoke: [Type 1]	
1994-1981 Town Car w/ 3.5" Yoke: [Type 1]				U-Joint (Front)Ⓢ	UJ369
	U-Joint (Front)Ⓢ	UJ369		Brute Force Greaseable	UJ280
	Brute Force Greaseable	UJ280		Brute Force Non Greaseable	UJ269
	Brute Force Non Greaseable	UJ269		(For Aluminum Drive Shaft)	UJ369C
	(For Aluminum Drive Shaft)	UJ369C		U-Joint (Rear)Ⓢ	UJ369
	U-Joint (Rear)Ⓢ	UJ369		Brute Force Greaseable	UJ280
	Brute Force Greaseable	UJ280		Brute Force Non Greaseable	UJ269
	Brute Force Non Greaseable	UJ269		(For Aluminum Drive Shaft)	UJ369C
	(For Aluminum Drive Shaft)	UJ369C			(Continued)

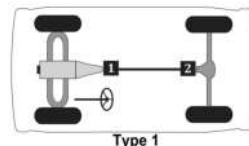

Passenger cars, light & medium trucks

Lincoln (RWD) Capri, Continental (thru 1987), Cosmopolitan, Mark II,III,IV,V,VI,VII,VIII, Mark VIII, Premiere, Town Car -- (Cont.)

MFG./YEAR	MODEL & LOCATION	PART NO.	MFG./YEAR	MODEL & LOCATION	PART NO.
Drive Shaft (Cont.)			Drive Shaft (Cont.)		
U-Joint (Cont.)			U-Joint (Cont.)		
1983-1980 Mark VI w/ 3.875" Yoke: [Type 1]			1978-1977 Mark V From 7/15/77: [Type 1]		
	U-Joint (Front)ⓐ	UJ354		U-Joint (Front)ⓐ	UJ354
	Brute Force Greaseable	UJ270		Brute Force Greaseable	UJ270
	Brute Force Non Greaseable	UJ254		Brute Force Non Greaseable	UJ254
	(For Aluminum Drive Shaft)	UJ354C		(For Aluminum Drive Shaft)	UJ354C
	U-Joint (Rear)ⓑ	UJ354		U-Joint (Rear)ⓑ	UJ434
	Brute Force Greaseable	UJ270		Brute Force Greaseable	UJ265
	Brute Force Non Greaseable	UJ254		Brute Force Non Greaseable	UJ264
	(For Aluminum Drive Shaft)	UJ354C		U-Bolt Kit (Rear)	UJ534-10
	1980 Continental w/ 3.5" Yoke: [Type 1]			1977 Mark V Thru 7/14/77: [Type 1]	
	U-Joint (Front)ⓐ	UJ369		U-Joint (Front)ⓐ	UJ354
	Brute Force Greaseable	UJ280		Brute Force Greaseable	UJ270
	Brute Force Non Greaseable	UJ269		Brute Force Non Greaseable	UJ254
	(For Aluminum Drive Shaft)	UJ369C		(For Aluminum Drive Shaft)	UJ354C
	U-Joint (Rear)ⓑ	UJ369		U-Joint (Rear)ⓑ	UJ354
	Brute Force Greaseable	UJ280		Brute Force Greaseable	UJ270
	Brute Force Non Greaseable	UJ269		Brute Force Non Greaseable	UJ254
	(For Aluminum Drive Shaft)	UJ369C		(For Aluminum Drive Shaft)	UJ354C
	1980 Continental w/ 3.875" Yoke: [Type 1]			1977-1966 Continental: [Type 1]	
	U-Joint (Front)ⓐ	UJ354		U-Joint (Front)ⓐ	UJ354 [2]
	Brute Force Greaseable	UJ270		Brute Force Greaseable	UJ270
	Brute Force Non Greaseable	UJ254		Brute Force Non Greaseable	UJ254
	(For Aluminum Drive Shaft)	UJ354C		(For Aluminum Drive Shaft)	UJ354C
	U-Joint (Rear)ⓑ	UJ354		U-Joint (Rear)ⓑ	UJ354
	Brute Force Greaseable	UJ270		Brute Force Greaseable	UJ270
	Brute Force Non Greaseable	UJ254		Brute Force Non Greaseable	UJ254
	(For Aluminum Drive Shaft)	UJ354C		(For Aluminum Drive Shaft)	UJ354C
	1979 Mark V: [Type 1]			H Yoke	UJ648
	U-Joint (Front)ⓐ	UJ354		1976-1973 Mark IV: [Type 1]	
	Brute Force Greaseable	UJ270		U-Joint (Front)ⓐ	UJ354
	Brute Force Non Greaseable	UJ254		Brute Force Greaseable	UJ270
	(For Aluminum Drive Shaft)	UJ354C		Brute Force Non Greaseable	UJ254
	U-Joint (Rear)ⓑ	UJ354		(For Aluminum Drive Shaft)	UJ354C
	Brute Force Greaseable	UJ270		U-Joint (Rear)ⓑ	UJ354
	Brute Force Non Greaseable	UJ254		Brute Force Greaseable	UJ270
	(For Aluminum Drive Shaft)	UJ354C		Brute Force Non Greaseable	UJ254
	1979-1978 Continental: [Type 1]			(For Aluminum Drive Shaft)	UJ354C
	U-Joint (Front)ⓐ	[2] UJ534G		1972 Mark IV: [Type 1]	
	Brute Force Greaseable	UJ235		U-Joint (Front)ⓐ	UJ354
	Brute Force Non Greaseable	UJ234		Brute Force Greaseable	UJ270
	U-Joint (Rear)ⓑ	[2] UJ534G		Brute Force Non Greaseable	UJ254
	Brute Force Greaseable	UJ235		(For Aluminum Drive Shaft)	UJ354C
	Brute Force Non Greaseable	UJ234		U-Joint (Rear)ⓑ	UJ434
	Ball Seat Repair Kit	UJ606		Brute Force Greaseable	UJ265
	Flange Yoke	UJ626		Brute Force Non Greaseable	UJ264
	H Yoke	UJ646		U-Bolt Kit (Rear)	UJ534-10

(Continued)

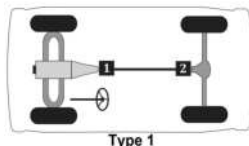

Passenger cars, light & medium trucks

(Cont.) -- Lincoln (RWD) Capri, Continental (thru 1987), Cosmopolitan, Mark II,III,IV,V,VI,VII,VIII, Mark VIII, Premiere, Town Car

MFG./YEAR	MODEL & LOCATION	PART NO.	MFG./YEAR	MODEL & LOCATION	PART NO.
Drive Shaft (Cont.)			Drive Shaft (Cont.)		
U-Joint (Cont.)			U-Joint (Cont.)		
1971-1968 Mark III: [Type 1]			1960-1950 Capri, Cosmopolitan & Premier:		
	U-Joint (Front)⓪	[2] UJ534G		[Type 1]	
	<i>Brute Force Greaseable</i>	UJ235		U-Joint (Front)⓪	UJ369
	<i>Brute Force Non Greaseable</i>	UJ234		<i>Brute Force Greaseable</i>	UJ280
	U-Joint (Rear)⓪	UJ534G		<i>Brute Force Non Greaseable</i>	UJ269
	<i>Brute Force Greaseable</i>	UJ235		(For Aluminum Drive Shaft)	UJ369C
	<i>Brute Force Non Greaseable</i>	UJ234		U-Joint (Rear)⓪	UJ369
1965-1963 Continental: [Type 1]				<i>Brute Force Greaseable</i>	UJ280
	U-Joint (Front)⓪	[2] UJ354		<i>Brute Force Non Greaseable</i>	UJ269
	<i>Brute Force Greaseable</i>	UJ270		(For Aluminum Drive Shaft)	UJ369C
	<i>Brute Force Non Greaseable</i>	UJ254	1957-1956 Mark II: [Type 1]		
	(For Aluminum Drive Shaft)	UJ354C		U-Joint (Front)⓪	UJ369
	U-Joint (Rear)⓪	UJ354		<i>Brute Force Greaseable</i>	UJ280
	<i>Brute Force Greaseable</i>	UJ270		<i>Brute Force Non Greaseable</i>	UJ269
	<i>Brute Force Non Greaseable</i>	UJ254		(For Aluminum Drive Shaft)	UJ369C
	(For Aluminum Drive Shaft)	UJ354C		U-Joint (Rear)⓪	UJ369
	H Yoke	UJ648		<i>Brute Force Greaseable</i>	UJ280
1962-1961 Continental: [Type 1]				<i>Brute Force Non Greaseable</i>	UJ269
	U-Joint (Front)⓪	UJ369		(For Aluminum Drive Shaft)	UJ369C
	<i>Brute Force Greaseable</i>	UJ280	2006-2000 LS:		
	<i>Brute Force Non Greaseable</i>	UJ269		Flex Coupler	VKJF98020
	(For Aluminum Drive Shaft)	UJ369C			
	U-Joint (Rear)⓪	UJ353			
	<i>Brute Force Greaseable</i>	UJ275			

Lincoln (RWD) LS

Drive Shaft
U-Joint
2006-2000 LS:
Flex CouplerVKJF98020

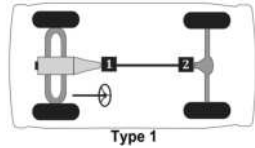

Passenger cars, light & medium trucks

Lincoln (RWD) Versailles

MFG./YEAR	MODEL & LOCATION	PART NO.	MFG./YEAR	MODEL & LOCATION	PART NO.
Drive Shaft			Drive Shaft (Cont.)		
U-Joint			U-Joint (Cont.)		
1980-1978 Versailles From 8/7/78: [Type 1]			1978-1977 Versailles Thru 8/6/78: [Type 1]		
	U-Joint (Front)Ⓛ	UJ369		U-Joint (Front)Ⓛ	UJ354
	Brute Force Greaseable	UJ280		Brute Force Greaseable	UJ270
	Brute Force Non Greaseable	UJ269		Brute Force Non Greaseable	UJ254
	(For Aluminum Drive Shaft)	UJ369C		(For Aluminum Drive Shaft)	UJ354C
	U-Joint (Rear)Ⓞ [2]	UJ379		U-Joint (Rear)Ⓞ	UJ354
	Brute Force Greaseable	UJ280		Brute Force Greaseable	UJ270
	Brute Force Non Greaseable	UJ269		Brute Force Non Greaseable	UJ254
	Centering Ball Kit	UJ612		(For Aluminum Drive Shaft)	UJ354C
	Flange Yoke	UJ627		H Yoke	UJ648
	H Yoke	UJ647			

Lotus

Drive Shaft	
U-Joint	
1975-1966 Europa: [Type 11]	
U-Joint (Rear Half Shaft)Ⓛ	[2] UJ344
1973-1957 Elan & Elite: [Type 1]	
U-Joint (Front)Ⓛ	UJ341
U-Joint (Rear)Ⓞ	UJ341

Mazda (RWD)

Drive Shaft		Drive Shaft (Cont.)	
U-Joint		U-Joint (Cont.)	
1995-1992 929: [Type 1]		1978-1976 Cosmo: [Type 2]	
U-Joint (Front)Ⓛ	UJ10431	U-Joint (Front)Ⓛ	UJ386
U-Joint (Rear)Ⓞ	UJ10431	U-Joint (Center)Ⓞ	UJ386
1991-1987 RX-7 w/ Turbocharged Eng.: [Type 1]		U-Joint (Rear)Ⓞ	UJ386
U-Joint (Front)Ⓛ	UJ10431	1978-1974 RX4: [Type 2]	
U-Joint (Rear)Ⓞ	UJ10431	U-Joint (Front)Ⓛ	UJ386
1983-1979 RX7: [Type 1]		U-Joint (Center)Ⓞ	UJ386
U-Joint (Front)Ⓛ	UJ397	U-Joint (Rear)Ⓞ	UJ386
U-Joint (Rear)Ⓞ	UJ397	1978-1971 R100, RX2 & RX3: [Type 1]	
1982-1979 626: [Type 2]		U-Joint (Front)Ⓛ	UJ397
U-Joint (Front)Ⓛ	UJ397	U-Joint (Rear)Ⓞ	UJ397
U-Joint (Center)Ⓞ	UJ397	1977-1971 616, 618, 808, 1200 & Mizer: [Type 1]	
U-Joint (Rear)Ⓞ	UJ397	U-Joint (Front)Ⓛ	UJ397
1981 GLC Wgn.: [Type 1]		U-Joint (Rear)Ⓞ	UJ397
U-Joint (Front)Ⓛ	UJ385		
U-Joint (Rear)Ⓞ	UJ385		
1980-1977 GLC: [Type 1]			
U-Joint (Front)Ⓛ	UJ385		
U-Joint (Rear)Ⓞ	UJ385		

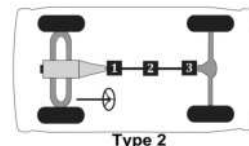
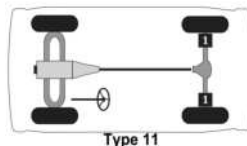
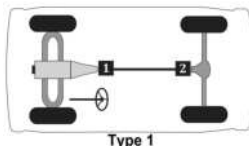

Passenger cars, light & medium trucks

Mazda MPV

MFG./YEAR	MODEL & LOCATION	PART NO.	MFG./YEAR	MODEL & LOCATION	PART NO.
Drive Shaft (4 W/D)					
U-Joint					
1995-1989 All: [Type 13]					
	U-Joint (Frnt. Shaft; Frt.)ⓐ	UJ386			
	U-Joint (Frnt. Shaft; Rr.)ⓐ	UJ386			
	U-Joint (Rr. Shaft; Frt.)ⓐ	UJ384			
	U-Joint (Rr. Shaft; Rr.)ⓐ	UJ384			

Mercedes-Benz

Drive Shaft			Drive Shaft (Cont.)		
U-Joint			U-Joint (Cont.)		
2020 E350:			2015 C400:		
Flex CouplerVKJF98028		Flex CouplerVKJF98030	
2020-2019 C300:			2015-2007 C250 & C350:		
Flex CouplerVKJF98028		Flex CouplerVKJF98006	
2020-2019 E450:			2011-2009 E250, E350 & E500:		
Flex CouplerVKJF98036		Flex CouplerVKJF98006	
2020-2019 E53 AMG:			2010-2007 SLK350:		
Flex CouplerVKJF98036		Flex CouplerVKJF98031	
2020-2019 CLS53 AMG:			2009-2007 E320:		
Flex CouplerVKJF98036		Flex CouplerVKJF98031	
2020-2018 E63 AMG S:			2008-2006 E350:		
Flex CouplerVKJF98036		Flex CouplerVKJF98031	
2020-2017 E300:			2006 CLS500:		
Flex CouplerVKJF98028		Flex CouplerVKJF98031	
2020-2017 C43 AMG:			2006-2000 C240 & C320:		
Flex CouplerVKJF98033		Flex CouplerVKJF98006	
2020-2017 C63 AMG:			2003-1998 E320:		
Flex CouplerVKJF98036		Flex CouplerVKJF98027	
2020-2017 SL550:			1998-1997 C230:		
Flex CouplerVKJF98036		Flex CouplerVKJF98027	
2019-2018 S560:			1997-1995 E300:		
Flex CouplerVKJF98033		Flex CouplerVKJF98027	
2019-2017 SLC300:			1996-1994 C220:		
Flex CouplerVKJF98033		Flex CouplerVKJF98027	
2019-2017 SLC43 AMG:			1993 400SEL:		
Flex CouplerVKJF98033		Flex CouplerVKJF98034	
2018 Maybach S560:			1993-1992 300SD:		
Flex CouplerVKJF98033		Flex CouplerVKJF98034	
2018 S63 AMG:			1993-1992 400E:		
Flex CouplerVKJF98033		Flex CouplerVKJF98034	
2018-2016 C350e:			1993-1990 300D:		
Flex CouplerVKJF98035		Flex CouplerVKJF98027	
2018-2015 C300:			1993-1988 300TE:		
Flex CouplerVKJF98030		Flex CouplerVKJF98027	
2018-2014 CLA250:			1993-1986 190E:		
Flex CouplerVKJF98026		Flex CouplerVKJF98027	
2018-2014 CLA45 AMG:			1993-1986 300E:		
Flex CouplerVKJF98026		Flex CouplerVKJF98027	
2017-2015 S550e:			1992 400SE:		
Flex CouplerVKJF98035		Flex CouplerVKJF98034	
2017-2005 CLS250, CLS350 & CLS500:			1991-1988 300SE & 300SEL:		
Flex CouplerVKJF98006		Flex CouplerVKJF98027	
2016 C450 AMG:				(Continued)	
Flex CouplerVKJF98032				

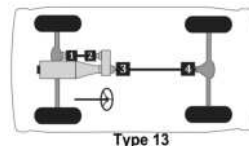

Passenger cars, light & medium trucks

Mercedes-Benz -- (Cont.)

MFG./YEAR	MODEL & LOCATION	PART NO.	MFG./YEAR	MODEL & LOCATION	PART NO.
Drive Shaft (Cont.)					
U-Joint (Cont.)					
1989-1988 300CE:					
	Flex Coupler	VKJF98027			
1989-1987 260E:					
	Flex Coupler	VKJF98027			
1987 190D:					
	Flex Coupler	VKJF98027			

Mercedes-Benz CUV GL Class, GLA Class

<p>Drive Shaft</p> <p>U-Joint</p> <p>2021-2020 GLE350:</p> <p>Flex CouplerVKJF98036</p> <p>2020 GLS580:</p> <p>Flex CouplerVKJF98036</p> <p>2020 GLE580:</p> <p>Flex CouplerVKJF98036</p> <p>2019-2017 GLC43 AMG:</p> <p>Flex CouplerVKJF98028</p> <p>2019-2017 GLE43 AMG:</p> <p>Flex CouplerVKJF98033</p> <p>2019-2016 GLC300:</p> <p>Flex CouplerVKJF98028</p> <p>2018 GLE550e:</p> <p>Flex CouplerVKJF98032</p>	<p>Drive Shaft (Cont.)</p> <p>U-Joint (Cont.)</p> <p>2018-2014 GLA250:</p> <p>Flex CouplerVKJF98026</p> <p>2018-2014 GLA45 AMG:</p> <p>Flex CouplerVKJF98026</p>
--	--

Mercury (FWD) Topaz

<p>Drive Shaft</p> <p>U-Joint</p> <p>1991-1987 Topaz: [Type 45]</p> <p>U-Joint (Front)ⓁUJ437G</p> <p><i>Brute Force Greaseable</i>UJ240</p> <p><i>Brute Force Non Greaseable</i>UJ237</p> <p>Clamp Kit (Front)UJ437-10</p> <p>U-Joint (Center)ⓈUJ437G</p> <p><i>Brute Force Greaseable</i>UJ240</p> <p><i>Brute Force Non Greaseable</i>UJ237</p> <p>Clamp Kit (Center)UJ437-10</p> <p>U-Joint (Rear)ⓈUJ437G</p> <p><i>Brute Force Greaseable</i>UJ240</p> <p><i>Brute Force Non Greaseable</i>UJ237</p> <p>Clamp Kit (Rear)UJ437-10</p> <p>U-Joint (Rear Half Shaft)Ⓢ[2] UJ237</p>	
--	--

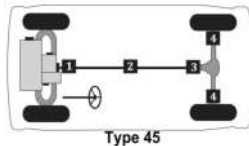

Passenger cars, light & medium trucks

Mercury (RWD) (Full Size), Brougham, Country Cruiser, Grand Marquis, Marauder, Montclair, Monterey (thru 1974), Park Lane, S-55, Turnpike Cruiser

MFG./YEAR	MODEL & LOCATION	PART NO.	MFG./YEAR	MODEL & LOCATION	PART NO.
Drive Shaft			Drive Shaft (Cont.)		
U-Joint			U-Joint (Cont.)		
2011-2006 Grand Marquis From 6/19/06: [Type 1]			2004-2003 Marauder w/ Alum. Driveshaft & 1.188" Brg. Caps: [Type 1]		
	U-Joint (Front)❶	UJ331		U-Joint (Front)❶	UJ331
	Brute Force Greaseable	UJ232		Brute Force Greaseable	UJ232
	Brute Force Non Greaseable	UJ231		Brute Force Non Greaseable	UJ231
	(For Aluminum Drive Shaft)	UJ331C		(For Aluminum Drive Shaft)	UJ331C
	U-Joint (Rear)❷	UJ331		U-Joint (Rear)❷	UJ331
	Brute Force Greaseable	UJ232		Brute Force Greaseable	UJ232
	Brute Force Non Greaseable	UJ231		Brute Force Non Greaseable	UJ231
	(For Aluminum Drive Shaft)	UJ331C		(For Aluminum Drive Shaft)	UJ331C
2006-2003 Grand Marquis Thru 6/18/06 w/ Alum. Driveshaft & 1.063" Brg. Caps: [Type 1]			2004-2003 Marauder w/ Steel Driveshaft: [Type 1]		
	U-Joint (Front)❶	UJ354		U-Joint (Front)❶	UJ345
	Brute Force Greaseable	UJ270		U-Joint (Rear)❷	UJ345
	Brute Force Non Greaseable	UJ254		2002-1995 Grand Marquis: [Type 1]	
	(For Aluminum Drive Shaft)	UJ354C		U-Joint (Front)❶	UJ354
	U-Joint (Rear)❷	UJ354		Brute Force Greaseable	UJ270
	Brute Force Greaseable	UJ270		Brute Force Non Greaseable	UJ254
	Brute Force Non Greaseable	UJ254		(For Aluminum Drive Shaft)	UJ354C
	(For Aluminum Drive Shaft)	UJ354C		U-Joint (Rear)❷	UJ354
2006-2003 Grand Marquis Thru 6/18/06 w/ Alum. Driveshaft & 1.188" Brg. Caps: [Type 1]				Brute Force Greaseable	UJ270
	U-Joint (Front)❶	UJ331		Brute Force Non Greaseable	UJ254
	Brute Force Greaseable	UJ232		(For Aluminum Drive Shaft)	UJ354C
	Brute Force Non Greaseable	UJ231		1994-1979 Colony Park, Grand Marquis & Marquis w/ 3.5" Yoke: [Type 1]	
	(For Aluminum Drive Shaft)	UJ331C		U-Joint (Front)❶	UJ369
	U-Joint (Rear)❷	UJ331		Brute Force Greaseable	UJ280
	Brute Force Greaseable	UJ232		Brute Force Non Greaseable	UJ269
	Brute Force Non Greaseable	UJ231		(For Aluminum Drive Shaft)	UJ369C
	(For Aluminum Drive Shaft)	UJ331C		U-Joint (Rear)❷	UJ369
2006-2003 Grand Marquis Thru 6/18/06 w/ Steel Driveshaft: [Type 1]				Brute Force Greaseable	UJ280
	U-Joint (Front)❶	UJ345		Brute Force Non Greaseable	UJ269
	U-Joint (Rear)❷	UJ345		(For Aluminum Drive Shaft)	UJ369C
2004-2003 Marauder w/ Alum. Driveshaft & 1.063" Brg. Caps: [Type 1]				1994-1979 Colony Park, Grand Marquis & Marquis w/ 3.875" Yoke: [Type 1]	
	U-Joint (Front)❶	UJ354		U-Joint (Front)❶	UJ354
	Brute Force Greaseable	UJ270		Brute Force Greaseable	UJ270
	Brute Force Non Greaseable	UJ254		Brute Force Non Greaseable	UJ254
	(For Aluminum Drive Shaft)	UJ354C		(For Aluminum Drive Shaft)	UJ354C
	U-Joint (Rear)❷	UJ354		U-Joint (Rear)❷	UJ354
	Brute Force Greaseable	UJ270		Brute Force Greaseable	UJ270
	Brute Force Non Greaseable	UJ254		Brute Force Non Greaseable	UJ254
	(For Aluminum Drive Shaft)	UJ354C		(For Aluminum Drive Shaft)	UJ354C
				1978-1977 Grand Marquis & Marquis w/ 3.5" Yoke: [Type 1]	
				U-Joint (Front)❶	UJ369
				Brute Force Greaseable	UJ280
				Brute Force Non Greaseable	UJ269
				(For Aluminum Drive Shaft)	UJ369C
				U-Joint (Rear)❷	UJ430
				Brute Force Greaseable	UJ255
				U-Bolt Kit (Rear)	UJ534-10
					(Continued)

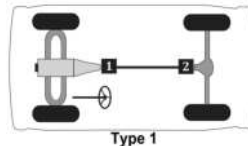

Passenger cars, light & medium trucks

Mercury (RWD) (Full Size), Brougham, Country Cruiser, Grand Marquis, Marauder, Montclair, Monterey (thru 1974), Park Lane, S-55, Turnpike Cruiser -- (Cont.)

MFG./YEAR	MODEL & LOCATION	PART NO.	MFG./YEAR	MODEL & LOCATION	PART NO.
Drive Shaft (Cont.)			Drive Shaft (Cont.)		
U-Joint (Cont.)			U-Joint (Cont.)		
1978-1977	Grand Marquis & Marquis w/ 3.875" Yoke: [Type 1]		1965	Colony Park, Marauder, Montclair, Monterey & Park Lane w/ 3.875" Yoke: [Type 1]	
	U-Joint (Front)⊙	UJ354		U-Joint (Front)⊙	UJ354
	Brute Force Greaseable	UJ270		Brute Force Greaseable	UJ270
	Brute Force Non Greaseable	UJ254		Brute Force Non Greaseable	UJ254
	(For Aluminum Drive Shaft)	UJ354C		(For Aluminum Drive Shaft)	UJ354C
	U-Joint (Rear)⊙	UJ434		U-Joint (Rear)⊙	UJ434
	Brute Force Greaseable	UJ265		Brute Force Greaseable	UJ265
	Brute Force Non Greaseable	UJ264		Brute Force Non Greaseable	UJ264
	U-Bolt Kit (Rear)	UJ534-10		U-Bolt Kit (Rear)	UJ534-10
1976-1966	Colony Park, Grand Marquis, Marquis & Monterey: [Type 1]		1964	Colony Park, Marauder, Montclair, Monterey & Park Lane: [Type 1]	
	U-Joint (Front)⊙	UJ354		U-Joint (Front)⊙	UJ354
	Brute Force Greaseable	UJ270		Brute Force Greaseable	UJ270
	Brute Force Non Greaseable	UJ254		Brute Force Non Greaseable	UJ254
	(For Aluminum Drive Shaft)	UJ354C		(For Aluminum Drive Shaft)	UJ354C
	U-Joint (Rear)⊙	UJ434		U-Joint (Rear)⊙	UJ434
	Brute Force Greaseable	UJ265		Brute Force Greaseable	UJ265
	Brute Force Non Greaseable	UJ264		Brute Force Non Greaseable	UJ264
	U-Bolt Kit (Rear)	UJ534-10		U-Bolt Kit (Rear)	UJ534-10
1970-1966	Marauder, Montclair, Park Lane & S-55: [Type 1]		1963	Country Cruiser & Marauder: [Type 1]	
	U-Joint (Front)⊙	UJ354		U-Joint (Front)⊙	UJ429
	Brute Force Greaseable	UJ270		Brute Force Greaseable	UJ250
	Brute Force Non Greaseable	UJ254		U-Joint (Rear)⊙	UJ430
	(For Aluminum Drive Shaft)	UJ354C		Brute Force Greaseable	UJ255
	U-Joint (Rear)⊙	UJ434		1963-1961 Colony Park, Meteor, Montclair & Monterey: [Type 1]	
	Brute Force Greaseable	UJ265		U-Joint (Front)⊙	UJ429
	Brute Force Non Greaseable	UJ264		Brute Force Greaseable	UJ250
	U-Bolt Kit (Rear)	UJ534-10		U-Joint (Rear)⊙	UJ430
1967	Brougham: [Type 1]			Brute Force Greaseable	UJ255
	U-Joint (Front)⊙	UJ354		U-Bolt Kit (Rear)	UJ534-10
	Brute Force Greaseable	UJ270	1960	Colony Park, Country Cruiser, Montclair, Monterey & Park Lane w/ 312 Eng.: [Type 1]	
	Brute Force Non Greaseable	UJ254		U-Joint (Front)⊙	UJ369
	(For Aluminum Drive Shaft)	UJ354C		Brute Force Greaseable	UJ280
	U-Joint (Rear)⊙	UJ434		Brute Force Non Greaseable	UJ269
	Brute Force Greaseable	UJ265		(For Aluminum Drive Shaft)	UJ369C
	Brute Force Non Greaseable	UJ264		U-Joint (Rear)⊙	UJ369
1965	Colony Park, Marauder, Montclair, Monterey & Park Lane w/ 3.5" Yoke: [Type 1]			Brute Force Greaseable	UJ280
	U-Joint (Front)⊙	UJ369		Brute Force Non Greaseable	UJ269
	Brute Force Greaseable	UJ280		(For Aluminum Drive Shaft)	UJ369C
	Brute Force Non Greaseable	UJ269		U-Bolt Kit (Rear)	UJ369C
	(For Aluminum Drive Shaft)	UJ369C			
	U-Joint (Rear)⊙	UJ430			
	Brute Force Greaseable	UJ255			
	U-Bolt Kit (Rear)	UJ534-10			

(Continued)

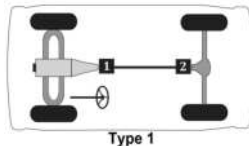

Passenger cars, light & medium trucks

(Cont.) -- Mercury (RWD) (Full Size), Brougham, Country Cruiser, Grand Marquis, Marauder, Montclair, Monterey (thru 1974), Park Lane, S-55, Turnpike Cruiser

MFG./YEAR	MODEL & LOCATION	PART NO.	MFG./YEAR	MODEL & LOCATION	PART NO.
Drive Shaft (Cont.)			Drive Shaft (Cont.)		
U-Joint (Cont.)			U-Joint (Cont.)		
1960	Colony Park, Country Cruiser, Montclair, Monterey & Park Lane w/ 383 & 430 Engs.: [Type 1]		1959-1955	Custom, Medalist, Montclair & Monterey: [Type 1]	
	U-Joint (Front)Ⓢ	UJ369		U-Joint (Front)Ⓢ	UJ369
	<i>Brute Force Greaseable</i>	UJ280		<i>Brute Force Greaseable</i>	UJ280
	<i>Brute Force Non Greaseable</i>	UJ269		<i>Brute Force Non Greaseable</i>	UJ269
	(For Aluminum Drive Shaft)	UJ369C		(For Aluminum Drive Shaft)	UJ369C
	U-Joint (Rear)Ⓢ	UJ353		U-Joint (Rear)Ⓢ	UJ369
	<i>Brute Force Greaseable</i>	UJ275		<i>Brute Force Greaseable</i>	UJ280
1959-1957	Colony Park, Country Cruiser, Park Lane & Turnpike Cruiser: [Type 1]			<i>Brute Force Non Greaseable</i>	UJ269
	U-Joint (Front)Ⓢ	UJ369		(For Aluminum Drive Shaft)	UJ369C
	<i>Brute Force Greaseable</i>	UJ280	1954-1950	Custom & Monterey: [Type 1]	
	<i>Brute Force Non Greaseable</i>	UJ269		U-Joint (Front)Ⓢ	UJ507
	(For Aluminum Drive Shaft)	UJ369C		U-Joint (Rear)Ⓢ	UJ12134
	U-Joint (Rear)Ⓢ	UJ369			
	<i>Brute Force Greaseable</i>	UJ280			
	<i>Brute Force Non Greaseable</i>	UJ269			
	(For Aluminum Drive Shaft)	UJ369C			

Mercury (RWD) Bobcat

Drive Shaft			Drive Shaft (Cont.)		
U-Joint			U-Joint (Cont.)		
1980	Bobcat: [Type 1]		1979-1975	Bobcat: [Type 1]	
	U-Joint (Front)Ⓢ	UJ369		U-Joint (Front)Ⓢ	UJ369
	<i>Brute Force Greaseable</i>	UJ280		<i>Brute Force Greaseable</i>	UJ280
	<i>Brute Force Non Greaseable</i>	UJ269		<i>Brute Force Non Greaseable</i>	UJ269
	(For Aluminum Drive Shaft)	UJ369C		(For Aluminum Drive Shaft)	UJ369C
	U-Joint (Rear)Ⓢ	UJ369		U-Joint (Rear)Ⓢ	UJ430
	<i>Brute Force Greaseable</i>	UJ280		<i>Brute Force Greaseable</i>	UJ255
	<i>Brute Force Non Greaseable</i>	UJ269		U-Bolt Kit (Rear)	UJ534-10
	(For Aluminum Drive Shaft)	UJ369C			

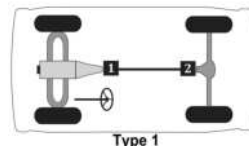

Type 1

Passenger cars, light & medium trucks

Mercury (RWD) Capri (thru 1986)

MFG./YEAR	MODEL & LOCATION	PART NO.	MFG./YEAR	MODEL & LOCATION	PART NO.
Drive Shaft					
U-Joint					
1986-1979 All: [Type 1]					
	U-Joint (Front)Ⓛ	UJ369			
	Brute Force Greaseable	UJ280			
	Brute Force Non Greaseable	UJ269			
	(For Aluminum Drive Shaft)	UJ369C			
	U-Joint (Rear)Ⓢ	UJ369			
	Brute Force Greaseable	UJ280			
	Brute Force Non Greaseable	UJ269			
	(For Aluminum Drive Shaft)	UJ369C			

Mercury (RWD) Caliente, Comet, Cyclone, Zephyr

MFG./YEAR	MODEL & LOCATION	PART NO.	MFG./YEAR	MODEL & LOCATION	PART NO.
Drive Shaft					
U-Joint					
1983-1978 Zephyr: [Type 1]					
	U-Joint (Front)Ⓛ	UJ369			
	Brute Force Greaseable	UJ280			
	Brute Force Non Greaseable	UJ269			
	(For Aluminum Drive Shaft)	UJ369C			
	U-Joint (Rear)Ⓢ	UJ369			
	Brute Force Greaseable	UJ280			
	Brute Force Non Greaseable	UJ269			
	(For Aluminum Drive Shaft)	UJ369C			
1977-1971 Comet & Cyclone: [Type 1]					
	U-Joint (Front)Ⓛ	UJ369			
	Brute Force Greaseable	UJ280			
	Brute Force Non Greaseable	UJ269			
	(For Aluminum Drive Shaft)	UJ369C			
	U-Joint (Rear)Ⓢ	UJ430			
	Brute Force Greaseable	UJ255			
	U-Bolt Kit (Rear)	UJ534-10			
1970-1968 Comet & Cyclone w/ 200, 250, 302 & 351 Eng.s.: [Type 1]					
	U-Joint (Front)Ⓛ	UJ369			
	Brute Force Greaseable	UJ280			
	Brute Force Non Greaseable	UJ269			
	(For Aluminum Drive Shaft)	UJ369C			
	U-Joint (Rear)Ⓢ	UJ430			
	Brute Force Greaseable	UJ255			
	U-Bolt Kit (Rear)	UJ534-10			
1970-1968 Comet & Cyclone w/ 390, 427 & 428 Eng.s.: [Type 1]					
	U-Joint (Front)Ⓛ	UJ354			
	Brute Force Greaseable	UJ270			
	Brute Force Non Greaseable	UJ254			
	(For Aluminum Drive Shaft)	UJ354C			
	U-Joint (Rear)Ⓢ	UJ434			
	Brute Force Greaseable	UJ265			
	Brute Force Non Greaseable	UJ264			
	U-Bolt Kit (Rear)	UJ534-10			
1967-1966 Caliente, Comet & Cyclone w/ 200 & 289 Eng.s.: [Type 1]					
	U-Joint (Front)Ⓛ	UJ369			
	Brute Force Greaseable	UJ280			
	Brute Force Non Greaseable	UJ269			
	(For Aluminum Drive Shaft)	UJ369C			
	U-Joint (Rear)Ⓢ	UJ430			
	Brute Force Greaseable	UJ255			
	U-Bolt Kit (Rear)	UJ534-10			
1967-1966 Caliente, Comet & Cyclone w/ 390 & 427 Eng.s.: [Type 1]					
	U-Joint (Front)Ⓛ	UJ354			
	Brute Force Greaseable	UJ270			
	Brute Force Non Greaseable	UJ254			
	(For Aluminum Drive Shaft)	UJ354C			
	U-Joint (Rear)Ⓢ	UJ434			
	Brute Force Greaseable	UJ265			
	Brute Force Non Greaseable	UJ264			
	U-Bolt Kit (Rear)	UJ534-10			
1965 Caliente, Comet & Cyclone w/ Auto. Trans.: [Type 1]					
	U-Joint (Front)Ⓛ	UJ369			
	Brute Force Greaseable	UJ280			
	Brute Force Non Greaseable	UJ269			
	(For Aluminum Drive Shaft)	UJ369C			
	U-Joint (Rear)Ⓢ	UJ430			
	Brute Force Greaseable	UJ255			
	U-Bolt Kit (Rear)	UJ534-10			
1965 Caliente, Comet & Cyclone w/ Man. Trans.: [Type 1]					
	U-Joint (Front)Ⓛ	UJ514G			
	U-Joint (Rear)Ⓢ	UJ514G			
1964-1963 Caliente, Comet & Cyclone w/ 144, 170 & 200 Eng.s.: [Type 1]					
	U-Joint (Front)Ⓛ	UJ514G			
	U-Joint (Rear)Ⓢ	UJ514G			

(Continued)

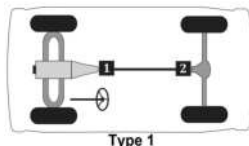

Passenger cars, light & medium trucks

(Cont.) -- Mercury (RWD) Caliente, Comet, Cyclone, Zephyr

MFG./YEAR	MODEL & LOCATION	PART NO.	MFG./YEAR	MODEL & LOCATION	PART NO.
Drive Shaft (Cont.)					
U-Joint (Cont.)					
1964-1963 Caliente, Comet & Cyclone w/ 260 & 289 Eng.s.: [Type 1]					
	U-Joint (Front)Ⓢ	UJ369			
	Brute Force Greaseable	UJ280			
	Brute Force Non Greaseable	UJ269			
	(For Aluminum Drive Shaft)	UJ369C			
	U-Joint (Rear)Ⓢ	UJ430			
	Brute Force Greaseable	UJ255			
	U-Bolt Kit (Rear)	UJ534-10			
1962-1960 Comet & Cyclone: [Type 1]					
	U-Joint (Front)Ⓢ	UJ514G			
	U-Joint (Rear)Ⓢ	UJ514G			

Mercury (RWD) Cougar (thru 1997)

MFG./YEAR	MODEL & LOCATION	PART NO.	MFG./YEAR	MODEL & LOCATION	PART NO.
Drive Shaft			Drive Shaft (Cont.)		
U-Joint			U-Joint (Cont.)		
1997-1994 Cougar: [Type 1]			1990-1989 Cougar w/ 3.5" Yoke: [Type 1]		
	U-Joint (Front)Ⓢ	UJ354		U-Joint (Front)Ⓢ	UJ369
	Brute Force Greaseable	UJ270		Brute Force Greaseable	UJ280
	Brute Force Non Greaseable	UJ254		Brute Force Non Greaseable	UJ269
	(For Aluminum Drive Shaft)	UJ354C		(For Aluminum Drive Shaft)	UJ369C
	U-Joint (Rear)Ⓢ	UJ354		U-Joint (Rear)Ⓢ	UJ369
	Brute Force Greaseable	UJ270		Brute Force Greaseable	UJ280
	Brute Force Non Greaseable	UJ254		Brute Force Non Greaseable	UJ269
	(For Aluminum Drive Shaft)	UJ354C		(For Aluminum Drive Shaft)	UJ369C
1993-1991 Cougar w/ 3.8L Eng.: [Type 1]			1990-1989 Cougar w/ 3.875" Yoke: [Type 1]		
	U-Joint (Front)Ⓢ	UJ369		U-Joint (Front)Ⓢ	UJ354
	Brute Force Greaseable	UJ280		Brute Force Greaseable	UJ270
	Brute Force Non Greaseable	UJ269		Brute Force Non Greaseable	UJ254
	(For Aluminum Drive Shaft)	UJ369C		(For Aluminum Drive Shaft)	UJ354C
	U-Joint (Rear)Ⓢ	UJ369		U-Joint (Rear)Ⓢ	UJ354
	Brute Force Greaseable	UJ280		Brute Force Greaseable	UJ270
	Brute Force Non Greaseable	UJ269		Brute Force Non Greaseable	UJ254
	(For Aluminum Drive Shaft)	UJ369C		(For Aluminum Drive Shaft)	UJ354C
1993-1991 Cougar w/ 5.0L Eng.: [Type 1]			1988-1983 Cougar: [Type 1]		
	U-Joint (Front)Ⓢ	UJ354		U-Joint (Front)Ⓢ	UJ369
	Brute Force Greaseable	UJ270		Brute Force Greaseable	UJ280
	Brute Force Non Greaseable	UJ254		Brute Force Non Greaseable	UJ269
	(For Aluminum Drive Shaft)	UJ354C		(For Aluminum Drive Shaft)	UJ369C
	U-Joint (Rear)Ⓢ	UJ354		U-Joint (Rear)Ⓢ	UJ369
	Brute Force Greaseable	UJ270		Brute Force Greaseable	UJ280
	Brute Force Non Greaseable	UJ254		Brute Force Non Greaseable	UJ269
	(For Aluminum Drive Shaft)	UJ354C		(For Aluminum Drive Shaft)	UJ369C

(Continued)

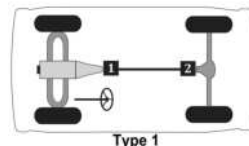

Passenger cars, light & medium trucks

Mercury (RWD) Cougar (thru 1997) -- (Cont.)

MFG./YEAR	MODEL & LOCATION	PART NO.	MFG./YEAR	MODEL & LOCATION	PART NO.
Drive Shaft (Cont.)			Drive Shaft (Cont.)		
U-Joint (Cont.)			U-Joint (Cont.)		
1982-1980 Cougar: [Type 1]			1974 Cougar: [Type 1]		
U-Joint (Front)⓪		UJ369	U-Joint (Front)⓪		UJ354
Brute Force Greaseable		UJ280	Brute Force Greaseable		UJ270
Brute Force Non Greaseable		UJ269	Brute Force Non Greaseable		UJ254
(For Aluminum Drive Shaft)		UJ369C	(For Aluminum Drive Shaft)		UJ354C
U-Joint (Rear)⓪	[2]	UJ379	U-Joint (Rear)⓪		UJ434
Brute Force Greaseable		UJ280	Brute Force Greaseable		UJ265
Brute Force Non Greaseable		UJ269	Brute Force Non Greaseable		UJ264
Centering Ball Kit		UJ612	U-Bolt Kit (Rear)		UJ534-10
Flange Yoke		UJ627	1973 Cougar: [Type 1]		
H Yoke		UJ647	U-Joint (Front)⓪		UJ369
1979 Cougar w/ Inner Lock Rings: [Type 1]			Brute Force Greaseable		UJ280
U-Joint (Front)⓪		UJ534G	Brute Force Non Greaseable		UJ269
Brute Force Greaseable		UJ235	(For Aluminum Drive Shaft)		UJ369C
Brute Force Non Greaseable		UJ234	U-Joint (Rear)⓪		UJ430
U-Joint (Rear)⓪		UJ375	Brute Force Greaseable		UJ255
U-Bolt Kit (Rear)		UJ534-10	U-Bolt Kit (Rear)		UJ534-10
1979 Cougar w/ Outer Lock Rings: [Type 1]			1972 Cougar: [Type 1]		
U-Joint (Front)⓪		UJ354	U-Joint (Front)⓪		UJ354
Brute Force Greaseable		UJ270	Brute Force Greaseable		UJ270
Brute Force Non Greaseable		UJ254	Brute Force Non Greaseable		UJ254
(For Aluminum Drive Shaft)		UJ354C	(For Aluminum Drive Shaft)		UJ354C
U-Joint (Rear)⓪		UJ434	U-Joint (Rear)⓪		UJ434
Brute Force Greaseable		UJ265	Brute Force Greaseable		UJ265
Brute Force Non Greaseable		UJ264	Brute Force Non Greaseable		UJ264
U-Bolt Kit (Rear)		UJ534-10	U-Bolt Kit (Rear)		UJ534-10
1978-1977 Cougar: [Type 1]			1971-1969 Cougar w/ Std. 302 & 351 Engs.: [Type 1]		
U-Joint (Front)⓪		UJ354	U-Joint (Front)⓪		UJ369
Brute Force Greaseable		UJ270	Brute Force Greaseable		UJ280
Brute Force Non Greaseable		UJ254	Brute Force Non Greaseable		UJ269
(For Aluminum Drive Shaft)		UJ354C	(For Aluminum Drive Shaft)		UJ369C
U-Joint (Rear)⓪		UJ434	U-Joint (Rear)⓪		UJ430
Brute Force Greaseable		UJ265	Brute Force Greaseable		UJ255
Brute Force Non Greaseable		UJ264	U-Bolt Kit (Rear)		UJ534-10
U-Bolt Kit (Rear)		UJ534-10	1971-1969 Cougar w/ Boss 302, 390, 428 & 429 Engs.: [Type 1]		
1976-1975 Cougar Exc. 351 Eng. & C4 Trans.: [Type 1]			U-Joint (Front)⓪		UJ354
U-Joint (Front)⓪		UJ354	Brute Force Greaseable		UJ270
Brute Force Greaseable		UJ270	Brute Force Non Greaseable		UJ254
Brute Force Non Greaseable		UJ254	(For Aluminum Drive Shaft)		UJ354C
(For Aluminum Drive Shaft)		UJ354C	U-Joint (Rear)⓪		UJ434
U-Joint (Rear)⓪		UJ434	Brute Force Greaseable		UJ265
Brute Force Greaseable		UJ265	Brute Force Non Greaseable		UJ264
Brute Force Non Greaseable		UJ264	U-Bolt Kit (Rear)		UJ534-10
U-Bolt Kit (Rear)		UJ534-10	1968-1967 Cougar w/ 289 & 302 Engs.: [Type 1]		
1976-1975 Cougar w/ 351 Eng. & C4 Trans.: [Type 1]			U-Joint (Front)⓪		UJ369
U-Joint (Front)⓪		UJ354	Brute Force Greaseable		UJ280
Brute Force Greaseable		UJ270	Brute Force Non Greaseable		UJ269
Brute Force Non Greaseable		UJ254	(For Aluminum Drive Shaft)		UJ369C
(For Aluminum Drive Shaft)		UJ354C	U-Joint (Rear)⓪		UJ430
U-Joint (Rear)⓪		UJ430	Brute Force Greaseable		UJ255
Brute Force Greaseable		UJ255	U-Bolt Kit (Rear)		UJ534-10
Brute Force Non Greaseable		UJ254			(Continued)
U-Bolt Kit (Rear)		UJ534-10			

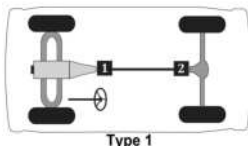

Passenger cars, light & medium trucks

(Cont.) -- Mercury (RWD) Cougar (thru 1997)

MFG./YEAR	MODEL & LOCATION	PART NO.	MFG./YEAR	MODEL & LOCATION	PART NO.
Drive Shaft (Cont.)					
U-Joint (Cont.)					
1968-1967 Cougar w/ 390, 427 & 428 Engs.:					
[Type 1]					
	U-Joint (Front)ⓈUJ354			
	<i>Brute Force Greaseable</i>UJ270			
	<i>Brute Force Non Greaseable</i>UJ254			
	(For Aluminum Drive Shaft)UJ354C			
	U-Joint (Rear)ⓈUJ434			
	<i>Brute Force Greaseable</i>UJ265			
	<i>Brute Force Non Greaseable</i>UJ264			
	U-Bolt Kit (Rear)UJ534-10			

Mercury (RWD) Marquis (from 1983), Monarch

MFG./YEAR	MODEL & LOCATION	PART NO.	MFG./YEAR	MODEL & LOCATION	PART NO.
Drive Shaft			Drive Shaft (Cont.)		
U-Joint			U-Joint (Cont.)		
1986-1983 Marquis w/ 3.5" Yoke: [Type 1]			1977-1975 Monarch w/ 3.5" Yoke: [Type 1]		
	U-Joint (Front)ⓈUJ369		U-Joint (Front)ⓈUJ369
	<i>Brute Force Greaseable</i>UJ280		<i>Brute Force Greaseable</i>UJ280
	<i>Brute Force Non Greaseable</i>UJ269		<i>Brute Force Non Greaseable</i>UJ269
	(For Aluminum Drive Shaft)UJ369C		(For Aluminum Drive Shaft)UJ369C
	U-Joint (Rear)ⓈUJ369		U-Joint (Rear)ⓈUJ430
	<i>Brute Force Greaseable</i>UJ280		<i>Brute Force Greaseable</i>UJ255
	<i>Brute Force Non Greaseable</i>UJ269		U-Bolt Kit (Rear)UJ534-10
	(For Aluminum Drive Shaft)UJ369C		1977-1975 Monarch w/ 3.875" Yoke: [Type 1]	
	1986-1983 Marquis w/ 3.875" Yoke: [Type 1]			U-Joint (Front)ⓈUJ354
	U-Joint (Front)ⓈUJ354		<i>Brute Force Greaseable</i>UJ270
	<i>Brute Force Greaseable</i>UJ270		<i>Brute Force Non Greaseable</i>UJ254
	<i>Brute Force Non Greaseable</i>UJ254		(For Aluminum Drive Shaft)UJ354C
	(For Aluminum Drive Shaft)UJ354C		U-Joint (Rear)ⓈUJ434
	U-Joint (Rear)ⓈUJ354		<i>Brute Force Greaseable</i>UJ265
	<i>Brute Force Greaseable</i>UJ270		<i>Brute Force Non Greaseable</i>UJ264
	<i>Brute Force Non Greaseable</i>UJ254		U-Bolt Kit (Rear)UJ534-10
	(For Aluminum Drive Shaft)UJ354C			
	1980-1978 Monarch: [Type 1]				
	U-Joint (Front)ⓈUJ369			
	<i>Brute Force Greaseable</i>UJ280			
	<i>Brute Force Non Greaseable</i>UJ269			
	(For Aluminum Drive Shaft)UJ369C			
	U-Joint (Rear)ⓈUJ430			
	<i>Brute Force Greaseable</i>UJ255			
	U-Bolt Kit (Rear)UJ534-10			

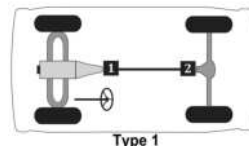

Passenger cars, light & medium trucks

Mercury (RWD) Montego (thru 1976)

MFG./YEAR	MODEL & LOCATION	PART NO.	MFG./YEAR	MODEL & LOCATION	PART NO.
Drive Shaft			Drive Shaft (Cont.)		
U-Joint			U-Joint (Cont.)		
1976-1975 Montego w/ 351 Modified Eng.: [Type 1]			1976-1975 Montego w/ 460 Eng.: [Type 1]		
	U-Joint (Front)Ⓛ	UJ354		U-Joint (Front)Ⓛ	UJ354
	Brute Force Greaseable	UJ270		Brute Force Greaseable	UJ270
	Brute Force Non Greaseable	UJ254		Brute Force Non Greaseable	UJ254
	(For Aluminum Drive Shaft)	UJ354C		(For Aluminum Drive Shaft)	UJ354C
	U-Joint (Rear)Ⓢ	UJ430		U-Joint (Rear)Ⓢ	UJ434
	Brute Force Greaseable	UJ255		Brute Force Greaseable	UJ265
	U-Bolt Kit (Rear)	UJ534-10		Brute Force Non Greaseable	UJ264
				U-Bolt Kit (Rear)	UJ534-10
1976-1975 Montego w/ 351 Windsor Eng.: [Type 1]			1974-1968 Montego w/ 3.5" Yoke: [Type 1]		
	U-Joint (Front)Ⓛ	UJ369		U-Joint (Front)Ⓛ	UJ369
	Brute Force Greaseable	UJ280		Brute Force Greaseable	UJ280
	Brute Force Non Greaseable	UJ269		Brute Force Non Greaseable	UJ269
	(For Aluminum Drive Shaft)	UJ369C		(For Aluminum Drive Shaft)	UJ369C
	U-Joint (Rear)Ⓢ	UJ430		U-Joint (Rear)Ⓢ	UJ430
	Brute Force Greaseable	UJ255		Brute Force Greaseable	UJ255
	U-Bolt Kit (Rear)	UJ534-10		U-Bolt Kit (Rear)	UJ534-10
1976-1975 Montego w/ 400 Eng.: [Type 1]			1974-1968 Montego w/ 3.875" Yoke: [Type 1]		
	U-Joint (Front)Ⓛ	UJ354		U-Joint (Front)Ⓛ	UJ354
	Brute Force Greaseable	UJ270		Brute Force Greaseable	UJ270
	Brute Force Non Greaseable	UJ254		Brute Force Non Greaseable	UJ254
	(For Aluminum Drive Shaft)	UJ354C		(For Aluminum Drive Shaft)	UJ354C
	U-Joint (Rear)Ⓢ	UJ430		U-Joint (Rear)Ⓢ	UJ434
	Brute Force Greaseable	UJ255		Brute Force Greaseable	UJ265
	U-Bolt Kit (Rear)	UJ534-10		Brute Force Non Greaseable	UJ264
				U-Bolt Kit (Rear)	UJ534-10

Metropolitan 1500, Series A, Series B

Drive Shaft	
U-Joint	
1962-1954 All: [Type 1]	
	U-Joint (Front)Ⓛ
	U-Joint (Rear)Ⓢ

MG

<table border="1" style="width: 100%; border-collapse: collapse;"> <tbody> <tr> <td colspan="2">Drive Shaft</td> </tr> <tr> <td colspan="2">U-Joint</td> </tr> <tr> <td colspan="2">1980-1954 MGA, MGB, MGBGT, Magnette, Midget & TF: [Type 1]</td> </tr> <tr> <td></td> <td>U-Joint (Front)Ⓛ</td> </tr> <tr> <td></td> <td>U-Joint (Rear)Ⓢ</td> </tr> </tbody> </table>	Drive Shaft		U-Joint		1980-1954 MGA, MGB, MGBGT, Magnette, Midget & TF: [Type 1]			U-Joint (Front)Ⓛ		U-Joint (Rear)Ⓢ	<table border="1" style="width: 100%; border-collapse: collapse;"> <tbody> <tr> <td colspan="2">Drive Shaft (Cont.)</td> </tr> <tr> <td colspan="2">U-Joint (Cont.)</td> </tr> <tr> <td colspan="2">1969-1968 MGC & MGC-GT: [Type 1]</td> </tr> <tr> <td></td> <td>U-Joint (Front)Ⓛ</td> </tr> <tr> <td></td> <td>Brute Force Greaseable</td> </tr> <tr> <td></td> <td>Brute Force Non Greaseable</td> </tr> <tr> <td></td> <td>(For Aluminum Drive Shaft)</td> </tr> <tr> <td></td> <td>U-Joint (Rear)Ⓢ</td> </tr> <tr> <td></td> <td>Brute Force Greaseable</td> </tr> <tr> <td></td> <td>Brute Force Non Greaseable</td> </tr> <tr> <td></td> <td>(For Aluminum Drive Shaft)</td> </tr> </tbody> </table>	Drive Shaft (Cont.)		U-Joint (Cont.)		1969-1968 MGC & MGC-GT: [Type 1]			U-Joint (Front)Ⓛ		Brute Force Greaseable		Brute Force Non Greaseable		(For Aluminum Drive Shaft)		U-Joint (Rear)Ⓢ		Brute Force Greaseable		Brute Force Non Greaseable		(For Aluminum Drive Shaft)
Drive Shaft																																	
U-Joint																																	
1980-1954 MGA, MGB, MGBGT, Magnette, Midget & TF: [Type 1]																																	
	U-Joint (Front)Ⓛ																																
	U-Joint (Rear)Ⓢ																																
Drive Shaft (Cont.)																																	
U-Joint (Cont.)																																	
1969-1968 MGC & MGC-GT: [Type 1]																																	
	U-Joint (Front)Ⓛ																																
	Brute Force Greaseable																																
	Brute Force Non Greaseable																																
	(For Aluminum Drive Shaft)																																
	U-Joint (Rear)Ⓢ																																
	Brute Force Greaseable																																
	Brute Force Non Greaseable																																
	(For Aluminum Drive Shaft)																																

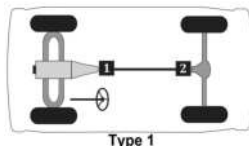

Passenger cars, light & medium trucks

Mitsubishi (RWD)

MFG./YEAR	MODEL & LOCATION	PART NO.	MFG./YEAR	MODEL & LOCATION	PART NO.
Drive Shaft					
U-Joint					
1990-1988 Van/Wgn.: [Type 1]					
	U-Joint (Front)ⓐ	UJ399			
	U-Joint (Rear)ⓐ	UJ399			
1989-1983 Starion: [Type 1]					
	U-Joint (Front)ⓐ	UJ399			
	U-Joint (Rear)ⓐ	UJ399			

Morris

Drive Shaft					
U-Joint					
1971-1950 Minor & Oxford: [Type 1]					
	U-Joint (Front)ⓐ	UJ340			
	U-Joint (Rear)ⓐ	UJ340			

Nissan (RWD), 350Z, 370Z

Drive Shaft					
U-Joint					
1998-1989 240SX: [Type 1]					
	U-Joint (Front)ⓐ	UJ10430			
	U-Joint (Rear)ⓐ	UJ10430			
1984-1978 200SX: [Type 1]					
	U-Joint (Front)ⓐ	UJ10430			
	U-Joint (Rear)ⓐ	UJ10430			
1983-1979 280ZX: [Type 10]					
	U-Joint (Front)ⓐ	UJ10430			
	U-Joint (Rear)ⓐ	UJ10430			
	U-Joint (Rear Half Shaft)ⓐ	[4] UJ393			
1980-1977 810: [Type 10]					
	U-Joint (Front)ⓐ	UJ10430			
	U-Joint (Rear)ⓐ	UJ10430			
	U-Joint (Rear Half Shaft)ⓐ	[4] UJ393			
1979-1978 510: [Type 1]					
	U-Joint (Front)ⓐ	UJ391			
	U-Joint (Rear)ⓐ	UJ391			
1978-1975 260Z & 280Z: [Type 12]					
	U-Joint (Rear Half Shaft)ⓐ	[4] UJ393			
1977-1974 710: [Type 1]					
	U-Joint (Front)ⓐ	UJ391			
	U-Joint (Rear)ⓐ	UJ391			
1977-1973 610: [Type 10]					
	U-Joint (Front)ⓐ	UJ391			
	U-Joint (Rear)ⓐ	UJ391			
	U-Joint (Rear Half Shaft)ⓐ	[4] UJ393			

Drive Shaft (Cont.)					
U-Joint (Cont.)					
1974-1970 240Z & 260Z: [Type 10]					
	U-Joint (Front)ⓐ	UJ391			
	U-Joint (Rear)ⓐ	UJ391			
	U-Joint (Rear Half Shaft)ⓐ	[4] UJ393			
1973-1970 B110: [Type 1]					
	U-Joint (Front)ⓐ	UJ392			
	U-Joint (Rear)ⓐ	UJ392			
1973-1968 510: [Type 10]					
	U-Joint (Front)ⓐ	UJ391			
	U-Joint (Rear)ⓐ	UJ391			
	U-Joint (Rear Half Shaft)ⓐ	[4] UJ393			
1967-1966 410 & 411 w/ 1.6L Eng.: [Type 1]					
	U-Joint (Front)ⓐ	UJ391			
	U-Joint (Rear)ⓐ	UJ391			
1967-1963 410 & 411 w/ 1.2L & 1.3L Eng.: [Type 1]					
	U-Joint (Front)ⓐ	UJ341			
	U-Joint (Rear)ⓐ	UJ341			

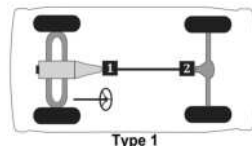

Type 1

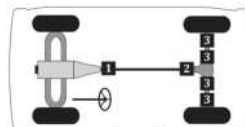

Type 10

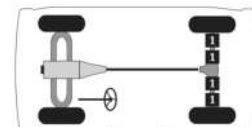

Type 12

Passenger cars, light & medium trucks

Oldsmobile (RWD) (Full Size), Custom Cruiser, Delta 88 (thru 1985), Dynamic, Jetstar, Starfire (thru 1966), 88 (thru 1985), 98 (thru 1984)

MFG./YEAR	MODEL & LOCATION	PART NO.	MFG./YEAR	MODEL & LOCATION	PART NO.
Drive Shaft			Drive Shaft (Cont.)		
U-Joint			U-Joint (Cont.)		
1985 Delta 88: [Type 1]			1972-1971 Delta 88 & 98 w/ "CV" at Rear Axle:		
			[Type 1]		
	U-Joint (Front)⓪	UJ534G		U-Joint (Front)⓪	UJ534G
	<i>Brute Force Greaseable</i>	UJ235		<i>Brute Force Greaseable</i>	UJ235
	<i>Brute Force Non Greaseable</i>	UJ234		<i>Brute Force Non Greaseable</i>	UJ234
	Clamp Kit (Front)	UJ530-10		U-Joint (Rear)⓪	[2] UJ534G
	U-Joint (Rear)⓪	UJ534G		<i>Brute Force Greaseable</i>	UJ235
	<i>Brute Force Greaseable</i>	UJ235		<i>Brute Force Non Greaseable</i>	UJ234
	<i>Brute Force Non Greaseable</i>	UJ234		1970-1968 Delta 88 w/ 350 Eng.: [Type 1]	
	Clamp Kit (Rear)	UJ530-10		U-Joint (Front)⓪	UJ534G
	1984-1982 Delta 88 & 98 w/ Inner Lock Rings:			<i>Brute Force Greaseable</i>	UJ235
	[Type 1]			<i>Brute Force Non Greaseable</i>	UJ234
	U-Joint (Front)⓪	UJ534G		U-Joint (Rear)⓪	UJ534G
	<i>Brute Force Greaseable</i>	UJ235		<i>Brute Force Greaseable</i>	UJ235
	<i>Brute Force Non Greaseable</i>	UJ234		<i>Brute Force Non Greaseable</i>	UJ234
	Clamp Kit (Front)	UJ530-10		1970-1968 Delta 88 & 98 w/ 455 Eng.: [Type 1]	
	U-Joint (Rear)⓪	UJ534G		U-Joint (Front)⓪	UJ354
	<i>Brute Force Greaseable</i>	UJ235		<i>Brute Force Greaseable</i>	UJ270
	<i>Brute Force Non Greaseable</i>	UJ234		<i>Brute Force Non Greaseable</i>	UJ254
	Clamp Kit (Rear)	UJ530-10		(For Aluminum Drive Shaft)	UJ354C
	1984-1982 Delta 88 & 98 w/ Outer Lock Rings:			U-Joint (Rear)⓪	UJ355
	[Type 1]			<i>Brute Force Greaseable</i>	UJ290
	U-Joint (Front)⓪	UJ331		(For Aluminum Drive Shaft)	UJ355C
	<i>Brute Force Greaseable</i>	UJ232		1967-1966 Delta 88, Jetstar 88 & 98 w/ Inner Lock	
	<i>Brute Force Non Greaseable</i>	UJ231		Rings: [Type 1]	
	(For Aluminum Drive Shaft)	UJ331C		U-Joint (Front)⓪	UJ534G
	U-Joint (Rear)⓪	UJ331		<i>Brute Force Greaseable</i>	UJ235
	<i>Brute Force Greaseable</i>	UJ232		<i>Brute Force Non Greaseable</i>	UJ234
	<i>Brute Force Non Greaseable</i>	UJ231		U-Joint (Rear)⓪	UJ534G
	(For Aluminum Drive Shaft)	UJ331C		<i>Brute Force Greaseable</i>	UJ235
	1981-1973 Delta 88 & 98 w/ "CV" at Rear Axle:			<i>Brute Force Non Greaseable</i>	UJ234
	[Type 1]			1967-1966 Delta 88, Jetstar 88 & 98 w/ Outer	
	U-Joint (Front)⓪	UJ534G		Lock Rings: [Type 1]	
	<i>Brute Force Greaseable</i>	UJ235		U-Joint (Front)⓪	UJ331
	<i>Brute Force Non Greaseable</i>	UJ234		<i>Brute Force Greaseable</i>	UJ232
	U-Joint (Rear)⓪	[2] UJ534G		<i>Brute Force Non Greaseable</i>	UJ231
	<i>Brute Force Greaseable</i>	UJ235		(For Aluminum Drive Shaft)	UJ331C
	<i>Brute Force Non Greaseable</i>	UJ234		U-Joint (Rear)⓪	UJ331
	Ball Seat Repair Kit	UJ606		<i>Brute Force Greaseable</i>	UJ232
	Flange Yoke	UJ626		<i>Brute Force Non Greaseable</i>	UJ231
	H Yoke	UJ646		(For Aluminum Drive Shaft)	UJ331C
	1981-1971 Delta 88 & 98 w/ 2 Joint Shaft: [Type			1965 Delta 88 & Jetstar 88 w/ Turbo	
	1]			Hydramatic Trans.: [Type 1]	
	U-Joint (Front)⓪	UJ534G		U-Joint (Front)⓪	UJ354
	<i>Brute Force Greaseable</i>	UJ235		<i>Brute Force Greaseable</i>	UJ270
	<i>Brute Force Non Greaseable</i>	UJ234		<i>Brute Force Non Greaseable</i>	UJ254
	Clamp Kit (Front)	UJ530-10		(For Aluminum Drive Shaft)	UJ354C
	U-Joint (Rear)⓪	UJ534G		U-Joint (Rear)⓪	UJ355
	<i>Brute Force Greaseable</i>	UJ235		<i>Brute Force Greaseable</i>	UJ290
	<i>Brute Force Non Greaseable</i>	UJ234		(For Aluminum Drive Shaft)	UJ355C
	Clamp Kit (Rear)	UJ530-10			(Continued)

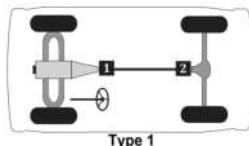

Passenger cars, light & medium trucks

(Cont.) -- Oldsmobile (RWD) (Full Size), Custom Cruiser, Delta 88 (thru 1985), Dynamic, Jetstar, Starfire (thru 1966), 88 (thru 1985), 98 (thru 1984)

MFG./YEAR	MODEL & LOCATION	PART NO.	MFG./YEAR	MODEL & LOCATION	PART NO.
Drive Shaft (Cont.)			Drive Shaft (Cont.)		
U-Joint (Cont.)			U-Joint (Cont.)		
1965	Delta 88 & Jetstar 88 Exc. Turbo Hydramatic Trans.: [Type 1]		1960-1959	Super 88 w/ Inner Lock Rings: [Type 2]	
	U-Joint (Front)⓪	UJ534G		U-Joint (Front)⓪	UJ534G
	Brute Force Greaseable	UJ235		Brute Force Greaseable	UJ235
	Brute Force Non Greaseable	UJ234		Brute Force Non Greaseable	UJ234
	U-Joint (Rear)⓪	UJ534G		U-Joint (Center)⓪	UJ534G
	Brute Force Greaseable	UJ235		Brute Force Greaseable	UJ235
	Brute Force Non Greaseable	UJ234		Brute Force Non Greaseable	UJ234
1965	98 w/ Turbo Hydramatic Trans.: [Type 1]			U-Joint (Rear)⓪	UJ534G
	U-Joint (Front)⓪	UJ354		Brute Force Greaseable	UJ235
	Brute Force Greaseable	UJ270		Brute Force Non Greaseable	UJ234
	Brute Force Non Greaseable	UJ254		1960-1959 Super 88 w/ Outer Lock Rings: [Type 2]	
	(For Aluminum Drive Shaft)	UJ354C		U-Joint (Front)⓪	UJ369
	U-Joint (Rear)⓪	UJ355		Brute Force Greaseable	UJ280
	Brute Force Greaseable	UJ290		Brute Force Non Greaseable	UJ269
	(For Aluminum Drive Shaft)	UJ355C		(For Aluminum Drive Shaft)	UJ369C
1965	98 Exc Turbo Hydramatic Trans.: [Type 1]			U-Joint (Center)⓪	UJ369
	U-Joint (Front)⓪	UJ534G		Brute Force Greaseable	UJ280
	Brute Force Greaseable	UJ235		Brute Force Non Greaseable	UJ269
	Brute Force Non Greaseable	UJ234		(For Aluminum Drive Shaft)	UJ369C
	U-Joint (Rear)⓪	UJ534G		U-Joint (Rear)⓪	UJ372
	Brute Force Greaseable	UJ235		(For Aluminum Drive Shaft)	UJ372C
	Brute Force Non Greaseable	UJ234		Clamp Kit (Rear)	UJ530-10
1964	98, Jetstar 88 & Super 88: [Type 1]			1958-1957 Super 88 w/ Inner Lock Rings: [Type 2]	
	U-Joint (Front)⓪	UJ534G		U-Joint (Front)⓪	UJ534G
	Brute Force Greaseable	UJ235		Brute Force Greaseable	UJ235
	Brute Force Non Greaseable	UJ234		Brute Force Non Greaseable	UJ234
	U-Joint (Rear)⓪	UJ534G		U-Joint (Center)⓪	UJ534G
	Brute Force Greaseable	UJ235		Brute Force Greaseable	UJ235
	Brute Force Non Greaseable	UJ234		Brute Force Non Greaseable	UJ234
1963-1961	Super 88 w/ Inner Lock Rings: [Type 1]			U-Joint (Rear)⓪	UJ534G
	U-Joint (Front)⓪	UJ534G		Brute Force Greaseable	UJ235
	Brute Force Greaseable	UJ235		Brute Force Non Greaseable	UJ234
	Brute Force Non Greaseable	UJ234		1958-1957 Super 88 w/ Outer Lock Rings: [Type 2]	
	U-Joint (Rear)⓪	UJ534G		U-Joint (Front)⓪	UJ372
	Brute Force Greaseable	UJ235		(For Aluminum Drive Shaft)	UJ372C
	Brute Force Non Greaseable	UJ234		Clamp Kit (Front)	UJ530-10
1963-1961	Super 88 w/ Outer Lock Rings: [Type 1]			U-Joint (Center)⓪	UJ369
	U-Joint (Front)⓪	UJ369		Brute Force Greaseable	UJ280
	Brute Force Greaseable	UJ280		Brute Force Non Greaseable	UJ269
	Brute Force Non Greaseable	UJ269		(For Aluminum Drive Shaft)	UJ369C
	(For Aluminum Drive Shaft)	UJ369C		U-Joint (Rear)⓪	UJ372
	U-Joint (Rear)⓪	UJ372		(For Aluminum Drive Shaft)	UJ372C
	(For Aluminum Drive Shaft)	UJ372C		Clamp Kit (Rear)	UJ530-10
	Clamp Kit (Rear)	UJ530-10		1956-1954 Super 88 w/ Auto. Trans.: [Type 1]	
				U-Joint (Front)⓪	UJ534G
				Brute Force Greaseable	UJ235
				Brute Force Non Greaseable	UJ234
				U-Joint (Rear)⓪	UJ531G

(Continued)

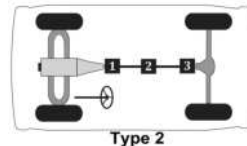
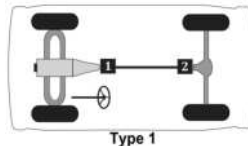

Passenger cars, light & medium trucks

Oldsmobile (RWD) (Full Size), Custom Cruiser, Delta 88 (thru 1985), Dynamic, Jetstar, Starfire (thru 1966), 88 (thru 1985), 98 (thru 1984) -- (Cont.)

MFG./YEAR	MODEL & LOCATION	PART NO.	MFG./YEAR	MODEL & LOCATION	PART NO.
Drive Shaft (Cont.)					
U-Joint (Cont.)					
1956-1954 Super 88 w/ Man. Trans.: [Type 4]					
	U-Joint (Front)Ⓛ	UJ507			
1953 Super 88: [Type 4]					
	U-Joint (Front)Ⓛ	UJ507			

Oldsmobile (RWD) Cutlass (thru 1987), Cutlass Calais, Cutlass Cruiser, Cutlass Salon, Cutlass Supreme (thru 1987), F-85, Vista Cruiser, 4-4-2

Drive Shaft	
U-Joint	
1988 Cutlass Supreme Classic: [Type 1]	
U-Joint (Front)Ⓛ	UJ534G
Brute Force Greaseable	UJ235
Brute Force Non Greaseable	UJ234
Clamp Kit (Front)	UJ530-10
U-Joint (Rear)Ⓢ	UJ534G
Brute Force Greaseable	UJ235
Brute Force Non Greaseable	UJ234
Clamp Kit (Rear)	UJ530-10
1987-1985 Cutlass: [Type 1]	
U-Joint (Front)Ⓛ	UJ534G
Brute Force Greaseable	UJ235
Brute Force Non Greaseable	UJ234
Clamp Kit (Front)	UJ530-10
U-Joint (Rear)Ⓢ	UJ534G
Brute Force Greaseable	UJ235
Brute Force Non Greaseable	UJ234
Clamp Kit (Rear)	UJ530-10
1984-1982 Cutlass w/ Inner Lock Rings: [Type 1]	
U-Joint (Front)Ⓛ	UJ534G
Brute Force Greaseable	UJ235
Brute Force Non Greaseable	UJ234
Clamp Kit (Front)	UJ530-10
U-Joint (Rear)Ⓢ	UJ534G
Brute Force Greaseable	UJ235
Brute Force Non Greaseable	UJ234
Clamp Kit (Rear)	UJ530-10
1984-1982 Cutlass w/ Outer Lock Rings: [Type 1]	
U-Joint (Front)Ⓛ	UJ331
Brute Force Greaseable	UJ232
Brute Force Non Greaseable	UJ231
(For Aluminum Drive Shaft)	UJ331C
U-Joint (Rear)Ⓢ	UJ331
Brute Force Greaseable	UJ232
Brute Force Non Greaseable	UJ231
(For Aluminum Drive Shaft)	UJ331C

Drive Shaft (Cont.)	
U-Joint (Cont.)	
1981-1971 Cutlass, F85, 442 & Vista Cruiser: [Type 1]	
U-Joint (Front)Ⓛ	UJ534G
Brute Force Greaseable	UJ235
Brute Force Non Greaseable	UJ234
Clamp Kit (Front)	UJ530-10
U-Joint (Rear)Ⓢ	UJ534G
Brute Force Greaseable	UJ235
Brute Force Non Greaseable	UJ234
Clamp Kit (Rear)	UJ530-10
1970-1968 Cutlass, F85, 442 & Vista Cruiser w/ 250, 350 & 400 Eng.: [Type 1]	
U-Joint (Front)Ⓛ	UJ534G
Brute Force Greaseable	UJ235
Brute Force Non Greaseable	UJ234
U-Joint (Rear)Ⓢ	UJ534G
Brute Force Greaseable	UJ235
Brute Force Non Greaseable	UJ234
1970-1968 Cutlass, F85, 442 & Vista Cruiser w/ 455 Eng.: [Type 1]	
U-Joint (Front)Ⓛ	UJ354
Brute Force Greaseable	UJ270
Brute Force Non Greaseable	UJ254
(For Aluminum Drive Shaft)	UJ354C
U-Joint (Rear)Ⓢ	UJ355
Brute Force Greaseable	UJ290
(For Aluminum Drive Shaft)	UJ355C
1967-1966 Cutlass, F85, 442 & Vista Cruiser w/ Inner Lock Rings: [Type 1]	
U-Joint (Front)Ⓛ	UJ534G
Brute Force Greaseable	UJ235
Brute Force Non Greaseable	UJ234
U-Joint (Rear)Ⓢ	UJ534G
Brute Force Greaseable	UJ235
Brute Force Non Greaseable	UJ234
(Continued)	

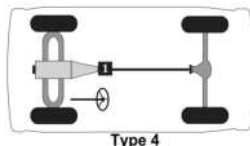
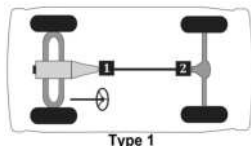

Passenger cars, light & medium trucks

(Cont.) -- Oldsmobile (RWD) Cutlass (thru 1987), Cutlass Calais, Cutlass Cruiser, Cutlass Salon, Cutlass Supreme (thru 1987), F-85, Vista Cruiser, 4-4-2

MFG./YEAR	MODEL & LOCATION	PART NO.	MFG./YEAR	MODEL & LOCATION	PART NO.
Drive Shaft (Cont.)			Drive Shaft (Cont.)		
U-Joint (Cont.)			U-Joint (Cont.)		
1967-1966 Cutlass, F85, 442 & Vista Cruiser w/ Outer Lock Rings: [Type 1]			1964 Cutlass, F85, 442 & Vista Cruiser: [Type 1]		
	U-Joint (Front)❶	UJ331		U-Joint (Front)❶	UJ534G
	Brute Force Greaseable	UJ232		Brute Force Greaseable	UJ235
	Brute Force Non Greaseable	UJ231		Brute Force Non Greaseable	UJ234
	(For Aluminum Drive Shaft)	UJ331C		U-Joint (Rear)❷	UJ534G
	U-Joint (Rear)❷	UJ331		Brute Force Greaseable	UJ235
	Brute Force Greaseable	UJ232		Brute Force Non Greaseable	UJ234
	Brute Force Non Greaseable	UJ231	1963-1961 Cutlass, F85 & Jetfire: [Type 5]		
	(For Aluminum Drive Shaft)	UJ331C		U-Joint (Fr. Shaft; Frt.)❶	UJ507
1965	Cutlass, F85, 442 & Vista Cruiser w/ Turbo Hydramatic Trans.: [Type 1]			U-Joint (Fr. Shaft; Rr.)❷	UJ515
	U-Joint (Front)❶	UJ354		U-Joint (Rr. Shaft; Frt.)❸	UJ515
	Brute Force Greaseable	UJ270		U-Joint (Rr. Shaft; Rr.)❹	UJ507
	Brute Force Non Greaseable	UJ254			
	(For Aluminum Drive Shaft)	UJ354C			
	U-Joint (Rear)❷	UJ355			
	Brute Force Greaseable	UJ290			
	(For Aluminum Drive Shaft)	UJ355C			
1965	Cutlass, F85, 442 & Vista Cruiser Exc. Turbo Hydramatic Trans.: [Type 1]				
	U-Joint (Front)❶	UJ534G			
	Brute Force Greaseable	UJ235			
	Brute Force Non Greaseable	UJ234			
	U-Joint (Rear)❷	UJ534G			
	Brute Force Greaseable	UJ235			
	Brute Force Non Greaseable	UJ234			

Oldsmobile (RWD) Omega (thru 1979), Starfire (from 1975)

Drive Shaft			Drive Shaft (Cont.)		
U-Joint			U-Joint (Cont.)		
1980-1977 All: [Type 1]			1976 5 Spd. Man. Trans.: [Type 1]		
	U-Joint (Front)❶	UJ369		U-Joint (Front)❶	UJ534G
	Brute Force Greaseable	UJ280		Brute Force Greaseable	UJ235
	Brute Force Non Greaseable	UJ269		Brute Force Non Greaseable	UJ234
	(For Aluminum Drive Shaft)	UJ369C		Clamp Kit (Front)	UJ530-10
	U-Bolt Kit (Front)	UJ329-10		U-Joint (Rear)❷	UJ534G
	U-Joint (Rear)❷	UJ369		Brute Force Greaseable	UJ235
	Brute Force Greaseable	UJ280		Brute Force Non Greaseable	UJ234
	Brute Force Non Greaseable	UJ269		Clamp Kit (Rear)	UJ530-10
	(For Aluminum Drive Shaft)	UJ369C			(Continued)
	U-Bolt Kit (Rear)	UJ329-10			

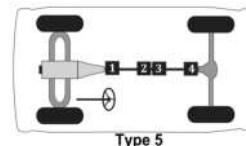
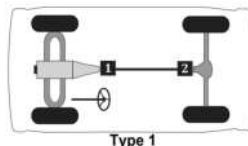

Passenger cars, light & medium trucks

Oldsmobile (RWD) Omega (thru 1979), Starfire (from 1975) -- (Cont.)

MFG./YEAR	MODEL & LOCATION	PART NO.	MFG./YEAR	MODEL & LOCATION	PART NO.
Drive Shaft (Cont.)			Drive Shaft (Cont.)		
U-Joint (Cont.)			U-Joint (Cont.)		
1976 Exc. 5 Spd. Man. Trans.: [Type 1]			1975-1973 All: [Type 1]		
	U-Joint (Front)Ⓛ	UJ369		U-Joint (Front)Ⓛ	UJ369
	Brute Force Greaseable	UJ280		Brute Force Greaseable	UJ280
	Brute Force Non Greaseable	UJ269		Brute Force Non Greaseable	UJ269
	(For Aluminum Drive Shaft)	UJ369C		(For Aluminum Drive Shaft)	UJ369C
	U-Bolt Kit (Front)	UJ329-10		U-Bolt Kit (Front)	UJ329-10
	U-Joint (Rear)Ⓢ	UJ369		U-Joint (Rear)Ⓢ	UJ369
	Brute Force Greaseable	UJ280		Brute Force Greaseable	UJ280
	Brute Force Non Greaseable	UJ269		Brute Force Non Greaseable	UJ269
	(For Aluminum Drive Shaft)	UJ369C		(For Aluminum Drive Shaft)	UJ369C
	U-Bolt Kit (Rear)	UJ329-10		U-Bolt Kit (Rear)	UJ329-10

Plymouth (RWD) Arrow, Conquest, Cricket, Sapporo

<p>Drive Shaft</p> <p>U-Joint</p> <p>1986-1984 Conquest : [Type 1]</p> <p>U-Joint (Front)Ⓛ UJ399</p> <p>U-Joint (Rear)Ⓢ UJ399</p> <p>1983-1981 Sapporo w/ Auto. Trans.: [Type 2]</p> <p>U-Joint (Front)Ⓛ UJ398</p> <p>U-Joint (Center)Ⓢ UJ398</p> <p>U-Joint (Rear)Ⓢ UJ398</p> <p>1983-1981 Sapporo w/ Man. Trans.: [Type 2]</p> <p>U-Joint (Front)Ⓛ UJ399</p> <p>U-Joint (Center)Ⓢ UJ399</p> <p>U-Joint (Rear)Ⓢ UJ399</p> <p>1980-1979 Arrow w/ 1.6L Eng.: [Type 1]</p> <p>U-Joint (Front)Ⓛ UJ398</p> <p>U-Joint (Rear)Ⓢ UJ398</p> <p>1980-1979 Arrow w/ 2.6L Eng.: [Type 1]</p> <p>U-Joint (Front)Ⓛ UJ399</p> <p>U-Joint (Rear)Ⓢ UJ399</p>	<p>Drive Shaft (Cont.)</p> <p>U-Joint (Cont.)</p> <p>1980-1978 Sapporo: [Type 1]</p> <p>U-Joint (Front)Ⓛ UJ399</p> <p>U-Joint (Rear)Ⓢ UJ399</p> <p>1978-1976 Arrow: [Type 1]</p> <p>U-Joint (Front)Ⓛ UJ398</p> <p>U-Joint (Rear)Ⓢ UJ398</p> <p>1973-1971 Cricket: [Type 1]</p> <p>U-Joint (Front)Ⓛ UJ341</p> <p>U-Joint (Rear)Ⓢ UJ341</p>
--	---

Plymouth (RWD) Barracuda, Duster, Scamp, Valiant, Volare

<p>Drive Shaft</p> <p>U-Joint</p> <p>1980-1970 Duster, Scamp, Valiant & Volare:</p> <p style="padding-left: 20px;">[Type 1]</p> <p>U-Joint (Front)Ⓛ UJ315G</p> <p>Brute Force Greaseable UJ246</p> <p>Clamp Kit (Front) UJ318-10</p> <p>U-Joint (Rear)Ⓢ UJ315G</p> <p>Brute Force Greaseable UJ246</p> <p>Clamp Kit (Rear) UJ318-10</p>	<p>Drive Shaft (Cont.)</p> <p>U-Joint (Cont.)</p> <p>1973-1968 Barracuda w/ 2.125" Yoke: [Type 1]</p> <p>U-Joint (Front)Ⓛ UJ315G</p> <p>Brute Force Greaseable UJ246</p> <p>Clamp Kit (Front) UJ318-10</p> <p>U-Joint (Rear)Ⓢ UJ315G</p> <p>Brute Force Greaseable UJ246</p> <p>Clamp Kit (Rear) UJ318-10</p> <p style="text-align: right;">(Continued)</p>
---	---

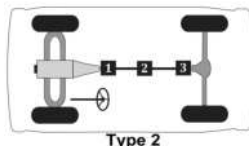
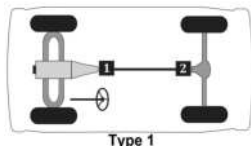

Passenger cars, light & medium trucks

(Cont.) -- Plymouth (RWD) Barracuda, Duster, Scamp, Valiant, Volare

MFG./YEAR	MODEL & LOCATION	PART NO.	MFG./YEAR	MODEL & LOCATION	PART NO.
Drive Shaft (Cont.)			Drive Shaft (Cont.)		
U-Joint (Cont.)			U-Joint (Cont.)		
1973-1968 Barracuda w/ 2.625" Yoke: [Type 1]			1967-1966 Barracuda: [Type 1]		
	U-Joint (Front) ❶	UJ316		U-Joint (Front) ❶	UJ315G
	Brute Force Greaseable	UJ248		Brute Force Greaseable	UJ246
	Clamp Kit (Front)	UJ316-10		Clamp Kit (Front)	UJ318-10
	U-Joint (Rear) ❷	UJ316		U-Joint (Rear) ❷	UJ315G
	Brute Force Greaseable	UJ248		Brute Force Greaseable	UJ246
	Clamp Kit (Rear)	UJ316-10		Clamp Kit (Rear)	UJ318-10
1969-1966 Valiant w/ 2.125" Yoke: [Type 1]			1965-1960 Valiant: [Type 7]		
	U-Joint (Front) ❶	UJ315G		U-Joint (Rear) ❷	UJ315G
	Brute Force Greaseable	UJ246		Brute Force Greaseable	UJ246
	Clamp Kit (Front)	UJ318-10			
	U-Joint (Rear) ❷	UJ315G			
	Brute Force Greaseable	UJ246			
	Clamp Kit (Rear)	UJ318-10			
1969-1966 Valiant w/ 2.625" Yoke: [Type 1]					
	U-Joint (Front) ❶	UJ316			
	Brute Force Greaseable	UJ248			
	Clamp Kit (Front)	UJ316-10			
	U-Joint (Rear) ❷	UJ316			
	Brute Force Greaseable	UJ248			
	Clamp Kit (Rear)	UJ316-10			

Plymouth (RWD) Belvedere, Fury, Gran Fury, Road Runner, Satellite

Drive Shaft			Drive Shaft (Cont.)		
U-Joint			U-Joint (Cont.)		
1989-1986 Gran Fury: [Type 1]			1978-1968 Belvedere, Fury, Gran Fury, Road Runner & Satellite w/ 2.625" Yoke: [Type 1]		
	U-Joint (Front) ❶	UJ317		U-Joint (Front) ❶	UJ316
	Brute Force Greaseable	UJ246		Brute Force Greaseable	UJ248
	Clamp Kit (Front)	UJ318-10		U-Joint (Rear) ❷	UJ316
	U-Joint (Rear) ❷	UJ317		Brute Force Greaseable	UJ248
	Brute Force Greaseable	UJ246		1967-1966 Belvedere, Fury & Satellite w/ 225, 273, 318 & 383 Engs.: [Type 1]	
	Clamp Kit (Rear)	UJ318-10		U-Joint (Front) ❶	UJ315G
1985-1980 Gran Fury: [Type 1]				Brute Force Greaseable	UJ246
	U-Joint (Front) ❶	UJ315G		Clamp Kit (Front)	UJ318-10
	Brute Force Greaseable	UJ246		U-Joint (Rear) ❷	UJ315G
	Clamp Kit (Front)	UJ318-10		Brute Force Greaseable	UJ246
	U-Joint (Rear) ❷	UJ315G		Clamp Kit (Rear)	UJ318-10
	Brute Force Greaseable	UJ246		1967-1966 Belvedere, Fury & Satellite w/ 426 & 440 Engs. & Inner Lock Rings: [Type 1]	
	Clamp Kit (Rear)	UJ318-10		U-Joint (Front) ❶	UJ316
1978-1968 Belvedere, Fury, Gran Fury, Road Runner & Satellite w/ 2.125" Yoke: [Type 1]				Brute Force Greaseable	UJ248
	U-Joint (Front) ❶	UJ315G		U-Joint (Rear) ❷	UJ354
	Brute Force Greaseable	UJ246		Brute Force Greaseable	UJ270
	Clamp Kit (Front)	UJ318-10		Brute Force Non Greaseable	UJ254
	U-Joint (Rear) ❷	UJ315G		(For Aluminum Drive Shaft)	UJ354C
	Brute Force Greaseable	UJ246			
	Clamp Kit (Rear)	UJ318-10			

(Continued)

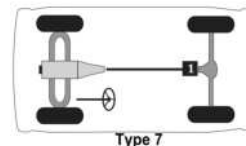
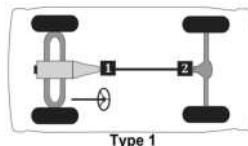

Passenger cars, light & medium trucks

Plymouth (RWD) Belvedere, Fury, Gran Fury, Road Runner, Satellite -- (Cont.)

MFG./YEAR	MODEL & LOCATION	PART NO.	MFG./YEAR	MODEL & LOCATION	PART NO.
-----------	------------------	----------	-----------	------------------	----------

Drive Shaft (Cont.)

U-Joint (Cont.)

1967-1966 Belvedere, Fury & Satellite w/ 426 & 440 Eng. & Outer Lock Rings: [Type 1]

U-Joint (Front)⊙	UJ354
Brute Force Greaseable	UJ270
Brute Force Non Greaseable	UJ254
(For Aluminum Drive Shaft)	UJ354C
U-Joint (Rear)⊙	UJ354
Brute Force Greaseable	UJ270
Brute Force Non Greaseable	UJ254
(For Aluminum Drive Shaft)	UJ354C

Pontiac (FWD) 6000

Drive Shaft

U-Joint

1990-1989 6000 w/ AWD: [Type 43]

U-Joint (Center)⊙	[2] UJ437G
Brute Force Greaseable	UJ240
Brute Force Non Greaseable	UJ237
Clamp Kit (Center)	[2] UJ437-10
U-Joint (Rear)⊙	UJ534G
Brute Force Greaseable	UJ235
Brute Force Non Greaseable	UJ234

Pontiac (RWD) Astre, Phoenix (thru 1979), Sunbird (thru 1980), Ventura II

Drive Shaft

U-Joint

1980-1976 Sunbird: [Type 1]

U-Joint (Front)⊙	UJ369
Brute Force Greaseable	UJ280
Brute Force Non Greaseable	UJ269
(For Aluminum Drive Shaft)	UJ369C
U-Bolt Kit (Front)	UJ329-10
U-Joint (Rear)⊙	UJ369
Brute Force Greaseable	UJ280
Brute Force Non Greaseable	UJ269
(For Aluminum Drive Shaft)	UJ369C
U-Bolt Kit (Rear)	UJ329-10

Drive Shaft (Cont.)

U-Joint (Cont.)

1979-1977 Phoenix: [Type 1]

U-Joint (Front)⊙	UJ369
Brute Force Greaseable	UJ280
Brute Force Non Greaseable	UJ269
(For Aluminum Drive Shaft)	UJ369C
Clamp Kit (Front)	UJ360-10
U-Joint (Rear)⊙	UJ369
Brute Force Greaseable	UJ280
Brute Force Non Greaseable	UJ269
(For Aluminum Drive Shaft)	UJ369C
Clamp Kit (Rear)	UJ360-10

1977 Ventura w/ Inner Lock Rings: [Type 1]

U-Joint (Front)⊙	UJ534G
Brute Force Greaseable	UJ235
Brute Force Non Greaseable	UJ234
U-Joint (Rear)⊙	UJ534G
Brute Force Greaseable	UJ235
Brute Force Non Greaseable	UJ234

(Continued)

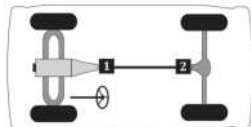

Type 1

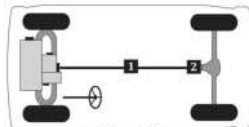

Type 43

Passenger cars, light & medium trucks

(Cont.) -- Pontiac (RWD) Astre, Phoenix (thru 1979), Sunbird (thru 1980), Ventura II

MFG./YEAR	MODEL & LOCATION	PART NO.	MFG./YEAR	MODEL & LOCATION	PART NO.
Drive Shaft (Cont.)			Drive Shaft (Cont.)		
U-Joint (Cont.)			U-Joint (Cont.)		
1977	Ventura w/ Outer Lock Rings: [Type 1]		1976-1971	Ventura: [Type 1]	
	U-Joint (Front)⓪	UJ369		U-Joint (Front)⓪	UJ369
	Brute Force Greaseable	UJ280		Brute Force Greaseable	UJ280
	Brute Force Non Greaseable	UJ269		Brute Force Non Greaseable	UJ269
	(For Aluminum Drive Shaft)	UJ369C		(For Aluminum Drive Shaft)	UJ369C
	Clamp Kit (Front)	UJ360-10		Clamp Kit (Front)	UJ360-10
	U-Joint (Rear)⓪	UJ369		U-Joint (Rear)⓪	UJ369
	Brute Force Greaseable	UJ280		Brute Force Greaseable	UJ280
	Brute Force Non Greaseable	UJ269		Brute Force Non Greaseable	UJ269
	(For Aluminum Drive Shaft)	UJ369C		(For Aluminum Drive Shaft)	UJ369C
	Clamp Kit (Rear)	UJ360-10		Clamp Kit (Rear)	UJ360-10
1977-1975 Astre: [Type 1]					
	U-Joint (Front)⓪	UJ369			
	Brute Force Greaseable	UJ280			
	Brute Force Non Greaseable	UJ269			
	(For Aluminum Drive Shaft)	UJ369C			
	U-Bolt Kit (Front)	UJ329-10			
	U-Joint (Rear)⓪	UJ369			
	Brute Force Greaseable	UJ280			
	Brute Force Non Greaseable	UJ269			
	(For Aluminum Drive Shaft)	UJ369C			
	U-Bolt Kit (Rear)	UJ329-10			

Pontiac (RWD) (Full Size), Bonneville (thru 1986), Catalina, Chieftan, Executive, Grand Prix (thru 1987), Grandville, Parisienne, Safari, Star Chief, Super Chief

Drive Shaft			Drive Shaft (Cont.)		
U-Joint			U-Joint (Cont.)		
1989-1987 Safari Wgn.: [Type 1]			1986-1985 Bonneville & Parisienne: [Type 1]		
	U-Joint (Front)⓪	UJ534G		U-Joint (Front)⓪	UJ534G
	Brute Force Greaseable	UJ235		Brute Force Greaseable	UJ235
	Brute Force Non Greaseable	UJ234		Brute Force Non Greaseable	UJ234
	Clamp Kit (Front)	UJ530-10		Clamp Kit (Front)	UJ530-10
	U-Joint (Rear)⓪	UJ534G		U-Joint (Rear)⓪	UJ534G
	Brute Force Greaseable	UJ235		Brute Force Greaseable	UJ235
	Brute Force Non Greaseable	UJ234		Brute Force Non Greaseable	UJ234
	Clamp Kit (Rear)	UJ530-10		Clamp Kit (Rear)	UJ530-10
1987-1985 Grand Prix: [Type 1]			1984-1982 Bonneville & Parisienne w/ Inner Lock Rings: [Type 1]		
	U-Joint (Front)⓪	UJ534G		U-Joint (Front)⓪	UJ534G
	Brute Force Greaseable	UJ235		Brute Force Greaseable	UJ235
	Brute Force Non Greaseable	UJ234		Brute Force Non Greaseable	UJ234
	Clamp Kit (Front)	UJ530-10		Clamp Kit (Front)	UJ530-10
	U-Joint (Rear)⓪	UJ534G		U-Joint (Rear)⓪	UJ534G
	Brute Force Greaseable	UJ235		Brute Force Greaseable	UJ235
	Brute Force Non Greaseable	UJ234		Brute Force Non Greaseable	UJ234
	Clamp Kit (Rear)	UJ530-10		Clamp Kit (Rear)	UJ530-10

(Continued)

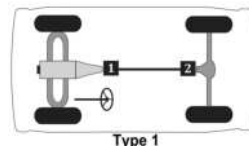

Passenger cars, light & medium trucks

Pontiac (RWD) (Full Size), Bonneville (thru 1986), Catalina, Chieftan, Executive, Grand Prix (thru 1987), Grandville, Parisienne, Safari, Star Chief, Super Chief -- (Cont.)

MFG./YEAR	MODEL & LOCATION	PART NO.	MFG./YEAR	MODEL & LOCATION	PART NO.
Drive Shaft (Cont.)			Drive Shaft (Cont.)		
U-Joint (Cont.)			U-Joint (Cont.)		
1984-1982 Grand Prix w/ Inner Lock Rings:			1981-1973 Grand Prix: [Type 1]		
[Type 1]					
	U-Joint (Front)ⓐ	UJ534G		U-Joint (Front)ⓐ	UJ534G
	Brute Force Greaseable	UJ235		Brute Force Greaseable	UJ235
	Brute Force Non Greaseable	UJ234		Brute Force Non Greaseable	UJ234
	Clamp Kit (Front)	UJ530-10		Clamp Kit (Front)	UJ530-10
	U-Joint (Rear)ⓑ	UJ534G		U-Joint (Rear)ⓑ	UJ534G
	Brute Force Greaseable	UJ235		Brute Force Greaseable	UJ235
	Brute Force Non Greaseable	UJ234		Brute Force Non Greaseable	UJ234
	Clamp Kit (Rear)	UJ530-10		Clamp Kit (Rear)	UJ530-10
1984-1982 Bonneville & Parisienne w/ Outer Lock Rings: [Type 1]			1981-1971 Bonneville, Catalina, Grandville & Parisienne w/ 2 Joint Shaft: [Type 1]		
[Type 1]			[Type 1]		
	U-Joint (Front)ⓐ	UJ331		U-Joint (Front)ⓐ	UJ534G
	Brute Force Greaseable	UJ232		Brute Force Greaseable	UJ235
	Brute Force Non Greaseable	UJ231		Brute Force Non Greaseable	UJ234
	(For Aluminum Drive Shaft)	UJ331C		Clamp Kit (Front)	UJ530-10
	U-Joint (Rear)ⓑ	UJ331		U-Joint (Rear)ⓑ	UJ534G
	Brute Force Greaseable	UJ232		Brute Force Greaseable	UJ235
	Brute Force Non Greaseable	UJ231		Brute Force Non Greaseable	UJ234
	(For Aluminum Drive Shaft)	UJ331C		Clamp Kit (Rear)	UJ530-10
1984-1982 Grand Prix w/ Outer Lock Rings:			1972-1971 Bonneville, Catalina, Grandville & Parisienne w/ "CV" at Rear Axle:		
[Type 1]			[Type 1]		
	U-Joint (Front)ⓐ	UJ331		U-Joint (Front)ⓐ	UJ534G
	Brute Force Greaseable	UJ232		Brute Force Greaseable	UJ235
	Brute Force Non Greaseable	UJ231		Brute Force Non Greaseable	UJ234
	(For Aluminum Drive Shaft)	UJ331C		U-Joint (Rear)ⓑ	UJ534G
	U-Joint (Rear)ⓑ	UJ331		Brute Force Greaseable	UJ235
	Brute Force Greaseable	UJ232		Brute Force Non Greaseable	UJ234
	Brute Force Non Greaseable	UJ231		1972-1962 Grand Prix: [Type 1]	
	(For Aluminum Drive Shaft)	UJ331C		U-Joint (Front)ⓐ	UJ534G
1981-1973 Bonneville, Catalina, Grandville & Parisienne w/ "CV" at Rear Axle:			1970-1961 Bonneville, Catalina, Executive, Parisienne, Safari & Star Chief: [Type 1]		
[Type 1]			[Type 1]		
	U-Joint (Front)ⓐ	UJ534G		U-Joint (Front)ⓐ	UJ534G
	Brute Force Greaseable	UJ235		Brute Force Greaseable	UJ235
	Brute Force Non Greaseable	UJ234		Brute Force Non Greaseable	UJ234
	U-Joint (Rear)ⓑ	UJ534G		U-Joint (Rear)ⓑ	UJ534G
	Brute Force Greaseable	UJ235		Brute Force Greaseable	UJ235
	Brute Force Non Greaseable	UJ234		Brute Force Non Greaseable	UJ234
	Ball Seat Repair Kit	UJ606		Brute Force Greaseable	UJ235
	Flange Yoke	UJ626		Brute Force Non Greaseable	UJ234
	H Yoke	UJ646		Brute Force Greaseable	UJ235
				Brute Force Non Greaseable	UJ234

(Continued)

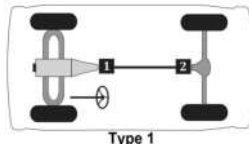

Passenger cars, light & medium trucks

(Cont.) -- Pontiac (RWD) (Full Size), Bonneville (thru 1986), Catalina, Chieftan, Executive, Grand Prix (thru 1987), Grandville, Parisienne, Safari, Star Chief, Super Chief

MFG./YEAR	MODEL & LOCATION	PART NO.	MFG./YEAR	MODEL & LOCATION	PART NO.
Drive Shaft (Cont.)			Drive Shaft (Cont.)		
U-Joint (Cont.)			U-Joint (Cont.)		
1960-1958 Bonneville, Catalina, Chieftan, Parisienne, Safari & Star Chief: [Type 2]			1957-1956 Bonneville, Catalina, Chieftan, Safari & Star Chief: [Type 1]		
	U-Joint (Front)Ⓢ	UJ534G		U-Joint (Front)Ⓢ	UJ534G
	Brute Force Greaseable	UJ235		Brute Force Greaseable	UJ235
	Brute Force Non Greaseable	UJ234		Brute Force Non Greaseable	UJ234
	U-Joint (Center)Ⓢ	UJ534G		U-Joint (Rear)Ⓢ	UJ534G
	Brute Force Greaseable	UJ235		Brute Force Greaseable	UJ235
	Brute Force Non Greaseable	UJ234		Brute Force Non Greaseable	UJ234
	U-Joint (Rear)Ⓢ	UJ534G	1955-1949 Catalina, Chieftan & Star Chief: [Type 1]		
	Brute Force Greaseable	UJ235		U-Joint (Front)Ⓢ	UJ507
	Brute Force Non Greaseable	UJ234		U-Joint (Rear)Ⓢ	UJ12134

Pontiac (RWD) Firebird, Grand Am (1973-1980), GTO, Le Mans (thru 1981), Tempest (1963-1970)





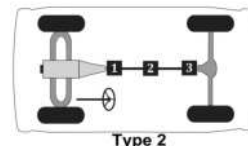
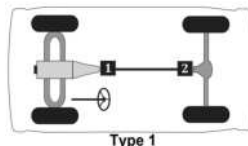















Drive Shaft			Drive Shaft (Cont.)		
U-Joint			U-Joint (Cont.)		
2006-2005 GTO:			1992-1988 Firebird w/ Steel Driveshaft: [Type 1]		
	Flex Coupler	VKJF98022		U-Joint (Front)Ⓢ	UJ534G
2004 GTO:				Brute Force Greaseable	UJ235
	Flex Coupler	VKJF98037		Brute Force Non Greaseable	UJ234
2002-1993 Firebird: [Type 1]				Clamp Kit (Front)	UJ530-10
	U-Joint (Front)Ⓢ	UJ534G		U-Joint (Rear)Ⓢ	UJ534G
	Brute Force Greaseable	UJ235		Brute Force Greaseable	UJ235
	Brute Force Non Greaseable	UJ234		Brute Force Non Greaseable	UJ234
	Clamp Kit (Front)	UJ530-10		Clamp Kit (Rear)	UJ530-10
	U-Joint (Rear)Ⓢ	UJ534G	1987-1985 Firebird: [Type 1]		
	Brute Force Greaseable	UJ235		U-Joint (Front)Ⓢ	UJ534G
	Brute Force Non Greaseable	UJ234		Brute Force Greaseable	UJ235
	Clamp Kit (Rear)	UJ530-10		Brute Force Non Greaseable	UJ234
1992-1988 Firebird w/ Alum. Driveshaft: [Type 1]				Clamp Kit (Front)	UJ530-10
	U-Joint (Front)Ⓢ	UJ369		U-Joint (Rear)Ⓢ	UJ534G
	Brute Force Greaseable	UJ280		Brute Force Greaseable	UJ235
	Brute Force Non Greaseable	UJ269		Brute Force Non Greaseable	UJ234
	(For Aluminum Drive Shaft)	UJ369C		Clamp Kit (Rear)	UJ530-10
	U-Joint (Rear)Ⓢ	UJ372	1984-1982 Firebird w/ Inner Lock Rings: [Type 1]		
	(For Aluminum Drive Shaft)	UJ372C		U-Joint (Front)Ⓢ	UJ534G
	Clamp Kit (Rear)	UJ530-10		Brute Force Greaseable	UJ235
				Brute Force Non Greaseable	UJ234
				Clamp Kit (Front)	UJ530-10
				U-Joint (Rear)Ⓢ	UJ534G
				Brute Force Greaseable	UJ235
				Brute Force Non Greaseable	UJ234
				Clamp Kit (Rear)	UJ530-10

(Continued)



Passenger cars, light & medium trucks

Pontiac (RWD) Firebird, Grand Am (1973-1980), GTO, Le Mans (thru 1981), Tempest (1963-1970) -- (Cont.)

MFG./YEAR	MODEL & LOCATION	PART NO.	MFG./YEAR	MODEL & LOCATION	PART NO.
Drive Shaft (Cont.)			Drive Shaft (Cont.)		
U-Joint (Cont.)			U-Joint (Cont.)		
1984-1982 Firebird w/ Outer Lock Rings: [Type 1]			1975-1969 Firebird: [Type 1]		
	U-Joint (Front) 	UJ331		U-Joint (Front) 	UJ369
	Brute Force Greaseable	UJ232		Brute Force Greaseable	UJ280
	Brute Force Non Greaseable	UJ231		Brute Force Non Greaseable	UJ269
	(For Aluminum Drive Shaft)	UJ331C		(For Aluminum Drive Shaft)	UJ369C
	U-Joint (Rear) 	UJ331		U-Joint (Rear) 	UJ369
	Brute Force Greaseable	UJ232		Brute Force Greaseable	UJ280
	Brute Force Non Greaseable	UJ231		Brute Force Non Greaseable	UJ269
	(For Aluminum Drive Shaft)	UJ331C		(For Aluminum Drive Shaft)	UJ369C
1981-1976 Firebird: [Type 1]			1973-1966 GTO: [Type 1]		
	U-Joint (Front) 	UJ534G		U-Joint (Front) 	UJ534G
	Brute Force Greaseable	UJ235		Brute Force Greaseable	UJ235
	Brute Force Non Greaseable	UJ234		Brute Force Non Greaseable	UJ234
	Clamp Kit (Front)	UJ530-10		U-Joint (Rear) 	UJ534G
	U-Joint (Rear) 	UJ534G		Brute Force Greaseable	UJ235
	Brute Force Greaseable	UJ235		Brute Force Non Greaseable	UJ234
	Brute Force Non Greaseable	UJ234		1972-1964 Lemans & Tempest: [Type 1]	
	Clamp Kit (Rear)	UJ530-10		U-Joint (Front) 	UJ534G
	1981-1973 Lemans: [Type 1]			Brute Force Greaseable	UJ235
	U-Joint (Front) 	UJ534G		Brute Force Non Greaseable	UJ234
	Brute Force Greaseable	UJ235		U-Joint (Rear) 	UJ534G
	Brute Force Non Greaseable	UJ234		Brute Force Greaseable	UJ235
	Clamp Kit (Front)	UJ530-10		Brute Force Non Greaseable	UJ234
	U-Joint (Rear) 	UJ534G		1968-1967 Firebird w/ Turbo Hydramatic Trans.: [Type 1]	
	Brute Force Greaseable	UJ235		U-Joint (Front) 	UJ534G
	Brute Force Non Greaseable	UJ234		Brute Force Greaseable	UJ235
	Clamp Kit (Rear)	UJ530-10		Brute Force Non Greaseable	UJ234
	1980-1978 Grand Am: [Type 1]			U-Joint (Rear) 	UJ355
	U-Joint (Front) 	UJ534G		Brute Force Greaseable	UJ290
	Brute Force Greaseable	UJ235		(For Aluminum Drive Shaft)	UJ355C
	Brute Force Non Greaseable	UJ234		1968-1967 Firebird w/o Turbo Hydramatic Trans.: [Type 1]	
	Clamp Kit (Front)	UJ530-10		U-Joint (Front) 	UJ369
	U-Joint (Rear) 	UJ534G		Brute Force Greaseable	UJ280
	Brute Force Greaseable	UJ235		Brute Force Non Greaseable	UJ269
	Brute Force Non Greaseable	UJ234		(For Aluminum Drive Shaft)	UJ369C
	Clamp Kit (Rear)	UJ530-10		U-Bolt Kit (Front)	UJ329-10
	1975-1973 Grand Am: [Type 1]			U-Joint (Rear) 	UJ369
	U-Joint (Front) 	UJ534G		Brute Force Greaseable	UJ280
	Brute Force Greaseable	UJ235		Brute Force Non Greaseable	UJ269
	Brute Force Non Greaseable	UJ234		(For Aluminum Drive Shaft)	UJ369C
	U-Joint (Rear) 	UJ534G		U-Bolt Kit (Rear)	UJ329-10
	Brute Force Greaseable	UJ235			
	Brute Force Non Greaseable	UJ234			

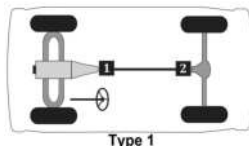

Passenger cars, light & medium trucks

Pontiac (RWD) G8

MFG./YEAR	MODEL & LOCATION	PART NO.	MFG./YEAR	MODEL & LOCATION	PART NO.
-----------	------------------	----------	-----------	------------------	----------

Drive Shaft

U-Joint

2009-2008 All:

Flex CouplerVKJF98022

Pontiac (RWD) T1000

Drive Shaft

U-Joint

1987-1981 All: [Type 1]

U-Joint (Front)ⓈUJ368

Clamp Kit (Front)UJ360-10

U-Joint (Rear)ⓈUJ368

Clamp Kit (Rear)UJ360-10

Porsche CUV Cayenne, Macon

Drive Shaft

U-Joint

2014-2008 Cayenne:

Flex CouplerVKJF98038

2006-2003 Cayenne:

Flex CouplerVKJF98041

Rolls Royce Camargue, Corniche, Phantom, Silver Cloud, Silver Shadow, Silver Wraith II

Drive Shaft

U-Joint

1977-1963 All: [Type 1]

U-Joint (Front)ⓈUJ331

Brute Force GreaseableUJ232

Brute Force Non GreaseableUJ231

(For Aluminum Drive Shaft)UJ331C

U-Joint (Rear)ⓈUJ331

Brute Force GreaseableUJ232

Brute Force Non GreaseableUJ231

(For Aluminum Drive Shaft)UJ331C

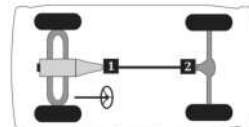

Passenger cars, light & medium trucks

SRT Viper

MFG./YEAR	MODEL & LOCATION	PART NO.	MFG./YEAR	MODEL & LOCATION	PART NO.
Drive Shaft					
U-Joint					
2014-2013 All: [Type 1]					
	U-Joint (Front)Ⓛ	UJ331			
	Brute Force Greaseable	UJ232			
	Brute Force Non Greaseable	UJ231			
	(For Aluminum Drive Shaft)	UJ331C			
	U-Joint (Rear)Ⓞ	UJ331			
	Brute Force Greaseable	UJ232			
	Brute Force Non Greaseable	UJ231			
	(For Aluminum Drive Shaft)	UJ331C			

Studebaker Passenger Cars

MFG./YEAR	MODEL & LOCATION	PART NO.	MFG./YEAR	MODEL & LOCATION	PART NO.
Drive Shaft					
U-Joint					
1966-1964 w/ Inner Lock Rings: [Type 1]					
	U-Joint (Front)Ⓛ	UJ507			
	U-Joint (Rear)Ⓞ	UJ505			
1966-1964 w/ Outer Lock Rings: [Type 1]					
	U-Joint (Front)Ⓛ	UJ369			
	Brute Force Greaseable	UJ280			
	Brute Force Non Greaseable	UJ269			
	(For Aluminum Drive Shaft)	UJ369C			
	U-Joint (Rear)Ⓞ	UJ369			
	Brute Force Greaseable	UJ280			
	Brute Force Non Greaseable	UJ269			
	(For Aluminum Drive Shaft)	UJ369C			
1963 Passenger Vehicles: [Type 1]					
	U-Joint (Front)Ⓛ	UJ507			
	U-Joint (Rear)Ⓞ	UJ505			
Drive Shaft (Cont.)					
U-Joint (Cont.)					
1962-1950 Passenger Vehicles: [Type 1]					
	U-Joint (Front)Ⓛ	UJ369			
	Brute Force Greaseable	UJ280			
	Brute Force Non Greaseable	UJ269			
	(For Aluminum Drive Shaft)	UJ369C			
	U-Joint (Rear)Ⓞ	UJ369			
	Brute Force Greaseable	UJ280			
	Brute Force Non Greaseable	UJ269			
	(For Aluminum Drive Shaft)	UJ369C			

Subaru

MFG./YEAR	MODEL & LOCATION	PART NO.	MFG./YEAR	MODEL & LOCATION	PART NO.
Drive Shaft					
U-Joint					
1999 Legacy: [Type 41]					
	U-Joint (Front)Ⓛ	[2] UJ437G			
	Brute Force Greaseable	UJ240			
	Brute Force Non Greaseable	UJ237			
	U-Joint (Rear)Ⓞ	UJ437G			
	Brute Force Greaseable	UJ240			
	Brute Force Non Greaseable	UJ237			
1987-1978 Brat: [Type 7]					
	U-Joint (Rear)Ⓛ	UJ391			
Drive Shaft (4 W/D)					
U-Joint					
1990-1985 XT: [Type 17]					
	U-Joint (Rr. Shaft; Frt.)Ⓛ	UJ10430			
	U-Joint (Rr. Shaft; Rr.)Ⓞ	UJ10430			
1989-1985 DL, GL, GL-10 & RX: [Type 17]					
	U-Joint (Rr. Shaft; Frt.)Ⓛ	UJ10430			
	U-Joint (Rr. Shaft; Rr.)Ⓞ	UJ10430			
Drive Shaft (AWD)					
U-Joint					
1999-1990 Legacy: [Type 41]					
	U-Joint (Front)Ⓛ	UJ10430			
	U-Joint (Rear)Ⓞ	UJ10430			
1997-1992 SVX: [Type 41]					
	U-Joint (Front)Ⓛ	UJ10430			
	U-Joint (Rear)Ⓞ	UJ10430			

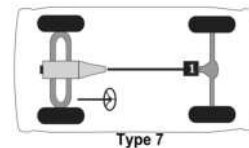
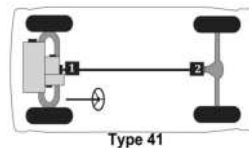
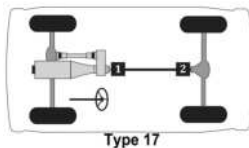
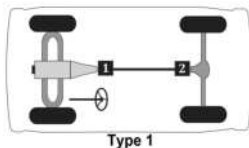

Passenger cars, light & medium trucks

Sunbeam

MFG./YEAR	MODEL & LOCATION	PART NO.	MFG./YEAR	MODEL & LOCATION	PART NO.
Drive Shaft					
U-Joint					
1971-1957 Alpine & Rapier: [Type 1]					
	U-Joint (Front)❶	UJ341			
	U-Joint (Rear)❷	UJ341			
1967-1964 Tiger 260 & 289: [Type 1]					
	U-Joint (Front)❶	UJ344			
	U-Joint (Rear)❷	UJ344			

Suzuki

Drive Shaft (2 W/D)		
U-Joint		
2013-2006 Grand Vitara: [Type 1]		
	U-Joint (Front)❶	UJ408
	U-Joint (Rear)❷	UJ408
2011-2009 Equator w/ 4 Cyl Eng.: [Type 2]		
	U-Joint (Front)❶	UJ369
	<i>Brute Force Greaseable</i>	UJ280
	<i>Brute Force Non Greaseable</i>	UJ269
	(For Aluminum Drive Shaft)	UJ369C
	U-Joint (Center)❸	UJ369
	<i>Brute Force Greaseable</i>	UJ280
	<i>Brute Force Non Greaseable</i>	UJ269
	(For Aluminum Drive Shaft)	UJ369C
	U-Joint (Rear)❹	UJ369
	<i>Brute Force Greaseable</i>	UJ280
	<i>Brute Force Non Greaseable</i>	UJ269
	(For Aluminum Drive Shaft)	UJ369C
2011-2009 Equator w/ 6 Cyl. Eng.: [Type 2]		
	U-Joint (Front)❶	UJ354
	<i>Brute Force Greaseable</i>	UJ270
	<i>Brute Force Non Greaseable</i>	UJ254
	(For Aluminum Drive Shaft)	UJ354C
	U-Joint (Center)❸	UJ354
	<i>Brute Force Greaseable</i>	UJ270
	<i>Brute Force Non Greaseable</i>	UJ254
	(For Aluminum Drive Shaft)	UJ354C
	U-Joint (Rear)❹	UJ354
	<i>Brute Force Greaseable</i>	UJ270
	<i>Brute Force Non Greaseable</i>	UJ254
	(For Aluminum Drive Shaft)	UJ354C
2006-2002 XL-7: [Type 4]		
	U-Joint (Front)❶	UJ408
2005-1999 Grand Vitara w/ Auto. Trans.: [Type 1]		
	U-Joint (Front)❶	UJ398
	U-Joint (Rear)❷	UJ398
2005-1999 Grand Vitara w/ Man. Trans.: [Type 1]		
	U-Joint (Front)❶	UJ408
	U-Joint (Rear)❷	UJ408
2004-1999 Vitara: [Type 1]		
	U-Joint (Front)❶	UJ398
	U-Joint (Rear)❷	UJ398

Drive Shaft (2 W/D) (Cont.)		
U-Joint (Cont.)		
1998-1991 Sidekick: [Type 1]		
	U-Joint (Front)❶	UJ398
	U-Joint (Rear)❷	UJ398
Drive Shaft (4 W/D)		
U-Joint		
2013-2006 Grand Vitara: [Type 17]		
	U-Joint (Rr. Shaft; Frt.)❶	UJ408
	U-Joint (Rr. Shaft; Rr.)❷	UJ408
2011-2009 Equator: [Type 13]		
	U-Joint (Frt. Shaft; Frt.)❶	UJ369
	<i>Brute Force Greaseable</i>	UJ280
	<i>Brute Force Non Greaseable</i>	UJ269
	(For Aluminum Drive Shaft)	UJ369C
	U-Joint (Frt. Shaft; Rr.)❷	UJ369
	<i>Brute Force Greaseable</i>	UJ280
	<i>Brute Force Non Greaseable</i>	UJ269
	(For Aluminum Drive Shaft)	UJ369C
	U-Joint (Rr. Shaft; Frt.)❸	UJ354
	<i>Brute Force Greaseable</i>	UJ270
	<i>Brute Force Non Greaseable</i>	UJ254
	(For Aluminum Drive Shaft)	UJ354C
	U-Joint (Rr. Shaft; Rr.)❹	UJ354
	<i>Brute Force Greaseable</i>	UJ270
	<i>Brute Force Non Greaseable</i>	UJ254
	(For Aluminum Drive Shaft)	UJ354C
2006-2001 XL-7: [Type 19]		
	U-Joint (Frt. Shaft; Frt.)❶	UJ398
	U-Joint (Frt. Shaft; Rr.)❷	UJ398
	U-Joint (Rr. Shaft; Frt.)❸	UJ408
2005-1999 Grand Vitara & Vitara w/ Auto. Trans.: [Type 13]		
	U-Joint (Frt. Shaft; Frt.)❶	UJ398
	U-Joint (Frt. Shaft; Rr.)❷	UJ398
	U-Joint (Rr. Shaft; Frt.)❸	UJ398
	U-Joint (Rr. Shaft; Rr.)❹	UJ398
2005-1999 Grand Vitara & Vitara w/ Man. Trans.: [Type 13]		
	U-Joint (Frt. Shaft; Frt.)❶	UJ398
	U-Joint (Frt. Shaft; Rr.)❷	UJ398
	U-Joint (Rr. Shaft; Frt.)❸	UJ408
	U-Joint (Rr. Shaft; Rr.)❹	UJ408

(Continued)

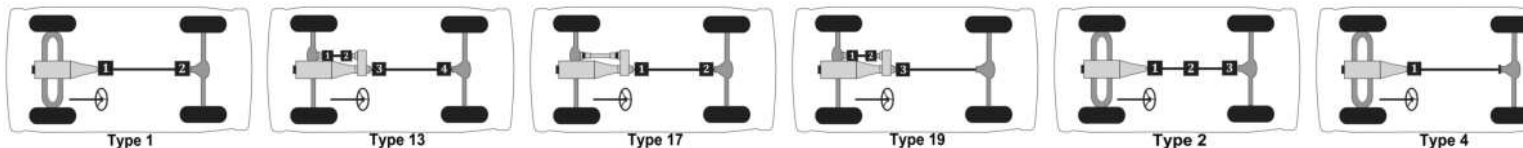

Passenger cars, light & medium trucks

Suzuki -- (Cont.)

MFG./YEAR	MODEL & LOCATION	PART NO.	MFG./YEAR	MODEL & LOCATION	PART NO.
Drive Shaft (4 W/D) (Cont.)			Drive Shaft (4 W/D) (Cont.)		
U-Joint (Cont.)			U-Joint (Cont.)		
2004-1999 Vitara: [Type 13]			1995-1986 Samurai: [Type 25]		
	U-Joint (Fr. Shaft; Frt.) ^①	UJ398		U-Joint (Fr. Shaft; Frt.) ^①	UJ398
	U-Joint (Fr. Shaft; Rr.) ^②	UJ398		U-Joint (Fr. Shaft; Rr.) ^②	UJ398
	U-Joint (Rr. Shaft; Frt.) ^③	UJ398		U-Joint (Intmd. Shaft; Frt.) ^④	UJ398
	U-Joint (Rr. Shaft; Rr.) ^④	UJ398		U-Joint (Intmd. Shaft; Rr.) ^④	UJ398
1998-1989 Sidekick: [Type 13]			U-Joint (Rr. Shaft; Frt.) ^⑤		
	U-Joint (Fr. Shaft; Frt.) ^①	UJ398	U-Joint (Rr. Shaft; Rr.) ^⑥		
	U-Joint (Fr. Shaft; Rr.) ^②	UJ398			
	U-Joint (Rr. Shaft; Frt.) ^③	UJ398			
	U-Joint (Rr. Shaft; Rr.) ^④	UJ398			

Toyota (RWD), 86

MFG./YEAR	MODEL & LOCATION	PART NO.	MFG./YEAR	MODEL & LOCATION	PART NO.
Drive Shaft			Drive Shaft (Cont.)		
U-Joint			U-Joint (Cont.)		
1993-1985 Supra: [Type 2]			1979-1971 Corolla w/ 1.6L Eng.: [Type 1]		
	U-Joint (Front) ^①	UJ387		U-Joint (Front) ^①	UJ394
	<i>Brute Force Greaseable</i>	UJ285		U-Joint (Rear) ^②	UJ394
	<i>Brute Force Non Greaseable</i>	UJ287	1979-1968 Corolla w/ 1.1L & 1.2L Eng.s.: [Type 1]		
	U-Joint (Center) ^②	UJ387		U-Joint (Front) ^①	UJ395
	<i>Brute Force Greaseable</i>	UJ285		U-Joint (Rear) ^②	UJ395
	<i>Brute Force Non Greaseable</i>	UJ287	1979-1965 Corona & Mark II w/ 2 Joint Shaft:		
	U-Joint (Rear) ^③	UJ387	[Type 1]		
	<i>Brute Force Greaseable</i>	UJ285		U-Joint (Front) ^①	UJ394
	<i>Brute Force Non Greaseable</i>	UJ287		U-Joint (Rear) ^②	UJ394
1984-1981 Cressida Wagon: [Type 1]			1979-1965 Corona & Mark II w/ 3 Joint Shaft:		
	U-Joint (Front) ^①	UJ394	[Type 2]		
	U-Joint (Rear) ^②	UJ394		U-Joint (Front) ^①	UJ394
1984-1980 Starlet: [Type 1]				U-Joint (Center) ^②	UJ394
	U-Joint (Front) ^①	UJ395		U-Joint (Rear) ^③	UJ394
	U-Joint (Rear) ^②	UJ395	1973-1972 Carina: [Type 1]		
1983-1980 Corolla Sedan: [Type 2]				U-Joint (Front) ^①	UJ394
	U-Joint (Front) ^①	UJ394		U-Joint (Rear) ^②	UJ394
	U-Joint (Center) ^②	UJ394	1972-1971 Crown From 2/71: [Type 2]		
	U-Joint (Rear) ^③	UJ394		U-Joint (Front) ^①	UJ387
1982-1980 Corona: [Type 1]				<i>Brute Force Greaseable</i>	UJ285
	U-Joint (Front) ^①	UJ394		<i>Brute Force Non Greaseable</i>	UJ287
	U-Joint (Rear) ^②	UJ394		U-Joint (Center) ^②	UJ387
1981-1971 Celica w/ 2 Joint Shaft: [Type 1]				<i>Brute Force Greaseable</i>	UJ285
	U-Joint (Front) ^①	UJ394		<i>Brute Force Non Greaseable</i>	UJ287
	U-Joint (Rear) ^②	UJ394		U-Joint (Rear) ^③	UJ387
1981-1971 Celica w/ 3 Joint Shaft: [Type 2]				<i>Brute Force Greaseable</i>	UJ285
	U-Joint (Front) ^①	UJ394		<i>Brute Force Non Greaseable</i>	UJ287
	U-Joint (Center) ^②	UJ394	1971-1967 Crown From 9/66 Thru 1/71: [Type 1]		
	U-Joint (Rear) ^③	UJ394		U-Joint (Front) ^①	UJ387
1980-1978 Cressida Sedan: [Type 2]				<i>Brute Force Greaseable</i>	UJ285
	U-Joint (Front) ^①	UJ394		<i>Brute Force Non Greaseable</i>	UJ287
	U-Joint (Center) ^②	UJ394		U-Joint (Rear) ^②	UJ387
	U-Joint (Rear) ^③	UJ394		<i>Brute Force Greaseable</i>	UJ285
1980-1978 Cressida Wagon: [Type 1]				<i>Brute Force Non Greaseable</i>	UJ287
	U-Joint (Front) ^①	UJ394			
	U-Joint (Rear) ^②	UJ394			

(Continued)

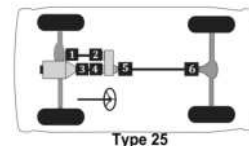
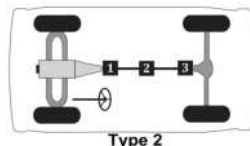
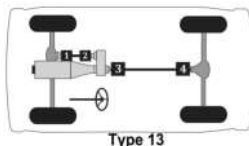
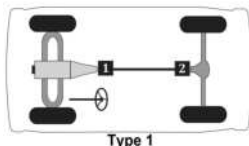

Passenger cars, light & medium trucks

(Cont.) -- Toyota (RWD), 86

MFG./YEAR	MODEL & LOCATION	PART NO.	MFG./YEAR	MODEL & LOCATION	PART NO.
Drive Shaft (Cont.)					
U-Joint (Cont.)					
1967-1964 Crown Thru 8/66: [Type 1]					
	U-Joint (Front)ⓉUJ394			
	U-Joint (Rear)ⓉUJ394			

Toyota Previa, Sienna

Drive Shaft (AWD)		
U-Joint		
2010-2004 Sienna: [Type 41]		
	U-Joint (Front)ⓉUJ10430
	U-Joint (Rear)ⓉUJ10430
1996-1991 Previa: [N/A]		
	U-Joint (Front)UJ10430
	U-Joint (Rear)UJ10430

Triumph

Drive Shaft		
U-Joint		
1981-1975 TR7 & TR8: [Type 1]		
	U-Joint (Front)ⓉUJ341
	U-Joint (Rear)ⓉUJ341
1980-1963 GT6 & Spitfire: [Type 8]		
	U-Joint (Front)ⓉUJ341
	U-Joint (Rear)ⓉUJ341
	U-Joint (Rear Half Shaft)Ⓣ[2] UJ341
1977-1965 TR4A, TR5, TR6 & TR250: [Type 8]		
	U-Joint (Front)ⓉUJ344
	U-Joint (Rear)ⓉUJ344
	U-Joint (Rear Half Shaft)Ⓣ[2] UJ344
1973-1970 Stag: [Type 8]		
	U-Joint (Front)ⓉUJ344
	U-Joint (Rear)ⓉUJ344
	U-Joint (Rear Half Shaft)Ⓣ[2] UJ344

Drive Shaft (Cont.)		
U-Joint (Cont.)		
1965-1953 TR2, TR3 & TR4: [Type 1]		
	U-Joint (Front)ⓉUJ344
	U-Joint (Rear)ⓉUJ344

Volkswagen Arteon, Golf

Drive Shaft		
U-Joint		
2021-2019 Arteon:		
	Flex CouplerVKJF98040
2019-2017 Golf:		
	Flex CouplerVKJF98040
2010-2000 Sharan:		
	Flex CouplerVKJF98039

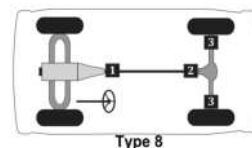
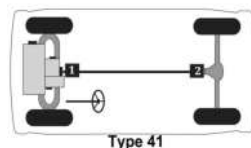
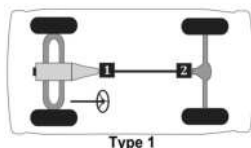

Passenger cars, light & medium trucks

Volvo S60, S90, V60, V90, 140 series, 164, 240 series, 260 series, 740 series, 760 series, 780 series, 940 series, 960 series

MFG./YEAR	MODEL & LOCATION	PART NO.	MFG./YEAR	MODEL & LOCATION	PART NO.
Drive Shaft			Drive Shaft (Cont.)		
U-Joint			U-Joint (Cont.)		
1994-1991 940 & 960: [Type 2]			1984-1983 760 w/ 1.063" Brg. Cap: [Type 2]		
	U-Joint (Front)❶	UJ344		U-Joint (Front)❶	UJ344
	U-Joint (Center)Ⓣ	UJ344		U-Joint (Center)Ⓣ	UJ344
	U-Joint (Rear)Ⓣ	UJ344		U-Joint (Rear)Ⓣ	UJ344
1993-1985 240 Series: [Type 2]			1984-1975 240 & 260 Series w/ 1.75" Dia.		
	U-Joint (Front)❶	UJ344	Driveshaft: [Type 2]		
	U-Joint (Center)Ⓣ	UJ344		U-Joint (Front)❶	UJ341
	U-Joint (Rear)Ⓣ	UJ344		U-Joint (Center)Ⓣ	UJ341
1992-1988 740, 760 & 780 w/ 3.25" Yoke: [Type 2]				U-Joint (Rear)Ⓣ	UJ344
	U-Joint (Front)❶	UJ344	1984-1975 240 & 260 Series w/ 2" Dia. Driveshaft:		
	U-Joint (Center)Ⓣ	UJ344	[Type 2]		
	U-Joint (Rear)Ⓣ	UJ344		U-Joint (Front)❶	UJ369
1992-1988 740, 760 & 780 w/ 3.5" Yoke: [Type 2]				<i>Brute Force Greaseable</i>	UJ280
	U-Joint (Front)❶	UJ369		<i>Brute Force Non Greaseable</i>	UJ269
	<i>Brute Force Greaseable</i>	UJ280		(For Aluminum Drive Shaft)	UJ369C
	<i>Brute Force Non Greaseable</i>	UJ269		U-Joint (Center)Ⓣ	UJ369
	(For Aluminum Drive Shaft)	UJ369C		<i>Brute Force Greaseable</i>	UJ280
	U-Joint (Center)Ⓣ	UJ369		<i>Brute Force Non Greaseable</i>	UJ269
	<i>Brute Force Greaseable</i>	UJ280		(For Aluminum Drive Shaft)	UJ369C
	<i>Brute Force Non Greaseable</i>	UJ269		U-Joint (Rear)Ⓣ	UJ369
	(For Aluminum Drive Shaft)	UJ369C		<i>Brute Force Greaseable</i>	UJ280
	U-Joint (Rear)Ⓣ	UJ369		<i>Brute Force Non Greaseable</i>	UJ269
	<i>Brute Force Greaseable</i>	UJ280		(For Aluminum Drive Shaft)	UJ369C
	<i>Brute Force Non Greaseable</i>	UJ269	1975-1969 164: [Type 2]		
	(For Aluminum Drive Shaft)	UJ369C		U-Joint (Front)❶	UJ369
1987-1985 740, 760 & 780 w/ 1.75" Dia.				<i>Brute Force Greaseable</i>	UJ280
Driveshaft: [Type 2]				<i>Brute Force Non Greaseable</i>	UJ269
	U-Joint (Front)❶	UJ341		(For Aluminum Drive Shaft)	UJ369C
	U-Joint (Center)Ⓣ	UJ341		U-Joint (Center)Ⓣ	UJ369
	U-Joint (Rear)Ⓣ	UJ344		<i>Brute Force Greaseable</i>	UJ280
1987-1985 740, 760 & 780 w/ 2" Dia. Driveshaft & 3.25" Yoke: [Type 2]				<i>Brute Force Non Greaseable</i>	UJ269
	U-Joint (Front)❶	UJ344		(For Aluminum Drive Shaft)	UJ369C
	U-Joint (Center)Ⓣ	UJ344		U-Joint (Rear)Ⓣ	UJ369
	U-Joint (Rear)Ⓣ	UJ344		<i>Brute Force Greaseable</i>	UJ280
1987-1985 740, 760 & 780 w/ 2" Dia. Driveshaft & 3.5" Yoke: [Type 2]				<i>Brute Force Non Greaseable</i>	UJ269
	U-Joint (Front)❶	UJ369		(For Aluminum Drive Shaft)	UJ369C
	<i>Brute Force Greaseable</i>	UJ280		U-Joint (Front)❶	UJ341
	<i>Brute Force Non Greaseable</i>	UJ269		U-Joint (Center)Ⓣ	UJ341
	(For Aluminum Drive Shaft)	UJ369C		U-Joint (Rear)Ⓣ	UJ344
	U-Joint (Center)Ⓣ	UJ369	(Continued)		
	<i>Brute Force Greaseable</i>	UJ280			
	<i>Brute Force Non Greaseable</i>	UJ269			
	(For Aluminum Drive Shaft)	UJ369C			
	U-Joint (Rear)Ⓣ	UJ369			
	<i>Brute Force Greaseable</i>	UJ280			
	<i>Brute Force Non Greaseable</i>	UJ269			
	(For Aluminum Drive Shaft)	UJ369C			
1984-1983 760 w/ 0.938" Brg. Cap: [Type 2]					
	U-Joint (Front)❶	UJ341			
	U-Joint (Center)Ⓣ	UJ341			
	U-Joint (Rear)Ⓣ	UJ344			

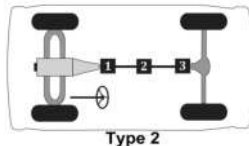

76 ▲ For Use w/ 1.063" Bearing Cap Application. Ⓣ For Use w/ 1.188" Bearing Cap Application. ◇ For Use w/ Inner Lock Ring Application on Half Shaft. □ For Use w/ Outer Lock Ring Application on Half Shaft.

Passenger cars, light & medium trucks

(Cont.) -- Volvo S60, S90, V60, V90, 140 series, 164, 240 series, 260 series, 740 series, 760 series, 780 series, 940 series, 960 series

MFG./YEAR	MODEL & LOCATION	PART NO.	MFG./YEAR	MODEL & LOCATION	PART NO.
Drive Shaft (Cont.)			Drive Shaft (Cont.)		
U-Joint (Cont.)			U-Joint (Cont.)		
1974	140 Series w/ Fuel Inj. Eng.: [Type 2]		1973-1961 1800:	[Type 2]	
	U-Joint (Front)Ⓢ	UJ369		U-Joint (Front)Ⓢ	UJ341
	Brute Force Greaseable	UJ280		U-Joint (Center)Ⓢ	UJ341
	Brute Force Non Greaseable	UJ269		U-Joint (Rear)Ⓢ	UJ341
	(For Aluminum Drive Shaft)	UJ369C	1972-1971 140 Series w/ Carb. Eng.: [Type 2]		
	U-Joint (Center)Ⓢ	UJ369		U-Joint (Front)Ⓢ	UJ341
	Brute Force Greaseable	UJ280		U-Joint (Center)Ⓢ	UJ341
	Brute Force Non Greaseable	UJ269		U-Joint (Rear)Ⓢ	UJ341
	(For Aluminum Drive Shaft)	UJ369C	1972-1967 140 Series w/ Fuel Inj. Eng.: [Type 2]		
	U-Joint (Rear)Ⓢ	UJ369		U-Joint (Front)Ⓢ	UJ369
	Brute Force Greaseable	UJ280		Brute Force Greaseable	UJ280
	Brute Force Non Greaseable	UJ269		Brute Force Non Greaseable	UJ269
	(For Aluminum Drive Shaft)	UJ369C		(For Aluminum Drive Shaft)	UJ369C
1973	140 Series w/ Carb. Eng.: [Type 2]			U-Joint (Center)Ⓢ	UJ369
	U-Joint (Front)Ⓢ	UJ341		Brute Force Greaseable	UJ280
	U-Joint (Center)Ⓢ	UJ341		Brute Force Non Greaseable	UJ269
	U-Joint (Rear)Ⓢ	UJ341		(For Aluminum Drive Shaft)	UJ369C
1973	140 Series w/ Fuel Inj. Eng. & Auto. Trans.: [Type 2]			U-Joint (Rear)Ⓢ	UJ369
	U-Joint (Front)Ⓢ	UJ369		Brute Force Greaseable	UJ280
	Brute Force Greaseable	UJ280		Brute Force Non Greaseable	UJ269
	Brute Force Non Greaseable	UJ269		(For Aluminum Drive Shaft)	UJ369C
	(For Aluminum Drive Shaft)	UJ369C		1968-1960 122: [Type 2]	
	U-Joint (Center)Ⓢ	UJ369		U-Joint (Front)Ⓢ	UJ341
	Brute Force Greaseable	UJ280		U-Joint (Center)Ⓢ	UJ341
	Brute Force Non Greaseable	UJ269		U-Joint (Rear)Ⓢ	UJ341
	(For Aluminum Drive Shaft)	UJ369C			
	U-Joint (Rear)Ⓢ	UJ369			
	Brute Force Greaseable	UJ280			
	Brute Force Non Greaseable	UJ269			
	(For Aluminum Drive Shaft)	UJ369C			
1973	140 Series w/ Fuel Inj. Eng. & Man. Trans.: [Type 2]				
	U-Joint (Front)Ⓢ	UJ341			
	U-Joint (Center)Ⓢ	UJ369			
	Brute Force Greaseable	UJ280			
	Brute Force Non Greaseable	UJ269			
	(For Aluminum Drive Shaft)	UJ369C			
	U-Joint (Rear)Ⓢ	UJ369			
	Brute Force Greaseable	UJ280			
	Brute Force Non Greaseable	UJ269			
	(For Aluminum Drive Shaft)	UJ369C			

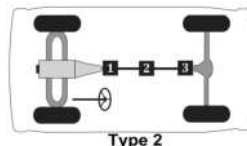

**Light and Medium Duty Trucks
(2 WD & 4 WD) and Vans**

Passenger cars, light & medium trucks

Acura Truck SLX

MFG./YEAR	MODEL & LOCATION	PART NO.	MFG./YEAR	MODEL & LOCATION	PART NO.
Drive Shaft (4 W/D)					
U-Joint					
1999-1998 All: [Type 13]					
	U-Joint (Frnt. Shaft; Frt.) ^①	UJ383			
	U-Joint (Frnt. Shaft; Rr.) ^②	UJ383			
	U-Joint (Rr. Shaft; Frt.) ^③	UJ411			
	U-Joint (Rr. Shaft; Rr.) ^④	UJ411			
1997-1996 All: [Type 14]					
	U-Joint (Frnt. Shaft; Frt.) ^①	UJ383			
	U-Joint (Frnt. Shaft; Rr.) ^②	UJ383			
	U-Joint (Rr. Shaft; Frt.) ^③	UJ383			
	U-Joint (Rr. Shaft; Ctr.) ^④	UJ383			
	U-Joint (Rr. Shaft; Rr.) ^⑤	UJ383			

Buick Truck Rainier

Drive Shaft (2 W/D)			Drive Shaft (AWD)		
U-Joint			U-Joint		
2007-2004 All: [Type 1]			2007-2004 All: [Type 15]		
	U-Joint (Front) ^①	UJ534G		U-Joint (Frnt. Shaft; Frt.) ^①	UJ445
	Brute Force Greaseable	UJ235		Brute Force Greaseable	UJ225
	Brute Force Non Greaseable	UJ234		Clamp Kit (Frnt. Shaft; Frt.)	UJ360-10
	U-Joint (Rear) ^②	UJ534G		U-Joint (Rr. Shaft; Frt.) ^②	UJ534G
	Brute Force Greaseable	UJ235		Brute Force Greaseable	UJ235
	Brute Force Non Greaseable	UJ234		Brute Force Non Greaseable	UJ234
				Clamp Kit (Rr. Shaft; Frt.)	UJ530-10
				U-Joint (Rr. Shaft; Rr.) ^③	UJ534G
				Brute Force Greaseable	UJ235
				Brute Force Non Greaseable	UJ234
				Clamp Kit (Rr. Shaft; Rr.)	UJ530-10

Cadillac Truck US & Canada, Escalade

Drive Shaft (2 W/D)			Drive Shaft (2 W/D) (Cont.)		
U-Joint			U-Joint (Cont.)		
2020-2015 Escalade: [Type 1]			2005 Escalade w/ 5.3L Eng.: [Type 1]		
	U-Joint (Front) ^①	UJ330		U-Joint (Front) ^①	UJ534G
	Brute Force Greaseable	UJ295		Brute Force Greaseable	UJ235
	(For Aluminum Drive Shaft)	UJ330C		Brute Force Non Greaseable	UJ234
	U-Joint (Rear) ^②	UJ330		Clamp Kit (Front)	UJ530-10
	Brute Force Greaseable	UJ295		U-Joint (Rear) ^②	UJ534G
	(For Aluminum Drive Shaft)	UJ330C		Brute Force Greaseable	UJ235
	2014-2006 Escalade: [Type 1]			Brute Force Non Greaseable	UJ234
	U-Joint (Front) ^①	UJ331A		Clamp Kit (Rear)	UJ530-10
	Brute Force Greaseable	UJ232A		2005 Escalade w/ 6.0L Eng.: [Type 1]	
	Clamp Kit (Front)	UJ492-10		U-Joint (Front) ^①	UJ331A
	U-Joint (Rear) ^②	UJ331A		Brute Force Greaseable	UJ232A
	Brute Force Greaseable	UJ232A		Clamp Kit (Front)	UJ492-10
	Clamp Kit (Rear)	UJ492-10		U-Joint (Rear) ^②	UJ331A
				Brute Force Greaseable	UJ232A
				Clamp Kit (Rear)	UJ492-10
					(Continued)

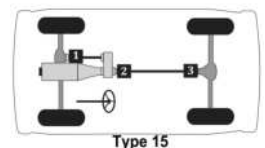
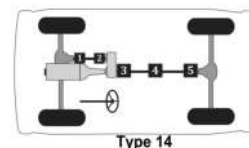
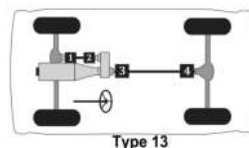
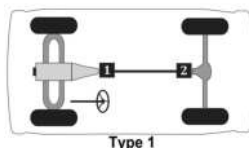

Passenger cars, light & medium trucks

Cadillac Truck US & Canada, Escalade -- (Cont.)

MFG./YEAR	MODEL & LOCATION	PART NO.	MFG./YEAR	MODEL & LOCATION	PART NO.
Drive Shaft (2 W/D) (Cont.)			Drive Shaft (4 W/D) (Cont.)		
U-Joint (Cont.)			U-Joint (Cont.)		
2004-2003 Escalade: [Type 1]			2000-1999 All: [Type 13]		
	U-Joint (Front)Ⓚ	UJ534G		U-Joint (Frnt. Shaft; Frt.)Ⓚ	UJ534G
	Brute Force Greaseable	UJ235		Brute Force Greaseable	UJ235
	Brute Force Non Greaseable	UJ234		Brute Force Non Greaseable	UJ234
	Clamp Kit (Front)	UJ530-10		Clamp Kit (Frnt. Shaft; Frt.)	UJ530-10
	U-Joint (Rear)Ⓛ	UJ534G		U-Joint (Frnt. Shaft; Rr.)Ⓛ	UJ534G
	Brute Force Greaseable	UJ235		Brute Force Greaseable	UJ235
	Brute Force Non Greaseable	UJ234		Brute Force Non Greaseable	UJ234
	Clamp Kit (Rear)	UJ530-10		Clamp Kit (Frnt. Shaft; Rr.)	UJ530-10
Drive Shaft (4 W/D)			U-Joint (Rr. Shaft; Frt.)Ⓛ		
U-Joint			Brute Force Greaseable		
2018-2015 Escalade: [Type 13]			UJ235		
	U-Joint (Frnt. Shaft; Frt.)Ⓚ	UJ534G		Brute Force Non Greaseable	UJ234
	Brute Force Greaseable	UJ235		Clamp Kit (Rr. Shaft; Frt.)	UJ530-10
	Brute Force Non Greaseable	UJ234		U-Joint (Rr. Shaft; Rr.)Ⓛ	UJ534G
	Clamp Kit (Frnt. Shaft; Frt.)	UJ530-10		Brute Force Greaseable	UJ235
	U-Joint (Frnt. Shaft; Rr.)Ⓛ	UJ534G		Brute Force Non Greaseable	UJ234
	Brute Force Greaseable	UJ235		Clamp Kit (Rr. Shaft; Rr.)	UJ530-10
	Brute Force Non Greaseable	UJ234	Drive Shaft (AWD)		
	Clamp Kit (Frnt. Shaft; Rr.)	UJ530-10	U-Joint		
	U-Joint (Rr. Shaft; Frt.)Ⓛ	UJ330	2014-2009 All: [Type 13]		
	Brute Force Greaseable	UJ295		U-Joint (Frnt. Shaft; Frt.)Ⓚ	UJ534G
	(For Aluminum Drive Shaft)	UJ330C		Brute Force Greaseable	UJ235
	U-Joint (Rr. Shaft; Rr.)Ⓛ	UJ330		Brute Force Non Greaseable	UJ234
	Brute Force Greaseable	UJ295		Clamp Kit (Frnt. Shaft; Frt.)	UJ530-10
	(For Aluminum Drive Shaft)	UJ330C		U-Joint (Frnt. Shaft; Rr.)Ⓛ	UJ534G
	2018-2015 Escalade ESV: [Type 13]			Brute Force Greaseable	UJ235
	U-Joint (Frnt. Shaft; Frt.)Ⓚ	UJ330		Brute Force Non Greaseable	UJ234
	Brute Force Greaseable	UJ295		Clamp Kit (Frnt. Shaft; Rr.)	UJ530-10
	(For Aluminum Drive Shaft)	UJ330C		U-Joint (Rr. Shaft; Frt.)Ⓛ	UJ331A
	U-Joint (Frnt. Shaft; Rr.)Ⓛ	UJ330		Brute Force Greaseable	UJ232A
	Brute Force Greaseable	UJ295		U-Joint (Rr. Shaft; Rr.)Ⓛ	UJ331A
	(For Aluminum Drive Shaft)	UJ330C		Brute Force Greaseable	UJ232A
	U-Joint (Rr. Shaft; Frt.)Ⓛ	UJ330	2008-2007 Escalade: [Type 13]		
	Brute Force Greaseable	UJ295		U-Joint (Frnt. Shaft; Frt.)Ⓚ	UJ534G
	(For Aluminum Drive Shaft)	UJ330C		Brute Force Greaseable	UJ235
	U-Joint (Rr. Shaft; Rr.)Ⓛ	UJ330		Brute Force Non Greaseable	UJ234
	Brute Force Greaseable	UJ295		Clamp Kit (Frnt. Shaft; Frt.)	UJ530-10
	(For Aluminum Drive Shaft)	UJ330C		U-Joint (Frnt. Shaft; Rr.)Ⓛ	UJ534G
				Brute Force Greaseable	UJ235
				Brute Force Non Greaseable	UJ234
				Clamp Kit (Frnt. Shaft; Rr.)	UJ530-10
				U-Joint (Rr. Shaft; Frt.)Ⓛ	UJ534G
				Brute Force Greaseable	UJ235
				Brute Force Non Greaseable	UJ234
				Clamp Kit (Rr. Shaft; Frt.)	UJ530-10
				U-Joint (Rr. Shaft; Rr.)Ⓛ	UJ534G
				Brute Force Greaseable	UJ235
				Brute Force Non Greaseable	UJ234
				Clamp Kit (Rr. Shaft; Rr.)	UJ530-10
					(Continued)

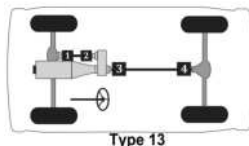
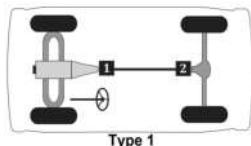

Passenger cars, light & medium trucks

(Cont.) -- Cadillac Truck US & Canada, Escalade

MFG./YEAR	MODEL & LOCATION	PART NO.	MFG./YEAR	MODEL & LOCATION	PART NO.
Drive Shaft (AWD) (Cont.)			Drive Shaft (AWD) (Cont.)		
U-Joint (Cont.)			U-Joint (Cont.)		
2008-2007 Escalade ESV & EXT: [Type 13]			2006-2002 All: [Type 13]		
	U-Joint (Frnt. Shaft; Frt.) ^①	UJ534G		U-Joint (Frnt. Shaft; Frt.) ^①	UJ534G
	Brute Force Greaseable	UJ235		Brute Force Greaseable	UJ235
	Brute Force Non Greaseable	UJ234		Brute Force Non Greaseable	UJ234
	Clamp Kit (Frnt. Shaft; Frt.)	UJ530-10		Clamp Kit (Frnt. Shaft; Frt.)	UJ530-10
	U-Joint (Frnt. Shaft; Rr.) ^②	UJ534G		U-Joint (Frnt. Shaft; Rr.) ^②	UJ534G
	Brute Force Greaseable	UJ235		Brute Force Greaseable	UJ235
	Brute Force Non Greaseable	UJ234		Brute Force Non Greaseable	UJ234
	Clamp Kit (Frnt. Shaft; Rr.)	UJ530-10		Clamp Kit (Frnt. Shaft; Rr.)	UJ530-10
	U-Joint (Rr. Shaft; Frt.) ^③	UJ331A		U-Joint (Rr. Shaft; Frt.) ^③	UJ534G
	Brute Force Greaseable	UJ232A		Brute Force Greaseable	UJ235
	Brute Force Non Greaseable	UJ234		Brute Force Non Greaseable	UJ234
	Clamp Kit (Rr. Shaft; Frt.)	UJ530-10		Clamp Kit (Rr. Shaft; Frt.)	UJ530-10
	U-Joint (Rr. Shaft; Rr.) ^④	UJ331A		U-Joint (Rr. Shaft; Rr.) ^④	UJ534G
	Brute Force Greaseable	UJ232A		Brute Force Greaseable	UJ235
	Brute Force Non Greaseable	UJ234		Brute Force Non Greaseable	UJ234
	Clamp Kit (Rr. Shaft; Rr.)	UJ530-10		Clamp Kit (Rr. Shaft; Rr.)	UJ530-10

Chevrolet/GMC CUV Equinox

Drive Shaft (AWD)	
U-Joint	
2006-2005 Equinox: [Type 43]	
	U-Joint (Rr. Shaft; Ctr.) ^① UJ10439
	U-Joint (Rr. Shaft; Rr.) ^② UJ10439

Chevrolet/GMC Truck Astro/Safari, Blazer/Jimmy, Colorado/Canyon, Luv, S10 Blazer/S15 Jimmy, S10/S15, Sonoma, SSR, Trailblazer/Envoy

Drive Shaft (2 W/D)	
U-Joint	
2020-2015 Colorado & Canyon w/ 2 Joint Shaft:	
[Type 1]	
	U-Joint (Front) ^① UJ331C
	U-Joint (Rear) ^② UJ331C
2020-2015 Colorado & Canyon w/ 3 Joint Shaft:	
[Type 2]	
	U-Joint (Front) ^① UJ331C
	U-Joint (Center) ^② UJ331C
	U-Joint (Rear) ^③ UJ331C
2012-2004 Canyon & Colorado w/ Reg. Cab:	
[Type 1]	
	U-Joint (Front) ^① UJ354
	Brute Force Greaseable UJ270
	Brute Force Non Greaseable UJ254
	(For Aluminum Drive Shaft) UJ354C
	U-Joint (Rear) ^② UJ355
	Brute Force Greaseable UJ290
	(For Aluminum Drive Shaft) UJ355C
	Clamp Kit (Rear) UJ530-10

Drive Shaft (2 W/D) (Cont.)	
U-Joint (Cont.)	
2012-2004 Canyon & Colorado w/ Ext. Cab & Crew Cab Exc. Z71: [Type 2]	
	U-Joint (Front) ^① UJ354
	Brute Force Greaseable UJ270
	Brute Force Non Greaseable UJ254
	(For Aluminum Drive Shaft) UJ354C
	U-Joint (Center) ^② UJ354
	Brute Force Greaseable UJ270
	Brute Force Non Greaseable UJ254
	(For Aluminum Drive Shaft) UJ354C
	Clamp Kit (Center) UJ437-10
	U-Joint (Rear) ^③ UJ355
	Brute Force Greaseable UJ290
	(For Aluminum Drive Shaft) UJ355C
	Clamp Kit (Rear) UJ530-10
	(Continued)

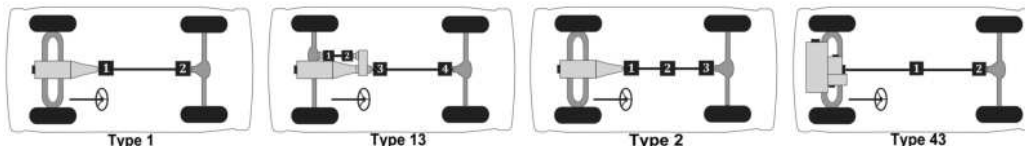

Passenger cars, light & medium trucks

Chevrolet/GMC Truck Astro/Safari, Blazer/Jimmy, Colorado/Canyon, Luv, S10 Blazer/S15 Jimmy, S10/S15, Sonoma, SSR, Trailblazer/Envoy -- (Cont.)

MFG./YEAR	MODEL & LOCATION	PART NO.	MFG./YEAR	MODEL & LOCATION	PART NO.
Drive Shaft (2 W/D) (Cont.)			Drive Shaft (2 W/D) (Cont.)		
U-Joint (Cont.)			U-Joint (Cont.)		
2009 Envoy & Trailblazer: [Type 1]			2005-2003 Astro & Safari: [Type 1]		
U-Joint (Front)⓪		UJ331A	U-Joint (Front)⓪		UJ534G
Brute Force Greaseable		UJ232A	Brute Force Greaseable		UJ235
Clamp Kit (Front)		UJ492-10	Brute Force Non Greaseable		UJ234
U-Joint (Rear)⓪		UJ331A	Clamp Kit (Front)		UJ530-10
Brute Force Greaseable		UJ232A	U-Joint (Rear)⓪		UJ534G
Clamp Kit (Rear)		UJ492-10	Brute Force Greaseable		UJ235
2008-2006 Trailblazer SS: [Type 1]			Brute Force Non Greaseable		UJ234
U-Joint (Front)⓪		UJ331A	Clamp Kit (Rear)		UJ530-10
Brute Force Greaseable		UJ232A	2005-1983 Blazer & Jimmy: [Type 1]		
Clamp Kit (Front)		UJ492-10	U-Joint (Front)⓪		UJ534G
U-Joint (Rear)⓪		UJ331A	Brute Force Greaseable		UJ235
Brute Force Greaseable		UJ232A	Brute Force Non Greaseable		UJ234
Clamp Kit (Rear)		UJ492-10	Clamp Kit (Front)		UJ530-10
2008-2002 Envoy & Trailblazer Exc. SS: [Type 1]			U-Joint (Rear)⓪		UJ534G
U-Joint (Front)⓪		UJ534G	Brute Force Greaseable		UJ235
Brute Force Greaseable		UJ235	Brute Force Non Greaseable		UJ234
Brute Force Non Greaseable		UJ234	Clamp Kit (Rear)		UJ530-10
Clamp Kit (Front)		UJ530-10	2004 S10 Pickup: [Type 1]		
U-Joint (Rear)⓪		UJ534G	U-Joint (Front)⓪		UJ534G
Brute Force Greaseable		UJ235	Brute Force Greaseable		UJ235
Brute Force Non Greaseable		UJ234	Brute Force Non Greaseable		UJ234
Clamp Kit (Rear)		UJ530-10	Clamp Kit (Front)		UJ530-10
2006-2005 SSR w/ Auto. Trans.: [Type 1]			U-Joint (Rear)⓪		UJ534G
U-Joint (Front)⓪		UJ534G	Brute Force Greaseable		UJ235
Brute Force Greaseable		UJ235	Brute Force Non Greaseable		UJ234
Brute Force Non Greaseable		UJ234	Clamp Kit (Rear)		UJ530-10
Clamp Kit (Front)		UJ530-10	2004-2003 SSR: [Type 1]		
U-Joint (Rear)⓪		UJ534G	U-Joint (Front)⓪		UJ534G
Brute Force Greaseable		UJ235	Brute Force Greaseable		UJ235
Brute Force Non Greaseable		UJ234	Brute Force Non Greaseable		UJ234
Clamp Kit (Rear)		UJ530-10	Clamp Kit (Front)		UJ530-10
2006-2005 SSR w/ Man. Trans.: [Type 1]			U-Joint (Rear)⓪		UJ534G
U-Joint (Front)⓪		UJ534G	Brute Force Greaseable		UJ235
Brute Force Greaseable		UJ235	Brute Force Non Greaseable		UJ234
Brute Force Non Greaseable		UJ234	Clamp Kit (Rear)		UJ530-10
Clamp Kit (Front)		UJ530-10	2003-2000 S10 Pickup & Sonoma w/ Ext. Cab.: [Type 2]		
U-Joint (Rear)⓪		UJ331A	U-Joint (Front)⓪		UJ534G
Brute Force Greaseable		UJ232A	Brute Force Greaseable		UJ235
Clamp Kit (Rear)		UJ492-10	Brute Force Non Greaseable		UJ234
2005-2004 Canyon & Colorado Z71 w/ Ext. Cab & Crew Cab: [Type 1]			Clamp Kit (Front)		UJ530-10
U-Joint (Front)⓪		UJ354	U-Joint (Center)⓪		UJ534G
Brute Force Greaseable		UJ270	Brute Force Greaseable		UJ235
Brute Force Non Greaseable		UJ254	Brute Force Non Greaseable		UJ234
(For Aluminum Drive Shaft)		UJ354C	Clamp Kit (Center)		UJ530-10
U-Joint (Rear)⓪		UJ355	U-Joint (Rear)⓪		UJ534G
Brute Force Greaseable		UJ290	Brute Force Greaseable		UJ235
(For Aluminum Drive Shaft)		UJ355C	Brute Force Non Greaseable		UJ234
Clamp Kit (Rear)		UJ530-10	Clamp Kit (Rear)		UJ530-10
			Ball Seat Repair Kit		UJ606

(Continued)

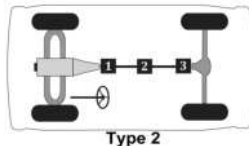
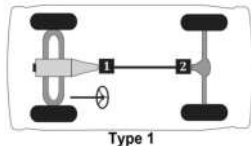

Passenger cars, light & medium trucks

(Cont.) -- Chevrolet/GMC Truck Astro/Safari, Blazer/Jimmy, Colorado/Canyon, Luv, S10 Blazer/S15 Jimmy, S10/S15, Sonoma, SSR, Trailblazer/Envoy

MFG./YEAR	MODEL & LOCATION	PART NO.	MFG./YEAR	MODEL & LOCATION	PART NO.
Drive Shaft (2 W/D) (Cont.)			Drive Shaft (2 W/D) (Cont.)		
U-Joint (Cont.)			U-Joint (Cont.)		
2003-1997 S10 Pickup & Sonoma w/ Reg. Cab.:			1996-1982 S10, S15 & Sonoma Pickups w/ Reg. Cab & Short Bed: [Type 1]		
[Type 1]			[Type 2]		
U-Joint (Front)Ⓢ		UJ534G	U-Joint (Front)Ⓢ		UJ534G
Brute Force Greaseable		UJ235	Brute Force Greaseable		UJ235
Brute Force Non Greaseable		UJ234	Brute Force Non Greaseable		UJ234
Clamp Kit (Front)		UJ530-10	Clamp Kit (Front)		UJ530-10
U-Joint (Rear)Ⓢ		UJ534G	U-Joint (Rear)Ⓢ		UJ534G
Brute Force Greaseable		UJ235	Brute Force Greaseable		UJ235
Brute Force Non Greaseable		UJ234	Brute Force Non Greaseable		UJ234
Clamp Kit (Rear)		UJ530-10	Clamp Kit (Rear)		UJ530-10
Ball Seat Repair Kit		UJ606	1995-1982 S10, S15 & Sonoma Pickups w/ Ext. Cab: [Type 2]		
2002-1985 Astro & Safari: [Type 1]			U-Joint (Front)Ⓢ		
U-Joint (Front)Ⓢ		UJ534G	Brute Force Greaseable		UJ235
Brute Force Greaseable		UJ235	Brute Force Non Greaseable		UJ234
Brute Force Non Greaseable		UJ234	Clamp Kit (Front)		UJ530-10
U-Joint (Rear)Ⓢ		UJ331	U-Joint (Center)Ⓢ		UJ534G
Brute Force Greaseable		UJ232	Brute Force Greaseable		UJ235
Brute Force Non Greaseable		UJ231	Brute Force Non Greaseable		UJ234
(For Aluminum Drive Shaft)		UJ331C	Clamp Kit (Center)		UJ530-10
Clamp Kit (Rear)		UJ331-10	U-Joint (Rear)Ⓢ		UJ534G
1999-1996 S10 Pickup & Sonoma w/ Ext. Cab.:			Brute Force Greaseable		
[Type 2]			UJ235		
U-Joint (Front)Ⓢ		UJ534G	Brute Force Non Greaseable		UJ234
Brute Force Greaseable		UJ235	Clamp Kit (Rear)		UJ530-10
Brute Force Non Greaseable		UJ234	1993-1982 S10, S15 & Sonoma Pickups w/ Reg. Cab & Long Bed: [Type 2]		
Clamp Kit (Front)		UJ530-10	U-Joint (Front)Ⓢ		UJ534G
U-Joint (Center)Ⓢ		UJ534G	Brute Force Greaseable		UJ235
Brute Force Greaseable		UJ235	Brute Force Non Greaseable		UJ234
Brute Force Non Greaseable		UJ234	Clamp Kit (Front)		UJ530-10
Clamp Kit (Center)		UJ530-10	U-Joint (Center)Ⓢ		UJ534G
U-Joint (Rear)Ⓢ		UJ534G	Brute Force Greaseable		UJ235
Brute Force Greaseable		UJ235	Brute Force Non Greaseable		UJ234
Brute Force Non Greaseable		UJ234	Clamp Kit (Center)		UJ530-10
Clamp Kit (Rear)		UJ530-10	U-Joint (Rear)Ⓢ		UJ534G
Ball Seat Repair Kit		UJ606	Brute Force Greaseable		UJ235
1996-1994 S10 Pickup & Sonoma w/ Reg. Cab. & Long Bed: [Type 1]			Brute Force Non Greaseable		UJ234
U-Joint (Front)Ⓢ		UJ354	Clamp Kit (Rear)		UJ530-10
Brute Force Greaseable		UJ270	1982-1972 Luv w/ Long Bed: [Type 2]		
Brute Force Non Greaseable		UJ254	U-Joint (Front)Ⓢ		UJ341
(For Aluminum Drive Shaft)		UJ354C	U-Joint (Center)Ⓢ		UJ341
U-Joint (Rear)Ⓢ		UJ355	U-Joint (Rear)Ⓢ		UJ341
Brute Force Greaseable		UJ290	1982-1972 Luv w/ Standard Bed: [Type 1]		
(For Aluminum Drive Shaft)		UJ355C	U-Joint (Front)Ⓢ		UJ341
Clamp Kit (Rear)		UJ530-10	U-Joint (Rear)Ⓢ		UJ341
			Drive Shaft (4 W/D)		
			U-Joint		
			2020-2016 Colorado & Canyon w/ 2 Joint Rear Shaft:		
			U-Joint (Fr. Shaft; Frt.)		UJ331C
			U-Joint (Rr. Shaft; Frt.)		UJ331C
			U-Joint (Rr. Shaft; Rr.)		UJ331C

(Continued)

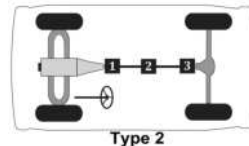
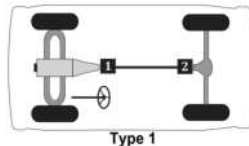

Passenger cars, light & medium trucks

Chevrolet/GMC Truck Astro/Safari, Blazer/Jimmy, Colorado/Canyon, Luv, S10 Blazer/S15 Jimmy, S10/S15, Sonoma, SSR, Trailblazer/Envoy -- (Cont.)

MFG./YEAR	MODEL & LOCATION	PART NO.	MFG./YEAR	MODEL & LOCATION	PART NO.
Drive Shaft (4 W/D) (Cont.)			Drive Shaft (4 W/D) (Cont.)		
U-Joint (Cont.)			U-Joint (Cont.)		
2020-2016 Colorado & Canyon w/ 3 Joint Rear Shaft:			2005-2003 Blazer w/ ZR2 Pkg.: [Type 15]		
U-Joint (Fr. Shaft; Frt.)	UJ331C	U-Joint (Fr. Shaft; Frt.)	UJ445
Brute Force Greaseable	UJ280	Brute Force Greaseable	UJ225
U-Joint (Rr. Shaft; Frt.)	UJ331C	Clamp Kit (Fr. Shaft; Frt.)	UJ360-10
U-Joint (Rr. Shaft; Rr.)	UJ331C	U-Joint (Rr. Shaft; Frt.)	UJ331
2012-2004 Colorado & Canyon: [Type 15]			Brute Force Greaseable	UJ232
U-Joint (Fr. Shaft; Frt.)	UJ369	Brute Force Non Greaseable	UJ231
Brute Force Greaseable	UJ280	(For Aluminum Drive Shaft)	UJ331C
Brute Force Non Greaseable	UJ269	Clamp Kit (Rr. Shaft; Frt.)	UJ492-10
(For Aluminum Drive Shaft)	UJ369C	U-Joint (Rr. Shaft; Rr.)	UJ331
Clamp Kit (Fr. Shaft; Frt.)	UJ360-10	Brute Force Greaseable	UJ232
U-Joint (Rr. Shaft; Frt.)	UJ354	Brute Force Non Greaseable	UJ231
Brute Force Greaseable	UJ270	(For Aluminum Drive Shaft)	UJ331C
Brute Force Non Greaseable	UJ254	Clamp Kit (Rr. Shaft; Rr.)	UJ492-10
(For Aluminum Drive Shaft)	UJ354C	2005-2003 Blazer w/o ZR2 Pkg. & Jimmy: [Type 15]		
U-Joint (Rr. Shaft; Rr.)	UJ355	U-Joint (Fr. Shaft; Frt.)	UJ445
Brute Force Greaseable	UJ290	Brute Force Greaseable	UJ225
(For Aluminum Drive Shaft)	UJ355C	Clamp Kit (Fr. Shaft; Frt.)	UJ360-10
Clamp Kit (Rear)	UJ530-10	U-Joint (Rr. Shaft; Frt.)	UJ534G
2009-2006 Envoy & Trailblazer Exc. SS: [Type 15]			Brute Force Greaseable	UJ235
U-Joint (Fr. Shaft; Frt.)	UJ445	Brute Force Non Greaseable	UJ234
Brute Force Greaseable	UJ225	U-Joint (Rr. Shaft; Rr.)	UJ534G
Clamp Kit (Fr. Shaft; Frt.)	UJ360-10	Brute Force Greaseable	UJ235
U-Joint (Rr. Shaft; Frt.)	UJ534G	Brute Force Non Greaseable	UJ234
Brute Force Greaseable	UJ235	2005-2002 Envoy & Trailblazer: [Type 15]		
Brute Force Non Greaseable	UJ234	U-Joint (Fr. Shaft; Frt.)	UJ445
Clamp Kit (Rr. Shaft; Frt.)	UJ530-10	Brute Force Greaseable	UJ225
U-Joint (Rr. Shaft; Rr.)	UJ534G	Clamp Kit (Fr. Shaft; Frt.)	UJ360-10
Brute Force Greaseable	UJ235	U-Joint (Rr. Shaft; Frt.)	UJ534G
Brute Force Non Greaseable	UJ234	Brute Force Greaseable	UJ235
Clamp Kit (Rr. Shaft; Rr.)	UJ530-10	Brute Force Non Greaseable	UJ234
2006-2006 Trailblazer SS: [Type 15]			Clamp Kit (Rr. Shaft; Frt.)	UJ530-10
U-Joint (Fr. Shaft; Frt.)	UJ445	U-Joint (Rr. Shaft; Rr.)	UJ534G
Brute Force Greaseable	UJ225	Brute Force Greaseable	UJ235
Clamp Kit (Fr. Shaft; Frt.)	UJ360-10	Brute Force Non Greaseable	UJ234
U-Joint (Rr. Shaft; Frt.)	UJ331A	Clamp Kit (Rr. Shaft; Rr.)	UJ530-10
Brute Force Greaseable	UJ232A	2004-1997 S10 Pickup & Sonoma: [Type 15]		
U-Joint (Rr. Shaft; Rr.)	UJ331A	U-Joint (Fr. Shaft; Frt.)	UJ445
Brute Force Greaseable	UJ232A	Brute Force Greaseable	UJ225
			Clamp Kit (Fr. Shaft; Frt.)	UJ360-10
			U-Joint (Rr. Shaft; Frt.)	UJ534G
			Brute Force Greaseable	UJ235
			Brute Force Non Greaseable	UJ234
			Clamp Kit (Rr. Shaft; Frt.)	UJ530-10
			U-Joint (Rr. Shaft; Rr.)	UJ534G
			Brute Force Greaseable	UJ235
			Brute Force Non Greaseable	UJ234
			Clamp Kit (Rr. Shaft; Rr.)	UJ530-10

(Continued)

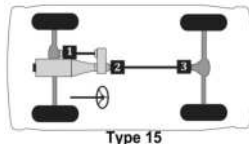

Passenger cars, light & medium trucks

(Cont.) -- Chevrolet/GMC Truck Astro/Safari, Blazer/Jimmy, Colorado/Canyon, Luv, S10 Blazer/S15 Jimmy, S10/S15, Sonoma, SSR, Trailblazer/Envoy

MFG./YEAR	MODEL & LOCATION	PART NO.	MFG./YEAR	MODEL & LOCATION	PART NO.
Drive Shaft (4 W/D) (Cont.)			Drive Shaft (4 W/D) (Cont.)		
U-Joint (Cont.)			U-Joint (Cont.)		
2002-1995 Blazer & Jimmy: [Type 15]			1994 S10 Pickup & Sonoma w/ Ext. Cab.: [Type 16]		
U-Joint (Frnt. Shaft; Frnt.)		UJ445	U-Joint (Frnt. Shaft; Frnt.)		UJ445
Brute Force Greaseable		UJ225	Brute Force Greaseable		UJ225
Clamp Kit (Frnt. Shaft; Frnt.)		UJ360-10	Clamp Kit (Frnt. Shaft; Frnt.)		UJ360-10
U-Joint (Rr. Shaft; Frnt.)		UJ534G	U-Joint (Rr. Shaft; Frnt.)		UJ534G
Brute Force Greaseable		UJ235	Brute Force Greaseable		UJ235
Brute Force Non Greaseable		UJ234	Brute Force Non Greaseable		UJ234
Clamp Kit (Rr. Shaft; Frnt.)		UJ530-10	Clamp Kit (Rr. Shaft; Frnt.)		UJ530-10
U-Joint (Rr. Shaft; Rr.)		UJ534G	U-Joint (Rr. Shaft; Ctr.)		UJ534G
Brute Force Greaseable		UJ235	Brute Force Greaseable		UJ235
Brute Force Non Greaseable		UJ234	Brute Force Non Greaseable		UJ234
Clamp Kit (Rr. Shaft; Rr.)		UJ530-10	Clamp Kit (Rr. Shaft; Ctr.)		UJ530-10
1996-1995 S10 Pickup w/o ZR2 Pkg. & Sonoma: [Type 15]			1994-1988 Blazer & Jimmy w/ Press-On Slip Yoke Seal: [Type 13]		
U-Joint (Frnt. Shaft; Frnt.)		UJ445	U-Joint (Frnt. Shaft; Frnt.)		UJ455
Brute Force Greaseable		UJ225	Clamp Kit (Frnt. Shaft; Frnt.)		UJ360-10
Clamp Kit (Frnt. Shaft; Frnt.)		UJ360-10	U-Joint (Frnt. Shaft; Rr.)		UJ369
U-Joint (Rr. Shaft; Frnt.)		UJ534G	Brute Force Greaseable		UJ280
Brute Force Greaseable		UJ235	Brute Force Non Greaseable		UJ269
Brute Force Non Greaseable		UJ234	(For Aluminum Drive Shaft)		UJ369C
Clamp Kit (Rr. Shaft; Frnt.)		UJ530-10	U-Joint (Rr. Shaft; Frnt.)		UJ534G
U-Joint (Rr. Shaft; Rr.)		UJ534G	Brute Force Greaseable		UJ235
Brute Force Greaseable		UJ235	Brute Force Non Greaseable		UJ234
Brute Force Non Greaseable		UJ234	Clamp Kit (Rr. Shaft; Frnt.)		UJ530-10
Clamp Kit (Rr. Shaft; Rr.)		UJ530-10	U-Joint (Rr. Shaft; Rr.)		UJ534G
1996-1995 S10 Pickup w/ ZR2 Pkg.: [Type 15]			Brute Force Greaseable		UJ235
U-Joint (Frnt. Shaft; Frnt.)		UJ445	Brute Force Non Greaseable		UJ234
Brute Force Greaseable		UJ225	Clamp Kit (Rr. Shaft; Frnt.)		UJ530-10
Clamp Kit (Frnt. Shaft; Frnt.)		UJ360-10	U-Joint (Rr. Shaft; Rr.)		UJ534G
U-Joint (Rr. Shaft; Frnt.)		UJ354	Brute Force Greaseable		UJ235
Brute Force Greaseable		UJ270	Brute Force Non Greaseable		UJ234
Brute Force Non Greaseable		UJ254	(For Aluminum Drive Shaft)		UJ354C
(For Aluminum Drive Shaft)		UJ354C	U-Joint (Rr. Shaft; Rr.)		UJ355
U-Joint (Rr. Shaft; Rr.)		UJ355	Brute Force Greaseable		UJ290
Brute Force Greaseable		UJ290	(For Aluminum Drive Shaft)		UJ355C
(For Aluminum Drive Shaft)		UJ355C	Clamp Kit (Rear)		UJ530-10
Clamp Kit (Rear)		UJ530-10	1994 S10 Pickup & Sonoma w/ Reg. Cab.: [Type 15]		
1994 S10 Pickup & Sonoma w/ Reg. Cab.: [Type 15]			U-Joint (Frnt. Shaft; Frnt.)		UJ445
U-Joint (Frnt. Shaft; Frnt.)		UJ445	Brute Force Greaseable		UJ225
Brute Force Greaseable		UJ225	Clamp Kit (Frnt. Shaft; Frnt.)		UJ360-10
Clamp Kit (Frnt. Shaft; Frnt.)		UJ360-10	U-Joint (Rr. Shaft; Frnt.)		UJ534G
U-Joint (Rr. Shaft; Frnt.)		UJ534G	Brute Force Greaseable		UJ235
Brute Force Greaseable		UJ235	Brute Force Non Greaseable		UJ234
Brute Force Non Greaseable		UJ234	Clamp Kit (Rr. Shaft; Frnt.)		UJ530-10
Clamp Kit (Rr. Shaft; Frnt.)		UJ530-10	U-Joint (Rr. Shaft; Rr.)		UJ534G
U-Joint (Rr. Shaft; Rr.)		UJ534G	Brute Force Greaseable		UJ235
Brute Force Greaseable		UJ235	Brute Force Non Greaseable		UJ234
Brute Force Non Greaseable		UJ234	Clamp Kit (Rr. Shaft; Frnt.)		UJ530-10
Clamp Kit (Rr. Shaft; Rr.)		UJ530-10	U-Joint (Rr. Shaft; Rr.)		UJ534G
U-Joint (Rr. Shaft; Rr.)		UJ534G	Brute Force Greaseable		UJ235
Brute Force Greaseable		UJ235	Brute Force Non Greaseable		UJ234
Brute Force Non Greaseable		UJ234	Clamp Kit (Rr. Shaft; Rr.)		UJ530-10
Clamp Kit (Rr. Shaft; Rr.)		UJ530-10	1994-1988 Blazer & Jimmy w/ Screw-On Slip Yoke Seal: [Type 13]		
1994 S10 Pickup & Sonoma w/ Reg. Cab.: [Type 15]			U-Joint (Frnt. Shaft; Frnt.)		UJ445
U-Joint (Frnt. Shaft; Frnt.)		UJ445	Brute Force Greaseable		UJ225
Brute Force Greaseable		UJ225	Clamp Kit (Frnt. Shaft; Frnt.)		UJ360-10
Clamp Kit (Frnt. Shaft; Frnt.)		UJ360-10	U-Joint (Frnt. Shaft; Rr.)		UJ445
U-Joint (Rr. Shaft; Frnt.)		UJ534G	Brute Force Greaseable		UJ225
Brute Force Greaseable		UJ235	Clamp Kit (Frnt. Shaft; Rr.)		UJ360-10
Brute Force Non Greaseable		UJ234	U-Joint (Rr. Shaft; Frnt.)		UJ534G
Clamp Kit (Rr. Shaft; Frnt.)		UJ530-10	Brute Force Greaseable		UJ235
U-Joint (Rr. Shaft; Rr.)		UJ534G	Brute Force Non Greaseable		UJ234
Brute Force Greaseable		UJ235	Clamp Kit (Rr. Shaft; Frnt.)		UJ530-10
Brute Force Non Greaseable		UJ234	U-Joint (Rr. Shaft; Rr.)		UJ534G
Clamp Kit (Rr. Shaft; Rr.)		UJ530-10	Brute Force Greaseable		UJ235
1994 S10 Pickup & Sonoma w/ Reg. Cab.: [Type 15]			Brute Force Non Greaseable		UJ234
U-Joint (Frnt. Shaft; Frnt.)		UJ445	Clamp Kit (Rr. Shaft; Rr.)		UJ530-10
Brute Force Greaseable		UJ225	(Continued)		
Clamp Kit (Frnt. Shaft; Frnt.)		UJ360-10			
U-Joint (Rr. Shaft; Frnt.)		UJ534G			
Brute Force Greaseable		UJ235			
Brute Force Non Greaseable		UJ234			
Clamp Kit (Rr. Shaft; Frnt.)		UJ530-10			
U-Joint (Rr. Shaft; Rr.)		UJ534G			
Brute Force Greaseable		UJ235			
Brute Force Non Greaseable		UJ234			
Clamp Kit (Rr. Shaft; Rr.)		UJ530-10			

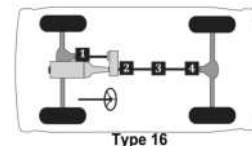
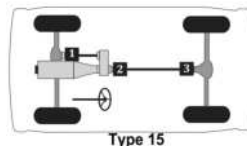
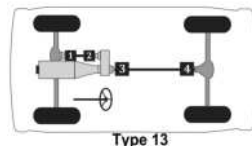

Passenger cars, light & medium trucks

Chevrolet/GMC Truck Astro/Safari, Blazer/Jimmy, Colorado/Canyon, Luv, S10 Blazer/S15 Jimmy, S10/S15, Sonoma, SSR, Trailblazer/Envoy -- (Cont.)

MFG./YEAR	MODEL & LOCATION	PART NO.	MFG./YEAR	MODEL & LOCATION	PART NO.
-----------	------------------	----------	-----------	------------------	----------

Drive Shaft (4 W/D) (Cont.)

U-Joint (Cont.)

**1993-1988 S10 Pickup, S15 Pickup & Sonoma w/
Reg. Cab. & Press-On Slip Yoke Seal:**

[Type 13]

U-Joint (Fr. Shaft; Frt.) ⊙	UJ455
Clamp Kit (Fr. Shaft; Frt.)	UJ360-10
U-Joint (Fr. Shaft; Rr.) ⊙	UJ369
Brute Force Greaseable	UJ280
Brute Force Non Greaseable	UJ269
(For Aluminum Drive Shaft)	UJ369C
Clamp Kit (Fr. Shaft; Rr.)	UJ360-10
U-Joint (Rr. Shaft; Frt.) ⊙	UJ534G
Brute Force Greaseable	UJ235
Brute Force Non Greaseable	UJ234
Clamp Kit (Rr. Shaft; Frt.)	UJ530-10
U-Joint (Rr. Shaft; Rr.) ⊙	UJ534G
Brute Force Greaseable	UJ235
Brute Force Non Greaseable	UJ234
Clamp Kit (Rr. Shaft; Rr.)	UJ530-10

**1993-1988 S10 Pickup, S15 Pickup & Sonoma w/
Reg. Cab. & Screw-On Slip Yoke Seal:**

[Type 13]

U-Joint (Fr. Shaft; Frt.) ⊙	UJ445
Brute Force Greaseable	UJ225
Clamp Kit (Fr. Shaft; Frt.)	UJ360-10
U-Joint (Fr. Shaft; Rr.) ⊙	UJ445
Brute Force Greaseable	UJ225
Clamp Kit (Fr. Shaft; Rr.)	UJ360-10
U-Joint (Rr. Shaft; Frt.) ⊙	UJ534G
Brute Force Greaseable	UJ235
Brute Force Non Greaseable	UJ234
Clamp Kit (Rr. Shaft; Frt.)	UJ530-10
U-Joint (Rr. Shaft; Rr.) ⊙	UJ534G
Brute Force Greaseable	UJ235
Brute Force Non Greaseable	UJ234
Clamp Kit (Rr. Shaft; Rr.)	UJ530-10

Drive Shaft (4 W/D) (Cont.)

U-Joint (Cont.)

**1993-1988 S10 Pickup, S15 Pickup & Sonoma w/
Ext. Cab. & Press-On Slip Yoke Seal:**

[Type 14]

U-Joint (Fr. Shaft; Frt.) ⊙	UJ455
Clamp Kit (Fr. Shaft; Frt.)	UJ360-10
U-Joint (Fr. Shaft; Rr.) ⊙	UJ369
Brute Force Greaseable	UJ280
Brute Force Non Greaseable	UJ269
(For Aluminum Drive Shaft)	UJ369C
Clamp Kit (Fr. Shaft; Rr.)	UJ360-10
U-Joint (Rr. Shaft; Frt.) ⊙	UJ534G
Brute Force Greaseable	UJ235
Brute Force Non Greaseable	UJ234
Clamp Kit (Rr. Shaft; Frt.)	UJ530-10
U-Joint (Rr. Shaft; Ctr.) ⊙	UJ534G
Brute Force Greaseable	UJ235
Brute Force Non Greaseable	UJ234
Clamp Kit (Rr. Shaft; Ctr.)	UJ530-10
U-Joint (Rr. Shaft; Rr.) ⊙	UJ534G
Brute Force Greaseable	UJ235
Brute Force Non Greaseable	UJ234
Clamp Kit (Rr. Shaft; Rr.)	UJ530-10

**1993-1988 S10 Pickup, S15 Pickup & Sonoma w/
Ext. Cab. & Screw-On Slip Yoke Seal:**

[Type 14]

U-Joint (Fr. Shaft; Frt.) ⊙	UJ445
Brute Force Greaseable	UJ225
Clamp Kit (Fr. Shaft; Frt.)	UJ360-10
U-Joint (Fr. Shaft; Rr.) ⊙	UJ445
Brute Force Greaseable	UJ225
Clamp Kit (Fr. Shaft; Rr.)	UJ360-10
U-Joint (Rr. Shaft; Frt.) ⊙	UJ534G
Brute Force Greaseable	UJ235
Brute Force Non Greaseable	UJ234
Clamp Kit (Rr. Shaft; Frt.)	UJ530-10
U-Joint (Rr. Shaft; Ctr.) ⊙	UJ534G
Brute Force Greaseable	UJ235
Brute Force Non Greaseable	UJ234
Clamp Kit (Rr. Shaft; Ctr.)	UJ530-10
U-Joint (Rr. Shaft; Rr.) ⊙	UJ534G
Brute Force Greaseable	UJ235
Brute Force Non Greaseable	UJ234
Clamp Kit (Rr. Shaft; Rr.)	UJ530-10

(Continued)

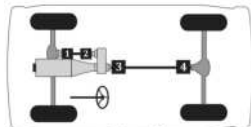

Type 13

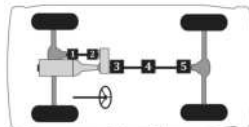

Type 14

Passenger cars, light & medium trucks

(Cont.) -- Chevrolet/GMC Truck Astro/Safari, Blazer/Jimmy, Colorado/Canyon, Luv, S10 Blazer/S15 Jimmy, S10/S15, Sonoma, SSR, Trailblazer/Envoy

MFG./YEAR	MODEL & LOCATION	PART NO.	MFG./YEAR	MODEL & LOCATION	PART NO.
-----------	------------------	----------	-----------	------------------	----------

Drive Shaft (4 W/D) (Cont.)

U-Joint (Cont.)

1987-1983 Blazer & Jimmy: [Type 13]

U-Joint (Frnt. Shaft; Frt.) ^①	UJ445
Brute Force Greaseable	UJ225
Clamp Kit (Frnt. Shaft; Frt.)	UJ360-10
U-Joint (Frnt. Shaft; Rr.) ^②	UJ445
Brute Force Greaseable	UJ225
Clamp Kit (Frnt. Shaft; Rr.)	UJ360-10
U-Joint (Rr. Shaft; Frt.) ^③	UJ534G
Brute Force Greaseable	UJ235
Brute Force Non Greaseable	UJ234
Clamp Kit (Rr. Shaft; Frt.)	UJ530-10
U-Joint (Rr. Shaft; Rr.) ^④	UJ534G
Brute Force Greaseable	UJ235
Brute Force Non Greaseable	UJ234
Clamp Kit (Rr. Shaft; Rr.)	UJ530-10
1987-1983 S10 Pickup & S15 Pickup w/ Reg. Cab.: [Type 13]	
U-Joint (Frnt. Shaft; Frt.) ^①	UJ445
Brute Force Greaseable	UJ225
Clamp Kit (Frnt. Shaft; Frt.)	UJ360-10
U-Joint (Frnt. Shaft; Rr.) ^②	UJ445
Brute Force Greaseable	UJ225
Clamp Kit (Frnt. Shaft; Rr.)	UJ360-10
U-Joint (Rr. Shaft; Frt.) ^③	UJ534G
Brute Force Greaseable	UJ235
Brute Force Non Greaseable	UJ234
Clamp Kit (Rr. Shaft; Frt.)	UJ530-10
U-Joint (Rr. Shaft; Rr.) ^④	UJ534G
Brute Force Greaseable	UJ235
Brute Force Non Greaseable	UJ234
Clamp Kit (Rr. Shaft; Rr.)	UJ530-10

Drive Shaft (4 W/D) (Cont.)

U-Joint (Cont.)

1987-1983 S10 Pickup & S15 Pickup w/ Ext. Cab.:

[Type 14]

U-Joint (Frnt. Shaft; Frt.) ^①	UJ445
Brute Force Greaseable	UJ225
Clamp Kit (Frnt. Shaft; Frt.)	UJ360-10
U-Joint (Frnt. Shaft; Rr.) ^②	UJ445
Brute Force Greaseable	UJ225
Clamp Kit (Frnt. Shaft; Rr.)	UJ360-10
U-Joint (Rr. Shaft; Frt.) ^③	UJ534G
Brute Force Greaseable	UJ235
Brute Force Non Greaseable	UJ234
Clamp Kit (Rr. Shaft; Frt.)	UJ530-10
U-Joint (Rr. Shaft; Ctr.) ^④	UJ534G
Brute Force Greaseable	UJ235
Brute Force Non Greaseable	UJ234
Clamp Kit (Rr. Shaft; Ctr.)	UJ530-10
U-Joint (Rr. Shaft; Rr.) ^⑤	UJ534G
Brute Force Greaseable	UJ235
Brute Force Non Greaseable	UJ234
Clamp Kit (Rr. Shaft; Rr.)	UJ530-10
1982-1979 Luv: [Type 14]	
U-Joint (Frnt. Shaft; Frt.) ^①	UJ341
U-Joint (Frnt. Shaft; Rr.) ^②	UJ383
U-Joint (Rr. Shaft; Frt.) ^③	UJ341
U-Joint (Rr. Shaft; Ctr.) ^④	UJ341
U-Joint (Rr. Shaft; Rr.) ^⑤	UJ341

Drive Shaft (AWD)

U-Joint

2005-2003 Astro & Safari: [Type 15]

U-Joint (Frnt. Shaft; Frt.) ^①	UJ534G
Brute Force Greaseable	UJ235
Brute Force Non Greaseable	UJ234
Clamp Kit (Frnt. Shaft; Frt.)	UJ530-10
U-Joint (Rr. Shaft; Frt.) ^②	UJ534G
Brute Force Greaseable	UJ235
Brute Force Non Greaseable	UJ234
Clamp Kit (Rr. Shaft; Frt.)	UJ530-10
U-Joint (Rr. Shaft; Rr.) ^③	UJ534G
Brute Force Greaseable	UJ235
Brute Force Non Greaseable	UJ234
Clamp Kit (Rr. Shaft; Rr.)	UJ530-10

(Continued)

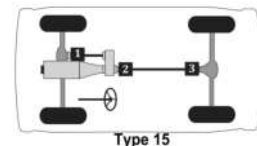
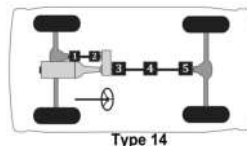
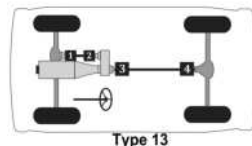

Passenger cars, light & medium trucks

Chevrolet/GMC Truck Astro/Safari, Blazer/Jimmy, Colorado/Canyon, Luv, S10 Blazer/S15 Jimmy, S10/S15, Sonoma, SSR, Trailblazer/Envoy -- (Cont.)

MFG./YEAR	MODEL & LOCATION	PART NO.	MFG./YEAR	MODEL & LOCATION	PART NO.
Drive Shaft (AWD) (Cont.) U-Joint (Cont.)			Drive Shaft (AWD) (Cont.) U-Joint (Cont.)		
			2002-1990 Astro & Safari: [Type 15]		
			U-Joint (Fr. Shaft; Frt.)⊙UJ534G		
			Brute Force GreaseableUJ235		
			Brute Force Non GreaseableUJ234		
			Clamp Kit (Fr. Shaft; Frt.)UJ530-10		
			U-Joint (Rr. Shaft; Frt.)⊙UJ534G		
			Brute Force GreaseableUJ235		
			Brute Force Non GreaseableUJ234		
			Clamp Kit (Rr. Shaft; Frt.)UJ530-10		
			U-Joint (Rr. Shaft; Rr.)⊙UJ331		
			Brute Force GreaseableUJ232		
			Brute Force Non GreaseableUJ231		
			(For Aluminum Drive Shaft)UJ331C		
			Ball Seat Repair KitUJ606		

Chevrolet/GMC Truck LLV (Postal Service)

Drive Shaft (2 W/D) U-Joint	
1995-1987 All: [Type 1]	
U-Joint (Front)⊙UJ534G
Brute Force GreaseableUJ235
Brute Force Non GreaseableUJ234
Clamp Kit (Front)UJ530-10
U-Joint (Rear)⊙UJ534G
Brute Force GreaseableUJ235
Brute Force Non GreaseableUJ234
Clamp Kit (Rear)UJ530-10

Chevrolet/GMC Truck Caballero

Drive Shaft U-Joint	
1987-1979 Caballero: [Type 1]	
U-Joint (Front)⊙UJ534G
Brute Force GreaseableUJ235
Brute Force Non GreaseableUJ234
Clamp Kit (Front)UJ530-10
U-Joint (Rear)⊙UJ534G
Brute Force GreaseableUJ235
Brute Force Non GreaseableUJ234
Clamp Kit (Rear)UJ530-10

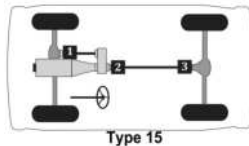
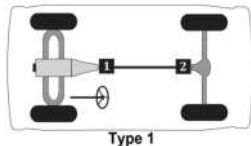

Passenger cars, light & medium trucks

Chevrolet/GMC Truck Tracker

MFG./YEAR	MODEL & LOCATION	PART NO.	MFG./YEAR	MODEL & LOCATION	PART NO.
Drive Shaft (2 W/D)			Drive Shaft (4 W/D)		
U-Joint			U-Joint		
2004-1998 Tracker: [Type 1]			2004-1998 Tracker: [Type 13]		
	U-Joint (Front)ⓐ	UJ398		U-Joint (Frt. Shaft; Frt.)ⓐ	UJ398
	U-Joint (Rear)ⓑ	UJ398		U-Joint (Frt. Shaft; Rr.)ⓑ	UJ398
				U-Joint (Rr. Shaft; Frt.)ⓐ	UJ398
				U-Joint (Rr. Shaft; Rr.)ⓑ	UJ398

Chevrolet/GMC Truck Full Size Vans, 1/2 ton van, 3/4 ton van, 1 ton van

MFG./YEAR	MODEL & LOCATION	PART NO.	MFG./YEAR	MODEL & LOCATION	PART NO.
Drive Shaft (2 W/D)			Drive Shaft (2 W/D) (Cont.)		
U-Joint			U-Joint (Cont.)		
2020-2011 Express 2500 & Savana 2500 w/ 2 Joint Shaft & 1.188" Dia. Brg. Cap: [Type 1]			2020-2011 Express 3500 & Savana 3500 w/ 2 Joint Shaft & 1.188" Dia. Brg. Cap: [Type 1]		
	U-Joint (Front)ⓐ	UJ330		U-Joint (Front)ⓐ	UJ330
	Brute Force Greaseable (For Aluminum Drive Shaft)	UJ295 UJ330C		Brute Force Greaseable (For Aluminum Drive Shaft)	UJ295 UJ330C
	U-Joint (Rear)ⓑ	UJ330		U-Joint (Rear)ⓑ	UJ330
	Brute Force Greaseable (For Aluminum Drive Shaft)	UJ295 UJ330C		Brute Force Greaseable (For Aluminum Drive Shaft)	UJ295 UJ330C
2020-2011 Express 2500 & Savana 2500 w/ 3 Joint Shaft & 1.188" Dia. Brg. Cap: [Type 2]			2020-2011 Express 3500 & Savana 3500 w/ 3 Joint Shaft & 1.188" Dia. Brg. Cap: [Type 2]		
	U-Joint (Front)ⓐ	UJ330		U-Joint (Front)ⓐ	UJ330
	Brute Force Greaseable (For Aluminum Drive Shaft)	UJ295 UJ330C		Brute Force Greaseable (For Aluminum Drive Shaft)	UJ295 UJ330C
	U-Joint (Center)ⓐ	UJ330		U-Joint (Center)ⓐ	UJ330
	Brute Force Greaseable (For Aluminum Drive Shaft)	UJ295 UJ330C		Brute Force Greaseable (For Aluminum Drive Shaft)	UJ295 UJ330C
	U-Joint (Rear)ⓑ	UJ330		U-Joint (Rear)ⓑ	UJ330
	Brute Force Greaseable (For Aluminum Drive Shaft)	UJ295 UJ330C		Brute Force Greaseable (For Aluminum Drive Shaft)	UJ295 UJ330C
2020-2011 Express 2500 & Savana 2500 w/ 2 Joint Shaft & 1.375" Dia. Brg. Cap: [Type 1]			2020-2011 Express 3500 & Savana 3500 w/ 2 Joint Shaft & 1.375" Dia. Brg. Cap: [Type 1]		
	U-Joint (Front)ⓐ	UJ351A		U-Joint (Front)ⓐ	UJ351A
	Brute Force Non Greaseable	UJ351ABF		Brute Force Non Greaseable	UJ351ABF
	U-Joint (Rear)ⓑ	UJ351A		U-Joint (Rear)ⓑ	UJ351A
	Brute Force Non Greaseable	UJ351ABF		Brute Force Non Greaseable	UJ351ABF
2020-2011 Express 2500 & Savana 2500 w/ 3 Joint Shaft & 1.375" Dia. Brg. Cap: [Type 2]			2020-2011 Express 3500 & Savana 3500 w/ 3 Joint Shaft & 1.375" Dia. Brg. Cap: [Type 2]		
	U-Joint (Front)ⓐ	UJ351A		U-Joint (Front)ⓐ	UJ351A
	Brute Force Non Greaseable	UJ351ABF		Brute Force Non Greaseable	UJ351ABF
	U-Joint (Center)ⓐ	UJ351A		U-Joint (Center)ⓐ	UJ351A
	Brute Force Non Greaseable	UJ351ABF		Brute Force Non Greaseable	UJ351ABF
	U-Joint (Rear)ⓑ	UJ351A		U-Joint (Rear)ⓑ	UJ351A
	Brute Force Non Greaseable	UJ351ABF		Brute Force Non Greaseable	UJ351ABF

(Continued)

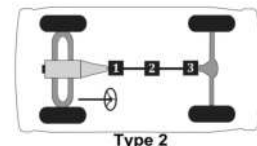
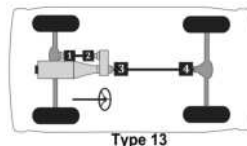
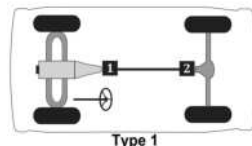

Passenger cars, light & medium trucks

Chevrolet/GMC Truck Full Size Vans, 1/2 ton van, 3/4 ton van, 1 ton van -- (Cont.)

MFG./YEAR	MODEL & LOCATION	PART NO.	MFG./YEAR	MODEL & LOCATION	PART NO.
Drive Shaft (2 W/D) (Cont.)			Drive Shaft (2 W/D) (Cont.)		
U-Joint (Cont.)			U-Joint (Cont.)		
2014-1997 Express 1500 & Savana 1500: [Type 1]			2010-2003 Express 3500 & Savana 3500 w/ 155" Wheel Base Exc. Cutaway: [Type 2]		
U-Joint (Front)⓪		UJ331	U-Joint (Front)⓪		UJ331
Brute Force Greaseable		UJ232	Brute Force Greaseable		UJ232
Brute Force Non Greaseable		UJ231	Brute Force Non Greaseable		UJ231
(For Aluminum Drive Shaft)		UJ331C	(For Aluminum Drive Shaft)		UJ331C
Clamp Kit (Front)		UJ492-10	Clamp Kit (Front)		UJ492-10
U-Joint (Rear)⓪		UJ331	U-Joint (Center)⓪		UJ331
Brute Force Greaseable		UJ232	Brute Force Greaseable		UJ232
Brute Force Non Greaseable		UJ231	Brute Force Non Greaseable		UJ231
(For Aluminum Drive Shaft)		UJ331C	(For Aluminum Drive Shaft)		UJ331C
Clamp Kit (Rear)		UJ492-10	Clamp Kit (Center)		UJ492-10
2010-2005 Express 3500 & Savana 3500 Cutaway w/ 139" Wheel Base & Single Rear Wheels: [Type 1]			U-Joint (Rear)⓪		
U-Joint (Front)⓪		UJ331	Brute Force Greaseable		UJ232
Brute Force Greaseable		UJ232	Brute Force Non Greaseable		UJ231
Brute Force Non Greaseable		UJ231	(For Aluminum Drive Shaft)		UJ331C
(For Aluminum Drive Shaft)		UJ331C	Clamp Kit (Rear)		UJ492-10
Clamp Kit (Front)		UJ492-10	2010-2003 Express 3500 & Savana 3500 Cutaway w/ 159" & 177" Wheel Base: [Type 2]		
U-Joint (Rear)⓪		UJ331	U-Joint (Front)⓪		UJ331
Brute Force Greaseable		UJ232	Brute Force Greaseable		UJ232
Brute Force Non Greaseable		UJ231	Brute Force Non Greaseable		UJ231
(For Aluminum Drive Shaft)		UJ331C	(For Aluminum Drive Shaft)		UJ331C
Clamp Kit (Rear)		UJ492-10	Clamp Kit (Front)		UJ492-10
2010-2005 Express 3500 & Savana 3500 Cutaway w/ 139" Wheel Base & Dual Rear Wheels: [Type 1]			U-Joint (Center)⓪		UJ331
U-Joint (Front)⓪		UJ330	Brute Force Greaseable		UJ232
Brute Force Greaseable		UJ295	Brute Force Non Greaseable		UJ231
(For Aluminum Drive Shaft)		UJ330C	(For Aluminum Drive Shaft)		UJ331C
Clamp Kit (Front)		UJ492-10	Clamp Kit (Center)		UJ492-10
U-Joint (Rear)⓪		UJ330	U-Joint (Rear)⓪		UJ330
Brute Force Greaseable		UJ295	Brute Force Greaseable		UJ295
(For Aluminum Drive Shaft)		UJ330C	(For Aluminum Drive Shaft)		UJ330C
Clamp Kit (Rear)		UJ492-10	Clamp Kit (Rear)		UJ492-10
2010-2003 Express 3500 & Savana 3500 w/ 135" Wheel Base Exc. Cutaway: [Type 1]			2010-1996 Express 2500 & Savana 2500 w/ 135" Wheel Base: [Type 1]		
U-Joint (Front)⓪		UJ331	U-Joint (Front)⓪		UJ331
Brute Force Greaseable		UJ232	Brute Force Greaseable		UJ232
Brute Force Non Greaseable		UJ231	Brute Force Non Greaseable		UJ231
(For Aluminum Drive Shaft)		UJ331C	(For Aluminum Drive Shaft)		UJ331C
Clamp Kit (Front)		UJ492-10	Clamp Kit (Front)		UJ492-10
U-Joint (Rear)⓪		UJ331	U-Joint (Rear)⓪		UJ331
Brute Force Greaseable		UJ232	Brute Force Greaseable		UJ232
Brute Force Non Greaseable		UJ231	Brute Force Non Greaseable		UJ231
(For Aluminum Drive Shaft)		UJ331C	(For Aluminum Drive Shaft)		UJ331C
Clamp Kit (Rear)		UJ492-10	Clamp Kit (Rear)		UJ492-10

(Continued)

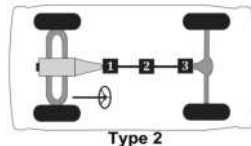
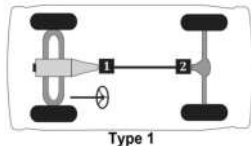

Passenger cars, light & medium trucks

(Cont.) -- Chevrolet/GMC Truck Full Size Vans, 1/2 ton van, 3/4 ton van, 1 ton van

MFG./YEAR	MODEL & LOCATION	PART NO.	MFG./YEAR	MODEL & LOCATION	PART NO.
Drive Shaft (2 W/D) (Cont.)			Drive Shaft (2 W/D) (Cont.)		
U-Joint (Cont.)			U-Joint (Cont.)		
2010-1996 Express 2500 & Savana 2500 w/ 155" Wheel Base: [Type 2]			2002-2001 Express 3500 & Savana 3500 w/ 3 Joint Shaft Exc. Cutaway: [Type 2]		
U-Joint (Front)⓪		UJ331	U-Joint (Front)⓪		UJ331
Brute Force Greaseable		UJ232	Brute Force Greaseable		UJ232
Brute Force Non Greaseable		UJ231	Brute Force Non Greaseable		UJ231
(For Aluminum Drive Shaft)		UJ331C	(For Aluminum Drive Shaft)		UJ331C
Clamp Kit (Front)		UJ492-10	Clamp Kit (Front)		UJ492-10
U-Joint (Center)⓪		UJ331	U-Joint (Center)⓪		UJ331
Brute Force Greaseable		UJ232	Brute Force Greaseable		UJ232
Brute Force Non Greaseable		UJ231	Brute Force Non Greaseable		UJ231
(For Aluminum Drive Shaft)		UJ331C	(For Aluminum Drive Shaft)		UJ331C
Clamp Kit (Center)		UJ492-10	U-Joint (Rear)⓪		UJ331
U-Joint (Rear)⓪		UJ331	Brute Force Greaseable		UJ232
Brute Force Greaseable		UJ232	Brute Force Non Greaseable		UJ231
Brute Force Non Greaseable		UJ231	(For Aluminum Drive Shaft)		UJ331C
(For Aluminum Drive Shaft)		UJ331C	Clamp Kit (Rear)		UJ492-10
Clamp Kit (Rear)		UJ492-10	2002-2001 Express 3500 & Savana 3500 Cutaway w/ 2 Joint Shaft: [Type 1]		
2004-2003 Express 3500 & Savana 3500 Cutaway w/ 139" Wheel Base: [Type 1]			U-Joint (Front)⓪		UJ330
U-Joint (Front)⓪		UJ330	Brute Force Greaseable		UJ295
Brute Force Greaseable		UJ295	(For Aluminum Drive Shaft)		UJ330C
(For Aluminum Drive Shaft)		UJ330C	Clamp Kit (Front)		UJ492-10
Clamp Kit (Front)		UJ492-10	U-Joint (Rear)⓪		UJ330
U-Joint (Rear)⓪		UJ330	Brute Force Greaseable		UJ295
Brute Force Greaseable		UJ295	(For Aluminum Drive Shaft)		UJ330C
(For Aluminum Drive Shaft)		UJ330C	Clamp Kit (Rear)		UJ492-10
Clamp Kit (Rear)		UJ492-10	2002-2001 Express 3500 & Savana 3500 Cutaway w/ 3 Joint Shaft: [Type 2]		
2002-2001 Express 3500 & Savana 3500 w/ 2 Joint Shaft Exc. Cutaway: [Type 1]			U-Joint (Front)⓪		UJ330
U-Joint (Front)⓪		UJ331	Brute Force Greaseable		UJ295
Brute Force Greaseable		UJ232	(For Aluminum Drive Shaft)		UJ330C
Brute Force Non Greaseable		UJ231	Clamp Kit (Front)		UJ492-10
(For Aluminum Drive Shaft)		UJ331C	U-Joint (Center)⓪		UJ330
Clamp Kit (Front)		UJ492-10	Brute Force Greaseable		UJ295
U-Joint (Rear)⓪		UJ331	(For Aluminum Drive Shaft)		UJ330C
Brute Force Greaseable		UJ232	Clamp Kit (Center)		UJ492-10
Brute Force Non Greaseable		UJ231	U-Joint (Rear)⓪		UJ330
(For Aluminum Drive Shaft)		UJ331C	Brute Force Greaseable		UJ295
Clamp Kit (Rear)		UJ492-10	(For Aluminum Drive Shaft)		UJ330C
			Clamp Kit (Rear)		UJ492-10

(Continued)

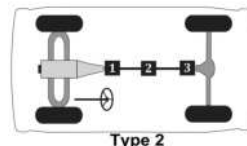
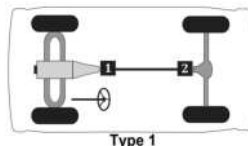

Passenger cars, light & medium trucks

Chevrolet/GMC Truck Full Size Vans, 1/2 ton van, 3/4 ton van, 1 ton van -- (Cont.)

MFG./YEAR	MODEL & LOCATION	PART NO.	MFG./YEAR	MODEL & LOCATION	PART NO.
Drive Shaft (2 W/D) (Cont.)			Drive Shaft (2 W/D) (Cont.)		
U-Joint (Cont.)			U-Joint (Cont.)		
2000-1996 Express 3500 & Savana 3500 w/ 2			1996 Express 2500 & Savana 2500 w/ 110"		
Joint Shaft: [Type 1]			Wheel Base: [Type 1]		
	U-Joint (Front)⓪	UJ331		U-Joint (Front)⓪	UJ534G
	Brute Force Greaseable	UJ232		Brute Force Greaseable	UJ235
	Brute Force Non Greaseable	UJ231		Brute Force Non Greaseable	UJ234
	(For Aluminum Drive Shaft)	UJ331C		Clamp Kit (Front)	UJ530-10
	Clamp Kit (Front)	UJ492-10		U-Joint (Rear)⓪	UJ534G
	U-Joint (Rear)⓪	UJ331		Brute Force Greaseable	UJ235
	Brute Force Greaseable	UJ232		Brute Force Non Greaseable	UJ234
	Brute Force Non Greaseable	UJ231		Clamp Kit (Rear)	UJ530-10
	(For Aluminum Drive Shaft)	UJ331C	1996-1991 G30 & G3500 w/ 2 Joint Shaft: [Type		
	Clamp Kit (Rear)	UJ492-10	1]		
2000-1996 Express 3500 & Savana 3500 w/ 3				U-Joint (Front)⓪	UJ331
Joint Shaft: [Type 2]				Brute Force Greaseable	UJ232
	U-Joint (Front)⓪	UJ331		Brute Force Non Greaseable	UJ231
	Brute Force Greaseable	UJ232		(For Aluminum Drive Shaft)	UJ331C
	Brute Force Non Greaseable	UJ231		Clamp Kit (Front)	UJ492-10
	(For Aluminum Drive Shaft)	UJ331C		U-Joint (Rear)⓪	UJ331
	Clamp Kit (Front)	UJ492-10		Brute Force Greaseable	UJ232
	U-Joint (Center)⓪	UJ331		Brute Force Non Greaseable	UJ231
	Brute Force Greaseable	UJ232		(For Aluminum Drive Shaft)	UJ331C
	Brute Force Non Greaseable	UJ231		Clamp Kit (Rear)	UJ492-10
	(For Aluminum Drive Shaft)	UJ331C	1996-1991 G30 & G3500 w/ 3 Joint Shaft: [Type		
	Clamp Kit (Center)	UJ492-10	2]		
	U-Joint (Rear)⓪	UJ331		U-Joint (Front)⓪	UJ331
	Brute Force Greaseable	UJ232		Brute Force Greaseable	UJ232
	Brute Force Non Greaseable	UJ231		Brute Force Non Greaseable	UJ231
	(For Aluminum Drive Shaft)	UJ331C		(For Aluminum Drive Shaft)	UJ331C
	Clamp Kit (Rear)	UJ492-10		Clamp Kit (Front)	UJ492-10
1996 Express 1500 & Savana 1500 w/ 110"				U-Joint (Center)⓪	UJ331
Wheel Base: [Type 1]				Brute Force Greaseable	UJ232
	U-Joint (Front)⓪	UJ534G		Brute Force Non Greaseable	UJ231
	Brute Force Greaseable	UJ235		(For Aluminum Drive Shaft)	UJ331C
	Brute Force Non Greaseable	UJ234		Clamp Kit (Center)	UJ492-10
	Clamp Kit (Front)	UJ530-10		U-Joint (Rear)⓪	UJ331
	U-Joint (Rear)⓪	UJ534G		Brute Force Greaseable	UJ232
	Brute Force Greaseable	UJ235		Brute Force Non Greaseable	UJ231
	Brute Force Non Greaseable	UJ234		(For Aluminum Drive Shaft)	UJ331C
	Clamp Kit (Rear)	UJ530-10		Clamp Kit (Rear)	UJ492-10
1996 Express 1500 & Savana 1500 w/ 135"			1995-1992 G10 & G1500 w/ 125" Wheel Base &		
Wheel Base: [Type 1]			Alum. Driveshaft: [Type 1]		
	U-Joint (Front)⓪	UJ331		U-Joint (Front)⓪	UJ354
	Brute Force Greaseable	UJ232		Brute Force Greaseable	UJ270
	Brute Force Non Greaseable	UJ231		Brute Force Non Greaseable	UJ254
	(For Aluminum Drive Shaft)	UJ331C		(For Aluminum Drive Shaft)	UJ354C
	Clamp Kit (Front)	UJ492-10		U-Joint (Rear)⓪	UJ355
	U-Joint (Rear)⓪	UJ331		Brute Force Greaseable	UJ290
	Brute Force Greaseable	UJ232		(For Aluminum Drive Shaft)	UJ355C
	Brute Force Non Greaseable	UJ231		Clamp Kit (Rear)	UJ530-10
	(For Aluminum Drive Shaft)	UJ331C			(Continued)
	Clamp Kit (Rear)	UJ492-10			

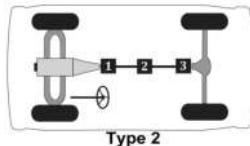
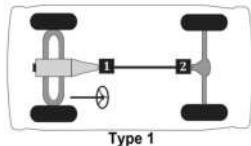

Passenger cars, light & medium trucks

(Cont.) -- Chevrolet/GMC Truck Full Size Vans, 1/2 ton van, 3/4 ton van, 1 ton van

MFG./YEAR	MODEL & LOCATION	PART NO.	MFG./YEAR	MODEL & LOCATION	PART NO.
Drive Shaft (2 W/D) (Cont.)			Drive Shaft (2 W/D) (Cont.)		
U-Joint (Cont.)			U-Joint (Cont.)		
1995-1992 G10 & G1500 w/ 125" Wheel Base & Steel Driveshaft: [Type 1]			1991-1985 G10 & G1500 w/ 125" Wheel Base & 2 Joint Shaft: [Type 1]		
	U-Joint (Front)⓪	UJ534G		U-Joint (Front)⓪	UJ534G
	Brute Force Greaseable	UJ235		Brute Force Greaseable	UJ235
	Brute Force Non Greaseable	UJ234		Brute Force Non Greaseable	UJ234
	Clamp Kit (Front)	UJ530-10		Clamp Kit (Front)	UJ530-10
	U-Joint (Rear)⓪	UJ534G		U-Joint (Rear)⓪	UJ534G
	Brute Force Greaseable	UJ235		Brute Force Greaseable	UJ235
	Brute Force Non Greaseable	UJ234		Brute Force Non Greaseable	UJ234
	Clamp Kit (Rear)	UJ530-10		Clamp Kit (Rear)	UJ530-10
1995-1992 G20 & G2500 w/ 125" Wheel Base & Alum. Driveshaft: [Type 1]			1991-1985 G10 & G1500 w/ 125" Wheel Base & 3 Joint Shaft: [Type 2]		
	U-Joint (Front)⓪	UJ354		U-Joint (Front)⓪	UJ534G
	Brute Force Greaseable	UJ270		Brute Force Greaseable	UJ235
	Brute Force Non Greaseable	UJ254		Brute Force Non Greaseable	UJ234
	(For Aluminum Drive Shaft)	UJ354C		Clamp Kit (Front)	UJ530-10
	U-Joint (Rear)⓪	UJ355		U-Joint (Center)⓪	UJ534G
	Brute Force Greaseable	UJ290		Brute Force Greaseable	UJ235
	(For Aluminum Drive Shaft)	UJ355C		Brute Force Non Greaseable	UJ234
	Clamp Kit (Rear)	UJ530-10		Clamp Kit (Center)	UJ530-10
1995-1992 G20 & G2500 w/ 125" Wheel Base & Steel Driveshaft: [Type 1]			U-Joint (Rear)⓪		
	U-Joint (Front)⓪	UJ534G		Brute Force Greaseable	UJ235
	Brute Force Greaseable	UJ235		Brute Force Non Greaseable	UJ234
	Brute Force Non Greaseable	UJ234		Clamp Kit (Rear)	UJ530-10
	Clamp Kit (Front)	UJ530-10	1991-1985 G20 & G2500 w/ 125" Wheel Base & 3 Joint Shaft: [Type 2]		
	U-Joint (Rear)⓪	UJ534G		U-Joint (Front)⓪	UJ534G
	Brute Force Greaseable	UJ235		Brute Force Greaseable	UJ235
	Brute Force Non Greaseable	UJ234		Brute Force Non Greaseable	UJ234
	Clamp Kit (Rear)	UJ530-10		Clamp Kit (Front)	UJ530-10
1995-1985 G10 & G1500 w/ 110" Wheel Base: [Type 1]				U-Joint (Center)⓪	UJ534G
	U-Joint (Front)⓪	UJ534G		Brute Force Greaseable	UJ235
	Brute Force Greaseable	UJ235		Brute Force Non Greaseable	UJ234
	Brute Force Non Greaseable	UJ234		Clamp Kit (Center)	UJ530-10
	Clamp Kit (Front)	UJ530-10		U-Joint (Rear)⓪	UJ534G
	U-Joint (Rear)⓪	UJ534G		Brute Force Greaseable	UJ235
	Brute Force Greaseable	UJ235		Brute Force Non Greaseable	UJ234
	Brute Force Non Greaseable	UJ234		Clamp Kit (Rear)	UJ530-10
	Clamp Kit (Rear)	UJ530-10	1991-1982 G20 & G2500 w/ 125" Wheel Base & 2 Joint Shaft: [Type 1]		
1995-1985 G20 & G2500 w/ 110" Wheel Base: [Type 1]				U-Joint (Front)⓪	UJ534G
	U-Joint (Front)⓪	UJ534G		Brute Force Greaseable	UJ235
	Brute Force Greaseable	UJ235		Brute Force Non Greaseable	UJ234
	Brute Force Non Greaseable	UJ234		Clamp Kit (Front)	UJ530-10
	Clamp Kit (Front)	UJ530-10		U-Joint (Rear)⓪	UJ534G
	U-Joint (Rear)⓪	UJ534G		Brute Force Greaseable	UJ235
	Brute Force Greaseable	UJ235		Brute Force Non Greaseable	UJ234
	Brute Force Non Greaseable	UJ234		Clamp Kit (Center)	UJ530-10
	Clamp Kit (Rear)	UJ530-10	(Continued)		

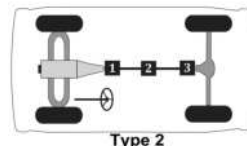
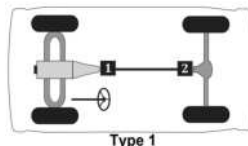

Chevrolet/GMC Truck Full Size Vans, 1/2 ton van, 3/4 ton van, 1 ton van -- (Cont.)

MFG./YEAR	MODEL & LOCATION	PART NO.	MFG./YEAR	MODEL & LOCATION	PART NO.
Drive Shaft (2 W/D) (Cont.)			Drive Shaft (2 W/D) (Cont.)		
U-Joint (Cont.)			U-Joint (Cont.)		
1990-1985 G30 & G3500 w/ 125" Wheel Base & 4 Spd. Auto. Trans.: [Type 2]			1990-1985 G30 & G3500 w/ 146" Wheel Base: [Type 2]		
	U-Joint (Front)Ⓚ	UJ331		U-Joint (Front)Ⓚ	UJ331
	Brute Force Greaseable	UJ232		Brute Force Greaseable	UJ232
	Brute Force Non Greaseable	UJ231		Brute Force Non Greaseable	UJ231
	(For Aluminum Drive Shaft)	UJ331C		(For Aluminum Drive Shaft)	UJ331C
	Clamp Kit (Front)	UJ492-10		Clamp Kit (Front)	UJ492-10
	Clamp Kit (Front)	UJ331-10		Clamp Kit (Front)	UJ331-10
	U-Joint (Center)Ⓛ	UJ331		U-Joint (Center)Ⓛ	UJ331
	Brute Force Greaseable	UJ232		Brute Force Greaseable	UJ232
	Brute Force Non Greaseable	UJ231		Brute Force Non Greaseable	UJ231
	(For Aluminum Drive Shaft)	UJ331C		(For Aluminum Drive Shaft)	UJ331C
	Clamp Kit (Center)	UJ492-10		Clamp Kit (Center)	UJ492-10
	Clamp Kit (Center)	UJ331-10		Clamp Kit (Center)	UJ331-10
	U-Joint (Rear)Ⓛ	UJ331		U-Joint (Rear)Ⓛ	UJ331
	Brute Force Greaseable	UJ232		Brute Force Greaseable	UJ232
	Brute Force Non Greaseable	UJ231		Brute Force Non Greaseable	UJ231
	(For Aluminum Drive Shaft)	UJ331C		(For Aluminum Drive Shaft)	UJ331C
	Clamp Kit (Rear)	UJ492-10		Clamp Kit (Rear)	UJ492-10
	Clamp Kit (Rear)	UJ331-10		Clamp Kit (Rear)	UJ331-10
	1990-1985 G30 & G3500 w/ 125" Wheel Base Exc. 4 Spd. Auto. Trans.: [Type 2]			1989-1985 P20 & P2500 w/ 125" Wheel Base & Auto. Trans.: [Type 2]	
	U-Joint (Front)Ⓚ	UJ534G		U-Joint (Front)Ⓚ	UJ331
	Brute Force Greaseable	UJ235		Brute Force Greaseable	UJ232
	Brute Force Non Greaseable	UJ234		Brute Force Non Greaseable	UJ231
	(For Aluminum Drive Shaft)	UJ331C		(For Aluminum Drive Shaft)	UJ331C
	Clamp Kit (Center)	UJ492-10		Clamp Kit (Front)	UJ492-10
	Clamp Kit (Center)	UJ331-10		U-Joint (Center)Ⓛ	UJ534G
	U-Joint (Rear)Ⓛ	UJ331		Brute Force Greaseable	UJ235
	Brute Force Greaseable	UJ232		Brute Force Non Greaseable	UJ234
	Brute Force Non Greaseable	UJ231		(For Aluminum Drive Shaft)	UJ331C
	(For Aluminum Drive Shaft)	UJ331C		Clamp Kit (Rear)	UJ492-10
	Clamp Kit (Rear)	UJ492-10			(Continued)
	Clamp Kit (Rear)	UJ331-10			

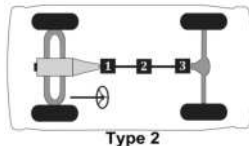

Passenger cars, light & medium trucks

(Cont.) -- Chevrolet/GMC Truck Full Size Vans, 1/2 ton van, 3/4 ton van, 1 ton van

MFG./YEAR	MODEL & LOCATION	PART NO.	MFG./YEAR	MODEL & LOCATION	PART NO.
Drive Shaft (2 W/D) (Cont.)			Drive Shaft (2 W/D) (Cont.)		
U-Joint (Cont.)			U-Joint (Cont.)		
1989-1985 P20 & P2500 w/ 125" Wheel Base & Man. Trans.: [Type 2]			1984 G20 & G2500 w/ 3 Joint Shaft & THM400 Auto. Trans.: [Type 2]		
	U-Joint (Front)⓪	UJ331		U-Joint (Front)⓪	UJ534G
	Brute Force Greaseable	UJ232		Brute Force Greaseable	UJ235
	Brute Force Non Greaseable	UJ231		Brute Force Non Greaseable	UJ234
	(For Aluminum Drive Shaft)	UJ331C		Clamp Kit (Front)	UJ530-10
	Clamp Kit (Front)	UJ492-10		U-Joint (Center)⓪	UJ331
	U-Joint (Center)⓪	UJ331		Brute Force Greaseable	UJ232
	Brute Force Greaseable	UJ232		Brute Force Non Greaseable	UJ231
	Brute Force Non Greaseable	UJ231		(For Aluminum Drive Shaft)	UJ331C
	(For Aluminum Drive Shaft)	UJ331C		Clamp Kit (Center)	UJ492-10
	Clamp Kit (Center)	UJ492-10		U-Joint (Rear)⓪	UJ331
	U-Joint (Rear)⓪	UJ331		Brute Force Greaseable	UJ232
	Brute Force Greaseable	UJ232		Brute Force Non Greaseable	UJ231
	Brute Force Non Greaseable	UJ231		(For Aluminum Drive Shaft)	UJ331C
	(For Aluminum Drive Shaft)	UJ331C		Clamp Kit (Rear)	UJ492-10
	Clamp Kit (Rear)	UJ492-10		1984 G20 & G2500 w/ 3 Joint Shaft Exc. THM400 Auto. Trans.: [Type 2]	
1989-1985 P20 & P2500 w/ 133" Wheel Base & Auto. Trans.: [Type 2]				U-Joint (Front)⓪	UJ534G
	U-Joint (Front)⓪	UJ331		Brute Force Greaseable	UJ235
	Brute Force Greaseable	UJ232		Brute Force Non Greaseable	UJ234
	Brute Force Non Greaseable	UJ231		Clamp Kit (Front)	UJ530-10
	(For Aluminum Drive Shaft)	UJ331C		U-Joint (Center)⓪	UJ534G
	Clamp Kit (Front)	UJ492-10		Brute Force Greaseable	UJ235
	U-Joint (Center)⓪	UJ534G		Brute Force Non Greaseable	UJ234
	Brute Force Greaseable	UJ235		Clamp Kit (Center)	UJ530-10
	Brute Force Non Greaseable	UJ234		U-Joint (Rear)⓪	UJ534G
	U-Joint (Rear)⓪	UJ534G		Brute Force Greaseable	UJ235
	Brute Force Greaseable	UJ235		Brute Force Non Greaseable	UJ234
	Brute Force Non Greaseable	UJ234		Clamp Kit (Rear)	UJ530-10
	Clamp Kit (Rear)	UJ530-10		1984-1983 G30 & G3500 Cab & Chassis: [Type 2]	
1989-1985 P20 & P2500 w/ 133" Wheel Base & Man. Trans.: [Type 2]				U-Joint (Front)⓪	UJ331
	U-Joint (Front)⓪	UJ331		Brute Force Greaseable	UJ232
	Brute Force Greaseable	UJ232		Brute Force Non Greaseable	UJ231
	Brute Force Non Greaseable	UJ231		(For Aluminum Drive Shaft)	UJ331C
	(For Aluminum Drive Shaft)	UJ331C		Clamp Kit (Front)	UJ492-10
	Clamp Kit (Front)	UJ492-10		U-Joint (Center)⓪	UJ331
	U-Joint (Center)⓪	UJ534G		Brute Force Greaseable	UJ232
	Brute Force Greaseable	UJ235		Brute Force Non Greaseable	UJ231
	Brute Force Non Greaseable	UJ234		(For Aluminum Drive Shaft)	UJ331C
	U-Joint (Rear)⓪	UJ331		Clamp Kit (Center)	UJ492-10
	Brute Force Greaseable	UJ232		U-Joint (Rear)⓪	UJ331
	Brute Force Non Greaseable	UJ231		Brute Force Greaseable	UJ232
	(For Aluminum Drive Shaft)	UJ331C		Brute Force Non Greaseable	UJ231
	Clamp Kit (Rear)	UJ492-10		(For Aluminum Drive Shaft)	UJ331C
				Clamp Kit (Rear)	UJ492-10

(Continued)

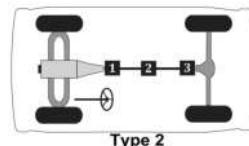

Chevrolet/GMC Truck Full Size Vans, 1/2 ton van, 3/4 ton van, 1 ton van -- (Cont.)

MFG./YEAR	MODEL & LOCATION	PART NO.	MFG./YEAR	MODEL & LOCATION	PART NO.
Drive Shaft (2 W/D) (Cont.)			Drive Shaft (2 W/D) (Cont.)		
U-Joint (Cont.)			U-Joint (Cont.)		
1984-1983 G30 & G3500 Exc. Cab & Chassis:			1984-1982 G10 & G1500 w/ 3 Joint Shaft w/o THM400 Auto. Trans.: [Type 2]		
[Type 2]			[Type 2]		
U-Joint (Front)Ⓛ		UJ534G	U-Joint (Front)Ⓛ		UJ534G
Brute Force Greaseable		UJ235	Brute Force Greaseable		UJ235
Brute Force Non Greaseable		UJ234	Brute Force Non Greaseable		UJ234
U-Joint (Center)Ⓞ		UJ331	Clamp Kit (Front)		UJ530-10
Brute Force Greaseable		UJ232	U-Joint (Center)Ⓞ		UJ534G
Brute Force Non Greaseable		UJ231	Brute Force Greaseable		UJ235
(For Aluminum Drive Shaft)		UJ331C	Brute Force Non Greaseable		UJ234
Clamp Kit (Center)		UJ492-10	Clamp Kit (Center)		UJ530-10
U-Joint (Rear)Ⓞ		UJ331	U-Joint (Rear)Ⓞ		UJ534G
Brute Force Greaseable		UJ232	Brute Force Greaseable		UJ235
Brute Force Non Greaseable		UJ231	Brute Force Non Greaseable		UJ234
(For Aluminum Drive Shaft)		UJ331C	Clamp Kit (Rear)		UJ530-10
Clamp Kit (Rear)		UJ492-10	1984-1982 P20 & P2500: [Type 2]		
1984-1982 G10 & G1500 w/ 2 Joint Shaft: [Type 1]			U-Joint (Front)Ⓛ		UJ331
U-Joint (Front)Ⓛ		UJ534G	Brute Force Greaseable		UJ232
Brute Force Greaseable		UJ235	Brute Force Non Greaseable		UJ231
Brute Force Non Greaseable		UJ234	(For Aluminum Drive Shaft)		UJ331C
Clamp Kit (Front)		UJ530-10	Clamp Kit (Front)		UJ492-10
U-Joint (Rear)Ⓞ		UJ534G	U-Joint (Center)Ⓞ		UJ331
Brute Force Greaseable		UJ235	Brute Force Greaseable		UJ232
Brute Force Non Greaseable		UJ234	Brute Force Non Greaseable		UJ231
(For Aluminum Drive Shaft)		UJ331C	(For Aluminum Drive Shaft)		UJ331C
Clamp Kit (Rear)		UJ530-10	Clamp Kit (Center)		UJ492-10
1984-1982 G10 & G1500 w/ 3 Joint Shaft & THM400 Auto. Trans.: [Type 2]			U-Joint (Rear)Ⓞ		UJ331
U-Joint (Front)Ⓛ		UJ331	Brute Force Greaseable		UJ232
Brute Force Greaseable		UJ232	Brute Force Non Greaseable		UJ231
Brute Force Non Greaseable		UJ231	(For Aluminum Drive Shaft)		UJ331C
(For Aluminum Drive Shaft)		UJ331C	Clamp Kit (Rear)		UJ492-10
U-Joint (Center)Ⓞ		UJ534G	1983-1982 G20 & G2500 w/ 3 Joint Shaft: [Type 2]		
Brute Force Greaseable		UJ235	U-Joint (Front)Ⓛ		UJ534G
Brute Force Non Greaseable		UJ234	Brute Force Greaseable		UJ235
Clamp Kit (Center)		UJ530-10	Brute Force Non Greaseable		UJ234
U-Joint (Rear)Ⓞ		UJ534G	Clamp Kit (Front)		UJ530-10
Brute Force Greaseable		UJ235	U-Joint (Center)Ⓞ		UJ534G
Brute Force Non Greaseable		UJ234	Brute Force Greaseable		UJ235
Clamp Kit (Rear)		UJ530-10	Brute Force Non Greaseable		UJ234
			Clamp Kit (Center)		UJ530-10
			U-Joint (Rear)Ⓞ		UJ534G
			Brute Force Greaseable		UJ235
			Brute Force Non Greaseable		UJ234
			Clamp Kit (Rear)		UJ530-10

(Continued)

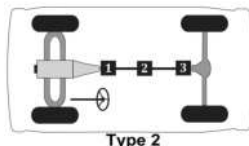
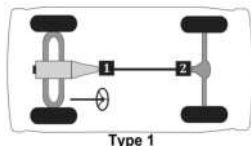

Passenger cars, light & medium trucks

(Cont.) -- Chevrolet/GMC Truck Full Size Vans, 1/2 ton van, 3/4 ton van, 1 ton van

MFG./YEAR	MODEL & LOCATION	PART NO.	MFG./YEAR	MODEL & LOCATION	PART NO.
Drive Shaft (2 W/D) (Cont.)			Drive Shaft (2 W/D) (Cont.)		
U-Joint (Cont.)			U-Joint (Cont.)		
1982	G30 & G3500 Cab & Chassis w/ Auto. Trans.: [Type 2]		1981-1980	G30 & G3500 w/o HD 3 Spd. Man. Trans.: [Type 2]	
	U-Joint (Front)Ⓢ	UJ331		U-Joint (Front)Ⓢ	UJ331
	Brute Force Greaseable	UJ232		Brute Force Greaseable	UJ232
	Brute Force Non Greaseable	UJ231		Brute Force Non Greaseable	UJ231
	(For Aluminum Drive Shaft)	UJ331C		(For Aluminum Drive Shaft)	UJ331C
	Clamp Kit (Front)	UJ492-10		Clamp Kit (Front)	UJ492-10
	U-Joint (Center)Ⓢ	UJ331		U-Joint (Center)Ⓢ	UJ331
	Brute Force Greaseable	UJ232		Brute Force Greaseable	UJ232
	Brute Force Non Greaseable	UJ231		Brute Force Non Greaseable	UJ231
	(For Aluminum Drive Shaft)	UJ331C		(For Aluminum Drive Shaft)	UJ331C
	Clamp Kit (Center)	UJ492-10		Clamp Kit (Center)	UJ492-10
	U-Joint (Rear)Ⓢ	UJ331		U-Joint (Rear)Ⓢ	UJ331
	Brute Force Greaseable	UJ232		Brute Force Greaseable	UJ232
	Brute Force Non Greaseable	UJ231		Brute Force Non Greaseable	UJ231
	(For Aluminum Drive Shaft)	UJ331C		(For Aluminum Drive Shaft)	UJ331C
	Clamp Kit (Rear)	UJ492-10		Clamp Kit (Rear)	UJ492-10
1982	G30 & G3500 Exc. Cab & Chassis w/ Auto. Trans.: [Type 2]		1981-1979	G20 & G2500 w/ 2 Joint Shaft & Inner Lock Rings: [Type 1]	
	U-Joint (Front)Ⓢ	UJ534G		U-Joint (Front)Ⓢ	UJ534G
	Brute Force Greaseable	UJ235		Brute Force Greaseable	UJ235
	Brute Force Non Greaseable	UJ234		Brute Force Non Greaseable	UJ234
	U-Joint (Center)Ⓢ	UJ331		Clamp Kit (Front)	UJ530-10
	Brute Force Greaseable	UJ232		U-Joint (Rear)Ⓢ	UJ534G
	Brute Force Non Greaseable	UJ231		Brute Force Greaseable	UJ235
	(For Aluminum Drive Shaft)	UJ331C		Brute Force Non Greaseable	UJ234
	Clamp Kit (Center)	UJ492-10		Clamp Kit (Rear)	UJ530-10
	U-Joint (Rear)Ⓢ	UJ331		1981-1979 G20 & G2500 w/ 2 Joint Shaft & Outer Lock Rings: [Type 1]	
	Brute Force Greaseable	UJ232		U-Joint (Front)Ⓢ	UJ369
	Brute Force Non Greaseable	UJ231		Brute Force Greaseable	UJ280
	(For Aluminum Drive Shaft)	UJ331C		Brute Force Non Greaseable	UJ269
	Clamp Kit (Rear)	UJ492-10		(For Aluminum Drive Shaft)	UJ369C
1981-1980	G30 & G3500 w/ HD 3 Spd. Man. Trans.: [Type 2]			U-Joint (Rear)Ⓢ	UJ369
	U-Joint (Front)Ⓢ	UJ534G		Brute Force Greaseable	UJ280
	Brute Force Greaseable	UJ235		Brute Force Non Greaseable	UJ269
	Brute Force Non Greaseable	UJ234		(For Aluminum Drive Shaft)	UJ369C
	U-Joint (Center)Ⓢ	UJ331		1981-1979 P20 & P2500 w/ 4 Spd. Man. Trans.: [Type 2]	
	Brute Force Greaseable	UJ232		U-Joint (Front)Ⓢ	UJ331
	Brute Force Non Greaseable	UJ231		Brute Force Greaseable	UJ232
	(For Aluminum Drive Shaft)	UJ331C		Brute Force Non Greaseable	UJ231
	Clamp Kit (Center)	UJ492-10		(For Aluminum Drive Shaft)	UJ331C
	U-Joint (Rear)Ⓢ	UJ331		U-Joint (Center)Ⓢ	UJ331
	Brute Force Greaseable	UJ232		Brute Force Greaseable	UJ232
	Brute Force Non Greaseable	UJ231		Brute Force Non Greaseable	UJ231
	(For Aluminum Drive Shaft)	UJ331C		(For Aluminum Drive Shaft)	UJ331C
	Clamp Kit (Rear)	UJ492-10		U-Joint (Rear)Ⓢ	UJ331
				Brute Force Greaseable	UJ232
				Brute Force Non Greaseable	UJ231
				(For Aluminum Drive Shaft)	UJ331C

(Continued)

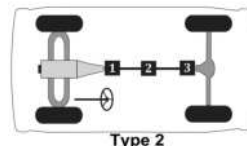
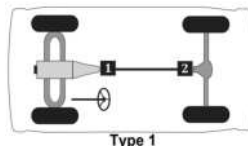

Passenger cars, light & medium trucks

Chevrolet/GMC Truck Full Size Vans, 1/2 ton van, 3/4 ton van, 1 ton van -- (Cont.)

MFG./YEAR	MODEL & LOCATION	PART NO.	MFG./YEAR	MODEL & LOCATION	PART NO.
Drive Shaft (2 W/D) (Cont.)			Drive Shaft (2 W/D) (Cont.)		
U-Joint (Cont.)			U-Joint (Cont.)		
1981-1979 P20 & P2500 Exc. 4 Spd. Man. Trans.:			1981-1978 G10, G15 & G1500 w/ 3 Joint Shaft & 3.5" Yoke: [Type 2]		
[Type 2]					
U-Joint (Front)Ⓚ		UJ331	U-Joint (Front)Ⓚ		UJ534G
Brute Force Greaseable		UJ232	Brute Force Greaseable		UJ235
Brute Force Non Greaseable		UJ231	Brute Force Non Greaseable		UJ234
(For Aluminum Drive Shaft)		UJ331C	Clamp Kit (Front)		UJ530-10
U-Joint (Center)Ⓛ		UJ331	U-Joint (Center)Ⓛ		UJ369
Brute Force Greaseable		UJ232	Brute Force Greaseable		UJ280
Brute Force Non Greaseable		UJ231	Brute Force Non Greaseable		UJ269
(For Aluminum Drive Shaft)		UJ331C	(For Aluminum Drive Shaft)		UJ369C
U-Joint (Rear)Ⓛ		UJ369	Clamp Kit (Center)		UJ360-10
Brute Force Greaseable		UJ280	U-Joint (Rear)Ⓛ		UJ369
Brute Force Non Greaseable		UJ269	Brute Force Greaseable		UJ280
(For Aluminum Drive Shaft)		UJ369C	Brute Force Non Greaseable		UJ269
1981-1978 G10, G15 & G1500 w/ 2 Joint Shaft & Inner Lock Rings: [Type 1]			(For Aluminum Drive Shaft)		UJ369C
U-Joint (Front)Ⓚ		UJ534G	Clamp Kit (Rear)		UJ360-10
Brute Force Greaseable		UJ235	1981-1978 G10, G15 & G1500 w/ 3 Joint Shaft & 4" Yoke: [Type 2]		
Brute Force Non Greaseable		UJ234	U-Joint (Front)Ⓚ		UJ534G
Clamp Kit (Front)		UJ530-10	Brute Force Greaseable		UJ235
U-Joint (Rear)Ⓛ		UJ534G	Brute Force Non Greaseable		UJ234
Brute Force Greaseable		UJ235	Clamp Kit (Front)		UJ530-10
Brute Force Non Greaseable		UJ234	U-Joint (Center)Ⓛ		UJ331
Clamp Kit (Rear)		UJ530-10	Brute Force Greaseable		UJ232
1981-1978 G10, G15 & G1500 w/ 2 Joint Shaft & Outer Lock Rings: [Type 1]			Brute Force Non Greaseable		UJ231
U-Joint (Front)Ⓚ		UJ369	(For Aluminum Drive Shaft)		UJ331C
Brute Force Greaseable		UJ280	U-Joint (Rear)Ⓛ		UJ331
Brute Force Non Greaseable		UJ269	Brute Force Greaseable		UJ232
(For Aluminum Drive Shaft)		UJ369C	Brute Force Non Greaseable		UJ231
Clamp Kit (Front)		UJ360-10	(For Aluminum Drive Shaft)		UJ331C
U-Joint (Rear)Ⓛ		UJ369	1980-1979 P10 & P1500 w/ 4 Spd. Man. Trans.:		
Brute Force Greaseable		UJ280	[Type 1]		
Brute Force Non Greaseable		UJ269	U-Joint (Front)Ⓚ		UJ331
(For Aluminum Drive Shaft)		UJ369C	Brute Force Greaseable		UJ232
Clamp Kit (Rear)		UJ360-10	Brute Force Non Greaseable		UJ231
1981-1978 G10, G15 & G1500 w/ 3 Joint Shaft & 2.563" Yoke: [Type 2]			(For Aluminum Drive Shaft)		UJ331C
U-Joint (Front)Ⓚ		UJ534G	U-Joint (Rear)Ⓛ		UJ369
Brute Force Greaseable		UJ235	Brute Force Greaseable		UJ280
Brute Force Non Greaseable		UJ234	Brute Force Non Greaseable		UJ269
Clamp Kit (Front)		UJ530-10	(For Aluminum Drive Shaft)		UJ369C
U-Joint (Center)Ⓛ		UJ534G	Clamp Kit (Rear)		UJ360-10
Brute Force Greaseable		UJ235	1980-1979 P10 & P1500 w/ THM400 Auto. Trans.:		
Brute Force Non Greaseable		UJ234	[Type 1]		
Clamp Kit (Center)		UJ530-10	U-Joint (Front)Ⓚ		UJ331
U-Joint (Rear)Ⓛ		UJ534G	Brute Force Greaseable		UJ232
Brute Force Greaseable		UJ235	Brute Force Non Greaseable		UJ231
Brute Force Non Greaseable		UJ234	(For Aluminum Drive Shaft)		UJ331C
Clamp Kit (Rear)		UJ530-10	U-Joint (Rear)Ⓛ		UJ369
			Brute Force Greaseable		UJ280
			Brute Force Non Greaseable		UJ269
			(For Aluminum Drive Shaft)		UJ369C
			Clamp Kit (Rear)		UJ360-10

(Continued)

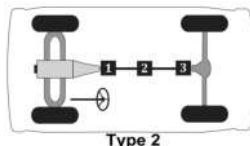
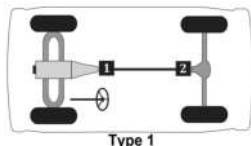

Passenger cars, light & medium trucks

(Cont.) -- Chevrolet/GMC Truck Full Size Vans, 1/2 ton van, 3/4 ton van, 1 ton van

MFG./YEAR	MODEL & LOCATION	PART NO.	MFG./YEAR	MODEL & LOCATION	PART NO.
Drive Shaft (2 W/D) (Cont.)			Drive Shaft (2 W/D) (Cont.)		
U-Joint (Cont.)			U-Joint (Cont.)		
1980-1979 P10 & P1500 w/o 4 Spd. Man. Trans. & THM400 Auto. Trans.: [Type 1]			1979-1978 G30 & G3500 w/ 3 Joint Shaft Exc. THM400 Auto. Trans.: [Type 2]		
U-Joint (Front)⓪		UJ369	U-Joint (Front)⓪		UJ534G
Brute Force Greaseable		UJ280	Brute Force Greaseable		UJ235
Brute Force Non Greaseable		UJ269	Brute Force Non Greaseable		UJ234
(For Aluminum Drive Shaft)		UJ369C	U-Joint (Center)⓪		UJ331
Clamp Kit (Front)		UJ360-10	Brute Force Greaseable		UJ232
U-Joint (Rear)⓪		UJ369	Brute Force Non Greaseable		UJ231
Brute Force Greaseable		UJ280	(For Aluminum Drive Shaft)		UJ331C
Brute Force Non Greaseable		UJ269	Clamp Kit (Center)		UJ492-10
(For Aluminum Drive Shaft)		UJ369C	U-Joint (Rear)⓪		UJ331
Clamp Kit (Rear)		UJ360-10	Brute Force Greaseable		UJ232
1979-1978 G30 & G3500 w/ 2 Joint Shaft: [Type 1]			Brute Force Non Greaseable		UJ231
U-Joint (Front)⓪		UJ331	(For Aluminum Drive Shaft)		UJ331C
Brute Force Greaseable		UJ232	Clamp Kit (Rear)		UJ492-10
Brute Force Non Greaseable		UJ231	1978-1976 G20 & G25 w/ 2 Joint Shaft & 400 Eng.: [Type 1]		
(For Aluminum Drive Shaft)		UJ331C	U-Joint (Front)⓪		UJ534G
Clamp Kit (Front)		UJ492-10	Brute Force Greaseable		UJ235
U-Joint (Rear)⓪		UJ331	Brute Force Non Greaseable		UJ234
Brute Force Greaseable		UJ232	U-Joint (Rear)⓪		UJ355
Brute Force Non Greaseable		UJ231	Brute Force Greaseable		UJ290
(For Aluminum Drive Shaft)		UJ331C	(For Aluminum Drive Shaft)		UJ355C
Clamp Kit (Rear)		UJ492-10	1978-1976 G20 & G25 w/ 3 Joint Shaft & 400 Eng.: [Type 2]		
1979-1978 G30 & G3500 w/ 3 Joint Shaft & THM400 Auto. Trans.: [Type 2]			U-Joint (Front)⓪		UJ534G
U-Joint (Front)⓪		UJ534G	Brute Force Greaseable		UJ235
Brute Force Greaseable		UJ235	Brute Force Non Greaseable		UJ234
Brute Force Non Greaseable		UJ234	U-Joint (Center)⓪		UJ331
Clamp Kit (Front)		UJ530-10	Brute Force Greaseable		UJ232
U-Joint (Center)⓪		UJ331	Brute Force Non Greaseable		UJ231
Brute Force Greaseable		UJ232	(For Aluminum Drive Shaft)		UJ331C
Brute Force Non Greaseable		UJ231	U-Joint (Rear)⓪		UJ354
(For Aluminum Drive Shaft)		UJ331C	Brute Force Greaseable		UJ270
Clamp Kit (Center)		UJ492-10	Brute Force Non Greaseable		UJ254
U-Joint (Rear)⓪		UJ331	(For Aluminum Drive Shaft)		UJ354C
Brute Force Greaseable		UJ232	1978-1976 G20 & G25 w/ 2 Joint Shaft Exc. 400 Eng.: [Type 1]		
Brute Force Non Greaseable		UJ231	U-Joint (Front)⓪		UJ369
(For Aluminum Drive Shaft)		UJ331C	Brute Force Greaseable		UJ280
Clamp Kit (Rear)		UJ492-10	Brute Force Non Greaseable		UJ269
			(For Aluminum Drive Shaft)		UJ369C
			Clamp Kit (Front)		UJ360-10
			U-Joint (Rear)⓪		UJ369
			Brute Force Greaseable		UJ280
			Brute Force Non Greaseable		UJ269
			(For Aluminum Drive Shaft)		UJ369C
			Clamp Kit (Rear)		UJ360-10

(Continued)

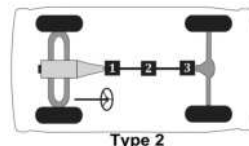
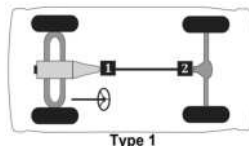

Passenger cars, light & medium trucks

Chevrolet/GMC Truck Full Size Vans, 1/2 ton van, 3/4 ton van, 1 ton van -- (Cont.)



MFG./YEAR	MODEL & LOCATION	PART NO.	MFG./YEAR	MODEL & LOCATION	PART NO.
-----------	------------------	----------	-----------	------------------	----------

Drive Shaft (2 W/D) (Cont.)

U-Joint (Cont.)



1978-1976 G20 & G25 w/ 3 Joint Shaft Exc. 400

Eng.: [Type 2]

U-Joint (Front) 	UJ369
Brute Force Greaseable	UJ280
Brute Force Non Greaseable	UJ269
(For Aluminum Drive Shaft)	UJ369C
Clamp Kit (Front)	UJ360-10
U-Joint (Center) 	UJ369
Brute Force Greaseable	UJ280
Brute Force Non Greaseable	UJ269
(For Aluminum Drive Shaft)	UJ369C
Clamp Kit (Center)	UJ360-10
U-Joint (Rear) 	UJ369
Brute Force Greaseable	UJ280
Brute Force Non Greaseable	UJ269
(For Aluminum Drive Shaft)	UJ369C
Clamp Kit (Rear)	UJ360-10



1978-1976 P20 & P25 w/ 2 Joint Shaft, HD 3 Spd.

& 4 Spd. Man. Trans.: [Type 1]

U-Joint (Front) 	UJ331
Brute Force Greaseable	UJ232
Brute Force Non Greaseable	UJ231
(For Aluminum Drive Shaft)	UJ331C
U-Joint (Rear) 	UJ331
Brute Force Greaseable	UJ232
Brute Force Non Greaseable	UJ231
(For Aluminum Drive Shaft)	UJ331C

1978-1976 P20 & P25 w/ 2 Joint Shaft Exc. HD 3

Spd. & 4 Spd. Man. Trans.: [Type 1]



U-Joint (Front) 	UJ369
Brute Force Greaseable	UJ280
Brute Force Non Greaseable	UJ269
(For Aluminum Drive Shaft)	UJ369C
Clamp Kit (Front)	UJ360-10
U-Joint (Rear) 	UJ369
Brute Force Greaseable	UJ280
Brute Force Non Greaseable	UJ269
(For Aluminum Drive Shaft)	UJ369C
Clamp Kit (Rear)	UJ360-10

Drive Shaft (2 W/D) (Cont.)

U-Joint (Cont.)



1978-1976 P20 & P25 w/ 3 Joint Shaft, HD 3 Spd.

& 4 Spd. Man. Trans.: [Type 2]



U-Joint (Front) 	UJ331
Brute Force Greaseable	UJ232
Brute Force Non Greaseable	UJ231
(For Aluminum Drive Shaft)	UJ331C
U-Joint (Center) 	UJ331
Brute Force Greaseable	UJ232
Brute Force Non Greaseable	UJ231
(For Aluminum Drive Shaft)	UJ331C
U-Joint (Rear) 	UJ331
Brute Force Greaseable	UJ232
Brute Force Non Greaseable	UJ231
(For Aluminum Drive Shaft)	UJ331C

1978-1976 P20 & P25 w/ 3 Joint Shaft Exc. HD 3

Spd. & 4 Spd. Man. Trans.: [Type 2]



U-Joint (Front) 	UJ369
Brute Force Greaseable	UJ280
Brute Force Non Greaseable	UJ269
(For Aluminum Drive Shaft)	UJ369C
Clamp Kit (Front)	UJ360-10
U-Joint (Center) 	UJ369
Brute Force Greaseable	UJ280
Brute Force Non Greaseable	UJ269
(For Aluminum Drive Shaft)	UJ369C
Clamp Kit (Center)	UJ360-10
U-Joint (Rear) 	UJ331
Brute Force Greaseable	UJ232
Brute Force Non Greaseable	UJ231
(For Aluminum Drive Shaft)	UJ331C

1978-1976 P35 w/ 2 Joint Shaft: [Type 1]

U-Joint (Front) 	UJ427
U-Joint (Rear) 	UJ427
U-Joint (Steering Shaft)	UJ861

1978-1973 P10 & P15 w/ 2 Joint Shaft, HD 3 Spd.

& 4 Spd. Man. Trans.: [Type 1]

U-Joint (Front) 	UJ331
Brute Force Greaseable	UJ232
Brute Force Non Greaseable	UJ231
(For Aluminum Drive Shaft)	UJ331C
U-Joint (Rear) 	UJ369
Brute Force Greaseable	UJ280
Brute Force Non Greaseable	UJ269
(For Aluminum Drive Shaft)	UJ369C
Clamp Kit (Rear)	UJ360-10

(Continued)

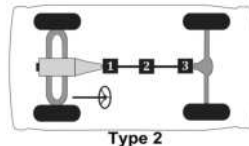
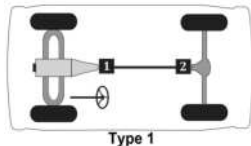

Passenger cars, light & medium trucks

(Cont.) -- Chevrolet/GMC Truck Full Size Vans, 1/2 ton van, 3/4 ton van, 1 ton van

MFG./YEAR	MODEL & LOCATION	PART NO.	MFG./YEAR	MODEL & LOCATION	PART NO.
Drive Shaft (2 W/D) (Cont.)			Drive Shaft (2 W/D) (Cont.)		
U-Joint (Cont.)			U-Joint (Cont.)		
1978-1973 P10 & P15 w/ 2 Joint Shaft w/o HD 3 Spd. & 4 Spd. Man. Trans.: [Type 1]			1977-1975 G30 & G35 w/ 2 Joint Shaft & 400 Eng.: [Type 1]		
	U-Joint (Front)⓪	UJ369		U-Joint (Front)⓪	UJ354
	Brute Force Greaseable	UJ280		Brute Force Greaseable	UJ270
	Brute Force Non Greaseable	UJ269		Brute Force Non Greaseable	UJ254
	(For Aluminum Drive Shaft)	UJ369C		(For Aluminum Drive Shaft)	UJ354C
	Clamp Kit (Front)	UJ360-10		U-Joint (Rear)⓪	UJ331
	U-Joint (Rear)⓪	UJ369		Brute Force Greaseable	UJ232
	Brute Force Greaseable	UJ280		Brute Force Non Greaseable	UJ231
	Brute Force Non Greaseable	UJ269		(For Aluminum Drive Shaft)	UJ331C
	(For Aluminum Drive Shaft)	UJ369C		U-Bolt Kit (Rear)	UJ330-10
	Clamp Kit (Rear)	UJ360-10		1977-1975 G30 & G35 w/ 2 Joint Shaft Exc. 400 Eng.: [Type 1]	
1978-1973 P10 & P15 w/ 3 Joint Shaft, HD 3 Spd. & 4 Spd. Man. Trans.: [Type 2]				U-Joint (Front)⓪	UJ369
	U-Joint (Front)⓪	UJ331		Brute Force Greaseable	UJ280
	Brute Force Greaseable	UJ232		Brute Force Non Greaseable	UJ269
	Brute Force Non Greaseable	UJ231		(For Aluminum Drive Shaft)	UJ369C
	(For Aluminum Drive Shaft)	UJ331C		Clamp Kit (Front)	UJ360-10
	U-Joint (Center)⓪	UJ369		U-Joint (Rear)⓪	UJ369
	Brute Force Greaseable	UJ280		Brute Force Greaseable	UJ280
	Brute Force Non Greaseable	UJ269		Brute Force Non Greaseable	UJ269
	(For Aluminum Drive Shaft)	UJ369C		(For Aluminum Drive Shaft)	UJ369C
	Clamp Kit (Center)	UJ360-10		Clamp Kit (Rear)	UJ360-10
	U-Joint (Rear)⓪	UJ369		1977-1975 G30 & G35 w/ 3 Joint Shaft & 400 Eng.: [Type 2]	
	Brute Force Greaseable	UJ280		U-Joint (Front)⓪	UJ354
	Brute Force Non Greaseable	UJ269		Brute Force Greaseable	UJ270
	(For Aluminum Drive Shaft)	UJ369C		Brute Force Non Greaseable	UJ254
	Clamp Kit (Rear)	UJ360-10		(For Aluminum Drive Shaft)	UJ354C
1978-1973 P10 & P15 w/ 3 Joint Shaft w/o HD 3 Spd. & 4 Spd. Man. Trans.: [Type 2]				U-Joint (Center)⓪	UJ331
	U-Joint (Front)⓪	UJ369		Brute Force Greaseable	UJ232
	Brute Force Greaseable	UJ280		Brute Force Non Greaseable	UJ231
	Brute Force Non Greaseable	UJ269		(For Aluminum Drive Shaft)	UJ331C
	(For Aluminum Drive Shaft)	UJ369C		U-Bolt Kit (Center)	UJ330-10
	Clamp Kit (Front)	UJ360-10		U-Joint (Rear)⓪	UJ331
	U-Joint (Center)⓪	UJ369		Brute Force Greaseable	UJ232
	Brute Force Greaseable	UJ280		Brute Force Non Greaseable	UJ231
	Brute Force Non Greaseable	UJ269		(For Aluminum Drive Shaft)	UJ331C
	(For Aluminum Drive Shaft)	UJ369C		U-Bolt Kit (Rear)	UJ330-10
	Clamp Kit (Center)	UJ360-10			(Continued)
	U-Joint (Rear)⓪	UJ369			
	Brute Force Greaseable	UJ280			
	Brute Force Non Greaseable	UJ269			
	(For Aluminum Drive Shaft)	UJ369C			
	Clamp Kit (Rear)	UJ360-10			

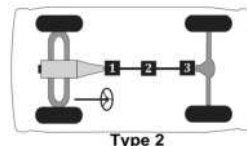
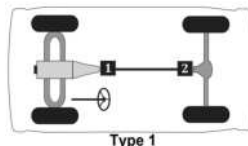

Passenger cars, light & medium trucks

Chevrolet/GMC Truck Full Size Vans, 1/2 ton van, 3/4 ton van, 1 ton van -- (Cont.)

MFG./YEAR	MODEL & LOCATION	PART NO.	MFG./YEAR	MODEL & LOCATION	PART NO.
Drive Shaft (2 W/D) (Cont.)			Drive Shaft (2 W/D) (Cont.)		
U-Joint (Cont.)			U-Joint (Cont.)		
1977-1975 G30 & G35 w/ 3 Joint Shaft Exc. 400			1975-1973 G20 & G25 w/ 2 Joint Shaft: [Type 1]		
Eng.: [Type 2]					
	U-Joint (Front)Ⓛ	UJ369		U-Joint (Front)Ⓛ	UJ369
	<i>Brute Force Greaseable</i>	UJ280		<i>Brute Force Greaseable</i>	UJ280
	<i>Brute Force Non Greaseable</i>	UJ269		<i>Brute Force Non Greaseable</i>	UJ269
	(For Aluminum Drive Shaft)	UJ369C		(For Aluminum Drive Shaft)	UJ369C
	Clamp Kit (Front)	UJ360-10		Clamp Kit (Front)	UJ360-10
	U-Joint (Center)Ⓛ	UJ331		U-Joint (Rear)Ⓛ	UJ369
	<i>Brute Force Greaseable</i>	UJ232		<i>Brute Force Greaseable</i>	UJ280
	<i>Brute Force Non Greaseable</i>	UJ231		<i>Brute Force Non Greaseable</i>	UJ269
	(For Aluminum Drive Shaft)	UJ331C		(For Aluminum Drive Shaft)	UJ369C
	U-Bolt Kit (Center)	UJ330-10		Clamp Kit (Rear)	UJ360-10
	U-Joint (Rear)Ⓛ	UJ331		1975-1973 G20 & G25 w/ 3 Joint Shaft: [Type 2]	
	<i>Brute Force Greaseable</i>	UJ232		U-Joint (Front)Ⓛ	UJ369
	<i>Brute Force Non Greaseable</i>	UJ231		<i>Brute Force Greaseable</i>	UJ280
	(For Aluminum Drive Shaft)	UJ331C		<i>Brute Force Non Greaseable</i>	UJ269
	U-Bolt Kit (Rear)	UJ330-10		(For Aluminum Drive Shaft)	UJ369C
	1977-1972 G10 & G15 w/ 2 Joint Shaft: [Type 1]			Clamp Kit (Front)	UJ360-10
	U-Joint (Front)Ⓛ	UJ369		U-Joint (Center)Ⓛ	UJ369
	<i>Brute Force Greaseable</i>	UJ280		<i>Brute Force Greaseable</i>	UJ280
	<i>Brute Force Non Greaseable</i>	UJ269		<i>Brute Force Non Greaseable</i>	UJ269
	(For Aluminum Drive Shaft)	UJ369C		(For Aluminum Drive Shaft)	UJ369C
	Clamp Kit (Front)	UJ360-10		Clamp Kit (Center)	UJ360-10
	U-Joint (Rear)Ⓛ	UJ369		U-Joint (Rear)Ⓛ	UJ369
	<i>Brute Force Greaseable</i>	UJ280		<i>Brute Force Greaseable</i>	UJ280
	<i>Brute Force Non Greaseable</i>	UJ269		<i>Brute Force Non Greaseable</i>	UJ269
	(For Aluminum Drive Shaft)	UJ369C		(For Aluminum Drive Shaft)	UJ369C
	Clamp Kit (Rear)	UJ360-10		Clamp Kit (Rear)	UJ360-10
	1977-1972 G10 & G15 w/ 3 Joint Shaft: [Type 2]			1975-1967 P20 & P25 w/ 3 Spd. Man. Trans.: [Type 2]	
	U-Joint (Front)Ⓛ	UJ369		U-Joint (Front)Ⓛ	UJ369
	<i>Brute Force Greaseable</i>	UJ280		<i>Brute Force Greaseable</i>	UJ280
	<i>Brute Force Non Greaseable</i>	UJ269		<i>Brute Force Non Greaseable</i>	UJ269
	(For Aluminum Drive Shaft)	UJ369C		(For Aluminum Drive Shaft)	UJ369C
	Clamp Kit (Front)	UJ360-10		Clamp Kit (Front)	UJ360-10
	U-Joint (Center)Ⓛ	UJ369		U-Joint (Center)Ⓛ	UJ331
	<i>Brute Force Greaseable</i>	UJ280		<i>Brute Force Greaseable</i>	UJ232
	<i>Brute Force Non Greaseable</i>	UJ269		<i>Brute Force Non Greaseable</i>	UJ231
	(For Aluminum Drive Shaft)	UJ369C		(For Aluminum Drive Shaft)	UJ331C
	Clamp Kit (Center)	UJ360-10		U-Joint (Rear)Ⓛ	UJ331
	U-Joint (Rear)Ⓛ	UJ369		<i>Brute Force Greaseable</i>	UJ232
	<i>Brute Force Greaseable</i>	UJ280		<i>Brute Force Non Greaseable</i>	UJ231
	<i>Brute Force Non Greaseable</i>	UJ269		(For Aluminum Drive Shaft)	UJ331C
	(For Aluminum Drive Shaft)	UJ369C			
	Clamp Kit (Rear)	UJ360-10			

(Continued)

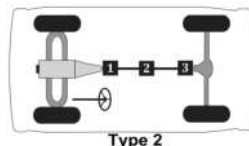
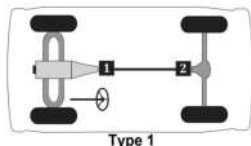

Passenger cars, light & medium trucks

(Cont.) -- Chevrolet/GMC Truck Full Size Vans, 1/2 ton van, 3/4 ton van, 1 ton van

MFG./YEAR	MODEL & LOCATION	PART NO.	MFG./YEAR	MODEL & LOCATION	PART NO.
Drive Shaft (2 W/D) (Cont.)			Drive Shaft (2 W/D) (Cont.)		
U-Joint (Cont.)			U-Joint (Cont.)		
1975-1967 P20 & P25 w/ 4 Spd. Man. Trans.:			1974-1971 G30 & G35 w/ 2 Joint Shaft: [Type 1]		
[Type 2]			U-Joint (Front)ⓐ UJ331		
U-Joint (Front)ⓐ UJ331			Brute Force Greaseable UJ280		
Brute Force Greaseable UJ232			Brute Force Non Greaseable UJ269		
Brute Force Non Greaseable UJ231			(For Aluminum Drive Shaft) UJ369C		
(For Aluminum Drive Shaft) UJ331C			U-Bolt Kit (Front) UJ329-10		
U-Joint (Center)ⓑ UJ331			U-Joint (Rear)ⓑ UJ369		
Brute Force Greaseable UJ232			Brute Force Greaseable UJ280		
Brute Force Non Greaseable UJ231			Brute Force Non Greaseable UJ269		
(For Aluminum Drive Shaft) UJ331C			(For Aluminum Drive Shaft) UJ369C		
U-Joint (Rear)ⓑ UJ331			U-Bolt Kit (Rear) UJ329-10		
Brute Force Greaseable UJ232			1972-1967 G20 & G25 w/ 2 Joint Shaft: [Type 1]		
Brute Force Non Greaseable UJ231			U-Joint (Front)ⓐ UJ369		
(For Aluminum Drive Shaft) UJ331C			Brute Force Greaseable UJ280		
1975-1967 P20 & P25 w/ Auto. Trans.: [Type 2]			Brute Force Non Greaseable UJ269		
U-Joint (Front)ⓐ UJ369			(For Aluminum Drive Shaft) UJ369C		
Brute Force Greaseable UJ280			U-Bolt Kit (Front) UJ329-10		
Brute Force Non Greaseable UJ269			U-Joint (Rear)ⓑ UJ369		
(For Aluminum Drive Shaft) UJ369C			Brute Force Greaseable UJ280		
Clamp Kit (Front) UJ360-10			Brute Force Non Greaseable UJ269		
U-Joint (Center)ⓑ UJ331			(For Aluminum Drive Shaft) UJ369C		
Brute Force Greaseable UJ232			U-Bolt Kit (Rear) UJ329-10		
Brute Force Non Greaseable UJ231			1972-1967 G20 & G25 w/ 3 Joint Shaft: [Type 2]		
(For Aluminum Drive Shaft) UJ331C			U-Joint (Front)ⓐ UJ369		
U-Joint (Rear)ⓑ UJ331			Brute Force Greaseable UJ280		
Brute Force Greaseable UJ232			Brute Force Non Greaseable UJ269		
Brute Force Non Greaseable UJ231			(For Aluminum Drive Shaft) UJ369C		
(For Aluminum Drive Shaft) UJ331C			U-Bolt Kit (Front) UJ329-10		
U-Joint (Center)ⓑ UJ331			U-Joint (Center)ⓑ UJ369		
Brute Force Greaseable UJ232			Brute Force Greaseable UJ280		
Brute Force Non Greaseable UJ231			Brute Force Non Greaseable UJ269		
(For Aluminum Drive Shaft) UJ331C			(For Aluminum Drive Shaft) UJ369C		
U-Joint (Rear)ⓑ UJ331			U-Bolt Kit (Center) UJ329-10		
Brute Force Greaseable UJ232			U-Joint (Rear)ⓑ UJ369		
Brute Force Non Greaseable UJ231			Brute Force Greaseable UJ280		
(For Aluminum Drive Shaft) UJ331C			Brute Force Non Greaseable UJ269		
U-Joint (Front)ⓐ UJ369			(For Aluminum Drive Shaft) UJ369C		
Brute Force Greaseable UJ280			U-Bolt Kit (Rear) UJ329-10		
Brute Force Non Greaseable UJ269			1972-1961 P10 & P15 w/ 2 Joint Shaft, HD 3 Spd.		
(For Aluminum Drive Shaft) UJ369C			& 4 Spd. Man. Trans.: [Type 1]		
U-Bolt Kit (Center) UJ329-10			U-Joint (Front)ⓐ UJ331		
U-Joint (Rear)ⓑ UJ369			Brute Force Greaseable UJ232		
Brute Force Greaseable UJ280			Brute Force Non Greaseable UJ231		
Brute Force Non Greaseable UJ269			(For Aluminum Drive Shaft) UJ331C		
(For Aluminum Drive Shaft) UJ369C			U-Joint (Rear)ⓑ UJ369		
U-Bolt Kit (Rear) UJ329-10			Brute Force Greaseable UJ280		
			Brute Force Non Greaseable UJ269		
			(For Aluminum Drive Shaft) UJ369C		
			U-Bolt Kit (Rear) UJ329-10		
			(Continued)		

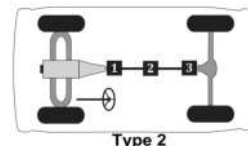
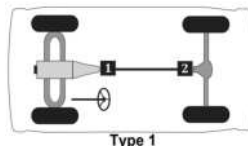

Passenger cars, light & medium trucks

Chevrolet/GMC Truck Full Size Vans, 1/2 ton van, 3/4 ton van, 1 ton van -- (Cont.)

MFG./YEAR	MODEL & LOCATION	PART NO.	MFG./YEAR	MODEL & LOCATION	PART NO.
Drive Shaft (2 W/D) (Cont.)			Drive Shaft (2 W/D) (Cont.)		
U-Joint (Cont.)			U-Joint (Cont.)		
1972-1961 P10 & P15 w/ 2 Joint Shaft w/o HD 3 Spd. & 4 Spd. Man. Trans.: [Type 1]			1971-1964 G10 & G15 w/ 2 Joint Shaft: [Type 1]		
U-Joint (Front)⊙		UJ369	U-Joint (Front)⊙		UJ369
Brute Force Greaseable		UJ280	Brute Force Greaseable		UJ280
Brute Force Non Greaseable		UJ269	Brute Force Non Greaseable		UJ269
(For Aluminum Drive Shaft)		UJ369C	(For Aluminum Drive Shaft)		UJ369C
U-Bolt Kit (Front)		UJ329-10	U-Bolt Kit (Front)		UJ329-10
U-Joint (Rear)⊙		UJ369	U-Joint (Rear)⊙		UJ369
Brute Force Greaseable		UJ280	Brute Force Greaseable		UJ280
Brute Force Non Greaseable		UJ269	Brute Force Non Greaseable		UJ269
(For Aluminum Drive Shaft)		UJ369C	(For Aluminum Drive Shaft)		UJ369C
U-Bolt Kit (Rear)		UJ329-10	U-Bolt Kit (Rear)		UJ329-10
1972-1961 P10 & P15 w/ 3 Joint Shaft, HD 3 Spd. & 4 Spd. Man. Trans.: [Type 2]			1971-1964 G10 & G15 w/ 3 Joint Shaft: [Type 2]		
U-Joint (Front)⊙		UJ331	U-Joint (Front)⊙		UJ369
Brute Force Greaseable		UJ232	Brute Force Greaseable		UJ280
Brute Force Non Greaseable		UJ231	Brute Force Non Greaseable		UJ269
(For Aluminum Drive Shaft)		UJ331C	(For Aluminum Drive Shaft)		UJ369C
U-Bolt Kit (Front)		UJ329-10	U-Bolt Kit (Front)		UJ329-10
U-Joint (Center)⊙		UJ369	U-Joint (Center)⊙		UJ369
Brute Force Greaseable		UJ280	Brute Force Greaseable		UJ280
Brute Force Non Greaseable		UJ269	Brute Force Non Greaseable		UJ269
(For Aluminum Drive Shaft)		UJ369C	(For Aluminum Drive Shaft)		UJ369C
U-Bolt Kit (Center)		UJ329-10	U-Bolt Kit (Center)		UJ329-10
U-Joint (Rear)⊙		UJ369	U-Joint (Rear)⊙		UJ369
Brute Force Greaseable		UJ280	Brute Force Greaseable		UJ280
Brute Force Non Greaseable		UJ269	Brute Force Non Greaseable		UJ269
(For Aluminum Drive Shaft)		UJ369C	(For Aluminum Drive Shaft)		UJ369C
U-Bolt Kit (Rear)		UJ329-10	U-Bolt Kit (Rear)		UJ329-10
1972-1961 P10 & P15 w/ 3 Joint Shaft w/o HD 3 Spd. & 4 Spd. Man. Trans.: [Type 2]			Drive Shaft (AWD)		
U-Joint (Front)⊙		UJ369	U-Joint		
Brute Force Greaseable		UJ280	2014-2003 Express 1500 & Savana 1500 w/ AWD:		
Brute Force Non Greaseable		UJ269	[Type 13]		
(For Aluminum Drive Shaft)		UJ369C	U-Joint (Fr. Shaft; Frt.)⊙		UJ534G
U-Bolt Kit (Front)		UJ329-10	Brute Force Greaseable		UJ235
U-Joint (Center)⊙		UJ369	Brute Force Non Greaseable		UJ234
Brute Force Greaseable		UJ280	Clamp Kit (Fr. Shaft; Frt.)		UJ530-10
Brute Force Non Greaseable		UJ269	U-Joint (Fr. Shaft; Rr.)⊙		UJ534G
(For Aluminum Drive Shaft)		UJ369C	Brute Force Greaseable		UJ235
U-Bolt Kit (Center)		UJ329-10	Brute Force Non Greaseable		UJ234
U-Joint (Rear)⊙		UJ369	Clamp Kit (Fr. Shaft; Rr.)		UJ530-10
Brute Force Greaseable		UJ280	U-Joint (Rr. Shaft; Frt.)⊙		UJ331
Brute Force Non Greaseable		UJ269	Brute Force Greaseable		UJ232
(For Aluminum Drive Shaft)		UJ369C	Brute Force Non Greaseable		UJ231
U-Bolt Kit (Rear)		UJ329-10	(For Aluminum Drive Shaft)		UJ331C
			U-Joint (Rr. Shaft; Rr.)⊙		UJ331
			Brute Force Greaseable		UJ232
			Brute Force Non Greaseable		UJ231
			(For Aluminum Drive Shaft)		UJ331C
			U-Joint (Rr. Shaft; Rr.)⊙		UJ331
			Brute Force Greaseable		UJ232
			Brute Force Non Greaseable		UJ231
			(For Aluminum Drive Shaft)		UJ331C

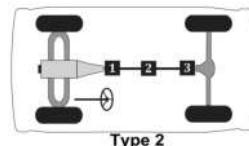
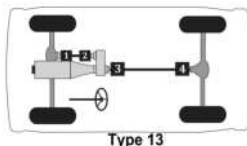
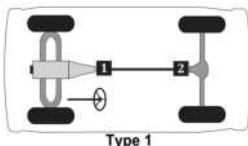

MFG./YEAR	MODEL & LOCATION	PART NO.	MFG./YEAR	MODEL & LOCATION	PART NO.
Drive Shaft (2 W/D)			Drive Shaft (2 W/D) (Cont.)		
U-Joint			U-Joint (Cont.)		
2020-2015 Suburban & Yukon XL: [Type 1]			2013-2008 Silverado & Sierra w/ 3 Joint Shaft:		
			[Type 2]		
	U-Joint (Front)Ⓢ	UJ330		U-Joint (Front)Ⓢ	UJ331A
	<i>Brute Force Greaseable</i>	UJ295		<i>Brute Force Greaseable</i>	UJ232A
	(For Aluminum Drive Shaft)	UJ330C		Clamp Kit (Front)	UJ492-10
	U-Joint (Rear)Ⓢ	UJ330		U-Joint (Center)Ⓢ	UJ331A
	<i>Brute Force Greaseable</i>	UJ295		<i>Brute Force Greaseable</i>	UJ232A
	(For Aluminum Drive Shaft)	UJ330C		Clamp Kit (Center)	UJ492-10
	2020-2014 Silverado & Sierra w/ 8 Cyl. Eng.:			U-Joint (Rear)Ⓢ	UJ331A
	[Type 1]			<i>Brute Force Greaseable</i>	UJ232A
	U-Joint (Front)Ⓢ	UJ330		Clamp Kit (Rear)	UJ492-10
	<i>Brute Force Greaseable</i>	UJ295		2008 Tahoe & Yukon w/ Hybrid Eng.: [Type 1]	
	(For Aluminum Drive Shaft)	UJ330C		U-Joint (Front)Ⓢ	UJ331A
	U-Joint (Rear)Ⓢ	UJ330		<i>Brute Force Greaseable</i>	UJ232A
	<i>Brute Force Greaseable</i>	UJ295		Clamp Kit (Rear)	UJ492-10
	(For Aluminum Drive Shaft)	UJ330C		2008 Tahoe & Yukon w/o Hybrid Eng.:	
	2018-2015 Tahoe & Yukon Exc. XL: [Type 1]			[Type 1]	
	U-Joint (Front)Ⓢ	UJ331		U-Joint (Front)Ⓢ	UJ534G
	<i>Brute Force Greaseable</i>	UJ232		<i>Brute Force Greaseable</i>	UJ235
	<i>Brute Force Non Greaseable</i>	UJ231		<i>Brute Force Non Greaseable</i>	UJ234
	(For Aluminum Drive Shaft)	UJ331C		Clamp Kit (Front)	UJ530-10
	U-Joint (Rear)Ⓢ	UJ331		U-Joint (Rear)Ⓢ	UJ534G
	<i>Brute Force Greaseable</i>	UJ232		<i>Brute Force Greaseable</i>	UJ235
	<i>Brute Force Non Greaseable</i>	UJ231		<i>Brute Force Non Greaseable</i>	UJ234
	(For Aluminum Drive Shaft)	UJ331C		Clamp Kit (Rear)	UJ530-10
	2018-2014 Silverado & Sierra w/ 6 Cyl. Eng.:			2008-2007 Avalanche, Suburban & Yukon XL w/ 5.3L Eng.: [Type 1]	
	[Type 1]			U-Joint (Front)Ⓢ	UJ534G
	U-Joint (Front)Ⓢ	UJ534G		<i>Brute Force Greaseable</i>	UJ235
	<i>Brute Force Greaseable</i>	UJ235		<i>Brute Force Non Greaseable</i>	UJ234
	<i>Brute Force Non Greaseable</i>	UJ234		Clamp Kit (Front)	UJ530-10
	U-Joint (Rear)Ⓢ	UJ534G		U-Joint (Rear)Ⓢ	UJ534G
	<i>Brute Force Greaseable</i>	UJ235		<i>Brute Force Greaseable</i>	UJ235
	<i>Brute Force Non Greaseable</i>	UJ234		<i>Brute Force Non Greaseable</i>	UJ234
	2014-2009 Avalanche, Suburban, Tahoe & Yukon: [Type 1]			Clamp Kit (Rear)	UJ530-10
	U-Joint (Front)Ⓢ	UJ331A		2008-2007 Avalanche, Suburban & Yukon XL w/ 6.0L Eng.: [Type 1]	
	<i>Brute Force Greaseable</i>	UJ232A		U-Joint (Front)Ⓢ	UJ331A
	Clamp Kit (Front)	UJ492-10		<i>Brute Force Greaseable</i>	UJ232A
	U-Joint (Rear)Ⓢ	UJ331A		Clamp Kit (Front)	UJ492-10
	<i>Brute Force Greaseable</i>	UJ232A		U-Joint (Rear)Ⓢ	UJ331A
	Clamp Kit (Rear)	UJ492-10		<i>Brute Force Greaseable</i>	UJ232A
	2013-2008 Silverado & Sierra w/ 2 Joint Shaft:			Clamp Kit (Rear)	UJ492-10
	[Type 1]				(Continued)
	U-Joint (Front)Ⓢ	UJ331A			
	<i>Brute Force Greaseable</i>	UJ232A			
	Clamp Kit (Front)	UJ492-10			
	U-Joint (Rear)Ⓢ	UJ331A			
	<i>Brute Force Greaseable</i>	UJ232A			
	Clamp Kit (Rear)	UJ492-10			

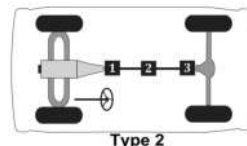
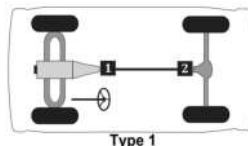

Passenger cars, light & medium trucks

Chevrolet/GMC Truck 1/2 ton -- (Cont.)

MFG./YEAR	MODEL & LOCATION	PART NO.	MFG./YEAR	MODEL & LOCATION	PART NO.
Drive Shaft (2 W/D) (Cont.)			Drive Shaft (2 W/D) (Cont.)		
U-Joint (Cont.)			U-Joint (Cont.)		
2007	Silverado & Sierra Exc. Classic w/ 2 Joint Shaft: [Type 1]		2007	Silverado & Sierra Classic Exc. HD w/ Ext. Cab, Long Bed & Auto. Trans.: [Type 2]	
	U-Joint (Front)Ⓛ	UJ331A		U-Joint (Front)Ⓛ	UJ534G
	Brute Force Greaseable	UJ232A		Brute Force Greaseable	UJ235
	Clamp Kit (Front)	UJ492-10		Brute Force Non Greaseable	UJ234
	U-Joint (Rear)Ⓛ	UJ331A		Clamp Kit (Front)	UJ530-10
	Brute Force Greaseable	UJ232A		U-Joint (Center)Ⓛ	UJ534G
	Clamp Kit (Rear)	UJ492-10		Brute Force Greaseable	UJ235
2007	Silverado & Sierra Exc. Classic w/ 3 Joint Shaft: [Type 2]			Brute Force Non Greaseable	UJ234
	U-Joint (Front)Ⓛ	UJ331A		Clamp Kit (Center)	UJ530-10
	Brute Force Greaseable	UJ232A		U-Joint (Rear)Ⓛ	UJ534G
	Clamp Kit (Front)	UJ492-10		Brute Force Greaseable	UJ235
	U-Joint (Center)Ⓛ	UJ331A		Brute Force Non Greaseable	UJ234
	Brute Force Greaseable	UJ232A		Clamp Kit (Rear)	UJ530-10
	Clamp Kit (Center)	UJ492-10	2007	Silverado & Sierra Classic Exc. HD w/ Ext. Cab, Long Bed & Man. Trans.: [Type 2]	
	U-Joint (Rear)Ⓛ	UJ331A		U-Joint (Front)Ⓛ	UJ354
	Brute Force Greaseable	UJ232A		Brute Force Greaseable	UJ270
	Clamp Kit (Rear)	UJ492-10		Brute Force Non Greaseable	UJ254
2007	Silverado & Sierra Classic Exc. HD w/ Reg. Cab & Long Bed: [Type 1]			(For Aluminum Drive Shaft)	UJ354C
	U-Joint (Front)Ⓛ	UJ354		U-Joint (Center)Ⓛ	UJ354
	Brute Force Greaseable	UJ270		Brute Force Greaseable	UJ270
	Brute Force Non Greaseable	UJ254		Brute Force Non Greaseable	UJ254
	(For Aluminum Drive Shaft)	UJ354C		(For Aluminum Drive Shaft)	UJ354C
	U-Joint (Rear)Ⓛ	UJ355		U-Joint (Rear)Ⓛ	UJ355
	Brute Force Greaseable	UJ290		Brute Force Greaseable	UJ290
	(For Aluminum Drive Shaft)	UJ355C		(For Aluminum Drive Shaft)	UJ355C
	Clamp Kit (Rear)	UJ530-10	2007	Silverado & Sierra Classic Exc. HD w/ Crew Cab: [Type 1]	
2007	Silverado & Sierra Classic Exc. HD w/ Reg. Cab & Standard Bed: [Type 1]			U-Joint (Front)Ⓛ	UJ354
	U-Joint (Front)Ⓛ	UJ534G		Brute Force Greaseable	UJ270
	Brute Force Greaseable	UJ235		Brute Force Non Greaseable	UJ254
	Brute Force Non Greaseable	UJ234		(For Aluminum Drive Shaft)	UJ354C
	Clamp Kit (Front)	UJ530-10		U-Joint (Rear)Ⓛ	UJ355
	U-Joint (Rear)Ⓛ	UJ534G		Brute Force Greaseable	UJ290
	Brute Force Greaseable	UJ235		(For Aluminum Drive Shaft)	UJ355C
	Brute Force Non Greaseable	UJ234		Clamp Kit (Rear)	UJ530-10
	Clamp Kit (Rear)	UJ530-10			(Continued)
2007	Silverado & Sierra Classic Exc. HD w/ Ext. Cab & Short Bed: [Type 1]				
	U-Joint (Front)Ⓛ	UJ534G			
	Brute Force Greaseable	UJ235			
	Brute Force Non Greaseable	UJ234			
	Clamp Kit (Front)	UJ530-10			
	U-Joint (Rear)Ⓛ	UJ534G			
	Brute Force Greaseable	UJ235			
	Brute Force Non Greaseable	UJ234			
	Clamp Kit (Rear)	UJ530-10			

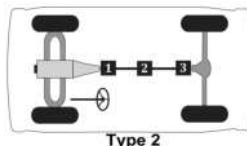
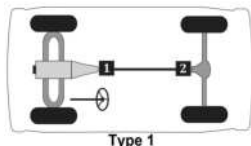

Passenger cars, light & medium trucks

(Cont.) -- Chevrolet/GMC Truck 1/2 ton

MFG./YEAR	MODEL & LOCATION	PART NO.	MFG./YEAR	MODEL & LOCATION	PART NO.
Drive Shaft (2 W/D) (Cont.)			Drive Shaft (2 W/D) (Cont.)		
U-Joint (Cont.)			U-Joint (Cont.)		
2007	Silverado & Sierra Classic & HD: [Type 2]		2006	Silverado & Sierra HD: [Type 2]	
	U-Joint (Front)ⓐ	UJ331		U-Joint (Front)ⓐ	UJ331
	Brute Force Greaseable	UJ232		Brute Force Greaseable	UJ232
	Brute Force Non Greaseable	UJ231		Brute Force Non Greaseable	UJ231
	(For Aluminum Drive Shaft)	UJ331C		(For Aluminum Drive Shaft)	UJ331C
	Clamp Kit (Front)	UJ492-10		Clamp Kit (Front)	UJ492-10
	U-Joint (Center)ⓑ	UJ331		U-Joint (Center)ⓑ	UJ331
	Brute Force Greaseable	UJ232		Brute Force Greaseable	UJ232
	Brute Force Non Greaseable	UJ231		Brute Force Non Greaseable	UJ231
	(For Aluminum Drive Shaft)	UJ331C		(For Aluminum Drive Shaft)	UJ331C
	Clamp Kit (Center)	UJ492-10		Clamp Kit (Center)	UJ492-10
	U-Joint (Rear)ⓐ	UJ331		U-Joint (Rear)ⓐ	UJ331
	Brute Force Greaseable	UJ232		Brute Force Greaseable	UJ232
	Brute Force Non Greaseable	UJ231		Brute Force Non Greaseable	UJ231
	(For Aluminum Drive Shaft)	UJ331C		(For Aluminum Drive Shaft)	UJ331C
	Clamp Kit (Rear)	UJ492-10		Clamp Kit (Rear)	UJ492-10
2007-1992	Tahoe & Yukon Exc. XL: [Type 1]		2006	Silverado SS: [Type 2]	
	U-Joint (Front)ⓐ	UJ534G		U-Joint (Front)ⓐ	UJ331A
	Brute Force Greaseable	UJ235		Brute Force Greaseable	UJ232A
	Brute Force Non Greaseable	UJ234		Clamp Kit (Front)	UJ492-10
	Clamp Kit (Front)	UJ530-10		U-Joint (Center)ⓑ	UJ331A
	U-Joint (Rear)ⓐ	UJ534G		Brute Force Greaseable	UJ232A
	Brute Force Greaseable	UJ235		Clamp Kit (Center)	UJ492-10
	Brute Force Non Greaseable	UJ234		U-Joint (Rear)ⓐ	UJ331A
	Clamp Kit (Rear)	UJ530-10		Brute Force Greaseable	UJ232A
2006	Silverado & Sierra Exc. HD & SS w/ Crew Cab & QuadraSteer: [Type 1]		2006-2005	Silverado & Sierra Exc. HD & SS w/ Ext. Cab & Auto. Trans.: [Type 2]	
	U-Joint (Front)ⓐ	UJ331		U-Joint (Front)ⓐ	UJ534G
	Brute Force Greaseable	UJ232		Brute Force Greaseable	UJ235
	Brute Force Non Greaseable	UJ231		Brute Force Non Greaseable	UJ234
	(For Aluminum Drive Shaft)	UJ331C		Clamp Kit (Front)	UJ530-10
	Clamp Kit (Front)	UJ492-10		U-Joint (Center)ⓑ	UJ534G
	U-Joint (Rear)ⓐ	UJ331		Brute Force Greaseable	UJ235
	Brute Force Greaseable	UJ232		Brute Force Non Greaseable	UJ234
	Brute Force Non Greaseable	UJ231		Clamp Kit (Center)	UJ530-10
	(For Aluminum Drive Shaft)	UJ331C		U-Joint (Rear)ⓐ	UJ534G
	Clamp Kit (Rear)	UJ492-10		Brute Force Greaseable	UJ235
2006	Silverado & Sierra Exc. HD & SS w/ Crew Cab w/o QuadraSteer: [Type 1]			Brute Force Non Greaseable	UJ234
	U-Joint (Front)ⓐ	UJ354		Clamp Kit (Rear)	UJ530-10
	Brute Force Greaseable	UJ270			
	Brute Force Non Greaseable	UJ254			
	(For Aluminum Drive Shaft)	UJ354C			
	U-Joint (Rear)ⓐ	UJ355			
	Brute Force Greaseable	UJ290			
	(For Aluminum Drive Shaft)	UJ355C			

(Continued)

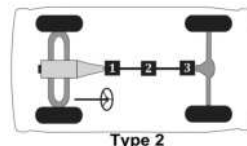
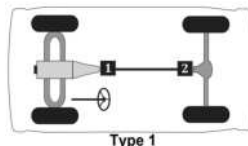

Passenger cars, light & medium trucks

Chevrolet/GMC Truck 1/2 ton -- (Cont.)

MFG./YEAR	MODEL & LOCATION	PART NO.	MFG./YEAR	MODEL & LOCATION	PART NO.
-----------	------------------	----------	-----------	------------------	----------

Drive Shaft (2 W/D) (Cont.)

U-Joint (Cont.)

2006-2005 Silverado & Sierra Exc. HD & SS w/	
Ext. Cab & Man. Trans.: [Type 2]	
U-Joint (Front)Ⓛ	UJ354
<i>Brute Force Greaseable</i>	<i>UJ270</i>
<i>Brute Force Non Greaseable</i>	<i>UJ254</i>
(For Aluminum Drive Shaft)	UJ354C
U-Joint (Center)Ⓢ	UJ354
<i>Brute Force Greaseable</i>	<i>UJ270</i>
<i>Brute Force Non Greaseable</i>	<i>UJ254</i>
(For Aluminum Drive Shaft)	UJ354C
U-Joint (Rear)Ⓢ	UJ355
<i>Brute Force Greaseable</i>	<i>UJ290</i>
(For Aluminum Drive Shaft)	UJ355C
Clamp Kit (Rear)	UJ530-10
2006-2004 Silverado & Sierra Exc. HD & SS w/	
Reg. Cab & Long Bed: [Type 1]	
U-Joint (Front)Ⓛ	UJ354
<i>Brute Force Greaseable</i>	<i>UJ270</i>
<i>Brute Force Non Greaseable</i>	<i>UJ254</i>
(For Aluminum Drive Shaft)	UJ354C
U-Joint (Rear)Ⓢ	UJ355
<i>Brute Force Greaseable</i>	<i>UJ290</i>
(For Aluminum Drive Shaft)	UJ355C
Clamp Kit (Rear)	UJ530-10
2006-2004 Silverado & Sierra Exc. HD & SS w/	
Reg. Cab & Standard Bed: [Type 1]	
U-Joint (Front)Ⓛ	UJ534G
<i>Brute Force Greaseable</i>	<i>UJ235</i>
<i>Brute Force Non Greaseable</i>	<i>UJ234</i>
Clamp Kit (Front)	UJ530-10
U-Joint (Rear)Ⓢ	UJ534G
<i>Brute Force Greaseable</i>	<i>UJ235</i>
<i>Brute Force Non Greaseable</i>	<i>UJ234</i>
Clamp Kit (Rear)	UJ530-10
2006-2000 Avalanche, Suburban & Yukon XL:	
[Type 1]	
U-Joint (Front)Ⓛ	UJ354
<i>Brute Force Greaseable</i>	<i>UJ270</i>
<i>Brute Force Non Greaseable</i>	<i>UJ254</i>
(For Aluminum Drive Shaft)	UJ354C
U-Joint (Rear)Ⓢ	UJ355
<i>Brute Force Greaseable</i>	<i>UJ290</i>
(For Aluminum Drive Shaft)	UJ355C
Clamp Kit (Rear)	UJ530-10

Drive Shaft (2 W/D) (Cont.)

U-Joint (Cont.)

2005 Silverado & Sierra HD & SS: [Type 2]	
U-Joint (Front)Ⓛ	UJ331
<i>Brute Force Greaseable</i>	<i>UJ232</i>
<i>Brute Force Non Greaseable</i>	<i>UJ231</i>
(For Aluminum Drive Shaft)	UJ331C
Clamp Kit (Front)	UJ492-10
U-Joint (Center)Ⓢ	UJ331
<i>Brute Force Greaseable</i>	<i>UJ232</i>
<i>Brute Force Non Greaseable</i>	<i>UJ231</i>
(For Aluminum Drive Shaft)	UJ331C
Clamp Kit (Center)	UJ492-10
U-Joint (Rear)Ⓢ	UJ331
<i>Brute Force Greaseable</i>	<i>UJ232</i>
<i>Brute Force Non Greaseable</i>	<i>UJ231</i>
(For Aluminum Drive Shaft)	UJ331C
Clamp Kit (Rear)	UJ492-10
2005-2004 Silverado & Sierra Exc. HD & SS w/	
Crew Cab: [Type 1]	
U-Joint (Front)Ⓛ	UJ354
<i>Brute Force Greaseable</i>	<i>UJ270</i>
<i>Brute Force Non Greaseable</i>	<i>UJ254</i>
(For Aluminum Drive Shaft)	UJ354C
U-Joint (Rear)Ⓢ	UJ355
<i>Brute Force Greaseable</i>	<i>UJ290</i>
(For Aluminum Drive Shaft)	UJ355C
Clamp Kit (Rear)	UJ530-10
2004-2002 Silverado & Sierra w/ Ext. Cab & Auto.	
Trans. w/o QuadraSteer: [Type 2]	
U-Joint (Front)Ⓛ	UJ534G
<i>Brute Force Greaseable</i>	<i>UJ235</i>
<i>Brute Force Non Greaseable</i>	<i>UJ234</i>
Clamp Kit (Front)	UJ530-10
U-Joint (Center)Ⓢ	UJ534G
<i>Brute Force Greaseable</i>	<i>UJ235</i>
<i>Brute Force Non Greaseable</i>	<i>UJ234</i>
Clamp Kit (Center)	UJ530-10
U-Joint (Rear)Ⓢ	UJ534G
<i>Brute Force Greaseable</i>	<i>UJ235</i>
<i>Brute Force Non Greaseable</i>	<i>UJ234</i>
Clamp Kit (Rear)	UJ530-10

(Continued)

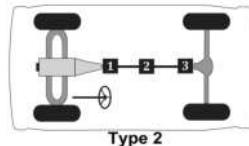
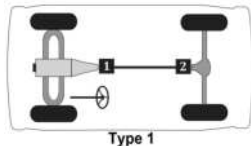

Passenger cars, light & medium trucks

(Cont.) -- Chevrolet/GMC Truck 1/2 ton

MFG./YEAR	MODEL & LOCATION	PART NO.	MFG./YEAR	MODEL & LOCATION	PART NO.
Drive Shaft (2 W/D) (Cont.)			Drive Shaft (2 W/D) (Cont.)		
U-Joint (Cont.)			U-Joint (Cont.)		
2004-2002 Silverado & Sierra w/ Ext. Cab & Man. Trans. w/o QuadraSteer: [Type 2]			2003-1996 C1500, Silverado & Sierra w/ Reg. Cab & Short Bed: [Type 1]		
U-Joint (Front)Ⓢ		UJ354	U-Joint (Front)Ⓢ		UJ534G
Brute Force Greaseable		UJ270	Brute Force Greaseable		UJ235
Brute Force Non Greaseable		UJ254	Brute Force Non Greaseable		UJ234
(For Aluminum Drive Shaft)		UJ354C	Clamp Kit (Front)		UJ530-10
U-Joint (Center)Ⓢ		UJ354	U-Joint (Rear)Ⓢ		UJ534G
Brute Force Greaseable		UJ270	Brute Force Greaseable		UJ235
Brute Force Non Greaseable		UJ254	Brute Force Non Greaseable		UJ234
(For Aluminum Drive Shaft)		UJ354C	Clamp Kit (Rear)		UJ530-10
U-Joint (Rear)Ⓢ		UJ355	2003-1996 C1500, Silverado & Sierra w/ Reg. Cab & Long Bed: [Type 1]		
Brute Force Greaseable		UJ290	U-Joint (Front)Ⓢ		UJ354
(For Aluminum Drive Shaft)		UJ355C	Brute Force Greaseable		UJ270
Clamp Kit (Rear)		UJ530-10	Brute Force Non Greaseable		UJ254
2004-2002 Silverado & Sierra w/ Ext. Cab & QuadraSteer: [Type 2]			(For Aluminum Drive Shaft)		UJ354C
U-Joint (Front)Ⓢ		UJ534G	U-Joint (Rear)Ⓢ		UJ355
Brute Force Greaseable		UJ235	Brute Force Greaseable		UJ290
Brute Force Non Greaseable		UJ234	(For Aluminum Drive Shaft)		UJ355C
Clamp Kit (Front)		UJ530-10	Clamp Kit (Rear)		UJ530-10
U-Joint (Center)Ⓢ		UJ534G	2001 Silverado & Sierra w/ Ext. Cab & Man. Trans.: [Type 2]		
Brute Force Greaseable		UJ235	U-Joint (Front)Ⓢ		UJ354
Brute Force Non Greaseable		UJ234	Brute Force Greaseable		UJ270
Clamp Kit (Center)		UJ530-10	Brute Force Non Greaseable		UJ254
U-Joint (Rear)Ⓢ		UJ331	(For Aluminum Drive Shaft)		UJ354C
Brute Force Greaseable		UJ232	U-Joint (Center)Ⓢ		UJ354
Brute Force Non Greaseable		UJ231	Brute Force Greaseable		UJ270
(For Aluminum Drive Shaft)		UJ331C	Brute Force Non Greaseable		UJ254
Clamp Kit (Rear)		UJ492-10	(For Aluminum Drive Shaft)		UJ354C
2003-2001 Silverado & Sierra Crew Cab: [Type 2]			U-Joint (Rear)Ⓢ		UJ355
U-Joint (Front)Ⓢ		UJ331	Brute Force Greaseable		UJ290
Brute Force Greaseable		UJ232	(For Aluminum Drive Shaft)		UJ355C
Brute Force Non Greaseable		UJ231	Clamp Kit (Rear)		UJ530-10
(For Aluminum Drive Shaft)		UJ331C	2001-1999 C1500, Silverado & Sierra w/ Ext. Cab & Auto. Trans.: [Type 2]		
Clamp Kit (Front)		UJ492-10	U-Joint (Front)Ⓢ		UJ534G
U-Joint (Center)Ⓢ		UJ331	Brute Force Greaseable		UJ235
Brute Force Greaseable		UJ232	Brute Force Non Greaseable		UJ234
Brute Force Non Greaseable		UJ231	Clamp Kit (Front)		UJ530-10
(For Aluminum Drive Shaft)		UJ331C	U-Joint (Center)Ⓢ		UJ534G
Clamp Kit (Center)		UJ492-10	Brute Force Greaseable		UJ235
U-Joint (Rear)Ⓢ		UJ331	Brute Force Non Greaseable		UJ234
Brute Force Greaseable		UJ232	Clamp Kit (Center)		UJ530-10
Brute Force Non Greaseable		UJ231	U-Joint (Rear)Ⓢ		UJ534G
(For Aluminum Drive Shaft)		UJ331C	Brute Force Greaseable		UJ235
Clamp Kit (Rear)		UJ492-10	Brute Force Non Greaseable		UJ234
			Clamp Kit (Rear)		UJ530-10

(Continued)

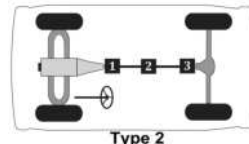
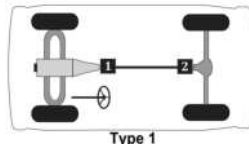

Passenger cars, light & medium trucks

Chevrolet/GMC Truck 1/2 ton -- (Cont.)

MFG./YEAR	MODEL & LOCATION	PART NO.	MFG./YEAR	MODEL & LOCATION	PART NO.
-----------	------------------	----------	-----------	------------------	----------

Drive Shaft (2 W/D) (Cont.)

U-Joint (Cont.)

2000-1999 C1500, Silverado & Sierra w/ Ext. Cab,
Short Bed & Man. Trans.: [Type 1]

U-Joint (Front)Ⓛ	UJ354
Brute Force Greaseable	UJ270
Brute Force Non Greaseable	UJ254
(For Aluminum Drive Shaft)	UJ354C
U-Joint (Rear)Ⓛ	UJ355
Brute Force Greaseable	UJ290
(For Aluminum Drive Shaft)	UJ355C
Clamp Kit (Rear)	UJ530-10

2000-1999 C1500, Silverado & Sierra w/ Ext. Cab,
Long Bed & Man. Trans.: [Type 2]

U-Joint (Front)Ⓛ	UJ354
Brute Force Greaseable	UJ270
Brute Force Non Greaseable	UJ254
(For Aluminum Drive Shaft)	UJ354C
U-Joint (Center)Ⓛ	UJ354
Brute Force Greaseable	UJ270
Brute Force Non Greaseable	UJ254
(For Aluminum Drive Shaft)	UJ354C
U-Joint (Rear)Ⓛ	UJ355
Brute Force Greaseable	UJ290
(For Aluminum Drive Shaft)	UJ355C
Clamp Kit (Rear)	UJ530-10

1999-1996 Suburban w/ 6.5L Eng.: [Type 1]

U-Joint (Front)Ⓛ	UJ331
Brute Force Greaseable	UJ232
Brute Force Non Greaseable	UJ231
(For Aluminum Drive Shaft)	UJ331C
Clamp Kit (Front)	UJ492-10
U-Joint (Rear)Ⓛ	UJ331
Brute Force Greaseable	UJ232
Brute Force Non Greaseable	UJ231
(For Aluminum Drive Shaft)	UJ331C
Clamp Kit (Rear)	UJ492-10

1999-1996 Suburban w/ 5.7L Eng.: [Type 1]

U-Joint (Front)Ⓛ	UJ354
Brute Force Greaseable	UJ270
Brute Force Non Greaseable	UJ254
(For Aluminum Drive Shaft)	UJ354C
U-Joint (Rear)Ⓛ	UJ355
Brute Force Greaseable	UJ290
(For Aluminum Drive Shaft)	UJ355C
Clamp Kit (Rear)	UJ530-10

Drive Shaft (2 W/D) (Cont.)

U-Joint (Cont.)

1998-1996 C1500 w/ Ext. Cab: [Type 2]

U-Joint (Front)Ⓛ	UJ354
Brute Force Greaseable	UJ270
Brute Force Non Greaseable	UJ254
(For Aluminum Drive Shaft)	UJ354C
U-Joint (Center)Ⓛ	UJ354
Brute Force Greaseable	UJ270
Brute Force Non Greaseable	UJ254
(For Aluminum Drive Shaft)	UJ354C
U-Joint (Rear)Ⓛ	UJ354
Brute Force Greaseable	UJ270
Brute Force Non Greaseable	UJ254
(For Aluminum Drive Shaft)	UJ354C

1996 C1500 w/ Reg. Cab & Short Bed:

[Type 1]

U-Joint (Front)Ⓛ	UJ534G
Brute Force Greaseable	UJ235
Brute Force Non Greaseable	UJ234
Clamp Kit (Front)	UJ530-10
U-Joint (Rear)Ⓛ	UJ534G
Brute Force Greaseable	UJ235
Brute Force Non Greaseable	UJ234
Clamp Kit (Rear)	UJ530-10

1995 C1500 w/ Gas Eng., Reg. Cab, Long
Bed & MW3 Man. Trans.: [Type 2]

U-Joint (Front)Ⓛ	UJ331
Brute Force Greaseable	UJ232
Brute Force Non Greaseable	UJ231
(For Aluminum Drive Shaft)	UJ331C
Clamp Kit (Front)	UJ492-10
U-Joint (Center)Ⓛ	UJ331
Brute Force Greaseable	UJ232
Brute Force Non Greaseable	UJ231
(For Aluminum Drive Shaft)	UJ331C
U-Joint (Rear)Ⓛ	UJ331
Brute Force Greaseable	UJ232
Brute Force Non Greaseable	UJ231
(For Aluminum Drive Shaft)	UJ331C
Clamp Kit (Rear)	UJ492-10

1995 C1500 w/ Gas Eng., Reg. Cab, Long
Bed w/o MW3 Man. Trans.: [Type 1]

U-Joint (Front)Ⓛ	UJ354
Brute Force Greaseable	UJ270
Brute Force Non Greaseable	UJ254
(For Aluminum Drive Shaft)	UJ354C
U-Joint (Rear)Ⓛ	UJ355
Brute Force Greaseable	UJ290
(For Aluminum Drive Shaft)	UJ355C

(Continued)

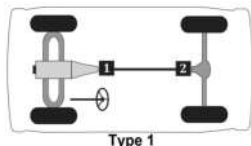

Type 1

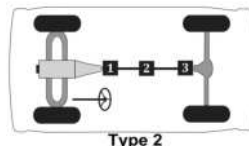

Type 2

Passenger cars, light & medium trucks

(Cont.) -- Chevrolet/GMC Truck 1/2 ton

MFG./YEAR	MODEL & LOCATION	PART NO.	MFG./YEAR	MODEL & LOCATION	PART NO.
Drive Shaft (2 W/D) (Cont.)			Drive Shaft (2 W/D) (Cont.)		
U-Joint (Cont.)			U-Joint (Cont.)		
1995	C1500 w/ Gas Eng., Ext. Cab & MW3 Man. Trans.: [Type 2]		1995-1992 Suburban: [Type 1]		
	U-Joint (Front)Ⓢ	UJ331	U-Joint (Front)Ⓢ		UJ354
	Brute Force Greaseable	UJ232	Brute Force Greaseable		UJ270
	Brute Force Non Greaseable	UJ231	Brute Force Non Greaseable		UJ254
	(For Aluminum Drive Shaft)	UJ331C	(For Aluminum Drive Shaft)		UJ354C
	Clamp Kit (Front)	UJ492-10	U-Joint (Rear)Ⓢ		UJ355
	U-Joint (Center)Ⓢ	UJ331	Brute Force Greaseable		UJ290
	Brute Force Greaseable	UJ232	(For Aluminum Drive Shaft)		UJ355C
	Brute Force Non Greaseable	UJ231	Clamp Kit (Rear)		UJ530-10
	(For Aluminum Drive Shaft)	UJ331C	1994 C1500 w/ Gas Eng., Reg. Cab, Long Bed & MT8 Man. Trans.: [Type 2]		
	Clamp Kit (Center)	UJ492-10	U-Joint (Front)Ⓢ		UJ331
	U-Joint (Rear)Ⓢ	UJ331	Brute Force Greaseable		UJ232
	Brute Force Greaseable	UJ232	Brute Force Non Greaseable		UJ231
	Brute Force Non Greaseable	UJ231	(For Aluminum Drive Shaft)		UJ331C
	(For Aluminum Drive Shaft)	UJ331C	Clamp Kit (Front)		UJ492-10
	Clamp Kit (Rear)	UJ492-10	U-Joint (Center)Ⓢ		UJ331
1995	C1500 w/ Gas Eng., Ext. Cab w/o MW3 Man. Trans.: [Type 2]		Brute Force Greaseable		UJ232
	U-Joint (Front)Ⓢ	UJ354	Brute Force Non Greaseable		UJ231
	Brute Force Greaseable	UJ270	(For Aluminum Drive Shaft)		UJ331C
	Brute Force Non Greaseable	UJ254	Clamp Kit (Center)		UJ492-10
	(For Aluminum Drive Shaft)	UJ354C	U-Joint (Rear)Ⓢ		UJ331
	U-Joint (Center)Ⓢ	UJ354	Brute Force Greaseable		UJ232
	Brute Force Greaseable	UJ270	Brute Force Non Greaseable		UJ231
	Brute Force Non Greaseable	UJ254	(For Aluminum Drive Shaft)		UJ331C
	(For Aluminum Drive Shaft)	UJ354C	Clamp Kit (Rear)		UJ492-10
	U-Joint (Rear)Ⓢ	UJ355	1994 C1500 w/ Gas Eng., Reg. Cab, Long Bed w/o MT8 Man. Trans.: [Type 1]		
	Brute Force Greaseable	UJ290	U-Joint (Front)Ⓢ		UJ354
	(For Aluminum Drive Shaft)	UJ355C	Brute Force Greaseable		UJ270
1995-1994	C1500 w/ Diesel Eng.: [Type 2]		Brute Force Non Greaseable		UJ254
	U-Joint (Front)Ⓢ	UJ354	(For Aluminum Drive Shaft)		UJ354C
	Brute Force Greaseable	UJ270	U-Joint (Rear)Ⓢ		UJ355
	Brute Force Non Greaseable	UJ254	Brute Force Greaseable		UJ290
	(For Aluminum Drive Shaft)	UJ354C	(For Aluminum Drive Shaft)		UJ355C
	U-Joint (Center)Ⓢ	UJ354	Clamp Kit (Rear)		UJ530-10
	Brute Force Greaseable	UJ270	1994 C1500 w/ Gas Eng., Ext. Cab, Auto. Trans. & Inner Lock Rings: [Type 2]		
	Brute Force Non Greaseable	UJ254	U-Joint (Front)Ⓢ		UJ534G
	(For Aluminum Drive Shaft)	UJ354C	Brute Force Greaseable		UJ235
	U-Joint (Rear)Ⓢ	UJ355	Brute Force Non Greaseable		UJ234
	Brute Force Greaseable	UJ290	Clamp Kit (Front)		UJ530-10
	(For Aluminum Drive Shaft)	UJ355C	U-Joint (Center)Ⓢ		UJ534G
1995-1994	C1500 w/ Gas Eng., Reg. Cab & Short Bed: [Type 1]		Brute Force Greaseable		UJ235
	U-Joint (Front)Ⓢ	UJ534G	Brute Force Non Greaseable		UJ234
	Brute Force Greaseable	UJ235	Clamp Kit (Center)		UJ530-10
	Brute Force Non Greaseable	UJ234	U-Joint (Rear)Ⓢ		UJ534G
	Clamp Kit (Front)	UJ530-10	Brute Force Greaseable		UJ235
	U-Joint (Rear)Ⓢ	UJ534G	Brute Force Non Greaseable		UJ234
	Brute Force Greaseable	UJ235	Clamp Kit (Rear)		UJ530-10
	Brute Force Non Greaseable	UJ234			
	Clamp Kit (Rear)	UJ530-10			

(Continued)

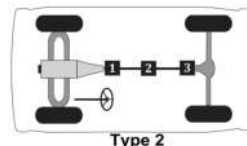
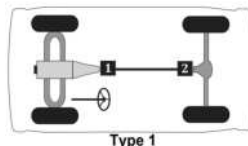

Passenger cars, light & medium trucks

Chevrolet/GMC Truck 1/2 ton -- (Cont.)

MFG./YEAR	MODEL & LOCATION	PART NO.	MFG./YEAR	MODEL & LOCATION	PART NO.
Drive Shaft (2 W/D) (Cont.)			Drive Shaft (2 W/D) (Cont.)		
U-Joint (Cont.)			U-Joint (Cont.)		
1994	C1500 w/ Gas Eng., Ext. Cab, Auto. Trans. & Outer Lock Rings: [Type 2]		1993-1992	C1500 w/ Ext. Cab & Auto. Trans.: [Type 2]	
	U-Joint (Front)Ⓛ	UJ354		U-Joint (Front)Ⓛ	UJ534G
	<i>Brute Force Greaseable</i>	UJ270		<i>Brute Force Greaseable</i>	UJ235
	<i>Brute Force Non Greaseable</i>	UJ254		<i>Brute Force Non Greaseable</i>	UJ234
	(For Aluminum Drive Shaft)	UJ354C		Clamp Kit (Front)	UJ530-10
	U-Joint (Center)Ⓢ	UJ354		U-Joint (Center)Ⓢ	UJ534G
	<i>Brute Force Greaseable</i>	UJ270		<i>Brute Force Greaseable</i>	UJ235
	<i>Brute Force Non Greaseable</i>	UJ254		<i>Brute Force Non Greaseable</i>	UJ234
	(For Aluminum Drive Shaft)	UJ354C		Clamp Kit (Center)	UJ530-10
	U-Joint (Rear)Ⓢ	UJ355		U-Joint (Rear)Ⓢ	UJ534G
	<i>Brute Force Greaseable</i>	UJ290		<i>Brute Force Greaseable</i>	UJ235
	(For Aluminum Drive Shaft)	UJ355C		<i>Brute Force Non Greaseable</i>	UJ234
	Clamp Kit (Rear)	UJ530-10		Clamp Kit (Rear)	UJ530-10
1994	C1500 w/ Gas Eng., Ext. Cab & MG5 Man. Trans.: [Type 2]		1993-1992	C1500 w/ Reg. Cab, Long Bed & MT8 Man. Trans.: [Type 2]	
	U-Joint (Front)Ⓛ	UJ354		U-Joint (Front)Ⓛ	UJ331
	<i>Brute Force Greaseable</i>	UJ270		<i>Brute Force Greaseable</i>	UJ232
	<i>Brute Force Non Greaseable</i>	UJ254		<i>Brute Force Non Greaseable</i>	UJ231
	(For Aluminum Drive Shaft)	UJ354C		(For Aluminum Drive Shaft)	UJ331C
	U-Joint (Center)Ⓢ	UJ354		Clamp Kit (Front)	UJ492-10
	<i>Brute Force Greaseable</i>	UJ270		U-Joint (Center)Ⓢ	UJ331
	<i>Brute Force Non Greaseable</i>	UJ254		<i>Brute Force Greaseable</i>	UJ232
	(For Aluminum Drive Shaft)	UJ354C		<i>Brute Force Non Greaseable</i>	UJ231
	U-Joint (Rear)Ⓢ	UJ355		(For Aluminum Drive Shaft)	UJ331C
	<i>Brute Force Greaseable</i>	UJ290		Clamp Kit (Center)	UJ492-10
	(For Aluminum Drive Shaft)	UJ355C		U-Joint (Rear)Ⓢ	UJ331
	Clamp Kit (Rear)	UJ530-10		<i>Brute Force Greaseable</i>	UJ232
1994	C1500 w/ Gas Eng., Ext. Cab & MT8 Man. Trans.: [Type 2]		1993-1992	C1500 w/ Reg. Cab & Long Bed w/o MT8 Man. Trans.: [Type 1]	
	U-Joint (Front)Ⓛ	UJ331		U-Joint (Front)Ⓛ	UJ354
	<i>Brute Force Greaseable</i>	UJ232		<i>Brute Force Greaseable</i>	UJ270
	<i>Brute Force Non Greaseable</i>	UJ231		<i>Brute Force Non Greaseable</i>	UJ254
	(For Aluminum Drive Shaft)	UJ331C		(For Aluminum Drive Shaft)	UJ354C
	Clamp Kit (Front)	UJ492-10		U-Joint (Rear)Ⓢ	UJ355
	U-Joint (Center)Ⓢ	UJ331		<i>Brute Force Greaseable</i>	UJ290
	<i>Brute Force Greaseable</i>	UJ232		(For Aluminum Drive Shaft)	UJ355C
	<i>Brute Force Non Greaseable</i>	UJ231		Clamp Kit (Rear)	UJ530-10
	(For Aluminum Drive Shaft)	UJ331C			(Continued)
	Clamp Kit (Center)	UJ492-10			
	U-Joint (Rear)Ⓢ	UJ331			
	<i>Brute Force Greaseable</i>	UJ232			
	<i>Brute Force Non Greaseable</i>	UJ231			
	(For Aluminum Drive Shaft)	UJ331C			
	Clamp Kit (Rear)	UJ492-10			
1993-1992	C1500 w/ Reg. Cab & Short Bed: [Type 1]				
	U-Joint (Front)Ⓛ	UJ534G			
	<i>Brute Force Greaseable</i>	UJ235			
	<i>Brute Force Non Greaseable</i>	UJ234			
	Clamp Kit (Front)	UJ530-10			
	U-Joint (Rear)Ⓢ	UJ534G			
	<i>Brute Force Greaseable</i>	UJ235			
	<i>Brute Force Non Greaseable</i>	UJ234			
	Clamp Kit (Rear)	UJ530-10			

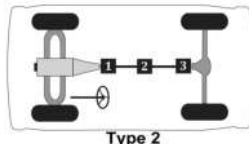
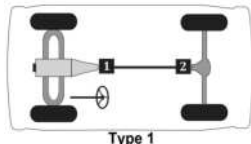

Passenger cars, light & medium trucks

(Cont.) -- Chevrolet/GMC Truck 1/2 ton

MFG./YEAR	MODEL & LOCATION	PART NO.	MFG./YEAR	MODEL & LOCATION	PART NO.
Drive Shaft (2 W/D) (Cont.)			Drive Shaft (2 W/D) (Cont.)		
U-Joint (Cont.)			U-Joint (Cont.)		
1993-1991 C1500 w/ Ext. Cab & MG5 Man.Trans.:			1991 C1500 w/ Reg. Cab & 3 Joint Shaft:		
[Type 2]			[Type 2]		
U-Joint (Front)Ⓢ		UJ354	U-Joint (Front)Ⓢ		UJ331
<i>Brute Force Greaseable</i>		UJ270	<i>Brute Force Greaseable</i>		UJ232
<i>Brute Force Non Greaseable</i>		UJ254	<i>Brute Force Non Greaseable</i>		UJ231
(For Aluminum Drive Shaft)		UJ354C	(For Aluminum Drive Shaft)		UJ331C
U-Joint (Center)Ⓢ		UJ354	Clamp Kit (Front)		UJ492-10
<i>Brute Force Greaseable</i>		UJ270	U-Joint (Center)Ⓢ		UJ331
<i>Brute Force Non Greaseable</i>		UJ254	<i>Brute Force Greaseable</i>		UJ232
(For Aluminum Drive Shaft)		UJ354C	<i>Brute Force Non Greaseable</i>		UJ231
U-Joint (Rear)Ⓢ		UJ355	(For Aluminum Drive Shaft)		UJ331C
<i>Brute Force Greaseable</i>		UJ290	Clamp Kit (Center)		UJ492-10
(For Aluminum Drive Shaft)		UJ355C	U-Joint (Rear)Ⓢ		UJ331
Clamp Kit (Rear)		UJ530-10	<i>Brute Force Greaseable</i>		UJ232
1993-1991 C1500 w/ Ext. Cab & MT8 Man.Trans.:			<i>Brute Force Non Greaseable</i>		UJ231
			(For Aluminum Drive Shaft)		UJ331C
			Clamp Kit (Rear)		UJ492-10
			1991 C1500 w/ Ext. Cab & Auto. Trans.:		
			[Type 2]		
			U-Joint (Front)Ⓢ		UJ534G
			<i>Brute Force Greaseable</i>		UJ235
			<i>Brute Force Non Greaseable</i>		UJ234
			Clamp Kit (Front)		UJ530-10
			U-Joint (Center)Ⓢ		UJ331
			<i>Brute Force Greaseable</i>		UJ232
			<i>Brute Force Non Greaseable</i>		UJ231
			(For Aluminum Drive Shaft)		UJ331C
			Clamp Kit (Center)		UJ492-10
			U-Joint (Rear)Ⓢ		UJ534G
			<i>Brute Force Greaseable</i>		UJ235
			<i>Brute Force Non Greaseable</i>		UJ234
			Clamp Kit (Rear)		UJ530-10
			1991-1988 C1500 w/ Ext. Cab & 4 Spd. Man. Trans.:		
			[Type 2]		
			U-Joint (Front)Ⓢ		UJ331
			<i>Brute Force Greaseable</i>		UJ232
			<i>Brute Force Non Greaseable</i>		UJ231
			(For Aluminum Drive Shaft)		UJ331C
			Clamp Kit (Front)		UJ492-10
			U-Joint (Center)Ⓢ		UJ331
			<i>Brute Force Greaseable</i>		UJ232
			<i>Brute Force Non Greaseable</i>		UJ231
			(For Aluminum Drive Shaft)		UJ331C
			Clamp Kit (Center)		UJ492-10
			U-Joint (Rear)Ⓢ		UJ331
			<i>Brute Force Greaseable</i>		UJ232
			<i>Brute Force Non Greaseable</i>		UJ231
			(For Aluminum Drive Shaft)		UJ331C
			Clamp Kit (Rear)		UJ492-10

(Continued)

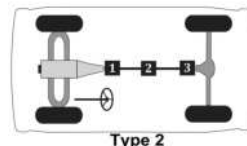
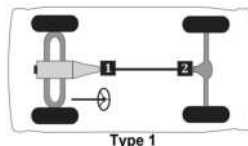

Passenger cars, light & medium trucks

Chevrolet/GMC Truck 1/2 ton -- (Cont.)

MFG./YEAR	MODEL & LOCATION	PART NO.	MFG./YEAR	MODEL & LOCATION	PART NO.
-----------	------------------	----------	-----------	------------------	----------

Drive Shaft (2 W/D) (Cont.)

U-Joint (Cont.)

1991-1987 Suburban w/ 3 Joint Shaft: [Type 2]	
U-Joint (Front)❶	UJ534G
Brute Force Greaseable	UJ235
Brute Force Non Greaseable	UJ234
Clamp Kit (Front)	UJ530-10
U-Joint (Center)Ⓣ	UJ534G
Brute Force Greaseable	UJ235
Brute Force Non Greaseable	UJ234
Clamp Kit (Center)	UJ530-10
U-Joint (Rear)Ⓣ	UJ534G
Brute Force Greaseable	UJ235
Brute Force Non Greaseable	UJ234
Clamp Kit (Rear)	UJ530-10
1991-1982 Suburban w/ 2 Joint Shaft: [Type 1]	
U-Joint (Front)❶	UJ534G
Brute Force Greaseable	UJ235
Brute Force Non Greaseable	UJ234
Clamp Kit (Front)	UJ530-10
U-Joint (Rear)Ⓣ	UJ534G
Brute Force Greaseable	UJ235
Brute Force Non Greaseable	UJ234
Clamp Kit (Rear)	UJ530-10
1990-1989 C1500 w/ Reg. Cab, 2 Joint Steel Shaft & Inner Lock Rings: [Type 1]	
U-Joint (Front)❶	UJ534G
Brute Force Greaseable	UJ235
Brute Force Non Greaseable	UJ234
Clamp Kit (Front)	UJ530-10
U-Joint (Rear)Ⓣ	UJ534G
Brute Force Greaseable	UJ235
Brute Force Non Greaseable	UJ234
Clamp Kit (Rear)	UJ530-10
1990-1989 C1500 w/ Reg. Cab, 2 Joint Steel Shaft & Outer Lock Rings: [Type 1]	
U-Joint (Front)❶	UJ331
Brute Force Greaseable	UJ232
Brute Force Non Greaseable	UJ231
(For Aluminum Drive Shaft)	UJ331C
Clamp Kit (Front)	UJ492-10
U-Joint (Rear)Ⓣ	UJ331
Brute Force Greaseable	UJ232
Brute Force Non Greaseable	UJ231
(For Aluminum Drive Shaft)	UJ331C
Clamp Kit (Rear)	UJ492-10

Drive Shaft (2 W/D) (Cont.)

U-Joint (Cont.)

1990-1989 C1500 w/ Ext. Cab, Short Bed & Auto. Trans.: [Type 2]	
U-Joint (Front)❶	UJ534G
Brute Force Greaseable	UJ235
Brute Force Non Greaseable	UJ234
Clamp Kit (Front)	UJ530-10
U-Joint (Center)Ⓣ	UJ534G
Brute Force Greaseable	UJ235
Brute Force Non Greaseable	UJ234
Clamp Kit (Center)	UJ530-10
U-Joint (Rear)Ⓣ	UJ534G
Brute Force Greaseable	UJ235
Brute Force Non Greaseable	UJ234
Clamp Kit (Rear)	UJ530-10
1990-1989 C1500 w/ Ext. Cab, Long Bed & Auto. Trans.: [Type 2]	
U-Joint (Front)❶	UJ534G
Brute Force Greaseable	UJ235
Brute Force Non Greaseable	UJ234
Clamp Kit (Front)	UJ530-10
U-Joint (Center)Ⓣ	UJ331
Brute Force Greaseable	UJ232
Brute Force Non Greaseable	UJ231
(For Aluminum Drive Shaft)	UJ331C
Clamp Kit (Center)	UJ492-10
U-Joint (Rear)Ⓣ	UJ534G
Brute Force Greaseable	UJ235
Brute Force Non Greaseable	UJ234
Clamp Kit (Rear)	UJ530-10
1990-1989 C1500 w/ Ext. Cab & 5 Spd. Man. Trans.: [Type 2]	
U-Joint (Front)❶	UJ354
Brute Force Greaseable	UJ270
Brute Force Non Greaseable	UJ254
(For Aluminum Drive Shaft)	UJ354C
U-Joint (Center)Ⓣ	UJ354
Brute Force Greaseable	UJ270
Brute Force Non Greaseable	UJ254
(For Aluminum Drive Shaft)	UJ354C
U-Joint (Rear)Ⓣ	UJ355
Brute Force Greaseable	UJ290
(For Aluminum Drive Shaft)	UJ355C
Clamp Kit (Rear)	UJ530-10
1990-1988 C1500 w/ Reg. Cab & 2 Joint Alum. Shaft: [Type 1]	
U-Joint (Front)❶	UJ354
Brute Force Greaseable	UJ270
Brute Force Non Greaseable	UJ254
(For Aluminum Drive Shaft)	UJ354C
U-Joint (Rear)Ⓣ	UJ355
Brute Force Greaseable	UJ290
(For Aluminum Drive Shaft)	UJ355C
Clamp Kit (Rear)	UJ530-10

(Continued)

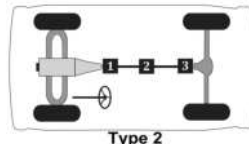
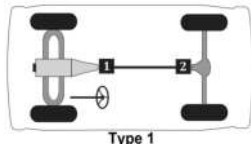

Passenger cars, light & medium trucks

(Cont.) -- Chevrolet/GMC Truck 1/2 ton

MFG./YEAR	MODEL & LOCATION	PART NO.	MFG./YEAR	MODEL & LOCATION	PART NO.
Drive Shaft (2 W/D) (Cont.)			Drive Shaft (2 W/D) (Cont.)		
U-Joint (Cont.)			U-Joint (Cont.)		
1990-1988 C1500 w/ Reg. Cab & 3 Joint Shaft:			1988 C1500 w/ Ext. Cab, 5 Spd. Man. Trans. & Inner Lock Rings: [Type 2]		
[Type 2]					
	U-Joint (Front)Ⓢ	UJ331		U-Joint (Front)Ⓢ	UJ534G
	<i>Brute Force Greaseable</i>	UJ232		<i>Brute Force Greaseable</i>	UJ235
	<i>Brute Force Non Greaseable</i>	UJ231		<i>Brute Force Non Greaseable</i>	UJ234
	(For Aluminum Drive Shaft)	UJ331C		Clamp Kit (Front)	UJ530-10
	Clamp Kit (Front)	UJ492-10		U-Joint (Center)Ⓢ	UJ534G
	U-Joint (Center)Ⓢ	UJ331		<i>Brute Force Greaseable</i>	UJ235
	<i>Brute Force Greaseable</i>	UJ232		<i>Brute Force Non Greaseable</i>	UJ234
	<i>Brute Force Non Greaseable</i>	UJ231		Clamp Kit (Center)	UJ530-10
	(For Aluminum Drive Shaft)	UJ331C		U-Joint (Rear)Ⓢ	UJ534G
	Clamp Kit (Center)	UJ492-10		<i>Brute Force Greaseable</i>	UJ235
	U-Joint (Rear)Ⓢ	UJ331		<i>Brute Force Non Greaseable</i>	UJ234
	<i>Brute Force Greaseable</i>	UJ232		Clamp Kit (Rear)	UJ530-10
	<i>Brute Force Non Greaseable</i>	UJ231		1988 C1500 w/ Ext. Cab, 5 Spd. Man. Trans. & Outer Lock Rings: [Type 2]	
	(For Aluminum Drive Shaft)	UJ331C			
	Clamp Kit (Rear)	UJ492-10		U-Joint (Front)Ⓢ	UJ354
	1988 C1500 w/ Reg. Cab & 2 Joint Steel Shaft: [Type 1]			<i>Brute Force Greaseable</i>	UJ270
				<i>Brute Force Non Greaseable</i>	UJ254
	U-Joint (Front)Ⓢ	UJ534G		(For Aluminum Drive Shaft)	UJ354C
	<i>Brute Force Greaseable</i>	UJ235		U-Joint (Center)Ⓢ	UJ354
	<i>Brute Force Non Greaseable</i>	UJ234		<i>Brute Force Greaseable</i>	UJ270
	Clamp Kit (Front)	UJ530-10		<i>Brute Force Non Greaseable</i>	UJ254
	U-Joint (Rear)Ⓢ	UJ534G		(For Aluminum Drive Shaft)	UJ354C
	<i>Brute Force Greaseable</i>	UJ235		U-Joint (Rear)Ⓢ	UJ355
	<i>Brute Force Non Greaseable</i>	UJ234		<i>Brute Force Greaseable</i>	UJ290
	Clamp Kit (Rear)	UJ530-10		(For Aluminum Drive Shaft)	UJ355C
	1988 C1500 w/ Ext. Cab & Auto. Trans.: [Type 2]			Clamp Kit (Rear)	UJ530-10
				1987 R10 & R1500 w/ 2 Joint Shaft: [Type 1]	
	U-Joint (Front)Ⓢ	UJ534G			
	<i>Brute Force Greaseable</i>	UJ235		U-Joint (Front)Ⓢ	UJ534G
	<i>Brute Force Non Greaseable</i>	UJ234		<i>Brute Force Greaseable</i>	UJ235
	Clamp Kit (Front)	UJ530-10		<i>Brute Force Non Greaseable</i>	UJ234
	U-Joint (Center)Ⓢ	UJ331		Clamp Kit (Front)	UJ530-10
	<i>Brute Force Greaseable</i>	UJ232		U-Joint (Rear)Ⓢ	UJ534G
	<i>Brute Force Non Greaseable</i>	UJ231		<i>Brute Force Greaseable</i>	UJ235
	(For Aluminum Drive Shaft)	UJ331C		<i>Brute Force Non Greaseable</i>	UJ234
	Clamp Kit (Center)	UJ492-10		Clamp Kit (Rear)	UJ530-10
	U-Joint (Rear)Ⓢ	UJ534G			(Continued)
	<i>Brute Force Greaseable</i>	UJ235			
	<i>Brute Force Non Greaseable</i>	UJ234			
	Clamp Kit (Rear)	UJ530-10			

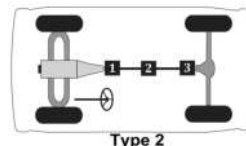
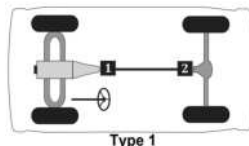

Passenger cars, light & medium trucks

Chevrolet/GMC Truck 1/2 ton -- (Cont.)

MFG./YEAR	MODEL & LOCATION	PART NO.	MFG./YEAR	MODEL & LOCATION	PART NO.
Drive Shaft (2 W/D) (Cont.)			Drive Shaft (2 W/D) (Cont.)		
U-Joint (Cont.)			U-Joint (Cont.)		
1987	R10 & R1500 w/ 3 Joint Shaft, 4 Spd. Man. Trans. & V6 Eng.: [Type 2]		1986-1982	Suburban w/ 3 Joint Shaft & Inner Lock Ring: [Type 2]	
U-Joint (Front)Ⓛ		UJ331	U-Joint (Front)Ⓛ		UJ534G
Brute Force Greaseable		UJ232	Brute Force Greaseable		UJ235
Brute Force Non Greaseable		UJ231	Brute Force Non Greaseable		UJ234
(For Aluminum Drive Shaft)		UJ331C	Clamp Kit (Front)		UJ530-10
Clamp Kit (Front)		UJ492-10	U-Joint (Center)Ⓢ		UJ534G
U-Joint (Center)Ⓢ		UJ534G	Brute Force Greaseable		UJ235
Brute Force Greaseable		UJ235	Brute Force Non Greaseable		UJ234
Brute Force Non Greaseable		UJ234	Clamp Kit (Center)		UJ530-10
Clamp Kit (Center)		UJ530-10	U-Joint (Rear)Ⓢ		UJ534G
U-Joint (Rear)Ⓢ		UJ534G	Brute Force Greaseable		UJ235
Brute Force Greaseable		UJ235	Brute Force Non Greaseable		UJ234
Brute Force Non Greaseable		UJ234	Clamp Kit (Rear)		UJ530-10
Clamp Kit (Rear)		UJ530-10	1986-1982 Suburban w/ 3 Joint Shaft & Outer Lock Ring: [Type 2]		
1987	R10 & R1500 w/ 3 Joint Shaft, 4 Spd. Man. Trans. & V8 Eng.: [Type 2]		U-Joint (Front)Ⓛ		UJ331
U-Joint (Front)Ⓛ		UJ331	Brute Force Greaseable		UJ232
Brute Force Greaseable		UJ232	Brute Force Non Greaseable		UJ231
Brute Force Non Greaseable		UJ231	(For Aluminum Drive Shaft)		UJ331C
(For Aluminum Drive Shaft)		UJ331C	Clamp Kit (Front)		UJ492-10
Clamp Kit (Front)		UJ492-10	U-Joint (Center)Ⓢ		UJ331
U-Joint (Center)Ⓢ		UJ331	Brute Force Greaseable		UJ232
Brute Force Greaseable		UJ232	Brute Force Non Greaseable		UJ231
Brute Force Non Greaseable		UJ231	(For Aluminum Drive Shaft)		UJ331C
(For Aluminum Drive Shaft)		UJ331C	Clamp Kit (Center)		UJ492-10
Clamp Kit (Center)		UJ492-10	U-Joint (Rear)Ⓢ		UJ331
U-Joint (Rear)Ⓢ		UJ331	Brute Force Greaseable		UJ232
Brute Force Greaseable		UJ232	Brute Force Non Greaseable		UJ231
Brute Force Non Greaseable		UJ231	(For Aluminum Drive Shaft)		UJ331C
(For Aluminum Drive Shaft)		UJ331C	Clamp Kit (Rear)		UJ492-10
Clamp Kit (Rear)		UJ492-10	1986-1982 C10 & C1500 w/ 2 Joint Shaft: [Type 1]		
1987	R10 & R1500 w/ 3 Joint Shaft w/o 4 Spd. Man. Trans: [Type 2]		U-Joint (Front)Ⓛ		UJ534G
U-Joint (Front)Ⓛ		UJ534G	Brute Force Greaseable		UJ235
Brute Force Greaseable		UJ235	Brute Force Non Greaseable		UJ234
Brute Force Non Greaseable		UJ234	Clamp Kit (Front)		UJ530-10
Clamp Kit (Front)		UJ530-10	U-Joint (Rear)Ⓢ		UJ534G
U-Joint (Center)Ⓢ		UJ534G	Brute Force Greaseable		UJ235
Brute Force Greaseable		UJ235	Brute Force Non Greaseable		UJ234
Brute Force Non Greaseable		UJ234	Clamp Kit (Rear)		UJ530-10
Clamp Kit (Center)		UJ530-10			(Continued)
U-Joint (Rear)Ⓢ		UJ534G			
Brute Force Greaseable		UJ235			
Brute Force Non Greaseable		UJ234			
Clamp Kit (Rear)		UJ530-10			

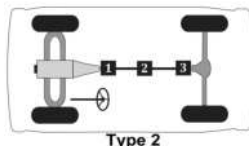
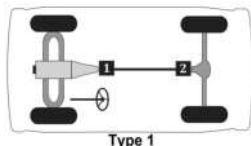

Passenger cars, light & medium trucks

(Cont.) -- Chevrolet/GMC Truck 1/2 ton

MFG./YEAR	MODEL & LOCATION	PART NO.	MFG./YEAR	MODEL & LOCATION	PART NO.
Drive Shaft (2 W/D) (Cont.)			Drive Shaft (2 W/D) (Cont.)		
U-Joint (Cont.)			U-Joint (Cont.)		
1986-1982 C10 & C1500 w/ 3 Joint Shaft & Inner			1981-1979 Suburban w/ 2 Joint Shaft: [Type 1]		
Lock Rings: [Type 2]			U-Joint (Front)ⓈUJ369		
U-Joint (Front)Ⓢ		UJ534G	<i>Brute Force Greaseable</i>		UJ280
<i>Brute Force Greaseable</i>		UJ235	<i>Brute Force Non Greaseable</i>		UJ269
<i>Brute Force Non Greaseable</i>		UJ234	(For Aluminum Drive Shaft)		UJ369C
Clamp Kit (Front)		UJ530-10	Clamp Kit (Front)		UJ360-10
U-Joint (Center)Ⓢ		UJ534G	U-Joint (Rear)Ⓢ		UJ369
<i>Brute Force Greaseable</i>		UJ235	<i>Brute Force Greaseable</i>		UJ280
<i>Brute Force Non Greaseable</i>		UJ234	<i>Brute Force Non Greaseable</i>		UJ269
Clamp Kit (Center)		UJ530-10	(For Aluminum Drive Shaft)		UJ369C
U-Joint (Rear)Ⓢ		UJ534G	Clamp Kit (Rear)		UJ360-10
<i>Brute Force Greaseable</i>		UJ235	1981-1979 Suburban w/ THM400 Trans., 4 Spd.		
<i>Brute Force Non Greaseable</i>		UJ234	Man. Trans. & 3 Joint Rear Shaft:		
Clamp Kit (Rear)		UJ530-10	[Type 2]		
1986-1982 C10 & C1500 w/ 3 Joint Shaft & Outer			U-Joint (Front)Ⓢ		UJ369
Lock Rings: [Type 2]			<i>Brute Force Greaseable</i>		UJ280
U-Joint (Front)Ⓢ		UJ331	<i>Brute Force Non Greaseable</i>		UJ269
<i>Brute Force Greaseable</i>		UJ232	(For Aluminum Drive Shaft)		UJ369C
<i>Brute Force Non Greaseable</i>		UJ231	Clamp Kit (Front)		UJ360-10
(For Aluminum Drive Shaft)		UJ331C	U-Joint (Center)Ⓢ		UJ369
Clamp Kit (Front)		UJ492-10	<i>Brute Force Greaseable</i>		UJ280
U-Joint (Center)Ⓢ		UJ331	<i>Brute Force Non Greaseable</i>		UJ269
<i>Brute Force Greaseable</i>		UJ232	(For Aluminum Drive Shaft)		UJ369C
<i>Brute Force Non Greaseable</i>		UJ231	Clamp Kit (Center)		UJ360-10
(For Aluminum Drive Shaft)		UJ331C	U-Joint (Rear)Ⓢ		UJ369
Clamp Kit (Center)		UJ492-10	<i>Brute Force Greaseable</i>		UJ280
U-Joint (Rear)Ⓢ		UJ331	<i>Brute Force Non Greaseable</i>		UJ269
<i>Brute Force Greaseable</i>		UJ232	(For Aluminum Drive Shaft)		UJ369C
<i>Brute Force Non Greaseable</i>		UJ231	Clamp Kit (Rear)		UJ360-10
(For Aluminum Drive Shaft)		UJ331C	1981-1979 Suburban w/ 3 Joint Shaft Exc.		
Clamp Kit (Rear)		UJ492-10	THM400 4 Spd. Man. Trans.: [Type 2]		
1982 Blazer & Jimmy Exc. 4 Spd. Man.			U-Joint (Front)Ⓢ		UJ331
Trans.: [Type 1]			<i>Brute Force Greaseable</i>		UJ232
U-Joint (Front)Ⓢ		UJ534G	<i>Brute Force Non Greaseable</i>		UJ231
<i>Brute Force Greaseable</i>		UJ235	(For Aluminum Drive Shaft)		UJ331C
<i>Brute Force Non Greaseable</i>		UJ234	Clamp Kit (Front)		UJ492-10
Clamp Kit (Front)		UJ530-10	U-Joint (Center)Ⓢ		UJ331
U-Joint (Rear)Ⓢ		UJ534G	<i>Brute Force Greaseable</i>		UJ232
<i>Brute Force Greaseable</i>		UJ235	<i>Brute Force Non Greaseable</i>		UJ231
<i>Brute Force Non Greaseable</i>		UJ234	(For Aluminum Drive Shaft)		UJ331C
Clamp Kit (Rear)		UJ530-10	Clamp Kit (Center)		UJ492-10
1982 Blazer & Jimmy w/ 4 Spd. Man.			U-Joint (Rear)Ⓢ		UJ331
Trans.: [Type 1]			<i>Brute Force Greaseable</i>		UJ232
U-Joint (Front)Ⓢ		UJ331	<i>Brute Force Non Greaseable</i>		UJ231
<i>Brute Force Greaseable</i>		UJ232	(For Aluminum Drive Shaft)		UJ331C
<i>Brute Force Non Greaseable</i>		UJ231	Clamp Kit (Rear)		UJ492-10
(For Aluminum Drive Shaft)		UJ331C	(Continued)		
Clamp Kit (Front)		UJ492-10			
U-Joint (Rear)Ⓢ		UJ331			
<i>Brute Force Greaseable</i>		UJ232			
<i>Brute Force Non Greaseable</i>		UJ231			
(For Aluminum Drive Shaft)		UJ331C			
Clamp Kit (Rear)		UJ492-10			

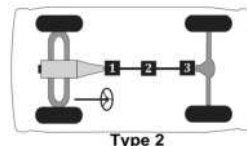
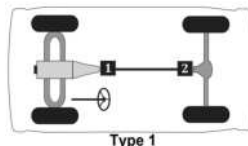

Passenger cars, light & medium trucks

Chevrolet/GMC Truck 1/2 ton -- (Cont.)

MFG./YEAR	MODEL & LOCATION	PART NO.	MFG./YEAR	MODEL & LOCATION	PART NO.
Drive Shaft (2 W/D) (Cont.)			Drive Shaft (2 W/D) (Cont.)		
U-Joint (Cont.)			U-Joint (Cont.)		
1981-1979 C10 & C1500 w/ 3 Joint Shaft, 1.063"			1981-1979 C10 & C1500 w/ 3 Joint Shaft, 1.188"		
Dia. Brg. Cap & 3.5" Rear Yoke:			Dia. Brg. Cap & 3.875" Rear Yoke:		
[Type 2]			[Type 2]		
U-Joint (Front)Ⓚ		UJ369	U-Joint (Front)Ⓚ		UJ331
<i>Brute Force Greaseable</i>		UJ280	<i>Brute Force Greaseable</i>		UJ232
<i>Brute Force Non Greaseable</i>		UJ269	<i>Brute Force Non Greaseable</i>		UJ231
(For Aluminum Drive Shaft)		UJ369C	(For Aluminum Drive Shaft)		UJ331C
Clamp Kit (Front)		UJ360-10	Clamp Kit (Front)		UJ492-10
U-Joint (Center)Ⓛ		UJ369	U-Joint (Center)Ⓛ		UJ331
<i>Brute Force Greaseable</i>		UJ280	<i>Brute Force Greaseable</i>		UJ232
<i>Brute Force Non Greaseable</i>		UJ269	<i>Brute Force Non Greaseable</i>		UJ231
(For Aluminum Drive Shaft)		UJ369C	(For Aluminum Drive Shaft)		UJ331C
Clamp Kit (Center)		UJ360-10	Clamp Kit (Center)		UJ492-10
U-Joint (Rear)Ⓛ		UJ369	U-Joint (Rear)Ⓛ		UJ355
<i>Brute Force Greaseable</i>		UJ280	<i>Brute Force Greaseable</i>		UJ290
<i>Brute Force Non Greaseable</i>		UJ269	<i>Brute Force Non Greaseable</i>		UJ355C
(For Aluminum Drive Shaft)		UJ369C	(For Aluminum Drive Shaft)		
Clamp Kit (Rear)		UJ360-10	1981-1978 C10 & C1500 w/ 2 Joint Shaft: [Type 1]		
1981-1979 C10 & C1500 w/ 3 Joint Shaft, 1.188"			U-Joint (Front)Ⓚ		UJ369
Dia. Brg. Cap & 3.5" Rear Yoke:			<i>Brute Force Greaseable</i>		UJ280
[Type 2]			<i>Brute Force Non Greaseable</i>		UJ269
U-Joint (Front)Ⓚ		UJ331	(For Aluminum Drive Shaft)		UJ369C
<i>Brute Force Greaseable</i>		UJ232	Clamp Kit (Front)		UJ360-10
<i>Brute Force Non Greaseable</i>		UJ231	U-Joint (Rear)Ⓛ		UJ369
(For Aluminum Drive Shaft)		UJ331C	<i>Brute Force Greaseable</i>		UJ280
Clamp Kit (Front)		UJ492-10	<i>Brute Force Non Greaseable</i>		UJ269
U-Joint (Center)Ⓛ		UJ331	(For Aluminum Drive Shaft)		UJ369C
<i>Brute Force Greaseable</i>		UJ232	Clamp Kit (Rear)		UJ360-10
<i>Brute Force Non Greaseable</i>		UJ231	1981-1969 Blazer & Jimmy Exc. 4 Spd. Man.		
(For Aluminum Drive Shaft)		UJ331C	Trans.: [Type 1]		
Clamp Kit (Center)		UJ492-10	U-Joint (Front)Ⓚ		UJ369
U-Joint (Rear)Ⓛ		UJ369	<i>Brute Force Greaseable</i>		UJ280
<i>Brute Force Greaseable</i>		UJ280	<i>Brute Force Non Greaseable</i>		UJ269
<i>Brute Force Non Greaseable</i>		UJ269	(For Aluminum Drive Shaft)		UJ369C
(For Aluminum Drive Shaft)		UJ369C	U-Bolt Kit (Front)		UJ329-10
Clamp Kit (Rear)		UJ360-10	U-Joint (Rear)Ⓛ		UJ369
1981-1979 C10 & C1500 w/ 3 Joint Shaft, 1.063"			<i>Brute Force Greaseable</i>		UJ280
Dia. Brg. Cap & 3.875" Rear Yoke:			<i>Brute Force Non Greaseable</i>		UJ269
[Type 2]			(For Aluminum Drive Shaft)		UJ369C
U-Joint (Front)Ⓚ		UJ369	U-Bolt Kit (Rear)		UJ329-10
<i>Brute Force Greaseable</i>		UJ280	1981-1969 Blazer & Jimmy w/ 4 Spd. Man.		
<i>Brute Force Non Greaseable</i>		UJ269	Trans.: [Type 1]		
(For Aluminum Drive Shaft)		UJ369C	U-Joint (Front)Ⓚ		UJ331
Clamp Kit (Front)		UJ360-10	<i>Brute Force Greaseable</i>		UJ232
U-Joint (Center)Ⓛ		UJ369	<i>Brute Force Non Greaseable</i>		UJ231
<i>Brute Force Greaseable</i>		UJ280	(For Aluminum Drive Shaft)		UJ331C
<i>Brute Force Non Greaseable</i>		UJ269	Clamp Kit (Front)		UJ492-10
(For Aluminum Drive Shaft)		UJ369C	U-Joint (Rear)Ⓛ		UJ369
Clamp Kit (Center)		UJ360-10	<i>Brute Force Greaseable</i>		UJ280
U-Joint (Rear)Ⓛ		UJ355	<i>Brute Force Non Greaseable</i>		UJ269
<i>Brute Force Greaseable</i>		UJ290	(For Aluminum Drive Shaft)		UJ369C
(For Aluminum Drive Shaft)		UJ355C	U-Bolt Kit (Rear)		UJ329-10

(Continued)

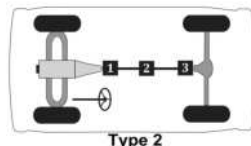
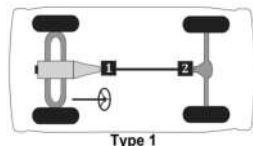

Passenger cars, light & medium trucks

(Cont.) -- Chevrolet/GMC Truck 1/2 ton

MFG./YEAR	MODEL & LOCATION	PART NO.	MFG./YEAR	MODEL & LOCATION	PART NO.
Drive Shaft (2 W/D) (Cont.)			Drive Shaft (2 W/D) (Cont.)		
U-Joint (Cont.)			U-Joint (Cont.)		
1978	C10, C15 & Suburban w/ 3 Joint Shaft & THM400 Auto. Trans.: [Type 2]		1978-1971	C10, C15 & Suburban w/ 3 Joint Shaft & THM350 Auto. Trans.: [Type 2]	
	U-Joint (Front)Ⓢ	UJ331		U-Joint (Front)Ⓢ	UJ369
	<i>Brute Force Greaseable</i>	UJ232		<i>Brute Force Greaseable</i>	UJ280
	<i>Brute Force Non Greaseable</i>	UJ231		<i>Brute Force Non Greaseable</i>	UJ269
	(For Aluminum Drive Shaft)	UJ331C		(For Aluminum Drive Shaft)	UJ369C
	U-Joint (Center)Ⓢ	UJ534G		Clamp Kit (Front)	UJ360-10
	<i>Brute Force Greaseable</i>	UJ235		U-Joint (Center)Ⓢ	UJ369
	<i>Brute Force Non Greaseable</i>	UJ234		<i>Brute Force Greaseable</i>	UJ280
	U-Joint (Rear)Ⓢ	UJ331		<i>Brute Force Non Greaseable</i>	UJ269
	<i>Brute Force Greaseable</i>	UJ232		(For Aluminum Drive Shaft)	UJ369C
	<i>Brute Force Non Greaseable</i>	UJ231		Clamp Kit (Center)	UJ360-10
	(For Aluminum Drive Shaft)	UJ331C		U-Joint (Rear)Ⓢ	UJ369
1978-1973	C10, C15 & Suburban w/ 3 Joint Shaft & Std. 3 Spd. Man. Trans.: [Type 2]			<i>Brute Force Greaseable</i>	UJ280
	U-Joint (Front)Ⓢ	UJ369		<i>Brute Force Non Greaseable</i>	UJ269
	<i>Brute Force Greaseable</i>	UJ280		(For Aluminum Drive Shaft)	UJ369C
	<i>Brute Force Non Greaseable</i>	UJ269		Clamp Kit (Front)	UJ360-10
	(For Aluminum Drive Shaft)	UJ369C		U-Joint (Center)Ⓢ	UJ369
	Clamp Kit (Front)	UJ360-10		<i>Brute Force Greaseable</i>	UJ280
	U-Joint (Center)Ⓢ	UJ369		<i>Brute Force Non Greaseable</i>	UJ269
	<i>Brute Force Greaseable</i>	UJ280		(For Aluminum Drive Shaft)	UJ369C
	<i>Brute Force Non Greaseable</i>	UJ269		Clamp Kit (Center)	UJ360-10
	(For Aluminum Drive Shaft)	UJ369C		U-Joint (Rear)Ⓢ	UJ369
	Clamp Kit (Center)	UJ360-10		<i>Brute Force Greaseable</i>	UJ280
	U-Joint (Rear)Ⓢ	UJ369		<i>Brute Force Non Greaseable</i>	UJ269
	<i>Brute Force Greaseable</i>	UJ280		(For Aluminum Drive Shaft)	UJ369C
	<i>Brute Force Non Greaseable</i>	UJ269		Clamp Kit (Rear)	UJ360-10
	(For Aluminum Drive Shaft)	UJ369C		1977-1973 C10, C15 & Suburban w/ 3 Joint Shaft & THM400 Auto. Trans.: [Type 2]	
	Clamp Kit (Rear)	UJ360-10		U-Joint (Front)Ⓢ	UJ354
1978-1973	C10, C15 & Suburban w/ 3 Joint Shaft & HD 3 Spd. Man. & 4 Spd. Man. Trans.: [Type 2]			<i>Brute Force Greaseable</i>	UJ270
	U-Joint (Front)Ⓢ	UJ331		<i>Brute Force Non Greaseable</i>	UJ254
	<i>Brute Force Greaseable</i>	UJ232		(For Aluminum Drive Shaft)	UJ354C
	<i>Brute Force Non Greaseable</i>	UJ231		U-Joint (Center)Ⓢ	UJ369
	(For Aluminum Drive Shaft)	UJ331C		<i>Brute Force Greaseable</i>	UJ280
	U-Joint (Center)Ⓢ	UJ369		<i>Brute Force Non Greaseable</i>	UJ269
	<i>Brute Force Greaseable</i>	UJ280		(For Aluminum Drive Shaft)	UJ369C
	<i>Brute Force Non Greaseable</i>	UJ269		Clamp Kit (Center)	UJ360-10
	(For Aluminum Drive Shaft)	UJ369C		U-Joint (Rear)Ⓢ	UJ369
	Clamp Kit (Center)	UJ360-10		<i>Brute Force Greaseable</i>	UJ280
	U-Joint (Rear)Ⓢ	UJ369		<i>Brute Force Non Greaseable</i>	UJ269
	<i>Brute Force Greaseable</i>	UJ280		(For Aluminum Drive Shaft)	UJ369C
	<i>Brute Force Non Greaseable</i>	UJ269		Clamp Kit (Rear)	UJ360-10
	(For Aluminum Drive Shaft)	UJ369C		1977-1973 C10, C15 & Suburban w/ 2 Joint Shaft & THM350 Auto. Trans.: [Type 1]	
	Clamp Kit (Rear)	UJ360-10		U-Joint (Front)Ⓢ	UJ369
				<i>Brute Force Greaseable</i>	UJ280
				<i>Brute Force Non Greaseable</i>	UJ269
				(For Aluminum Drive Shaft)	UJ369C
				Clamp Kit (Front)	UJ360-10
				U-Joint (Rear)Ⓢ	UJ369
				<i>Brute Force Greaseable</i>	UJ280
				<i>Brute Force Non Greaseable</i>	UJ269
				(For Aluminum Drive Shaft)	UJ369C
				Clamp Kit (Rear)	UJ360-10

(Continued)

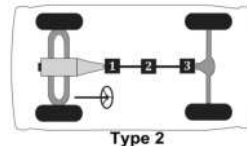
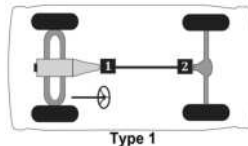

Passenger cars, light & medium trucks

Chevrolet/GMC Truck 1/2 ton -- (Cont.)

MFG./YEAR	MODEL & LOCATION	PART NO.	MFG./YEAR	MODEL & LOCATION	PART NO.
-----------	------------------	----------	-----------	------------------	----------

Drive Shaft (2 W/D) (Cont.)

U-Joint (Cont.)

1977-1973 C10, C15 & Suburban w/ 2 Joint Shaft
& THM400 Auto. Trans.: [Type 1]

U-Joint (Front)⊙	UJ354
Brute Force Greaseable	UJ270
Brute Force Non Greaseable	UJ254
(For Aluminum Drive Shaft)	UJ354C
U-Joint (Rear)⊙	UJ369
Brute Force Greaseable	UJ280
Brute Force Non Greaseable	UJ269
(For Aluminum Drive Shaft)	UJ369C
Clamp Kit (Rear)	UJ360-10

1977-1973 C10, C15 & Suburban w/ 2 Joint Shaft
& Std. 3 Spd. Man. Trans.: [Type 1]

U-Joint (Front)⊙	UJ369
Brute Force Greaseable	UJ280
Brute Force Non Greaseable	UJ269
(For Aluminum Drive Shaft)	UJ369C
Clamp Kit (Front)	UJ360-10
U-Joint (Rear)⊙	UJ369
Brute Force Greaseable	UJ280
Brute Force Non Greaseable	UJ269
(For Aluminum Drive Shaft)	UJ369C
Clamp Kit (Rear)	UJ360-10

1977-1973 C10, C15 & Suburban w/ 2 Joint Shaft
& HD 3 Spd. Man. & 4 Spd. Man.
Trans.: [Type 1]

U-Joint (Front)⊙	UJ331
Brute Force Greaseable	UJ232
Brute Force Non Greaseable	UJ231
(For Aluminum Drive Shaft)	UJ331C
U-Joint (Rear)⊙	UJ369
Brute Force Greaseable	UJ280
Brute Force Non Greaseable	UJ269
(For Aluminum Drive Shaft)	UJ369C
Clamp Kit (Rear)	UJ360-10

1972-1970 C10, C15 & Suburban w/ 3 Joint Shaft
& THM400 Auto. Trans.: [Type 2]

U-Joint (Front)⊙	UJ354
Brute Force Greaseable	UJ270
Brute Force Non Greaseable	UJ254
(For Aluminum Drive Shaft)	UJ354C
U-Bolt Kit (Front)	UJ329-10
U-Joint (Center)⊙	UJ331
Brute Force Greaseable	UJ232
Brute Force Non Greaseable	UJ231
(For Aluminum Drive Shaft)	UJ331C
U-Joint (Rear)⊙	UJ354
Brute Force Greaseable	UJ270
Brute Force Non Greaseable	UJ254
(For Aluminum Drive Shaft)	UJ354C
U-Bolt Kit (Rear)	UJ329-10

Drive Shaft (2 W/D) (Cont.)

U-Joint (Cont.)

1972-1970 C10, C15 & Suburban w/ 3 Joint Shaft
& 4 Spd. Man. Trans.: [Type 2]

U-Joint (Front)⊙	UJ331
Brute Force Greaseable	UJ232
Brute Force Non Greaseable	UJ231
(For Aluminum Drive Shaft)	UJ331C
U-Joint (Center)⊙	UJ369
Brute Force Greaseable	UJ280
Brute Force Non Greaseable	UJ269
(For Aluminum Drive Shaft)	UJ369C
U-Bolt Kit (Center)	UJ329-10
U-Joint (Rear)⊙	UJ369
Brute Force Greaseable	UJ280
Brute Force Non Greaseable	UJ269
(For Aluminum Drive Shaft)	UJ369C
U-Bolt Kit (Rear)	UJ329-10

1972-1967 C10, C15 & Suburban w/ 2 Joint Shaft
& 3 Spd. Man. Trans.: [Type 1]

U-Joint (Front)⊙	UJ369
Brute Force Greaseable	UJ280
Brute Force Non Greaseable	UJ269
(For Aluminum Drive Shaft)	UJ369C
U-Bolt Kit (Front)	UJ329-10
U-Joint (Rear)⊙	UJ369
Brute Force Greaseable	UJ280
Brute Force Non Greaseable	UJ269
(For Aluminum Drive Shaft)	UJ369C
U-Bolt Kit (Rear)	UJ329-10

1972-1967 C10, C15 & Suburban w/ 2 Joint Shaft
& 4 Spd. Man. Trans.: [Type 1]

U-Joint (Front)⊙	UJ331
Brute Force Greaseable	UJ232
Brute Force Non Greaseable	UJ231
(For Aluminum Drive Shaft)	UJ331C
U-Joint (Rear)⊙	UJ369
Brute Force Greaseable	UJ280
Brute Force Non Greaseable	UJ269
(For Aluminum Drive Shaft)	UJ369C
U-Bolt Kit (Rear)	UJ329-10

1972-1967 C10, C15 & Suburban w/ 2 Joint Shaft
& Auto. Trans.: [Type 1]

U-Joint (Front)⊙	UJ369
Brute Force Greaseable	UJ280
Brute Force Non Greaseable	UJ269
(For Aluminum Drive Shaft)	UJ369C
U-Bolt Kit (Front)	UJ329-10
U-Joint (Rear)⊙	UJ369
Brute Force Greaseable	UJ280
Brute Force Non Greaseable	UJ269
(For Aluminum Drive Shaft)	UJ369C
U-Bolt Kit (Rear)	UJ329-10

(Continued)

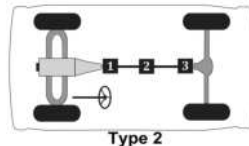
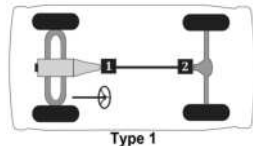

Passenger cars, light & medium trucks

(Cont.) -- Chevrolet/GMC Truck 1/2 ton

MFG./YEAR	MODEL & LOCATION	PART NO.	MFG./YEAR	MODEL & LOCATION	PART NO.
Drive Shaft (2 W/D) (Cont.)			Drive Shaft (2 W/D) (Cont.)		
U-Joint (Cont.)			U-Joint (Cont.)		
1972-1967 C10, C15 & Suburban w/ 3 Joint Shaft & 3 Spd. Man. Trans.: [Type 2]			1969-1968 C10, C15 & Suburban w/ 3 Joint Shaft & Auto. Trans. Exc. 396 Eng.: [Type 2]		
	U-Joint (Front)Ⓢ	UJ369		U-Joint (Front)Ⓢ	UJ369
	<i>Brute Force Greaseable</i>	UJ280		<i>Brute Force Greaseable</i>	UJ280
	<i>Brute Force Non Greaseable</i>	UJ269		<i>Brute Force Non Greaseable</i>	UJ269
	(For Aluminum Drive Shaft)	UJ369C		(For Aluminum Drive Shaft)	UJ369C
	U-Bolt Kit (Front)	UJ329-10		U-Bolt Kit (Front)	UJ329-10
	U-Joint (Center)Ⓢ	UJ369		U-Joint (Center)Ⓢ	UJ369
	<i>Brute Force Greaseable</i>	UJ280		<i>Brute Force Greaseable</i>	UJ280
	<i>Brute Force Non Greaseable</i>	UJ269		<i>Brute Force Non Greaseable</i>	UJ269
	(For Aluminum Drive Shaft)	UJ369C		(For Aluminum Drive Shaft)	UJ369C
	U-Bolt Kit (Center)	UJ329-10		U-Bolt Kit (Center)	UJ329-10
	U-Joint (Rear)Ⓢ	UJ369		U-Joint (Rear)Ⓢ	UJ369
	<i>Brute Force Greaseable</i>	UJ280		<i>Brute Force Greaseable</i>	UJ280
	<i>Brute Force Non Greaseable</i>	UJ269		<i>Brute Force Non Greaseable</i>	UJ269
	(For Aluminum Drive Shaft)	UJ369C		(For Aluminum Drive Shaft)	UJ369C
	U-Bolt Kit (Rear)	UJ329-10		U-Bolt Kit (Rear)	UJ329-10
1970	C10, C15 & Suburban w/ 2 Joint Shaft & Auto. Trans. Exc. THM400: [Type 2]		1969-1968 C10 & C15 w/ 3 Joint Shaft & 4 Spd. Man. Trans. Exc. 396 Eng.: [Type 2]		
	U-Joint (Front)Ⓢ	UJ369		U-Joint (Front)Ⓢ	UJ331
	<i>Brute Force Greaseable</i>	UJ280		<i>Brute Force Greaseable</i>	UJ232
	<i>Brute Force Non Greaseable</i>	UJ269		<i>Brute Force Non Greaseable</i>	UJ231
	(For Aluminum Drive Shaft)	UJ369C		(For Aluminum Drive Shaft)	UJ331C
	U-Bolt Kit (Front)	UJ329-10		U-Bolt Kit (Front)	UJ331-10
	U-Joint (Center)Ⓢ	UJ369		U-Joint (Center)Ⓢ	UJ369
	<i>Brute Force Greaseable</i>	UJ280		<i>Brute Force Greaseable</i>	UJ280
	<i>Brute Force Non Greaseable</i>	UJ269		<i>Brute Force Non Greaseable</i>	UJ269
	(For Aluminum Drive Shaft)	UJ369C		(For Aluminum Drive Shaft)	UJ369C
	U-Bolt Kit (Center)	UJ329-10		U-Bolt Kit (Center)	UJ329-10
	U-Joint (Rear)Ⓢ	UJ369		U-Joint (Rear)Ⓢ	UJ369
	<i>Brute Force Greaseable</i>	UJ280		<i>Brute Force Greaseable</i>	UJ280
	<i>Brute Force Non Greaseable</i>	UJ269		<i>Brute Force Non Greaseable</i>	UJ269
	(For Aluminum Drive Shaft)	UJ369C		(For Aluminum Drive Shaft)	UJ369C
	U-Bolt Kit (Rear)	UJ329-10		U-Bolt Kit (Rear)	UJ329-10
1969-1968	C10, C15 & Suburban w/ 3 Joint Shaft, Auto. Trans. & 396 Eng.: [Type 2]				(Continued)
	U-Joint (Front)Ⓢ	UJ354			
	<i>Brute Force Greaseable</i>	UJ270			
	<i>Brute Force Non Greaseable</i>	UJ254			
	(For Aluminum Drive Shaft)	UJ354C			
	U-Bolt Kit (Front)	UJ329-10			
	U-Joint (Center)Ⓢ	UJ331			
	<i>Brute Force Greaseable</i>	UJ232			
	<i>Brute Force Non Greaseable</i>	UJ231			
	(For Aluminum Drive Shaft)	UJ331C			
	U-Bolt Kit (Center)	UJ330-10			
	U-Joint (Rear)Ⓢ	UJ354			
	<i>Brute Force Greaseable</i>	UJ270			
	<i>Brute Force Non Greaseable</i>	UJ254			
	(For Aluminum Drive Shaft)	UJ354C			
	U-Bolt Kit (Rear)	UJ329-10			

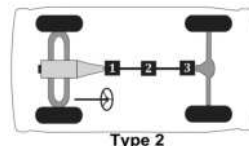

Passenger cars, light & medium trucks

Chevrolet/GMC Truck 1/2 ton -- (Cont.)

MFG./YEAR	MODEL & LOCATION	PART NO.	MFG./YEAR	MODEL & LOCATION	PART NO.
-----------	------------------	----------	-----------	------------------	----------

Drive Shaft (2 W/D) (Cont.)

U-Joint (Cont.)

1969-1968 C10 & C15 w/ 3 Joint Shaft, 4 Spd.

Man. Trans. & 396 Eng.: [Type 2]

U-Joint (Front)Ⓚ	UJ331
Brute Force Greaseable	UJ232
Brute Force Non Greaseable	UJ231
(For Aluminum Drive Shaft)	UJ331C
U-Bolt Kit (Front)	UJ330-10
U-Joint (Center)Ⓚ	UJ331
Brute Force Greaseable	UJ232
Brute Force Non Greaseable	UJ231
(For Aluminum Drive Shaft)	UJ331C
U-Bolt Kit (Center)	UJ330-10
U-Joint (Rear)Ⓚ	UJ331
Brute Force Greaseable	UJ232
Brute Force Non Greaseable	UJ231
(For Aluminum Drive Shaft)	UJ331C
U-Bolt Kit (Rear)	UJ330-10

1967 C10 & C15 w/ 3 Joint Shaft & Auto.

Trans.: [Type 2]

U-Joint (Front)Ⓚ	UJ369
Brute Force Greaseable	UJ280
Brute Force Non Greaseable	UJ269
(For Aluminum Drive Shaft)	UJ369C
U-Bolt Kit (Front)	UJ329-10
U-Joint (Center)Ⓚ	UJ369
Brute Force Greaseable	UJ280
Brute Force Non Greaseable	UJ269
(For Aluminum Drive Shaft)	UJ369C
U-Bolt Kit (Center)	UJ329-10
U-Joint (Rear)Ⓚ	UJ369
Brute Force Greaseable	UJ280
Brute Force Non Greaseable	UJ269
(For Aluminum Drive Shaft)	UJ369C
U-Bolt Kit (Rear)	UJ329-10

1967 C10 & C15 w/ 3 Joint Shaft & 4 Spd.

Man. Trans.: [Type 2]

U-Joint (Front)Ⓚ	UJ331
Brute Force Greaseable	UJ232
Brute Force Non Greaseable	UJ231
(For Aluminum Drive Shaft)	UJ331C
U-Joint (Center)Ⓚ	UJ369
Brute Force Greaseable	UJ280
Brute Force Non Greaseable	UJ269
(For Aluminum Drive Shaft)	UJ369C
U-Bolt Kit (Center)	UJ329-10
U-Joint (Rear)Ⓚ	UJ369
Brute Force Greaseable	UJ280
Brute Force Non Greaseable	UJ269
(For Aluminum Drive Shaft)	UJ369C
U-Bolt Kit (Rear)	UJ329-10

Drive Shaft (4 W/D)

U-Joint

2020-2015 Suburban & Yukon XL: [Type 13]

U-Joint (Fr. Shaft; Fr.)Ⓚ	UJ534G
Brute Force Greaseable	UJ235
Brute Force Non Greaseable	UJ234
Clamp Kit (Fr. Shaft; Fr.)	UJ530-10
U-Joint (Fr. Shaft; Rr.)Ⓚ	UJ534G
Brute Force Greaseable	UJ235
Brute Force Non Greaseable	UJ234
Clamp Kit (Fr. Shaft; Rr.)	UJ530-10
U-Joint (Rr. Shaft; Fr.)Ⓚ	UJ330
Brute Force Greaseable	UJ295
(For Aluminum Drive Shaft)	UJ330C
U-Joint (Rr. Shaft; Rr.)Ⓚ	UJ330
Brute Force Greaseable	UJ295
(For Aluminum Drive Shaft)	UJ330C

2020-2015 Tahoe & Yukon Exc. XL: [Type 13]

U-Joint (Fr. Shaft; Fr.)Ⓚ	UJ534G
Brute Force Greaseable	UJ235
Brute Force Non Greaseable	UJ234
Clamp Kit (Fr. Shaft; Fr.)	UJ530-10
U-Joint (Fr. Shaft; Rr.)Ⓚ	UJ534G
Brute Force Greaseable	UJ235
Brute Force Non Greaseable	UJ234
Clamp Kit (Fr. Shaft; Rr.)	UJ530-10
U-Joint (Rr. Shaft; Fr.)Ⓚ	UJ331
Brute Force Greaseable	UJ232
Brute Force Non Greaseable	UJ231
(For Aluminum Drive Shaft)	UJ331C
U-Joint (Rr. Shaft; Rr.)Ⓚ	UJ331
Brute Force Greaseable	UJ232
Brute Force Non Greaseable	UJ231
(For Aluminum Drive Shaft)	UJ331C

2020-2014 Silverado & Sierra: [Type 13]

U-Joint (Fr. Shaft; Fr.)Ⓚ	UJ534G
Brute Force Greaseable	UJ235
Brute Force Non Greaseable	UJ234
Clamp Kit (Fr. Shaft; Fr.)	UJ530-10
U-Joint (Fr. Shaft; Rr.)Ⓚ	UJ534G
Brute Force Greaseable	UJ235
Brute Force Non Greaseable	UJ234
Clamp Kit (Fr. Shaft; Rr.)	UJ530-10
U-Joint (Rr. Shaft; Fr.)Ⓚ	UJ330
Brute Force Greaseable	UJ295
(For Aluminum Drive Shaft)	UJ330C
U-Joint (Rr. Shaft; Rr.)Ⓚ	UJ330
Brute Force Greaseable	UJ295
(For Aluminum Drive Shaft)	UJ330C

(Continued)

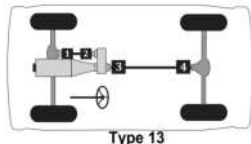

Type 13

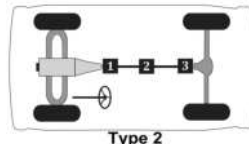

Type 2

Passenger cars, light & medium trucks

(Cont.) -- Chevrolet/GMC Truck 1/2 ton

MFG./YEAR	MODEL & LOCATION	PART NO.	MFG./YEAR	MODEL & LOCATION	PART NO.
Drive Shaft (4 W/D) (Cont.)			Drive Shaft (4 W/D) (Cont.)		
U-Joint (Cont.)			U-Joint (Cont.)		
2014-2009 Tahoe & Yukon: [Type 13]			2008 Tahoe & Yukon w/ Hybrid Eng.: [Type 13]		
	U-Joint (Fr. Shaft; Frt.) ①	UJ534G		U-Joint (Fr. Shaft; Frt.) ①	UJ534G
	<i>Brute Force Greaseable</i>	UJ235		<i>Brute Force Greaseable</i>	UJ235
	<i>Brute Force Non Greaseable</i>	UJ234		<i>Brute Force Non Greaseable</i>	UJ234
	Clamp Kit (Fr. Shaft; Frt.)	UJ530-10		Clamp Kit (Fr. Shaft; Frt.)	UJ530-10
	U-Joint (Fr. Shaft; Rr.) ②	UJ534G		U-Joint (Fr. Shaft; Rr.) ②	UJ534G
	<i>Brute Force Greaseable</i>	UJ235		<i>Brute Force Greaseable</i>	UJ235
	<i>Brute Force Non Greaseable</i>	UJ234		<i>Brute Force Non Greaseable</i>	UJ234
	Clamp Kit (Fr. Shaft; Rr.)	UJ530-10		Clamp Kit (Fr. Shaft; Rr.)	UJ530-10
	U-Joint (Rr. Shaft; Frt.) ③	UJ331A		U-Joint (Rr. Shaft; Frt.) ③	UJ331A
	<i>Brute Force Greaseable</i>	UJ232A		<i>Brute Force Greaseable</i>	UJ232A
	Clamp Kit (Rr. Shaft; Frt.)	UJ492-10		Clamp Kit (Rr. Shaft; Frt.)	UJ492-10
	U-Joint (Rr. Shaft; Rr.) ④	UJ331A		U-Joint (Rr. Shaft; Rr.) ④	UJ331A
	<i>Brute Force Greaseable</i>	UJ232A		<i>Brute Force Greaseable</i>	UJ232A
	Clamp Kit (Rr. Shaft; Rr.)	UJ492-10		Clamp Kit (Rr. Shaft; Rr.)	UJ492-10
2014-2009 Avalanche, Suburban & Yukon XL: [Type 13]			2008 Tahoe & Yukon w/o Hybrid Eng.: [Type 13]		
	U-Joint (Fr. Shaft; Frt.) ①	UJ534G		U-Joint (Fr. Shaft; Frt.) ①	UJ534G
	<i>Brute Force Greaseable</i>	UJ235		<i>Brute Force Greaseable</i>	UJ235
	<i>Brute Force Non Greaseable</i>	UJ234		<i>Brute Force Non Greaseable</i>	UJ234
	Clamp Kit (Fr. Shaft; Frt.)	UJ530-10		Clamp Kit (Fr. Shaft; Frt.)	UJ530-10
	U-Joint (Fr. Shaft; Rr.) ②	UJ534G		U-Joint (Fr. Shaft; Rr.) ②	UJ534G
	<i>Brute Force Greaseable</i>	UJ235		<i>Brute Force Greaseable</i>	UJ235
	<i>Brute Force Non Greaseable</i>	UJ234		<i>Brute Force Non Greaseable</i>	UJ234
	Clamp Kit (Fr. Shaft; Rr.)	UJ530-10		Clamp Kit (Fr. Shaft; Rr.)	UJ530-10
	U-Joint (Rr. Shaft; Frt.) ③	UJ331A		U-Joint (Rr. Shaft; Frt.) ③	UJ331A
	<i>Brute Force Greaseable</i>	UJ232A		<i>Brute Force Greaseable</i>	UJ232A
	Clamp Kit (Rr. Shaft; Frt.)	UJ492-10		Clamp Kit (Rr. Shaft; Frt.)	UJ492-10
	U-Joint (Rr. Shaft; Rr.) ④	UJ331A		U-Joint (Rr. Shaft; Rr.) ④	UJ331A
	<i>Brute Force Greaseable</i>	UJ232A		<i>Brute Force Greaseable</i>	UJ232A
	Clamp Kit (Rr. Shaft; Rr.)	UJ492-10		Clamp Kit (Rr. Shaft; Rr.)	UJ492-10
2013-2008 Silverado & Sierra: [Type 13]			2008 Tahoe & Yukon w/o Hybrid Eng.: [Type 13]		
	U-Joint (Fr. Shaft; Frt.) ①	UJ534G		U-Joint (Fr. Shaft; Frt.) ①	UJ534G
	<i>Brute Force Greaseable</i>	UJ235		<i>Brute Force Greaseable</i>	UJ235
	<i>Brute Force Non Greaseable</i>	UJ234		<i>Brute Force Non Greaseable</i>	UJ234
	Clamp Kit (Fr. Shaft; Frt.)	UJ530-10		Clamp Kit (Fr. Shaft; Frt.)	UJ530-10
	U-Joint (Fr. Shaft; Rr.) ②	UJ534G		U-Joint (Fr. Shaft; Rr.) ②	UJ534G
	<i>Brute Force Greaseable</i>	UJ235		<i>Brute Force Greaseable</i>	UJ235
	<i>Brute Force Non Greaseable</i>	UJ234		<i>Brute Force Non Greaseable</i>	UJ234
	Clamp Kit (Fr. Shaft; Rr.)	UJ530-10		Clamp Kit (Fr. Shaft; Rr.)	UJ530-10
	U-Joint (Rr. Shaft; Frt.) ③	UJ331A		U-Joint (Rr. Shaft; Frt.) ③	UJ331A
	<i>Brute Force Greaseable</i>	UJ232A		<i>Brute Force Greaseable</i>	UJ232A
	Clamp Kit (Rr. Shaft; Frt.)	UJ492-10		Clamp Kit (Rr. Shaft; Frt.)	UJ492-10
	U-Joint (Rr. Shaft; Rr.) ④	UJ331A		U-Joint (Rr. Shaft; Rr.) ④	UJ331A
	<i>Brute Force Greaseable</i>	UJ232A		<i>Brute Force Greaseable</i>	UJ232A
	Clamp Kit (Rr. Shaft; Rr.)	UJ492-10		Clamp Kit (Rr. Shaft; Rr.)	UJ492-10

(Continued)

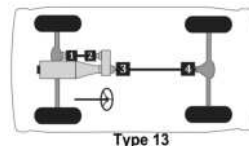

Passenger cars, light & medium trucks

Chevrolet/GMC Truck 1/2 ton -- (Cont.)

MFG./YEAR	MODEL & LOCATION	PART NO.	MFG./YEAR	MODEL & LOCATION	PART NO.
Drive Shaft (4 W/D) (Cont.)			Drive Shaft (4 W/D) (Cont.)		
U-Joint (Cont.)			U-Joint (Cont.)		
2008-2007 Avalanche, Suburban & Yukon XL w/ 5.3L Eng.: [Type 13]			2007 Silverado & Sierra Classic w/ Reg. Cab: [Type 13]		
U-Joint (Fr. Shaft; Frt.)⊙		UJ534G	U-Joint (Fr. Shaft; Frt.)⊙		UJ534G
Brute Force Greaseable		UJ235	Brute Force Greaseable		UJ235
Brute Force Non Greaseable		UJ234	Brute Force Non Greaseable		UJ234
Clamp Kit (Fr. Shaft; Frt.)		UJ530-10	Clamp Kit (Fr. Shaft; Frt.)		UJ530-10
U-Joint (Fr. Shaft; Rr.)⊙		UJ534G	U-Joint (Fr. Shaft; Rr.)⊙		UJ534G
Brute Force Greaseable		UJ235	Brute Force Greaseable		UJ235
Brute Force Non Greaseable		UJ234	Brute Force Non Greaseable		UJ234
Clamp Kit (Fr. Shaft; Rr.)		UJ530-10	Clamp Kit (Fr. Shaft; Rr.)		UJ530-10
U-Joint (Rr. Shaft; Frt.)⊙		UJ534G	U-Joint (Rr. Shaft; Frt.)⊙		UJ331A
Brute Force Greaseable		UJ235	Brute Force Greaseable		UJ232A
Brute Force Non Greaseable		UJ234	Clamp Kit (Rr. Shaft; Frt.)		UJ492-10
Clamp Kit (Rr. Shaft; Frt.)		UJ530-10	U-Joint (Rr. Shaft; Rr.)⊙		UJ331A
U-Joint (Rr. Shaft; Rr.)⊙		UJ534G	Brute Force Greaseable		UJ232A
Brute Force Greaseable		UJ235	Clamp Kit (Rr. Shaft; Rr.)		UJ492-10
Brute Force Non Greaseable		UJ234	2007 Silverado & Sierra Classic w/ Ext. Cab & Std. Bed: [Type 13]		
Clamp Kit (Rr. Shaft; Rr.)		UJ530-10	U-Joint (Fr. Shaft; Frt.)⊙		UJ534G
2008-2007 Avalanche, Suburban & Yukon XL w/ 6.0L Eng.: [Type 13]			Brute Force Greaseable		UJ235
U-Joint (Fr. Shaft; Frt.)⊙		UJ534G	Brute Force Non Greaseable		UJ234
Brute Force Greaseable		UJ235	Clamp Kit (Fr. Shaft; Frt.)		UJ530-10
Brute Force Non Greaseable		UJ234	U-Joint (Fr. Shaft; Rr.)⊙		UJ534G
Clamp Kit (Fr. Shaft; Frt.)		UJ530-10	Brute Force Greaseable		UJ235
U-Joint (Fr. Shaft; Rr.)⊙		UJ534G	Brute Force Non Greaseable		UJ234
Brute Force Greaseable		UJ235	Clamp Kit (Fr. Shaft; Rr.)		UJ530-10
Brute Force Non Greaseable		UJ234	U-Joint (Rr. Shaft; Frt.)⊙		UJ331
Clamp Kit (Fr. Shaft; Rr.)		UJ530-10	Brute Force Greaseable		UJ232
U-Joint (Rr. Shaft; Frt.)⊙		UJ331A	Brute Force Non Greaseable		UJ231
Brute Force Greaseable		UJ232A	(For Aluminum Drive Shaft)		UJ331C
Clamp Kit (Rr. Shaft; Frt.)		UJ492-10	Clamp Kit (Rr. Shaft; Frt.)		UJ492-10
U-Joint (Rr. Shaft; Rr.)⊙		UJ331A	U-Joint (Rr. Shaft; Rr.)⊙		UJ331
Brute Force Greaseable		UJ232A	Brute Force Greaseable		UJ232
Clamp Kit (Rr. Shaft; Rr.)		UJ492-10	Brute Force Non Greaseable		UJ231
2007 Silverado & Sierra Exc. Classic: [Type 13]			(For Aluminum Drive Shaft)		UJ331C
U-Joint (Fr. Shaft; Frt.)⊙		UJ534G	Clamp Kit (Rr. Shaft; Rr.)		UJ492-10
Brute Force Greaseable		UJ235			(Continued)
Brute Force Non Greaseable		UJ234			
Clamp Kit (Fr. Shaft; Frt.)		UJ530-10			
U-Joint (Fr. Shaft; Rr.)⊙		UJ534G			
Brute Force Greaseable		UJ235			
Brute Force Non Greaseable		UJ234			
Clamp Kit (Fr. Shaft; Rr.)		UJ530-10			
U-Joint (Rr. Shaft; Frt.)⊙		UJ331A			
Brute Force Greaseable		UJ232A			
Clamp Kit (Rr. Shaft; Frt.)		UJ492-10			
U-Joint (Rr. Shaft; Rr.)⊙		UJ331A			
Brute Force Greaseable		UJ232A			
Clamp Kit (Rr. Shaft; Rr.)		UJ492-10			

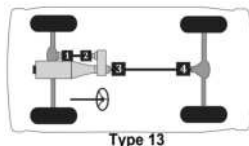

Passenger cars, light & medium trucks

(Cont.) -- Chevrolet/GMC Truck 1/2 ton

MFG./YEAR	MODEL & LOCATION	PART NO.	MFG./YEAR	MODEL & LOCATION	PART NO.
Drive Shaft (4 W/D) (Cont.)			Drive Shaft (4 W/D) (Cont.)		
U-Joint (Cont.)			U-Joint (Cont.)		
2007	Silverado & Sierra Classic w/ Ext. Cab & Long Bed: [Type 14]		2007-1995	Tahoe & Yukon: [Type 13]	
	U-Joint (Frnt. Shaft; Frt.) ①	UJ534G		U-Joint (Frnt. Shaft; Frt.) ①	UJ534G
	Brute Force Greaseable	UJ235		Brute Force Greaseable	UJ235
	Brute Force Non Greaseable	UJ234		Brute Force Non Greaseable	UJ234
	Clamp Kit (Frnt. Shaft; Frt.)	UJ530-10		Clamp Kit (Frnt. Shaft; Frt.)	UJ530-10
	U-Joint (Frnt. Shaft; Rr.) ②	UJ534G		U-Joint (Frnt. Shaft; Rr.) ②	UJ534G
	Brute Force Greaseable	UJ235		Brute Force Greaseable	UJ235
	Brute Force Non Greaseable	UJ234		Brute Force Non Greaseable	UJ234
	Clamp Kit (Frnt. Shaft; Rr.)	UJ530-10		Clamp Kit (Frnt. Shaft; Rr.)	UJ530-10
	U-Joint (Rr. Shaft; Frt.) ③	UJ331		U-Joint (Rr. Shaft; Frt.) ③	UJ331
	Brute Force Greaseable	UJ232		Brute Force Greaseable	UJ232
	Brute Force Non Greaseable	UJ231		Brute Force Non Greaseable	UJ231
	(For Aluminum Drive Shaft)	UJ331C		Clamp Kit (Rr. Shaft; Frt.)	UJ530-10
	Clamp Kit (Rr. Shaft; Frt.)	UJ492-10		U-Joint (Rr. Shaft; Rr.) ④	UJ534G
	U-Joint (Rr. Shaft; Ctr.) ④	UJ331		Brute Force Greaseable	UJ235
	Brute Force Greaseable	UJ232		Brute Force Non Greaseable	UJ234
	Brute Force Non Greaseable	UJ231		Clamp Kit (Rr. Shaft; Rr.)	UJ530-10
	(For Aluminum Drive Shaft)	UJ331C		2006 Silverado & Sierra w/ Reg. Cab:	
	Clamp Kit (Rr. Shaft; Ctr.)	UJ492-10		[Type 13]	
	U-Joint (Rr. Shaft; Rr.) ⑤	UJ331		U-Joint (Frnt. Shaft; Frt.) ①	UJ534G
	Brute Force Greaseable	UJ232		Brute Force Greaseable	UJ235
	Brute Force Non Greaseable	UJ231		Brute Force Non Greaseable	UJ234
	(For Aluminum Drive Shaft)	UJ331C		Clamp Kit (Frnt. Shaft; Frt.)	UJ530-10
	Clamp Kit (Rr. Shaft; Rr.)	UJ492-10		U-Joint (Frnt. Shaft; Rr.) ②	UJ534G
2007	Silverado & Sierra Classic w/ Crew Cab: [Type 13]			Brute Force Greaseable	UJ235
	U-Joint (Frnt. Shaft; Frt.) ①	UJ534G		Brute Force Non Greaseable	UJ234
	Brute Force Greaseable	UJ235		Clamp Kit (Frnt. Shaft; Rr.)	UJ530-10
	Brute Force Non Greaseable	UJ234		U-Joint (Rr. Shaft; Frt.) ③	UJ331A
	Clamp Kit (Frnt. Shaft; Frt.)	UJ530-10		Brute Force Greaseable	UJ232A
	U-Joint (Frnt. Shaft; Rr.) ②	UJ534G		Clamp Kit (Rr. Shaft; Frt.)	UJ492-10
	Brute Force Greaseable	UJ235		U-Joint (Rr. Shaft; Rr.) ④	UJ331A
	Brute Force Non Greaseable	UJ234		Brute Force Greaseable	UJ232A
	Clamp Kit (Frnt. Shaft; Rr.)	UJ530-10		Clamp Kit (Rr. Shaft; Rr.)	UJ492-10
	U-Joint (Rr. Shaft; Frt.) ③	UJ331			(Continued)
	Brute Force Greaseable	UJ232			
	Brute Force Non Greaseable	UJ231			
	(For Aluminum Drive Shaft)	UJ331C			
	Clamp Kit (Rr. Shaft; Frt.)	UJ492-10			
	U-Joint (Rr. Shaft; Rr.) ④	UJ331			
	Brute Force Greaseable	UJ232			
	Brute Force Non Greaseable	UJ231			
	(For Aluminum Drive Shaft)	UJ331C			
	Clamp Kit (Rr. Shaft; Rr.)	UJ492-10			

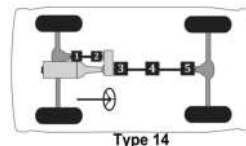
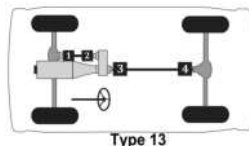

Passenger cars, light & medium trucks

Chevrolet/GMC Truck 1/2 ton -- (Cont.)

MFG./YEAR	MODEL & LOCATION	PART NO.	MFG./YEAR	MODEL & LOCATION	PART NO.
Drive Shaft (4 W/D) (Cont.)			Drive Shaft (4 W/D) (Cont.)		
U-Joint (Cont.)			U-Joint (Cont.)		
2006	Silverado & Sierra Classic w/ Ext. Cab & Std. Bed: [Type 13]		2006	Silverado & Sierra Crew Cab: [Type 13]	
	U-Joint (Fr. Shaft; Frt.) [⊙]	UJ534G		U-Joint (Fr. Shaft; Frt.) [⊙]	UJ534G
	Brute Force Greaseable	UJ235		Brute Force Greaseable	UJ235
	Brute Force Non Greaseable	UJ234		Brute Force Non Greaseable	UJ234
	Clamp Kit (Fr. Shaft; Frt.)	UJ530-10		Clamp Kit (Fr. Shaft; Frt.)	UJ530-10
	U-Joint (Fr. Shaft; Rr.) [⊙]	UJ534G		U-Joint (Fr. Shaft; Rr.) [⊙]	UJ534G
	Brute Force Greaseable	UJ235		Brute Force Greaseable	UJ235
	Brute Force Non Greaseable	UJ234		Brute Force Non Greaseable	UJ234
	Clamp Kit (Fr. Shaft; Rr.)	UJ530-10		Clamp Kit (Fr. Shaft; Rr.)	UJ530-10
	U-Joint (Rr. Shaft; Frt.) [⊙]	UJ331		U-Joint (Rr. Shaft; Frt.) [⊙]	UJ331
	Brute Force Greaseable	UJ232		Brute Force Greaseable	UJ232
	Brute Force Non Greaseable	UJ231		Brute Force Non Greaseable	UJ231
	(For Aluminum Drive Shaft)	UJ331C		Brute Force Non Greaseable	UJ231
	Clamp Kit (Rr. Shaft; Frt.)	UJ492-10		(For Aluminum Drive Shaft)	UJ331C
	U-Joint (Rr. Shaft; Rr.) [⊙]	UJ331		Clamp Kit (Rr. Shaft; Frt.)	UJ492-10
	Brute Force Greaseable	UJ232		U-Joint (Rr. Shaft; Rr.) [⊙]	UJ331
	Brute Force Non Greaseable	UJ231		Brute Force Greaseable	UJ232
	(For Aluminum Drive Shaft)	UJ331C		Brute Force Non Greaseable	UJ231
	Clamp Kit (Rr. Shaft; Rr.)	UJ492-10		Brute Force Non Greaseable	UJ231
	2006 Silverado & Sierra w/ Ext. Cab & Long Bed: [Type 14]			(For Aluminum Drive Shaft)	UJ331C
	U-Joint (Fr. Shaft; Frt.) [⊙]	UJ534G		Clamp Kit (Rr. Shaft; Rr.)	UJ492-10
	Brute Force Greaseable	UJ235		2006-2001 Avalanche, Suburban & Yukon XL: [Type 13]	
	Brute Force Non Greaseable	UJ234		U-Joint (Fr. Shaft; Frt.) [⊙]	UJ534G
	Clamp Kit (Fr. Shaft; Frt.)	UJ530-10		Brute Force Greaseable	UJ235
	U-Joint (Fr. Shaft; Rr.) [⊙]	UJ534G		Brute Force Non Greaseable	UJ234
	Brute Force Greaseable	UJ235		Clamp Kit (Fr. Shaft; Frt.)	UJ530-10
	Brute Force Non Greaseable	UJ234		U-Joint (Fr. Shaft; Rr.) [⊙]	UJ534G
	Clamp Kit (Fr. Shaft; Rr.)	UJ530-10		Brute Force Greaseable	UJ235
	Clamp Kit (Fr. Shaft; Rr.)	UJ530-10		Brute Force Non Greaseable	UJ234
	U-Joint (Rr. Shaft; Frt.) [⊙]	UJ331		Clamp Kit (Fr. Shaft; Rr.)	UJ530-10
	Brute Force Greaseable	UJ232		U-Joint (Rr. Shaft; Frt.) [⊙]	UJ534G
	Brute Force Non Greaseable	UJ231		Brute Force Greaseable	UJ235
	(For Aluminum Drive Shaft)	UJ331C		Brute Force Non Greaseable	UJ234
	Clamp Kit (Rr. Shaft; Frt.)	UJ492-10		Clamp Kit (Fr. Shaft; Rr.)	UJ530-10
	U-Joint (Rr. Shaft; Ctr.) [⊙]	UJ331		U-Joint (Rr. Shaft; Rr.) [⊙]	UJ534G
	Brute Force Greaseable	UJ232		Brute Force Greaseable	UJ235
	Brute Force Non Greaseable	UJ231		Brute Force Non Greaseable	UJ234
	(For Aluminum Drive Shaft)	UJ331C		Clamp Kit (Rr. Shaft; Rr.)	UJ530-10
	Clamp Kit (Rr. Shaft; Frt.)	UJ492-10			(Continued)
	U-Joint (Rr. Shaft; Rr.) [⊙]	UJ331			
	Brute Force Greaseable	UJ232			
	Brute Force Non Greaseable	UJ231			
	(For Aluminum Drive Shaft)	UJ331C			
	Clamp Kit (Rr. Shaft; Rr.)	UJ492-10			

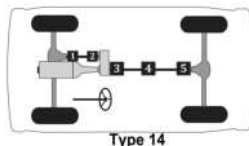
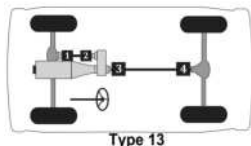

Passenger cars, light & medium trucks

(Cont.) -- Chevrolet/GMC Truck 1/2 ton

MFG./YEAR	MODEL & LOCATION	PART NO.	MFG./YEAR	MODEL & LOCATION	PART NO.
Drive Shaft (4 W/D) (Cont.)			Drive Shaft (4 W/D) (Cont.)		
U-Joint (Cont.)			U-Joint (Cont.)		
2005	Silverado & Sierra w/ Reg. Cab & Inne Lock Rings: [Type 13]		2005	Silverado & Sierra w/ Ext. Cab, Std. Bed & 1.1875" OD Brgs. Exc. SS & Quadrasteer: [Type 13]	
	U-Joint (Frnt. Shaft; Frnt.)ⓐ	UJ534G		U-Joint (Frnt. Shaft; Frnt.)ⓐ	UJ534G
	Brute Force Greaseable	UJ235		Brute Force Greaseable	UJ235
	Brute Force Non Greaseable	UJ234		Brute Force Non Greaseable	UJ234
	Clamp Kit (Frnt. Shaft; Frnt.)	UJ530-10		Clamp Kit (Frnt. Shaft; Frnt.)	UJ530-10
	U-Joint (Frnt. Shaft; Rr.)ⓑ	UJ534G		U-Joint (Frnt. Shaft; Rr.)ⓑ	UJ534G
	Brute Force Greaseable	UJ235		Brute Force Greaseable	UJ235
	Brute Force Non Greaseable	UJ234		Brute Force Non Greaseable	UJ234
	Clamp Kit (Frnt. Shaft; Rr.)	UJ530-10		Clamp Kit (Frnt. Shaft; Rr.)	UJ530-10
	U-Joint (Rr. Shaft; Frnt.)ⓐ	UJ534G		U-Joint (Rr. Shaft; Frnt.)ⓐ	UJ331
	Brute Force Greaseable	UJ235		Brute Force Greaseable	UJ232
	Brute Force Non Greaseable	UJ234		Brute Force Non Greaseable	UJ231
	Clamp Kit (Rr. Shaft; Frnt.)	UJ530-10		(For Aluminum Drive Shaft)	UJ331C
	U-Joint (Rr. Shaft; Rr.)ⓑ	UJ534G		Clamp Kit (Rr. Shaft; Frnt.)	UJ492-10
	Brute Force Greaseable	UJ235		U-Joint (Rr. Shaft; Rr.)ⓑ	UJ331
	Brute Force Non Greaseable	UJ234		Brute Force Greaseable	UJ232
	Clamp Kit (Rr. Shaft; Rr.)	UJ530-10		Brute Force Non Greaseable	UJ231
2005	Silverado & Sierra w/ Reg. Cab & Outer Lock Rings: [Type 13]		2005	Silverado & Sierra w/ Ext. Cab, Std. Bed & 1.0625" OD Brgs. Exc. SS & Quadrasteer: [Type 13]	
	U-Joint (Frnt. Shaft; Frnt.)ⓐ	UJ534G		U-Joint (Frnt. Shaft; Frnt.)ⓐ	UJ534G
	Brute Force Greaseable	UJ235		Brute Force Greaseable	UJ235
	Brute Force Non Greaseable	UJ234		Brute Force Non Greaseable	UJ234
	Clamp Kit (Frnt. Shaft; Frnt.)	UJ530-10		Clamp Kit (Frnt. Shaft; Frnt.)	UJ530-10
	U-Joint (Frnt. Shaft; Rr.)ⓑ	UJ534G		U-Joint (Frnt. Shaft; Rr.)ⓑ	UJ534G
	Brute Force Greaseable	UJ235		Brute Force Greaseable	UJ235
	Brute Force Non Greaseable	UJ234		Brute Force Non Greaseable	UJ234
	Clamp Kit (Frnt. Shaft; Rr.)	UJ530-10		Clamp Kit (Frnt. Shaft; Rr.)	UJ530-10
	U-Joint (Rr. Shaft; Frnt.)ⓐ	UJ331A		U-Joint (Rr. Shaft; Frnt.)ⓐ	UJ354
	Brute Force Greaseable	UJ232A		Brute Force Greaseable	UJ270
	Clamp Kit (Rr. Shaft; Frnt.)	UJ492-10		Brute Force Non Greaseable	UJ254
	U-Joint (Rr. Shaft; Rr.)ⓑ	UJ331A		(For Aluminum Drive Shaft)	UJ354C
	Brute Force Greaseable	UJ232A		U-Joint (Rr. Shaft; Rr.)ⓑ	UJ355
	Clamp Kit (Rr. Shaft; Rr.)	UJ492-10		Brute Force Greaseable	UJ290
				(For Aluminum Drive Shaft)	UJ355C
				Clamp Kit (Rr. Shaft; Rr.)	UJ530-10

(Continued)

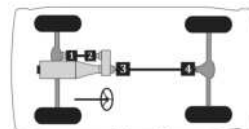

Type 13

Passenger cars, light & medium trucks

Chevrolet/GMC Truck 1/2 ton -- (Cont.)

MFG./YEAR	MODEL & LOCATION	PART NO.	MFG./YEAR	MODEL & LOCATION	PART NO.
-----------	------------------	----------	-----------	------------------	----------

Drive Shaft (4 W/D) (Cont.)

U-Joint (Cont.)

2005	Silverado & Sierra w/ Ext. Cab, Long Bed & 1.0625" OD Brgs. Exc. SS & Quadrasteer: [Type 14]	
	U-Joint (Fr. Shaft; Frt.) ⊙	UJ534G
	<i>Brute Force Greaseable</i>	<i>UJ235</i>
	<i>Brute Force Non Greaseable</i>	<i>UJ234</i>
	Clamp Kit (Fr. Shaft; Frt.)	UJ530-10
	U-Joint (Fr. Shaft; Rr.) ⊙	UJ534G
	<i>Brute Force Greaseable</i>	<i>UJ235</i>
	<i>Brute Force Non Greaseable</i>	<i>UJ234</i>
	Clamp Kit (Fr. Shaft; Rr.)	UJ530-10
	U-Joint (Rr. Shaft; Frt.) ⊙	UJ354
	<i>Brute Force Greaseable</i>	<i>UJ270</i>
	<i>Brute Force Non Greaseable</i>	<i>UJ254</i>
	(For Aluminum Drive Shaft)	UJ354C
	U-Joint (Rr. Shaft; Ctr.) ⊙	UJ354
	<i>Brute Force Greaseable</i>	<i>UJ270</i>
	<i>Brute Force Non Greaseable</i>	<i>UJ254</i>
	(For Aluminum Drive Shaft)	UJ354C
	U-Joint (Rr. Shaft; Rr.) ⊙	UJ355
	<i>Brute Force Greaseable</i>	<i>UJ290</i>
	(For Aluminum Drive Shaft)	UJ355C
	Clamp Kit (Rr. Shaft; Rr.)	UJ530-10
2005	Silverado & Sierra w/ Ext. Cab, Long Bed & 1.1875" OD Brgs. Exc. SS & Quadrasteer: [Type 14]	
	U-Joint (Fr. Shaft; Frt.) ⊙	UJ534G
	<i>Brute Force Greaseable</i>	<i>UJ235</i>
	<i>Brute Force Non Greaseable</i>	<i>UJ234</i>
	Clamp Kit (Fr. Shaft; Frt.)	UJ530-10
	U-Joint (Fr. Shaft; Rr.) ⊙	UJ534G
	<i>Brute Force Greaseable</i>	<i>UJ235</i>
	<i>Brute Force Non Greaseable</i>	<i>UJ234</i>
	Clamp Kit (Fr. Shaft; Rr.)	UJ530-10
	U-Joint (Rr. Shaft; Frt.) ⊙	UJ331
	<i>Brute Force Greaseable</i>	<i>UJ232</i>
	<i>Brute Force Non Greaseable</i>	<i>UJ231</i>
	(For Aluminum Drive Shaft)	UJ331C
	Clamp Kit (Rr. Shaft; Frt.)	UJ492-10
	U-Joint (Rr. Shaft; Ctr.) ⊙	UJ331
	<i>Brute Force Greaseable</i>	<i>UJ232</i>
	<i>Brute Force Non Greaseable</i>	<i>UJ231</i>
	(For Aluminum Drive Shaft)	UJ331C
	Clamp Kit (Rr. Shaft; Ctr.)	UJ492-10
	U-Joint (Rr. Shaft; Rr.) ⊙	UJ331
	<i>Brute Force Greaseable</i>	<i>UJ232</i>
	<i>Brute Force Non Greaseable</i>	<i>UJ231</i>
	(For Aluminum Drive Shaft)	UJ331C
	Clamp Kit (Rr. Shaft; Rr.)	UJ492-10

Drive Shaft (4 W/D) (Cont.)

U-Joint (Cont.)

2005	Silverado & Sierra w/ Ext. Cab & Quadrasteer: [Type 13]	
	U-Joint (Fr. Shaft; Frt.) ⊙	UJ534G
	<i>Brute Force Greaseable</i>	<i>UJ235</i>
	<i>Brute Force Non Greaseable</i>	<i>UJ234</i>
	Clamp Kit (Fr. Shaft; Frt.)	UJ530-10
	U-Joint (Fr. Shaft; Rr.) ⊙	UJ534G
	<i>Brute Force Greaseable</i>	<i>UJ235</i>
	<i>Brute Force Non Greaseable</i>	<i>UJ234</i>
	Clamp Kit (Fr. Shaft; Rr.)	UJ530-10
	U-Joint (Rr. Shaft; Frt.) ⊙	UJ331
	<i>Brute Force Greaseable</i>	<i>UJ232</i>
	<i>Brute Force Non Greaseable</i>	<i>UJ231</i>
	(For Aluminum Drive Shaft)	UJ331C
	Clamp Kit (Rr. Shaft; Frt.)	UJ492-10
	U-Joint (Rr. Shaft; Rr.) ⊙	UJ331
	<i>Brute Force Greaseable</i>	<i>UJ232</i>
	<i>Brute Force Non Greaseable</i>	<i>UJ231</i>
	(For Aluminum Drive Shaft)	UJ331C
	Clamp Kit (Rr. Shaft; Rr.)	UJ492-10
2005	Silverado & Sierra w/ Crew Cab & 1.0625" OD Brgs. Exc. Quadrasteer: [Type 13]	
	U-Joint (Fr. Shaft; Frt.) ⊙	UJ534G
	<i>Brute Force Greaseable</i>	<i>UJ235</i>
	<i>Brute Force Non Greaseable</i>	<i>UJ234</i>
	Clamp Kit (Fr. Shaft; Frt.)	UJ530-10
	U-Joint (Fr. Shaft; Rr.) ⊙	UJ534G
	<i>Brute Force Greaseable</i>	<i>UJ235</i>
	<i>Brute Force Non Greaseable</i>	<i>UJ234</i>
	Clamp Kit (Fr. Shaft; Rr.)	UJ530-10
	U-Joint (Rr. Shaft; Frt.) ⊙	UJ354
	<i>Brute Force Greaseable</i>	<i>UJ270</i>
	<i>Brute Force Non Greaseable</i>	<i>UJ254</i>
	(For Aluminum Drive Shaft)	UJ354C
	U-Joint (Rr. Shaft; Rr.) ⊙	UJ355
	<i>Brute Force Greaseable</i>	<i>UJ290</i>
	(For Aluminum Drive Shaft)	UJ355C
	Clamp Kit (Rr. Shaft; Rr.)	UJ530-10

(Continued)

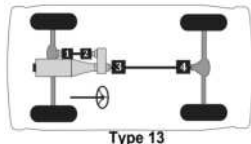

Type 13

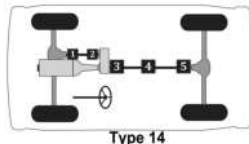

Type 14

SKF

Passenger cars, light & medium trucks

(Cont.) -- Chevrolet/GMC Truck 1/2 ton

MFG./YEAR	MODEL & LOCATION	PART NO.	MFG./YEAR	MODEL & LOCATION	PART NO.
Drive Shaft (4 W/D) (Cont.)			Drive Shaft (4 W/D) (Cont.)		
U-Joint (Cont.)			U-Joint (Cont.)		
2005	Silverado & Sierra w/ Crew Cab & 1.1875" OD Brgs. Exc. Quadrasteer:		2004	Silverado & Sierra w/ Crew Cab:	
	[Type 13]			[Type 13]	
	U-Joint (Fr. Shaft; Fr.) ①	UJ534G	U-Joint (Fr. Shaft; Fr.) ①		UJ534G
	Brute Force Greaseable	UJ235	Brute Force Greaseable		UJ235
	Brute Force Non Greaseable	UJ234	Brute Force Non Greaseable		UJ234
	Clamp Kit (Fr. Shaft; Fr.)	UJ530-10	Clamp Kit (Fr. Shaft; Fr.)		UJ530-10
	U-Joint (Fr. Shaft; Rr.) ②	UJ534G	U-Joint (Fr. Shaft; Rr.) ②		UJ534G
	Brute Force Greaseable	UJ235	Brute Force Greaseable		UJ235
	Brute Force Non Greaseable	UJ234	Brute Force Non Greaseable		UJ234
	Clamp Kit (Fr. Shaft; Rr.)	UJ530-10	Clamp Kit (Fr. Shaft; Rr.)		UJ530-10
	U-Joint (Rr. Shaft; Fr.) ③	UJ331	U-Joint (Rr. Shaft; Fr.) ③		UJ331
	Brute Force Greaseable	UJ232	Brute Force Greaseable		UJ232
	Brute Force Non Greaseable	UJ231	Brute Force Non Greaseable		UJ231
	(For Aluminum Drive Shaft)	UJ331C	(For Aluminum Drive Shaft)		UJ331C
	Clamp Kit (Rr. Shaft; Fr.)	UJ492-10	Clamp Kit (Rr. Shaft; Fr.)		UJ492-10
	U-Joint (Rr. Shaft; Rr.) ④	UJ331	U-Joint (Rr. Shaft; Rr.) ④		UJ331
	Brute Force Greaseable	UJ232	Brute Force Greaseable		UJ232
	Brute Force Non Greaseable	UJ231	Brute Force Non Greaseable		UJ231
	(For Aluminum Drive Shaft)	UJ331C	(For Aluminum Drive Shaft)		UJ331C
	Clamp Kit (Rr. Shaft; Rr.)	UJ492-10	Clamp Kit (Rr. Shaft; Rr.)		UJ492-10
2005	Silverado & Sierra w/ Crew Cab & Quadrasteer: [Type 13]		2004-2002	Silverado & Sierra w/ Reg. Cab:	
	[Type 13]			[Type 13]	
	U-Joint (Fr. Shaft; Fr.) ①	UJ534G	U-Joint (Fr. Shaft; Fr.) ①		UJ534G
	Brute Force Greaseable	UJ235	Brute Force Greaseable		UJ235
	Brute Force Non Greaseable	UJ234	Brute Force Non Greaseable		UJ234
	Clamp Kit (Fr. Shaft; Fr.)	UJ530-10	Clamp Kit (Fr. Shaft; Fr.)		UJ530-10
	U-Joint (Fr. Shaft; Rr.) ②	UJ534G	U-Joint (Fr. Shaft; Rr.) ②		UJ534G
	Brute Force Greaseable	UJ235	Brute Force Greaseable		UJ235
	Brute Force Non Greaseable	UJ234	Brute Force Non Greaseable		UJ234
	Clamp Kit (Fr. Shaft; Rr.)	UJ530-10	Clamp Kit (Fr. Shaft; Rr.)		UJ530-10
	U-Joint (Rr. Shaft; Fr.) ③	UJ331	U-Joint (Rr. Shaft; Fr.) ③		UJ331
	Brute Force Greaseable	UJ232	Brute Force Greaseable		UJ232
	Brute Force Non Greaseable	UJ231	Brute Force Non Greaseable		UJ231
	(For Aluminum Drive Shaft)	UJ331C	(For Aluminum Drive Shaft)		UJ331C
	Clamp Kit (Rr. Shaft; Fr.)	UJ492-10	Clamp Kit (Rr. Shaft; Fr.)		UJ492-10
	U-Joint (Rr. Shaft; Rr.) ④	UJ331	U-Joint (Rr. Shaft; Rr.) ④		UJ331
	Brute Force Greaseable	UJ232	Brute Force Greaseable		UJ232
	Brute Force Non Greaseable	UJ231	Brute Force Non Greaseable		UJ231
	(For Aluminum Drive Shaft)	UJ331C	(For Aluminum Drive Shaft)		UJ331C
	Clamp Kit (Rr. Shaft; Rr.)	UJ492-10	Clamp Kit (Rr. Shaft; Rr.)		UJ492-10

(Continued)

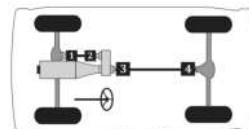

Type 13

Passenger cars, light & medium trucks

Chevrolet/GMC Truck 1/2 ton -- (Cont.)

MFG./YEAR	MODEL & LOCATION	PART NO.	MFG./YEAR	MODEL & LOCATION	PART NO.
-----------	------------------	----------	-----------	------------------	----------

Drive Shaft (4 W/D) (Cont.)

U-Joint (Cont.)

2004-2002 Silverado & Sierra w/ Ext. Cab & Std. Bed Exc. Quadrasteer & SS: [Type 13]

U-Joint (Fr. Shaft; Frt.) [⊙]	UJ534G
Brute Force Greaseable	UJ235
Brute Force Non Greaseable	UJ234
Clamp Kit (Fr. Shaft; Frt.)	UJ530-10
U-Joint (Fr. Shaft; Rr.) [⊙]	UJ534G
Brute Force Greaseable	UJ235
Brute Force Non Greaseable	UJ234
Clamp Kit (Fr. Shaft; Rr.)	UJ530-10
U-Joint (Rr. Shaft; Frt.) [⊙]	UJ354
Brute Force Greaseable	UJ270
Brute Force Non Greaseable	UJ254
(For Aluminum Drive Shaft)	UJ354C
U-Joint (Rr. Shaft; Rr.) [⊙]	UJ355
Brute Force Greaseable	UJ290
(For Aluminum Drive Shaft)	UJ355C
Clamp Kit (Rr. Shaft; Rr.)	UJ530-10

2004-2002 Silverado & Sierra w/ Ext. Cab, Std. Bed & Quadrasteer Exc. SS: [Type 13]

U-Joint (Fr. Shaft; Frt.) [⊙]	UJ534G
Brute Force Greaseable	UJ235
Brute Force Non Greaseable	UJ234
Clamp Kit (Fr. Shaft; Frt.)	UJ530-10
U-Joint (Fr. Shaft; Rr.) [⊙]	UJ534G
Brute Force Greaseable	UJ235
Brute Force Non Greaseable	UJ234
Clamp Kit (Fr. Shaft; Rr.)	UJ530-10
U-Joint (Rr. Shaft; Frt.) [⊙]	UJ331
Brute Force Greaseable	UJ232
Brute Force Non Greaseable	UJ231
(For Aluminum Drive Shaft)	UJ331C
Clamp Kit (Rr. Shaft; Frt.)	UJ492-10
U-Joint (Rr. Shaft; Rr.) [⊙]	UJ331
Brute Force Greaseable	UJ232
Brute Force Non Greaseable	UJ231
(For Aluminum Drive Shaft)	UJ331C
Clamp Kit (Rr. Shaft; Rr.)	UJ492-10

Drive Shaft (4 W/D) (Cont.)

U-Joint (Cont.)

2004-2002 Silverado & Sierra w/ Ext. Cab & Long Bed Exc. SS: [Type 14]

U-Joint (Fr. Shaft; Frt.) [⊙]	UJ534G
Brute Force Greaseable	UJ235
Brute Force Non Greaseable	UJ234
Clamp Kit (Fr. Shaft; Frt.)	UJ530-10
U-Joint (Fr. Shaft; Rr.) [⊙]	UJ534G
Brute Force Greaseable	UJ235
Brute Force Non Greaseable	UJ234
Clamp Kit (Fr. Shaft; Rr.)	UJ530-10
U-Joint (Rr. Shaft; Frt.) [⊙]	UJ354
Brute Force Greaseable	UJ270
Brute Force Non Greaseable	UJ254
(For Aluminum Drive Shaft)	UJ354C
U-Joint (Rr. Shaft; Ctr.) [⊙]	UJ354
Brute Force Greaseable	UJ270
Brute Force Non Greaseable	UJ254
(For Aluminum Drive Shaft)	UJ354C
U-Joint (Rr. Shaft; Rr.) [⊙]	UJ355
Brute Force Greaseable	UJ290
(For Aluminum Drive Shaft)	UJ355C
Clamp Kit (Rr. Shaft; Rr.)	UJ530-10

2003-2002 Silverado & Sierra w/ Crew Cab: [Type 14]

U-Joint (Fr. Shaft; Frt.) [⊙]	UJ534G
Brute Force Greaseable	UJ235
Brute Force Non Greaseable	UJ234
Clamp Kit (Fr. Shaft; Frt.)	UJ530-10
U-Joint (Fr. Shaft; Rr.) [⊙]	UJ534G
Brute Force Greaseable	UJ235
Brute Force Non Greaseable	UJ234
Clamp Kit (Fr. Shaft; Rr.)	UJ530-10
U-Joint (Rr. Shaft; Frt.) [⊙]	UJ331
Brute Force Greaseable	UJ232
Brute Force Non Greaseable	UJ231
(For Aluminum Drive Shaft)	UJ331C
Clamp Kit (Rr. Shaft; Frt.)	UJ492-10
U-Joint (Rr. Shaft; Ctr.) [⊙]	UJ331
Brute Force Greaseable	UJ232
Brute Force Non Greaseable	UJ231
(For Aluminum Drive Shaft)	UJ331C
Clamp Kit (Rr. Shaft; Ctr.)	UJ492-10
U-Joint (Rr. Shaft; Rr.) [⊙]	UJ331
Brute Force Greaseable	UJ232
Brute Force Non Greaseable	UJ231
(For Aluminum Drive Shaft)	UJ331C
Clamp Kit (Rr. Shaft; Rr.)	UJ492-10

(Continued)

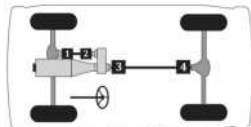

Type 13

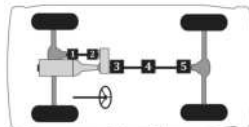

Type 14

130 ▲ For Use w/ 1.063" Bearing Cap Application. ⊙ For Use w/ 1.188" Bearing Cap Application. ◇ For Use w/ Inner Lock Ring Application on Half Shaft. □ For Use w/ Outer Lock Ring Application on Half Shaft.

Passenger cars, light & medium trucks

(Cont.) -- Chevrolet/GMC Truck 1/2 ton

MFG./YEAR	MODEL & LOCATION	PART NO.	MFG./YEAR	MODEL & LOCATION	PART NO.
Drive Shaft (4 W/D) (Cont.)			Drive Shaft (4 W/D) (Cont.)		
U-Joint (Cont.)			U-Joint (Cont.)		
2001	Silverado & Sierra w/ Crew Cab:		2001-1999	Silverado & Sierra w/ Ext. Cab & Std. Bed:	
	[Type 14]			[Type 13]	
	U-Joint (Fr. Shaft; Fr.) ^①	UJ534G		U-Joint (Fr. Shaft; Fr.) ^①	UJ534G
	Brute Force Greaseable	UJ235		Brute Force Greaseable	UJ235
	Brute Force Non Greaseable	UJ234		Brute Force Non Greaseable	UJ234
	Clamp Kit (Fr. Shaft; Fr.)	UJ530-10		Clamp Kit (Fr. Shaft; Fr.)	UJ530-10
	U-Joint (Fr. Shaft; Rr.) ^②	UJ534G		U-Joint (Fr. Shaft; Rr.) ^②	UJ534G
	Brute Force Greaseable	UJ235		Brute Force Greaseable	UJ235
	Brute Force Non Greaseable	UJ234		Brute Force Non Greaseable	UJ234
	Clamp Kit (Fr. Shaft; Rr.)	UJ530-10		Clamp Kit (Fr. Shaft; Rr.)	UJ530-10
	U-Joint (Rr. Shaft; Fr.) ^③	UJ331		U-Joint (Rr. Shaft; Fr.) ^③	UJ354
	Brute Force Greaseable	UJ232		Brute Force Greaseable	UJ270
	Brute Force Non Greaseable	UJ231		Brute Force Non Greaseable	UJ254
	(For Aluminum Drive Shaft)	UJ331C		(For Aluminum Drive Shaft)	UJ354C
	Clamp Kit (Rr. Shaft; Fr.)	UJ492-10		U-Joint (Rr. Shaft; Rr.) ^④	UJ355
	U-Joint (Rr. Shaft; Ctr.) ^④	UJ331		Brute Force Greaseable	UJ290
	Brute Force Greaseable	UJ232		(For Aluminum Drive Shaft)	UJ355C
	Brute Force Non Greaseable	UJ231		Clamp Kit (Rr. Shaft; Rr.)	UJ530-10
	(For Aluminum Drive Shaft)	UJ331C		2001-1999 Silverado & Sierra w/ Ext. Cab & Long Bed:	
	Clamp Kit (Rr. Shaft; Ctr.)	UJ492-10		[Type 14]	
	U-Joint (Rr. Shaft; Rr.) ^⑤	UJ331		U-Joint (Fr. Shaft; Fr.) ^①	UJ534G
	Brute Force Greaseable	UJ232		Brute Force Greaseable	UJ235
	Brute Force Non Greaseable	UJ231		Brute Force Non Greaseable	UJ234
	(For Aluminum Drive Shaft)	UJ331C		Clamp Kit (Fr. Shaft; Fr.)	UJ530-10
	Clamp Kit (Rr. Shaft; Rr.)	UJ492-10		U-Joint (Fr. Shaft; Rr.) ^②	UJ534G
	2001-1999 Silverado & Sierra w/ Reg. Cab:			Brute Force Greaseable	UJ235
	[Type 13]			Brute Force Non Greaseable	UJ234
	U-Joint (Fr. Shaft; Fr.) ^①	UJ534G		Clamp Kit (Fr. Shaft; Rr.)	UJ530-10
	Brute Force Greaseable	UJ235		U-Joint (Rr. Shaft; Fr.) ^③	UJ354
	Brute Force Non Greaseable	UJ234		Brute Force Greaseable	UJ270
	Clamp Kit (Fr. Shaft; Fr.)	UJ530-10		Brute Force Non Greaseable	UJ254
	U-Joint (Fr. Shaft; Rr.) ^②	UJ534G		(For Aluminum Drive Shaft)	UJ354C
	Brute Force Greaseable	UJ235		U-Joint (Rr. Shaft; Ctr.) ^④	UJ354
	Brute Force Non Greaseable	UJ234		Brute Force Greaseable	UJ270
	Clamp Kit (Fr. Shaft; Rr.)	UJ530-10		Brute Force Non Greaseable	UJ254
	U-Joint (Rr. Shaft; Fr.) ^③	UJ534G		(For Aluminum Drive Shaft)	UJ354C
	Brute Force Greaseable	UJ235		U-Joint (Rr. Shaft; Rr.) ^⑤	UJ355
	Brute Force Non Greaseable	UJ234		Brute Force Greaseable	UJ290
	Clamp Kit (Rr. Shaft; Fr.)	UJ530-10		(For Aluminum Drive Shaft)	UJ355C
	U-Joint (Rr. Shaft; Rr.) ^④	UJ534G		Clamp Kit (Rr. Shaft; Rr.)	UJ530-10
	Brute Force Greaseable	UJ235			
	Brute Force Non Greaseable	UJ234			
	Clamp Kit (Rr. Shaft; Rr.)	UJ530-10			

(Continued)

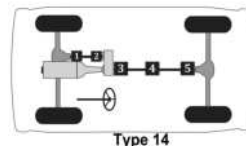
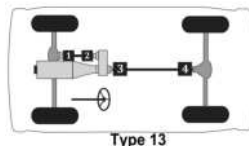

Passenger cars, light & medium trucks

Chevrolet/GMC Truck 1/2 ton -- (Cont.)

MFG./YEAR	MODEL & LOCATION	PART NO.	MFG./YEAR	MODEL & LOCATION	PART NO.
Drive Shaft (4 W/D) (Cont.)			Drive Shaft (4 W/D) (Cont.)		
U-Joint (Cont.)			U-Joint (Cont.)		
2000	Suburban & Yukon XL w/ Inner Lock Rings: [Type 13]		1999-1997	Suburban w/ Inner Lock Rings: [Type 13]	
	U-Joint (Fr. Shaft; Frt.) [⊙]	UJ534G		U-Joint (Fr. Shaft; Frt.) [⊙]	UJ534G
	Brute Force Greaseable	UJ235		Brute Force Greaseable	UJ235
	Brute Force Non Greaseable	UJ234		Brute Force Non Greaseable	UJ234
	Clamp Kit (Fr. Shaft; Frt.)	UJ530-10		Clamp Kit (Fr. Shaft; Frt.)	UJ530-10
	U-Joint (Fr. Shaft; Rr.) [⊙]	UJ534G		U-Joint (Fr. Shaft; Rr.) [⊙]	UJ534G
	Brute Force Greaseable	UJ235		Brute Force Greaseable	UJ235
	Brute Force Non Greaseable	UJ234		Brute Force Non Greaseable	UJ234
	Clamp Kit (Fr. Shaft; Rr.)	UJ530-10		Clamp Kit (Fr. Shaft; Rr.)	UJ530-10
	U-Joint (Rr. Shaft; Frt.) [⊙]	UJ534G		U-Joint (Rr. Shaft; Frt.) [⊙]	UJ534G
	Brute Force Greaseable	UJ235		Brute Force Greaseable	UJ235
	Brute Force Non Greaseable	UJ234		Brute Force Non Greaseable	UJ234
	Clamp Kit (Rr. Shaft; Frt.)	UJ530-10		Clamp Kit (Rr. Shaft; Frt.)	UJ530-10
	U-Joint (Rr. Shaft; Rr.) [⊙]	UJ534G		U-Joint (Rr. Shaft; Rr.) [⊙]	UJ534G
	Brute Force Greaseable	UJ235		Brute Force Greaseable	UJ235
	Brute Force Non Greaseable	UJ234		Brute Force Non Greaseable	UJ234
	Clamp Kit (Rr. Shaft; Rr.)	UJ530-10		Clamp Kit (Rr. Shaft; Rr.)	UJ530-10
2000	Suburban & Yukon XL w/ Outer Lock Rings: [Type 13]		1999-1997	Suburban w/ Outer Lock Rings: [Type 13]	
	U-Joint (Fr. Shaft; Frt.) [⊙]	UJ534G		U-Joint (Fr. Shaft; Frt.) [⊙]	UJ534G
	Brute Force Greaseable	UJ235		Brute Force Greaseable	UJ235
	Brute Force Non Greaseable	UJ234		Brute Force Non Greaseable	UJ234
	Clamp Kit (Fr. Shaft; Frt.)	UJ530-10		Clamp Kit (Fr. Shaft; Frt.)	UJ530-10
	U-Joint (Fr. Shaft; Rr.) [⊙]	UJ534G		U-Joint (Fr. Shaft; Rr.) [⊙]	UJ534G
	Brute Force Greaseable	UJ235		Brute Force Greaseable	UJ235
	Brute Force Non Greaseable	UJ234		Brute Force Non Greaseable	UJ234
	Clamp Kit (Fr. Shaft; Rr.)	UJ530-10		Clamp Kit (Fr. Shaft; Rr.)	UJ530-10
	U-Joint (Rr. Shaft; Frt.) [⊙]	UJ331		U-Joint (Rr. Shaft; Frt.) [⊙]	UJ331
	Brute Force Greaseable	UJ232		Brute Force Greaseable	UJ232
	Brute Force Non Greaseable	UJ231		Brute Force Non Greaseable	UJ231
	(For Aluminum Drive Shaft)	UJ331C		(For Aluminum Drive Shaft)	UJ331C
	Clamp Kit (Rr. Shaft; Frt.)	UJ492-10		Clamp Kit (Rr. Shaft; Frt.)	UJ492-10
	U-Joint (Rr. Shaft; Rr.) [⊙]	UJ331		U-Joint (Rr. Shaft; Rr.) [⊙]	UJ331
	Brute Force Greaseable	UJ232		Brute Force Greaseable	UJ232
	Brute Force Non Greaseable	UJ231		Brute Force Non Greaseable	UJ231
	(For Aluminum Drive Shaft)	UJ331C		(For Aluminum Drive Shaft)	UJ331C
	Clamp Kit (Rr. Shaft; Rr.)	UJ492-10		Clamp Kit (Rr. Shaft; Rr.)	UJ492-10

(Continued)

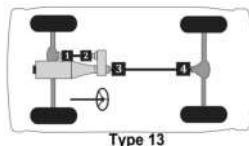

Passenger cars, light & medium trucks

(Cont.) -- Chevrolet/GMC Truck 1/2 ton

MFG./YEAR	MODEL & LOCATION	PART NO.	MFG./YEAR	MODEL & LOCATION	PART NO.
Drive Shaft (4 W/D) (Cont.)			Drive Shaft (4 W/D) (Cont.)		
U-Joint (Cont.)			U-Joint (Cont.)		
1999-1997 K1500 w/ Ext. Cab, Short Bed & Gas			1998-1997 K1500 w/ Ext. Cab, Short Bed & Diesel		
Eng. w/o HD Chassis: [Type 13]			Eng: [Type 13]		
U-Joint (Frt. Shaft; Frt.)		UJ534G	U-Joint (Frt. Shaft; Frt.)		UJ534G
<i>Brute Force Greaseable</i>		<i>UJ235</i>	<i>Brute Force Greaseable</i>		<i>UJ235</i>
<i>Brute Force Non Greaseable</i>		<i>UJ234</i>	<i>Brute Force Non Greaseable</i>		<i>UJ234</i>
Clamp Kit (Frt. Shaft; Frt.)		UJ530-10	Clamp Kit (Frt. Shaft; Frt.)		UJ530-10
U-Joint (Frt. Shaft; Rr.)		UJ534G	U-Joint (Frt. Shaft; Rr.)		UJ534G
<i>Brute Force Greaseable</i>		<i>UJ235</i>	<i>Brute Force Greaseable</i>		<i>UJ235</i>
<i>Brute Force Non Greaseable</i>		<i>UJ234</i>	<i>Brute Force Non Greaseable</i>		<i>UJ234</i>
Clamp Kit (Frt. Shaft; Rr.)		UJ530-10	Clamp Kit (Frt. Shaft; Rr.)		UJ530-10
U-Joint (Rr. Shaft; Frt.)		UJ354	U-Joint (Rr. Shaft; Frt.)		UJ331
<i>Brute Force Greaseable</i>		<i>UJ270</i>	<i>Brute Force Greaseable</i>		<i>UJ232</i>
<i>Brute Force Non Greaseable</i>		<i>UJ254</i>	<i>Brute Force Non Greaseable</i>		<i>UJ231</i>
(For Aluminum Drive Shaft)		UJ354C	(For Aluminum Drive Shaft)		UJ331C
U-Joint (Rr. Shaft; Rr.)		UJ355	Clamp Kit (Rr. Shaft; Frt.)		UJ492-10
<i>Brute Force Greaseable</i>		<i>UJ290</i>	U-Joint (Rr. Shaft; Rr.)		UJ331
(For Aluminum Drive Shaft)		UJ355C	<i>Brute Force Greaseable</i>		<i>UJ232</i>
Clamp Kit (Rr. Shaft; Rr.)		UJ530-10	<i>Brute Force Non Greaseable</i>		<i>UJ231</i>
			(For Aluminum Drive Shaft)		UJ331C
			Clamp Kit (Rr. Shaft; Rr.)		UJ492-10
1998-1997 K1500 w/ Reg. Cab: [Type 13]			1998-1997 K1500 w/ Ext. Cab, Short Bed & HD		
U-Joint (Frt. Shaft; Frt.)		UJ534G	Chassis: [Type 13]		
<i>Brute Force Greaseable</i>		<i>UJ235</i>	U-Joint (Frt. Shaft; Frt.)		UJ534G
<i>Brute Force Non Greaseable</i>		<i>UJ234</i>	<i>Brute Force Greaseable</i>		<i>UJ235</i>
Clamp Kit (Frt. Shaft; Frt.)		UJ530-10	<i>Brute Force Non Greaseable</i>		<i>UJ234</i>
U-Joint (Frt. Shaft; Rr.)		UJ534G	Clamp Kit (Frt. Shaft; Frt.)		UJ530-10
<i>Brute Force Greaseable</i>		<i>UJ235</i>	U-Joint (Frt. Shaft; Rr.)		UJ534G
<i>Brute Force Non Greaseable</i>		<i>UJ234</i>	<i>Brute Force Greaseable</i>		<i>UJ235</i>
Clamp Kit (Frt. Shaft; Rr.)		UJ530-10	<i>Brute Force Non Greaseable</i>		<i>UJ234</i>
U-Joint (Rr. Shaft; Frt.)		UJ534G	Clamp Kit (Frt. Shaft; Rr.)		UJ530-10
<i>Brute Force Greaseable</i>		<i>UJ235</i>	U-Joint (Rr. Shaft; Frt.)		UJ331
<i>Brute Force Non Greaseable</i>		<i>UJ234</i>	<i>Brute Force Greaseable</i>		<i>UJ232</i>
Clamp Kit (Rr. Shaft; Frt.)		UJ530-10	<i>Brute Force Non Greaseable</i>		<i>UJ231</i>
U-Joint (Rr. Shaft; Rr.)		UJ534G	(For Aluminum Drive Shaft)		UJ331C
<i>Brute Force Greaseable</i>		<i>UJ235</i>	Clamp Kit (Rr. Shaft; Frt.)		UJ492-10
<i>Brute Force Non Greaseable</i>		<i>UJ234</i>	U-Joint (Rr. Shaft; Rr.)		UJ331
Clamp Kit (Rr. Shaft; Rr.)		UJ530-10	<i>Brute Force Greaseable</i>		<i>UJ232</i>
			<i>Brute Force Non Greaseable</i>		<i>UJ231</i>
			(For Aluminum Drive Shaft)		UJ331C
			Clamp Kit (Rr. Shaft; Frt.)		UJ492-10
			U-Joint (Rr. Shaft; Rr.)		UJ331
			<i>Brute Force Greaseable</i>		<i>UJ232</i>
			<i>Brute Force Non Greaseable</i>		<i>UJ231</i>
			(For Aluminum Drive Shaft)		UJ331C
			Clamp Kit (Rr. Shaft; Rr.)		UJ492-10

(Continued)

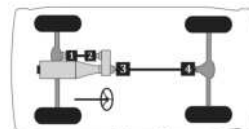

Passenger cars, light & medium trucks

Chevrolet/GMC Truck 1/2 ton -- (Cont.)

MFG./YEAR	MODEL & LOCATION	PART NO.	MFG./YEAR	MODEL & LOCATION	PART NO.
-----------	------------------	----------	-----------	------------------	----------

Drive Shaft (4 W/D) (Cont.)

U-Joint (Cont.)

1998-1997 K1500 w/ Ext. Cab, Long Bed & HD

Chassis: [Type 14]

U-Joint (Fr. Shaft; Frt.) [⊙]	UJ534G
Brute Force Greaseable	UJ235
Brute Force Non Greaseable	UJ234
Clamp Kit (Fr. Shaft; Frt.)	UJ530-10
U-Joint (Fr. Shaft; Rr.) [⊙]	UJ534G
Brute Force Greaseable	UJ235
Brute Force Non Greaseable	UJ234
Clamp Kit (Fr. Shaft; Rr.)	UJ530-10
U-Joint (Rr. Shaft; Frt.) [⊙]	UJ331
Brute Force Greaseable	UJ232
Brute Force Non Greaseable	UJ231
(For Aluminum Drive Shaft)	UJ331C
Clamp Kit (Rr. Shaft; Frt.)	UJ492-10
U-Joint (Rr. Shaft; Ctr.) [⊙]	UJ331
Brute Force Greaseable	UJ232
Brute Force Non Greaseable	UJ231
(For Aluminum Drive Shaft)	UJ331C
Clamp Kit (Rr. Shaft; Ctr.)	UJ492-10
U-Joint (Rr. Shaft; Rr.) [⊙]	UJ331
Brute Force Greaseable	UJ232
Brute Force Non Greaseable	UJ231
(For Aluminum Drive Shaft)	UJ331C
Clamp Kit (Rr. Shaft; Rr.)	UJ492-10

1998-1997 K1500 w/ Ext. Cab & Long Bed w/o HD

Chassis: [Type 14]

U-Joint (Fr. Shaft; Frt.) [⊙]	UJ534G
Brute Force Greaseable	UJ235
Brute Force Non Greaseable	UJ234
Clamp Kit (Fr. Shaft; Frt.)	UJ530-10
U-Joint (Fr. Shaft; Rr.) [⊙]	UJ534G
Brute Force Greaseable	UJ235
Brute Force Non Greaseable	UJ234
Clamp Kit (Fr. Shaft; Rr.)	UJ530-10
U-Joint (Rr. Shaft; Frt.) [⊙]	UJ354
Brute Force Greaseable	UJ270
Brute Force Non Greaseable	UJ254
(For Aluminum Drive Shaft)	UJ354C
U-Joint (Rr. Shaft; Ctr.) [⊙]	UJ354
Brute Force Greaseable	UJ270
Brute Force Non Greaseable	UJ254
(For Aluminum Drive Shaft)	UJ354C
U-Joint (Rr. Shaft; Rr.) [⊙]	UJ355
Brute Force Greaseable	UJ290
(For Aluminum Drive Shaft)	UJ355C
Clamp Kit (Rr. Shaft; Rr.)	UJ530-10

Drive Shaft (4 W/D) (Cont.)

U-Joint (Cont.)

1996 K1500 w/ Reg. Cab & Gas Eng.:

[Type 13]

U-Joint (Fr. Shaft; Frt.) [⊙]	UJ534G
Brute Force Greaseable	UJ235
Brute Force Non Greaseable	UJ234
Clamp Kit (Fr. Shaft; Frt.)	UJ530-10
U-Joint (Fr. Shaft; Rr.) [⊙]	UJ534G
Brute Force Greaseable	UJ235
Brute Force Non Greaseable	UJ234
Clamp Kit (Fr. Shaft; Rr.)	UJ530-10
U-Joint (Rr. Shaft; Frt.) [⊙]	UJ534G
Brute Force Greaseable	UJ235
Brute Force Non Greaseable	UJ234
Clamp Kit (Rr. Shaft; Frt.)	UJ530-10
U-Joint (Rr. Shaft; Rr.) [⊙]	UJ534G
Brute Force Greaseable	UJ235
Brute Force Non Greaseable	UJ234
Clamp Kit (Rr. Shaft; Rr.)	UJ530-10

1996 K1500 w/ Reg. Cab & Diesel Eng.:

[Type 13]

U-Joint (Fr. Shaft; Frt.) [⊙]	UJ355
Brute Force Greaseable	UJ290
(For Aluminum Drive Shaft)	UJ355C
U-Joint (Fr. Shaft; Rr.) [⊙]	UJ354
Brute Force Greaseable	UJ270
Brute Force Non Greaseable	UJ254
(For Aluminum Drive Shaft)	UJ354C
U-Joint (Rr. Shaft; Frt.) [⊙]	UJ534G
Brute Force Greaseable	UJ235
Brute Force Non Greaseable	UJ234
Clamp Kit (Rr. Shaft; Frt.)	UJ530-10
U-Joint (Rr. Shaft; Rr.) [⊙]	UJ534G
Brute Force Greaseable	UJ235
Brute Force Non Greaseable	UJ234
Clamp Kit (Rr. Shaft; Rr.)	UJ530-10

(Continued)

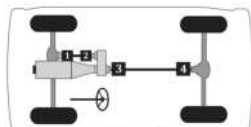

Type 13

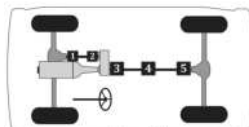

Type 14

SKF

Passenger cars, light & medium trucks

(Cont.) -- Chevrolet/GMC Truck 1/2 ton

MFG./YEAR	MODEL & LOCATION	PART NO.	MFG./YEAR	MODEL & LOCATION	PART NO.
Drive Shaft (4 W/D) (Cont.)			Drive Shaft (4 W/D) (Cont.)		
U-Joint (Cont.)			U-Joint (Cont.)		
1996	K1500 w/ Ext. Cab, Short Bed & Gas Eng. w/o HD Chassis: [Type 13]		1996	K1500 w/ Ext. Cab, Short Bed, Diesel Eng. & HD Chassis: [Type 13]	
	U-Joint (Frnt. Shaft; Frnt.) ^①	UJ534G		U-Joint (Frnt. Shaft; Frnt.) ^①	UJ355
	Brute Force Greaseable	UJ235		Brute Force Greaseable	UJ290
	Brute Force Non Greaseable	UJ234		(For Aluminum Drive Shaft)	UJ355C
	Clamp Kit (Frnt. Shaft; Frnt.)	UJ530-10		U-Joint (Frnt. Shaft; Rr.) ^②	UJ354
	U-Joint (Frnt. Shaft; Rr.) ^②	UJ534G		Brute Force Greaseable	UJ270
	Brute Force Greaseable	UJ235		Brute Force Non Greaseable	UJ254
	Brute Force Non Greaseable	UJ234		(For Aluminum Drive Shaft)	UJ354C
	Clamp Kit (Frnt. Shaft; Rr.)	UJ530-10		U-Joint (Rr. Shaft; Frnt.) ^③	UJ331
	U-Joint (Rr. Shaft; Frnt.) ^③	UJ354		Brute Force Greaseable	UJ232
	Brute Force Greaseable	UJ270		Brute Force Non Greaseable	UJ231
	Brute Force Non Greaseable	UJ254		(For Aluminum Drive Shaft)	UJ331C
	(For Aluminum Drive Shaft)	UJ354C		Clamp Kit (Rr. Shaft; Frnt.)	UJ492-10
	U-Joint (Rr. Shaft; Rr.) ^④	UJ355		U-Joint (Rr. Shaft; Rr.) ^④	UJ331
	Brute Force Greaseable	UJ290		Brute Force Greaseable	UJ232
	(For Aluminum Drive Shaft)	UJ355C		Brute Force Non Greaseable	UJ231
	Clamp Kit (Rr. Shaft; Rr.)	UJ530-10		(For Aluminum Drive Shaft)	UJ331C
1996	K1500 w/ Ext. Cab, Short Bed, Gas Eng. & HD Chassis: [Type 13]		1996	K1500 w/ Ext. Cab, Short Bed, Diesel Eng. w/o HD Chassis: [Type 13]	
	U-Joint (Frnt. Shaft; Frnt.) ^①	UJ534G		U-Joint (Frnt. Shaft; Frnt.) ^①	UJ355
	Brute Force Greaseable	UJ235		Brute Force Greaseable	UJ290
	Brute Force Non Greaseable	UJ234		(For Aluminum Drive Shaft)	UJ355C
	Clamp Kit (Frnt. Shaft; Frnt.)	UJ530-10		U-Joint (Frnt. Shaft; Rr.) ^②	UJ354
	U-Joint (Frnt. Shaft; Rr.) ^②	UJ534G		Brute Force Greaseable	UJ270
	Brute Force Greaseable	UJ235		Brute Force Non Greaseable	UJ254
	Brute Force Non Greaseable	UJ234		(For Aluminum Drive Shaft)	UJ354C
	Clamp Kit (Frnt. Shaft; Rr.)	UJ530-10		U-Joint (Rr. Shaft; Frnt.) ^③	UJ354
	U-Joint (Rr. Shaft; Frnt.) ^③	UJ331		Brute Force Greaseable	UJ270
	Brute Force Greaseable	UJ232		Brute Force Non Greaseable	UJ254
	Brute Force Non Greaseable	UJ231		(For Aluminum Drive Shaft)	UJ354C
	(For Aluminum Drive Shaft)	UJ331C		U-Joint (Rr. Shaft; Rr.) ^④	UJ355
	Clamp Kit (Rr. Shaft; Frnt.)	UJ492-10		Brute Force Greaseable	UJ290
	U-Joint (Rr. Shaft; Rr.) ^④	UJ331		(For Aluminum Drive Shaft)	UJ355C
	Brute Force Greaseable	UJ232		Clamp Kit (Rr. Shaft; Rr.)	UJ530-10
	Brute Force Non Greaseable	UJ231			
	(For Aluminum Drive Shaft)	UJ331C			
	Clamp Kit (Rr. Shaft; Rr.)	UJ492-10			

(Continued)

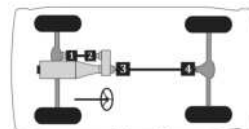

Type 13

Passenger cars, light & medium trucks

Chevrolet/GMC Truck 1/2 ton -- (Cont.)

MFG./YEAR	MODEL & LOCATION	PART NO.	MFG./YEAR	MODEL & LOCATION	PART NO.
-----------	------------------	----------	-----------	------------------	----------

Drive Shaft (4 W/D) (Cont.)

U-Joint (Cont.)

1996	K1500 w/ Ext. Cab, Long Bed & Diesel	
	Eng.: [Type 14]	
U-Joint (Fr. Shaft; Frt.)		UJ355
<i>Brute Force Greaseable</i>		<i>UJ290</i>
(For Aluminum Drive Shaft)		UJ355C
U-Joint (Fr. Shaft; Rr.)		UJ354
<i>Brute Force Greaseable</i>		<i>UJ270</i>
<i>Brute Force Non Greaseable</i>		<i>UJ254</i>
(For Aluminum Drive Shaft)		UJ354C
U-Joint (Rr. Shaft; Frt.)		UJ331
<i>Brute Force Greaseable</i>		<i>UJ232</i>
<i>Brute Force Non Greaseable</i>		<i>UJ231</i>
(For Aluminum Drive Shaft)		UJ331C
Clamp Kit (Rr. Shaft; Frt.)		UJ492-10
U-Joint (Rr. Shaft; Ctr.)		UJ331
<i>Brute Force Greaseable</i>		<i>UJ232</i>
<i>Brute Force Non Greaseable</i>		<i>UJ231</i>
(For Aluminum Drive Shaft)		UJ331C
Clamp Kit (Rr. Shaft; Ctr.)		UJ492-10
U-Joint (Rr. Shaft; Rr.)		UJ331
<i>Brute Force Greaseable</i>		<i>UJ232</i>
<i>Brute Force Non Greaseable</i>		<i>UJ231</i>
(For Aluminum Drive Shaft)		UJ331C
Clamp Kit (Rr. Shaft; Rr.)		UJ492-10
1996	K1500 w/ Ext. Cab, Long Bed & Gas	
	Eng.: [Type 14]	
U-Joint (Fr. Shaft; Frt.)		UJ534G
<i>Brute Force Greaseable</i>		<i>UJ235</i>
<i>Brute Force Non Greaseable</i>		<i>UJ234</i>
Clamp Kit (Fr. Shaft; Frt.)		UJ530-10
U-Joint (Fr. Shaft; Rr.)		UJ534G
<i>Brute Force Greaseable</i>		<i>UJ235</i>
<i>Brute Force Non Greaseable</i>		<i>UJ234</i>
Clamp Kit (Fr. Shaft; Rr.)		UJ530-10
U-Joint (Rr. Shaft; Frt.)		UJ331
<i>Brute Force Greaseable</i>		<i>UJ232</i>
<i>Brute Force Non Greaseable</i>		<i>UJ231</i>
(For Aluminum Drive Shaft)		UJ331C
Clamp Kit (Rr. Shaft; Frt.)		UJ492-10
U-Joint (Rr. Shaft; Ctr.)		UJ331
<i>Brute Force Greaseable</i>		<i>UJ232</i>
<i>Brute Force Non Greaseable</i>		<i>UJ231</i>
(For Aluminum Drive Shaft)		UJ331C
Clamp Kit (Rr. Shaft; Ctr.)		UJ492-10
U-Joint (Rr. Shaft; Rr.)		UJ331
<i>Brute Force Greaseable</i>		<i>UJ232</i>
<i>Brute Force Non Greaseable</i>		<i>UJ231</i>
(For Aluminum Drive Shaft)		UJ331C
Clamp Kit (Rr. Shaft; Rr.)		UJ492-10

Drive Shaft (4 W/D) (Cont.)

U-Joint (Cont.)

1996-1995 Suburban w/ Diesel Eng. & Auto.	
Trans.: [Type 13]	
U-Joint (Fr. Shaft; Frt.)	UJ355
<i>Brute Force Greaseable</i>	<i>UJ290</i>
(For Aluminum Drive Shaft)	UJ355C
U-Joint (Fr. Shaft; Rr.)	UJ354
<i>Brute Force Greaseable</i>	<i>UJ270</i>
<i>Brute Force Non Greaseable</i>	<i>UJ254</i>
(For Aluminum Drive Shaft)	UJ354C
U-Joint (Rr. Shaft; Frt.)	UJ534G
<i>Brute Force Greaseable</i>	<i>UJ235</i>
<i>Brute Force Non Greaseable</i>	<i>UJ234</i>
Clamp Kit (Rr. Shaft; Frt.)	UJ530-10
U-Joint (Rr. Shaft; Rr.)	UJ534G
<i>Brute Force Greaseable</i>	<i>UJ235</i>
<i>Brute Force Non Greaseable</i>	<i>UJ234</i>
Clamp Kit (Rr. Shaft; Rr.)	UJ530-10
1996-1995 Suburban w/ Diesel Eng. & Man.	
Trans.: [Type 13]	
U-Joint (Fr. Shaft; Frt.)	UJ355
<i>Brute Force Greaseable</i>	<i>UJ290</i>
(For Aluminum Drive Shaft)	UJ355C
U-Joint (Fr. Shaft; Rr.)	UJ354
<i>Brute Force Greaseable</i>	<i>UJ270</i>
<i>Brute Force Non Greaseable</i>	<i>UJ254</i>
(For Aluminum Drive Shaft)	UJ354C
U-Joint (Rr. Shaft; Frt.)	UJ331
<i>Brute Force Greaseable</i>	<i>UJ232</i>
<i>Brute Force Non Greaseable</i>	<i>UJ231</i>
(For Aluminum Drive Shaft)	UJ331C
Clamp Kit (Rr. Shaft; Frt.)	UJ492-10
U-Joint (Rr. Shaft; Rr.)	UJ331
<i>Brute Force Greaseable</i>	<i>UJ232</i>
<i>Brute Force Non Greaseable</i>	<i>UJ231</i>
(For Aluminum Drive Shaft)	UJ331C
Clamp Kit (Rr. Shaft; Rr.)	UJ492-10

(Continued)

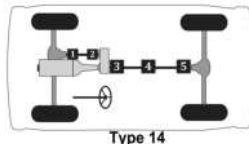
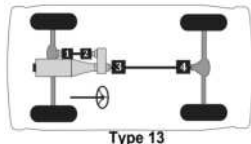

Passenger cars, light & medium trucks

(Cont.) -- Chevrolet/GMC Truck 1/2 ton

MFG./YEAR	MODEL & LOCATION	PART NO.	MFG./YEAR	MODEL & LOCATION	PART NO.
Drive Shaft (4 W/D) (Cont.)			Drive Shaft (4 W/D) (Cont.)		
U-Joint (Cont.)			U-Joint (Cont.)		
1996-1994 Suburban w/ Gas Eng. & Auto. Trans.:			1995 K1500 w/ Reg. Cab, Gas Eng. & MW3		
[Type 13]			Man. Trans.: [Type 13]		
U-Joint (Frt. Shaft; Frt.) ①		UJ534G	U-Joint (Frt. Shaft; Frt.) ①		UJ534G
<i>Brute Force Greaseable</i>		UJ235	<i>Brute Force Greaseable</i>		UJ235
<i>Brute Force Non Greaseable</i>		UJ234	<i>Brute Force Non Greaseable</i>		UJ234
Clamp Kit (Frt. Shaft; Frt.)		UJ530-10	Clamp Kit (Frt. Shaft; Frt.)		UJ530-10
U-Joint (Frt. Shaft; Rr.) ②		UJ534G	U-Joint (Frt. Shaft; Rr.) ②		UJ534G
<i>Brute Force Greaseable</i>		UJ235	<i>Brute Force Greaseable</i>		UJ235
<i>Brute Force Non Greaseable</i>		UJ234	<i>Brute Force Non Greaseable</i>		UJ234
Clamp Kit (Frt. Shaft; Rr.)		UJ530-10	Clamp Kit (Frt. Shaft; Rr.)		UJ530-10
U-Joint (Rr. Shaft; Frt.) ③		UJ534G	U-Joint (Rr. Shaft; Frt.) ③		UJ331
<i>Brute Force Greaseable</i>		UJ235	<i>Brute Force Greaseable</i>		UJ232
<i>Brute Force Non Greaseable</i>		UJ234	<i>Brute Force Non Greaseable</i>		UJ231
Clamp Kit (Rr. Shaft; Frt.)		UJ530-10	(For Aluminum Drive Shaft)		UJ331C
U-Joint (Rr. Shaft; Rr.) ④		UJ534G	Clamp Kit (Rr. Shaft; Frt.)		UJ492-10
<i>Brute Force Greaseable</i>		UJ235	U-Joint (Rr. Shaft; Rr.) ④		UJ331
<i>Brute Force Non Greaseable</i>		UJ234	<i>Brute Force Greaseable</i>		UJ232
Clamp Kit (Rr. Shaft; Rr.)		UJ530-10	<i>Brute Force Non Greaseable</i>		UJ231
1996-1994 Suburban w/ Gas Eng. & Man. Trans.:			(For Aluminum Drive Shaft)		UJ331C
[Type 13]			Clamp Kit (Rr. Shaft; Rr.)		UJ492-10
U-Joint (Frt. Shaft; Frt.) ①		UJ534G	1995 K1500 w/ Reg. Cab & Gas Eng. Exc.		
<i>Brute Force Greaseable</i>		UJ235	MW3 Man. Trans.: [Type 13]		
<i>Brute Force Non Greaseable</i>		UJ234	U-Joint (Frt. Shaft; Frt.) ①		UJ534G
Clamp Kit (Frt. Shaft; Frt.)		UJ530-10	<i>Brute Force Greaseable</i>		UJ235
U-Joint (Frt. Shaft; Rr.) ②		UJ534G	<i>Brute Force Non Greaseable</i>		UJ234
<i>Brute Force Greaseable</i>		UJ235	Clamp Kit (Frt. Shaft; Frt.)		UJ530-10
<i>Brute Force Non Greaseable</i>		UJ234	U-Joint (Frt. Shaft; Rr.) ②		UJ534G
Clamp Kit (Frt. Shaft; Rr.)		UJ530-10	<i>Brute Force Greaseable</i>		UJ235
U-Joint (Rr. Shaft; Frt.) ③		UJ331	<i>Brute Force Non Greaseable</i>		UJ234
<i>Brute Force Greaseable</i>		UJ232	Clamp Kit (Frt. Shaft; Rr.)		UJ530-10
<i>Brute Force Non Greaseable</i>		UJ231	U-Joint (Rr. Shaft; Frt.) ③		UJ534G
(For Aluminum Drive Shaft)		UJ331C	<i>Brute Force Greaseable</i>		UJ235
Clamp Kit (Rr. Shaft; Frt.)		UJ492-10	<i>Brute Force Non Greaseable</i>		UJ234
U-Joint (Rr. Shaft; Rr.) ④		UJ331	Clamp Kit (Rr. Shaft; Frt.)		UJ530-10
<i>Brute Force Greaseable</i>		UJ232	U-Joint (Rr. Shaft; Rr.) ④		UJ534G
<i>Brute Force Non Greaseable</i>		UJ231	<i>Brute Force Greaseable</i>		UJ235
(For Aluminum Drive Shaft)		UJ331C	<i>Brute Force Non Greaseable</i>		UJ234
Clamp Kit (Rr. Shaft; Rr.)		UJ492-10	Clamp Kit (Rr. Shaft; Rr.)		UJ530-10

(Continued)

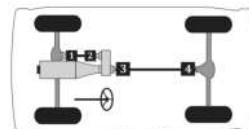

Type 13

Passenger cars, light & medium trucks

Chevrolet/GMC Truck 1/2 ton -- (Cont.)

MFG./YEAR	MODEL & LOCATION	PART NO.	MFG./YEAR	MODEL & LOCATION	PART NO.
Drive Shaft (4 W/D) (Cont.)			Drive Shaft (4 W/D) (Cont.)		
U-Joint (Cont.)			U-Joint (Cont.)		
1995	K1500 w/ Reg. Cab, Diesel Eng. & MW3 Man. Trans.: [Type 13]		1995	K1500 w/ Ext. Cab, Short Bed, Gas Eng. & HD Chassis: [Type 13]	
	U-Joint (Fr. Shaft; Frt.) ⊙	UJ355		U-Joint (Fr. Shaft; Frt.) ⊙	UJ534G
	Brute Force Greaseable	UJ290		Brute Force Greaseable	UJ235
	(For Aluminum Drive Shaft)	UJ355C		Brute Force Non Greaseable	UJ234
	U-Joint (Fr. Shaft; Rr.) ⊙	UJ354		Clamp Kit (Fr. Shaft; Frt.)	UJ530-10
	Brute Force Greaseable	UJ270		U-Joint (Fr. Shaft; Rr.) ⊙	UJ534G
	Brute Force Non Greaseable	UJ254		Brute Force Greaseable	UJ235
	(For Aluminum Drive Shaft)	UJ354C		Brute Force Non Greaseable	UJ234
	U-Joint (Rr. Shaft; Frt.) ⊙	UJ331		Clamp Kit (Fr. Shaft; Rr.)	UJ530-10
	Brute Force Greaseable	UJ232		U-Joint (Rr. Shaft; Frt.) ⊙	UJ331
	Brute Force Non Greaseable	UJ231		Brute Force Greaseable	UJ232
	(For Aluminum Drive Shaft)	UJ331C		Brute Force Non Greaseable	UJ231
	Clamp Kit (Rr. Shaft; Frt.)	UJ492-10		(For Aluminum Drive Shaft)	UJ331C
	U-Joint (Rr. Shaft; Rr.) ⊙	UJ331		Clamp Kit (Rr. Shaft; Frt.)	UJ492-10
	Brute Force Greaseable	UJ232		U-Joint (Rr. Shaft; Rr.) ⊙	UJ331
	Brute Force Non Greaseable	UJ231		Brute Force Greaseable	UJ232
	(For Aluminum Drive Shaft)	UJ331C		Brute Force Non Greaseable	UJ231
	Clamp Kit (Rr. Shaft; Rr.)	UJ492-10		(For Aluminum Drive Shaft)	UJ331C
1995	K1500 w/ Reg. Cab & Diesel Eng. Exc. MW3 Man. Trans.: [Type 13]		1995	K1500 w/ Ext. Cab, Short Bed, Gas Eng. & MW3 Man. Trans.: [Type 13]	
	U-Joint (Fr. Shaft; Frt.) ⊙	UJ355		U-Joint (Fr. Shaft; Frt.) ⊙	UJ534G
	Brute Force Greaseable	UJ290		Brute Force Greaseable	UJ235
	(For Aluminum Drive Shaft)	UJ355C		Brute Force Non Greaseable	UJ234
	U-Joint (Fr. Shaft; Rr.) ⊙	UJ354		Clamp Kit (Fr. Shaft; Frt.)	UJ530-10
	Brute Force Greaseable	UJ270		U-Joint (Fr. Shaft; Rr.) ⊙	UJ534G
	Brute Force Non Greaseable	UJ254		Brute Force Greaseable	UJ235
	(For Aluminum Drive Shaft)	UJ354C		Brute Force Non Greaseable	UJ234
	U-Joint (Rr. Shaft; Frt.) ⊙	UJ534G		Clamp Kit (Fr. Shaft; Rr.)	UJ530-10
	Brute Force Greaseable	UJ235		U-Joint (Rr. Shaft; Frt.) ⊙	UJ331
	Brute Force Non Greaseable	UJ234		Brute Force Greaseable	UJ232
	Clamp Kit (Rr. Shaft; Frt.)	UJ530-10		Brute Force Non Greaseable	UJ231
	U-Joint (Rr. Shaft; Rr.) ⊙	UJ534G		(For Aluminum Drive Shaft)	UJ331C
	Brute Force Greaseable	UJ235		Clamp Kit (Rr. Shaft; Frt.)	UJ492-10
	Brute Force Non Greaseable	UJ234		U-Joint (Rr. Shaft; Rr.) ⊙	UJ331
	Clamp Kit (Rr. Shaft; Rr.)	UJ530-10		Brute Force Greaseable	UJ232
				Brute Force Non Greaseable	UJ231
				(For Aluminum Drive Shaft)	UJ331C
				Clamp Kit (Rr. Shaft; Rr.)	UJ492-10

(Continued)

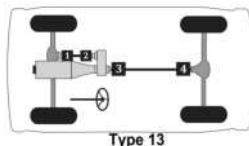

Passenger cars, light & medium trucks

(Cont.) -- Chevrolet/GMC Truck 1/2 ton

MFG./YEAR	MODEL & LOCATION	PART NO.	MFG./YEAR	MODEL & LOCATION	PART NO.
Drive Shaft (4 W/D) (Cont.)			Drive Shaft (4 W/D) (Cont.)		
U-Joint (Cont.)			U-Joint (Cont.)		
1995	K1500 w/ Ext. Cab, Short Bed & Gas Eng. Exc. MW3 Man. Trans.: [Type 13]		1995	K1500 w/ Ext. Cab, Short Bed, Diesel Eng. & HD Chassis: [Type 13]	
	U-Joint (Frnt. Shaft; Frnt.) ①	UJ534G		U-Joint (Frnt. Shaft; Frnt.) ①	UJ355
	<i>Brute Force Greaseable</i>	UJ235		<i>Brute Force Greaseable</i>	UJ290
	<i>Brute Force Non Greaseable</i>	UJ234		(For Aluminum Drive Shaft)	UJ355C
	Clamp Kit (Frnt. Shaft; Frnt.)	UJ530-10		U-Joint (Frnt. Shaft; Rr.) ②	UJ354
	U-Joint (Frnt. Shaft; Rr.) ②	UJ534G		<i>Brute Force Greaseable</i>	UJ270
	<i>Brute Force Greaseable</i>	UJ235		<i>Brute Force Non Greaseable</i>	UJ254
	<i>Brute Force Non Greaseable</i>	UJ234		(For Aluminum Drive Shaft)	UJ354C
	Clamp Kit (Frnt. Shaft; Rr.)	UJ530-10		U-Joint (Rr. Shaft; Frnt.) ③	UJ331
	U-Joint (Rr. Shaft; Frnt.) ③	UJ354		<i>Brute Force Greaseable</i>	UJ232
	<i>Brute Force Greaseable</i>	UJ270		<i>Brute Force Non Greaseable</i>	UJ231
	<i>Brute Force Non Greaseable</i>	UJ254		(For Aluminum Drive Shaft)	UJ331C
	(For Aluminum Drive Shaft)	UJ354C		Clamp Kit (Rr. Shaft; Frnt.)	UJ492-10
	U-Joint (Rr. Shaft; Rr.) ④	UJ355		U-Joint (Rr. Shaft; Rr.) ④	UJ331
	<i>Brute Force Greaseable</i>	UJ290		<i>Brute Force Greaseable</i>	UJ232
	<i>Brute Force Non Greaseable</i>	UJ254		<i>Brute Force Non Greaseable</i>	UJ231
	(For Aluminum Drive Shaft)	UJ355C		(For Aluminum Drive Shaft)	UJ331C
	Clamp Kit (Rr. Shaft; Rr.)	UJ530-10		Clamp Kit (Rr. Shaft; Rr.)	UJ492-10
1995	K1500 w/ Ext. Cab, Short Bed & Gas Eng. w/o HD Chassis: [Type 13]		1995	K1500 w/ Ext. Cab, Short Bed, Diesel Eng. & MW3 Man. Trans.: [Type 13]	
	U-Joint (Frnt. Shaft; Frnt.) ①	UJ534G		U-Joint (Frnt. Shaft; Frnt.) ①	UJ355
	<i>Brute Force Greaseable</i>	UJ235		<i>Brute Force Greaseable</i>	UJ290
	<i>Brute Force Non Greaseable</i>	UJ234		(For Aluminum Drive Shaft)	UJ355C
	Clamp Kit (Frnt. Shaft; Frnt.)	UJ530-10		U-Joint (Frnt. Shaft; Rr.) ②	UJ354
	U-Joint (Frnt. Shaft; Rr.) ②	UJ534G		<i>Brute Force Greaseable</i>	UJ270
	<i>Brute Force Greaseable</i>	UJ235		<i>Brute Force Non Greaseable</i>	UJ254
	<i>Brute Force Non Greaseable</i>	UJ234		(For Aluminum Drive Shaft)	UJ354C
	Clamp Kit (Frnt. Shaft; Rr.)	UJ530-10		U-Joint (Rr. Shaft; Frnt.) ③	UJ331
	U-Joint (Rr. Shaft; Frnt.) ③	UJ354		<i>Brute Force Greaseable</i>	UJ232
	<i>Brute Force Greaseable</i>	UJ270		<i>Brute Force Non Greaseable</i>	UJ231
	<i>Brute Force Non Greaseable</i>	UJ254		(For Aluminum Drive Shaft)	UJ331C
	(For Aluminum Drive Shaft)	UJ354C		Clamp Kit (Rr. Shaft; Frnt.)	UJ492-10
	U-Joint (Rr. Shaft; Rr.) ④	UJ355		U-Joint (Rr. Shaft; Rr.) ④	UJ331
	<i>Brute Force Greaseable</i>	UJ290		<i>Brute Force Greaseable</i>	UJ232
	<i>Brute Force Non Greaseable</i>	UJ254		<i>Brute Force Non Greaseable</i>	UJ231
	(For Aluminum Drive Shaft)	UJ355C		(For Aluminum Drive Shaft)	UJ331C
	Clamp Kit (Rr. Shaft; Rr.)	UJ530-10		Clamp Kit (Rr. Shaft; Rr.)	UJ492-10

(Continued)

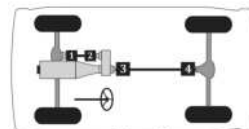

Type 13

Passenger cars, light & medium trucks

Chevrolet/GMC Truck 1/2 ton -- (Cont.)

MFG./YEAR	MODEL & LOCATION	PART NO.	MFG./YEAR	MODEL & LOCATION	PART NO.
-----------	------------------	----------	-----------	------------------	----------

Drive Shaft (4 W/D) (Cont.)

U-Joint (Cont.)

1995	K1500 w/ Ext. Cab, Short Bed & Diesel Eng. Exc. MW3 Man. Trans.: [Type 13]	
	U-Joint (Fr. Shaft; Frt.) ⊙	UJ355
	<i>Brute Force Greaseable</i>	UJ290
	(For Aluminum Drive Shaft)	UJ355C
	U-Joint (Fr. Shaft; Rr.) ⊙	UJ354
	<i>Brute Force Greaseable</i>	UJ270
	<i>Brute Force Non Greaseable</i>	UJ254
	(For Aluminum Drive Shaft)	UJ354C
	U-Joint (Rr. Shaft; Frt.) ⊙	UJ354
	<i>Brute Force Greaseable</i>	UJ270
	<i>Brute Force Non Greaseable</i>	UJ254
	(For Aluminum Drive Shaft)	UJ354C
	U-Joint (Rr. Shaft; Rr.) ⊙	UJ354
	<i>Brute Force Greaseable</i>	UJ270
	<i>Brute Force Non Greaseable</i>	UJ254
	(For Aluminum Drive Shaft)	UJ354C
1995	K1500 w/ Ext. Cab, Short Bed & Diesel Eng. w/o HD Chassis: [Type 13]	
	U-Joint (Fr. Shaft; Frt.) ⊙	UJ355
	<i>Brute Force Greaseable</i>	UJ290
	(For Aluminum Drive Shaft)	UJ355C
	U-Joint (Fr. Shaft; Rr.) ⊙	UJ354
	<i>Brute Force Greaseable</i>	UJ270
	<i>Brute Force Non Greaseable</i>	UJ254
	(For Aluminum Drive Shaft)	UJ354C
	U-Joint (Rr. Shaft; Frt.) ⊙	UJ354
	<i>Brute Force Greaseable</i>	UJ270
	<i>Brute Force Non Greaseable</i>	UJ254
	(For Aluminum Drive Shaft)	UJ354C
	U-Joint (Rr. Shaft; Rr.) ⊙	UJ355
	<i>Brute Force Greaseable</i>	UJ290
	(For Aluminum Drive Shaft)	UJ355C
	Clamp Kit (Rr. Shaft; Rr.)	UJ530-10

Drive Shaft (4 W/D) (Cont.)

U-Joint (Cont.)

1995	K1500 w/ Ext. Cab, Long Bed & Gas Eng. w/o HD Chassis: [Type 14]	
	U-Joint (Fr. Shaft; Frt.) ⊙	UJ534G
	<i>Brute Force Greaseable</i>	UJ235
	Brute Force Non Greaseable	UJ234
	Clamp Kit (Fr. Shaft; Frt.)	UJ530-10
	U-Joint (Fr. Shaft; Rr.) ⊙	UJ534G
	<i>Brute Force Greaseable</i>	UJ235
	<i>Brute Force Non Greaseable</i>	UJ234
	Clamp Kit (Fr. Shaft; Rr.)	UJ530-10
	U-Joint (Rr. Shaft; Frt.) ⊙	UJ354
	<i>Brute Force Greaseable</i>	UJ270
	<i>Brute Force Non Greaseable</i>	UJ254
	(For Aluminum Drive Shaft)	UJ354C
	U-Joint (Rr. Shaft; Ctr.) ⊙	UJ354
	<i>Brute Force Greaseable</i>	UJ270
	<i>Brute Force Non Greaseable</i>	UJ254
	(For Aluminum Drive Shaft)	UJ354C
	U-Joint (Rr. Shaft; Rr.) ⊙	UJ355
	<i>Brute Force Greaseable</i>	UJ290
	(For Aluminum Drive Shaft)	UJ355C
	Clamp Kit (Rr. Shaft; Rr.)	UJ530-10
1995	K1500 w/ Ext. Cab, Long Bed & Gas Eng. Exc. MW3 Man. Trans.: [Type 14]	
	U-Joint (Fr. Shaft; Frt.) ⊙	UJ534G
	<i>Brute Force Greaseable</i>	UJ235
	<i>Brute Force Non Greaseable</i>	UJ234
	Clamp Kit (Fr. Shaft; Frt.)	UJ530-10
	U-Joint (Fr. Shaft; Rr.) ⊙	UJ534G
	<i>Brute Force Greaseable</i>	UJ235
	<i>Brute Force Non Greaseable</i>	UJ234
	Clamp Kit (Fr. Shaft; Rr.)	UJ530-10
	U-Joint (Rr. Shaft; Frt.) ⊙	UJ354
	<i>Brute Force Greaseable</i>	UJ270
	<i>Brute Force Non Greaseable</i>	UJ254
	(For Aluminum Drive Shaft)	UJ354C
	U-Joint (Rr. Shaft; Ctr.) ⊙	UJ354
	<i>Brute Force Greaseable</i>	UJ270
	<i>Brute Force Non Greaseable</i>	UJ254
	(For Aluminum Drive Shaft)	UJ354C
	U-Joint (Rr. Shaft; Rr.) ⊙	UJ355
	<i>Brute Force Greaseable</i>	UJ290
	(For Aluminum Drive Shaft)	UJ355C
	Clamp Kit (Rr. Shaft; Rr.)	UJ530-10

(Continued)

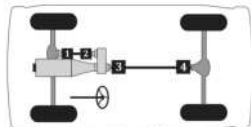

Type 13

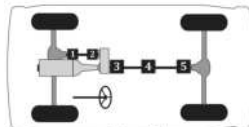

Type 14

Passenger cars, light & medium trucks

(Cont.) -- Chevrolet/GMC Truck 1/2 ton

MFG./YEAR	MODEL & LOCATION	PART NO.	MFG./YEAR	MODEL & LOCATION	PART NO.
Drive Shaft (4 W/D) (Cont.)			Drive Shaft (4 W/D) (Cont.)		
U-Joint (Cont.)			U-Joint (Cont.)		
1995	K1500 w/ Ext. Cab, Long Bed, Gas Eng. & HD Chassis: [Type 14]		1995	K1500 w/ Ext. Cab, Long Bed & Diesel Eng. w/o HD Chassis: [Type 14]	
	U-Joint (Frnt. Shaft; Frt.) ①	UJ534G		U-Joint (Frnt. Shaft; Frt.) ①	UJ355
	Brute Force Greaseable	UJ235		Brute Force Greaseable	UJ290
	Brute Force Non Greaseable	UJ234		(For Aluminum Drive Shaft)	UJ355C
	Clamp Kit (Frnt. Shaft; Frt.)	UJ530-10		U-Joint (Frnt. Shaft; Rr.) ②	UJ354
	U-Joint (Frnt. Shaft; Rr.) ②	UJ534G		Brute Force Greaseable	UJ270
	Brute Force Greaseable	UJ235		Brute Force Non Greaseable	UJ254
	Brute Force Non Greaseable	UJ234		(For Aluminum Drive Shaft)	UJ354C
	Clamp Kit (Frnt. Shaft; Rr.)	UJ530-10		U-Joint (Rr. Shaft; Frt.) ③	UJ354
	U-Joint (Rr. Shaft; Frt.) ③	UJ331		Brute Force Greaseable	UJ270
	Brute Force Greaseable	UJ232		Brute Force Non Greaseable	UJ254
	Brute Force Non Greaseable	UJ231		(For Aluminum Drive Shaft)	UJ354C
	(For Aluminum Drive Shaft)	UJ331C		U-Joint (Rr. Shaft; Ctr.) ④	UJ354
	Clamp Kit (Rr. Shaft; Frt.)	UJ492-10		Brute Force Greaseable	UJ270
	U-Joint (Rr. Shaft; Ctr.) ④	UJ331		Brute Force Non Greaseable	UJ254
	Brute Force Greaseable	UJ232		(For Aluminum Drive Shaft)	UJ354C
	Brute Force Non Greaseable	UJ231		U-Joint (Rr. Shaft; Rr.) ⑤	UJ355
	(For Aluminum Drive Shaft)	UJ331C		Brute Force Greaseable	UJ290
	Clamp Kit (Rr. Shaft; Ctr.)	UJ492-10		(For Aluminum Drive Shaft)	UJ355C
	U-Joint (Rr. Shaft; Rr.) ⑤	UJ331		Clamp Kit (Rr. Shaft; Rr.)	UJ530-10
	Brute Force Greaseable	UJ232			
	Brute Force Non Greaseable	UJ231			
	(For Aluminum Drive Shaft)	UJ331C			
	Clamp Kit (Rr. Shaft; Rr.)	UJ492-10			
1995	K1500 w/ Ext. Cab, Long Bed, Gas Eng. & MW3 Man. Trans.: [Type 14]		1995	K1500 w/ Ext. Cab, Long Bed & Diesel Eng. Exc. MW3 Man. Trans.: [Type 14]	
	U-Joint (Frnt. Shaft; Frt.) ①	UJ534G		U-Joint (Frnt. Shaft; Frt.) ①	UJ355
	Brute Force Greaseable	UJ235		Brute Force Greaseable	UJ290
	Brute Force Non Greaseable	UJ234		(For Aluminum Drive Shaft)	UJ355C
	Clamp Kit (Frnt. Shaft; Frt.)	UJ530-10		U-Joint (Frnt. Shaft; Rr.) ②	UJ354
	U-Joint (Frnt. Shaft; Rr.) ②	UJ534G		Brute Force Greaseable	UJ270
	Brute Force Greaseable	UJ235		Brute Force Non Greaseable	UJ254
	Brute Force Non Greaseable	UJ234		(For Aluminum Drive Shaft)	UJ354C
	Clamp Kit (Frnt. Shaft; Rr.)	UJ530-10		U-Joint (Rr. Shaft; Frt.) ③	UJ354
	U-Joint (Rr. Shaft; Frt.) ③	UJ331		Brute Force Greaseable	UJ270
	Brute Force Greaseable	UJ232		Brute Force Non Greaseable	UJ254
	Brute Force Non Greaseable	UJ231		(For Aluminum Drive Shaft)	UJ354C
	(For Aluminum Drive Shaft)	UJ331C		U-Joint (Rr. Shaft; Ctr.) ④	UJ354
	Clamp Kit (Rr. Shaft; Frt.)	UJ492-10		Brute Force Greaseable	UJ270
	U-Joint (Rr. Shaft; Ctr.) ④	UJ331		Brute Force Non Greaseable	UJ254
	Brute Force Greaseable	UJ232		(For Aluminum Drive Shaft)	UJ354C
	Brute Force Non Greaseable	UJ231		U-Joint (Rr. Shaft; Rr.) ⑤	UJ355
	(For Aluminum Drive Shaft)	UJ331C		Brute Force Greaseable	UJ290
	Clamp Kit (Rr. Shaft; Ctr.)	UJ492-10		(For Aluminum Drive Shaft)	UJ355C
	U-Joint (Rr. Shaft; Rr.) ⑤	UJ331		Clamp Kit (Rr. Shaft; Rr.)	UJ530-10
	Brute Force Greaseable	UJ232			
	Brute Force Non Greaseable	UJ231			
	(For Aluminum Drive Shaft)	UJ331C			
	Clamp Kit (Rr. Shaft; Rr.)	UJ492-10			

(Continued)

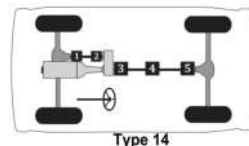

Passenger cars, light & medium trucks

Chevrolet/GMC Truck 1/2 ton -- (Cont.)

MFG./YEAR	MODEL & LOCATION	PART NO.	MFG./YEAR	MODEL & LOCATION	PART NO.
-----------	------------------	----------	-----------	------------------	----------

Drive Shaft (4 W/D) (Cont.)

U-Joint (Cont.)

1995	K1500 w/ Ext. Cab, Long Bed, Diesel	
	Eng. & HD Chassis: [Type 14]	
U-Joint (Fr. Shaft; Frt.) ⊙		UJ355
<i>Brute Force Greaseable</i>		<i>UJ290</i>
(For Aluminum Drive Shaft)		UJ355C
U-Joint (Fr. Shaft; Rr.) ⊙		UJ354
<i>Brute Force Greaseable</i>		<i>UJ270</i>
<i>Brute Force Non Greaseable</i>		<i>UJ254</i>
(For Aluminum Drive Shaft)		UJ354C
U-Joint (Rr. Shaft; Frt.) ⊙		UJ331
<i>Brute Force Greaseable</i>		<i>UJ232</i>
<i>Brute Force Non Greaseable</i>		<i>UJ231</i>
(For Aluminum Drive Shaft)		UJ331C
Clamp Kit (Rr. Shaft; Frt.)		UJ492-10
U-Joint (Rr. Shaft; Ctr.) ⊙		UJ331
<i>Brute Force Greaseable</i>		<i>UJ232</i>
<i>Brute Force Non Greaseable</i>		<i>UJ231</i>
(For Aluminum Drive Shaft)		UJ331C
Clamp Kit (Rr. Shaft; Ctr.)		UJ492-10
U-Joint (Rr. Shaft; Rr.) ⊙		UJ331
<i>Brute Force Greaseable</i>		<i>UJ232</i>
<i>Brute Force Non Greaseable</i>		<i>UJ231</i>
(For Aluminum Drive Shaft)		UJ331C
Clamp Kit (Rr. Shaft; Rr.)		UJ492-10
1995	K1500 w/ Ext. Cab, Long Bed, Diesel	
	Eng. & MW3 Man. Trans.: [Type 14]	
U-Joint (Fr. Shaft; Frt.) ⊙		UJ355
<i>Brute Force Greaseable</i>		<i>UJ290</i>
(For Aluminum Drive Shaft)		UJ355C
U-Joint (Fr. Shaft; Rr.) ⊙		UJ354
<i>Brute Force Greaseable</i>		<i>UJ270</i>
<i>Brute Force Non Greaseable</i>		<i>UJ254</i>
(For Aluminum Drive Shaft)		UJ354C
U-Joint (Rr. Shaft; Frt.) ⊙		UJ331
<i>Brute Force Greaseable</i>		<i>UJ232</i>
<i>Brute Force Non Greaseable</i>		<i>UJ231</i>
(For Aluminum Drive Shaft)		UJ331C
Clamp Kit (Rr. Shaft; Frt.)		UJ492-10
U-Joint (Rr. Shaft; Ctr.) ⊙		UJ331
<i>Brute Force Greaseable</i>		<i>UJ232</i>
<i>Brute Force Non Greaseable</i>		<i>UJ231</i>
(For Aluminum Drive Shaft)		UJ331C
Clamp Kit (Rr. Shaft; Ctr.)		UJ492-10
U-Joint (Rr. Shaft; Rr.) ⊙		UJ331
<i>Brute Force Greaseable</i>		<i>UJ232</i>
<i>Brute Force Non Greaseable</i>		<i>UJ231</i>
(For Aluminum Drive Shaft)		UJ331C
Clamp Kit (Rr. Shaft; Rr.)		UJ492-10

Drive Shaft (4 W/D) (Cont.)

U-Joint (Cont.)

1994	K1500 w/ Reg. Cab & Gas Eng. Exc.	
	MT8 Man. Trans.: [Type 13]	
U-Joint (Fr. Shaft; Frt.) ⊙		UJ534G
<i>Brute Force Greaseable</i>		<i>UJ235</i>
<i>Brute Force Non Greaseable</i>		<i>UJ234</i>
Clamp Kit (Fr. Shaft; Frt.)		UJ530-10
U-Joint (Fr. Shaft; Rr.) ⊙		UJ534G
<i>Brute Force Greaseable</i>		<i>UJ235</i>
<i>Brute Force Non Greaseable</i>		<i>UJ234</i>
Clamp Kit (Fr. Shaft; Rr.)		UJ530-10
U-Joint (Rr. Shaft; Frt.) ⊙		UJ534G
<i>Brute Force Greaseable</i>		<i>UJ235</i>
<i>Brute Force Non Greaseable</i>		<i>UJ234</i>
Clamp Kit (Rr. Shaft; Frt.)		UJ530-10
U-Joint (Rr. Shaft; Rr.) ⊙		UJ534G
<i>Brute Force Greaseable</i>		<i>UJ235</i>
<i>Brute Force Non Greaseable</i>		<i>UJ234</i>
Clamp Kit (Rr. Shaft; Rr.)		UJ530-10
1994	K1500 w/ Reg. Cab, Gas Eng. & MT8	
	Man. Trans.: [Type 13]	
U-Joint (Fr. Shaft; Frt.) ⊙		UJ534G
<i>Brute Force Greaseable</i>		<i>UJ235</i>
<i>Brute Force Non Greaseable</i>		<i>UJ234</i>
Clamp Kit (Fr. Shaft; Frt.)		UJ530-10
U-Joint (Fr. Shaft; Rr.) ⊙		UJ534G
<i>Brute Force Greaseable</i>		<i>UJ235</i>
<i>Brute Force Non Greaseable</i>		<i>UJ234</i>
Clamp Kit (Fr. Shaft; Rr.)		UJ530-10
U-Joint (Rr. Shaft; Frt.) ⊙		UJ331
<i>Brute Force Greaseable</i>		<i>UJ232</i>
<i>Brute Force Non Greaseable</i>		<i>UJ231</i>
(For Aluminum Drive Shaft)		UJ331C
Clamp Kit (Rr. Shaft; Frt.)		UJ492-10
U-Joint (Rr. Shaft; Rr.) ⊙		UJ331
<i>Brute Force Greaseable</i>		<i>UJ232</i>
<i>Brute Force Non Greaseable</i>		<i>UJ231</i>
(For Aluminum Drive Shaft)		UJ331C
Clamp Kit (Rr. Shaft; Rr.)		UJ492-10

(Continued)

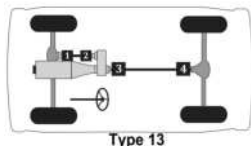

Type 13

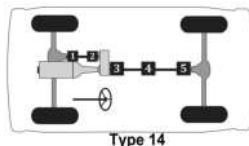

Type 14

Passenger cars, light & medium trucks

(Cont.) -- Chevrolet/GMC Truck 1/2 ton

MFG./YEAR	MODEL & LOCATION	PART NO.	MFG./YEAR	MODEL & LOCATION	PART NO.
Drive Shaft (4 W/D) (Cont.)			Drive Shaft (4 W/D) (Cont.)		
U-Joint (Cont.)			U-Joint (Cont.)		
1994	K1500 w/ Reg. Cab & Diesel Eng. Exc. MT8 Man. Trans.: [Type 13]		1994	K1500 w/ Ext. Cab, Short Bed & Gas Eng. Exc. MT8 Man. Trans.: [Type 13]	
	U-Joint (Fr. Shaft; Frt.) Ⓢ	UJ355		U-Joint (Fr. Shaft; Frt.) Ⓢ	UJ534G
	<i>Brute Force Greaseable</i>	UJ290		<i>Brute Force Greaseable</i>	UJ235
	(For Aluminum Drive Shaft)	UJ355C		<i>Brute Force Non Greaseable</i>	UJ234
	U-Joint (Fr. Shaft; Rr.) Ⓢ	UJ354		Clamp Kit (Fr. Shaft; Frt.)	UJ530-10
	<i>Brute Force Greaseable</i>	UJ270		U-Joint (Fr. Shaft; Rr.) Ⓢ	UJ534G
	<i>Brute Force Non Greaseable</i>	UJ254		<i>Brute Force Greaseable</i>	UJ235
	(For Aluminum Drive Shaft)	UJ354C		<i>Brute Force Non Greaseable</i>	UJ234
	U-Joint (Rr. Shaft; Frt.) Ⓢ	UJ534G		Clamp Kit (Fr. Shaft; Rr.)	UJ530-10
	<i>Brute Force Greaseable</i>	UJ235		U-Joint (Rr. Shaft; Frt.) Ⓢ	UJ354
	<i>Brute Force Non Greaseable</i>	UJ234		<i>Brute Force Greaseable</i>	UJ270
	Clamp Kit (Rr. Shaft; Frt.)	UJ530-10		<i>Brute Force Non Greaseable</i>	UJ254
	U-Joint (Rr. Shaft; Rr.) Ⓢ	UJ534G		(For Aluminum Drive Shaft)	UJ354C
	<i>Brute Force Greaseable</i>	UJ235		U-Joint (Rr. Shaft; Rr.) Ⓢ	UJ355
	<i>Brute Force Non Greaseable</i>	UJ234		<i>Brute Force Greaseable</i>	UJ290
	Clamp Kit (Rr. Shaft; Rr.)	UJ530-10		(For Aluminum Drive Shaft)	UJ355C
1994	K1500 w/ Reg. Cab, Diesel Eng. & MT8 Man. Trans.: [Type 13]		1994	K1500 w/ Ext. Cab, Short Bed & Gas Eng. w/o HD Chassis: [Type 13]	
	U-Joint (Fr. Shaft; Frt.) Ⓢ	UJ355		U-Joint (Fr. Shaft; Frt.) Ⓢ	UJ355
	<i>Brute Force Greaseable</i>	UJ290		<i>Brute Force Greaseable</i>	UJ290
	(For Aluminum Drive Shaft)	UJ355C		(For Aluminum Drive Shaft)	UJ355C
	U-Joint (Fr. Shaft; Rr.) Ⓢ	UJ354		U-Joint (Fr. Shaft; Rr.) Ⓢ	UJ354
	<i>Brute Force Greaseable</i>	UJ270		<i>Brute Force Greaseable</i>	UJ270
	<i>Brute Force Non Greaseable</i>	UJ254		<i>Brute Force Non Greaseable</i>	UJ254
	(For Aluminum Drive Shaft)	UJ354C		(For Aluminum Drive Shaft)	UJ354C
	U-Joint (Rr. Shaft; Frt.) Ⓢ	UJ331		U-Joint (Rr. Shaft; Frt.) Ⓢ	UJ354
	<i>Brute Force Greaseable</i>	UJ232		<i>Brute Force Greaseable</i>	UJ270
	<i>Brute Force Non Greaseable</i>	UJ231		<i>Brute Force Non Greaseable</i>	UJ254
	(For Aluminum Drive Shaft)	UJ331C		(For Aluminum Drive Shaft)	UJ354C
	Clamp Kit (Rr. Shaft; Frt.)	UJ492-10		U-Joint (Rr. Shaft; Rr.) Ⓢ	UJ355
	U-Joint (Rr. Shaft; Rr.) Ⓢ	UJ331		<i>Brute Force Greaseable</i>	UJ290
	<i>Brute Force Greaseable</i>	UJ232		(For Aluminum Drive Shaft)	UJ355C
	<i>Brute Force Non Greaseable</i>	UJ231		Clamp Kit (Rr. Shaft; Rr.)	UJ530-10
	(For Aluminum Drive Shaft)	UJ331C			(Continued)
	Clamp Kit (Rr. Shaft; Rr.)	UJ492-10			

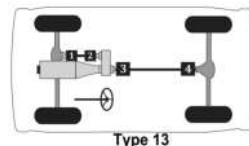

Passenger cars, light & medium trucks

Chevrolet/GMC Truck 1/2 ton -- (Cont.)

MFG./YEAR	MODEL & LOCATION	PART NO.	MFG./YEAR	MODEL & LOCATION	PART NO.
Drive Shaft (4 W/D) (Cont.)			Drive Shaft (4 W/D) (Cont.)		
U-Joint (Cont.)			U-Joint (Cont.)		
1994	K1500 w/ Ext. Cab, Short Bed, Gas Eng. & HD Chassis: [Type 13]		1994	K1500 w/ Ext. Cab, Short Bed, Diesel Eng. & HD Chassis: [Type 13]	
	U-Joint (Frt. Shaft; Frt.) ⊙	UJ534G		U-Joint (Frt. Shaft; Frt.) ⊙	UJ355
	<i>Brute Force Greaseable</i>	UJ235		<i>Brute Force Greaseable</i>	UJ290
	<i>Brute Force Non Greaseable</i>	UJ234		(For Aluminum Drive Shaft)	UJ355C
	Clamp Kit (Frt. Shaft; Frt.)	UJ530-10		U-Joint (Frt. Shaft; Rr.) ⊙	UJ354
	U-Joint (Frt. Shaft; Rr.) ⊙	UJ534G		<i>Brute Force Greaseable</i>	UJ270
	<i>Brute Force Greaseable</i>	UJ235		<i>Brute Force Non Greaseable</i>	UJ254
	<i>Brute Force Non Greaseable</i>	UJ234		(For Aluminum Drive Shaft)	UJ354C
	Clamp Kit (Frt. Shaft; Rr.)	UJ530-10		U-Joint (Rr. Shaft; Frt.) ⊙	UJ331
	U-Joint (Rr. Shaft; Frt.) ⊙	UJ331		<i>Brute Force Greaseable</i>	UJ232
	<i>Brute Force Greaseable</i>	UJ232		<i>Brute Force Non Greaseable</i>	UJ231
	<i>Brute Force Non Greaseable</i>	UJ231		(For Aluminum Drive Shaft)	UJ331C
	(For Aluminum Drive Shaft)	UJ331C		Clamp Kit (Rr. Shaft; Frt.)	UJ492-10
	Clamp Kit (Rr. Shaft; Frt.)	UJ492-10		U-Joint (Rr. Shaft; Rr.) ⊙	UJ331
	U-Joint (Rr. Shaft; Rr.) ⊙	UJ331		<i>Brute Force Greaseable</i>	UJ232
	<i>Brute Force Greaseable</i>	UJ232		<i>Brute Force Non Greaseable</i>	UJ231
	<i>Brute Force Non Greaseable</i>	UJ231		(For Aluminum Drive Shaft)	UJ331C
	(For Aluminum Drive Shaft)	UJ331C		Clamp Kit (Rr. Shaft; Rr.)	UJ492-10
	Clamp Kit (Rr. Shaft; Rr.)	UJ492-10	1994	K1500 w/ Ext. Cab, Short Bed, Diesel Eng. w/o HD Chassis: [Type 13]	
1994	K1500 w/ Ext. Cab, Short Bed, Gas Eng. & MT8 Man. Trans.: [Type 13]			U-Joint (Frt. Shaft; Frt.) ⊙	UJ355
	U-Joint (Frt. Shaft; Frt.) ⊙	UJ534G		<i>Brute Force Greaseable</i>	UJ290
	<i>Brute Force Greaseable</i>	UJ235		(For Aluminum Drive Shaft)	UJ355C
	<i>Brute Force Non Greaseable</i>	UJ234		U-Joint (Frt. Shaft; Rr.) ⊙	UJ354
	Clamp Kit (Frt. Shaft; Frt.)	UJ530-10		<i>Brute Force Greaseable</i>	UJ270
	U-Joint (Frt. Shaft; Rr.) ⊙	UJ534G		<i>Brute Force Non Greaseable</i>	UJ254
	<i>Brute Force Greaseable</i>	UJ235		(For Aluminum Drive Shaft)	UJ354C
	<i>Brute Force Non Greaseable</i>	UJ234		U-Joint (Rr. Shaft; Frt.) ⊙	UJ354
	Clamp Kit (Frt. Shaft; Rr.)	UJ530-10		<i>Brute Force Greaseable</i>	UJ270
	U-Joint (Rr. Shaft; Frt.) ⊙	UJ331		<i>Brute Force Non Greaseable</i>	UJ254
	<i>Brute Force Greaseable</i>	UJ232		(For Aluminum Drive Shaft)	UJ354C
	<i>Brute Force Non Greaseable</i>	UJ231		U-Joint (Rr. Shaft; Rr.) ⊙	UJ355
	(For Aluminum Drive Shaft)	UJ331C		<i>Brute Force Greaseable</i>	UJ290
	Clamp Kit (Rr. Shaft; Frt.)	UJ492-10		(For Aluminum Drive Shaft)	UJ355C
	U-Joint (Rr. Shaft; Rr.) ⊙	UJ331		Clamp Kit (Rr. Shaft; Rr.)	UJ530-10
	<i>Brute Force Greaseable</i>	UJ232			(Continued)
	<i>Brute Force Non Greaseable</i>	UJ231			
	(For Aluminum Drive Shaft)	UJ331C			
	Clamp Kit (Rr. Shaft; Rr.)	UJ492-10			

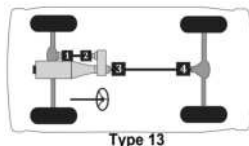

144 ▲ For Use w/ 1.063" Bearing Cap Application. ⊙ For Use w/ 1.188" Bearing Cap Application. ◇ For Use w/ Inner Lock Ring Application on Half Shaft. □ For Use w/ Outer Lock Ring Application on Half Shaft.

Passenger cars, light & medium trucks

(Cont.) -- Chevrolet/GMC Truck 1/2 ton

MFG./YEAR	MODEL & LOCATION	PART NO.	MFG./YEAR	MODEL & LOCATION	PART NO.
Drive Shaft (4 W/D) (Cont.)			Drive Shaft (4 W/D) (Cont.)		
U-Joint (Cont.)			U-Joint (Cont.)		
1994	K1500 w/ Ext. Cab, Short Bed, Diesel Eng. & MT8 Man. Trans.: [Type 13]		1994	K1500 w/ Ext. Cab, Long Bed & Gas Eng. w/o HD Chassis: [Type 14]	
	U-Joint (Fr. Shaft; Fr.) ^①	UJ355		U-Joint (Fr. Shaft; Fr.) ^①	UJ534G
	Brute Force Greaseable	UJ290		Brute Force Greaseable	UJ235
	(For Aluminum Drive Shaft)	UJ355C		Brute Force Non Greaseable	UJ234
	U-Joint (Fr. Shaft; Rr.) ^②	UJ354		Clamp Kit (Fr. Shaft; Fr.)	UJ530-10
	Brute Force Greaseable	UJ270		U-Joint (Fr. Shaft; Rr.) ^②	UJ534G
	Brute Force Non Greaseable	UJ254		Brute Force Greaseable	UJ235
	(For Aluminum Drive Shaft)	UJ354C		Brute Force Non Greaseable	UJ234
	U-Joint (Rr. Shaft; Fr.) ^③	UJ331		Clamp Kit (Fr. Shaft; Rr.)	UJ530-10
	Brute Force Greaseable	UJ232		U-Joint (Rr. Shaft; Fr.) ^③	UJ354
	Brute Force Non Greaseable	UJ231		Brute Force Greaseable	UJ270
	(For Aluminum Drive Shaft)	UJ331C		Brute Force Non Greaseable	UJ254
	Clamp Kit (Rr. Shaft; Fr.)	UJ492-10		(For Aluminum Drive Shaft)	UJ354C
	U-Joint (Rr. Shaft; Rr.) ^④	UJ331		U-Joint (Rr. Shaft; Ctr.) ^④	UJ354
	Brute Force Greaseable	UJ232		Brute Force Greaseable	UJ270
	Brute Force Non Greaseable	UJ231		Brute Force Non Greaseable	UJ254
	(For Aluminum Drive Shaft)	UJ331C		(For Aluminum Drive Shaft)	UJ354C
	Clamp Kit (Rr. Shaft; Rr.)	UJ492-10		U-Joint (Rr. Shaft; Rr.) ^⑤	UJ355
1994	K1500 w/ Ext. Cab, Short Bed & Diesel Eng. Exc. MT8 Man. Trans.: [Type 13]			Brute Force Greaseable	UJ290
	U-Joint (Fr. Shaft; Fr.) ^①	UJ355	1994	K1500 w/ Ext. Cab, Long Bed & Gas Eng. Exc. MT8 Man. Trans.: [Type 14]	
	Brute Force Greaseable	UJ290		U-Joint (Fr. Shaft; Fr.) ^①	UJ534G
	(For Aluminum Drive Shaft)	UJ355C		Brute Force Greaseable	UJ235
	U-Joint (Fr. Shaft; Rr.) ^②	UJ354		Brute Force Non Greaseable	UJ234
	Brute Force Greaseable	UJ270		Clamp Kit (Fr. Shaft; Fr.)	UJ530-10
	Brute Force Non Greaseable	UJ254		U-Joint (Fr. Shaft; Rr.) ^②	UJ534G
	(For Aluminum Drive Shaft)	UJ354C		Brute Force Greaseable	UJ235
	U-Joint (Rr. Shaft; Fr.) ^③	UJ354		Brute Force Non Greaseable	UJ234
	Brute Force Greaseable	UJ270		Clamp Kit (Fr. Shaft; Rr.)	UJ530-10
	Brute Force Non Greaseable	UJ254		U-Joint (Rr. Shaft; Fr.) ^③	UJ354
	(For Aluminum Drive Shaft)	UJ354C		Brute Force Greaseable	UJ270
	U-Joint (Rr. Shaft; Rr.) ^④	UJ355		Brute Force Non Greaseable	UJ254
	Brute Force Greaseable	UJ290		(For Aluminum Drive Shaft)	UJ354C
	(For Aluminum Drive Shaft)	UJ355C		U-Joint (Rr. Shaft; Ctr.) ^④	UJ354
	Clamp Kit (Rr. Shaft; Rr.)	UJ530-10		Brute Force Greaseable	UJ270
				Brute Force Non Greaseable	UJ254
				(For Aluminum Drive Shaft)	UJ354C
				U-Joint (Rr. Shaft; Rr.) ^⑤	UJ355
				Brute Force Greaseable	UJ290
				(For Aluminum Drive Shaft)	UJ355C
				Clamp Kit (Rr. Shaft; Rr.)	UJ530-10

(Continued)

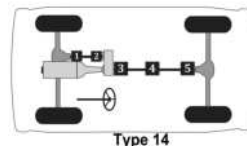
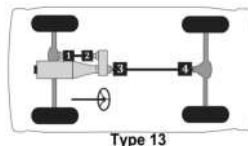

Passenger cars, light & medium trucks

Chevrolet/GMC Truck 1/2 ton -- (Cont.)

MFG./YEAR	MODEL & LOCATION	PART NO.	MFG./YEAR	MODEL & LOCATION	PART NO.
Drive Shaft (4 W/D) (Cont.)			Drive Shaft (4 W/D) (Cont.)		
U-Joint (Cont.)			U-Joint (Cont.)		
1994	K1500 w/ Ext. Cab, Long Bed & Diesel Eng. Exc. MT8 Man. Trans.: [Type 14]		1994	K1500 w/ Ext. Cab, Long Bed, Gas Eng. & HD Chassis: [Type 14]	
	U-Joint (Fr. Shaft; Frt.)⊙	UJ355		U-Joint (Fr. Shaft; Frt.)⊙	UJ534G
	Brute Force Greaseable	UJ290		Brute Force Greaseable	UJ235
	(For Aluminum Drive Shaft)	UJ355C		Brute Force Non Greaseable	UJ234
	U-Joint (Fr. Shaft; Rr.)⊙	UJ354		Clamp Kit (Fr. Shaft; Frt.)	UJ530-10
	Brute Force Greaseable	UJ270		U-Joint (Fr. Shaft; Rr.)⊙	UJ534G
	Brute Force Non Greaseable	UJ254		Brute Force Greaseable	UJ235
	(For Aluminum Drive Shaft)	UJ354C		Brute Force Non Greaseable	UJ234
	U-Joint (Rr. Shaft; Frt.)⊙	UJ354		Clamp Kit (Fr. Shaft; Rr.)	UJ530-10
	Brute Force Greaseable	UJ270		U-Joint (Rr. Shaft; Frt.)⊙	UJ331
	Brute Force Non Greaseable	UJ254		Brute Force Greaseable	UJ232
	(For Aluminum Drive Shaft)	UJ354C		Brute Force Non Greaseable	UJ231
	U-Joint (Rr. Shaft; Ctr.)⊙	UJ354		(For Aluminum Drive Shaft)	UJ331C
	Brute Force Greaseable	UJ270		Clamp Kit (Rr. Shaft; Frt.)	UJ492-10
	Brute Force Non Greaseable	UJ254		U-Joint (Rr. Shaft; Ctr.)⊙	UJ331
	(For Aluminum Drive Shaft)	UJ354C		Brute Force Greaseable	UJ232
	U-Joint (Rr. Shaft; Rr.)⊙	UJ355		Brute Force Non Greaseable	UJ231
	Brute Force Greaseable	UJ290		(For Aluminum Drive Shaft)	UJ331C
	(For Aluminum Drive Shaft)	UJ355C		Clamp Kit (Rr. Shaft; Ctr.)	UJ492-10
	Clamp Kit (Rr. Shaft; Rr.)	UJ530-10		U-Joint (Rr. Shaft; Rr.)⊙	UJ331
1994	K1500 w/ Ext. Cab, Long Bed & Diesel Eng. w/o HD Chassis: [Type 14]		1994	K1500 w/ Ext. Cab, Long Bed, Gas Eng. & MT8 Man. Trans.: [Type 14]	
	U-Joint (Fr. Shaft; Frt.)⊙	UJ355		U-Joint (Fr. Shaft; Frt.)⊙	UJ534G
	Brute Force Greaseable	UJ290		Brute Force Greaseable	UJ235
	(For Aluminum Drive Shaft)	UJ355C		Brute Force Non Greaseable	UJ234
	U-Joint (Fr. Shaft; Rr.)⊙	UJ354		Clamp Kit (Fr. Shaft; Frt.)	UJ530-10
	Brute Force Greaseable	UJ270		U-Joint (Fr. Shaft; Rr.)⊙	UJ534G
	Brute Force Non Greaseable	UJ254		Brute Force Greaseable	UJ235
	(For Aluminum Drive Shaft)	UJ354C		Brute Force Non Greaseable	UJ234
	U-Joint (Rr. Shaft; Frt.)⊙	UJ354		Clamp Kit (Fr. Shaft; Rr.)	UJ530-10
	Brute Force Greaseable	UJ270		U-Joint (Rr. Shaft; Frt.)⊙	UJ331
	Brute Force Non Greaseable	UJ254		Brute Force Greaseable	UJ232
	(For Aluminum Drive Shaft)	UJ354C		Brute Force Non Greaseable	UJ231
	U-Joint (Rr. Shaft; Ctr.)⊙	UJ354		(For Aluminum Drive Shaft)	UJ331C
	Brute Force Greaseable	UJ270		Clamp Kit (Rr. Shaft; Frt.)	UJ492-10
	Brute Force Non Greaseable	UJ254		U-Joint (Rr. Shaft; Ctr.)⊙	UJ331
	(For Aluminum Drive Shaft)	UJ354C		Brute Force Greaseable	UJ232
	U-Joint (Rr. Shaft; Rr.)⊙	UJ355		Brute Force Non Greaseable	UJ231
	Brute Force Greaseable	UJ290		(For Aluminum Drive Shaft)	UJ331C
	(For Aluminum Drive Shaft)	UJ355C		Clamp Kit (Rr. Shaft; Ctr.)	UJ492-10
	Clamp Kit (Rr. Shaft; Rr.)	UJ530-10		U-Joint (Rr. Shaft; Rr.)⊙	UJ331
				Brute Force Greaseable	UJ232
				Brute Force Non Greaseable	UJ231
				(For Aluminum Drive Shaft)	UJ331C
				Clamp Kit (Rr. Shaft; Rr.)	UJ492-10
				U-Joint (Rr. Shaft; Rr.)⊙	UJ331
				Brute Force Greaseable	UJ232
				Brute Force Non Greaseable	UJ231
				(For Aluminum Drive Shaft)	UJ331C
				Clamp Kit (Rr. Shaft; Rr.)	UJ492-10

(Continued)

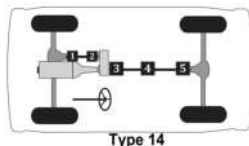

Passenger cars, light & medium trucks

(Cont.) -- Chevrolet/GMC Truck 1/2 ton

MFG./YEAR	MODEL & LOCATION	PART NO.	MFG./YEAR	MODEL & LOCATION	PART NO.
Drive Shaft (4 W/D) (Cont.)			Drive Shaft (4 W/D) (Cont.)		
U-Joint (Cont.)			U-Joint (Cont.)		
1994	K1500 w/ Ext. Cab, Long Bed, Diesel Eng. & HD Chassis: [Type 14]		1994-1992	Blazer: [Type 13]	
	U-Joint (Frnt. Shaft; Frt.) ①	UJ355		U-Joint (Frnt. Shaft; Frt.) ①	UJ534G
	<i>Brute Force Greaseable</i>	UJ290		<i>Brute Force Greaseable</i>	UJ235
	(For Aluminum Drive Shaft)	UJ355C		<i>Brute Force Non Greaseable</i>	UJ234
	U-Joint (Frnt. Shaft; Rr.) ②	UJ354		Clamp Kit (Frnt. Shaft; Frt.)	UJ530-10
	<i>Brute Force Greaseable</i>	UJ270		U-Joint (Frnt. Shaft; Rr.) ②	UJ534G
	<i>Brute Force Non Greaseable</i>	UJ254		<i>Brute Force Greaseable</i>	UJ235
	(For Aluminum Drive Shaft)	UJ354C		<i>Brute Force Non Greaseable</i>	UJ234
	U-Joint (Rr. Shaft; Frt.) ③	UJ331		Clamp Kit (Frnt. Shaft; Rr.)	UJ530-10
	<i>Brute Force Greaseable</i>	UJ232		U-Joint (Rr. Shaft; Frt.) ③	UJ534G
	<i>Brute Force Non Greaseable</i>	UJ231		<i>Brute Force Greaseable</i>	UJ235
	(For Aluminum Drive Shaft)	UJ331C		<i>Brute Force Non Greaseable</i>	UJ234
	Clamp Kit (Rr. Shaft; Frt.)	UJ492-10		Clamp Kit (Rr. Shaft; Frt.)	UJ530-10
	U-Joint (Rr. Shaft; Ctr.) ④	UJ331		U-Joint (Rr. Shaft; Rr.) ④	UJ534G
	<i>Brute Force Greaseable</i>	UJ232		<i>Brute Force Greaseable</i>	UJ235
	<i>Brute Force Non Greaseable</i>	UJ231		<i>Brute Force Non Greaseable</i>	UJ234
	(For Aluminum Drive Shaft)	UJ331C		Clamp Kit (Rr. Shaft; Rr.)	UJ530-10
	Clamp Kit (Rr. Shaft; Ctr.)	UJ492-10		1993-1992 Suburban: [Type 13]	
	U-Joint (Rr. Shaft; Rr.) ⑤	UJ331		U-Joint (Frnt. Shaft; Frt.) ①	UJ534G
	<i>Brute Force Greaseable</i>	UJ232		<i>Brute Force Greaseable</i>	UJ235
	<i>Brute Force Non Greaseable</i>	UJ231		<i>Brute Force Non Greaseable</i>	UJ234
	(For Aluminum Drive Shaft)	UJ331C		Clamp Kit (Frnt. Shaft; Frt.)	UJ530-10
	Clamp Kit (Rr. Shaft; Rr.)	UJ492-10		U-Joint (Frnt. Shaft; Rr.) ②	UJ534G
1994	K1500 w/ Ext. Cab, Long Bed, Diesel Eng. & MT8 Man. Trans.: [Type 14]			<i>Brute Force Greaseable</i>	UJ235
	U-Joint (Frnt. Shaft; Frt.) ①	UJ355		<i>Brute Force Non Greaseable</i>	UJ234
	<i>Brute Force Greaseable</i>	UJ290		Clamp Kit (Frnt. Shaft; Frt.)	UJ530-10
	(For Aluminum Drive Shaft)	UJ355C		U-Joint (Rr. Shaft; Frt.) ③	UJ534G
	U-Joint (Frnt. Shaft; Rr.) ②	UJ354		<i>Brute Force Greaseable</i>	UJ235
	<i>Brute Force Greaseable</i>	UJ270		<i>Brute Force Non Greaseable</i>	UJ234
	<i>Brute Force Non Greaseable</i>	UJ254		Clamp Kit (Rr. Shaft; Frt.)	UJ530-10
	(For Aluminum Drive Shaft)	UJ354C		U-Joint (Rr. Shaft; Rr.) ④	UJ534G
	U-Joint (Rr. Shaft; Frt.) ③	UJ331		<i>Brute Force Greaseable</i>	UJ235
	<i>Brute Force Greaseable</i>	UJ232		<i>Brute Force Non Greaseable</i>	UJ234
	<i>Brute Force Non Greaseable</i>	UJ231		Clamp Kit (Rr. Shaft; Rr.)	UJ530-10
	(For Aluminum Drive Shaft)	UJ331C			(Continued)
	Clamp Kit (Rr. Shaft; Frt.)	UJ492-10			
	U-Joint (Rr. Shaft; Ctr.) ④	UJ331			
	<i>Brute Force Greaseable</i>	UJ232			
	<i>Brute Force Non Greaseable</i>	UJ231			
	(For Aluminum Drive Shaft)	UJ331C			
	Clamp Kit (Rr. Shaft; Ctr.)	UJ492-10			
	U-Joint (Rr. Shaft; Rr.) ⑤	UJ331			
	<i>Brute Force Greaseable</i>	UJ232			
	<i>Brute Force Non Greaseable</i>	UJ231			
	(For Aluminum Drive Shaft)	UJ331C			
	Clamp Kit (Rr. Shaft; Rr.)	UJ492-10			

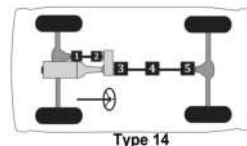
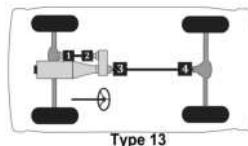

Passenger cars, light & medium trucks

Chevrolet/GMC Truck 1/2 ton -- (Cont.)

MFG./YEAR	MODEL & LOCATION	PART NO.	MFG./YEAR	MODEL & LOCATION	PART NO.
Drive Shaft (4 W/D) (Cont.)			Drive Shaft (4 W/D) (Cont.)		
U-Joint (Cont.)			U-Joint (Cont.)		
1993-1992 K1500 w/ Reg. Cab & MT8 Man.			1993-1992 K1500 w/ Ext. Cab & Short Bed w/o HD		
Trans.: [Type 13]			Chassis: [Type 13]		
U-Joint (Fr. Shaft; Frt.) [⊙]		UJ534G	U-Joint (Fr. Shaft; Frt.) [⊙]		UJ534G
Brute Force Greaseable		UJ235	Brute Force Greaseable		UJ235
Brute Force Non Greaseable		UJ234	Brute Force Non Greaseable		UJ234
Clamp Kit (Fr. Shaft; Frt.)		UJ530-10	Clamp Kit (Fr. Shaft; Frt.)		UJ530-10
U-Joint (Fr. Shaft; Rr.) [⊙]		UJ534G	U-Joint (Fr. Shaft; Rr.) [⊙]		UJ534G
Brute Force Greaseable		UJ235	Brute Force Greaseable		UJ235
Brute Force Non Greaseable		UJ234	Brute Force Non Greaseable		UJ234
Clamp Kit (Fr. Shaft; Rr.)		UJ530-10	Clamp Kit (Fr. Shaft; Rr.)		UJ530-10
U-Joint (Rr. Shaft; Frt.) [⊙]		UJ331	U-Joint (Rr. Shaft; Frt.) [⊙]		UJ354
Brute Force Greaseable		UJ232	Brute Force Greaseable		UJ270
Brute Force Non Greaseable		UJ231	Brute Force Non Greaseable		UJ254
(For Aluminum Drive Shaft)		UJ331C	(For Aluminum Drive Shaft)		UJ354C
Clamp Kit (Rr. Shaft; Frt.)		UJ492-10	U-Joint (Rr. Shaft; Rr.) [⊙]		UJ355
U-Joint (Rr. Shaft; Rr.) [⊙]		UJ331	Brute Force Greaseable		UJ290
Brute Force Greaseable		UJ232	(For Aluminum Drive Shaft)		UJ355C
Brute Force Non Greaseable		UJ231	Clamp Kit (Rr. Shaft; Rr.)		UJ530-10
(For Aluminum Drive Shaft)		UJ331C	1993-1992 K1500 w/ Ext. Cab & Short Bed Exc.		
Clamp Kit (Rr. Shaft; Rr.)		UJ492-10	MT8 Man. Trans.: [Type 13]		
1993-1992 K1500 w/ Reg. Cab Exc. MT8 Man.			U-Joint (Fr. Shaft; Frt.) [⊙]		UJ534G
Trans.: [Type 13]			Brute Force Greaseable		UJ235
U-Joint (Fr. Shaft; Frt.) [⊙]		UJ534G	Brute Force Non Greaseable		UJ234
Brute Force Greaseable		UJ235	Clamp Kit (Fr. Shaft; Frt.)		UJ530-10
Brute Force Non Greaseable		UJ234	U-Joint (Fr. Shaft; Rr.) [⊙]		UJ534G
Clamp Kit (Fr. Shaft; Frt.)		UJ530-10	Brute Force Greaseable		UJ235
U-Joint (Fr. Shaft; Rr.) [⊙]		UJ534G	Brute Force Non Greaseable		UJ234
Brute Force Greaseable		UJ235	Clamp Kit (Fr. Shaft; Rr.)		UJ530-10
Brute Force Non Greaseable		UJ234	U-Joint (Rr. Shaft; Frt.) [⊙]		UJ354
Clamp Kit (Fr. Shaft; Rr.)		UJ530-10	Brute Force Greaseable		UJ270
U-Joint (Rr. Shaft; Frt.) [⊙]		UJ534G	Brute Force Non Greaseable		UJ254
Brute Force Greaseable		UJ235	(For Aluminum Drive Shaft)		UJ354C
Brute Force Non Greaseable		UJ234	U-Joint (Rr. Shaft; Rr.) [⊙]		UJ355
Clamp Kit (Rr. Shaft; Frt.)		UJ530-10	Brute Force Greaseable		UJ290
U-Joint (Rr. Shaft; Rr.) [⊙]		UJ534G	(For Aluminum Drive Shaft)		UJ355C
Brute Force Greaseable		UJ235	Clamp Kit (Rr. Shaft; Rr.)		UJ530-10
Brute Force Non Greaseable		UJ234			(Continued)
Clamp Kit (Rr. Shaft; Rr.)		UJ530-10			

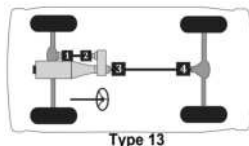

148 ▲ For Use w/ 1.063" Bearing Cap Application. ⊙ For Use w/ 1.188" Bearing Cap Application. ◇ For Use w/ Inner Lock Ring Application on Half Shaft. □ For Use w/ Outer Lock Ring Application on Half Shaft.

Passenger cars, light & medium trucks

(Cont.) -- Chevrolet/GMC Truck 1/2 ton

MFG./YEAR	MODEL & LOCATION	PART NO.	MFG./YEAR	MODEL & LOCATION	PART NO.
Drive Shaft (4 W/D) (Cont.)			Drive Shaft (4 W/D) (Cont.)		
U-Joint (Cont.)			U-Joint (Cont.)		
1993-1992 K1500 w/ Ext. Cab, Short Bed & HD			1993-1992 K1500 w/ Ext. Cab, Long Bed & MT8		
Chassis: [Type 13]			Man. Trans.: [Type 14]		
U-Joint (Fr. Shaft; Frt.) ①		UJ534G	U-Joint (Fr. Shaft; Frt.) ①		UJ534G
<i>Brute Force Greaseable</i>		UJ235	<i>Brute Force Greaseable</i>		UJ235
<i>Brute Force Non Greaseable</i>		UJ234	<i>Brute Force Non Greaseable</i>		UJ234
Clamp Kit (Fr. Shaft; Frt.)		UJ530-10	Clamp Kit (Fr. Shaft; Frt.)		UJ530-10
U-Joint (Fr. Shaft; Rr.) ②		UJ534G	U-Joint (Fr. Shaft; Rr.) ②		UJ534G
<i>Brute Force Greaseable</i>		UJ235	<i>Brute Force Greaseable</i>		UJ235
<i>Brute Force Non Greaseable</i>		UJ234	<i>Brute Force Non Greaseable</i>		UJ234
Clamp Kit (Fr. Shaft; Rr.)		UJ530-10	Clamp Kit (Fr. Shaft; Rr.)		UJ530-10
U-Joint (Rr. Shaft; Frt.) ③		UJ331	U-Joint (Rr. Shaft; Frt.) ③		UJ331
<i>Brute Force Greaseable</i>		UJ232	<i>Brute Force Greaseable</i>		UJ232
<i>Brute Force Non Greaseable</i>		UJ231	<i>Brute Force Non Greaseable</i>		UJ231
(For Aluminum Drive Shaft)		UJ331C	(For Aluminum Drive Shaft)		UJ331C
Clamp Kit (Rr. Shaft; Frt.)		UJ492-10	Clamp Kit (Rr. Shaft; Frt.)		UJ492-10
U-Joint (Rr. Shaft; Rr.) ④		UJ331	U-Joint (Rr. Shaft; Rr.) ④		UJ331
<i>Brute Force Greaseable</i>		UJ232	<i>Brute Force Greaseable</i>		UJ232
<i>Brute Force Non Greaseable</i>		UJ231	<i>Brute Force Non Greaseable</i>		UJ231
(For Aluminum Drive Shaft)		UJ331C	(For Aluminum Drive Shaft)		UJ331C
Clamp Kit (Rr. Shaft; Rr.)		UJ492-10	Clamp Kit (Rr. Shaft; Rr.)		UJ492-10
1993-1992 K1500 w/ Ext. Cab, Short Bed & MT8			1993-1992 K1500 w/ Ext. Cab, Long Bed & HD		
Man. Trans.: [Type 13]			Chassis: [Type 14]		
U-Joint (Fr. Shaft; Frt.) ①		UJ534G	U-Joint (Fr. Shaft; Frt.) ①		UJ534G
<i>Brute Force Greaseable</i>		UJ235	<i>Brute Force Greaseable</i>		UJ235
<i>Brute Force Non Greaseable</i>		UJ234	<i>Brute Force Non Greaseable</i>		UJ234
Clamp Kit (Fr. Shaft; Frt.)		UJ530-10	Clamp Kit (Fr. Shaft; Frt.)		UJ530-10
U-Joint (Fr. Shaft; Rr.) ②		UJ534G	U-Joint (Fr. Shaft; Rr.) ②		UJ534G
<i>Brute Force Greaseable</i>		UJ235	<i>Brute Force Greaseable</i>		UJ235
<i>Brute Force Non Greaseable</i>		UJ234	<i>Brute Force Non Greaseable</i>		UJ234
Clamp Kit (Fr. Shaft; Rr.)		UJ530-10	Clamp Kit (Fr. Shaft; Rr.)		UJ530-10
U-Joint (Rr. Shaft; Frt.) ③		UJ331	U-Joint (Rr. Shaft; Frt.) ③		UJ331
<i>Brute Force Greaseable</i>		UJ232	<i>Brute Force Greaseable</i>		UJ232
<i>Brute Force Non Greaseable</i>		UJ231	<i>Brute Force Non Greaseable</i>		UJ231
(For Aluminum Drive Shaft)		UJ331C	(For Aluminum Drive Shaft)		UJ331C
Clamp Kit (Rr. Shaft; Frt.)		UJ492-10	Clamp Kit (Rr. Shaft; Frt.)		UJ492-10
U-Joint (Rr. Shaft; Rr.) ④		UJ331	U-Joint (Rr. Shaft; Rr.) ④		UJ331
<i>Brute Force Greaseable</i>		UJ232	<i>Brute Force Greaseable</i>		UJ232
<i>Brute Force Non Greaseable</i>		UJ231	<i>Brute Force Non Greaseable</i>		UJ231
(For Aluminum Drive Shaft)		UJ331C	(For Aluminum Drive Shaft)		UJ331C
Clamp Kit (Rr. Shaft; Rr.)		UJ492-10	Clamp Kit (Rr. Shaft; Rr.)		UJ492-10

(Continued)

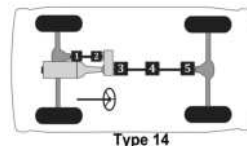
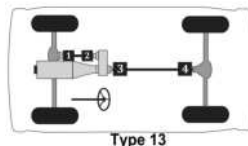

Passenger cars, light & medium trucks

Chevrolet/GMC Truck 1/2 ton -- (Cont.)

MFG./YEAR	MODEL & LOCATION	PART NO.	MFG./YEAR	MODEL & LOCATION	PART NO.
-----------	------------------	----------	-----------	------------------	----------

Drive Shaft (4 W/D) (Cont.)

U-Joint (Cont.)

1993-1992 K1500 w/ Ext. Cab & Long Bed Exc.

MT8 Man. Trans.: [Type 14]

U-Joint (Fr. Shaft; Frt.) [⊙]	UJ534G
Brute Force Greaseable	UJ235
Brute Force Non Greaseable	UJ234
Clamp Kit (Fr. Shaft; Frt.)	UJ530-10
U-Joint (Fr. Shaft; Rr.) [⊙]	UJ534G
Brute Force Greaseable	UJ235
Brute Force Non Greaseable	UJ234
Clamp Kit (Fr. Shaft; Rr.)	UJ530-10
U-Joint (Rr. Shaft; Frt.) [⊙]	UJ354
Brute Force Greaseable	UJ270
Brute Force Non Greaseable	UJ254
(For Aluminum Drive Shaft)	UJ354C
U-Joint (Rr. Shaft; Ctr.) [⊙]	UJ354
Brute Force Greaseable	UJ270
Brute Force Non Greaseable	UJ254
(For Aluminum Drive Shaft)	UJ354C
U-Joint (Rr. Shaft; Rr.) [⊙]	UJ355
Brute Force Greaseable	UJ290
(For Aluminum Drive Shaft)	UJ355C
Clamp Kit (Rr. Shaft; Rr.)	UJ530-10

1993-1992 K1500 w/ Ext. Cab & Long Bed w/o HD

Chassis: [Type 14]

U-Joint (Fr. Shaft; Frt.) [⊙]	UJ534G
Brute Force Greaseable	UJ235
Brute Force Non Greaseable	UJ234
Clamp Kit (Fr. Shaft; Frt.)	UJ530-10
U-Joint (Fr. Shaft; Rr.) [⊙]	UJ534G
Brute Force Greaseable	UJ235
Brute Force Non Greaseable	UJ234
Clamp Kit (Fr. Shaft; Rr.)	UJ530-10
U-Joint (Rr. Shaft; Frt.) [⊙]	UJ354
Brute Force Greaseable	UJ270
Brute Force Non Greaseable	UJ254
(For Aluminum Drive Shaft)	UJ354C
U-Joint (Rr. Shaft; Ctr.) [⊙]	UJ354
Brute Force Greaseable	UJ270
Brute Force Non Greaseable	UJ254
(For Aluminum Drive Shaft)	UJ354C
U-Joint (Rr. Shaft; Rr.) [⊙]	UJ355
Brute Force Greaseable	UJ290
(For Aluminum Drive Shaft)	UJ355C
Clamp Kit (Rr. Shaft; Rr.)	UJ530-10

Drive Shaft (4 W/D) (Cont.)

U-Joint (Cont.)

1991-1988 Suburban w/ Auto Trans.: [Type 26]

U-Joint (Fr. Shaft; Frt.) [⊙]	UJ369
Brute Force Greaseable	UJ280
Brute Force Non Greaseable	UJ269
(For Aluminum Drive Shaft)	UJ369C
Clamp Kit (Fr. Shaft; Frt.)	UJ360-10
U-Joint (Fr. Shaft; Rr.) [⊙]	[2] UJ534G
Brute Force Greaseable	UJ235
Brute Force Non Greaseable	UJ234
Clamp Kit (Fr. Shaft; Rr.)	UJ530-10
U-Joint (Rr. Shaft; Frt.) [⊙]	UJ534G
Brute Force Greaseable	UJ235
Brute Force Non Greaseable	UJ234
Clamp Kit (Rr. Shaft; Frt.)	UJ530-10
U-Joint (Rr. Shaft; Rr.) [⊙]	UJ534G
Brute Force Greaseable	UJ235
Brute Force Non Greaseable	UJ234
Clamp Kit (Rr. Shaft; Rr.)	UJ530-10
U-Joint (Wheel Joint) [⊙]	[2] UJ371
Brute Force Greaseable	UJ377
Brute Force Non Greaseable	UJ371
Ball Seat Repair Kit	UJ606
Flange Yoke	UJ626
H Yoke	UJ646

1991-1988 Suburban w/ Man. Trans.: [Type 26]

U-Joint (Fr. Shaft; Frt.) [⊙]	UJ369
Brute Force Greaseable	UJ280
Brute Force Non Greaseable	UJ269
(For Aluminum Drive Shaft)	UJ369C
Clamp Kit (Fr. Shaft; Frt.)	UJ360-10
U-Joint (Fr. Shaft; Rr.) [⊙]	[2] UJ534G
Brute Force Greaseable	UJ235
Brute Force Non Greaseable	UJ234
Clamp Kit (Fr. Shaft; Rr.)	UJ530-10
U-Joint (Rr. Shaft; Frt.) [⊙]	UJ331
Brute Force Greaseable	UJ232
Brute Force Non Greaseable	UJ231
(For Aluminum Drive Shaft)	UJ331C
Clamp Kit (Rr. Shaft; Frt.)	UJ492-10
U-Joint (Rr. Shaft; Rr.) [⊙]	UJ331
Brute Force Greaseable	UJ232
Brute Force Non Greaseable	UJ231
(For Aluminum Drive Shaft)	UJ331C
Clamp Kit (Rr. Shaft; Rr.)	UJ492-10
U-Joint (Wheel Joint) [⊙]	[2] UJ371
Brute Force Greaseable	UJ377
Brute Force Non Greaseable	UJ371
Ball Seat Repair Kit	UJ606
Flange Yoke	UJ626
H Yoke	UJ646

(Continued)

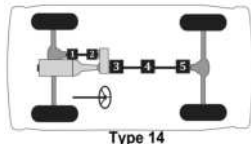

Type 14

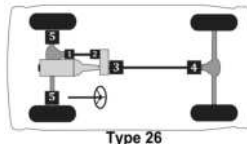

Type 26

Passenger cars, light & medium trucks

(Cont.) -- Chevrolet/GMC Truck 1/2 ton

MFG./YEAR	MODEL & LOCATION	PART NO.	MFG./YEAR	MODEL & LOCATION	PART NO.
Drive Shaft (4 W/D) (Cont.)			Drive Shaft (4 W/D) (Cont.)		
U-Joint (Cont.)			U-Joint (Cont.)		
1991-1988 K1500 w/ Reg. Cab & Auto. Trans.:			1991-1988 K1500 w/ Ext. Cab & Auto. Trans.:		
[Type 13]			[Type 14]		
U-Joint (Fr. Shaft; Fr.) ①		UJ534G	U-Joint (Fr. Shaft; Fr.) ①		UJ534G
<i>Brute Force Greaseable</i>		UJ235	<i>Brute Force Greaseable</i>		UJ235
<i>Brute Force Non Greaseable</i>		UJ234	<i>Brute Force Non Greaseable</i>		UJ234
Clamp Kit (Fr. Shaft; Fr.)		UJ530-10	Clamp Kit (Fr. Shaft; Fr.)		UJ530-10
U-Joint (Fr. Shaft; Rr.) ②		UJ534G	U-Joint (Fr. Shaft; Rr.) ②		UJ534G
<i>Brute Force Greaseable</i>		UJ235	<i>Brute Force Greaseable</i>		UJ235
<i>Brute Force Non Greaseable</i>		UJ234	<i>Brute Force Non Greaseable</i>		UJ234
Clamp Kit (Fr. Shaft; Rr.)		UJ530-10	Clamp Kit (Fr. Shaft; Rr.)		UJ530-10
U-Joint (Rr. Shaft; Fr.) ③		UJ534G	U-Joint (Rr. Shaft; Fr.) ③		UJ354
<i>Brute Force Greaseable</i>		UJ235	<i>Brute Force Greaseable</i>		UJ270
<i>Brute Force Non Greaseable</i>		UJ234	<i>Brute Force Non Greaseable</i>		UJ254
Clamp Kit (Rr. Shaft; Fr.)		UJ530-10	(For Aluminum Drive Shaft)		UJ354C
U-Joint (Rr. Shaft; Rr.) ④		UJ534G	U-Joint (Rr. Shaft; Ctr.) ④		UJ354
<i>Brute Force Greaseable</i>		UJ235	<i>Brute Force Greaseable</i>		UJ270
<i>Brute Force Non Greaseable</i>		UJ234	<i>Brute Force Non Greaseable</i>		UJ254
Clamp Kit (Rr. Shaft; Rr.)		UJ530-10	(For Aluminum Drive Shaft)		UJ354C
1991-1988 K1500 w/ Reg. Cab & Man. Trans.:			1991-1988 K1500 w/ Ext. Cab & Man. Trans.:		
[Type 13]			[Type 14]		
U-Joint (Fr. Shaft; Fr.) ①		UJ355	U-Joint (Fr. Shaft; Fr.) ①		UJ355
<i>Brute Force Greaseable</i>		UJ290	<i>Brute Force Greaseable</i>		UJ290
(For Aluminum Drive Shaft)		UJ355C	(For Aluminum Drive Shaft)		UJ355C
U-Joint (Fr. Shaft; Rr.) ②		UJ354	U-Joint (Fr. Shaft; Rr.) ②		UJ354
<i>Brute Force Greaseable</i>		UJ270	<i>Brute Force Greaseable</i>		UJ270
<i>Brute Force Non Greaseable</i>		UJ254	<i>Brute Force Non Greaseable</i>		UJ254
(For Aluminum Drive Shaft)		UJ354C	(For Aluminum Drive Shaft)		UJ354C
U-Joint (Rr. Shaft; Fr.) ③		UJ331	U-Joint (Rr. Shaft; Fr.) ③		UJ331
<i>Brute Force Greaseable</i>		UJ232	<i>Brute Force Greaseable</i>		UJ232
<i>Brute Force Non Greaseable</i>		UJ231	<i>Brute Force Non Greaseable</i>		UJ231
(For Aluminum Drive Shaft)		UJ331C	(For Aluminum Drive Shaft)		UJ331C
Clamp Kit (Rr. Shaft; Fr.)		UJ492-10	Clamp Kit (Rr. Shaft; Fr.)		UJ492-10
U-Joint (Rr. Shaft; Rr.) ④		UJ331	U-Joint (Rr. Shaft; Fr.) ④		UJ331
<i>Brute Force Greaseable</i>		UJ232	<i>Brute Force Greaseable</i>		UJ232
<i>Brute Force Non Greaseable</i>		UJ231	<i>Brute Force Non Greaseable</i>		UJ231
(For Aluminum Drive Shaft)		UJ331C	(For Aluminum Drive Shaft)		UJ331C
Clamp Kit (Rr. Shaft; Rr.)		UJ492-10	Clamp Kit (Rr. Shaft; Ctr.)		UJ492-10
			U-Joint (Rr. Shaft; Ctr.) ④		UJ331
			<i>Brute Force Greaseable</i>		UJ232
			<i>Brute Force Non Greaseable</i>		UJ231
			(For Aluminum Drive Shaft)		UJ331C
			Clamp Kit (Rr. Shaft; Ctr.)		UJ492-10
			U-Joint (Rr. Shaft; Rr.) ④		UJ331
			<i>Brute Force Greaseable</i>		UJ232
			<i>Brute Force Non Greaseable</i>		UJ231
			(For Aluminum Drive Shaft)		UJ331C
			Clamp Kit (Rr. Shaft; Rr.)		UJ492-10

(Continued)

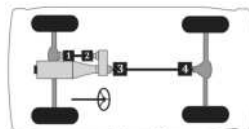

Type 13

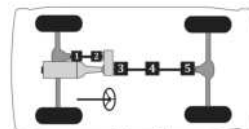

Type 14

Passenger cars, light & medium trucks

Chevrolet/GMC Truck 1/2 ton -- (Cont.)

MFG./YEAR	MODEL & LOCATION	PART NO.	MFG./YEAR	MODEL & LOCATION	PART NO.
-----------	------------------	----------	-----------	------------------	----------

Drive Shaft (4 W/D) (Cont.)

U-Joint (Cont.)

1991-1982 Blazer & Jimmy w/ 4 Spd. Man.

Trans.: [Type 26]

U-Joint (Fr. Shaft; Fr.) [⊙]	UJ369
Brute Force Greaseable	UJ280
Brute Force Non Greaseable	UJ269
(For Aluminum Drive Shaft)	UJ369C
Clamp Kit (Fr. Shaft; Fr.)	UJ360-10
U-Joint (Fr. Shaft; Rr.) [⊙]	[2] UJ534G
Brute Force Greaseable	UJ235
Brute Force Non Greaseable	UJ234
Clamp Kit (Fr. Shaft; Rr.)	UJ530-10
U-Joint (Rr. Shaft; Fr.) [⊙]	UJ331
Brute Force Greaseable	UJ232
Brute Force Non Greaseable	UJ231
(For Aluminum Drive Shaft)	UJ331C
Clamp Kit (Rr. Shaft; Fr.)	UJ492-10
U-Joint (Rr. Shaft; Rr.) [⊙]	UJ331
Brute Force Greaseable	UJ232
Brute Force Non Greaseable	UJ231
(For Aluminum Drive Shaft)	UJ331C
Clamp Kit (Rr. Shaft; Rr.)	UJ492-10
U-Joint (Wheel Joint) [⊙]	[2] UJ371
Brute Force Greaseable	UJ377
Brute Force Non Greaseable	UJ371
Ball Seat Repair Kit	UJ606
Flange Yoke	UJ626
H Yoke	UJ646

1991-1982 Blazer & Jimmy Exc. 4 Spd. Man.

Trans.: [Type 26]

U-Joint (Fr. Shaft; Fr.) [⊙]	UJ369
Brute Force Greaseable	UJ280
Brute Force Non Greaseable	UJ269
(For Aluminum Drive Shaft)	UJ369C
Clamp Kit (Fr. Shaft; Fr.)	UJ360-10
U-Joint (Fr. Shaft; Rr.) [⊙]	[2] UJ534G
Brute Force Greaseable	UJ235
Brute Force Non Greaseable	UJ234
Clamp Kit (Fr. Shaft; Rr.)	UJ530-10
U-Joint (Rr. Shaft; Fr.) [⊙]	UJ534G
Brute Force Greaseable	UJ235
Brute Force Non Greaseable	UJ234
Clamp Kit (Rr. Shaft; Fr.)	UJ530-10
U-Joint (Rr. Shaft; Rr.) [⊙]	UJ534G
Brute Force Greaseable	UJ235
Brute Force Non Greaseable	UJ234
Clamp Kit (Rr. Shaft; Rr.)	UJ530-10
U-Joint (Wheel Joint) [⊙]	[2] UJ371
Brute Force Greaseable	UJ377
Brute Force Non Greaseable	UJ371
Ball Seat Repair Kit	UJ606
Flange Yoke	UJ626
H Yoke	UJ646

Drive Shaft (4 W/D) (Cont.)

U-Joint (Cont.)

1987 V10 & V1500 w/ Inner Lock Rings:

[Type 26]

U-Joint (Fr. Shaft; Fr.) [⊙]	UJ369
Brute Force Greaseable	UJ280
Brute Force Non Greaseable	UJ269
(For Aluminum Drive Shaft)	UJ369C
Clamp Kit (Fr. Shaft; Fr.)	UJ360-10
U-Joint (Fr. Shaft; Rr.) [⊙]	[2] UJ534G
Brute Force Greaseable	UJ235
Brute Force Non Greaseable	UJ234
Clamp Kit (Fr. Shaft; Rr.)	UJ530-10
U-Joint (Rr. Shaft; Fr.) [⊙]	UJ534G
Brute Force Greaseable	UJ235
Brute Force Non Greaseable	UJ234
Clamp Kit (Rr. Shaft; Fr.)	UJ530-10
U-Joint (Wheel Joint) [⊙]	[2] UJ371
Brute Force Greaseable	UJ377
Brute Force Non Greaseable	UJ371
Ball Seat Repair Kit	UJ606

1987 V10 & V1500 w/ Outer Lock Rings:

[Type 26]

U-Joint (Fr. Shaft; Fr.) [⊙]	UJ369
Brute Force Greaseable	UJ280
Brute Force Non Greaseable	UJ269
(For Aluminum Drive Shaft)	UJ369C
Clamp Kit (Fr. Shaft; Fr.)	UJ360-10
U-Joint (Fr. Shaft; Rr.) [⊙]	[2] UJ534G
Brute Force Greaseable	UJ235
Brute Force Non Greaseable	UJ234
Clamp Kit (Fr. Shaft; Rr.)	UJ530-10
U-Joint (Rr. Shaft; Fr.) [⊙]	UJ371
Brute Force Greaseable	UJ377
Brute Force Non Greaseable	UJ371
U-Joint (Rr. Shaft; Rr.) [⊙]	UJ331
Brute Force Greaseable	UJ232
Brute Force Non Greaseable	UJ231
(For Aluminum Drive Shaft)	UJ331C
U-Joint (Wheel Joint) [⊙]	[2] UJ371
Brute Force Greaseable	UJ377
Brute Force Non Greaseable	UJ371
Ball Seat Repair Kit	UJ606

(Continued)

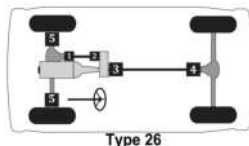

Passenger cars, light & medium trucks

(Cont.) -- Chevrolet/GMC Truck 1/2 ton

MFG./YEAR	MODEL & LOCATION	PART NO.	MFG./YEAR	MODEL & LOCATION	PART NO.
Drive Shaft (4 W/D) (Cont.)			Drive Shaft (4 W/D) (Cont.)		
U-Joint (Cont.)			U-Joint (Cont.)		
1986-1982 K10 & K1500 w/ Inner Lock Rings:			1981-1979 Blazer & Jimmy: [Type 26]		
	[Type 26]				
	U-Joint (Fr. Shaft; Fr.) ①	UJ369		U-Joint (Fr. Shaft; Fr.) ①	UJ369
	<i>Brute Force Greaseable</i>	UJ280		<i>Brute Force Greaseable</i>	UJ280
	<i>Brute Force Non Greaseable</i>	UJ269		<i>Brute Force Non Greaseable</i>	UJ269
	(For Aluminum Drive Shaft)	UJ369C		(For Aluminum Drive Shaft)	UJ369C
	Clamp Kit (Fr. Shaft; Fr.)	UJ360-10		Clamp Kit (Fr. Shaft; Fr.)	UJ360-10
	U-Joint (Fr. Shaft; Rr.) ②	[2] UJ534G		U-Joint (Fr. Shaft; Rr.) ②	[2] UJ534G
	<i>Brute Force Greaseable</i>	UJ235		<i>Brute Force Greaseable</i>	UJ235
	<i>Brute Force Non Greaseable</i>	UJ234		<i>Brute Force Non Greaseable</i>	UJ234
	Clamp Kit (Fr. Shaft; Rr.)	UJ530-10		Clamp Kit (Fr. Shaft; Rr.)	UJ530-10
	U-Joint (Rr. Shaft; Fr.) ③	UJ534G		U-Joint (Rr. Shaft; Fr.) ③	UJ369
	<i>Brute Force Greaseable</i>	UJ235		<i>Brute Force Greaseable</i>	UJ280
	<i>Brute Force Non Greaseable</i>	UJ234		<i>Brute Force Non Greaseable</i>	UJ269
	(For Aluminum Drive Shaft)	UJ369C		(For Aluminum Drive Shaft)	UJ369C
	Clamp Kit (Rr. Shaft; Fr.)	UJ360-10		Clamp Kit (Rr. Shaft; Fr.)	UJ360-10
	U-Joint (Rr. Shaft; Rr.) ④	UJ534G		U-Joint (Rr. Shaft; Rr.) ④	UJ369
	<i>Brute Force Greaseable</i>	UJ235		<i>Brute Force Greaseable</i>	UJ280
	<i>Brute Force Non Greaseable</i>	UJ234		<i>Brute Force Non Greaseable</i>	UJ269
	(For Aluminum Drive Shaft)	UJ369C		(For Aluminum Drive Shaft)	UJ369C
	Clamp Kit (Rr. Shaft; Rr.)	UJ530-10		Clamp Kit (Rr. Shaft; Rr.)	UJ360-10
	U-Joint (Wheel Joint) ⑤	[2] UJ371		U-Joint (Wheel Joint) ⑤	[2] UJ371
	<i>Brute Force Greaseable</i>	UJ377		<i>Brute Force Greaseable</i>	UJ377
	<i>Brute Force Non Greaseable</i>	UJ371		<i>Brute Force Non Greaseable</i>	UJ371
	Ball Seat Repair Kit	UJ606		Ball Seat Repair Kit	UJ606
	Flange Yoke	UJ626		Flange Yoke	UJ626
	H Yoke	UJ646		H Yoke	UJ646
1986-1982 K10 & K1500 w/ Outer Lock Rings:			1981-1979 K10 & K1500: [Type 26]		
	[Type 26]				
	U-Joint (Fr. Shaft; Fr.) ①	UJ369		U-Joint (Fr. Shaft; Fr.) ①	UJ369
	<i>Brute Force Greaseable</i>	UJ280		<i>Brute Force Greaseable</i>	UJ280
	<i>Brute Force Non Greaseable</i>	UJ269		<i>Brute Force Non Greaseable</i>	UJ269
	(For Aluminum Drive Shaft)	UJ369C		(For Aluminum Drive Shaft)	UJ369C
	Clamp Kit (Fr. Shaft; Fr.)	UJ360-10		Clamp Kit (Fr. Shaft; Fr.)	UJ360-10
	U-Joint (Fr. Shaft; Rr.) ②	[2] UJ534G		U-Joint (Fr. Shaft; Rr.) ②	[2] UJ534G
	<i>Brute Force Greaseable</i>	UJ235		<i>Brute Force Greaseable</i>	UJ235
	<i>Brute Force Non Greaseable</i>	UJ234		<i>Brute Force Non Greaseable</i>	UJ234
	Clamp Kit (Fr. Shaft; Rr.)	UJ530-10		Clamp Kit (Fr. Shaft; Rr.)	UJ530-10
	U-Joint (Rr. Shaft; Fr.) ③	UJ331		U-Joint (Rr. Shaft; Fr.) ③	UJ369
	<i>Brute Force Greaseable</i>	UJ232		<i>Brute Force Greaseable</i>	UJ280
	<i>Brute Force Non Greaseable</i>	UJ231		<i>Brute Force Non Greaseable</i>	UJ269
	(For Aluminum Drive Shaft)	UJ331C		(For Aluminum Drive Shaft)	UJ369C
	U-Joint (Rr. Shaft; Rr.) ④	UJ331		U-Joint (Rr. Shaft; Rr.) ④	UJ369
	<i>Brute Force Greaseable</i>	UJ232		<i>Brute Force Greaseable</i>	UJ280
	<i>Brute Force Non Greaseable</i>	UJ231		<i>Brute Force Non Greaseable</i>	UJ269
	(For Aluminum Drive Shaft)	UJ331C		(For Aluminum Drive Shaft)	UJ369C
	U-Joint (Wheel Joint) ⑤	[2] UJ371		U-Joint (Wheel Joint) ⑤	[2] UJ371
	<i>Brute Force Greaseable</i>	UJ377		<i>Brute Force Greaseable</i>	UJ377
	<i>Brute Force Non Greaseable</i>	UJ371		<i>Brute Force Non Greaseable</i>	UJ371
	Ball Seat Repair Kit	UJ606		Ball Seat Repair Kit	UJ606
	Flange Yoke	UJ626		Flange Yoke	UJ626
	H Yoke	UJ646		H Yoke	UJ646

(Continued)

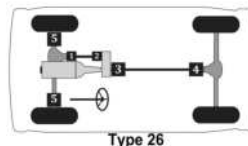

Passenger cars, light & medium trucks

Chevrolet/GMC Truck 1/2 ton -- (Cont.)

MFG./YEAR	MODEL & LOCATION	PART NO.	MFG./YEAR	MODEL & LOCATION	PART NO.
-----------	------------------	----------	-----------	------------------	----------

Drive Shaft (4 W/D) (Cont.)

U-Joint (Cont.)

1978	K10 & K15 w/ Inner Lock Rings & 2	
	Joint Shaft: [Type 26]	
U-Joint (Fr. Shaft; Fr.) Ⓚ		UJ369
<i>Brute Force Greaseable</i>		UJ280
<i>Brute Force Non Greaseable</i>		UJ269
(For Aluminum Drive Shaft)		UJ369C
U-Bolt Kit (Fr. Shaft; Fr.)		UJ329-10
U-Joint (Fr. Shaft; Rr.) Ⓚ	[2]	UJ534G
<i>Brute Force Greaseable</i>		UJ235
<i>Brute Force Non Greaseable</i>		UJ234
(For Aluminum Drive Shaft)		UJ369C
U-Bolt Kit (Rr. Shaft; Fr.)		UJ329-10
U-Joint (Rr. Shaft; Fr.) Ⓚ		UJ369
<i>Brute Force Greaseable</i>		UJ280
<i>Brute Force Non Greaseable</i>		UJ269
(For Aluminum Drive Shaft)		UJ369C
U-Bolt Kit (Rr. Shaft; Rr.)		UJ329-10
U-Joint (Rr. Shaft; Rr.) Ⓚ		UJ369
<i>Brute Force Greaseable</i>		UJ280
<i>Brute Force Non Greaseable</i>		UJ269
(For Aluminum Drive Shaft)		UJ369C
U-Bolt Kit (Rr. Shaft; Rr.)		UJ329-10
U-Joint (Wheel Joint) Ⓚ	[2]	UJ371
<i>Brute Force Greaseable</i>		UJ377
<i>Brute Force Non Greaseable</i>		UJ371
Ball Seat Repair Kit		UJ606
Flange Yoke		UJ626
H Yoke		UJ646

Drive Shaft (4 W/D) (Cont.)

U-Joint (Cont.)

1978	K10 & K15 w/ Inner Lock Rings & 3	
	Joint Shaft: [Type 27]	
U-Joint (Fr. Shaft; Fr.) Ⓚ		UJ369
<i>Brute Force Greaseable</i>		UJ280
<i>Brute Force Non Greaseable</i>		UJ269
(For Aluminum Drive Shaft)		UJ369C
U-Bolt Kit (Fr. Shaft; Fr.)		UJ329-10
U-Joint (Fr. Shaft; Rr.) Ⓚ	[2]	UJ534G
<i>Brute Force Greaseable</i>		UJ235
<i>Brute Force Non Greaseable</i>		UJ234
(For Aluminum Drive Shaft)		UJ369C
U-Bolt Kit (Rr. Shaft; Fr.)		UJ329-10
U-Joint (Rr. Shaft; Fr.) Ⓚ		UJ369
<i>Brute Force Greaseable</i>		UJ280
<i>Brute Force Non Greaseable</i>		UJ269
(For Aluminum Drive Shaft)		UJ369C
U-Bolt Kit (Rr. Shaft; Rr.)		UJ329-10
U-Joint (Rr. Shaft; Ctr.) Ⓚ		UJ331
<i>Brute Force Greaseable</i>		UJ232
<i>Brute Force Non Greaseable</i>		UJ231
(For Aluminum Drive Shaft)		UJ331C
U-Joint (Rr. Shaft; Rr.) Ⓚ		UJ331
<i>Brute Force Greaseable</i>		UJ232
<i>Brute Force Non Greaseable</i>		UJ231
(For Aluminum Drive Shaft)		UJ331C
U-Joint (Wheel Joint) Ⓚ	[2]	UJ371
<i>Brute Force Greaseable</i>		UJ377
<i>Brute Force Non Greaseable</i>		UJ371
Ball Seat Repair Kit		UJ606
Flange Yoke		UJ626
H Yoke		UJ646

(Continued)

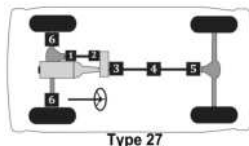
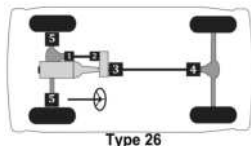

Passenger cars, light & medium trucks

(Cont.) -- Chevrolet/GMC Truck 1/2 ton

MFG./YEAR	MODEL & LOCATION	PART NO.	MFG./YEAR	MODEL & LOCATION	PART NO.
Drive Shaft (4 W/D) (Cont.)			Drive Shaft (4 W/D) (Cont.)		
U-Joint (Cont.)			U-Joint (Cont.)		
1978	K10 & K15 w/ Outer Lock Rings & 2 Joint Shaft: [Type 26]		1978	K10 & K15 w/ Outer Lock Rings & 3 Joint Shaft: [Type 27]	
	U-Joint (Frt. Shaft; Frt.) ①	UJ369		U-Joint (Frt. Shaft; Frt.) ①	UJ369
	<i>Brute Force Greaseable</i>	UJ280		<i>Brute Force Greaseable</i>	UJ280
	<i>Brute Force Non Greaseable</i>	UJ269		<i>Brute Force Non Greaseable</i>	UJ269
	(For Aluminum Drive Shaft)	UJ369C		(For Aluminum Drive Shaft)	UJ369C
	U-Bolt Kit (Frt. Shaft; Frt.)	UJ329-10		U-Bolt Kit (Frt. Shaft; Frt.)	UJ329-10
	U-Joint (Frt. Shaft; Rr.) ②	[2] UJ379		U-Joint (Frt. Shaft; Rr.) ②	[2] UJ379
	<i>Brute Force Greaseable</i>	UJ280		<i>Brute Force Greaseable</i>	UJ280
	<i>Brute Force Non Greaseable</i>	UJ269		<i>Brute Force Non Greaseable</i>	UJ269
	U-Joint (Rr. Shaft; Frt.) ③	UJ369		U-Joint (Rr. Shaft; Frt.) ③	UJ369
	<i>Brute Force Greaseable</i>	UJ280		<i>Brute Force Greaseable</i>	UJ280
	<i>Brute Force Non Greaseable</i>	UJ269		<i>Brute Force Non Greaseable</i>	UJ269
	(For Aluminum Drive Shaft)	UJ369C		(For Aluminum Drive Shaft)	UJ369C
	U-Bolt Kit (Rr. Shaft; Frt.)	UJ329-10		U-Bolt Kit (Rr. Shaft; Frt.)	UJ329-10
	U-Joint (Rr. Shaft; Rr.) ④	UJ369		U-Joint (Rr. Shaft; Ctr.) ④	UJ331
	<i>Brute Force Greaseable</i>	UJ280		<i>Brute Force Greaseable</i>	UJ232
	<i>Brute Force Non Greaseable</i>	UJ269		<i>Brute Force Non Greaseable</i>	UJ231
	(For Aluminum Drive Shaft)	UJ369C		(For Aluminum Drive Shaft)	UJ331C
	U-Bolt Kit (Rr. Shaft; Rr.)	UJ329-10		U-Joint (Rr. Shaft; Rr.) ⑤	UJ331
	U-Joint (Wheel Joint) ⑥	[2] UJ371		<i>Brute Force Greaseable</i>	UJ232
	<i>Brute Force Greaseable</i>	UJ377		<i>Brute Force Non Greaseable</i>	UJ231
	<i>Brute Force Non Greaseable</i>	UJ371		(For Aluminum Drive Shaft)	UJ331C
	Centering Yoke	UJ607		U-Joint (Wheel Joint) ⑥	[2] UJ371
	H Yoke	UJ647		<i>Brute Force Greaseable</i>	UJ377
				<i>Brute Force Non Greaseable</i>	UJ371
				Centering Yoke	UJ607
				H Yoke	UJ647

(Continued)

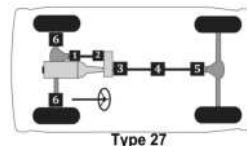
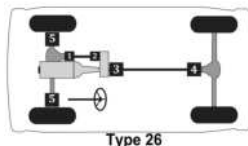

Passenger cars, light & medium trucks

Chevrolet/GMC Truck 1/2 ton -- (Cont.)

MFG./YEAR	MODEL & LOCATION	PART NO.	MFG./YEAR	MODEL & LOCATION	PART NO.
Drive Shaft (4 W/D) (Cont.)			Drive Shaft (4 W/D) (Cont.)		
U-Joint (Cont.)			U-Joint (Cont.)		
1978-1975 Blazer & Jimmy w/ Inner Lock Rings:			1977-1973 K10 & K15: [Type 26]		
[Type 26]			U-Joint (Fr. Shaft; Frt.) UJ369		
U-Joint (Fr. Shaft; Frt.) UJ369			<i>Brute Force Greaseable</i> UJ280		
<i>Brute Force Greaseable</i> UJ280			<i>Brute Force Non Greaseable</i> UJ269		
<i>Brute Force Non Greaseable</i> UJ269			(For Aluminum Drive Shaft) UJ369C		
(For Aluminum Drive Shaft) UJ369C			U-Bolt Kit (Fr. Shaft; Frt.) UJ329-10		
U-Bolt Kit (Fr. Shaft; Frt.) UJ329-10			U-Joint (Fr. Shaft; Rr.) [2] UJ534G		
U-Joint (Fr. Shaft; Rr.) [2] UJ534G			<i>Brute Force Greaseable</i> UJ235		
<i>Brute Force Greaseable</i> UJ235			<i>Brute Force Non Greaseable</i> UJ234		
<i>Brute Force Non Greaseable</i> UJ234			U-Joint (Rr. Shaft; Frt.) UJ369		
U-Joint (Rr. Shaft; Frt.) UJ369			<i>Brute Force Greaseable</i> UJ280		
<i>Brute Force Greaseable</i> UJ280			<i>Brute Force Non Greaseable</i> UJ269		
<i>Brute Force Non Greaseable</i> UJ269			(For Aluminum Drive Shaft) UJ369C		
(For Aluminum Drive Shaft) UJ369C			U-Bolt Kit (Rr. Shaft; Frt.) UJ329-10		
U-Bolt Kit (Rr. Shaft; Frt.) UJ329-10			U-Joint (Rr. Shaft; Rr.) UJ369		
U-Joint (Rr. Shaft; Rr.) UJ369			<i>Brute Force Greaseable</i> UJ280		
<i>Brute Force Greaseable</i> UJ280			<i>Brute Force Non Greaseable</i> UJ269		
<i>Brute Force Non Greaseable</i> UJ269			(For Aluminum Drive Shaft) UJ369C		
(For Aluminum Drive Shaft) UJ369C			U-Bolt Kit (Rr. Shaft; Rr.) UJ329-10		
U-Bolt Kit (Rr. Shaft; Rr.) UJ329-10			U-Joint (Wheel Joint) [2] UJ371		
U-Joint (Wheel Joint) [2] UJ371			<i>Brute Force Greaseable</i> UJ377		
<i>Brute Force Greaseable</i> UJ377			<i>Brute Force Non Greaseable</i> UJ371		
<i>Brute Force Non Greaseable</i> UJ371			Ball Seat Repair Kit UJ606		
Ball Seat Repair Kit UJ606			Flange Yoke UJ626		
Flange Yoke UJ626			H Yoke UJ646		
H Yoke UJ646			1974-1972 Blazer & Jimmy w/ Outer Lock Rings:		
1978-1975 Blazer & Jimmy w/ Outer Lock Rings:			[Type 26]		
[Type 26]			U-Joint (Fr. Shaft; Frt.) UJ369		
U-Joint (Fr. Shaft; Frt.) UJ369			<i>Brute Force Greaseable</i> UJ280		
<i>Brute Force Greaseable</i> UJ280			<i>Brute Force Non Greaseable</i> UJ269		
<i>Brute Force Non Greaseable</i> UJ269			(For Aluminum Drive Shaft) UJ369C		
(For Aluminum Drive Shaft) UJ369C			U-Bolt Kit (Fr. Shaft; Frt.) UJ329-10		
U-Bolt Kit (Fr. Shaft; Frt.) UJ329-10			U-Joint (Fr. Shaft; Rr.) [2] UJ379		
U-Joint (Fr. Shaft; Rr.) [2] UJ379			<i>Brute Force Greaseable</i> UJ280		
<i>Brute Force Greaseable</i> UJ280			<i>Brute Force Non Greaseable</i> UJ269		
<i>Brute Force Non Greaseable</i> UJ269			U-Joint (Rr. Shaft; Frt.) UJ369		
U-Joint (Rr. Shaft; Frt.) UJ369			<i>Brute Force Greaseable</i> UJ280		
<i>Brute Force Greaseable</i> UJ280			<i>Brute Force Non Greaseable</i> UJ269		
<i>Brute Force Non Greaseable</i> UJ269			(For Aluminum Drive Shaft) UJ369C		
(For Aluminum Drive Shaft) UJ369C			U-Bolt Kit (Rr. Shaft; Frt.) UJ329-10		
U-Bolt Kit (Rr. Shaft; Frt.) UJ329-10			U-Joint (Rr. Shaft; Rr.) UJ369		
U-Joint (Rr. Shaft; Rr.) UJ369			<i>Brute Force Greaseable</i> UJ280		
<i>Brute Force Greaseable</i> UJ280			<i>Brute Force Non Greaseable</i> UJ269		
<i>Brute Force Non Greaseable</i> UJ269			(For Aluminum Drive Shaft) UJ369C		
(For Aluminum Drive Shaft) UJ369C			U-Bolt Kit (Rr. Shaft; Rr.) UJ329-10		
U-Bolt Kit (Rr. Shaft; Rr.) UJ329-10			U-Joint (Wheel Joint) [2] UJ365		
U-Joint (Wheel Joint) [2] UJ365			<i>Brute Force Greaseable</i> UJ378		
<i>Brute Force Greaseable</i> UJ378			<i>Brute Force Non Greaseable</i> UJ365		
<i>Brute Force Non Greaseable</i> UJ365			Ball Seat Repair Kit UJ606		
Ball Seat Repair Kit UJ606			Centering Yoke UJ607		
Centering Yoke UJ607			H Yoke UJ647		
H Yoke UJ647					

(Continued)

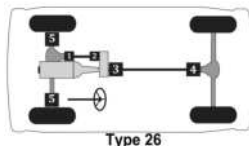

Passenger cars, light & medium trucks

(Cont.) -- Chevrolet/GMC Truck 1/2 ton

MFG./YEAR	MODEL & LOCATION	PART NO.	MFG./YEAR	MODEL & LOCATION	PART NO.
Drive Shaft (4 W/D) (Cont.)			Drive Shaft (4 W/D) (Cont.)		
U-Joint (Cont.)			U-Joint (Cont.)		
1974-1972 Blazer & Jimmy w/ Inner Lock Rings:			1971-1970 K10 & K15: [Type 26]		
	[Type 26]				
	U-Joint (Fr. Shaft; Fr.) ①	UJ369		U-Joint (Fr. Shaft; Fr.) ①	UJ369
	<i>Brute Force Greaseable</i>	UJ280		<i>Brute Force Greaseable</i>	UJ280
	<i>Brute Force Non Greaseable</i>	UJ269		<i>Brute Force Non Greaseable</i>	UJ269
	(For Aluminum Drive Shaft)	UJ369C		(For Aluminum Drive Shaft)	UJ369C
	U-Bolt Kit (Fr. Shaft; Fr.)	UJ329-10		U-Bolt Kit (Fr. Shaft; Fr.)	UJ329-10
	U-Joint (Fr. Shaft; Rr.) ②	[2] UJ534G		U-Joint (Fr. Shaft; Rr.) ②	[2] UJ379
	<i>Brute Force Greaseable</i>	UJ235		<i>Brute Force Greaseable</i>	UJ280
	<i>Brute Force Non Greaseable</i>	UJ234		<i>Brute Force Non Greaseable</i>	UJ269
	U-Joint (Rr. Shaft; Fr.) ③	UJ369		U-Joint (Rr. Shaft; Fr.) ③	UJ369
	<i>Brute Force Greaseable</i>	UJ280		<i>Brute Force Greaseable</i>	UJ280
	<i>Brute Force Non Greaseable</i>	UJ269		<i>Brute Force Non Greaseable</i>	UJ269
	(For Aluminum Drive Shaft)	UJ369C		(For Aluminum Drive Shaft)	UJ369C
	U-Bolt Kit (Rr. Shaft; Fr.)	UJ329-10		U-Bolt Kit (Rr. Shaft; Fr.)	UJ329-10
	U-Joint (Rr. Shaft; Rr.) ④	UJ369		U-Joint (Rr. Shaft; Rr.) ④	UJ369
	<i>Brute Force Greaseable</i>	UJ280		<i>Brute Force Greaseable</i>	UJ280
	<i>Brute Force Non Greaseable</i>	UJ269		<i>Brute Force Non Greaseable</i>	UJ269
	(For Aluminum Drive Shaft)	UJ369C		(For Aluminum Drive Shaft)	UJ369C
	U-Bolt Kit (Rr. Shaft; Rr.)	UJ329-10		U-Bolt Kit (Rr. Shaft; Rr.)	UJ329-10
	U-Joint (Wheel Joint) ⑤	[2] UJ365		U-Joint (Wheel Joint) ⑤	[2] UJ365
	<i>Brute Force Greaseable</i>	UJ378		<i>Brute Force Greaseable</i>	UJ378
	<i>Brute Force Non Greaseable</i>	UJ365		<i>Brute Force Non Greaseable</i>	UJ365
	Ball Seat Repair Kit	UJ606		Centering Yoke	UJ607
	Flange Yoke	UJ626		H Yoke	UJ647
	H Yoke	UJ646			
	1972 K10 & K15: [Type 26]			1971-1969 Blazer & Jimmy: [Type 26]	
	U-Joint (Fr. Shaft; Fr.) ①	UJ369		U-Joint (Fr. Shaft; Fr.) ①	UJ369
	<i>Brute Force Greaseable</i>	UJ280		<i>Brute Force Greaseable</i>	UJ280
	<i>Brute Force Non Greaseable</i>	UJ269		<i>Brute Force Non Greaseable</i>	UJ269
	(For Aluminum Drive Shaft)	UJ369C		(For Aluminum Drive Shaft)	UJ369C
	U-Bolt Kit (Fr. Shaft; Fr.)	UJ329-10		U-Bolt Kit (Fr. Shaft; Fr.)	UJ329-10
	U-Joint (Fr. Shaft; Rr.) ②	[2] UJ379		U-Joint (Fr. Shaft; Rr.) ②	[2] UJ379
	<i>Brute Force Greaseable</i>	UJ280		<i>Brute Force Greaseable</i>	UJ280
	<i>Brute Force Non Greaseable</i>	UJ269		<i>Brute Force Non Greaseable</i>	UJ269
	U-Joint (Rr. Shaft; Fr.) ③	UJ369		U-Joint (Rr. Shaft; Fr.) ③	UJ369
	<i>Brute Force Greaseable</i>	UJ280		<i>Brute Force Greaseable</i>	UJ280
	<i>Brute Force Non Greaseable</i>	UJ269		<i>Brute Force Non Greaseable</i>	UJ269
	(For Aluminum Drive Shaft)	UJ369C		(For Aluminum Drive Shaft)	UJ369C
	U-Bolt Kit (Rr. Shaft; Fr.)	UJ329-10		U-Bolt Kit (Rr. Shaft; Fr.)	UJ329-10
	U-Joint (Rr. Shaft; Rr.) ④	UJ369		U-Joint (Rr. Shaft; Rr.) ④	UJ369
	<i>Brute Force Greaseable</i>	UJ280		<i>Brute Force Greaseable</i>	UJ280
	<i>Brute Force Non Greaseable</i>	UJ269		<i>Brute Force Non Greaseable</i>	UJ269
	(For Aluminum Drive Shaft)	UJ369C		(For Aluminum Drive Shaft)	UJ369C
	U-Bolt Kit (Rr. Shaft; Rr.)	UJ329-10		U-Bolt Kit (Rr. Shaft; Rr.)	UJ329-10
	U-Joint (Wheel Joint) ⑤	[2] UJ371		U-Joint (Wheel Joint) ⑤	UJ365
	<i>Brute Force Greaseable</i>	UJ377		<i>Brute Force Greaseable</i>	UJ378
	<i>Brute Force Non Greaseable</i>	UJ371		<i>Brute Force Non Greaseable</i>	UJ365
	Centering Yoke	UJ607		Centering Yoke	UJ607
	H Yoke	UJ647		H Yoke	UJ647

(Continued)

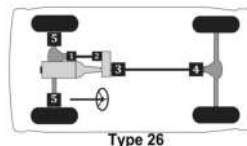

Passenger cars, light & medium trucks

Chevrolet/GMC Truck 1/2 ton -- (Cont.)

MFG./YEAR	MODEL & LOCATION	PART NO.	MFG./YEAR	MODEL & LOCATION	PART NO.
-----------	------------------	----------	-----------	------------------	----------

Drive Shaft (4 W/D) (Cont.)

U-Joint (Cont.)

1969-1967 K10 & K15: [Type 26]

U-Joint (Fr. Shaft; Frt.) [⊙]	UJ369
Brute Force Greaseable	UJ280
Brute Force Non Greaseable	UJ269
(For Aluminum Drive Shaft)	UJ369C
U-Bolt Kit (Fr. Shaft; Frt.)	UJ329-10
U-Joint (Fr. Shaft; Rr.) [⊙]	[2] UJ379
Brute Force Greaseable	UJ280
Brute Force Non Greaseable	UJ269
U-Joint (Rr. Shaft; Frt.) [⊙]	UJ369
Brute Force Greaseable	UJ280
Brute Force Non Greaseable	UJ269
(For Aluminum Drive Shaft)	UJ369C
U-Bolt Kit (Rr. Shaft; Frt.)	UJ329-10
U-Joint (Rr. Shaft; Rr.) [⊙]	UJ369
Brute Force Greaseable	UJ280
Brute Force Non Greaseable	UJ269
(For Aluminum Drive Shaft)	UJ369C
U-Bolt Kit (Rr. Shaft; Rr.)	UJ329-10
U-Joint (Wheel Joint) [⊙]	[2] UJ365
Brute Force Greaseable	UJ378
Brute Force Non Greaseable	UJ365
Centering Yoke	UJ607
Weld Yoke	UJ633
H Yoke	UJ647

Drive Shaft (AWD)

U-Joint

2013-2009 Yukon Denali: [Type 13]

U-Joint (Fr. Shaft; Frt.) [⊙]	UJ534G
Brute Force Greaseable	UJ235
Brute Force Non Greaseable	UJ234
Clamp Kit (Fr. Shaft; Frt.)	UJ530-10
U-Joint (Fr. Shaft; Rr.) [⊙]	UJ534G
Brute Force Greaseable	UJ235
Brute Force Non Greaseable	UJ234
Clamp Kit (Fr. Shaft; Rr.)	UJ530-10
U-Joint (Rr. Shaft; Frt.) [⊙]	UJ331A
Brute Force Greaseable	UJ232A
U-Joint (Rr. Shaft; Rr.) [⊙]	UJ331A
Brute Force Greaseable	UJ232A

Drive Shaft (AWD) (Cont.)

U-Joint (Cont.)

2008-2001 Yukon Denali: [Type 13]

U-Joint (Fr. Shaft; Frt.) [⊙]	UJ534G
Brute Force Greaseable	UJ235
Brute Force Non Greaseable	UJ234
Clamp Kit (Fr. Shaft; Frt.)	UJ530-10
U-Joint (Fr. Shaft; Rr.) [⊙]	UJ534G
Brute Force Greaseable	UJ235
Brute Force Non Greaseable	UJ234
Clamp Kit (Fr. Shaft; Rr.)	UJ530-10
U-Joint (Rr. Shaft; Frt.) [⊙]	UJ534G
Brute Force Greaseable	UJ235
Brute Force Non Greaseable	UJ234
Clamp Kit (Rr. Shaft; Frt.)	UJ530-10
U-Joint (Rr. Shaft; Rr.) [⊙]	UJ534G
Brute Force Greaseable	UJ235
Brute Force Non Greaseable	UJ234
Clamp Kit (Rr. Shaft; Rr.)	UJ530-10

2005-2003 Silverado SS: [Type 13]

U-Joint (Fr. Shaft; Frt.) [⊙]	UJ534G
Brute Force Greaseable	UJ235
Brute Force Non Greaseable	UJ234
Clamp Kit (Fr. Shaft; Frt.)	UJ530-10
U-Joint (Fr. Shaft; Rr.) [⊙]	UJ534G
Brute Force Greaseable	UJ235
Brute Force Non Greaseable	UJ234
Clamp Kit (Fr. Shaft; Rr.)	UJ530-10
U-Joint (Rr. Shaft; Frt.) [⊙]	UJ331
Brute Force Greaseable	UJ232
Brute Force Non Greaseable	UJ231
(For Aluminum Drive Shaft)	UJ331C
U-Joint (Rr. Shaft; Rr.) [⊙]	UJ331
Brute Force Greaseable	UJ232
Brute Force Non Greaseable	UJ231
(For Aluminum Drive Shaft)	UJ331C

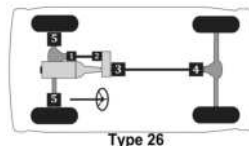
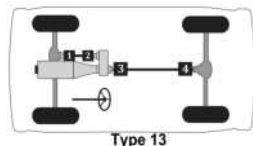

SKF

MFG./YEAR	MODEL & LOCATION	PART NO.	MFG./YEAR	MODEL & LOCATION	PART NO.
-----------	------------------	----------	-----------	------------------	----------

Drive Shaft (2 W/D)

U-Joint

2020-2008 Silverado & Sierra w/ Diesel Eng.:

[Type 2]

U-Joint (Front)⓪	UJ330A
Brute Force Greaseable	UJ295A
Clamp Kit (Front)	UJ492-10
U-Joint (Center)⓪	UJ351A
Brute Force Non Greaseable	UJ351ABF
U-Joint (Rear)⓪	UJ351A
Brute Force Non Greaseable	UJ351ABF

2019-2008 Silverado & Sierra w/ Gas Eng.:

[Type 2]

U-Joint (Front)⓪	UJ330A
Brute Force Greaseable	UJ295A
Clamp Kit (Front)	UJ492-10
U-Joint (Center)⓪	UJ330A
Brute Force Greaseable	UJ295A
Clamp Kit (Center)	UJ492-10
U-Joint (Rear)⓪	UJ351A
Brute Force Non Greaseable	UJ351ABF

2013-2008 Suburban & Yukon XL: [Type 1]

U-Joint (Front)⓪	UJ330A
Brute Force Greaseable	UJ295A
Clamp Kit (Front)	UJ492-10
U-Joint (Rear)⓪	UJ330A
Brute Force Greaseable	UJ295A
Clamp Kit (Rear)	UJ492-10

2007 Suburban & Yukon XL: [Type 1]

U-Joint (Front)⓪	UJ331A
Brute Force Greaseable	UJ232A
Clamp Kit (Front)	UJ492-10
U-Joint (Rear)⓪	UJ331A
Brute Force Greaseable	UJ232A
Clamp Kit (Rear)	UJ492-10

2007 Silverado & Sierra w/ Diesel Eng. Exc.

Classic: [Type 2]

U-Joint (Front)⓪	UJ330A
Brute Force Greaseable	UJ295A
Clamp Kit (Front)	UJ492-10
U-Joint (Center)⓪	UJ351A
Brute Force Non Greaseable	UJ351ABF
U-Joint (Rear)⓪	UJ351A
Brute Force Non Greaseable	UJ351ABF

2007 Silverado & Sierra w/ Gas Eng. Exc.

Classic: [Type 2]

U-Joint (Front)⓪	UJ330A
Brute Force Greaseable	UJ295A
Clamp Kit (Front)	UJ492-10
U-Joint (Center)⓪	UJ330A
Brute Force Greaseable	UJ295A
Clamp Kit (Front)	UJ492-10
U-Joint (Rear)⓪	UJ351A
Brute Force Non Greaseable	UJ351ABF

Drive Shaft (2 W/D) (Cont.)

U-Joint (Cont.)

2007 Silverado & Sierra Classic w/ 6.0L

Eng., Ext. Cab & Long Bed: [Type 2]

U-Joint (Front)⓪	UJ330A
Brute Force Greaseable	UJ295A
Clamp Kit (Front)	UJ492-10
U-Joint (Center)⓪	UJ330A
Brute Force Greaseable	UJ295A
Clamp Kit (Center)	UJ492-10
U-Joint (Rear)⓪	UJ330A
Brute Force Greaseable	UJ295A
Clamp Kit (Rear)	UJ492-10

2007 Silverado & Sierra Classic w/ 6.0L

Eng. Exc. Ext. Cab & Long Bed:

[Type 2]

U-Joint (Front)⓪	UJ330
Brute Force Greaseable	UJ295
(For Aluminum Drive Shaft)	UJ330C
Clamp Kit (Front)	UJ492-10
U-Joint (Center)⓪	UJ330
Brute Force Greaseable	UJ295
(For Aluminum Drive Shaft)	UJ330C
Clamp Kit (Center)	UJ492-10
U-Joint (Rear)⓪	UJ330
Brute Force Greaseable	UJ295
(For Aluminum Drive Shaft)	UJ330C
Clamp Kit (Rear)	UJ492-10

2007 Silverado & Sierra Classic w/ Auto.

Trans., 6.6L & 8.1L Eng.s.: [Type 2]

U-Joint (Front)⓪	UJ330
Brute Force Greaseable	UJ295
(For Aluminum Drive Shaft)	UJ330C
Clamp Kit (Front)	UJ492-10
U-Joint (Center)⓪	UJ330
Brute Force Greaseable	UJ295
(For Aluminum Drive Shaft)	UJ330C
Clamp Kit (Center)	UJ492-10
U-Joint (Rear)⓪	UJ330
Brute Force Greaseable	UJ295
(For Aluminum Drive Shaft)	UJ330C
Clamp Kit (Rear)	UJ492-10

2007 Silverado & Sierra Classic w/ Man.

Trans., 6.6L & 8.1L Eng.s.: [Type 2]

U-Joint (Front)⓪	UJ351
(For Aluminum Drive Shaft)	UJ351C
Brute Force Non Greaseable	UJ351BF
U-Joint (Center)⓪	UJ351
(For Aluminum Drive Shaft)	UJ351C
Brute Force Non Greaseable	UJ351BF
U-Joint (Rear)⓪	UJ351
(For Aluminum Drive Shaft)	UJ351C
Brute Force Non Greaseable	UJ351BF

(Continued)

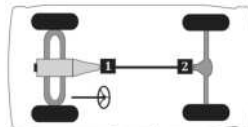

Type 1

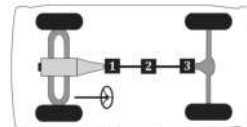

Type 2

Passenger cars, light & medium trucks

Chevrolet/GMC Truck 3/4 ton -- (Cont.)

MFG./YEAR	MODEL & LOCATION	PART NO.	MFG./YEAR	MODEL & LOCATION	PART NO.
-----------	------------------	----------	-----------	------------------	----------

Drive Shaft (2 W/D) (Cont.)

U-Joint (Cont.)

2006-2005 Silverado & Sierra w/ 6.0L Eng., Ext.

Cab & Long Bed: [Type 2]

U-Joint (Front)Ⓛ	UJ330A
Brute Force Greaseable	UJ295A
Clamp Kit (Front)	UJ492-10
U-Joint (Center)Ⓢ	UJ330A
Brute Force Greaseable	UJ295A
Clamp Kit (Center)	UJ492-10
U-Joint (Rear)Ⓢ	UJ330A
Brute Force Greaseable	UJ295A
Clamp Kit (Rear)	UJ492-10

2006-2005 Silverado & Sierra w/ 6.0L Eng. Exc.

Ext. Cab & Long Bed: [Type 2]

U-Joint (Front)Ⓛ	UJ330
Brute Force Greaseable	UJ295
(For Aluminum Drive Shaft)	UJ330C
Clamp Kit (Front)	UJ492-10
U-Joint (Center)Ⓢ	UJ330
Brute Force Greaseable	UJ295
(For Aluminum Drive Shaft)	UJ330C
Clamp Kit (Center)	UJ492-10
U-Joint (Rear)Ⓢ	UJ330
Brute Force Greaseable	UJ295
(For Aluminum Drive Shaft)	UJ330C
Clamp Kit (Rear)	UJ492-10

2006-2005 Silverado & Sierra w/ Auto. Trans.,

6.6L & 8.1L Eng.s.: [Type 2]

U-Joint (Front)Ⓛ	UJ330
Brute Force Greaseable	UJ295
(For Aluminum Drive Shaft)	UJ330C
Clamp Kit (Front)	UJ492-10
U-Joint (Center)Ⓢ	UJ330
Brute Force Greaseable	UJ295
(For Aluminum Drive Shaft)	UJ330C
Clamp Kit (Center)	UJ492-10
U-Joint (Rear)Ⓢ	UJ330
Brute Force Greaseable	UJ295
(For Aluminum Drive Shaft)	UJ330C
Clamp Kit (Rear)	UJ492-10

2006-2005 Silverado & Sierra w/ Man. Trans.,

6.6L & 8.1L Eng.s.: [Type 2]

U-Joint (Front)Ⓛ	UJ351
(For Aluminum Drive Shaft)	UJ351C
Brute Force Non Greaseable	UJ351BF
U-Joint (Center)Ⓢ	UJ351
(For Aluminum Drive Shaft)	UJ351C
Brute Force Non Greaseable	UJ351BF
U-Joint (Rear)Ⓢ	UJ351
(For Aluminum Drive Shaft)	UJ351C
Brute Force Non Greaseable	UJ351BF

Drive Shaft (2 W/D) (Cont.)

U-Joint (Cont.)

2006-2001 Avalanche, Suburban & Yukon XL w/

8.1L Eng.: [Type 1]

U-Joint (Front)Ⓛ	UJ330
Brute Force Greaseable	UJ295
(For Aluminum Drive Shaft)	UJ330C
Clamp Kit (Front)	UJ492-10
U-Joint (Rear)Ⓢ	UJ330
Brute Force Greaseable	UJ295
(For Aluminum Drive Shaft)	UJ330C
Clamp Kit (Rear)	UJ492-10

2006-2000 Suburban & Yukon XL w/ 6.0L Eng.:

[Type 1]

U-Joint (Front)Ⓛ	UJ331
Brute Force Greaseable	UJ232
Brute Force Non Greaseable	UJ231
(For Aluminum Drive Shaft)	UJ331C
Clamp Kit (Front)	UJ492-10
U-Joint (Rear)Ⓢ	UJ331
Brute Force Greaseable	UJ232
Brute Force Non Greaseable	UJ231
(For Aluminum Drive Shaft)	UJ331C
Clamp Kit (Rear)	UJ492-10

2004-2001 Silverado & Sierra Exc. HD: [Type 2]

U-Joint (Front)Ⓛ	UJ331
Brute Force Greaseable	UJ232
Brute Force Non Greaseable	UJ231
(For Aluminum Drive Shaft)	UJ331C
U-Joint (Center)Ⓢ	UJ331
Brute Force Greaseable	UJ232
Brute Force Non Greaseable	UJ231
(For Aluminum Drive Shaft)	UJ331C
U-Joint (Rear)Ⓢ	UJ331
Brute Force Greaseable	UJ232
Brute Force Non Greaseable	UJ231
(For Aluminum Drive Shaft)	UJ331C

2004-2001 Silverado & Sierra HD w/ 6.0L Eng.

Ext. Cab & Long Bed: [Type 2]

U-Joint (Front)Ⓛ	UJ330A
Brute Force Greaseable	UJ295A
Clamp Kit (Front)	UJ492-10
U-Joint (Center)Ⓢ	UJ330A
Brute Force Greaseable	UJ295A
Clamp Kit (Center)	UJ492-10
U-Joint (Rear)Ⓢ	UJ330A
Brute Force Greaseable	UJ295A
Clamp Kit (Rear)	UJ492-10

(Continued)

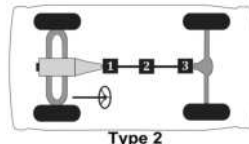
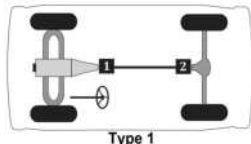

Passenger cars, light & medium trucks

(Cont.) -- Chevrolet/GMC Truck 3/4 ton

MFG./YEAR	MODEL & LOCATION	PART NO.	MFG./YEAR	MODEL & LOCATION	PART NO.
Drive Shaft (2 W/D) (Cont.)			Drive Shaft (2 W/D) (Cont.)		
U-Joint (Cont.)			U-Joint (Cont.)		
2004-2001 Silverado & Sierra HD w/ 6.0L Eng.			2000-1999 C2500, Silverado & Sierra w/ Auto.		
Exc. Ext. Cab & Long Bed: [Type 2]			Trans.: [Type 2]		
U-Joint (Front)Ⓢ		UJ330	U-Joint (Front)Ⓢ		UJ331
<i>Brute Force Greaseable</i>		UJ295	<i>Brute Force Greaseable</i>		UJ232
(For Aluminum Drive Shaft)		UJ330C	<i>Brute Force Non Greaseable</i>		UJ231
Clamp Kit (Front)		UJ492-10	(For Aluminum Drive Shaft)		UJ331C
U-Joint (Center)Ⓢ		UJ330	Clamp Kit (Front)		UJ492-10
<i>Brute Force Greaseable</i>		UJ295	U-Joint (Center)Ⓢ		UJ331
(For Aluminum Drive Shaft)		UJ330C	<i>Brute Force Greaseable</i>		UJ232
Clamp Kit (Center)		UJ492-10	<i>Brute Force Non Greaseable</i>		UJ231
U-Joint (Rear)Ⓢ		UJ330	(For Aluminum Drive Shaft)		UJ331C
<i>Brute Force Greaseable</i>		UJ295	Clamp Kit (Center)		UJ492-10
(For Aluminum Drive Shaft)		UJ330C	U-Joint (Rear)Ⓢ		UJ331
Clamp Kit (Rear)		UJ492-10	<i>Brute Force Greaseable</i>		UJ232
2004-2001 Silverado & Sierra HD w/ Auto. Trans.,			<i>Brute Force Non Greaseable</i>		UJ231
6.6L & 8.1L Eng.s.: [Type 2]			(For Aluminum Drive Shaft)		UJ331C
U-Joint (Front)Ⓢ		UJ330	Clamp Kit (Rear)		UJ492-10
<i>Brute Force Greaseable</i>		UJ295	2000-1999 C2500, Silverado & Sierra w/ Man.		
(For Aluminum Drive Shaft)		UJ330C	Trans.: [Type 2]		
Clamp Kit (Front)		UJ492-10	U-Joint (Front)Ⓢ		UJ330
U-Joint (Center)Ⓢ		UJ330	<i>Brute Force Greaseable</i>		UJ295
<i>Brute Force Greaseable</i>		UJ295	(For Aluminum Drive Shaft)		UJ330C
(For Aluminum Drive Shaft)		UJ330C	Clamp Kit (Front)		UJ492-10
Clamp Kit (Center)		UJ492-10	U-Joint (Center)Ⓢ		UJ330
U-Joint (Rear)Ⓢ		UJ330	<i>Brute Force Greaseable</i>		UJ295
<i>Brute Force Greaseable</i>		UJ295	(For Aluminum Drive Shaft)		UJ330C
(For Aluminum Drive Shaft)		UJ330C	Clamp Kit (Center)		UJ492-10
Clamp Kit (Rear)		UJ492-10	U-Joint (Rear)Ⓢ		UJ330
2004-2001 Silverado & Sierra HD w/ Man. Trans.,			<i>Brute Force Greaseable</i>		UJ295
6.6L & 8.1L Eng.s.: [Type 2]			(For Aluminum Drive Shaft)		UJ330C
U-Joint (Front)Ⓢ		UJ351	Clamp Kit (Rear)		UJ492-10
(For Aluminum Drive Shaft)		UJ351C	1999-1992 Suburban: [Type 1]		
<i>Brute Force Non Greaseable</i>		UJ351BF	U-Joint (Front)Ⓢ		UJ331
U-Joint (Center)Ⓢ		UJ351	<i>Brute Force Greaseable</i>		UJ232
(For Aluminum Drive Shaft)		UJ351C	<i>Brute Force Non Greaseable</i>		UJ231
<i>Brute Force Non Greaseable</i>		UJ351BF	(For Aluminum Drive Shaft)		UJ331C
U-Joint (Rear)Ⓢ		UJ351	Clamp Kit (Front)		UJ492-10
(For Aluminum Drive Shaft)		UJ351C	U-Joint (Rear)Ⓢ		UJ331
<i>Brute Force Non Greaseable</i>		UJ351BF	<i>Brute Force Greaseable</i>		UJ232
			<i>Brute Force Non Greaseable</i>		UJ231
			(For Aluminum Drive Shaft)		UJ331C
			Clamp Kit (Rear)		UJ492-10

(Continued)

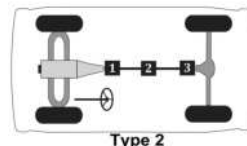
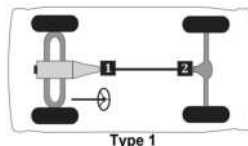

Passenger cars, light & medium trucks

Chevrolet/GMC Truck 3/4 ton -- (Cont.)

MFG./YEAR	MODEL & LOCATION	PART NO.	MFG./YEAR	MODEL & LOCATION	PART NO.
-----------	------------------	----------	-----------	------------------	----------

Drive Shaft (2 W/D) (Cont.)

U-Joint (Cont.)

1998-1991 C2500 w/ Ext. Cab: [Type 2]

U-Joint (Front) 	UJ331
Brute Force Greaseable	UJ232
Brute Force Non Greaseable	UJ231
(For Aluminum Drive Shaft)	UJ331C
Clamp Kit (Front)	UJ492-10

U-Joint (Center) 	UJ331
Brute Force Greaseable	UJ232
Brute Force Non Greaseable	UJ231
(For Aluminum Drive Shaft)	UJ331C
Clamp Kit (Center)	UJ492-10

U-Joint (Rear) 	UJ331
Brute Force Greaseable	UJ232
Brute Force Non Greaseable	UJ231
(For Aluminum Drive Shaft)	UJ331C
Clamp Kit (Rear)	UJ492-10

1998-1988 C2500 w/ Reg. Cab & 2 Joint Shaft:

[Type 1]

U-Joint (Front) 	UJ331
Brute Force Greaseable	UJ232
Brute Force Non Greaseable	UJ231
(For Aluminum Drive Shaft)	UJ331C
Clamp Kit (Front)	UJ492-10

U-Joint (Rear) 	UJ331
Brute Force Greaseable	UJ232
Brute Force Non Greaseable	UJ231
(For Aluminum Drive Shaft)	UJ331C
Clamp Kit (Rear)	UJ492-10

1998-1988 C2500 w/ Reg. Cab & 3 Joint Shaft:

[Type 2]

U-Joint (Front) 	UJ331
Brute Force Greaseable	UJ232
Brute Force Non Greaseable	UJ231
(For Aluminum Drive Shaft)	UJ331C
Clamp Kit (Front)	UJ492-10

U-Joint (Center) 	UJ331
Brute Force Greaseable	UJ232
Brute Force Non Greaseable	UJ231
(For Aluminum Drive Shaft)	UJ331C
Clamp Kit (Center)	UJ492-10



U-Joint (Rear) 	UJ331
Brute Force Greaseable	UJ232
Brute Force Non Greaseable	UJ231
(For Aluminum Drive Shaft)	UJ331C
Clamp Kit (Rear)	UJ492-10

Drive Shaft (2 W/D) (Cont.)

U-Joint (Cont.)

1991 Suburban w/ Diesel Eng.: [Type 2]

U-Joint (Front) 	UJ331
Brute Force Greaseable	UJ232
Brute Force Non Greaseable	UJ231
(For Aluminum Drive Shaft)	UJ331C
Clamp Kit (Front)	UJ492-10

U-Joint (Center) 	UJ534G
Brute Force Greaseable	UJ235
Brute Force Non Greaseable	UJ234
U-Joint (Rear) 	UJ331
Brute Force Greaseable	UJ232
Brute Force Non Greaseable	UJ231
(For Aluminum Drive Shaft)	UJ331C
Clamp Kit (Rear)	UJ492-10

1991 Suburban w/ Gas Eng.: [Type 2]

U-Joint (Front) 	UJ331
Brute Force Greaseable	UJ232
Brute Force Non Greaseable	UJ231
(For Aluminum Drive Shaft)	UJ331C
Clamp Kit (Front)	UJ492-10



U-Joint (Center) 	UJ331
Brute Force Greaseable	UJ232
Brute Force Non Greaseable	UJ231
(For Aluminum Drive Shaft)	UJ331C
Clamp Kit (Center)	UJ492-10

U-Joint (Rear) 	UJ331
Brute Force Greaseable	UJ232
Brute Force Non Greaseable	UJ231
(For Aluminum Drive Shaft)	UJ331C
Clamp Kit (Rear)	UJ492-10

1990-1989 C2500 w/ Ext. Cab & Short Bed:

[Type 2]

U-Joint (Front) 	UJ331
Brute Force Greaseable	UJ232
Brute Force Non Greaseable	UJ231
(For Aluminum Drive Shaft)	UJ331C
Clamp Kit (Front)	UJ492-10

U-Joint (Center) 	UJ534G
Brute Force Greaseable	UJ235
Brute Force Non Greaseable	UJ234
Clamp Kit (Center)	UJ530-10
U-Joint (Rear) 	UJ534G
Brute Force Greaseable	UJ235
Brute Force Non Greaseable	UJ234
Clamp Kit (Rear)	UJ530-10

(Continued)

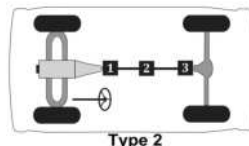
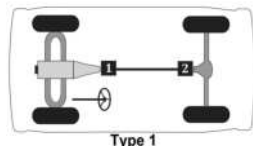

Passenger cars, light & medium trucks

(Cont.) -- Chevrolet/GMC Truck 3/4 ton

MFG./YEAR	MODEL & LOCATION	PART NO.	MFG./YEAR	MODEL & LOCATION	PART NO.
Drive Shaft (2 W/D) (Cont.)			Drive Shaft (2 W/D) (Cont.)		
U-Joint (Cont.)			U-Joint (Cont.)		
1990-1989 C2500 w/ Ext. Cab & Long Bed: [Type 2]			1990-1987 Suburban w/o 454 Eng. & Auto. Trans.: [Type 2]		
U-Joint (Front)Ⓢ		UJ331	U-Joint (Front)Ⓢ		UJ331
<i>Brute Force Greaseable</i>		UJ232	<i>Brute Force Greaseable</i>		UJ232
<i>Brute Force Non Greaseable</i>		UJ231	<i>Brute Force Non Greaseable</i>		UJ231
(For Aluminum Drive Shaft)		UJ331C	(For Aluminum Drive Shaft)		UJ331C
Clamp Kit (Front)		UJ492-10	Clamp Kit (Front)		UJ492-10
U-Joint (Center)Ⓢ		UJ331	U-Joint (Center)Ⓢ		UJ534G
<i>Brute Force Greaseable</i>		UJ232	<i>Brute Force Greaseable</i>		UJ235
<i>Brute Force Non Greaseable</i>		UJ231	<i>Brute Force Non Greaseable</i>		UJ234
(For Aluminum Drive Shaft)		UJ331C	(For Aluminum Drive Shaft)		UJ530-10
Clamp Kit (Center)		UJ492-10	Clamp Kit (Center)		UJ530-10
U-Joint (Rear)Ⓢ		UJ331	U-Joint (Rear)Ⓢ		UJ331
<i>Brute Force Greaseable</i>		UJ232	<i>Brute Force Greaseable</i>		UJ232
<i>Brute Force Non Greaseable</i>		UJ231	<i>Brute Force Non Greaseable</i>		UJ231
(For Aluminum Drive Shaft)		UJ331C	(For Aluminum Drive Shaft)		UJ331C
Clamp Kit (Rear)		UJ492-10	Clamp Kit (Rear)		UJ492-10
1990-1988 C2500 w/ Crew Cab: [Type 2]			1988 C2500 w/ Ext. Cab: [Type 2]		
U-Joint (Front)Ⓢ		UJ331	U-Joint (Front)Ⓢ		UJ331
<i>Brute Force Greaseable</i>		UJ232	<i>Brute Force Greaseable</i>		UJ232
<i>Brute Force Non Greaseable</i>		UJ231	<i>Brute Force Non Greaseable</i>		UJ231
(For Aluminum Drive Shaft)		UJ331C	(For Aluminum Drive Shaft)		UJ331C
Clamp Kit (Front)		UJ492-10	Clamp Kit (Front)		UJ492-10
U-Joint (Center)Ⓢ		UJ331	U-Joint (Center)Ⓢ		UJ331
<i>Brute Force Greaseable</i>		UJ232	<i>Brute Force Greaseable</i>		UJ232
<i>Brute Force Non Greaseable</i>		UJ231	<i>Brute Force Non Greaseable</i>		UJ231
(For Aluminum Drive Shaft)		UJ331C	(For Aluminum Drive Shaft)		UJ331C
Clamp Kit (Center)		UJ492-10	Clamp Kit (Center)		UJ492-10
U-Joint (Rear)Ⓢ		UJ331	U-Joint (Rear)Ⓢ		UJ331
<i>Brute Force Greaseable</i>		UJ232	<i>Brute Force Greaseable</i>		UJ232
<i>Brute Force Non Greaseable</i>		UJ231	<i>Brute Force Non Greaseable</i>		UJ231
(For Aluminum Drive Shaft)		UJ331C	(For Aluminum Drive Shaft)		UJ331C
Clamp Kit (Rear)		UJ492-10	Clamp Kit (Rear)		UJ492-10
1990-1987 Suburban w/ 454 Eng. & Auto. Trans.: [Type 2]			1986-1982 Suburban w/ 2 Joint Shaft: [Type 1]		
U-Joint (Front)Ⓢ		UJ331	U-Joint (Front)Ⓢ		UJ534G
<i>Brute Force Greaseable</i>		UJ232	<i>Brute Force Greaseable</i>		UJ235
<i>Brute Force Non Greaseable</i>		UJ231	<i>Brute Force Non Greaseable</i>		UJ234
(For Aluminum Drive Shaft)		UJ331C	U-Joint (Rear)Ⓢ		UJ534G
Clamp Kit (Front)		UJ492-10	<i>Brute Force Greaseable</i>		UJ235
U-Joint (Center)Ⓢ		UJ331	<i>Brute Force Non Greaseable</i>		UJ234
<i>Brute Force Greaseable</i>		UJ232			
<i>Brute Force Non Greaseable</i>		UJ231			
(For Aluminum Drive Shaft)		UJ331C			
Clamp Kit (Center)		UJ492-10			
U-Joint (Rear)Ⓢ		UJ331			
<i>Brute Force Greaseable</i>		UJ232			
<i>Brute Force Non Greaseable</i>		UJ231			
(For Aluminum Drive Shaft)		UJ331C			
Clamp Kit (Rear)		UJ492-10			

(Continued)

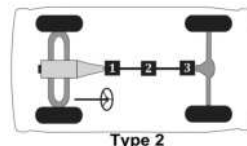
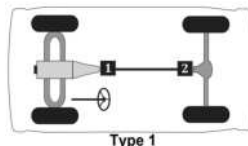

Passenger cars, light & medium trucks

Chevrolet/GMC Truck 3/4 ton -- (Cont.)

MFG./YEAR	MODEL & LOCATION	PART NO.	MFG./YEAR	MODEL & LOCATION	PART NO.
-----------	------------------	----------	-----------	------------------	----------

Drive Shaft (2 W/D) (Cont.)

U-Joint (Cont.)

1986-1982 Suburban w/ 3 Joint Shaft & 454 Eng.:

[Type 2]

U-Joint (Front)Ⓛ	UJ331
Brute Force Greaseable	UJ232
Brute Force Non Greaseable	UJ231
(For Aluminum Drive Shaft)	UJ331C
Clamp Kit (Front)	UJ492-10
U-Joint (Center)Ⓢ	UJ331
Brute Force Greaseable	UJ232
Brute Force Non Greaseable	UJ231
(For Aluminum Drive Shaft)	UJ331C
Clamp Kit (Center)	UJ492-10
U-Joint (Rear)Ⓢ	UJ331
Brute Force Greaseable	UJ232
Brute Force Non Greaseable	UJ231
(For Aluminum Drive Shaft)	UJ331C
Clamp Kit (Rear)	UJ492-10

1986-1982 Suburban w/ 3 Joint Shaft & 4 Spd.

Man. Trans. w/o 454 Eng.: [Type 2]

U-Joint (Front)Ⓛ	UJ331
Brute Force Greaseable	UJ232
Brute Force Non Greaseable	UJ231
(For Aluminum Drive Shaft)	UJ331C
Clamp Kit (Front)	UJ492-10
U-Joint (Center)Ⓢ	UJ331
Brute Force Greaseable	UJ232
Brute Force Non Greaseable	UJ231
(For Aluminum Drive Shaft)	UJ331C
Clamp Kit (Center)	UJ492-10
U-Joint (Rear)Ⓢ	UJ534G
Brute Force Greaseable	UJ235
Brute Force Non Greaseable	UJ234

1986-1982 Suburban w/ 3 Joint Shaft & THM400

Auto. Trans. w/o 454 Eng.: [Type 2]

U-Joint (Front)Ⓛ	UJ331
Brute Force Greaseable	UJ232
Brute Force Non Greaseable	UJ231
(For Aluminum Drive Shaft)	UJ331C
Clamp Kit (Front)	UJ492-10
U-Joint (Center)Ⓢ	UJ331
Brute Force Greaseable	UJ232
Brute Force Non Greaseable	UJ231
(For Aluminum Drive Shaft)	UJ331C
Clamp Kit (Center)	UJ492-10
U-Joint (Rear)Ⓢ	UJ534G
Brute Force Greaseable	UJ235
Brute Force Non Greaseable	UJ234

Drive Shaft (2 W/D) (Cont.)

U-Joint (Cont.)

1986-1982 Suburban w/ 3 Joint Shaft Exc. 454

Eng, 4 Spd. Man. Trans. & THM400

Auto. Trans.: [Type 2]

U-Joint (Front)Ⓛ	UJ534G
Brute Force Greaseable	UJ235
Brute Force Non Greaseable	UJ234
U-Joint (Center)Ⓢ	UJ331
Brute Force Greaseable	UJ232
Brute Force Non Greaseable	UJ231
(For Aluminum Drive Shaft)	UJ331C
Clamp Kit (Center)	UJ492-10
U-Joint (Rear)Ⓢ	UJ534G
Brute Force Greaseable	UJ235
Brute Force Non Greaseable	UJ234

1986-1982 C20 & C2500 w/ Inner Lock Rings:

[Type 2]

U-Joint (Front)Ⓛ	UJ534G
Brute Force Greaseable	UJ235
Brute Force Non Greaseable	UJ234
U-Joint (Center)Ⓢ	UJ534G
Brute Force Greaseable	UJ235
Brute Force Non Greaseable	UJ234
U-Joint (Rear)Ⓢ	UJ534G
Brute Force Greaseable	UJ235
Brute Force Non Greaseable	UJ234

1986-1982 C20 & C2500 w/ Outer Lock Rings:

[Type 2]

U-Joint (Front)Ⓛ	UJ331
Brute Force Greaseable	UJ232
Brute Force Non Greaseable	UJ231
(For Aluminum Drive Shaft)	UJ331C
Clamp Kit (Front)	UJ492-10
U-Joint (Center)Ⓢ	UJ331
Brute Force Greaseable	UJ232
Brute Force Non Greaseable	UJ231
(For Aluminum Drive Shaft)	UJ331C
Clamp Kit (Center)	UJ492-10
U-Joint (Rear)Ⓢ	UJ331
Brute Force Greaseable	UJ232
Brute Force Non Greaseable	UJ231
(For Aluminum Drive Shaft)	UJ331C
Clamp Kit (Rear)	UJ492-10

(Continued)

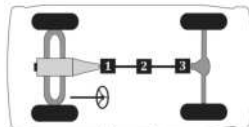

Type 2

Passenger cars, light & medium trucks

(Cont.) -- Chevrolet/GMC Truck 3/4 ton

MFG./YEAR	MODEL & LOCATION	PART NO.	MFG./YEAR	MODEL & LOCATION	PART NO.
Drive Shaft (2 W/D) (Cont.)			Drive Shaft (2 W/D) (Cont.)		
U-Joint (Cont.)			U-Joint (Cont.)		
1981	Suburban w/ Auto Trans. Exc. 454 Eng.: [Type 2]		1981	C20 & C2500 w/ 2 Doors & 4 Spd. Man. Trans.: [Type 2]	
	U-Joint (Front)Ⓢ	UJ331		U-Joint (Front)Ⓢ	UJ331
	Brute Force Greaseable	UJ232		Brute Force Greaseable	UJ232
	Brute Force Non Greaseable	UJ231		Brute Force Non Greaseable	UJ231
	(For Aluminum Drive Shaft)	UJ331C		(For Aluminum Drive Shaft)	UJ331C
	Clamp Kit (Front)	UJ492-10		Clamp Kit (Front)	UJ492-10
	U-Joint (Center)Ⓢ	UJ331		U-Joint (Center)Ⓢ	UJ331
	Brute Force Greaseable	UJ232		Brute Force Greaseable	UJ232
	Brute Force Non Greaseable	UJ231		Brute Force Non Greaseable	UJ231
	(For Aluminum Drive Shaft)	UJ331C		(For Aluminum Drive Shaft)	UJ331C
	Clamp Kit (Center)	UJ492-10		Clamp Kit (Center)	UJ492-10
	U-Joint (Rear)Ⓢ	UJ369		U-Joint (Rear)Ⓢ	UJ534G
	Brute Force Greaseable	UJ280		Brute Force Greaseable	UJ235
	Brute Force Non Greaseable	UJ269		Brute Force Non Greaseable	UJ234
	(For Aluminum Drive Shaft)	UJ369C		Clamp Kit (Rear)	UJ530-10
1981	Suburban w/ Man. Trans. Exc. 454 Eng.: [Type 2]		1981	C20 & C2500 w/ 2 Doors & THM400 Auto. Trans.: [Type 2]	
	U-Joint (Front)Ⓢ	UJ331		U-Joint (Front)Ⓢ	UJ331
	Brute Force Greaseable	UJ232		Brute Force Greaseable	UJ232
	Brute Force Non Greaseable	UJ231		Brute Force Non Greaseable	UJ231
	(For Aluminum Drive Shaft)	UJ331C		(For Aluminum Drive Shaft)	UJ331C
	Clamp Kit (Front)	UJ492-10		Clamp Kit (Front)	UJ492-10
	U-Joint (Center)Ⓢ	UJ331		U-Joint (Center)Ⓢ	UJ369
	Brute Force Greaseable	UJ232		Brute Force Greaseable	UJ280
	Brute Force Non Greaseable	UJ231		Brute Force Non Greaseable	UJ269
	(For Aluminum Drive Shaft)	UJ331C		(For Aluminum Drive Shaft)	UJ369C
	Clamp Kit (Center)	UJ492-10		U-Joint (Rear)Ⓢ	UJ534G
	U-Joint (Rear)Ⓢ	UJ534G		Brute Force Greaseable	UJ235
	Brute Force Greaseable	UJ235		Brute Force Non Greaseable	UJ234
	Brute Force Non Greaseable	UJ234		Clamp Kit (Rear)	UJ530-10
1981	Suburban w/ 454 Eng.: [Type 2]		1981	C20 & C2500 w/ 2 Doors Exc. 4 Spd. Man. Trans. & THM400 Trans.: [Type 2]	
	U-Joint (Front)Ⓢ	UJ331		U-Joint (Front)Ⓢ	UJ369
	Brute Force Greaseable	UJ232		Brute Force Greaseable	UJ280
	Brute Force Non Greaseable	UJ231		Brute Force Non Greaseable	UJ269
	(For Aluminum Drive Shaft)	UJ331C		(For Aluminum Drive Shaft)	UJ369C
	Clamp Kit (Front)	UJ492-10		U-Joint (Center)Ⓢ	UJ369
	U-Joint (Center)Ⓢ	UJ331		Brute Force Greaseable	UJ280
	Brute Force Greaseable	UJ232		Brute Force Non Greaseable	UJ269
	Brute Force Non Greaseable	UJ231		(For Aluminum Drive Shaft)	UJ369C
	(For Aluminum Drive Shaft)	UJ331C		U-Joint (Rear)Ⓢ	UJ534G
	Clamp Kit (Center)	UJ492-10		Brute Force Greaseable	UJ235
	U-Joint (Rear)Ⓢ	UJ331		Brute Force Non Greaseable	UJ234
	Brute Force Greaseable	UJ232		Clamp Kit (Rear)	UJ530-10
	Brute Force Non Greaseable	UJ231			
	(For Aluminum Drive Shaft)	UJ331C			
	Clamp Kit (Rear)	UJ492-10			

(Continued)

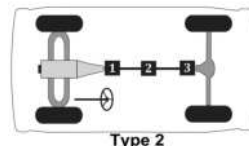

Passenger cars, light & medium trucks

Chevrolet/GMC Truck 3/4 ton -- (Cont.)

MFG./YEAR	MODEL & LOCATION	PART NO.	MFG./YEAR	MODEL & LOCATION	PART NO.
-----------	------------------	----------	-----------	------------------	----------

Drive Shaft (2 W/D) (Cont.)

U-Joint (Cont.)

1981	C20 & C2500 w/ 4 Doors 454 Eng. & 4 Spd. Man. Trans.: [Type 2]	
U-Joint (Front)Ⓛ	UJ331
<i>Brute Force Greaseable</i>	UJ232
<i>Brute Force Non Greaseable</i>	UJ231
(For Aluminum Drive Shaft)	UJ331C
Clamp Kit (Front)	UJ492-10
U-Joint (Center)Ⓞ	UJ331
<i>Brute Force Greaseable</i>	UJ232
<i>Brute Force Non Greaseable</i>	UJ231
(For Aluminum Drive Shaft)	UJ331C
Clamp Kit (Center)	UJ492-10
U-Joint (Rear)Ⓞ	UJ331
<i>Brute Force Greaseable</i>	UJ232
<i>Brute Force Non Greaseable</i>	UJ231
(For Aluminum Drive Shaft)	UJ331C
Clamp Kit (Rear)	UJ492-10
1981	C20 & C2500 w/ 4 Doors Exc. 454 Eng. & 4 Spd. Man. Trans.: [Type 2]	
U-Joint (Front)Ⓛ	UJ331
<i>Brute Force Greaseable</i>	UJ232
<i>Brute Force Non Greaseable</i>	UJ231
(For Aluminum Drive Shaft)	UJ331C
Clamp Kit (Front)	UJ492-10
U-Joint (Center)Ⓞ	UJ369
<i>Brute Force Greaseable</i>	UJ280
<i>Brute Force Non Greaseable</i>	UJ269
(For Aluminum Drive Shaft)	UJ369C
U-Joint (Rear)Ⓞ	UJ331
<i>Brute Force Greaseable</i>	UJ232
<i>Brute Force Non Greaseable</i>	UJ231
(For Aluminum Drive Shaft)	UJ331C
Clamp Kit (Rear)	UJ492-10
1980-1978 Suburban w/ THM350 Auto. Trans.: [Type 2]		
U-Joint (Front)Ⓛ	UJ369
<i>Brute Force Greaseable</i>	UJ280
<i>Brute Force Non Greaseable</i>	UJ269
(For Aluminum Drive Shaft)	UJ369C
U-Joint (Center)Ⓞ	UJ369
<i>Brute Force Greaseable</i>	UJ280
<i>Brute Force Non Greaseable</i>	UJ269
(For Aluminum Drive Shaft)	UJ369C
U-Joint (Rear)Ⓞ	UJ369
<i>Brute Force Greaseable</i>	UJ280
<i>Brute Force Non Greaseable</i>	UJ269
(For Aluminum Drive Shaft)	UJ369C

Drive Shaft (2 W/D) (Cont.)

U-Joint (Cont.)

1980-1978 Suburban w/ THM400 Auto. Trans.: [Type 2]	
U-Joint (Front)Ⓛ UJ331
<i>Brute Force Greaseable</i> UJ232
<i>Brute Force Non Greaseable</i> UJ231
(For Aluminum Drive Shaft) UJ331C
Clamp Kit (Front) UJ492-10
U-Joint (Center)Ⓞ UJ331
<i>Brute Force Greaseable</i> UJ232
<i>Brute Force Non Greaseable</i> UJ231
(For Aluminum Drive Shaft) UJ331C
Clamp Kit (Center) UJ492-10
U-Joint (Rear)Ⓞ UJ331
<i>Brute Force Greaseable</i> UJ232
<i>Brute Force Non Greaseable</i> UJ231
(For Aluminum Drive Shaft) UJ331C
Clamp Kit (Rear) UJ492-10
1980-1978 Suburban w/ 4 Spd. Man. Trans.: [Type 2]	
U-Joint (Front)Ⓛ UJ331
<i>Brute Force Greaseable</i> UJ232
<i>Brute Force Non Greaseable</i> UJ231
(For Aluminum Drive Shaft) UJ331C
Clamp Kit (Front) UJ492-10
U-Joint (Center)Ⓞ UJ331
<i>Brute Force Greaseable</i> UJ232
<i>Brute Force Non Greaseable</i> UJ231
(For Aluminum Drive Shaft) UJ331C
Clamp Kit (Center) UJ492-10
U-Joint (Rear)Ⓞ UJ331
<i>Brute Force Greaseable</i> UJ232
<i>Brute Force Non Greaseable</i> UJ231
(For Aluminum Drive Shaft) UJ331C
Clamp Kit (Rear) UJ492-10
1980-1978 C20 & C2500 w/ 2 Joint Shaft: [Type 1]	
U-Joint (Front)Ⓛ UJ369
<i>Brute Force Greaseable</i> UJ280
<i>Brute Force Non Greaseable</i> UJ269
(For Aluminum Drive Shaft) UJ369C
U-Joint (Rear)Ⓞ UJ369
<i>Brute Force Greaseable</i> UJ280
<i>Brute Force Non Greaseable</i> UJ269
(For Aluminum Drive Shaft) UJ369C

(Continued)

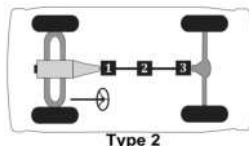
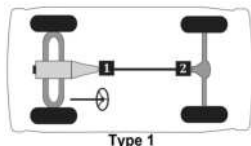

Passenger cars, light & medium trucks

(Cont.) -- Chevrolet/GMC Truck 3/4 ton

MFG./YEAR	MODEL & LOCATION	PART NO.	MFG./YEAR	MODEL & LOCATION	PART NO.
Drive Shaft (2 W/D) (Cont.)			Drive Shaft (2 W/D) (Cont.)		
U-Joint (Cont.)			U-Joint (Cont.)		
1980-1978 C20 & C2500 w/ 3 Joint Shaft & 1.063"			1977-1973 C20, C25 & Suburban w/o 400 Eng.:		
Dia. Brg. Cap: [Type 2]			[Type 2]		
U-Joint (Front)Ⓢ		UJ369	U-Joint (Front)Ⓢ		UJ369
Brute Force Greaseable		UJ280	Brute Force Greaseable		UJ280
Brute Force Non Greaseable		UJ269	Brute Force Non Greaseable		UJ269
(For Aluminum Drive Shaft)		UJ369C	(For Aluminum Drive Shaft)		UJ369C
U-Joint (Center)Ⓢ		UJ369	U-Joint (Center)Ⓢ		UJ369
Brute Force Greaseable		UJ280	Brute Force Greaseable		UJ280
Brute Force Non Greaseable		UJ269	Brute Force Non Greaseable		UJ269
(For Aluminum Drive Shaft)		UJ369C	(For Aluminum Drive Shaft)		UJ369C
U-Joint (Rear)Ⓢ		UJ369	U-Joint (Rear)Ⓢ		UJ331
Brute Force Greaseable		UJ280	Brute Force Greaseable		UJ232
Brute Force Non Greaseable		UJ269	Brute Force Non Greaseable		UJ231
(For Aluminum Drive Shaft)		UJ369C	(For Aluminum Drive Shaft)		UJ331C
1980-1978 C20 & C2500 w/ 3 Joint Shaft & 1.188"			1972-1967 C20, C25 & Suburban w/ Auto. Trans.:		
Dia. Brg. Cap: [Type 2]			[Type 2]		
U-Joint (Front)Ⓢ		UJ369	U-Joint (Front)Ⓢ		UJ369
Brute Force Greaseable		UJ280	Brute Force Greaseable		UJ280
Brute Force Non Greaseable		UJ269	Brute Force Non Greaseable		UJ269
(For Aluminum Drive Shaft)		UJ369C	(For Aluminum Drive Shaft)		UJ369C
U-Joint (Center)Ⓢ		UJ369	U-Bolt Kit (Front)		UJ329-10
Brute Force Greaseable		UJ280	U-Joint (Center)Ⓢ		UJ369
Brute Force Non Greaseable		UJ269	Brute Force Greaseable		UJ280
(For Aluminum Drive Shaft)		UJ369C	Brute Force Non Greaseable		UJ269
U-Joint (Rear)Ⓢ		UJ534G	(For Aluminum Drive Shaft)		UJ369C
Brute Force Greaseable		UJ235	U-Bolt Kit (Center)		UJ329-10
Brute Force Non Greaseable		UJ234	U-Joint (Rear)Ⓢ		UJ369
1977-1976 C20, C25 & Suburban w/ 400 Eng.:			Brute Force Greaseable		UJ280
[Type 2]			Brute Force Non Greaseable		UJ269
U-Joint (Front)Ⓢ		UJ354	(For Aluminum Drive Shaft)		UJ369C
Brute Force Greaseable		UJ270	U-Bolt Kit (Rear)		UJ329-10
Brute Force Non Greaseable		UJ254	1972-1967 C20, C25 & Suburban w/ Std. 3 Spd.		
(For Aluminum Drive Shaft)		UJ354C	Man. Trans.: [Type 2]		
U-Joint (Center)Ⓢ		UJ331	U-Joint (Front)Ⓢ		UJ369
Brute Force Greaseable		UJ232	Brute Force Greaseable		UJ280
Brute Force Non Greaseable		UJ231	Brute Force Non Greaseable		UJ269
(For Aluminum Drive Shaft)		UJ331C	(For Aluminum Drive Shaft)		UJ369C
U-Joint (Rear)Ⓢ		UJ331	U-Bolt Kit (Front)		UJ329-10
Brute Force Greaseable		UJ232	U-Joint (Center)Ⓢ		UJ369
Brute Force Non Greaseable		UJ231	Brute Force Greaseable		UJ280
(For Aluminum Drive Shaft)		UJ331C	Brute Force Non Greaseable		UJ269
			(For Aluminum Drive Shaft)		UJ369C
			U-Bolt Kit (Center)		UJ329-10
			U-Joint (Rear)Ⓢ		UJ369
			Brute Force Greaseable		UJ280
			Brute Force Non Greaseable		UJ269
			(For Aluminum Drive Shaft)		UJ369C
			U-Bolt Kit (Rear)		UJ329-10
					(Continued)

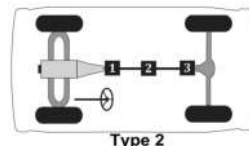

Type 2

Passenger cars, light & medium trucks

Chevrolet/GMC Truck 3/4 ton -- (Cont.)

MFG./YEAR	MODEL & LOCATION	PART NO.	MFG./YEAR	MODEL & LOCATION	PART NO.
-----------	------------------	----------	-----------	------------------	----------

Drive Shaft (2 W/D) (Cont.)

U-Joint (Cont.)

1972-1967 C20, C25 & Suburban w/ HD 3 Spd.

Man. & 4 Spd. Man. Trans.: [Type 2]

U-Joint (Front)Ⓚ	UJ331
Brute Force Greaseable	UJ232
Brute Force Non Greaseable	UJ231
(For Aluminum Drive Shaft)	UJ331C
U-Bolt Kit (Front)	UJ330-10
U-Joint (Center)Ⓚ	UJ331
Brute Force Greaseable	UJ232
Brute Force Non Greaseable	UJ231
(For Aluminum Drive Shaft)	UJ331C
U-Bolt Kit (Center)	UJ330-10
U-Joint (Rear)Ⓚ	UJ331
Brute Force Greaseable	UJ232
Brute Force Non Greaseable	UJ231
(For Aluminum Drive Shaft)	UJ331C
U-Bolt Kit (Rear)	UJ330-10

Drive Shaft (4 W/D)

U-Joint

2019-2007 Silverado & Sierra w/ Gas Eng. Exc.

Crew Cab w/ Long Bed: [Type 13]

U-Joint (Fr. Shaft; Frt.)Ⓚ	UJ534G
Brute Force Greaseable	UJ235
Brute Force Non Greaseable	UJ234
Clamp Kit (Fr. Shaft; Frt.)	UJ530-10
U-Joint (Fr. Shaft; Rr.)Ⓚ	UJ534G
Brute Force Greaseable	UJ235
Brute Force Non Greaseable	UJ234
Clamp Kit (Fr. Shaft; Rr.)	UJ530-10
U-Joint (Rr. Shaft; Frt.)Ⓚ	UJ330A
Brute Force Greaseable	UJ295A
Clamp Kit (Rr. Shaft; Frt.)	UJ492-10
U-Joint (Rr. Shaft; Rr.)Ⓚ	UJ330A
Brute Force Greaseable	UJ295A
Clamp Kit (Rr. Shaft; Rr.)	UJ492-10

2019-2007 Silverado & Sierra w/ Diesel Eng. Exc.

Crew Cab w/ Long Bed: [Type 13]

U-Joint (Fr. Shaft; Frt.)Ⓚ	UJ534G
Brute Force Greaseable	UJ235
Brute Force Non Greaseable	UJ234
Clamp Kit (Fr. Shaft; Frt.)	UJ530-10
U-Joint (Fr. Shaft; Rr.)Ⓚ	UJ534G
Brute Force Greaseable	UJ235
Brute Force Non Greaseable	UJ234
Clamp Kit (Fr. Shaft; Rr.)	UJ530-10
U-Joint (Rr. Shaft; Frt.)Ⓚ	UJ351A
Brute Force Non Greaseable	UJ351ABF
Clamp Kit (Rr. Shaft; Frt.)	UJ352-10
U-Joint (Rr. Shaft; Rr.)Ⓚ	UJ351A
Brute Force Non Greaseable	UJ351ABF
Clamp Kit (Rr. Shaft; Rr.)	UJ352-10

Drive Shaft (4 W/D) (Cont.)

U-Joint (Cont.)

2019-2007 Silverado & Sierra w/ Crew Cab, Long

Bed & Gas. Eng: [Type 14]

U-Joint (Fr. Shaft; Frt.)Ⓚ	UJ534G
Brute Force Greaseable	UJ235
Brute Force Non Greaseable	UJ234
Clamp Kit (Fr. Shaft; Frt.)	UJ530-10
U-Joint (Fr. Shaft; Rr.)Ⓚ	UJ534G
Brute Force Greaseable	UJ235
Brute Force Non Greaseable	UJ234
Clamp Kit (Fr. Shaft; Rr.)	UJ530-10
U-Joint (Rr. Shaft; Frt.)Ⓚ	UJ330A
Brute Force Greaseable	UJ295A
Clamp Kit (Rr. Shaft; Frt.)	UJ492-10
U-Joint (Rr. Shaft; Ctr.)Ⓚ	UJ330A
Brute Force Greaseable	UJ295A
Clamp Kit (Rr. Shaft; Ctr.)	UJ492-10
U-Joint (Rr. Shaft; Rr.)Ⓚ	UJ330A
Brute Force Greaseable	UJ295A
Clamp Kit (Rr. Shaft; Rr.)	UJ492-10

2019-2007 Silverado & Sierra w/ Crew Cab, Long

Bed & Diesel Eng.: [Type 14]

U-Joint (Fr. Shaft; Frt.)Ⓚ	UJ534G
Brute Force Greaseable	UJ235
Brute Force Non Greaseable	UJ234
Clamp Kit (Fr. Shaft; Frt.)	UJ530-10
U-Joint (Fr. Shaft; Rr.)Ⓚ	UJ534G
Brute Force Greaseable	UJ235
Brute Force Non Greaseable	UJ234
Clamp Kit (Fr. Shaft; Rr.)	UJ530-10
U-Joint (Rr. Shaft; Frt.)Ⓚ	UJ351A
Brute Force Non Greaseable	UJ351ABF
Clamp Kit (Rr. Shaft; Frt.)	UJ352-10
U-Joint (Rr. Shaft; Ctr.)Ⓚ	UJ351A
Brute Force Non Greaseable	UJ351ABF
Clamp Kit (Rr. Shaft; Ctr.)	UJ352-10
U-Joint (Rr. Shaft; Rr.)Ⓚ	UJ351A
Brute Force Non Greaseable	UJ351ABF
Clamp Kit (Rr. Shaft; Rr.)	UJ352-10

(Continued)

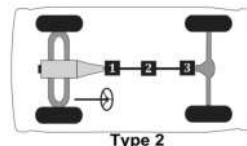
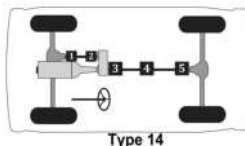
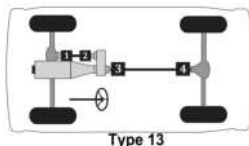

Passenger cars, light & medium trucks

(Cont.) -- Chevrolet/GMC Truck 3/4 ton

MFG./YEAR	MODEL & LOCATION	PART NO.	MFG./YEAR	MODEL & LOCATION	PART NO.
Drive Shaft (4 W/D) (Cont.)			Drive Shaft (4 W/D) (Cont.)		
U-Joint (Cont.)			U-Joint (Cont.)		
2013-2008 Suburban & Yukon XL: [Type 13]			2007 Silverado & Sierra Classic w/ Reg. Cab & 5 Spd. Man. Trans.: [Type 13]		
	U-Joint (Frnt. Shaft; Frnt.) ①	UJ534G		U-Joint (Frnt. Shaft; Frnt.) ①	UJ534G
	Brute Force Greaseable	UJ235		Brute Force Greaseable	UJ235
	Brute Force Non Greaseable	UJ234		Brute Force Non Greaseable	UJ234
	Clamp Kit (Frnt. Shaft; Frnt.)	UJ530-10		Clamp Kit (Frnt. Shaft; Frnt.)	UJ530-10
	U-Joint (Frnt. Shaft; Rr.) ②	UJ534G		U-Joint (Frnt. Shaft; Rr.) ②	UJ534G
	Brute Force Greaseable	UJ235		Brute Force Greaseable	UJ235
	Brute Force Non Greaseable	UJ234		Brute Force Non Greaseable	UJ234
	Clamp Kit (Frnt. Shaft; Rr.)	UJ530-10		Clamp Kit (Frnt. Shaft; Rr.)	UJ530-10
	U-Joint (Rr. Shaft; Frnt.) ③	UJ330A		U-Joint (Rr. Shaft; Frnt.) ③	UJ330A
	Brute Force Greaseable	UJ295A		Brute Force Greaseable	UJ295A
	Clamp Kit (Rr. Shaft; Frnt.)	UJ492-10		Clamp Kit (Rr. Shaft; Frnt.)	UJ492-10
	U-Joint (Rr. Shaft; Rr.) ④	UJ330		U-Joint (Rr. Shaft; Rr.) ④	UJ330A
	Brute Force Greaseable	UJ295		Brute Force Greaseable	UJ295A
	(For Aluminum Drive Shaft)	UJ330C		Clamp Kit (Rr. Shaft; Rr.)	UJ492-10
	2007 Suburban & Yukon XL: [Type 13]			2007 Silverado & Sierra Classic w/ Reg. Cab & 6 Spd. Auto. Trans.: [Type 13]	
	U-Joint (Frnt. Shaft; Frnt.) ①	UJ534G		U-Joint (Frnt. Shaft; Frnt.) ①	UJ534G
	Brute Force Greaseable	UJ235		Brute Force Greaseable	UJ235
	Brute Force Non Greaseable	UJ234		Brute Force Non Greaseable	UJ234
	Clamp Kit (Frnt. Shaft; Frnt.)	UJ530-10		Clamp Kit (Frnt. Shaft; Frnt.)	UJ530-10
	U-Joint (Frnt. Shaft; Rr.) ②	UJ534G		U-Joint (Frnt. Shaft; Rr.) ②	UJ534G
	Brute Force Greaseable	UJ235		Brute Force Greaseable	UJ235
	Brute Force Non Greaseable	UJ234		Brute Force Non Greaseable	UJ234
	Clamp Kit (Frnt. Shaft; Rr.)	UJ530-10		Clamp Kit (Frnt. Shaft; Rr.)	UJ530-10
	U-Joint (Rr. Shaft; Frnt.) ③	UJ331A		U-Joint (Rr. Shaft; Frnt.) ③	UJ351
	Brute Force Greaseable	UJ232A		(For Aluminum Drive Shaft)	UJ351C
	Clamp Kit (Rr. Shaft; Frnt.)	UJ492-10		Brute Force Non Greaseable	UJ351BF
	U-Joint (Rr. Shaft; Rr.) ④	UJ331A		U-Joint (Rr. Shaft; Rr.) ④	UJ351
	Brute Force Greaseable	UJ232A		(For Aluminum Drive Shaft)	UJ351C
	Clamp Kit (Rr. Shaft; Rr.)	UJ492-10		Brute Force Non Greaseable	UJ351BF
	2007 Silverado & Sierra Classic w/ Reg. Cab & 4 Spd. Auto. Trans.: [Type 13]			2007 Silverado & Sierra Classic w/ Ext. Cab, Std. Bed & 4 Spd. Auto. Trans.: [Type 13]	
	U-Joint (Frnt. Shaft; Frnt.) ①	UJ534G		U-Joint (Frnt. Shaft; Frnt.) ①	UJ534G
	Brute Force Greaseable	UJ235		Brute Force Greaseable	UJ235
	Brute Force Non Greaseable	UJ234		Brute Force Non Greaseable	UJ234
	Clamp Kit (Frnt. Shaft; Frnt.)	UJ530-10		Clamp Kit (Frnt. Shaft; Frnt.)	UJ530-10
	U-Joint (Frnt. Shaft; Rr.) ②	UJ534G		U-Joint (Frnt. Shaft; Rr.) ②	UJ534G
	Brute Force Greaseable	UJ235		Brute Force Greaseable	UJ235
	Brute Force Non Greaseable	UJ234		Brute Force Non Greaseable	UJ234
	Clamp Kit (Frnt. Shaft; Rr.)	UJ530-10		Clamp Kit (Frnt. Shaft; Rr.)	UJ530-10
	U-Joint (Rr. Shaft; Frnt.) ③	UJ330A		U-Joint (Rr. Shaft; Frnt.) ③	UJ330
	Brute Force Greaseable	UJ295A		Brute Force Greaseable	UJ295
	Clamp Kit (Rr. Shaft; Frnt.)	UJ492-10		(For Aluminum Drive Shaft)	UJ330C
	U-Joint (Rr. Shaft; Rr.) ④	UJ330A		Clamp Kit (Rr. Shaft; Frnt.)	UJ492-10
	Brute Force Greaseable	UJ295A		U-Joint (Rr. Shaft; Rr.) ④	UJ330
	Clamp Kit (Rr. Shaft; Rr.)	UJ492-10		Brute Force Greaseable	UJ295
				(For Aluminum Drive Shaft)	UJ330C
				Clamp Kit (Rr. Shaft; Rr.)	UJ492-10

(Continued)

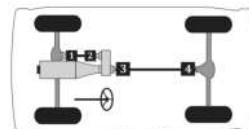

Type 13

Passenger cars, light & medium trucks

Chevrolet/GMC Truck 3/4 ton -- (Cont.)

MFG./YEAR	MODEL & LOCATION	PART NO.	MFG./YEAR	MODEL & LOCATION	PART NO.
-----------	------------------	----------	-----------	------------------	----------

Drive Shaft (4 W/D) (Cont.)

U-Joint (Cont.)

2007	Silverado & Sierra Classic w/ Ext. Cab, Std. Bed & 5 Spd. Man. Trans.:	
	[Type 13]	
	U-Joint (Fr. Shaft; Frt.)	UJ534G
	<i>Brute Force Greaseable</i>	UJ235
	<i>Brute Force Non Greaseable</i>	UJ234
	Clamp Kit (Fr. Shaft; Frt.)	UJ530-10
	U-Joint (Fr. Shaft; Rr.)	UJ534G
	<i>Brute Force Greaseable</i>	UJ235
	<i>Brute Force Non Greaseable</i>	UJ234
	Clamp Kit (Fr. Shaft; Rr.)	UJ530-10
	U-Joint (Rr. Shaft; Frt.)	UJ330
	<i>Brute Force Greaseable</i>	UJ295
	(For Aluminum Drive Shaft)	UJ330C
	Clamp Kit (Rr. Shaft; Frt.)	UJ492-10
	U-Joint (Rr. Shaft; Rr.)	UJ330
	<i>Brute Force Greaseable</i>	UJ295
	(For Aluminum Drive Shaft)	UJ330C
	Clamp Kit (Rr. Shaft; Rr.)	UJ492-10

2007	Silverado & Sierra Classic w/ Ext. Cab, Std. Bed & 6 Spd. Auto. Trans.:	
	[Type 13]	
	U-Joint (Fr. Shaft; Frt.)	UJ534G
	<i>Brute Force Greaseable</i>	UJ235
	<i>Brute Force Non Greaseable</i>	UJ234
	Clamp Kit (Fr. Shaft; Frt.)	UJ530-10
	U-Joint (Fr. Shaft; Rr.)	UJ534G
	<i>Brute Force Greaseable</i>	UJ235
	<i>Brute Force Non Greaseable</i>	UJ234
	Clamp Kit (Fr. Shaft; Rr.)	UJ530-10
	U-Joint (Rr. Shaft; Frt.)	UJ351
	(For Aluminum Drive Shaft)	UJ351C
	<i>Brute Force Non Greaseable</i>	UJ351BF
	U-Joint (Rr. Shaft; Rr.)	UJ351
	(For Aluminum Drive Shaft)	UJ351C
	<i>Brute Force Non Greaseable</i>	UJ351BF

Drive Shaft (4 W/D) (Cont.)

U-Joint (Cont.)

2007	Silverado & Sierra Classic w/ Ext. Cab, Long Bed & Auto. Trans.:	
	[Type 13]	
	U-Joint (Fr. Shaft; Frt.)	UJ534G
	<i>Brute Force Greaseable</i>	UJ235
	<i>Brute Force Non Greaseable</i>	UJ234
	Clamp Kit (Fr. Shaft; Frt.)	UJ530-10
	U-Joint (Fr. Shaft; Rr.)	UJ534G
	<i>Brute Force Greaseable</i>	UJ235
	<i>Brute Force Non Greaseable</i>	UJ234
	Clamp Kit (Fr. Shaft; Rr.)	UJ530-10
	U-Joint (Rr. Shaft; Frt.)	UJ330
	<i>Brute Force Greaseable</i>	UJ295
	(For Aluminum Drive Shaft)	UJ330C
	Clamp Kit (Rr. Shaft; Frt.)	UJ492-10
	U-Joint (Rr. Shaft; Rr.)	UJ330
	<i>Brute Force Greaseable</i>	UJ295
	(For Aluminum Drive Shaft)	UJ330C
	Clamp Kit (Rr. Shaft; Rr.)	UJ492-10

2007	Silverado & Sierra Classic w/ Ext. Cab, Long Bed & 5 Spd. Man. Trans.:	
	[Type 14]	
	U-Joint (Fr. Shaft; Frt.)	UJ534G
	<i>Brute Force Greaseable</i>	UJ235
	<i>Brute Force Non Greaseable</i>	UJ234
	Clamp Kit (Fr. Shaft; Frt.)	UJ530-10
	U-Joint (Fr. Shaft; Rr.)	UJ534G
	<i>Brute Force Greaseable</i>	UJ235
	<i>Brute Force Non Greaseable</i>	UJ234
	Clamp Kit (Fr. Shaft; Rr.)	UJ530-10
	U-Joint (Rr. Shaft; Frt.)	UJ330
	<i>Brute Force Greaseable</i>	UJ295
	(For Aluminum Drive Shaft)	UJ330C
	Clamp Kit (Rr. Shaft; Frt.)	UJ492-10
	U-Joint (Rr. Shaft; Ctr.)	UJ330
	<i>Brute Force Greaseable</i>	UJ295
	(For Aluminum Drive Shaft)	UJ330C
	Clamp Kit (Rr. Shaft; Ctr.)	UJ492-10
	U-Joint (Rr. Shaft; Rr.)	UJ330
	<i>Brute Force Greaseable</i>	UJ295
	(For Aluminum Drive Shaft)	UJ330C
	Clamp Kit (Rr. Shaft; Rr.)	UJ492-10

(Continued)

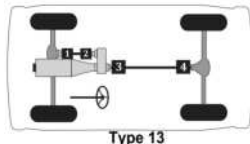

Type 13

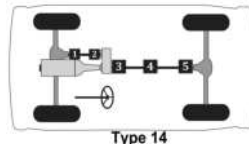

Type 14

Passenger cars, light & medium trucks

(Cont.) -- Chevrolet/GMC Truck 3/4 ton

MFG./YEAR	MODEL & LOCATION	PART NO.	MFG./YEAR	MODEL & LOCATION	PART NO.
Drive Shaft (4 W/D) (Cont.)			Drive Shaft (4 W/D) (Cont.)		
U-Joint (Cont.)			U-Joint (Cont.)		
2007	Silverado & Sierra Classic w/ Crew Cab, Std. Bed & Auto. Trans.: [Type 13]		2007	Silverado & Sierra Classic w/ Crew Cab & Man. Trans.: [Type 14]	
	U-Joint (Frnt. Shaft; Frt.) ①	UJ534G		U-Joint (Frnt. Shaft; Frt.) ①	UJ534G
	Brute Force Greaseable	UJ235		Brute Force Greaseable	UJ235
	Brute Force Non Greaseable	UJ234		Brute Force Non Greaseable	UJ234
	Clamp Kit (Frnt. Shaft; Frt.)	UJ530-10		Clamp Kit (Frnt. Shaft; Frt.)	UJ530-10
	U-Joint (Frnt. Shaft; Rr.) ②	UJ534G		U-Joint (Frnt. Shaft; Rr.) ②	UJ534G
	Brute Force Greaseable	UJ235		Brute Force Greaseable	UJ235
	Brute Force Non Greaseable	UJ234		Brute Force Non Greaseable	UJ234
	Clamp Kit (Frnt. Shaft; Rr.)	UJ530-10		Clamp Kit (Frnt. Shaft; Rr.)	UJ530-10
	U-Joint (Rr. Shaft; Frt.) ③	UJ330		U-Joint (Rr. Shaft; Frt.) ③	UJ330
	Brute Force Greaseable	UJ295		Brute Force Greaseable	UJ295
	(For Aluminum Drive Shaft)	UJ330C		(For Aluminum Drive Shaft)	UJ330C
	Clamp Kit (Rr. Shaft; Frt.)	UJ492-10		Clamp Kit (Rr. Shaft; Frt.)	UJ492-10
	U-Joint (Rr. Shaft; Rr.) ④	UJ330		U-Joint (Rr. Shaft; Rr.) ④	UJ330
	Brute Force Greaseable	UJ295		Brute Force Greaseable	UJ295
	(For Aluminum Drive Shaft)	UJ330C		(For Aluminum Drive Shaft)	UJ330C
	Clamp Kit (Rr. Shaft; Rr.)	UJ492-10		Clamp Kit (Rr. Shaft; Rr.)	UJ492-10
2007	Silverado & Sierra Classic w/ Crew Cab, Long Bed & Auto. Trans.: [Type 14]		2006-2005	Silverado & Sierra w/ Reg. Cab & 4 Spd. Auto. Trans.: [Type 13]	
	U-Joint (Frnt. Shaft; Frt.) ①	UJ534G		U-Joint (Frnt. Shaft; Frt.) ①	UJ534G
	Brute Force Greaseable	UJ235		Brute Force Greaseable	UJ235
	Brute Force Non Greaseable	UJ234		Brute Force Non Greaseable	UJ234
	Clamp Kit (Frnt. Shaft; Frt.)	UJ530-10		Clamp Kit (Frnt. Shaft; Frt.)	UJ530-10
	U-Joint (Frnt. Shaft; Rr.) ②	UJ534G		U-Joint (Frnt. Shaft; Rr.) ②	UJ534G
	Brute Force Greaseable	UJ235		Brute Force Greaseable	UJ235
	Brute Force Non Greaseable	UJ234		Brute Force Non Greaseable	UJ234
	Clamp Kit (Frnt. Shaft; Rr.)	UJ530-10		Clamp Kit (Frnt. Shaft; Rr.)	UJ530-10
	U-Joint (Rr. Shaft; Frt.) ③	UJ330		U-Joint (Rr. Shaft; Frt.) ③	UJ330A
	Brute Force Greaseable	UJ295		Brute Force Greaseable	UJ295A
	(For Aluminum Drive Shaft)	UJ330C		(For Aluminum Drive Shaft)	UJ330A
	Clamp Kit (Rr. Shaft; Frt.)	UJ492-10		Clamp Kit (Rr. Shaft; Frt.)	UJ492-10
	U-Joint (Rr. Shaft; Rr.) ④	UJ330		U-Joint (Rr. Shaft; Rr.) ④	UJ330A
	Brute Force Greaseable	UJ295		Brute Force Greaseable	UJ295A
	(For Aluminum Drive Shaft)	UJ330C		(For Aluminum Drive Shaft)	UJ330A
	Clamp Kit (Rr. Shaft; Rr.)	UJ492-10		Clamp Kit (Rr. Shaft; Rr.)	UJ492-10

(Continued)

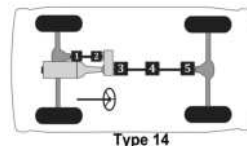
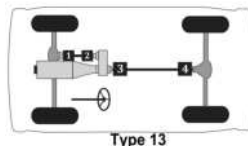

Passenger cars, light & medium trucks

Chevrolet/GMC Truck 3/4 ton -- (Cont.)

MFG./YEAR	MODEL & LOCATION	PART NO.	MFG./YEAR	MODEL & LOCATION	PART NO.
Drive Shaft (4 W/D) (Cont.)			Drive Shaft (4 W/D) (Cont.)		
U-Joint (Cont.)			U-Joint (Cont.)		
2006-2005 Silverado & Sierra w/ Reg. Cab, 5 Spd. & 6 Spd. Auto Trans.: [Type 13]			2006-2005 Silverado & Sierra w/ Ext. Cab, Std. Bed & 4 Spd. Auto Trans.: [Type 13]		
U-Joint (Fr. Shaft; Frt.)⊙		UJ534G	U-Joint (Fr. Shaft; Frt.)⊙		UJ534G
Brute Force Greaseable		UJ235	Brute Force Greaseable		UJ235
Brute Force Non Greaseable		UJ234	Brute Force Non Greaseable		UJ234
Clamp Kit (Fr. Shaft; Frt.)		UJ530-10	Clamp Kit (Fr. Shaft; Frt.)		UJ530-10
U-Joint (Fr. Shaft; Rr.)⊙		UJ534G	U-Joint (Fr. Shaft; Rr.)⊙		UJ534G
Brute Force Greaseable		UJ235	Brute Force Greaseable		UJ235
Brute Force Non Greaseable		UJ234	Brute Force Non Greaseable		UJ234
Clamp Kit (Fr. Shaft; Rr.)		UJ530-10	Clamp Kit (Fr. Shaft; Rr.)		UJ530-10
U-Joint (Rr. Shaft; Frt.)⊙		UJ351	U-Joint (Rr. Shaft; Frt.)⊙		UJ330
(For Aluminum Drive Shaft)		UJ351C	Brute Force Greaseable		UJ295
Brute Force Non Greaseable		UJ351BF	(For Aluminum Drive Shaft)		UJ330C
U-Joint (Rr. Shaft; Rr.)⊙		UJ351	Clamp Kit (Rr. Shaft; Frt.)		UJ492-10
(For Aluminum Drive Shaft)		UJ351C	U-Joint (Rr. Shaft; Rr.)⊙		UJ330
Brute Force Non Greaseable		UJ351BF	Brute Force Greaseable		UJ295
2006-2005 Silverado & Sierra w/ Reg. Cab & 5 Spd. Man. Trans.: [Type 13]			(For Aluminum Drive Shaft)		UJ330C
U-Joint (Fr. Shaft; Frt.)⊙		UJ534G	Clamp Kit (Rr. Shaft; Rr.)		UJ492-10
Brute Force Greaseable		UJ235	2006-2005 Silverado & Sierra w/ Ext. Cab, Std. Bed, 5 Spd. & 6 Spd. Auto Trans.: [Type 13]		
Brute Force Non Greaseable		UJ234	U-Joint (Fr. Shaft; Frt.)⊙		UJ534G
Clamp Kit (Fr. Shaft; Frt.)		UJ530-10	Brute Force Greaseable		UJ235
U-Joint (Fr. Shaft; Rr.)⊙		UJ534G	Brute Force Non Greaseable		UJ234
Brute Force Greaseable		UJ235	Clamp Kit (Fr. Shaft; Frt.)		UJ530-10
Brute Force Non Greaseable		UJ234	U-Joint (Fr. Shaft; Rr.)⊙		UJ534G
Clamp Kit (Fr. Shaft; Rr.)		UJ530-10	Brute Force Greaseable		UJ235
U-Joint (Rr. Shaft; Frt.)⊙		UJ330	Brute Force Non Greaseable		UJ234
Brute Force Greaseable		UJ295	Clamp Kit (Fr. Shaft; Rr.)		UJ530-10
(For Aluminum Drive Shaft)		UJ330C	U-Joint (Rr. Shaft; Frt.)⊙		UJ351
Clamp Kit (Rr. Shaft; Frt.)		UJ492-10	(For Aluminum Drive Shaft)		UJ351C
U-Joint (Rr. Shaft; Rr.)⊙		UJ330	Brute Force Non Greaseable		UJ351BF
Brute Force Greaseable		UJ295	U-Joint (Rr. Shaft; Rr.)⊙		UJ351
(For Aluminum Drive Shaft)		UJ330C	(For Aluminum Drive Shaft)		UJ351C
Clamp Kit (Rr. Shaft; Rr.)		UJ492-10	Brute Force Non Greaseable		UJ351BF
2006-2005 Silverado & Sierra w/ Reg. Cab & 6 Spd. Man. Trans.: [Type 13]					(Continued)
U-Joint (Fr. Shaft; Frt.)⊙		UJ534G			
Brute Force Greaseable		UJ235			
Brute Force Non Greaseable		UJ234			
Clamp Kit (Fr. Shaft; Frt.)		UJ530-10			
U-Joint (Fr. Shaft; Rr.)⊙		UJ534G			
Brute Force Greaseable		UJ235			
Brute Force Non Greaseable		UJ234			
Clamp Kit (Fr. Shaft; Rr.)		UJ530-10			
U-Joint (Rr. Shaft; Frt.)⊙		UJ351			
(For Aluminum Drive Shaft)		UJ351C			
Brute Force Non Greaseable		UJ351BF			
U-Joint (Rr. Shaft; Rr.)⊙		UJ351			
(For Aluminum Drive Shaft)		UJ351C			
Brute Force Non Greaseable		UJ351BF			

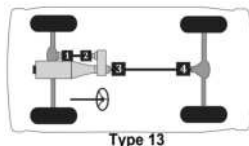

172 ▲ For Use w/ 1.063" Bearing Cap Application. ⊙ For Use w/ 1.188" Bearing Cap Application. ◇ For Use w/ Inner Lock Ring Application on Half Shaft. □ For Use w/ Outer Lock Ring Application on Half Shaft.

MFG./YEAR	MODEL & LOCATION	PART NO.	MFG./YEAR	MODEL & LOCATION	PART NO.
Drive Shaft (4 W/D) (Cont.)			Drive Shaft (4 W/D) (Cont.)		
U-Joint (Cont.)			U-Joint (Cont.)		
2006-2005 Silverado & Sierra w/ Ext. Cab, Std.			2006-2005 Silverado & Sierra w/ Ext. Cab, Long		
Bed & 5 Spd. Man. Trans.: [Type 13]			Bed & 5 Spd. Man. Trans.: [Type 13]		
	U-Joint (Frt. Shaft; Frt.) ①	UJ534G		U-Joint (Frt. Shaft; Frt.) ①	UJ534G
	<i>Brute Force Greaseable</i>	UJ235		<i>Brute Force Greaseable</i>	UJ235
	<i>Brute Force Non Greaseable</i>	UJ234		<i>Brute Force Non Greaseable</i>	UJ234
	Clamp Kit (Frt. Shaft; Frt.)	UJ530-10		Clamp Kit (Frt. Shaft; Frt.)	UJ530-10
	U-Joint (Frt. Shaft; Rr.) ②	UJ534G		U-Joint (Frt. Shaft; Rr.) ②	UJ534G
	<i>Brute Force Greaseable</i>	UJ235		<i>Brute Force Greaseable</i>	UJ235
	<i>Brute Force Non Greaseable</i>	UJ234		<i>Brute Force Non Greaseable</i>	UJ234
	Clamp Kit (Frt. Shaft; Rr.)	UJ530-10		Clamp Kit (Frt. Shaft; Rr.)	UJ530-10
	U-Joint (Rr. Shaft; Frt.) ③	UJ330		U-Joint (Rr. Shaft; Frt.) ③	UJ330
	<i>Brute Force Greaseable</i>	UJ295		<i>Brute Force Greaseable</i>	UJ295
	(For Aluminum Drive Shaft)	UJ330C		(For Aluminum Drive Shaft)	UJ330C
	Clamp Kit (Rr. Shaft; Frt.)	UJ492-10		Clamp Kit (Rr. Shaft; Frt.)	UJ492-10
	U-Joint (Rr. Shaft; Rr.) ④	UJ330		U-Joint (Rr. Shaft; Rr.) ④	UJ330
	<i>Brute Force Greaseable</i>	UJ295		<i>Brute Force Greaseable</i>	UJ295
	(For Aluminum Drive Shaft)	UJ330C		(For Aluminum Drive Shaft)	UJ330C
	Clamp Kit (Rr. Shaft; Rr.)	UJ492-10		Clamp Kit (Rr. Shaft; Rr.)	UJ492-10
2006-2005 Silverado & Sierra w/ Ext. Cab, Std.			2006-2005 Silverado & Sierra w/ Ext. Cab, Long		
Bed & 6 Spd. Man. Trans.: [Type 13]			Bed & 6 Spd. Man. Trans.: [Type 13]		
	U-Joint (Frt. Shaft; Frt.) ①	UJ534G		U-Joint (Frt. Shaft; Frt.) ①	UJ534G
	<i>Brute Force Greaseable</i>	UJ235		<i>Brute Force Greaseable</i>	UJ235
	<i>Brute Force Non Greaseable</i>	UJ234		<i>Brute Force Non Greaseable</i>	UJ234
	Clamp Kit (Frt. Shaft; Frt.)	UJ530-10		Clamp Kit (Frt. Shaft; Frt.)	UJ530-10
	U-Joint (Frt. Shaft; Rr.) ②	UJ534G		U-Joint (Frt. Shaft; Rr.) ②	UJ534G
	<i>Brute Force Greaseable</i>	UJ235		<i>Brute Force Greaseable</i>	UJ235
	<i>Brute Force Non Greaseable</i>	UJ234		<i>Brute Force Non Greaseable</i>	UJ234
	Clamp Kit (Frt. Shaft; Rr.)	UJ530-10		Clamp Kit (Frt. Shaft; Rr.)	UJ530-10
	U-Joint (Rr. Shaft; Frt.) ③	UJ351		U-Joint (Rr. Shaft; Frt.) ③	UJ351
	(For Aluminum Drive Shaft)	UJ351C		(For Aluminum Drive Shaft)	UJ351C
	<i>Brute Force Non Greaseable</i>	UJ351BF		<i>Brute Force Non Greaseable</i>	UJ351BF
	U-Joint (Rr. Shaft; Rr.) ④	UJ351		U-Joint (Rr. Shaft; Rr.) ④	UJ351
	(For Aluminum Drive Shaft)	UJ351C		(For Aluminum Drive Shaft)	UJ351C
	<i>Brute Force Non Greaseable</i>	UJ351BF		<i>Brute Force Non Greaseable</i>	UJ351BF
2006-2005 Silverado & Sierra w/ Ext. Cab, Long			2006-2005 Silverado & Sierra w/ Ext. Cab, Long		
Bed & Auto. Trans.: [Type 13]			Bed & Auto. Trans.: [Type 13]		
	U-Joint (Frt. Shaft; Frt.) ①	UJ534G		U-Joint (Frt. Shaft; Frt.) ①	UJ534G
	<i>Brute Force Greaseable</i>	UJ235		<i>Brute Force Greaseable</i>	UJ235
	<i>Brute Force Non Greaseable</i>	UJ234		<i>Brute Force Non Greaseable</i>	UJ234
	Clamp Kit (Frt. Shaft; Frt.)	UJ530-10		Clamp Kit (Frt. Shaft; Frt.)	UJ530-10
	U-Joint (Frt. Shaft; Rr.) ②	UJ534G		U-Joint (Frt. Shaft; Rr.) ②	UJ534G
	<i>Brute Force Greaseable</i>	UJ235		<i>Brute Force Greaseable</i>	UJ235
	<i>Brute Force Non Greaseable</i>	UJ234		<i>Brute Force Non Greaseable</i>	UJ234
	Clamp Kit (Frt. Shaft; Rr.)	UJ530-10		Clamp Kit (Frt. Shaft; Rr.)	UJ530-10
	U-Joint (Rr. Shaft; Frt.) ③	UJ330		U-Joint (Rr. Shaft; Frt.) ③	UJ330
	<i>Brute Force Greaseable</i>	UJ295		<i>Brute Force Greaseable</i>	UJ295
	(For Aluminum Drive Shaft)	UJ330C		(For Aluminum Drive Shaft)	UJ330C
	Clamp Kit (Rr. Shaft; Frt.)	UJ492-10		Clamp Kit (Rr. Shaft; Frt.)	UJ492-10
	U-Joint (Rr. Shaft; Rr.) ④	UJ330		U-Joint (Rr. Shaft; Rr.) ④	UJ330
	<i>Brute Force Greaseable</i>	UJ295		<i>Brute Force Greaseable</i>	UJ295
	(For Aluminum Drive Shaft)	UJ330C		(For Aluminum Drive Shaft)	UJ330C
	Clamp Kit (Rr. Shaft; Rr.)	UJ492-10		Clamp Kit (Rr. Shaft; Rr.)	UJ492-10

(Continued)

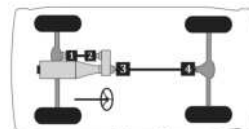

Type 13

Passenger cars, light & medium trucks

Chevrolet/GMC Truck 3/4 ton -- (Cont.)

MFG./YEAR	MODEL & LOCATION	PART NO.	MFG./YEAR	MODEL & LOCATION	PART NO.
-----------	------------------	----------	-----------	------------------	----------

Drive Shaft (4 W/D) (Cont.)

U-Joint (Cont.)

2006-2005 Silverado & Sierra w/ Crew Cab, Std.

Bed & Auto. Trans.: [Type 13]

U-Joint (Fr. Shaft; Frt.)⊙	UJ534G
Brute Force Greaseable	UJ235
Brute Force Non Greaseable	UJ234
Clamp Kit (Fr. Shaft; Frt.)	UJ530-10
U-Joint (Fr. Shaft; Rr.)⊙	UJ330
Brute Force Greaseable	UJ295
(For Aluminum Drive Shaft)	UJ330C
Clamp Kit (Fr. Shaft; Rr.)	UJ492-10
U-Joint (Rr. Shaft; Frt.)⊙	UJ330
Brute Force Greaseable	UJ295
(For Aluminum Drive Shaft)	UJ330C
Clamp Kit (Rr. Shaft; Frt.)	UJ492-10
U-Joint (Rr. Shaft; Rr.)⊙	UJ330
Brute Force Greaseable	UJ295
(For Aluminum Drive Shaft)	UJ330C
Clamp Kit (Rr. Shaft; Rr.)	UJ492-10

2006-2005 Silverado & Sierra w/ Crew Cab, Long

Bed & Auto Trans.: [Type 14]

U-Joint (Fr. Shaft; Frt.)⊙	UJ534G
Brute Force Greaseable	UJ235
Brute Force Non Greaseable	UJ234
Clamp Kit (Fr. Shaft; Frt.)	UJ530-10
U-Joint (Fr. Shaft; Rr.)⊙	UJ534G
Brute Force Greaseable	UJ235
Brute Force Non Greaseable	UJ234
Clamp Kit (Fr. Shaft; Rr.)	UJ530-10
U-Joint (Rr. Shaft; Frt.)⊙	UJ330
Brute Force Greaseable	UJ295
(For Aluminum Drive Shaft)	UJ330C
Clamp Kit (Rr. Shaft; Frt.)	UJ492-10
U-Joint (Rr. Shaft; Ctr.)⊙	UJ330
Brute Force Greaseable	UJ295
(For Aluminum Drive Shaft)	UJ330C
Clamp Kit (Rr. Shaft; Ctr.)	UJ492-10
U-Joint (Rr. Shaft; Rr.)⊙	UJ330
Brute Force Greaseable	UJ295
(For Aluminum Drive Shaft)	UJ330C
Clamp Kit (Rr. Shaft; Rr.)	UJ492-10

Drive Shaft (4 W/D) (Cont.)

U-Joint (Cont.)

2006-2005 Silverado & Sierra w/ Crew Cab & 5

Spd. Man. Trans.: [Type 14]

U-Joint (Fr. Shaft; Frt.)⊙	UJ534G
Brute Force Greaseable	UJ235
Brute Force Non Greaseable	UJ234
Clamp Kit (Fr. Shaft; Frt.)	UJ530-10
U-Joint (Fr. Shaft; Rr.)⊙	UJ534G
Brute Force Greaseable	UJ235
Brute Force Non Greaseable	UJ234
Clamp Kit (Fr. Shaft; Rr.)	UJ530-10
U-Joint (Rr. Shaft; Frt.)⊙	UJ330
Brute Force Greaseable	UJ295
(For Aluminum Drive Shaft)	UJ330C
Clamp Kit (Rr. Shaft; Frt.)	UJ492-10
U-Joint (Rr. Shaft; Ctr.)⊙	UJ330
Brute Force Greaseable	UJ295
(For Aluminum Drive Shaft)	UJ330C
Clamp Kit (Rr. Shaft; Ctr.)	UJ492-10
U-Joint (Rr. Shaft; Rr.)⊙	UJ330
Brute Force Greaseable	UJ295
(For Aluminum Drive Shaft)	UJ330C
Clamp Kit (Rr. Shaft; Rr.)	UJ492-10

2006-2005 Silverado & Sierra w/ Crew Cab & 6

Spd. Man. Trans.: [Type 14]

U-Joint (Fr. Shaft; Frt.)⊙	UJ534G
Brute Force Greaseable	UJ235
Brute Force Non Greaseable	UJ234
Clamp Kit (Fr. Shaft; Frt.)	UJ530-10
U-Joint (Fr. Shaft; Rr.)⊙	UJ534G
Brute Force Greaseable	UJ235
Brute Force Non Greaseable	UJ234
Clamp Kit (Fr. Shaft; Rr.)	UJ530-10
U-Joint (Rr. Shaft; Frt.)⊙	UJ351
(For Aluminum Drive Shaft)	UJ351C
Brute Force Non Greaseable	UJ351BF
U-Joint (Rr. Shaft; Ctr.)⊙	UJ351
(For Aluminum Drive Shaft)	UJ351C
Brute Force Non Greaseable	UJ351BF
U-Joint (Rr. Shaft; Rr.)⊙	UJ351
(For Aluminum Drive Shaft)	UJ351C
Brute Force Non Greaseable	UJ351BF

(Continued)

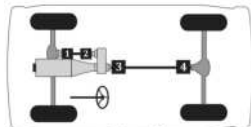

Type 13

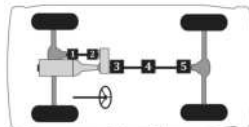

Type 14

Passenger cars, light & medium trucks

(Cont.) -- Chevrolet/GMC Truck 3/4 ton

MFG./YEAR	MODEL & LOCATION	PART NO.	MFG./YEAR	MODEL & LOCATION	PART NO.
Drive Shaft (4 W/D) (Cont.)			Drive Shaft (4 W/D) (Cont.)		
U-Joint (Cont.)			U-Joint (Cont.)		
2006-2001 Avalanche, Suburban & Yukon XL w/ 8.1L Eng.: [Type 13]			2004 Silverado & Sierra w/ Reg. Cab Exc. HD: [Type 13]		
U-Joint (Frt. Shaft; Frt.) ①		UJ534G	U-Joint (Frt. Shaft; Frt.) ①		UJ534G
<i>Brute Force Greaseable</i>		UJ235	<i>Brute Force Greaseable</i>		UJ235
<i>Brute Force Non Greaseable</i>		UJ234	<i>Brute Force Non Greaseable</i>		UJ234
Clamp Kit (Frt. Shaft; Frt.)		UJ530-10	Clamp Kit (Frt. Shaft; Frt.)		UJ530-10
U-Joint (Frt. Shaft; Rr.) ②		UJ534G	U-Joint (Frt. Shaft; Rr.) ②		UJ534G
<i>Brute Force Greaseable</i>		UJ235	<i>Brute Force Greaseable</i>		UJ235
<i>Brute Force Non Greaseable</i>		UJ234	<i>Brute Force Non Greaseable</i>		UJ234
Clamp Kit (Frt. Shaft; Rr.)		UJ530-10	Clamp Kit (Frt. Shaft; Rr.)		UJ530-10
U-Joint (Rr. Shaft; Frt.) ③		UJ330	U-Joint (Rr. Shaft; Frt.) ③		UJ331
<i>Brute Force Greaseable</i>		UJ295	<i>Brute Force Greaseable</i>		UJ232
(For Aluminum Drive Shaft)		UJ330C	<i>Brute Force Non Greaseable</i>		UJ231
Clamp Kit (Rr. Shaft; Frt.)		UJ492-10	(For Aluminum Drive Shaft)		UJ331C
U-Joint (Rr. Shaft; Rr.) ④		UJ330	Clamp Kit (Rr. Shaft; Frt.)		UJ492-10
<i>Brute Force Greaseable</i>		UJ295	U-Joint (Rr. Shaft; Rr.) ④		UJ331
(For Aluminum Drive Shaft)		UJ330C	<i>Brute Force Greaseable</i>		UJ232
Clamp Kit (Rr. Shaft; Rr.)		UJ492-10	<i>Brute Force Non Greaseable</i>		UJ231
2006-2000 Suburban & Yukon XL w/ 6.0L Eng.: [Type 13]			(For Aluminum Drive Shaft)		UJ331C
U-Joint (Frt. Shaft; Frt.) ①		UJ534G	Clamp Kit (Rr. Shaft; Rr.)		UJ492-10
<i>Brute Force Greaseable</i>		UJ235	2004 Silverado & Sierra w/ Ext. Cab Exc. HD: [Type 13]		
<i>Brute Force Non Greaseable</i>		UJ234	U-Joint (Frt. Shaft; Frt.) ①		UJ534G
Clamp Kit (Frt. Shaft; Frt.)		UJ530-10	<i>Brute Force Greaseable</i>		UJ235
U-Joint (Frt. Shaft; Rr.) ②		UJ534G	<i>Brute Force Non Greaseable</i>		UJ234
<i>Brute Force Greaseable</i>		UJ235	Clamp Kit (Frt. Shaft; Frt.)		UJ530-10
<i>Brute Force Non Greaseable</i>		UJ234	U-Joint (Frt. Shaft; Rr.) ②		UJ534G
Clamp Kit (Frt. Shaft; Rr.)		UJ530-10	<i>Brute Force Greaseable</i>		UJ235
U-Joint (Rr. Shaft; Frt.) ③		UJ331	<i>Brute Force Non Greaseable</i>		UJ234
<i>Brute Force Greaseable</i>		UJ232	Clamp Kit (Frt. Shaft; Rr.)		UJ530-10
<i>Brute Force Non Greaseable</i>		UJ231	U-Joint (Rr. Shaft; Frt.) ③		UJ331
(For Aluminum Drive Shaft)		UJ331C	<i>Brute Force Greaseable</i>		UJ232
Clamp Kit (Rr. Shaft; Frt.)		UJ492-10	<i>Brute Force Non Greaseable</i>		UJ231
U-Joint (Rr. Shaft; Rr.) ④		UJ331	(For Aluminum Drive Shaft)		UJ331C
<i>Brute Force Greaseable</i>		UJ232	Clamp Kit (Rr. Shaft; Frt.)		UJ492-10
<i>Brute Force Non Greaseable</i>		UJ231	U-Joint (Rr. Shaft; Rr.) ④		UJ331
(For Aluminum Drive Shaft)		UJ331C	<i>Brute Force Greaseable</i>		UJ232
Clamp Kit (Rr. Shaft; Rr.)		UJ492-10	<i>Brute Force Non Greaseable</i>		UJ231
			(For Aluminum Drive Shaft)		UJ331C
			Clamp Kit (Rr. Shaft; Rr.)		UJ492-10

(Continued)

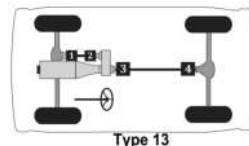

Passenger cars, light & medium trucks

Chevrolet/GMC Truck 3/4 ton -- (Cont.)

MFG./YEAR	MODEL & LOCATION	PART NO.	MFG./YEAR	MODEL & LOCATION	PART NO.
-----------	------------------	----------	-----------	------------------	----------

Drive Shaft (4 W/D) (Cont.)

U-Joint (Cont.)

2004	Silverado & Sierra w/ Crew Cab Exc.	
	HD: [Type 14]	
U-Joint (Fr. Shaft; Frt.)⊙	UJ534G
Brute Force Greaseable	UJ235
Brute Force Non Greaseable	UJ234
Clamp Kit (Fr. Shaft; Frt.)	UJ530-10
U-Joint (Fr. Shaft; Rr.)⊙	UJ534G
Brute Force Greaseable	UJ235
Brute Force Non Greaseable	UJ234
Clamp Kit (Fr. Shaft; Rr.)	UJ530-10
U-Joint (Rr. Shaft; Frt.)⊙	UJ331
Brute Force Greaseable	UJ232
Brute Force Non Greaseable	UJ231
(For Aluminum Drive Shaft)	UJ331C
Clamp Kit (Rr. Shaft; Frt.)	UJ492-10
U-Joint (Rr. Shaft; Ctr.)⊙	UJ331
Brute Force Greaseable	UJ232
Brute Force Non Greaseable	UJ231
(For Aluminum Drive Shaft)	UJ331C
Clamp Kit (Rr. Shaft; Ctr.)	UJ492-10
U-Joint (Rr. Shaft; Rr.)⊙	UJ331
Brute Force Greaseable	UJ232
Brute Force Non Greaseable	UJ231
(For Aluminum Drive Shaft)	UJ331C
Clamp Kit (Rr. Shaft; Rr.)	UJ492-10
2004	Silverado & Sierra HD w/ Reg. Cab & 4	
	Spd. Auto. Trans.: [Type 13]	
U-Joint (Fr. Shaft; Frt.)⊙	UJ534G
Brute Force Greaseable	UJ235
Brute Force Non Greaseable	UJ234
Clamp Kit (Fr. Shaft; Frt.)	UJ530-10
U-Joint (Fr. Shaft; Rr.)⊙	UJ534G
Brute Force Greaseable	UJ235
Brute Force Non Greaseable	UJ234
Clamp Kit (Fr. Shaft; Rr.)	UJ530-10
U-Joint (Rr. Shaft; Frt.)⊙	UJ330A
Brute Force Greaseable	UJ295A
Clamp Kit (Rr. Shaft; Frt.)	UJ492-10
U-Joint (Rr. Shaft; Rr.)⊙	UJ330A
Brute Force Greaseable	UJ295A
Clamp Kit (Rr. Shaft; Rr.)	UJ492-10

Drive Shaft (4 W/D) (Cont.)

U-Joint (Cont.)

2004	Silverado & Sierra HD w/ Reg. Cab, 5	
	Spd. Auto. Trans. & 1.188" Dia. Brg.	
	Cap: [Type 13]	
U-Joint (Fr. Shaft; Frt.)⊙	UJ534G
Brute Force Greaseable	UJ235
Brute Force Non Greaseable	UJ234
Clamp Kit (Fr. Shaft; Frt.)	UJ530-10
U-Joint (Fr. Shaft; Rr.)⊙	UJ534G
Brute Force Greaseable	UJ235
Brute Force Non Greaseable	UJ234
Clamp Kit (Fr. Shaft; Rr.)	UJ530-10
U-Joint (Rr. Shaft; Frt.)⊙	UJ330
Brute Force Greaseable	UJ295
(For Aluminum Drive Shaft)	UJ330C
Clamp Kit (Rr. Shaft; Frt.)	UJ492-10
U-Joint (Rr. Shaft; Rr.)⊙	UJ330
Brute Force Greaseable	UJ295
(For Aluminum Drive Shaft)	UJ330C
Clamp Kit (Rr. Shaft; Rr.)	UJ492-10
2004	Silverado & Sierra HD w/ Reg. Cab, 5	
	Spd. Auto. Trans. & 1.375" Dia. Brg.	
	Cap: [Type 13]	
U-Joint (Fr. Shaft; Frt.)⊙	UJ534G
Brute Force Greaseable	UJ235
Brute Force Non Greaseable	UJ234
Clamp Kit (Fr. Shaft; Frt.)	UJ530-10
U-Joint (Fr. Shaft; Rr.)⊙	UJ534G
Brute Force Greaseable	UJ235
Brute Force Non Greaseable	UJ234
Clamp Kit (Fr. Shaft; Rr.)	UJ530-10
U-Joint (Rr. Shaft; Frt.)⊙	UJ351
(For Aluminum Drive Shaft)	UJ351C
Brute Force Non Greaseable	UJ351BF
U-Joint (Rr. Shaft; Rr.)⊙	UJ351
(For Aluminum Drive Shaft)	UJ351C
Brute Force Non Greaseable	UJ351BF

(Continued)

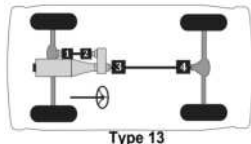

Type 13

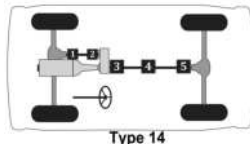

Type 14



Passenger cars, light & medium trucks

(Cont.) -- Chevrolet/GMC Truck 3/4 ton

MFG./YEAR	MODEL & LOCATION	PART NO.	MFG./YEAR	MODEL & LOCATION	PART NO.
Drive Shaft (4 W/D) (Cont.)			Drive Shaft (4 W/D) (Cont.)		
U-Joint (Cont.)			U-Joint (Cont.)		
2004	Silverado & Sierra HD w/ Reg. Cab & 5 Spd. Man. Trans.: [Type 13]		2004	Silverado & Sierra HD w/ Ext. Cab, 5 Spd. Auto. Trans. & 1.375" Dia. Brg. Cap: [Type 13]	
	U-Joint (Frnt. Shaft; Frnt.)Ⓚ	UJ534G		U-Joint (Frnt. Shaft; Frnt.)Ⓚ	UJ534G
	Brute Force Greaseable	UJ235		Brute Force Greaseable	UJ235
	Brute Force Non Greaseable	UJ234		Brute Force Non Greaseable	UJ234
	Clamp Kit (Frnt. Shaft; Frnt.)	UJ530-10		Clamp Kit (Frnt. Shaft; Frnt.)	UJ530-10
	U-Joint (Frnt. Shaft; Rr.)Ⓚ	UJ534G		U-Joint (Frnt. Shaft; Rr.)Ⓚ	UJ534G
	Brute Force Greaseable	UJ235		Brute Force Greaseable	UJ235
	Brute Force Non Greaseable	UJ234		Brute Force Non Greaseable	UJ234
	Clamp Kit (Frnt. Shaft; Rr.)	UJ530-10		Clamp Kit (Frnt. Shaft; Rr.)	UJ530-10
	U-Joint (Rr. Shaft; Frnt.)Ⓚ	UJ330A		U-Joint (Rr. Shaft; Frnt.)Ⓚ	UJ351
	Brute Force Greaseable	UJ295A		(For Aluminum Drive Shaft)	UJ351C
	Clamp Kit (Rr. Shaft; Frnt.)	UJ492-10		Brute Force Non Greaseable	UJ351BF
	U-Joint (Rr. Shaft; Rr.)Ⓚ	UJ330A		U-Joint (Rr. Shaft; Rr.)Ⓚ	UJ351
	Brute Force Greaseable	UJ295A		(For Aluminum Drive Shaft)	UJ351C
	Clamp Kit (Rr. Shaft; Rr.)	UJ492-10		Brute Force Non Greaseable	UJ351BF
2004	Silverado & Sierra HD w/ Reg. Cab & 6 Spd. Man. Trans.: [Type 13]		2004	Silverado & Sierra HD w/ Ext. Cab, Std. Bed & 5 Spd. Man. Trans.: [Type 13]	
	U-Joint (Frnt. Shaft; Frnt.)Ⓚ	UJ534G		U-Joint (Frnt. Shaft; Frnt.)Ⓚ	UJ534G
	Brute Force Greaseable	UJ235		Brute Force Greaseable	UJ235
	Brute Force Non Greaseable	UJ234		Brute Force Non Greaseable	UJ234
	Clamp Kit (Frnt. Shaft; Frnt.)	UJ530-10		Clamp Kit (Frnt. Shaft; Frnt.)	UJ530-10
	U-Joint (Frnt. Shaft; Rr.)Ⓚ	UJ534G		U-Joint (Frnt. Shaft; Rr.)Ⓚ	UJ534G
	Brute Force Greaseable	UJ235		Brute Force Greaseable	UJ235
	Brute Force Non Greaseable	UJ234		Brute Force Non Greaseable	UJ234
	Clamp Kit (Frnt. Shaft; Rr.)	UJ530-10		Clamp Kit (Frnt. Shaft; Rr.)	UJ530-10
	U-Joint (Rr. Shaft; Frnt.)Ⓚ	UJ351		U-Joint (Rr. Shaft; Frnt.)Ⓚ	UJ330
	(For Aluminum Drive Shaft)	UJ351C		Brute Force Greaseable	UJ295
	Brute Force Non Greaseable	UJ351BF		(For Aluminum Drive Shaft)	UJ330C
	U-Joint (Rr. Shaft; Rr.)Ⓚ	UJ351		Clamp Kit (Rr. Shaft; Frnt.)	UJ492-10
	(For Aluminum Drive Shaft)	UJ351C		U-Joint (Rr. Shaft; Rr.)Ⓚ	UJ330
	Brute Force Non Greaseable	UJ351BF		Brute Force Greaseable	UJ295
2004	Silverado & Sierra HD w/ Ext. Cab, 4 & 5 Spd. Auto. Trans. & 1.188" Dia. Brg. Cap: [Type 13]			(For Aluminum Drive Shaft)	UJ330C
	U-Joint (Frnt. Shaft; Frnt.)Ⓚ	UJ534G		Clamp Kit (Rr. Shaft; Rr.)	UJ492-10
	Brute Force Greaseable	UJ235			
	Brute Force Non Greaseable	UJ234			
	Clamp Kit (Frnt. Shaft; Frnt.)	UJ530-10			
	U-Joint (Frnt. Shaft; Rr.)Ⓚ	UJ534G			
	Brute Force Greaseable	UJ235			
	Brute Force Non Greaseable	UJ234			
	Clamp Kit (Frnt. Shaft; Rr.)	UJ530-10			
	U-Joint (Rr. Shaft; Frnt.)Ⓚ	UJ330			
	Brute Force Greaseable	UJ295			
	(For Aluminum Drive Shaft)	UJ330C			
	Clamp Kit (Rr. Shaft; Frnt.)	UJ492-10			
	U-Joint (Rr. Shaft; Rr.)Ⓚ	UJ330			
	Brute Force Greaseable	UJ295			
	(For Aluminum Drive Shaft)	UJ330C			
	Clamp Kit (Rr. Shaft; Rr.)	UJ492-10			

(Continued)

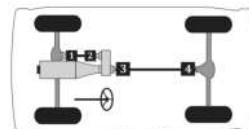

Type 13

Passenger cars, light & medium trucks

Chevrolet/GMC Truck 3/4 ton -- (Cont.)

MFG./YEAR	MODEL & LOCATION	PART NO.	MFG./YEAR	MODEL & LOCATION	PART NO.
Drive Shaft (4 W/D) (Cont.)			Drive Shaft (4 W/D) (Cont.)		
U-Joint (Cont.)			U-Joint (Cont.)		
2004	Silverado & Sierra HD w/ Ext. Cab, Long Bed & 5 Spd. Man. Trans.: [Type 14]		2004	Silverado & Sierra HD w/ Ext. Cab, Long Bed & 6 Spd. Man. Trans.: [Type 14]	
	U-Joint (Fr. Shaft; Frt.) ⓐ	UJ534G		U-Joint (Fr. Shaft; Frt.) ⓐ	UJ534G
	<i>Brute Force Greaseable</i>	UJ235		<i>Brute Force Greaseable</i>	UJ235
	<i>Brute Force Non Greaseable</i>	UJ234		<i>Brute Force Non Greaseable</i>	UJ234
	Clamp Kit (Fr. Shaft; Frt.)	UJ530-10		Clamp Kit (Fr. Shaft; Frt.)	UJ530-10
	U-Joint (Fr. Shaft; Rr.) ⓐ	UJ534G		U-Joint (Fr. Shaft; Rr.) ⓐ	UJ534G
	<i>Brute Force Greaseable</i>	UJ235		<i>Brute Force Greaseable</i>	UJ235
	<i>Brute Force Non Greaseable</i>	UJ234		<i>Brute Force Non Greaseable</i>	UJ234
	Clamp Kit (Fr. Shaft; Rr.)	UJ530-10		Clamp Kit (Fr. Shaft; Rr.)	UJ530-10
	U-Joint (Rr. Shaft; Frt.) ⓐ	UJ330		U-Joint (Rr. Shaft; Frt.) ⓐ	UJ351
	<i>Brute Force Greaseable</i>	UJ295		<i>Brute Force Greaseable</i>	UJ351C
	(For Aluminum Drive Shaft)	UJ330C		(For Aluminum Drive Shaft)	UJ351C
	Clamp Kit (Rr. Shaft; Frt.)	UJ492-10		U-Joint (Rr. Shaft; Ctr.) ⓐ	UJ351
	U-Joint (Rr. Shaft; Ctr.) ⓐ	UJ330		(For Aluminum Drive Shaft)	UJ351C
	<i>Brute Force Greaseable</i>	UJ295		<i>Brute Force Non Greaseable</i>	UJ351BF
	(For Aluminum Drive Shaft)	UJ330C		U-Joint (Rr. Shaft; Rr.) ⓐ	UJ351
	Clamp Kit (Rr. Shaft; Ctr.)	UJ492-10		(For Aluminum Drive Shaft)	UJ351C
	U-Joint (Rr. Shaft; Rr.) ⓐ	UJ330		<i>Brute Force Non Greaseable</i>	UJ351BF
	<i>Brute Force Greaseable</i>	UJ295			
	(For Aluminum Drive Shaft)	UJ330C		2004	Silverado & Sierra HD w/ Crew Cab, Std. Bed & Auto. Trans.: [Type 13]
	Clamp Kit (Rr. Shaft; Rr.)	UJ492-10			
2004	Silverado & Sierra w/ Ext. Cab, Std. Bed & 6 Spd. Man. Trans.: [Type 13]			U-Joint (Fr. Shaft; Frt.) ⓐ	UJ534G
	U-Joint (Fr. Shaft; Frt.) ⓐ	UJ534G		<i>Brute Force Greaseable</i>	UJ235
	<i>Brute Force Greaseable</i>	UJ235		<i>Brute Force Non Greaseable</i>	UJ234
	<i>Brute Force Non Greaseable</i>	UJ234		Clamp Kit (Fr. Shaft; Frt.)	UJ530-10
	Clamp Kit (Fr. Shaft; Frt.)	UJ530-10		U-Joint (Fr. Shaft; Rr.) ⓐ	UJ534G
	U-Joint (Fr. Shaft; Rr.) ⓐ	UJ534G		<i>Brute Force Greaseable</i>	UJ235
	<i>Brute Force Greaseable</i>	UJ235		<i>Brute Force Non Greaseable</i>	UJ234
	<i>Brute Force Non Greaseable</i>	UJ234		Clamp Kit (Fr. Shaft; Rr.)	UJ530-10
	Clamp Kit (Fr. Shaft; Rr.)	UJ530-10		U-Joint (Rr. Shaft; Frt.) ⓐ	UJ330
	U-Joint (Rr. Shaft; Frt.) ⓐ	UJ351		<i>Brute Force Greaseable</i>	UJ295
	(For Aluminum Drive Shaft)	UJ351C		(For Aluminum Drive Shaft)	UJ330C
	<i>Brute Force Non Greaseable</i>	UJ351BF		Clamp Kit (Rr. Shaft; Frt.)	UJ492-10
	U-Joint (Rr. Shaft; Rr.) ⓐ	UJ351		U-Joint (Rr. Shaft; Rr.) ⓐ	UJ330
	(For Aluminum Drive Shaft)	UJ351C		<i>Brute Force Greaseable</i>	UJ295
	<i>Brute Force Non Greaseable</i>	UJ351BF		(For Aluminum Drive Shaft)	UJ330C
				Clamp Kit (Rr. Shaft; Rr.)	UJ492-10

(Continued)

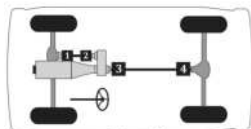

Type 13

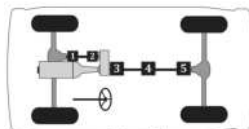

Type 14

Passenger cars, light & medium trucks

(Cont.) -- Chevrolet/GMC Truck 3/4 ton

MFG./YEAR	MODEL & LOCATION	PART NO.	MFG./YEAR	MODEL & LOCATION	PART NO.
Drive Shaft (4 W/D) (Cont.)			Drive Shaft (4 W/D) (Cont.)		
U-Joint (Cont.)			U-Joint (Cont.)		
2004	Silverado & Sierra HD w/ Crew Cab, Long Bed & Auto. Trans.: [Type 14]		2004	Silverado & Sierra HD w/ Crew Cab & 6 Spd. Man. Trans.: [Type 14]	
	U-Joint (Frt. Shaft; Frt.) ①	UJ534G		U-Joint (Frt. Shaft; Frt.) ①	UJ534G
	<i>Brute Force Greaseable</i>	UJ235		<i>Brute Force Greaseable</i>	UJ235
	<i>Brute Force Non Greaseable</i>	UJ234		<i>Brute Force Non Greaseable</i>	UJ234
	Clamp Kit (Frt. Shaft; Frt.)	UJ530-10		Clamp Kit (Frt. Shaft; Frt.)	UJ530-10
	U-Joint (Frt. Shaft; Rr.) ②	UJ534G		U-Joint (Frt. Shaft; Rr.) ②	UJ534G
	<i>Brute Force Greaseable</i>	UJ235		<i>Brute Force Greaseable</i>	UJ235
	<i>Brute Force Non Greaseable</i>	UJ234		<i>Brute Force Non Greaseable</i>	UJ234
	Clamp Kit (Frt. Shaft; Rr.)	UJ530-10		Clamp Kit (Frt. Shaft; Rr.)	UJ530-10
	U-Joint (Rr. Shaft; Frt.) ③	UJ330		U-Joint (Rr. Shaft; Frt.) ③	UJ351
	<i>Brute Force Greaseable</i>	UJ295		(For Aluminum Drive Shaft)	UJ351C
	(For Aluminum Drive Shaft)	UJ330C		<i>Brute Force Non Greaseable</i>	UJ351BF
	Clamp Kit (Rr. Shaft; Frt.)	UJ492-10		U-Joint (Rr. Shaft; Ctr.) ④	UJ351
	U-Joint (Rr. Shaft; Ctr.) ④	UJ330		(For Aluminum Drive Shaft)	UJ351C
	<i>Brute Force Greaseable</i>	UJ295		<i>Brute Force Non Greaseable</i>	UJ351BF
	(For Aluminum Drive Shaft)	UJ330C		2003-2001 Silverado & Sierra Exc. HD: [Type 13]	
	Clamp Kit (Rr. Shaft; Ctr.)	UJ492-10		U-Joint (Frt. Shaft; Frt.) ①	UJ534G
2004	Silverado & Sierra HD w/ Crew Cab & 5 Spd. Man. Trans.: [Type 14]			<i>Brute Force Greaseable</i>	UJ235
	U-Joint (Frt. Shaft; Frt.) ①	UJ534G		<i>Brute Force Non Greaseable</i>	UJ234
	<i>Brute Force Greaseable</i>	UJ235		Clamp Kit (Frt. Shaft; Frt.)	UJ530-10
	<i>Brute Force Non Greaseable</i>	UJ234		U-Joint (Frt. Shaft; Rr.) ②	UJ534G
	Clamp Kit (Frt. Shaft; Frt.)	UJ530-10		<i>Brute Force Greaseable</i>	UJ235
	U-Joint (Frt. Shaft; Rr.) ②	UJ534G		<i>Brute Force Non Greaseable</i>	UJ234
	<i>Brute Force Greaseable</i>	UJ235		Clamp Kit (Frt. Shaft; Rr.)	UJ530-10
	<i>Brute Force Non Greaseable</i>	UJ234		U-Joint (Rr. Shaft; Frt.) ③	UJ331
	Clamp Kit (Frt. Shaft; Rr.)	UJ530-10		<i>Brute Force Greaseable</i>	UJ232
	U-Joint (Rr. Shaft; Frt.) ③	UJ330		<i>Brute Force Non Greaseable</i>	UJ231
	<i>Brute Force Greaseable</i>	UJ295		(For Aluminum Drive Shaft)	UJ331C
	(For Aluminum Drive Shaft)	UJ330C		Clamp Kit (Rr. Shaft; Frt.)	UJ492-10
	Clamp Kit (Rr. Shaft; Frt.)	UJ492-10		U-Joint (Rr. Shaft; Rr.) ④	UJ331
	U-Joint (Rr. Shaft; Ctr.) ④	UJ330		<i>Brute Force Greaseable</i>	UJ232
	<i>Brute Force Greaseable</i>	UJ295		<i>Brute Force Non Greaseable</i>	UJ231
	(For Aluminum Drive Shaft)	UJ330C		(For Aluminum Drive Shaft)	UJ331C
	Clamp Kit (Rr. Shaft; Ctr.)	UJ492-10		Clamp Kit (Rr. Shaft; Rr.)	UJ492-10
	U-Joint (Rr. Shaft; Rr.) ⑤	UJ330			(Continued)
	<i>Brute Force Greaseable</i>	UJ295			
	(For Aluminum Drive Shaft)	UJ330C			
	Clamp Kit (Rr. Shaft; Rr.)	UJ492-10			

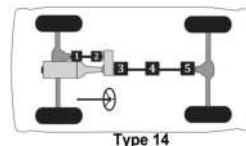
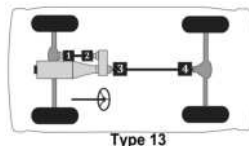

Passenger cars, light & medium trucks

Chevrolet/GMC Truck 3/4 ton -- (Cont.)

MFG./YEAR	MODEL & LOCATION	PART NO.	MFG./YEAR	MODEL & LOCATION	PART NO.
Drive Shaft (4 W/D) (Cont.)			Drive Shaft (4 W/D) (Cont.)		
U-Joint (Cont.)			U-Joint (Cont.)		
2003-2001 Silverado & Sierra HD w/ Reg. Cab & 4 Spd. Auto. Trans.: [Type 13]			2003-2001 Silverado & Sierra HD w/ Reg. Cab & 6 Spd. Man. Trans.: [Type 13]		
U-Joint (Fr. Shaft; Frt.)		UJ534G	U-Joint (Fr. Shaft; Frt.)		UJ534G
Brute Force Greaseable		UJ235	Brute Force Greaseable		UJ235
Brute Force Non Greaseable		UJ234	Brute Force Non Greaseable		UJ234
Clamp Kit (Fr. Shaft; Frt.)		UJ530-10	Clamp Kit (Fr. Shaft; Frt.)		UJ530-10
U-Joint (Fr. Shaft; Rr.)		UJ534G	U-Joint (Fr. Shaft; Rr.)		UJ534G
Brute Force Greaseable		UJ235	Brute Force Greaseable		UJ235
Brute Force Non Greaseable		UJ234	Brute Force Non Greaseable		UJ234
Clamp Kit (Fr. Shaft; Rr.)		UJ530-10	Clamp Kit (Fr. Shaft; Rr.)		UJ530-10
U-Joint (Rr. Shaft; Frt.)		UJ330A	U-Joint (Rr. Shaft; Frt.)		UJ351
Brute Force Greaseable		UJ295A	(For Aluminum Drive Shaft)		UJ351C
Clamp Kit (Rr. Shaft; Frt.)		UJ492-10	Brute Force Non Greaseable		UJ351BF
U-Joint (Rr. Shaft; Rr.)		UJ330A	U-Joint (Rr. Shaft; Rr.)		UJ351
Brute Force Greaseable		UJ295A	(For Aluminum Drive Shaft)		UJ351C
Clamp Kit (Rr. Shaft; Rr.)		UJ492-10	Brute Force Non Greaseable		UJ351BF
2003-2001 Silverado & Sierra HD w/ Reg. Cab & 5 Spd. Auto. Trans.: [Type 13]			2003-2001 Silverado & Sierra HD w/ Ext. Cab & Auto. Trans.: [Type 13]		
U-Joint (Fr. Shaft; Frt.)		UJ534G	U-Joint (Fr. Shaft; Frt.)		UJ534G
Brute Force Greaseable		UJ235	Brute Force Greaseable		UJ235
Brute Force Non Greaseable		UJ234	Brute Force Non Greaseable		UJ234
Clamp Kit (Fr. Shaft; Frt.)		UJ530-10	Clamp Kit (Fr. Shaft; Frt.)		UJ530-10
U-Joint (Fr. Shaft; Rr.)		UJ534G	U-Joint (Fr. Shaft; Rr.)		UJ534G
Brute Force Greaseable		UJ235	Brute Force Greaseable		UJ235
Brute Force Non Greaseable		UJ234	Brute Force Non Greaseable		UJ234
Clamp Kit (Fr. Shaft; Rr.)		UJ530-10	Clamp Kit (Fr. Shaft; Rr.)		UJ530-10
U-Joint (Rr. Shaft; Frt.)		UJ330	U-Joint (Rr. Shaft; Frt.)		UJ330
Brute Force Greaseable		UJ295	Brute Force Greaseable		UJ295
(For Aluminum Drive Shaft)		UJ330C	(For Aluminum Drive Shaft)		UJ330C
Clamp Kit (Rr. Shaft; Frt.)		UJ492-10	Clamp Kit (Rr. Shaft; Frt.)		UJ492-10
U-Joint (Rr. Shaft; Rr.)		UJ330	U-Joint (Rr. Shaft; Rr.)		UJ330
Brute Force Greaseable		UJ295	Brute Force Greaseable		UJ295
(For Aluminum Drive Shaft)		UJ330C	(For Aluminum Drive Shaft)		UJ330C
Clamp Kit (Rr. Shaft; Rr.)		UJ492-10	Clamp Kit (Rr. Shaft; Rr.)		UJ492-10
2003-2001 Silverado & Sierra HD w/ Reg. Cab & 5 Spd. Man. Trans.: [Type 13]			(Continued)		
U-Joint (Fr. Shaft; Frt.)		UJ534G			
Brute Force Greaseable		UJ235			
Brute Force Non Greaseable		UJ234			
Clamp Kit (Fr. Shaft; Frt.)		UJ530-10			
U-Joint (Fr. Shaft; Rr.)		UJ534G			
Brute Force Greaseable		UJ235			
Brute Force Non Greaseable		UJ234			
Clamp Kit (Fr. Shaft; Rr.)		UJ530-10			
U-Joint (Rr. Shaft; Frt.)		UJ330A			
Brute Force Greaseable		UJ295A			
Clamp Kit (Rr. Shaft; Frt.)		UJ492-10			
U-Joint (Rr. Shaft; Rr.)		UJ330A			
Brute Force Greaseable		UJ295A			
Clamp Kit (Rr. Shaft; Rr.)		UJ492-10			

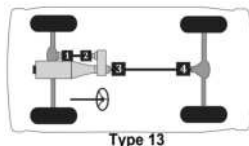

Passenger cars, light & medium trucks

(Cont.) -- Chevrolet/GMC Truck 3/4 ton

MFG./YEAR	MODEL & LOCATION	PART NO.	MFG./YEAR	MODEL & LOCATION	PART NO.
Drive Shaft (4 W/D) (Cont.)			Drive Shaft (4 W/D) (Cont.)		
U-Joint (Cont.)			U-Joint (Cont.)		
2003-2001 Silverado & Sierra HD w/ Ext. Cab, Std. Bed & 5 Spd. Man. Trans.: [Type 13]			2003-2001 Silverado & Sierra HD w/ Ext. Cab, Std. Bed & 6 Spd. Man. Trans.: [Type 13]		
	U-Joint (Frnt. Shaft; Frnt.) ①	UJ534G		U-Joint (Frnt. Shaft; Frnt.) ①	UJ534G
	Brute Force Greaseable	UJ235		Brute Force Greaseable	UJ235
	Brute Force Non Greaseable	UJ234		Brute Force Non Greaseable	UJ234
	Clamp Kit (Frnt. Shaft; Frnt.)	UJ530-10		Clamp Kit (Frnt. Shaft; Frnt.)	UJ530-10
	U-Joint (Frnt. Shaft; Rr.) ②	UJ534G		U-Joint (Frnt. Shaft; Rr.) ②	UJ534G
	Brute Force Greaseable	UJ235		Brute Force Greaseable	UJ235
	Brute Force Non Greaseable	UJ234		Brute Force Non Greaseable	UJ234
	Clamp Kit (Frnt. Shaft; Rr.)	UJ530-10		Clamp Kit (Frnt. Shaft; Rr.)	UJ530-10
	U-Joint (Rr. Shaft; Frnt.) ③	UJ330		U-Joint (Rr. Shaft; Frnt.) ③	UJ351
	Brute Force Greaseable	UJ295		(For Aluminum Drive Shaft)	UJ351C
	(For Aluminum Drive Shaft)	UJ330C		Brute Force Non Greaseable	UJ351BF
	Clamp Kit (Rr. Shaft; Frnt.)	UJ492-10		U-Joint (Rr. Shaft; Rr.) ④	UJ351
	U-Joint (Rr. Shaft; Rr.) ④	UJ330		(For Aluminum Drive Shaft)	UJ351C
	Brute Force Greaseable	UJ295		Brute Force Non Greaseable	UJ351BF
	(For Aluminum Drive Shaft)	UJ330C		2003-2001 Silverado & Sierra HD w/ Ext. Cab, Long Bed & 6 Spd. Man. Trans.: [Type 14]	
	Clamp Kit (Rr. Shaft; Rr.)	UJ492-10		U-Joint (Frnt. Shaft; Frnt.) ①	UJ534G
2003-2001 Silverado & Sierra HD w/ Ext. Cab, Long Bed & 5 Spd. Man. Trans.: [Type 14]				Brute Force Greaseable	UJ235
	U-Joint (Frnt. Shaft; Frnt.) ①	UJ534G		Brute Force Non Greaseable	UJ234
	Brute Force Greaseable	UJ235		Clamp Kit (Frnt. Shaft; Frnt.)	UJ530-10
	Brute Force Non Greaseable	UJ234		U-Joint (Frnt. Shaft; Rr.) ②	UJ534G
	Clamp Kit (Frnt. Shaft; Frnt.)	UJ530-10		Brute Force Greaseable	UJ235
	U-Joint (Frnt. Shaft; Rr.) ②	UJ534G		Brute Force Non Greaseable	UJ234
	Brute Force Greaseable	UJ235		Clamp Kit (Frnt. Shaft; Rr.)	UJ530-10
	Brute Force Non Greaseable	UJ234		U-Joint (Rr. Shaft; Frnt.) ③	UJ351
	Clamp Kit (Frnt. Shaft; Rr.)	UJ530-10		(For Aluminum Drive Shaft)	UJ351C
	U-Joint (Rr. Shaft; Frnt.) ③	UJ330		Brute Force Non Greaseable	UJ351BF
	Brute Force Greaseable	UJ295		U-Joint (Rr. Shaft; Ctr.) ④	UJ351
	(For Aluminum Drive Shaft)	UJ330C		(For Aluminum Drive Shaft)	UJ351C
	Clamp Kit (Rr. Shaft; Frnt.)	UJ492-10		Brute Force Non Greaseable	UJ351BF
	U-Joint (Rr. Shaft; Ctr.) ④	UJ330		U-Joint (Rr. Shaft; Rr.) ⑤	UJ351
	Brute Force Greaseable	UJ295		(For Aluminum Drive Shaft)	UJ351C
	(For Aluminum Drive Shaft)	UJ330C		Brute Force Non Greaseable	UJ351BF
	Clamp Kit (Rr. Shaft; Ctr.)	UJ492-10		U-Joint (Rr. Shaft; Rr.) ⑤	UJ351
	U-Joint (Rr. Shaft; Rr.) ⑤	UJ330		(For Aluminum Drive Shaft)	UJ351C
	Brute Force Greaseable	UJ295		Brute Force Non Greaseable	UJ351BF
	(For Aluminum Drive Shaft)	UJ330C			
	Clamp Kit (Rr. Shaft; Rr.)	UJ492-10			

(Continued)

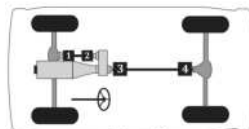

Type 13

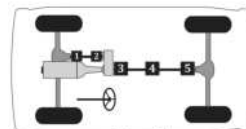

Type 14

Passenger cars, light & medium trucks



Chevrolet/GMC Truck 3/4 ton -- (Cont.)

MFG./YEAR	MODEL & LOCATION	PART NO.	MFG./YEAR	MODEL & LOCATION	PART NO.
-----------	------------------	----------	-----------	------------------	----------





Drive Shaft (4 W/D) (Cont.)

U-Joint (Cont.)

**2003-2001 Silverado & Sierra HD w/ Crew Cab,
Std. Bed & Auto. Trans.: [Type 13]**

U-Joint (Fr. Shaft; Frt.) 	UJ534G
Brute Force Greaseable	UJ235
Brute Force Non Greaseable	UJ234
Clamp Kit (Fr. Shaft; Frt.)	UJ530-10
U-Joint (Fr. Shaft; Rr.) 	UJ534G
Brute Force Greaseable	UJ235
Brute Force Non Greaseable	UJ234
Clamp Kit (Fr. Shaft; Rr.)	UJ530-10
U-Joint (Rr. Shaft; Frt.) 	UJ330
Brute Force Greaseable	UJ295
(For Aluminum Drive Shaft)	UJ330C
Clamp Kit (Rr. Shaft; Frt.)	UJ492-10
U-Joint (Rr. Shaft; Rr.) 	UJ330
Brute Force Greaseable	UJ295
(For Aluminum Drive Shaft)	UJ330C
Clamp Kit (Rr. Shaft; Rr.)	UJ492-10





**2003-2001 Silverado & Sierra HD w/ Crew Cab,
Long Bed & Auto. Trans.: [Type 14]**

U-Joint (Fr. Shaft; Frt.) 	UJ534G
Brute Force Greaseable	UJ235
Brute Force Non Greaseable	UJ234
Clamp Kit (Fr. Shaft; Frt.)	UJ530-10
U-Joint (Fr. Shaft; Rr.) 	UJ534G
Brute Force Greaseable	UJ235
Brute Force Non Greaseable	UJ234
Clamp Kit (Fr. Shaft; Rr.)	UJ530-10
U-Joint (Rr. Shaft; Frt.) 	UJ330
Brute Force Greaseable	UJ295
(For Aluminum Drive Shaft)	UJ330C
Clamp Kit (Rr. Shaft; Frt.)	UJ492-10
U-Joint (Rr. Shaft; Ctr.) 	UJ330
Brute Force Greaseable	UJ295
(For Aluminum Drive Shaft)	UJ330C
Clamp Kit (Rr. Shaft; Ctr.)	UJ492-10
U-Joint (Rr. Shaft; Rr.) 	UJ330
Brute Force Greaseable	UJ295
(For Aluminum Drive Shaft)	UJ330C
Clamp Kit (Rr. Shaft; Rr.)	UJ492-10





Drive Shaft (4 W/D) (Cont.)

U-Joint (Cont.)

**2003-2001 Silverado & Sierra HD w/ Crew Cab &
5 Spd. Man. Trans.: [Type 14]**

U-Joint (Fr. Shaft; Frt.) 	UJ534G
Brute Force Greaseable	UJ235
Brute Force Non Greaseable	UJ234
Clamp Kit (Fr. Shaft; Frt.)	UJ530-10
U-Joint (Fr. Shaft; Rr.) 	UJ534G
Brute Force Greaseable	UJ235
Brute Force Non Greaseable	UJ234
Clamp Kit (Fr. Shaft; Rr.)	UJ530-10
U-Joint (Rr. Shaft; Frt.) 	UJ330
Brute Force Greaseable	UJ295
(For Aluminum Drive Shaft)	UJ330C
Clamp Kit (Rr. Shaft; Frt.)	UJ492-10
U-Joint (Rr. Shaft; Ctr.) 	UJ330
Brute Force Greaseable	UJ295
(For Aluminum Drive Shaft)	UJ330C
Clamp Kit (Rr. Shaft; Ctr.)	UJ492-10
U-Joint (Rr. Shaft; Rr.) 	UJ330
Brute Force Greaseable	UJ295
(For Aluminum Drive Shaft)	UJ330C
Clamp Kit (Rr. Shaft; Rr.)	UJ492-10

**2003-2001 Silverado & Sierra HD w/ Crew Cab &
6 Spd. Man. Trans.: [Type 14]**

U-Joint (Fr. Shaft; Frt.) 	UJ534G
Brute Force Greaseable	UJ235
Brute Force Non Greaseable	UJ234
Clamp Kit (Fr. Shaft; Frt.)	UJ530-10
U-Joint (Fr. Shaft; Rr.) 	UJ534G
Brute Force Greaseable	UJ235
Brute Force Non Greaseable	UJ234
Clamp Kit (Fr. Shaft; Rr.)	UJ530-10
U-Joint (Rr. Shaft; Frt.) 	UJ351
(For Aluminum Drive Shaft)	UJ351C
Brute Force Non Greaseable	UJ351BF
U-Joint (Rr. Shaft; Ctr.) 	UJ351
(For Aluminum Drive Shaft)	UJ351C
Brute Force Non Greaseable	UJ351BF
U-Joint (Rr. Shaft; Rr.) 	UJ351
(For Aluminum Drive Shaft)	UJ351C
Brute Force Non Greaseable	UJ351BF

(Continued)

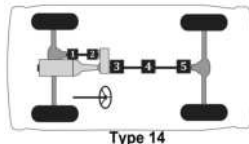
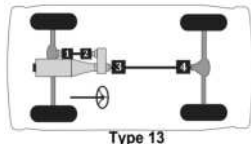

Passenger cars, light & medium trucks

(Cont.) -- Chevrolet/GMC Truck 3/4 ton

MFG./YEAR	MODEL & LOCATION	PART NO.	MFG./YEAR	MODEL & LOCATION	PART NO.
Drive Shaft (4 W/D) (Cont.)			Drive Shaft (4 W/D) (Cont.)		
U-Joint (Cont.)			U-Joint (Cont.)		
2000-1999 Silverado & Sierra w/ Ext. Cab, Long Bed & Auto. Trans.: [Type 14]			2000-1999 Silverado & Sierra w/ Man. Trans.: [Type 13]		
	U-Joint (Frnt. Shaft; Frt.) ①	UJ534G		U-Joint (Frnt. Shaft; Frt.) ①	UJ534G
	<i>Brute Force Greaseable</i>	UJ235		<i>Brute Force Greaseable</i>	UJ235
	<i>Brute Force Non Greaseable</i>	UJ234		<i>Brute Force Non Greaseable</i>	UJ234
	Clamp Kit (Frnt. Shaft; Frt.)	UJ530-10		Clamp Kit (Frnt. Shaft; Frt.)	UJ530-10
	U-Joint (Frnt. Shaft; Rr.) ②	UJ534G		U-Joint (Frnt. Shaft; Rr.) ②	UJ534G
	<i>Brute Force Greaseable</i>	UJ235		<i>Brute Force Greaseable</i>	UJ235
	<i>Brute Force Non Greaseable</i>	UJ234		<i>Brute Force Non Greaseable</i>	UJ234
	Clamp Kit (Frnt. Shaft; Rr.)	UJ530-10		Clamp Kit (Frnt. Shaft; Rr.)	UJ530-10
	U-Joint (Rr. Shaft; Frt.) ③	UJ331		U-Joint (Rr. Shaft; Frt.) ③	UJ330
	<i>Brute Force Greaseable</i>	UJ232		<i>Brute Force Greaseable</i>	UJ295
	<i>Brute Force Non Greaseable</i>	UJ231		(For Aluminum Drive Shaft)	UJ330C
	(For Aluminum Drive Shaft)	UJ331C		Clamp Kit (Rr. Shaft; Frt.)	UJ492-10
	Clamp Kit (Rr. Shaft; Frt.)	UJ492-10		U-Joint (Rr. Shaft; Rr.) ④	UJ330
	U-Joint (Rr. Shaft; Ctr.) ④	UJ331		<i>Brute Force Greaseable</i>	UJ295
	<i>Brute Force Greaseable</i>	UJ232		(For Aluminum Drive Shaft)	UJ330C
	<i>Brute Force Non Greaseable</i>	UJ231		Clamp Kit (Rr. Shaft; Rr.)	UJ492-10
	(For Aluminum Drive Shaft)	UJ331C		2000-1997 K2500 w/ Reg. Cab: [Type 13]	
	Clamp Kit (Rr. Shaft; Ctr.)	UJ492-10		U-Joint (Frnt. Shaft; Frt.) ①	UJ534G
	U-Joint (Rr. Shaft; Rr.) ⑤	UJ331		<i>Brute Force Greaseable</i>	UJ235
	<i>Brute Force Greaseable</i>	UJ232		<i>Brute Force Non Greaseable</i>	UJ234
	<i>Brute Force Non Greaseable</i>	UJ231		Clamp Kit (Frnt. Shaft; Frt.)	UJ530-10
	(For Aluminum Drive Shaft)	UJ331C		U-Joint (Frnt. Shaft; Rr.) ②	UJ534G
	Clamp Kit (Rr. Shaft; Rr.)	UJ492-10		<i>Brute Force Greaseable</i>	UJ235
	2000-1999 Silverado & Sierra w/ Auto. Trans.			<i>Brute Force Non Greaseable</i>	UJ234
	Exc. Ext. Cab & Long Bed: [Type 13]			Clamp Kit (Frnt. Shaft; Rr.)	UJ530-10
	U-Joint (Frnt. Shaft; Frt.) ①	UJ534G		U-Joint (Rr. Shaft; Frt.) ③	UJ331
	<i>Brute Force Greaseable</i>	UJ235		<i>Brute Force Greaseable</i>	UJ232
	<i>Brute Force Non Greaseable</i>	UJ234		<i>Brute Force Non Greaseable</i>	UJ231
	Clamp Kit (Frnt. Shaft; Frt.)	UJ530-10		(For Aluminum Drive Shaft)	UJ331C
	U-Joint (Frnt. Shaft; Rr.) ②	UJ534G		Clamp Kit (Rr. Shaft; Frt.)	UJ492-10
	<i>Brute Force Greaseable</i>	UJ235		U-Joint (Rr. Shaft; Rr.) ④	UJ331
	<i>Brute Force Non Greaseable</i>	UJ234		<i>Brute Force Greaseable</i>	UJ232
	Clamp Kit (Frnt. Shaft; Rr.)	UJ530-10		<i>Brute Force Non Greaseable</i>	UJ231
	U-Joint (Rr. Shaft; Frt.) ③	UJ331		(For Aluminum Drive Shaft)	UJ331C
	<i>Brute Force Greaseable</i>	UJ232		Clamp Kit (Rr. Shaft; Rr.)	UJ492-10
	<i>Brute Force Non Greaseable</i>	UJ231			(Continued)
	(For Aluminum Drive Shaft)	UJ331C			
	Clamp Kit (Rr. Shaft; Frt.)	UJ492-10			
	U-Joint (Rr. Shaft; Rr.) ④	UJ331			
	<i>Brute Force Greaseable</i>	UJ232			
	<i>Brute Force Non Greaseable</i>	UJ231			
	(For Aluminum Drive Shaft)	UJ331C			
	Clamp Kit (Rr. Shaft; Rr.)	UJ492-10			

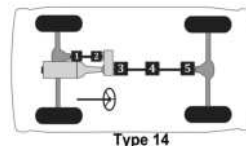
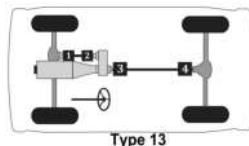

Passenger cars, light & medium trucks

Chevrolet/GMC Truck 3/4 ton -- (Cont.)

MFG./YEAR	MODEL & LOCATION	PART NO.	MFG./YEAR	MODEL & LOCATION	PART NO.
Drive Shaft (4 W/D) (Cont.)			Drive Shaft (4 W/D) (Cont.)		
U-Joint (Cont.)			U-Joint (Cont.)		
2000-1997 K2500 w/ Ext. Cab: [Type 14]			1996-1994 Suburban w/ Gas Eng.: [Type 13]		
	U-Joint (Fr. Shaft; Frt.) [⊙]	UJ534G		U-Joint (Fr. Shaft; Frt.) [⊙]	UJ534G
	Brute Force Greaseable	UJ235		Brute Force Greaseable	UJ235
	Brute Force Non Greaseable	UJ234		Brute Force Non Greaseable	UJ234
	Clamp Kit (Fr. Shaft; Frt.)	UJ530-10		Clamp Kit (Fr. Shaft; Frt.)	UJ530-10
	U-Joint (Fr. Shaft; Rr.) [⊙]	UJ534G		U-Joint (Fr. Shaft; Rr.) [⊙]	UJ534G
	Brute Force Greaseable	UJ235		Brute Force Greaseable	UJ235
	Brute Force Non Greaseable	UJ234		Brute Force Non Greaseable	UJ234
	Clamp Kit (Fr. Shaft; Rr.)	UJ530-10		Clamp Kit (Fr. Shaft; Rr.)	UJ530-10
	U-Joint (Rr. Shaft; Frt.) [⊙]	UJ331		U-Joint (Rr. Shaft; Frt.) [⊙]	UJ331
	Brute Force Greaseable	UJ232		Brute Force Greaseable	UJ232
	Brute Force Non Greaseable	UJ231		Brute Force Non Greaseable	UJ231
	(For Aluminum Drive Shaft)	UJ331C		(For Aluminum Drive Shaft)	UJ331C
	Clamp Kit (Rr. Shaft; Frt.)	UJ492-10		Clamp Kit (Rr. Shaft; Frt.)	UJ492-10
	U-Joint (Rr. Shaft; Ctr.) [⊙]	UJ331		U-Joint (Rr. Shaft; Rr.) [⊙]	UJ331
	Brute Force Greaseable	UJ232		Brute Force Greaseable	UJ232
	Brute Force Non Greaseable	UJ231		Brute Force Non Greaseable	UJ231
	(For Aluminum Drive Shaft)	UJ331C		(For Aluminum Drive Shaft)	UJ331C
	Clamp Kit (Rr. Shaft; Ctr.)	UJ492-10		Clamp Kit (Rr. Shaft; Rr.)	UJ492-10
	U-Joint (Rr. Shaft; Rr.) [⊙]	UJ331		1996-1994 Suburban w/ Diesel Eng.: [Type 13]	
	Brute Force Greaseable	UJ232		U-Joint (Fr. Shaft; Frt.) [⊙]	UJ355
	Brute Force Non Greaseable	UJ231		Brute Force Greaseable	UJ290
	(For Aluminum Drive Shaft)	UJ331C		(For Aluminum Drive Shaft)	UJ355C
	Clamp Kit (Rr. Shaft; Rr.)	UJ492-10		Clamp Kit (Fr. Shaft; Frt.)	UJ530-10
	1999-1997 Suburban: [Type 13]			U-Joint (Fr. Shaft; Rr.) [⊙]	UJ354
	U-Joint (Fr. Shaft; Frt.) [⊙]	UJ534G		Brute Force Greaseable	UJ270
	Brute Force Greaseable	UJ235		Brute Force Non Greaseable	UJ254
	Brute Force Non Greaseable	UJ234		(For Aluminum Drive Shaft)	UJ354C
	Clamp Kit (Fr. Shaft; Frt.)	UJ530-10		U-Joint (Rr. Shaft; Frt.) [⊙]	UJ331
	U-Joint (Fr. Shaft; Rr.) [⊙]	UJ534G		Brute Force Greaseable	UJ232
	Brute Force Greaseable	UJ235		Brute Force Non Greaseable	UJ231
	Brute Force Non Greaseable	UJ234		(For Aluminum Drive Shaft)	UJ331C
	Clamp Kit (Fr. Shaft; Rr.)	UJ530-10		Clamp Kit (Rr. Shaft; Frt.)	UJ492-10
	U-Joint (Rr. Shaft; Frt.) [⊙]	UJ331		U-Joint (Rr. Shaft; Rr.) [⊙]	UJ331
	Brute Force Greaseable	UJ232		Brute Force Greaseable	UJ232
	Brute Force Non Greaseable	UJ231		Brute Force Non Greaseable	UJ231
	(For Aluminum Drive Shaft)	UJ331C		(For Aluminum Drive Shaft)	UJ331C
	Clamp Kit (Rr. Shaft; Frt.)	UJ492-10		Clamp Kit (Rr. Shaft; Rr.)	UJ492-10
	U-Joint (Rr. Shaft; Rr.) [⊙]	UJ331			(Continued)
	Brute Force Greaseable	UJ232			
	Brute Force Non Greaseable	UJ231			
	(For Aluminum Drive Shaft)	UJ331C			
	Clamp Kit (Rr. Shaft; Rr.)	UJ492-10			

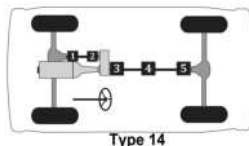
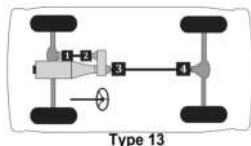

Passenger cars, light & medium trucks

(Cont.) -- Chevrolet/GMC Truck 3/4 ton

MFG./YEAR	MODEL & LOCATION	PART NO.	MFG./YEAR	MODEL & LOCATION	PART NO.
Drive Shaft (4 W/D) (Cont.)			Drive Shaft (4 W/D) (Cont.)		
U-Joint (Cont.)			U-Joint (Cont.)		
1996-1994 K2500 w/ Reg. Cab & Gas Eng.:			1996-1994 K2500 w/ Ext. Cab & Gas Eng.: [Type		
[Type 13]			14]		
U-Joint (Fr. Shaft; Frt.) ①		UJ534G	U-Joint (Fr. Shaft; Frt.) ①		UJ534G
<i>Brute Force Greaseable</i>		UJ235	<i>Brute Force Greaseable</i>		UJ235
<i>Brute Force Non Greaseable</i>		UJ234	<i>Brute Force Non Greaseable</i>		UJ234
Clamp Kit (Fr. Shaft; Frt.)		UJ530-10	Clamp Kit (Fr. Shaft; Frt.)		UJ530-10
U-Joint (Fr. Shaft; Rr.) ②		UJ534G	U-Joint (Fr. Shaft; Rr.) ②		UJ534G
<i>Brute Force Greaseable</i>		UJ235	<i>Brute Force Greaseable</i>		UJ235
<i>Brute Force Non Greaseable</i>		UJ234	<i>Brute Force Non Greaseable</i>		UJ234
Clamp Kit (Fr. Shaft; Rr.)		UJ530-10	Clamp Kit (Fr. Shaft; Rr.)		UJ530-10
U-Joint (Rr. Shaft; Frt.) ③		UJ331	U-Joint (Rr. Shaft; Frt.) ③		UJ331
<i>Brute Force Greaseable</i>		UJ232	<i>Brute Force Greaseable</i>		UJ232
<i>Brute Force Non Greaseable</i>		UJ231	<i>Brute Force Non Greaseable</i>		UJ231
(For Aluminum Drive Shaft)		UJ331C	(For Aluminum Drive Shaft)		UJ331C
Clamp Kit (Rr. Shaft; Frt.)		UJ492-10	Clamp Kit (Rr. Shaft; Frt.)		UJ492-10
U-Joint (Rr. Shaft; Rr.) ④		UJ331	U-Joint (Rr. Shaft; Rr.) ④		UJ331
<i>Brute Force Greaseable</i>		UJ232	<i>Brute Force Greaseable</i>		UJ232
<i>Brute Force Non Greaseable</i>		UJ231	<i>Brute Force Non Greaseable</i>		UJ231
(For Aluminum Drive Shaft)		UJ331C	(For Aluminum Drive Shaft)		UJ331C
Clamp Kit (Rr. Shaft; Rr.)		UJ492-10	Clamp Kit (Rr. Shaft; Rr.)		UJ492-10
1996-1994 K2500 w/ Reg. Cab & Diesel Eng.:			1996-1994 K2500 w/ Ext. Cab & Diesel Eng.:		
[Type 13]			[Type 14]		
U-Joint (Fr. Shaft; Frt.) ①		UJ355	U-Joint (Fr. Shaft; Frt.) ①		UJ355
<i>Brute Force Greaseable</i>		UJ290	<i>Brute Force Greaseable</i>		UJ290
(For Aluminum Drive Shaft)		UJ355C	(For Aluminum Drive Shaft)		UJ355C
Clamp Kit (Fr. Shaft; Frt.)		UJ530-10	Clamp Kit (Fr. Shaft; Frt.)		UJ530-10
U-Joint (Fr. Shaft; Rr.) ②		UJ354	U-Joint (Fr. Shaft; Rr.) ②		UJ354
<i>Brute Force Greaseable</i>		UJ270	<i>Brute Force Greaseable</i>		UJ270
<i>Brute Force Non Greaseable</i>		UJ254	<i>Brute Force Non Greaseable</i>		UJ254
(For Aluminum Drive Shaft)		UJ354C	(For Aluminum Drive Shaft)		UJ354C
U-Joint (Rr. Shaft; Frt.) ③		UJ331	U-Joint (Rr. Shaft; Frt.) ③		UJ331
<i>Brute Force Greaseable</i>		UJ232	<i>Brute Force Greaseable</i>		UJ232
<i>Brute Force Non Greaseable</i>		UJ231	<i>Brute Force Non Greaseable</i>		UJ231
(For Aluminum Drive Shaft)		UJ331C	(For Aluminum Drive Shaft)		UJ331C
Clamp Kit (Rr. Shaft; Frt.)		UJ492-10	Clamp Kit (Rr. Shaft; Frt.)		UJ492-10
U-Joint (Rr. Shaft; Rr.) ④		UJ331	U-Joint (Rr. Shaft; Rr.) ④		UJ331
<i>Brute Force Greaseable</i>		UJ232	<i>Brute Force Greaseable</i>		UJ232
<i>Brute Force Non Greaseable</i>		UJ231	<i>Brute Force Non Greaseable</i>		UJ231
(For Aluminum Drive Shaft)		UJ331C	(For Aluminum Drive Shaft)		UJ331C
Clamp Kit (Rr. Shaft; Rr.)		UJ492-10	Clamp Kit (Rr. Shaft; Rr.)		UJ492-10

(Continued)

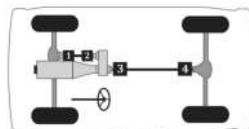

Type 13

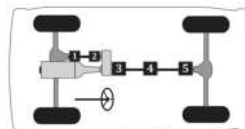

Type 14

Passenger cars, light & medium trucks

Chevrolet/GMC Truck 3/4 ton -- (Cont.)

MFG./YEAR	MODEL & LOCATION	PART NO.	MFG./YEAR	MODEL & LOCATION	PART NO.
-----------	------------------	----------	-----------	------------------	----------

Drive Shaft (4 W/D) (Cont.)

U-Joint (Cont.)

1993-1992 Suburban: [Type 13]

U-Joint (Fr. Shaft; Frt.) [⊙]	UJ534G
Brute Force Greaseable	UJ235
Brute Force Non Greaseable	UJ234
Clamp Kit (Fr. Shaft; Frt.)	UJ530-10
U-Joint (Fr. Shaft; Rr.) [⊙]	UJ534G
Brute Force Greaseable	UJ235
Brute Force Non Greaseable	UJ234
Clamp Kit (Fr. Shaft; Rr.)	UJ530-10
U-Joint (Rr. Shaft; Frt.) [⊙]	UJ331
Brute Force Greaseable	UJ232
Brute Force Non Greaseable	UJ231
(For Aluminum Drive Shaft)	UJ331C
Clamp Kit (Rr. Shaft; Frt.)	UJ492-10
U-Joint (Rr. Shaft; Rr.) [⊙]	UJ331
Brute Force Greaseable	UJ232
Brute Force Non Greaseable	UJ231
(For Aluminum Drive Shaft)	UJ331C
Clamp Kit (Rr. Shaft; Rr.)	UJ492-10

1993-1992 K2500 w/ Reg. Cab: [Type 13]

U-Joint (Fr. Shaft; Frt.) [⊙]	UJ534G
Brute Force Greaseable	UJ235
Brute Force Non Greaseable	UJ234
Clamp Kit (Fr. Shaft; Frt.)	UJ530-10
U-Joint (Fr. Shaft; Rr.) [⊙]	UJ534G
Brute Force Greaseable	UJ235
Brute Force Non Greaseable	UJ234
Clamp Kit (Fr. Shaft; Rr.)	UJ530-10
U-Joint (Rr. Shaft; Frt.) [⊙]	UJ331
Brute Force Greaseable	UJ232
Brute Force Non Greaseable	UJ231
(For Aluminum Drive Shaft)	UJ331C
Clamp Kit (Rr. Shaft; Frt.)	UJ492-10
U-Joint (Rr. Shaft; Rr.) [⊙]	UJ331
Brute Force Greaseable	UJ232
Brute Force Non Greaseable	UJ231
(For Aluminum Drive Shaft)	UJ331C
Clamp Kit (Rr. Shaft; Rr.)	UJ492-10

Drive Shaft (4 W/D) (Cont.)

U-Joint (Cont.)

1993-1992 K2500 w/ Ext. Cab: [Type 14]

U-Joint (Fr. Shaft; Frt.) [⊙]	UJ534G
Brute Force Greaseable	UJ235
Brute Force Non Greaseable	UJ234
Clamp Kit (Fr. Shaft; Frt.)	UJ530-10
U-Joint (Fr. Shaft; Rr.) [⊙]	UJ534G
Brute Force Greaseable	UJ235
Brute Force Non Greaseable	UJ234
Clamp Kit (Fr. Shaft; Rr.)	UJ530-10
U-Joint (Rr. Shaft; Frt.) [⊙]	UJ331
Brute Force Greaseable	UJ232
Brute Force Non Greaseable	UJ231
(For Aluminum Drive Shaft)	UJ331C
Clamp Kit (Rr. Shaft; Frt.)	UJ492-10
U-Joint (Rr. Shaft; Ctr.) [⊙]	UJ331
Brute Force Greaseable	UJ232
Brute Force Non Greaseable	UJ231
(For Aluminum Drive Shaft)	UJ331C
Clamp Kit (Rr. Shaft; Ctr.)	UJ492-10
U-Joint (Rr. Shaft; Rr.) [⊙]	UJ331
Brute Force Greaseable	UJ232
Brute Force Non Greaseable	UJ231
(For Aluminum Drive Shaft)	UJ331C
Clamp Kit (Rr. Shaft; Rr.)	UJ492-10

1991-1988 Suburban: [Type 26]

U-Joint (Fr. Shaft; Frt.) [⊙]	UJ369
Brute Force Greaseable	UJ280
Brute Force Non Greaseable	UJ269
(For Aluminum Drive Shaft)	UJ369C
U-Joint (Fr. Shaft; Rr.) [⊙]	[2] UJ534G
Brute Force Greaseable	UJ235
Brute Force Non Greaseable	UJ234
U-Joint (Rr. Shaft; Frt.) [⊙]	UJ331
Brute Force Greaseable	UJ232
Brute Force Non Greaseable	UJ231
(For Aluminum Drive Shaft)	UJ331C
Clamp Kit (Rr. Shaft; Frt.)	UJ492-10
U-Joint (Rr. Shaft; Rr.) [⊙]	UJ331
Brute Force Greaseable	UJ232
Brute Force Non Greaseable	UJ231
(For Aluminum Drive Shaft)	UJ331C
Clamp Kit (Rr. Shaft; Rr.)	UJ492-10
U-Joint (Wheel Joint) [⊙]	[2] UJ371
Brute Force Greaseable	UJ377
Brute Force Non Greaseable	UJ371
Ball Seat Repair Kit	UJ606
Flange Yoke	UJ626
H Yoke	UJ646

(Continued)

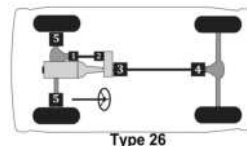
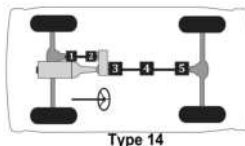
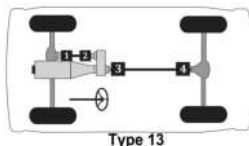

Passenger cars, light & medium trucks

(Cont.) -- Chevrolet/GMC Truck 3/4 ton

MFG./YEAR	MODEL & LOCATION	PART NO.	MFG./YEAR	MODEL & LOCATION	PART NO.
Drive Shaft (4 W/D) (Cont.)			Drive Shaft (4 W/D) (Cont.)		
U-Joint (Cont.)			U-Joint (Cont.)		
1991-1988 K2500 w/ Reg. Cab & Auto. Trans.:			1991-1988 K2500 w/ Ext. Cab & Auto. Trans.:		
[Type 13]			[Type 14]		
U-Joint (Fr. Shaft; Frt.) ①		UJ534G	U-Joint (Fr. Shaft; Frt.) ①		UJ534G
<i>Brute Force Greaseable</i>		UJ235	<i>Brute Force Greaseable</i>		UJ235
<i>Brute Force Non Greaseable</i>		UJ234	<i>Brute Force Non Greaseable</i>		UJ234
Clamp Kit (Fr. Shaft; Frt.)		UJ530-10	Clamp Kit (Fr. Shaft; Frt.)		UJ530-10
U-Joint (Fr. Shaft; Rr.) ②		UJ534G	U-Joint (Fr. Shaft; Rr.) ②		UJ534G
<i>Brute Force Greaseable</i>		UJ235	<i>Brute Force Greaseable</i>		UJ235
<i>Brute Force Non Greaseable</i>		UJ234	<i>Brute Force Non Greaseable</i>		UJ234
Clamp Kit (Fr. Shaft; Rr.)		UJ530-10	Clamp Kit (Fr. Shaft; Rr.)		UJ530-10
U-Joint (Rr. Shaft; Frt.) ③		UJ331	U-Joint (Rr. Shaft; Frt.) ③		UJ331
<i>Brute Force Greaseable</i>		UJ232	<i>Brute Force Greaseable</i>		UJ232
<i>Brute Force Non Greaseable</i>		UJ231	<i>Brute Force Non Greaseable</i>		UJ231
(For Aluminum Drive Shaft)		UJ331C	(For Aluminum Drive Shaft)		UJ331C
Clamp Kit (Rr. Shaft; Frt.)		UJ492-10	Clamp Kit (Rr. Shaft; Frt.)		UJ492-10
U-Joint (Rr. Shaft; Rr.) ④		UJ331	U-Joint (Rr. Shaft; Rr.) ④		UJ331
<i>Brute Force Greaseable</i>		UJ232	<i>Brute Force Greaseable</i>		UJ232
<i>Brute Force Non Greaseable</i>		UJ231	<i>Brute Force Non Greaseable</i>		UJ231
(For Aluminum Drive Shaft)		UJ331C	(For Aluminum Drive Shaft)		UJ331C
Clamp Kit (Rr. Shaft; Rr.)		UJ492-10	Clamp Kit (Rr. Shaft; Rr.)		UJ492-10
1991-1988 K2500 w/ Reg. Cab & Man. Trans.:			1991-1988 K2500 w/ Ext. Cab & Man. Trans.:		
[Type 13]			[Type 14]		
U-Joint (Fr. Shaft; Frt.) ①		UJ355	U-Joint (Fr. Shaft; Frt.) ①		UJ355
<i>Brute Force Greaseable</i>		UJ290	<i>Brute Force Greaseable</i>		UJ290
(For Aluminum Drive Shaft)		UJ355C	(For Aluminum Drive Shaft)		UJ355C
Clamp Kit (Fr. Shaft; Frt.)		UJ530-10	Clamp Kit (Fr. Shaft; Frt.)		UJ530-10
U-Joint (Fr. Shaft; Rr.) ②		UJ354	U-Joint (Fr. Shaft; Rr.) ②		UJ354
<i>Brute Force Greaseable</i>		UJ270	<i>Brute Force Greaseable</i>		UJ270
<i>Brute Force Non Greaseable</i>		UJ254	<i>Brute Force Non Greaseable</i>		UJ254
(For Aluminum Drive Shaft)		UJ354C	(For Aluminum Drive Shaft)		UJ354C
U-Joint (Rr. Shaft; Frt.) ③		UJ331	U-Joint (Rr. Shaft; Frt.) ③		UJ331
<i>Brute Force Greaseable</i>		UJ232	<i>Brute Force Greaseable</i>		UJ232
<i>Brute Force Non Greaseable</i>		UJ231	<i>Brute Force Non Greaseable</i>		UJ231
(For Aluminum Drive Shaft)		UJ331C	(For Aluminum Drive Shaft)		UJ331C
Clamp Kit (Rr. Shaft; Frt.)		UJ492-10	Clamp Kit (Rr. Shaft; Frt.)		UJ492-10
U-Joint (Rr. Shaft; Rr.) ④		UJ331	U-Joint (Rr. Shaft; Rr.) ④		UJ331
<i>Brute Force Greaseable</i>		UJ232	<i>Brute Force Greaseable</i>		UJ232
<i>Brute Force Non Greaseable</i>		UJ231	<i>Brute Force Non Greaseable</i>		UJ231
(For Aluminum Drive Shaft)		UJ331C	(For Aluminum Drive Shaft)		UJ331C
Clamp Kit (Rr. Shaft; Rr.)		UJ492-10	Clamp Kit (Rr. Shaft; Rr.)		UJ492-10
			1991-1988 K2500 w/ Ext. Cab & Man. Trans.:		
			[Type 14]		
			U-Joint (Fr. Shaft; Frt.) ①		UJ355
			<i>Brute Force Greaseable</i>		UJ290
			(For Aluminum Drive Shaft)		UJ355C
			Clamp Kit (Fr. Shaft; Frt.)		UJ530-10
			U-Joint (Fr. Shaft; Rr.) ②		UJ354
			<i>Brute Force Greaseable</i>		UJ270
			<i>Brute Force Non Greaseable</i>		UJ254
			(For Aluminum Drive Shaft)		UJ354C
			U-Joint (Rr. Shaft; Frt.) ③		UJ331
			<i>Brute Force Greaseable</i>		UJ232
			<i>Brute Force Non Greaseable</i>		UJ231
			(For Aluminum Drive Shaft)		UJ331C
			Clamp Kit (Rr. Shaft; Frt.)		UJ492-10
			U-Joint (Rr. Shaft; Ctr.) ④		UJ331
			<i>Brute Force Greaseable</i>		UJ232
			<i>Brute Force Non Greaseable</i>		UJ231
			(For Aluminum Drive Shaft)		UJ331C
			Clamp Kit (Rr. Shaft; Ctr.)		UJ492-10
			U-Joint (Rr. Shaft; Rr.) ⑤		UJ331
			<i>Brute Force Greaseable</i>		UJ232
			<i>Brute Force Non Greaseable</i>		UJ231
			(For Aluminum Drive Shaft)		UJ331C
			Clamp Kit (Rr. Shaft; Rr.)		UJ492-10

(Continued)

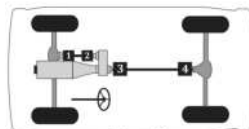

Type 13

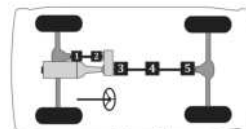

Type 14

Passenger cars, light & medium trucks

Chevrolet/GMC Truck 3/4 ton -- (Cont.)

MFG./YEAR	MODEL & LOCATION	PART NO.	MFG./YEAR	MODEL & LOCATION	PART NO.
Drive Shaft (4 W/D) (Cont.)			Drive Shaft (4 W/D) (Cont.)		
U-Joint (Cont.)			U-Joint (Cont.)		
1987	V20 & V2500: [Type 26]		1981-1979	K20 & K2500 w/ 2 Joint Shaft: [Type 26]	
	U-Joint (Fr. Shaft; Frt.) [⊙]	UJ369		U-Joint (Fr. Shaft; Frt.) [⊙]	UJ369
	Brute Force Greaseable	UJ280		Brute Force Greaseable	UJ280
	Brute Force Non Greaseable	UJ269		Brute Force Non Greaseable	UJ269
	(For Aluminum Drive Shaft)	UJ369C		(For Aluminum Drive Shaft)	UJ369C
	Clamp Kit (Fr. Shaft; Frt.)	UJ360-10		Clamp Kit (Fr. Shaft; Frt.)	UJ360-10
	U-Joint (Fr. Shaft; Rr.) [⊙]	[2] UJ534G		U-Joint (Fr. Shaft; Rr.) [⊙]	[2] UJ534G
	Brute Force Greaseable	UJ235		Brute Force Greaseable	UJ235
	Brute Force Non Greaseable	UJ234		Brute Force Non Greaseable	UJ234
	U-Joint (Rr. Shaft; Frt.) [⊙]	UJ331		U-Joint (Rr. Shaft; Frt.) [⊙]	UJ331
	Brute Force Greaseable	UJ232		Brute Force Greaseable	UJ232
	Brute Force Non Greaseable	UJ231		Brute Force Non Greaseable	UJ231
	(For Aluminum Drive Shaft)	UJ331C		(For Aluminum Drive Shaft)	UJ331C
	U-Joint (Rr. Shaft; Rr.) [⊙]	UJ331		U-Joint (Rr. Shaft; Rr.) [⊙]	UJ331
	Brute Force Greaseable	UJ232		Brute Force Greaseable	UJ232
	Brute Force Non Greaseable	UJ231		Brute Force Non Greaseable	UJ231
	(For Aluminum Drive Shaft)	UJ331C		(For Aluminum Drive Shaft)	UJ331C
	U-Joint (Wheel Joint) [⊙]	[2] UJ371		U-Joint (Wheel Joint) [⊙]	[2] UJ371
	Brute Force Greaseable	UJ377		Brute Force Greaseable	UJ377
	Brute Force Non Greaseable	UJ371		Brute Force Non Greaseable	UJ371
	Ball Seat Repair Kit	UJ606		Ball Seat Repair Kit	UJ606
	1986-1982 K20 & K2500: [Type 26]			Flange Yoke	UJ626
	U-Joint (Fr. Shaft; Frt.) [⊙]	UJ369		H Yoke	UJ646
	Brute Force Greaseable	UJ280			(Continued)
	Brute Force Non Greaseable	UJ269			
	(For Aluminum Drive Shaft)	UJ369C			
	Clamp Kit (Fr. Shaft; Frt.)	UJ360-10			
	U-Joint (Fr. Shaft; Rr.) [⊙]	[2] UJ534G			
	Brute Force Greaseable	UJ235			
	Brute Force Non Greaseable	UJ234			
	U-Joint (Rr. Shaft; Frt.) [⊙]	UJ331			
	Brute Force Greaseable	UJ232			
	Brute Force Non Greaseable	UJ231			
	(For Aluminum Drive Shaft)	UJ331C			
	U-Joint (Rr. Shaft; Rr.) [⊙]	UJ331			
	Brute Force Greaseable	UJ232			
	Brute Force Non Greaseable	UJ231			
	(For Aluminum Drive Shaft)	UJ331C			
	U-Joint (Wheel Joint) [⊙]	[2] UJ371			
	Brute Force Greaseable	UJ377			
	Brute Force Non Greaseable	UJ371			
	Ball Seat Repair Kit	UJ606			
	Flange Yoke	UJ626			
	H Yoke	UJ646			

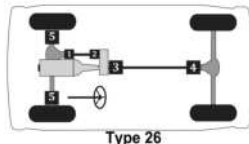

(Cont.) -- Chevrolet/GMC Truck 3/4 ton

MFG./YEAR	MODEL & LOCATION	PART NO.	MFG./YEAR	MODEL & LOCATION	PART NO.
Drive Shaft (4 W/D) (Cont.)			Drive Shaft (4 W/D) (Cont.)		
U-Joint (Cont.)			U-Joint (Cont.)		
1981-1979 K20 & K2500 w/ 3 Joint Shaft: [Type 27]			1978-1977 K20 & K25 w/ 2 Joint Shaft & Inner Lock Rings: [Type 26]		
U-Joint (Fr. Shaft; Fr.) ①		UJ369	U-Joint (Fr. Shaft; Fr.) ①		UJ369
Brute Force Greaseable		UJ280	Brute Force Greaseable		UJ280
Brute Force Non Greaseable		UJ269	Brute Force Non Greaseable		UJ269
(For Aluminum Drive Shaft)		UJ369C	(For Aluminum Drive Shaft)		UJ369C
U-Joint (Fr. Shaft; Rr.) ②	[2]	UJ534G	U-Bolt Kit (Fr. Shaft; Fr.)		UJ329-10
Brute Force Greaseable		UJ235	U-Joint (Fr. Shaft; Rr.) ②	[2]	UJ534G
Brute Force Non Greaseable		UJ234	Brute Force Greaseable		UJ235
U-Joint (Rr. Shaft; Fr.) ③		UJ331	Brute Force Non Greaseable		UJ234
Brute Force Greaseable		UJ232	U-Joint (Rr. Shaft; Fr.) ③		UJ369
Brute Force Non Greaseable		UJ231	Brute Force Greaseable		UJ280
(For Aluminum Drive Shaft)		UJ331C	Brute Force Non Greaseable		UJ269
U-Joint (Rr. Shaft; Ctr.) ④		UJ331	(For Aluminum Drive Shaft)		UJ369C
Brute Force Greaseable		UJ232	U-Bolt Kit (Rr. Shaft; Fr.)		UJ329-10
Brute Force Non Greaseable		UJ231	U-Joint (Rr. Shaft; Rr.) ⑤		UJ331
(For Aluminum Drive Shaft)		UJ331C	Brute Force Greaseable		UJ232
U-Joint (Rr. Shaft; Rr.) ⑤		UJ331	Brute Force Non Greaseable		UJ231
Brute Force Greaseable		UJ232	(For Aluminum Drive Shaft)		UJ331C
Brute Force Non Greaseable		UJ231	U-Joint (Wheel Joint) ⑥	[2]	UJ371
(For Aluminum Drive Shaft)		UJ331C	Brute Force Greaseable		UJ377
U-Joint (Wheel Joint) ⑥	[2]	UJ371	Brute Force Non Greaseable		UJ371
Brute Force Greaseable		UJ377	Ball Seat Repair Kit		UJ606
Brute Force Non Greaseable		UJ371	Flange Yoke		UJ626
Ball Seat Repair Kit		UJ606	H Yoke		UJ646
Flange Yoke		UJ626	1978-1977 K20 & K25 w/ 2 Joint Shaft & Outer Lock Rings: [Type 26]		
H Yoke		UJ646	U-Joint (Fr. Shaft; Fr.) ①		UJ369
			Brute Force Greaseable		UJ280
			Brute Force Non Greaseable		UJ269
			(For Aluminum Drive Shaft)		UJ369C
			U-Bolt Kit (Fr. Shaft; Fr.)		UJ329-10
			U-Joint (Fr. Shaft; Rr.) ②	[2]	UJ379
			Brute Force Greaseable		UJ280
			Brute Force Non Greaseable		UJ269
			U-Joint (Rr. Shaft; Fr.) ③		UJ369
			Brute Force Greaseable		UJ280
			Brute Force Non Greaseable		UJ269
			(For Aluminum Drive Shaft)		UJ369C
			U-Bolt Kit (Rr. Shaft; Fr.)		UJ329-10
			U-Joint (Rr. Shaft; Rr.) ④		UJ331
			Brute Force Greaseable		UJ232
			Brute Force Non Greaseable		UJ231
			(For Aluminum Drive Shaft)		UJ331C
			U-Joint (Wheel Joint) ⑥	[2]	UJ371
			Brute Force Greaseable		UJ377
			Brute Force Non Greaseable		UJ371
			Centering Yoke		UJ607
			H Yoke		UJ647

(Continued)

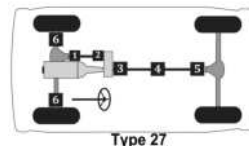
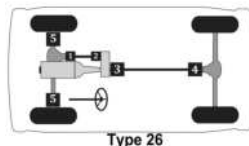

Passenger cars, light & medium trucks

Chevrolet/GMC Truck 3/4 ton -- (Cont.)

MFG./YEAR	MODEL & LOCATION	PART NO.	MFG./YEAR	MODEL & LOCATION	PART NO.
-----------	------------------	----------	-----------	------------------	----------

Drive Shaft (4 W/D) (Cont.)

U-Joint (Cont.)

1978-1977 K20 & K25 w/ 3 Joint Shaft & Inner

Lock Rings: [Type 27]

U-Joint (Fr. Shaft; Frt.) [⊙]	UJ369
Brute Force Greaseable	UJ280
Brute Force Non Greaseable	UJ269
(For Aluminum Drive Shaft)	UJ369C
U-Bolt Kit (Fr. Shaft; Frt.)	UJ329-10
U-Joint (Fr. Shaft; Rr.) [⊙]	[2] UJ534G
Brute Force Greaseable	UJ235
Brute Force Non Greaseable	UJ234
U-Joint (Rr. Shaft; Frt.) [⊙]	UJ331
Brute Force Greaseable	UJ232
Brute Force Non Greaseable	UJ231
(For Aluminum Drive Shaft)	UJ331C
U-Joint (Rr. Shaft; Ctr.) [⊙]	UJ331
Brute Force Greaseable	UJ232
Brute Force Non Greaseable	UJ231
(For Aluminum Drive Shaft)	UJ331C
U-Joint (Rr. Shaft; Rr.) [⊙]	UJ331
Brute Force Greaseable	UJ232
Brute Force Non Greaseable	UJ231
(For Aluminum Drive Shaft)	UJ331C
U-Joint (Wheel Joint) [⊙]	[2] UJ371
Brute Force Greaseable	UJ377
Brute Force Non Greaseable	UJ371
Ball Seat Repair Kit	UJ606
Flange Yoke	UJ626
H Yoke	UJ646

Drive Shaft (4 W/D) (Cont.)

U-Joint (Cont.)

1978-1977 K20 & K25 w/ 3 Joint Shaft & Outer

Lock Rings: [Type 27]

U-Joint (Fr. Shaft; Frt.) [⊙]	UJ369
Brute Force Greaseable	UJ280
Brute Force Non Greaseable	UJ269
(For Aluminum Drive Shaft)	UJ369C
U-Bolt Kit (Fr. Shaft; Frt.)	UJ329-10
U-Joint (Fr. Shaft; Rr.) [⊙]	[2] UJ379
Brute Force Greaseable	UJ280
Brute Force Non Greaseable	UJ269
U-Joint (Rr. Shaft; Frt.) [⊙]	UJ331
Brute Force Greaseable	UJ232
Brute Force Non Greaseable	UJ231
(For Aluminum Drive Shaft)	UJ331C
U-Joint (Rr. Shaft; Ctr.) [⊙]	UJ331
Brute Force Greaseable	UJ232
Brute Force Non Greaseable	UJ231
(For Aluminum Drive Shaft)	UJ331C
U-Joint (Rr. Shaft; Rr.) [⊙]	UJ331
Brute Force Greaseable	UJ232
Brute Force Non Greaseable	UJ231
(For Aluminum Drive Shaft)	UJ331C
U-Joint (Wheel Joint) [⊙]	[2] UJ371
Brute Force Greaseable	UJ377
Brute Force Non Greaseable	UJ371
Centering Yoke	UJ607
H Yoke	UJ647

(Continued)

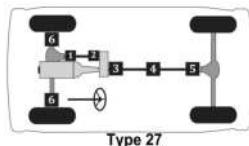

Type 27

MFG./YEAR	MODEL & LOCATION	PART NO.	MFG./YEAR	MODEL & LOCATION	PART NO.
Drive Shaft (4 W/D) (Cont.)			Drive Shaft (4 W/D) (Cont.)		
U-Joint (Cont.)			U-Joint (Cont.)		
1976-1975 K20 & K25 w/ Full Time Transfer Case:			1976-1975 K20 & K25 w/ Part Time Transfer Case		
[Type 26]			& 3 Joint Shaft: [Type 27]		
U-Joint (Fr. Shaft; Frt.)①		UJ369	U-Joint (Fr. Shaft; Frt.)①		UJ369
Brute Force Greaseable		UJ280	Brute Force Greaseable		UJ280
Brute Force Non Greaseable		UJ269	Brute Force Non Greaseable		UJ269
(For Aluminum Drive Shaft)		UJ369C	(For Aluminum Drive Shaft)		UJ369C
U-Bolt Kit (Fr. Shaft; Frt.)		UJ329-10	U-Bolt Kit (Fr. Shaft; Frt.)		UJ329-10
U-Joint (Fr. Shaft; Rr.)②	[2]	UJ379	U-Joint (Fr. Shaft; Rr.)②	[2]	UJ379
Brute Force Greaseable		UJ280	Brute Force Greaseable		UJ280
Brute Force Non Greaseable		UJ269	Brute Force Non Greaseable		UJ269
U-Joint (Rr. Shaft; Frt.)③		UJ369	U-Joint (Rr. Shaft; Frt.)③		UJ331
Brute Force Greaseable		UJ280	Brute Force Greaseable		UJ232
Brute Force Non Greaseable		UJ269	Brute Force Non Greaseable		UJ231
(For Aluminum Drive Shaft)		UJ369C	(For Aluminum Drive Shaft)		UJ331C
U-Bolt Kit (Rr. Shaft; Frt.)		UJ329-10	U-Joint (Rr. Shaft; Ctr.)④		UJ331
U-Joint (Rr. Shaft; Rr.)④		UJ369	Brute Force Greaseable		UJ232
Brute Force Greaseable		UJ280	Brute Force Non Greaseable		UJ231
Brute Force Non Greaseable		UJ269	(For Aluminum Drive Shaft)		UJ331C
(For Aluminum Drive Shaft)		UJ369C	U-Joint (Rr. Shaft; Rr.)⑤		UJ331
U-Bolt Kit (Rr. Shaft; Rr.)		UJ329-10	Brute Force Greaseable		UJ232
U-Joint (Wheel Joint)⑥	[2]	UJ371	Brute Force Non Greaseable		UJ231
Brute Force Greaseable		UJ377	(For Aluminum Drive Shaft)		UJ331C
Brute Force Non Greaseable		UJ371	U-Joint (Wheel Joint)⑥	[2]	UJ371
Centering Yoke		UJ607	Brute Force Greaseable		UJ377
H Yoke		UJ647	Brute Force Non Greaseable		UJ371
			Centering Yoke		UJ607
			H Yoke		UJ647
1976-1975 K20 & K25 w/ Part Time Transfer Case			1974-1973 K20 & K25: [Type 26]		
& 2 Joint Shaft: [Type 26]			U-Joint (Fr. Shaft; Frt.)①		UJ369
U-Joint (Fr. Shaft; Frt.)①		UJ369	Brute Force Greaseable		UJ280
Brute Force Greaseable		UJ280	Brute Force Non Greaseable		UJ269
Brute Force Non Greaseable		UJ269	(For Aluminum Drive Shaft)		UJ369C
(For Aluminum Drive Shaft)		UJ369C	U-Bolt Kit (Fr. Shaft; Frt.)		UJ329-10
U-Bolt Kit (Fr. Shaft; Frt.)		UJ329-10	U-Joint (Fr. Shaft; Rr.)②	[2]	UJ379
U-Joint (Fr. Shaft; Rr.)②	[2]	UJ379	Brute Force Greaseable		UJ280
Brute Force Greaseable		UJ280	Brute Force Non Greaseable		UJ269
Brute Force Non Greaseable		UJ269	U-Joint (Rr. Shaft; Frt.)③		UJ331
U-Joint (Rr. Shaft; Frt.)③		UJ331	Brute Force Greaseable		UJ232
Brute Force Greaseable		UJ232	Brute Force Non Greaseable		UJ231
Brute Force Non Greaseable		UJ231	(For Aluminum Drive Shaft)		UJ331C
(For Aluminum Drive Shaft)		UJ331C	U-Joint (Rr. Shaft; Rr.)④		UJ331
U-Joint (Rr. Shaft; Rr.)④		UJ331	Brute Force Greaseable		UJ232
Brute Force Greaseable		UJ232	Brute Force Non Greaseable		UJ231
Brute Force Non Greaseable		UJ231	(For Aluminum Drive Shaft)		UJ331C
(For Aluminum Drive Shaft)		UJ331C	U-Joint (Rr. Shaft; Rr.)④		UJ331
U-Joint (Wheel Joint)⑥	[2]	UJ371	Brute Force Greaseable		UJ232
Brute Force Greaseable		UJ377	Brute Force Non Greaseable		UJ231
Brute Force Non Greaseable		UJ371	(For Aluminum Drive Shaft)		UJ331C
Centering Yoke		UJ607	U-Joint (Wheel Joint)⑥	[2]	UJ371
H Yoke		UJ647	Brute Force Greaseable		UJ377
			Brute Force Non Greaseable		UJ371
			Centering Yoke		UJ607
			H Yoke		UJ647

(Continued)

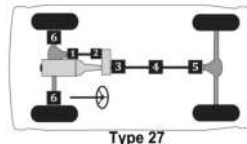
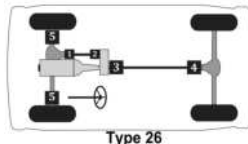

Passenger cars, light & medium trucks

Chevrolet/GMC Truck 3/4 ton -- (Cont.)

MFG./YEAR	MODEL & LOCATION	PART NO.	MFG./YEAR	MODEL & LOCATION	PART NO.
-----------	------------------	----------	-----------	------------------	----------

Drive Shaft (4 W/D) (Cont.)

U-Joint (Cont.)

1972-1967 K20 & K25 w/ 1.063" Dia. Rr. Shaft

Brg. Cap: [Type 26]

U-Joint (Fr. Shaft; Frt.) [⊙]	UJ369
Brute Force Greaseable	UJ280
Brute Force Non Greaseable	UJ269
(For Aluminum Drive Shaft)	UJ369C
U-Bolt Kit (Fr. Shaft; Frt.)	UJ329-10
U-Joint (Fr. Shaft; Rr.) [⊙]	[2] UJ379
Brute Force Greaseable	UJ280
Brute Force Non Greaseable	UJ269
U-Joint (Rr. Shaft; Frt.) [⊙]	UJ369
Brute Force Greaseable	UJ280
Brute Force Non Greaseable	UJ269
(For Aluminum Drive Shaft)	UJ369C
U-Bolt Kit (Rr. Shaft; Frt.)	UJ329-10
U-Joint (Rr. Shaft; Rr.) [⊙]	UJ369
Brute Force Greaseable	UJ280
Brute Force Non Greaseable	UJ269
(For Aluminum Drive Shaft)	UJ369C
U-Bolt Kit (Rr. Shaft; Rr.)	UJ329-10
U-Joint (Wheel Joint) [⊙]	[2] UJ365
Brute Force Greaseable	UJ378
Brute Force Non Greaseable	UJ365
Centering Yoke	UJ607
Weld Yoke	UJ633

1972-1967 K20 & K25 w/ 1.188" Dia. Rr. Shaft

Brg. Cap: [Type 26]

U-Joint (Fr. Shaft; Frt.) [⊙]	UJ369
Brute Force Greaseable	UJ280
Brute Force Non Greaseable	UJ269
(For Aluminum Drive Shaft)	UJ369C
U-Bolt Kit (Fr. Shaft; Frt.)	UJ329-10
U-Joint (Fr. Shaft; Rr.) [⊙]	[2] UJ379
Brute Force Greaseable	UJ280
Brute Force Non Greaseable	UJ269
U-Joint (Rr. Shaft; Frt.) [⊙]	UJ331
Brute Force Greaseable	UJ232
Brute Force Non Greaseable	UJ231
(For Aluminum Drive Shaft)	UJ331C
U-Bolt Kit (Rr. Shaft; Frt.)	UJ330-10
U-Joint (Rr. Shaft; Rr.) [⊙]	UJ331
Brute Force Greaseable	UJ232
Brute Force Non Greaseable	UJ231
(For Aluminum Drive Shaft)	UJ331C
U-Bolt Kit (Rr. Shaft; Rr.)	UJ330-10
U-Joint (Wheel Joint) [⊙]	[2] UJ365
Brute Force Greaseable	UJ378
Brute Force Non Greaseable	UJ365
Centering Yoke	UJ607
Weld Yoke	UJ633
H Yoke	UJ647

Drive Shaft (4 W/D) (Cont.)

U-Joint (Cont.)

1966-1961 K20 & 2500 Series w/ 3 Spd. Man.

Trans. & Inner Lock Rings: [Type 34]

U-Joint (Fr. Shaft; Frt.) [⊙]	UJ369
Brute Force Greaseable	UJ280
Brute Force Non Greaseable	UJ269
(For Aluminum Drive Shaft)	UJ369C
U-Bolt Kit (Fr. Shaft; Frt.)	UJ329-10
U-Joint (Fr. Shaft; Rr.) [⊙]	UJ369
Brute Force Greaseable	UJ280
Brute Force Non Greaseable	UJ269
(For Aluminum Drive Shaft)	UJ369C
U-Bolt Kit (Fr. Shaft; Rr.)	UJ329-10
U-Joint (Intmd. Shaft; Frt.) [⊙]	UJ369
Brute Force Greaseable	UJ280
Brute Force Non Greaseable	UJ269
(For Aluminum Drive Shaft)	UJ369C
U-Bolt Kit (Intmd. Shaft; Frt.)	UJ329-10
U-Joint (Intmd. Shaft; Rr.) [⊙]	UJ369
Brute Force Greaseable	UJ280
Brute Force Non Greaseable	UJ269
(For Aluminum Drive Shaft)	UJ369C
U-Bolt Kit (Intmd. Shaft; Rr.)	UJ329-10
U-Joint (Rr. Shaft; Frt.) [⊙]	UJ331
Brute Force Greaseable	UJ232
Brute Force Non Greaseable	UJ231
(For Aluminum Drive Shaft)	UJ331C
U-Bolt Kit (Rr. Shaft; Frt.)	UJ330-10
U-Joint (Rr. Shaft; Rr.) [⊙]	UJ331
Brute Force Greaseable	UJ232
Brute Force Non Greaseable	UJ231
(For Aluminum Drive Shaft)	UJ331C
U-Bolt Kit (Rr. Shaft; Rr.)	UJ330-10
U-Joint (Wheel Joint) [⊙]	[2] UJ365
Brute Force Greaseable	UJ378
Brute Force Non Greaseable	UJ365

(Continued)

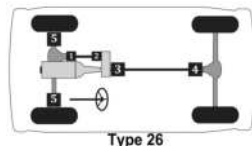

Type 26

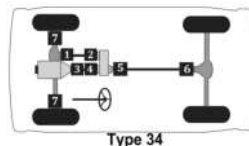

Type 34

Passenger cars, light & medium trucks

(Cont.) -- Chevrolet/GMC Truck 3/4 ton

MFG./YEAR	MODEL & LOCATION	PART NO.	MFG./YEAR	MODEL & LOCATION	PART NO.
Drive Shaft (4 W/D) (Cont.)			Drive Shaft (4 W/D) (Cont.)		
U-Joint (Cont.)			U-Joint (Cont.)		
1966-1961 K20 & 2500 Series w/ 3 Spd. Man.			1966-1961 K20 & 2500 Series w/ 4 Spd. Man.		
Trans. & Outer Lock Rings: [Type 34]			Trans. & Inner Lock Rings: [Type 34]		
U-Joint (Frnt. Shaft; Frt.) ^①		UJ369	U-Joint (Frnt. Shaft; Frt.) ^①		UJ369
Brute Force Greaseable		UJ280	Brute Force Greaseable		UJ280
Brute Force Non Greaseable		UJ269	Brute Force Non Greaseable		UJ269
(For Aluminum Drive Shaft)		UJ369C	(For Aluminum Drive Shaft)		UJ369C
U-Bolt Kit (Frnt. Shaft; Frt.)		UJ329-10	U-Bolt Kit (Frnt. Shaft; Frt.)		UJ329-10
U-Joint (Frnt. Shaft; Rr.) ^②		UJ369	U-Joint (Frnt. Shaft; Rr.) ^②		UJ369
Brute Force Greaseable		UJ280	Brute Force Greaseable		UJ280
Brute Force Non Greaseable		UJ269	Brute Force Non Greaseable		UJ269
(For Aluminum Drive Shaft)		UJ369C	(For Aluminum Drive Shaft)		UJ369C
U-Bolt Kit (Frnt. Shaft; Rr.)		UJ329-10	U-Bolt Kit (Frnt. Shaft; Rr.)		UJ329-10
U-Joint (Intmd. Shaft; Frt.) ^③		UJ369	U-Joint (Intmd. Shaft; Frt.) ^③		UJ331
Brute Force Greaseable		UJ280	Brute Force Greaseable		UJ232
Brute Force Non Greaseable		UJ269	Brute Force Non Greaseable		UJ231
(For Aluminum Drive Shaft)		UJ369C	(For Aluminum Drive Shaft)		UJ331C
U-Bolt Kit (Intmd. Shaft; Frt.)		UJ329-10	U-Bolt Kit (Intmd. Shaft; Frt.)		UJ329-10
U-Joint (Intmd. Shaft; Rr.) ^④		UJ369	U-Joint (Intmd. Shaft; Rr.) ^④		UJ369
Brute Force Greaseable		UJ280	Brute Force Greaseable		UJ280
Brute Force Non Greaseable		UJ269	Brute Force Non Greaseable		UJ269
(For Aluminum Drive Shaft)		UJ369C	(For Aluminum Drive Shaft)		UJ369C
U-Bolt Kit (Intmd. Shaft; Rr.)		UJ329-10	U-Bolt Kit (Intmd. Shaft; Rr.)		UJ329-10
U-Joint (Rr. Shaft; Frt.) ^⑤		UJ331	U-Joint (Rr. Shaft; Frt.) ^⑤		UJ331
Brute Force Greaseable		UJ232	Brute Force Greaseable		UJ232
Brute Force Non Greaseable		UJ231	Brute Force Non Greaseable		UJ231
(For Aluminum Drive Shaft)		UJ331C	(For Aluminum Drive Shaft)		UJ331C
U-Bolt Kit (Rr. Shaft; Frt.)		UJ330-10	U-Bolt Kit (Rr. Shaft; Frt.)		UJ330-10
U-Joint (Rr. Shaft; Rr.) ^⑥		UJ331	U-Joint (Rr. Shaft; Rr.) ^⑥		UJ331
Brute Force Greaseable		UJ232	Brute Force Greaseable		UJ232
Brute Force Non Greaseable		UJ231	Brute Force Non Greaseable		UJ231
(For Aluminum Drive Shaft)		UJ331C	(For Aluminum Drive Shaft)		UJ331C
U-Bolt Kit (Rr. Shaft; Rr.)		UJ330-10	U-Bolt Kit (Rr. Shaft; Rr.)		UJ330-10
U-Joint (Wheel Joint) ^⑦	[2]	UJ231	U-Joint (Wheel Joint) ^⑦	[2]	UJ365
(For Aluminum Drive Shaft)		UJ231C	Brute Force Greaseable		UJ378
			Brute Force Non Greaseable		UJ365

(Continued)

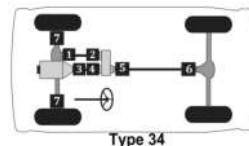

Passenger cars, light & medium trucks

Chevrolet/GMC Truck 3/4 ton -- (Cont.)

MFG./YEAR	MODEL & LOCATION	PART NO.	MFG./YEAR	MODEL & LOCATION	PART NO.
Drive Shaft (4 W/D) (Cont.)			Drive Shaft (4 W/D) (Cont.)		
U-Joint (Cont.)			U-Joint (Cont.)		
			1966-1961 K20 & 2500 Series w/ 4 Spd. Man.		
			Trans. & Outer Lock Rings: [Type 34]		
	U-Joint (Frnt. Shaft; Frt.) ⊙	UJ369		U-Joint (Frnt. Shaft; Frt.) ⊙	UJ369
	<i>Brute Force Greaseable</i>	UJ280		<i>Brute Force Greaseable</i>	UJ280
	<i>Brute Force Non Greaseable</i>	UJ269		<i>Brute Force Non Greaseable</i>	UJ269
	(For Aluminum Drive Shaft)	UJ369C		(For Aluminum Drive Shaft)	UJ369C
	U-Bolt Kit (Frnt. Shaft; Frt.)	UJ329-10		U-Bolt Kit (Frnt. Shaft; Frt.)	UJ329-10
	U-Joint (Frnt. Shaft; Rr.) ⊙	UJ369		U-Joint (Frnt. Shaft; Rr.) ⊙	UJ369
	<i>Brute Force Greaseable</i>	UJ280		<i>Brute Force Greaseable</i>	UJ280
	<i>Brute Force Non Greaseable</i>	UJ269		<i>Brute Force Non Greaseable</i>	UJ269
	(For Aluminum Drive Shaft)	UJ369C		(For Aluminum Drive Shaft)	UJ369C
	U-Bolt Kit (Frnt. Shaft; Rr.)	UJ329-10		U-Bolt Kit (Frnt. Shaft; Rr.)	UJ329-10
	U-Joint (Intmd. Shaft; Frt.) ⊙	UJ331		U-Joint (Intmd. Shaft; Frt.) ⊙	UJ331
	<i>Brute Force Greaseable</i>	UJ232		<i>Brute Force Greaseable</i>	UJ232
	<i>Brute Force Non Greaseable</i>	UJ231		<i>Brute Force Non Greaseable</i>	UJ231
	(For Aluminum Drive Shaft)	UJ331C		(For Aluminum Drive Shaft)	UJ331C
	U-Joint (Intmd. Shaft; Rr.) ⊙	UJ369		U-Joint (Intmd. Shaft; Rr.) ⊙	UJ369
	<i>Brute Force Greaseable</i>	UJ280		<i>Brute Force Greaseable</i>	UJ280
	<i>Brute Force Non Greaseable</i>	UJ269		<i>Brute Force Non Greaseable</i>	UJ269
	(For Aluminum Drive Shaft)	UJ369C		(For Aluminum Drive Shaft)	UJ369C
	U-Bolt Kit (Intmd. Shaft; Rr.)	UJ329-10		U-Bolt Kit (Intmd. Shaft; Rr.)	UJ329-10
	U-Joint (Rr. Shaft; Frt.) ⊙	UJ331		U-Joint (Rr. Shaft; Frt.) ⊙	UJ331
	<i>Brute Force Greaseable</i>	UJ232		<i>Brute Force Greaseable</i>	UJ232
	<i>Brute Force Non Greaseable</i>	UJ231		<i>Brute Force Non Greaseable</i>	UJ231
	(For Aluminum Drive Shaft)	UJ331C		(For Aluminum Drive Shaft)	UJ331C
	U-Bolt Kit (Rr. Shaft; Frt.)	UJ330-10		U-Bolt Kit (Rr. Shaft; Frt.)	UJ330-10
	U-Joint (Rr. Shaft; Rr.) ⊙	UJ331		U-Joint (Rr. Shaft; Rr.) ⊙	UJ331

Chevrolet/GMC Truck 1 ton

<p>Drive Shaft (2 W/D)</p> <p>U-Joint</p> <p>2020-2007 Silverado & Sierra HD: [Type 2]</p> <p>U-Joint (Front)⊙ UJ330A</p> <p><i>Brute Force Greaseable</i> UJ295A</p> <p>Clamp Kit (Front) UJ492-10</p> <p>U-Joint (Center)⊙ UJ351A</p> <p><i>Brute Force Non Greaseable</i> UJ351ABF</p> <p>U-Joint (Rear)⊙ UJ351A</p> <p><i>Brute Force Non Greaseable</i> UJ351ABF</p> <p>2007 Silverado & Sierra Classic w/ 6.0L Eng., Ext. Cab & Long Bed: [Type 2]</p> <p>U-Joint (Front)⊙ UJ330A</p> <p><i>Brute Force Greaseable</i> UJ295A</p> <p>Clamp Kit (Front) UJ492-10</p> <p>U-Joint (Center)⊙ UJ330A</p> <p><i>Brute Force Greaseable</i> UJ295A</p> <p>Clamp Kit (Center) UJ492-10</p> <p>U-Joint (Rear)⊙ UJ330A</p> <p><i>Brute Force Greaseable</i> UJ295A</p> <p>Clamp Kit (Rear) UJ492-10</p>	<p>Drive Shaft (2 W/D) (Cont.)</p> <p>U-Joint (Cont.)</p> <p>2007 Silverado & Sierra Classic w/ 6.0L Eng. Exc. Ext. Cab & Long Bed: [Type 2]</p> <p>U-Joint (Front)⊙ UJ330</p> <p><i>Brute Force Greaseable</i> UJ295</p> <p>(For Aluminum Drive Shaft) UJ330C</p> <p>Clamp Kit (Front) UJ492-10</p> <p>U-Joint (Center)⊙ UJ330</p> <p><i>Brute Force Greaseable</i> UJ295</p> <p>(For Aluminum Drive Shaft) UJ330C</p> <p>Clamp Kit (Center) UJ492-10</p> <p>U-Joint (Rear)⊙ UJ330</p> <p><i>Brute Force Greaseable</i> UJ295</p> <p>(For Aluminum Drive Shaft) UJ330C</p> <p>Clamp Kit (Rear) UJ492-10</p> <p style="text-align: right;">(Continued)</p>
---	--

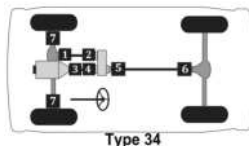
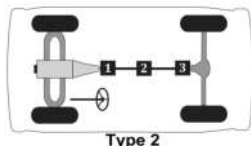

Passenger cars, light & medium trucks

(Cont.) -- Chevrolet/GMC Truck 1 ton

MFG./YEAR	MODEL & LOCATION	PART NO.	MFG./YEAR	MODEL & LOCATION	PART NO.
Drive Shaft (2 W/D) (Cont.)			Drive Shaft (2 W/D) (Cont.)		
U-Joint (Cont.)			U-Joint (Cont.)		
2007	Silverado & Sierra Classic w/ Auto. Trans., 6.6L & 8.1L Eng.s.: [Type 2]		2006-2001	Silverado & Sierra w/ Auto. Trans., 6.6L & 8.1L Eng.s.: [Type 2]	
	U-Joint (Front)Ⓢ	UJ330		U-Joint (Front)Ⓢ	UJ330
	Brute Force Greaseable	UJ295		Brute Force Greaseable	UJ295
	(For Aluminum Drive Shaft)	UJ330C		(For Aluminum Drive Shaft)	UJ330C
	Clamp Kit (Front)	UJ492-10		Clamp Kit (Front)	UJ492-10
	U-Joint (Center)Ⓢ	UJ330		U-Joint (Center)Ⓢ	UJ330
	Brute Force Greaseable	UJ295		Brute Force Greaseable	UJ295
	(For Aluminum Drive Shaft)	UJ330C		(For Aluminum Drive Shaft)	UJ330C
	Clamp Kit (Center)	UJ492-10		Clamp Kit (Center)	UJ492-10
	U-Joint (Rear)Ⓢ	UJ330		U-Joint (Rear)Ⓢ	UJ330
	Brute Force Greaseable	UJ295		Brute Force Greaseable	UJ295
	(For Aluminum Drive Shaft)	UJ330C		(For Aluminum Drive Shaft)	UJ330C
	Clamp Kit (Rear)	UJ492-10		Clamp Kit (Rear)	UJ492-10
2007	Silverado & Sierra Classic w/ Man. Trans., 6.6L & 8.1L Eng.s.: [Type 2]		2006-2001	Silverado & Sierra w/ Man. Trans., 6.6L & 8.1L Eng.s.: [Type 2]	
	U-Joint (Front)Ⓢ	UJ351		U-Joint (Front)Ⓢ	UJ351
	(For Aluminum Drive Shaft)	UJ351C		(For Aluminum Drive Shaft)	UJ351C
	Brute Force Non Greaseable	UJ351BF		Brute Force Non Greaseable	UJ351BF
	U-Joint (Center)Ⓢ	UJ351		U-Joint (Center)Ⓢ	UJ351
	(For Aluminum Drive Shaft)	UJ351C		(For Aluminum Drive Shaft)	UJ351C
	Brute Force Non Greaseable	UJ351BF		Brute Force Non Greaseable	UJ351BF
	U-Joint (Rear)Ⓢ	UJ351		U-Joint (Rear)Ⓢ	UJ351
	(For Aluminum Drive Shaft)	UJ351C		(For Aluminum Drive Shaft)	UJ351C
	Brute Force Non Greaseable	UJ351BF		Brute Force Non Greaseable	UJ351BF
2006-2001	Silverado & Sierra w/ 6.0L Eng., Ext. Cab & Long Bed: [Type 2]		2002-1997	Cab & Chassis w/ 135" & 160" Wheel Base: [Type 2]	
	U-Joint (Front)Ⓢ	UJ330A		U-Joint (Front)Ⓢ	UJ330
	Brute Force Greaseable	UJ295A		Brute Force Greaseable	UJ295
	Clamp Kit (Front)	UJ492-10		(For Aluminum Drive Shaft)	UJ330C
	U-Joint (Center)Ⓢ	UJ330A		Clamp Kit (Front)	UJ331-10
	Brute Force Greaseable	UJ295A		U-Joint (Center)Ⓢ	UJ330
	Clamp Kit (Center)	UJ492-10		Brute Force Greaseable	UJ295
	U-Joint (Rear)Ⓢ	UJ330A		(For Aluminum Drive Shaft)	UJ330C
	Brute Force Greaseable	UJ295A		Clamp Kit (Center)	UJ331-10
	Clamp Kit (Rear)	UJ492-10		U-Joint (Rear)Ⓢ	UJ330
2006-2001	Silverado & Sierra w/ 6.0L Eng. Exc. Ext. Cab & Long Bed: [Type 2]			Brute Force Greaseable	UJ295
	U-Joint (Front)Ⓢ	UJ330		(For Aluminum Drive Shaft)	UJ330C
	Brute Force Greaseable	UJ295		Clamp Kit (Rear)	UJ331-10
	(For Aluminum Drive Shaft)	UJ330C			(Continued)
	Clamp Kit (Front)	UJ492-10			
	U-Joint (Center)Ⓢ	UJ330			
	Brute Force Greaseable	UJ295			
	(For Aluminum Drive Shaft)	UJ330C			
	Clamp Kit (Center)	UJ492-10			
	U-Joint (Rear)Ⓢ	UJ330			
	Brute Force Greaseable	UJ295			
	(For Aluminum Drive Shaft)	UJ330C			
	Clamp Kit (Rear)	UJ492-10			

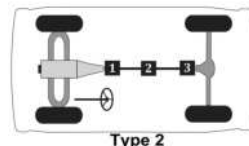

Passenger cars, light & medium trucks

Chevrolet/GMC Truck 1 ton -- (Cont.)

MFG./YEAR	MODEL & LOCATION	PART NO.	MFG./YEAR	MODEL & LOCATION	PART NO.
Drive Shaft (2 W/D) (Cont.)			Drive Shaft (2 W/D) (Cont.)		
U-Joint (Cont.)			U-Joint (Cont.)		
2002-1991 Cab & Chassis w/ 185" Wheel Base:			1978-1976 Crew Cab: [Type 2]		
[Type 3]			U-Joint (Front)ⓁUJ331		
U-Joint (Front)ⓁUJ330			<i>Brute Force Greaseable</i>UJ232		
<i>Brute Force Greaseable</i>UJ295			<i>Brute Force Non Greaseable</i>UJ231		
(For Aluminum Drive Shaft)UJ330C			(For Aluminum Drive Shaft)UJ331C		
Clamp Kit (Front)UJ331-10			Clamp Kit (Front)UJ492-10		
U-Joint (Center; Front)ⓈUJ330			U-Joint (Center)ⓈUJ331		
<i>Brute Force Greaseable</i>UJ295			<i>Brute Force Greaseable</i>UJ232		
(For Aluminum Drive Shaft)UJ330C			<i>Brute Force Non Greaseable</i>UJ231		
Clamp Kit (Center; Front)UJ331-10			(For Aluminum Drive Shaft)UJ331C		
U-Joint (Center; Rear)ⓈUJ330			Clamp Kit (Center)UJ492-10		
<i>Brute Force Greaseable</i>UJ295			U-Joint (Rear)ⓈUJ331		
(For Aluminum Drive Shaft)UJ330C			<i>Brute Force Greaseable</i>UJ232		
Clamp Kit (Center; Rear)UJ331-10			<i>Brute Force Non Greaseable</i>UJ231		
U-Joint (Rear)ⓈUJ330			(For Aluminum Drive Shaft)UJ331C		
<i>Brute Force Greaseable</i>UJ295			Clamp Kit (Rear)UJ492-10		
(For Aluminum Drive Shaft)UJ330C			1978-1976 3 Spd. Man. Trans. & THM350 Auto.		
Clamp Kit (Rear)UJ331-10			Trans. Exc. Crew Cab: [Type 2]		
2000-1991 C3500: [Type 2]			U-Joint (Front)ⓁUJ369		
U-Joint (Front)ⓁUJ331			<i>Brute Force Greaseable</i>UJ280		
<i>Brute Force Greaseable</i>UJ232			<i>Brute Force Non Greaseable</i>UJ269		
<i>Brute Force Non Greaseable</i>UJ231			(For Aluminum Drive Shaft)UJ369C		
(For Aluminum Drive Shaft)UJ331C			U-Joint (Center)ⓈUJ369		
Clamp Kit (Front)UJ492-10			<i>Brute Force Greaseable</i>UJ280		
U-Joint (Center)ⓈUJ331			<i>Brute Force Non Greaseable</i>UJ269		
<i>Brute Force Greaseable</i>UJ232			(For Aluminum Drive Shaft)UJ369C		
<i>Brute Force Non Greaseable</i>UJ231			U-Joint (Rear)ⓈUJ331		
(For Aluminum Drive Shaft)UJ331C			<i>Brute Force Greaseable</i>UJ232		
Clamp Kit (Center)UJ492-10			<i>Brute Force Non Greaseable</i>UJ231		
U-Joint (Rear)ⓈUJ331			(For Aluminum Drive Shaft)UJ331C		
<i>Brute Force Greaseable</i>UJ232			Clamp Kit (Rear)UJ492-10		
<i>Brute Force Non Greaseable</i>UJ231			1978-1976 4 Spd. Man. Trans. & THM400 Auto.		
(For Aluminum Drive Shaft)UJ331C			Trans. Exc. Crew Cab: [Type 2]		
Clamp Kit (Rear)UJ492-10			U-Joint (Front)ⓁUJ331		
1990-1979 All: [Type 2]			<i>Brute Force Greaseable</i>UJ232		
U-Joint (Front)ⓁUJ331			<i>Brute Force Non Greaseable</i>UJ231		
<i>Brute Force Greaseable</i>UJ232			(For Aluminum Drive Shaft)UJ331C		
<i>Brute Force Non Greaseable</i>UJ231			Clamp Kit (Front)UJ492-10		
(For Aluminum Drive Shaft)UJ331C			U-Joint (Center)ⓈUJ331		
Clamp Kit (Front)UJ492-10			<i>Brute Force Greaseable</i>UJ232		
U-Joint (Center)ⓈUJ331			<i>Brute Force Non Greaseable</i>UJ231		
<i>Brute Force Greaseable</i>UJ232			(For Aluminum Drive Shaft)UJ331C		
<i>Brute Force Non Greaseable</i>UJ231			Clamp Kit (Center)UJ492-10		
(For Aluminum Drive Shaft)UJ331C			U-Joint (Rear)ⓈUJ331		
Clamp Kit (Center)UJ492-10			<i>Brute Force Greaseable</i>UJ232		
U-Joint (Rear)ⓈUJ331			<i>Brute Force Non Greaseable</i>UJ231		
<i>Brute Force Greaseable</i>UJ232			(For Aluminum Drive Shaft)UJ331C		
<i>Brute Force Non Greaseable</i>UJ231			Clamp Kit (Rear)UJ492-10		
(For Aluminum Drive Shaft)UJ331C					
Clamp Kit (Rear)UJ492-10					

(Continued)

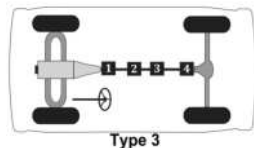
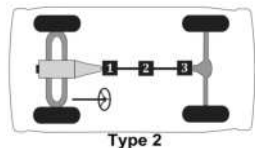

Passenger cars, light & medium trucks

(Cont.) -- Chevrolet/GMC Truck 1 ton

MFG./YEAR	MODEL & LOCATION	PART NO.	MFG./YEAR	MODEL & LOCATION	PART NO.
Drive Shaft (2 W/D) (Cont.)			Drive Shaft (2 W/D) (Cont.)		
U-Joint (Cont.)			U-Joint (Cont.)		
1975-1973 Crew Cab: [Type 2]			1972-1968 Auto. Trans. Exc. 396 Eng.: [Type 2]		
	U-Joint (Front)Ⓢ	UJ331		U-Joint (Front)Ⓢ	UJ369
	<i>Brute Force Greaseable</i>	UJ232		<i>Brute Force Greaseable</i>	UJ280
	<i>Brute Force Non Greaseable</i>	UJ231		<i>Brute Force Non Greaseable</i>	UJ269
	(For Aluminum Drive Shaft)	UJ331C		(For Aluminum Drive Shaft)	UJ369C
	U-Bolt Kit (Front)	UJ330-10		U-Joint (Center)Ⓢ	UJ331
	U-Joint (Center)Ⓢ	UJ331		<i>Brute Force Greaseable</i>	UJ232
	<i>Brute Force Greaseable</i>	UJ232		<i>Brute Force Non Greaseable</i>	UJ231
	<i>Brute Force Non Greaseable</i>	UJ231		(For Aluminum Drive Shaft)	UJ331C
	(For Aluminum Drive Shaft)	UJ331C		U-Bolt Kit (Center)	UJ330-10
	U-Bolt Kit (Center)	UJ330-10		U-Joint (Rear)Ⓢ	UJ331
	U-Joint (Rear)Ⓢ	UJ331		<i>Brute Force Greaseable</i>	UJ232
	<i>Brute Force Greaseable</i>	UJ232		<i>Brute Force Non Greaseable</i>	UJ231
	<i>Brute Force Non Greaseable</i>	UJ231		(For Aluminum Drive Shaft)	UJ331C
	(For Aluminum Drive Shaft)	UJ331C		U-Bolt Kit (Rear)	UJ330-10
	U-Bolt Kit (Rear)	UJ330-10		1972-1960 Man. Trans.: [Type 2]	
	1975-1973 3 Spd. Man. Trans. & THM350 Auto.			U-Joint (Front)Ⓢ	UJ331
	Trans. Exc. Crew Cab: [Type 2]			<i>Brute Force Greaseable</i>	UJ232
	U-Joint (Front)Ⓢ	UJ369		<i>Brute Force Non Greaseable</i>	UJ231
	<i>Brute Force Greaseable</i>	UJ280		(For Aluminum Drive Shaft)	UJ331C
	<i>Brute Force Non Greaseable</i>	UJ269		U-Bolt Kit (Front)	UJ330-10
	(For Aluminum Drive Shaft)	UJ369C		U-Joint (Center)Ⓢ	UJ331
	U-Joint (Center)Ⓢ	UJ369		<i>Brute Force Greaseable</i>	UJ232
	<i>Brute Force Greaseable</i>	UJ280		<i>Brute Force Non Greaseable</i>	UJ231
	<i>Brute Force Non Greaseable</i>	UJ269		(For Aluminum Drive Shaft)	UJ331C
	(For Aluminum Drive Shaft)	UJ369C		U-Bolt Kit (Center)	UJ330-10
	U-Joint (Rear)Ⓢ	UJ331		U-Joint (Rear)Ⓢ	UJ331
	<i>Brute Force Greaseable</i>	UJ232		<i>Brute Force Greaseable</i>	UJ232
	<i>Brute Force Non Greaseable</i>	UJ231		<i>Brute Force Non Greaseable</i>	UJ231
	(For Aluminum Drive Shaft)	UJ331C		(For Aluminum Drive Shaft)	UJ331C
	U-Bolt Kit (Rear)	UJ330-10		U-Bolt Kit (Rear)	UJ330-10
	1975-1973 4 Spd. Man. Trans. & THM400 Auto.			1969-1968 Auto. Trans. w/ 396 Eng.: [Type 2]	
	Trans. Exc. Crew Cab: [Type 2]			U-Joint (Front)Ⓢ	UJ354
	U-Joint (Front)Ⓢ	UJ331		<i>Brute Force Greaseable</i>	UJ270
	<i>Brute Force Greaseable</i>	UJ232		<i>Brute Force Non Greaseable</i>	UJ254
	<i>Brute Force Non Greaseable</i>	UJ231		(For Aluminum Drive Shaft)	UJ354C
	(For Aluminum Drive Shaft)	UJ331C		U-Joint (Center)Ⓢ	UJ331
	U-Bolt Kit (Front)	UJ330-10		<i>Brute Force Greaseable</i>	UJ232
	U-Joint (Center)Ⓢ	UJ331		<i>Brute Force Non Greaseable</i>	UJ231
	<i>Brute Force Greaseable</i>	UJ232		(For Aluminum Drive Shaft)	UJ331C
	<i>Brute Force Non Greaseable</i>	UJ231		U-Bolt Kit (Center)	UJ330-10
	(For Aluminum Drive Shaft)	UJ331C		U-Joint (Rear)Ⓢ	UJ331
	U-Bolt Kit (Center)	UJ330-10		<i>Brute Force Greaseable</i>	UJ232
	U-Joint (Rear)Ⓢ	UJ331		<i>Brute Force Non Greaseable</i>	UJ231
	<i>Brute Force Greaseable</i>	UJ232		(For Aluminum Drive Shaft)	UJ331C
	<i>Brute Force Non Greaseable</i>	UJ231		U-Bolt Kit (Rear)	UJ330-10
	(For Aluminum Drive Shaft)	UJ331C			(Continued)
	U-Bolt Kit (Rear)	UJ330-10			

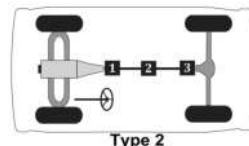

Passenger cars, light & medium trucks

Chevrolet/GMC Truck 1 ton -- (Cont.)

MFG./YEAR	MODEL & LOCATION	PART NO.	MFG./YEAR	MODEL & LOCATION	PART NO.
Drive Shaft (2 W/D) (Cont.)			Drive Shaft (4 W/D) (Cont.)		
U-Joint (Cont.)			U-Joint (Cont.)		
1967-1960 Auto. Trans.: [Type 2]			2016-2007 Silverado & Sierra HD w/ 3 Joint		
U-Joint (Front)Ⓚ			Shaft: [Type 14]		
Brute Force Greaseable UJ369			U-Joint (Frnt. Shaft; Frt.)Ⓚ UJ534G		
Brute Force Non Greaseable UJ280			Brute Force Greaseable UJ235		
(For Aluminum Drive Shaft) UJ369C			Brute Force Non Greaseable UJ234		
U-Joint (Center)Ⓚ UJ331			Clamp Kit (Frnt. Shaft; Frt.) UJ530-10		
Brute Force Greaseable UJ232			U-Joint (Frnt. Shaft; Rr.)Ⓚ UJ534G		
Brute Force Non Greaseable UJ231			Brute Force Greaseable UJ235		
(For Aluminum Drive Shaft) UJ331C			Brute Force Non Greaseable UJ234		
U-Bolt Kit (Center) UJ330-10			Clamp Kit (Frnt. Shaft; Rr.) UJ530-10		
U-Joint (Rear)Ⓚ UJ331			U-Joint (Rr. Shaft; Frt.)Ⓚ UJ351A		
Brute Force Greaseable UJ232			Brute Force Non Greaseable UJ351ABF		
Brute Force Non Greaseable UJ231			U-Joint (Rr. Shaft; Ctr.)Ⓚ UJ351A		
(For Aluminum Drive Shaft) UJ331C			Brute Force Non Greaseable UJ351ABF		
U-Bolt Kit (Rear) UJ330-10			U-Joint (Rr. Shaft; Rr.)Ⓚ UJ351A		
			Brute Force Non Greaseable UJ351ABF		
Drive Shaft (4 W/D)			2007 Silverado & Sierra Classic w/ Reg.		
U-Joint			Cab & 4 Spd. Auto. Trans.: [Type 13]		
2016 Suburban 3500HD: [Type 13]			U-Joint (Frnt. Shaft; Frt.)Ⓚ UJ534G		
U-Joint (Frnt. Shaft; Frt.)Ⓚ UJ534G			Brute Force Greaseable UJ235		
Brute Force Greaseable UJ235			Brute Force Non Greaseable UJ234		
Brute Force Non Greaseable UJ234			Clamp Kit (Frnt. Shaft; Frt.) UJ530-10		
Clamp Kit (Frnt. Shaft; Frt.) UJ530-10			U-Joint (Frnt. Shaft; Rr.)Ⓚ UJ534G		
U-Joint (Frnt. Shaft; Rr.)Ⓚ UJ534G			Brute Force Greaseable UJ235		
Brute Force Greaseable UJ235			Brute Force Non Greaseable UJ234		
Brute Force Non Greaseable UJ234			Clamp Kit (Frnt. Shaft; Rr.) UJ530-10		
Clamp Kit (Frnt. Shaft; Rr.) UJ530-10			U-Joint (Rr. Shaft; Frt.)Ⓚ UJ330A		
2016-2007 Silverado & Sierra HD w/ 2 Joint			Brute Force Greaseable UJ295A		
Shaft: [Type 13]			Clamp Kit (Rr. Shaft; Frt.) UJ492-10		
U-Joint (Frnt. Shaft; Frt.)Ⓚ UJ534G			U-Joint (Rr. Shaft; Rr.)Ⓚ UJ330A		
Brute Force Greaseable UJ235			Brute Force Greaseable UJ295A		
Brute Force Non Greaseable UJ234			Brute Force Greaseable UJ295A		
Clamp Kit (Frnt. Shaft; Frt.) UJ530-10			Clamp Kit (Rr. Shaft; Rr.) UJ492-10		
U-Joint (Frnt. Shaft; Rr.)Ⓚ UJ534G			2007 Silverado & Sierra Classic w/ Reg.		
Brute Force Greaseable UJ235			Cab & 5 Spd. Man. Trans.: [Type 13]		
Brute Force Non Greaseable UJ234			U-Joint (Frnt. Shaft; Frt.)Ⓚ UJ534G		
Clamp Kit (Frnt. Shaft; Rr.) UJ530-10			Brute Force Greaseable UJ235		
U-Joint (Rr. Shaft; Frt.)Ⓚ UJ351A			Brute Force Non Greaseable UJ234		
Brute Force Non Greaseable UJ351ABF			Clamp Kit (Frnt. Shaft; Frt.) UJ530-10		
U-Joint (Rr. Shaft; Rr.)Ⓚ UJ351A			U-Joint (Frnt. Shaft; Rr.)Ⓚ UJ534G		
Brute Force Non Greaseable UJ351ABF			Brute Force Greaseable UJ235		
			Brute Force Non Greaseable UJ234		
			Clamp Kit (Frnt. Shaft; Rr.) UJ530-10		
			U-Joint (Rr. Shaft; Frt.)Ⓚ UJ330A		
			Brute Force Greaseable UJ295A		
			Clamp Kit (Rr. Shaft; Frt.) UJ492-10		
			U-Joint (Rr. Shaft; Rr.)Ⓚ UJ330A		
			Brute Force Greaseable UJ295A		
			Clamp Kit (Rr. Shaft; Rr.) UJ492-10		

(Continued)

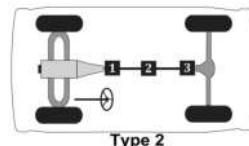
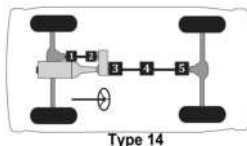
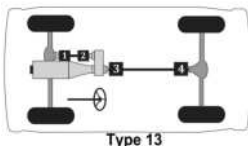

Passenger cars, light & medium trucks

(Cont.) -- Chevrolet/GMC Truck 1 ton

MFG./YEAR	MODEL & LOCATION	PART NO.	MFG./YEAR	MODEL & LOCATION	PART NO.
Drive Shaft (4 W/D) (Cont.)			Drive Shaft (4 W/D) (Cont.)		
U-Joint (Cont.)			U-Joint (Cont.)		
2007	Silverado & Sierra Classic w/ Reg. Cab & 6 Spd. Auto. Trans.: [Type 14]		2007	Silverado & Sierra Classic w/ Ext. Cab & Auto. Trans.: [Type 13]	
	U-Joint (Frnt. Shaft; Frt.) ^①	UJ534G		U-Joint (Frnt. Shaft; Frt.) ^①	UJ534G
	Brute Force Greaseable	UJ235		Brute Force Greaseable	UJ235
	Brute Force Non Greaseable	UJ234		Brute Force Non Greaseable	UJ234
	Clamp Kit (Frnt. Shaft; Frt.)	UJ530-10		Clamp Kit (Frnt. Shaft; Frt.)	UJ530-10
	U-Joint (Frnt. Shaft; Rr.) ^②	UJ534G		U-Joint (Frnt. Shaft; Rr.) ^②	UJ534G
	Brute Force Greaseable	UJ235		Brute Force Greaseable	UJ235
	Brute Force Non Greaseable	UJ234		Brute Force Non Greaseable	UJ234
	Clamp Kit (Frnt. Shaft; Rr.)	UJ530-10		Clamp Kit (Frnt. Shaft; Rr.)	UJ530-10
	U-Joint (Rr. Shaft; Frt.) ^③	UJ351		U-Joint (Rr. Shaft; Frt.) ^③	UJ330
	(For Aluminum Drive Shaft)	UJ351C		Brute Force Greaseable	UJ295
	Brute Force Non Greaseable	UJ351BF		(For Aluminum Drive Shaft)	UJ330C
	U-Joint (Rr. Shaft; Ctr.) ^④	UJ351		Clamp Kit (Rr. Shaft; Frt.)	UJ492-10
	(For Aluminum Drive Shaft)	UJ351C		U-Joint (Rr. Shaft; Rr.) ^⑤	UJ330
	Brute Force Non Greaseable	UJ351BF		Brute Force Greaseable	UJ295
	U-Joint (Rr. Shaft; Rr.) ^⑥	UJ351		(For Aluminum Drive Shaft)	UJ330C
	(For Aluminum Drive Shaft)	UJ351C		Clamp Kit (Rr. Shaft; Rr.)	UJ492-10
	Brute Force Non Greaseable	UJ351BF	2007	Silverado & Sierra Classic w/ Ext. Cab & Man. Trans.: [Type 14]	
2007	Silverado & Sierra Classic w/ Crew Cab: [Type 14]			U-Joint (Frnt. Shaft; Frt.) ^①	UJ534G
	U-Joint (Frnt. Shaft; Frt.) ^①	UJ534G		Brute Force Greaseable	UJ235
	Brute Force Greaseable	UJ235		Brute Force Non Greaseable	UJ234
	Brute Force Non Greaseable	UJ234		Clamp Kit (Frnt. Shaft; Frt.)	UJ530-10
	Clamp Kit (Frnt. Shaft; Frt.)	UJ530-10		U-Joint (Frnt. Shaft; Rr.) ^②	UJ534G
	U-Joint (Frnt. Shaft; Rr.) ^②	UJ534G		Brute Force Greaseable	UJ235
	Brute Force Greaseable	UJ235		Brute Force Non Greaseable	UJ234
	Brute Force Non Greaseable	UJ234		Clamp Kit (Frnt. Shaft; Rr.)	UJ530-10
	Clamp Kit (Frnt. Shaft; Rr.)	UJ530-10		U-Joint (Rr. Shaft; Frt.) ^③	UJ330
	U-Joint (Rr. Shaft; Frt.) ^③	UJ330		Brute Force Greaseable	UJ295
	Brute Force Greaseable	UJ295		(For Aluminum Drive Shaft)	UJ330C
	(For Aluminum Drive Shaft)	UJ330C		Clamp Kit (Rr. Shaft; Frt.)	UJ492-10
	Clamp Kit (Rr. Shaft; Frt.)	UJ492-10		U-Joint (Rr. Shaft; Ctr.) ^④	UJ330
	U-Joint (Rr. Shaft; Ctr.) ^④	UJ330		Brute Force Greaseable	UJ295
	Brute Force Greaseable	UJ295		(For Aluminum Drive Shaft)	UJ330C
	(For Aluminum Drive Shaft)	UJ330C		Clamp Kit (Rr. Shaft; Ctr.)	UJ492-10
	Clamp Kit (Rr. Shaft; Ctr.)	UJ492-10		U-Joint (Rr. Shaft; Rr.) ^⑤	UJ330
	U-Joint (Rr. Shaft; Rr.) ^⑤	UJ330		Brute Force Greaseable	UJ295
	Brute Force Greaseable	UJ295		(For Aluminum Drive Shaft)	UJ330C
	(For Aluminum Drive Shaft)	UJ330C		Clamp Kit (Rr. Shaft; Rr.)	UJ492-10
	Clamp Kit (Rr. Shaft; Rr.)	UJ492-10			(Continued)

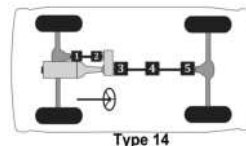
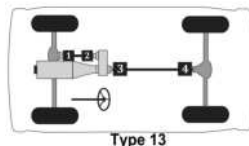

Passenger cars, light & medium trucks

Chevrolet/GMC Truck 1 ton -- (Cont.)

MFG./YEAR	MODEL & LOCATION	PART NO.	MFG./YEAR	MODEL & LOCATION	PART NO.
Drive Shaft (4 W/D) (Cont.)			Drive Shaft (4 W/D) (Cont.)		
U-Joint (Cont.)			U-Joint (Cont.)		
2007	Silverado & Sierra Classic Cab & Chassis w/ 137" WB & 4 Spd. Auto. Trans.: [Type 13]		2007	Silverado & Sierra Classic Cab & Chassis w/ 137" WB & Man. Trans.: [Type 13]	
	U-Joint (Frt. Shaft; Frt.) [⊙]	UJ534G		U-Joint (Frt. Shaft; Frt.) [⊙]	UJ534G
	Brute Force Greaseable	UJ235		Brute Force Greaseable	UJ235
	Brute Force Non Greaseable	UJ234		Brute Force Non Greaseable	UJ234
	Clamp Kit (Frt. Shaft; Frt.)	UJ530-10		Clamp Kit (Frt. Shaft; Frt.)	UJ530-10
	U-Joint (Frt. Shaft; Rr.) [⊙]	UJ534G		U-Joint (Frt. Shaft; Rr.) [⊙]	UJ534G
	Brute Force Greaseable	UJ235		Brute Force Greaseable	UJ235
	Brute Force Non Greaseable	UJ234		Brute Force Non Greaseable	UJ234
	Clamp Kit (Frt. Shaft; Rr.)	UJ530-10		Clamp Kit (Frt. Shaft; Rr.)	UJ530-10
	U-Joint (Rr. Shaft; Frt.) [⊙]	UJ330		U-Joint (Rr. Shaft; Frt.) [⊙]	UJ330
	Brute Force Greaseable	UJ295		Brute Force Greaseable	UJ295
	(For Aluminum Drive Shaft)	UJ330C		(For Aluminum Drive Shaft)	UJ330C
	Clamp Kit (Rr. Shaft; Frt.)	UJ492-10		Clamp Kit (Rr. Shaft; Frt.)	UJ492-10
	U-Joint (Rr. Shaft; Rr.) [⊙]	UJ330		U-Joint (Rr. Shaft; Rr.) [⊙]	UJ330
	Brute Force Greaseable	UJ295		Brute Force Greaseable	UJ295
	(For Aluminum Drive Shaft)	UJ330C		(For Aluminum Drive Shaft)	UJ330C
	Clamp Kit (Rr. Shaft; Rr.)	UJ492-10		Clamp Kit (Rr. Shaft; Rr.)	UJ492-10
2007	Silverado & Sierra Classic Cab & Chassis w/ 137" WB & 6 Spd. Auto. Trans.: [Type 13]		2007	Silverado & Sierra Classic Cab & Chassis w/ 161.5" WB & 4 Spd. Auto. Trans.: [Type 14]	
	U-Joint (Frt. Shaft; Frt.) [⊙]	UJ534G		U-Joint (Frt. Shaft; Frt.) [⊙]	UJ534G
	Brute Force Greaseable	UJ235		Brute Force Greaseable	UJ235
	Brute Force Non Greaseable	UJ234		Brute Force Non Greaseable	UJ234
	Clamp Kit (Frt. Shaft; Frt.)	UJ530-10		Clamp Kit (Frt. Shaft; Frt.)	UJ530-10
	U-Joint (Frt. Shaft; Rr.) [⊙]	UJ534G		U-Joint (Frt. Shaft; Rr.) [⊙]	UJ534G
	Brute Force Greaseable	UJ235		Brute Force Greaseable	UJ235
	Brute Force Non Greaseable	UJ234		Brute Force Non Greaseable	UJ234
	Clamp Kit (Frt. Shaft; Rr.)	UJ530-10		Clamp Kit (Frt. Shaft; Rr.)	UJ530-10
	U-Joint (Rr. Shaft; Frt.) [⊙]	UJ351		U-Joint (Rr. Shaft; Frt.) [⊙]	UJ330
	(For Aluminum Drive Shaft)	UJ351C		Brute Force Greaseable	UJ295
	Brute Force Non Greaseable	UJ351BF		(For Aluminum Drive Shaft)	UJ330C
	U-Joint (Rr. Shaft; Rr.) [⊙]	UJ351		Clamp Kit (Rr. Shaft; Frt.)	UJ492-10
	(For Aluminum Drive Shaft)	UJ351C		U-Joint (Rr. Shaft; Ctr.) [⊙]	UJ330
	Brute Force Non Greaseable	UJ351BF		Brute Force Greaseable	UJ295
				(For Aluminum Drive Shaft)	UJ330C
				Clamp Kit (Rr. Shaft; Ctr.)	UJ492-10
				U-Joint (Rr. Shaft; Rr.) [⊙]	UJ330
				Brute Force Greaseable	UJ295
				(For Aluminum Drive Shaft)	UJ330C
				Clamp Kit (Rr. Shaft; Rr.)	UJ492-10

(Continued)

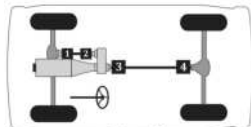

Type 13

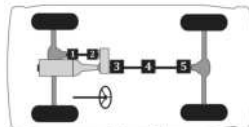

Type 14

200 ▲ For Use w/ 1.063" Bearing Cap Application. ⊙ For Use w/ 1.188" Bearing Cap Application. ◇ For Use w/ Inner Lock Ring Application on Half Shaft. □ For Use w/ Outer Lock Ring Application on Half Shaft.

Passenger cars, light & medium trucks

(Cont.) -- Chevrolet/GMC Truck 1 ton

MFG./YEAR	MODEL & LOCATION	PART NO.	MFG./YEAR	MODEL & LOCATION	PART NO.
Drive Shaft (4 W/D) (Cont.)			Drive Shaft (4 W/D) (Cont.)		
U-Joint (Cont.)			U-Joint (Cont.)		
2007	Silverado & Sierra Classic Cab & Chassis w/ 161.5" WB & 6 Spd. Auto. Trans.: [Type 14]		2006-2005	Silverado & Sierra w/ Reg. Cab & 4 Spd. Auto. Trans.: [Type 13]	
	U-Joint (Frnt. Shaft; Frt.) ①	UJ534G		U-Joint (Frnt. Shaft; Frt.) ①	UJ534G
	<i>Brute Force Greaseable</i>	UJ235		<i>Brute Force Greaseable</i>	UJ235
	<i>Brute Force Non Greaseable</i>	UJ234		<i>Brute Force Non Greaseable</i>	UJ234
	Clamp Kit (Frnt. Shaft; Frt.)	UJ530-10		Clamp Kit (Frnt. Shaft; Frt.)	UJ530-10
	U-Joint (Frnt. Shaft; Rr.) ②	UJ534G		U-Joint (Frnt. Shaft; Rr.) ②	UJ534G
	<i>Brute Force Greaseable</i>	UJ235		<i>Brute Force Greaseable</i>	UJ235
	<i>Brute Force Non Greaseable</i>	UJ234		<i>Brute Force Non Greaseable</i>	UJ234
	Clamp Kit (Frnt. Shaft; Rr.)	UJ530-10		Clamp Kit (Frnt. Shaft; Rr.)	UJ530-10
	U-Joint (Rr. Shaft; Frt.) ③	UJ351		U-Joint (Rr. Shaft; Frt.) ③	UJ330A
	(For Aluminum Drive Shaft)	UJ351C		<i>Brute Force Greaseable</i>	UJ295A
	<i>Brute Force Non Greaseable</i>	UJ351BF		Clamp Kit (Rr. Shaft; Frt.)	UJ492-10
	U-Joint (Rr. Shaft; Ctr.) ④	UJ351		U-Joint (Rr. Shaft; Rr.) ④	UJ330A
	(For Aluminum Drive Shaft)	UJ351C		<i>Brute Force Greaseable</i>	UJ295A
	<i>Brute Force Non Greaseable</i>	UJ351BF		Clamp Kit (Rr. Shaft; Rr.)	UJ492-10
	U-Joint (Rr. Shaft; Rr.) ⑤	UJ351	2006-2005	Silverado & Sierra w/ Reg. Cab, 5 Spd. & 6 Spd. Auto Trans.: [Type 13]	
	(For Aluminum Drive Shaft)	UJ351C		U-Joint (Frnt. Shaft; Frt.) ①	UJ534G
	<i>Brute Force Non Greaseable</i>	UJ351BF		<i>Brute Force Greaseable</i>	UJ235
2007	Silverado & Sierra Classic Cab & Chassis w/ 161.5" WB & Man. Trans.: [Type 14]			<i>Brute Force Non Greaseable</i>	UJ234
	U-Joint (Frnt. Shaft; Frt.) ①	UJ534G		Clamp Kit (Frnt. Shaft; Frt.)	UJ530-10
	<i>Brute Force Greaseable</i>	UJ235		U-Joint (Frnt. Shaft; Rr.) ②	UJ534G
	<i>Brute Force Non Greaseable</i>	UJ234		<i>Brute Force Greaseable</i>	UJ235
	Clamp Kit (Frnt. Shaft; Frt.)	UJ530-10		<i>Brute Force Non Greaseable</i>	UJ234
	U-Joint (Frnt. Shaft; Rr.) ②	UJ534G		Clamp Kit (Frnt. Shaft; Rr.)	UJ530-10
	<i>Brute Force Greaseable</i>	UJ235		U-Joint (Rr. Shaft; Frt.) ③	UJ351
	<i>Brute Force Non Greaseable</i>	UJ234		(For Aluminum Drive Shaft)	UJ351C
	Clamp Kit (Frnt. Shaft; Rr.)	UJ530-10		<i>Brute Force Non Greaseable</i>	UJ351BF
	U-Joint (Rr. Shaft; Frt.) ③	UJ330		U-Joint (Rr. Shaft; Rr.) ④	UJ351
	<i>Brute Force Greaseable</i>	UJ295		(For Aluminum Drive Shaft)	UJ351C
	(For Aluminum Drive Shaft)	UJ330C		<i>Brute Force Non Greaseable</i>	UJ351BF
	Clamp Kit (Rr. Shaft; Frt.)	UJ492-10	2006-2005	Silverado & Sierra w/ Reg. Cab & 5 Spd. Man. Trans.: [Type 13]	
	U-Joint (Rr. Shaft; Ctr.) ④	UJ330		U-Joint (Frnt. Shaft; Frt.) ①	UJ534G
	<i>Brute Force Greaseable</i>	UJ295		<i>Brute Force Greaseable</i>	UJ235
	(For Aluminum Drive Shaft)	UJ330C		<i>Brute Force Non Greaseable</i>	UJ234
	Clamp Kit (Rr. Shaft; Ctr.)	UJ492-10		Clamp Kit (Frnt. Shaft; Frt.)	UJ530-10
	U-Joint (Rr. Shaft; Rr.) ⑤	UJ330		U-Joint (Frnt. Shaft; Rr.) ②	UJ534G
	<i>Brute Force Greaseable</i>	UJ295		<i>Brute Force Greaseable</i>	UJ235
	(For Aluminum Drive Shaft)	UJ330C		<i>Brute Force Non Greaseable</i>	UJ234
	Clamp Kit (Rr. Shaft; Rr.)	UJ492-10		Clamp Kit (Frnt. Shaft; Rr.)	UJ530-10
				U-Joint (Rr. Shaft; Frt.) ③	UJ330A
				<i>Brute Force Greaseable</i>	UJ295A
				Clamp Kit (Rr. Shaft; Frt.)	UJ492-10
				U-Joint (Rr. Shaft; Rr.) ④	UJ330A
				<i>Brute Force Greaseable</i>	UJ295A
				Clamp Kit (Rr. Shaft; Rr.)	UJ492-10

(Continued)

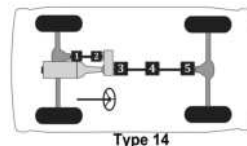
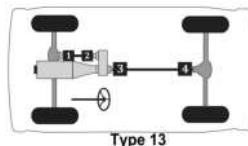

Passenger cars, light & medium trucks

Chevrolet/GMC Truck 1 ton -- (Cont.)

MFG./YEAR	MODEL & LOCATION	PART NO.	MFG./YEAR	MODEL & LOCATION	PART NO.
-----------	------------------	----------	-----------	------------------	----------

Drive Shaft (4 W/D) (Cont.)

U-Joint (Cont.)

2006-2005 Silverado & Sierra w/ Reg. Cab & 6

Spd. Man. Trans.: [Type 14]

U-Joint (Fr. Shaft; Frt.)⊙	UJ534G
Brute Force Greaseable	UJ235
Brute Force Non Greaseable	UJ234
Clamp Kit (Fr. Shaft; Frt.)	UJ530-10
U-Joint (Fr. Shaft; Rr.)⊙	UJ534G
Brute Force Greaseable	UJ235
Brute Force Non Greaseable	UJ234
Clamp Kit (Fr. Shaft; Rr.)	UJ530-10
U-Joint (Rr. Shaft; Frt.)⊙	UJ351
(For Aluminum Drive Shaft)	UJ351C
Brute Force Non Greaseable	UJ351BF
U-Joint (Rr. Shaft; Ctr.)⊙	UJ351
(For Aluminum Drive Shaft)	UJ351C
Brute Force Non Greaseable	UJ351BF
U-Joint (Rr. Shaft; Rr.)⊙	UJ351
(For Aluminum Drive Shaft)	UJ351C
Brute Force Non Greaseable	UJ351BF

2006-2005 Silverado & Sierra w/ Ext. Cab & Auto.

Trans.: [Type 14]

U-Joint (Fr. Shaft; Frt.)⊙	UJ534G
Brute Force Greaseable	UJ235
Brute Force Non Greaseable	UJ234
Clamp Kit (Fr. Shaft; Frt.)	UJ530-10
U-Joint (Fr. Shaft; Rr.)⊙	UJ534G
Brute Force Greaseable	UJ235
Brute Force Non Greaseable	UJ234
Clamp Kit (Fr. Shaft; Rr.)	UJ530-10
U-Joint (Rr. Shaft; Frt.)⊙	UJ330
Brute Force Greaseable	UJ295
(For Aluminum Drive Shaft)	UJ330C
Clamp Kit (Rr. Shaft; Frt.)	UJ492-10
U-Joint (Rr. Shaft; Ctr.)⊙	UJ330
Brute Force Greaseable	UJ295
(For Aluminum Drive Shaft)	UJ330C
Clamp Kit (Rr. Shaft; Ctr.)	UJ492-10
U-Joint (Rr. Shaft; Rr.)⊙	UJ330
Brute Force Greaseable	UJ295
(For Aluminum Drive Shaft)	UJ330C
Clamp Kit (Rr. Shaft; Rr.)	UJ492-10

Drive Shaft (4 W/D) (Cont.)

U-Joint (Cont.)

2006-2005 Silverado & Sierra w/ Ext. Cab & 5

Spd. Man. Trans.: [Type 14]

U-Joint (Fr. Shaft; Frt.)⊙	UJ534G
Brute Force Greaseable	UJ235
Brute Force Non Greaseable	UJ234
Clamp Kit (Fr. Shaft; Frt.)	UJ530-10
U-Joint (Fr. Shaft; Rr.)⊙	UJ534G
Brute Force Greaseable	UJ235
Brute Force Non Greaseable	UJ234
Clamp Kit (Fr. Shaft; Rr.)	UJ530-10
U-Joint (Rr. Shaft; Frt.)⊙	UJ330
Brute Force Greaseable	UJ295
(For Aluminum Drive Shaft)	UJ330C
Clamp Kit (Rr. Shaft; Frt.)	UJ492-10
U-Joint (Rr. Shaft; Ctr.)⊙	UJ330
Brute Force Greaseable	UJ295
(For Aluminum Drive Shaft)	UJ330C
Clamp Kit (Rr. Shaft; Ctr.)	UJ492-10
U-Joint (Rr. Shaft; Rr.)⊙	UJ330
Brute Force Greaseable	UJ295
(For Aluminum Drive Shaft)	UJ330C
Clamp Kit (Rr. Shaft; Rr.)	UJ492-10

2006-2005 Silverado & Sierra w/ Ext. Cab & 6

Spd. Man. Trans.: [Type 14]

U-Joint (Fr. Shaft; Frt.)⊙	UJ534G
Brute Force Greaseable	UJ235
Brute Force Non Greaseable	UJ234
Clamp Kit (Fr. Shaft; Frt.)	UJ530-10
U-Joint (Fr. Shaft; Rr.)⊙	UJ534G
Brute Force Greaseable	UJ235
Brute Force Non Greaseable	UJ234
Clamp Kit (Fr. Shaft; Rr.)	UJ530-10
U-Joint (Rr. Shaft; Frt.)⊙	UJ351
(For Aluminum Drive Shaft)	UJ351C
Brute Force Non Greaseable	UJ351BF
U-Joint (Rr. Shaft; Ctr.)⊙	UJ351
(For Aluminum Drive Shaft)	UJ351C
Brute Force Non Greaseable	UJ351BF
U-Joint (Rr. Shaft; Rr.)⊙	UJ351
(For Aluminum Drive Shaft)	UJ351C
Brute Force Non Greaseable	UJ351BF

(Continued)

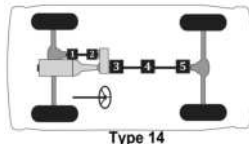

Passenger cars, light & medium trucks

(Cont.) -- Chevrolet/GMC Truck 1 ton

MFG./YEAR	MODEL & LOCATION	PART NO.	MFG./YEAR	MODEL & LOCATION	PART NO.
Drive Shaft (4 W/D) (Cont.)			Drive Shaft (4 W/D) (Cont.)		
U-Joint (Cont.)			U-Joint (Cont.)		
2006-2005 Silverado & Sierra w/ Crew Cab & Auto. Trans.: [Type 14]			2006-2005 Silverado & Sierra w/ Crew Cab & 6 Spd. Man. Trans.: [Type 14]		
	U-Joint (Frt. Shaft; Frt.) ①	UJ534G		U-Joint (Frt. Shaft; Frt.) ①	UJ534G
	<i>Brute Force Greaseable</i>	UJ235		<i>Brute Force Greaseable</i>	UJ235
	<i>Brute Force Non Greaseable</i>	UJ234		<i>Brute Force Non Greaseable</i>	UJ234
	Clamp Kit (Frt. Shaft; Frt.)	UJ530-10		Clamp Kit (Frt. Shaft; Frt.)	UJ530-10
	U-Joint (Frt. Shaft; Rr.) ②	UJ534G		U-Joint (Frt. Shaft; Rr.) ②	UJ534G
	<i>Brute Force Greaseable</i>	UJ235		<i>Brute Force Greaseable</i>	UJ235
	<i>Brute Force Non Greaseable</i>	UJ234		<i>Brute Force Non Greaseable</i>	UJ234
	Clamp Kit (Frt. Shaft; Rr.)	UJ530-10		Clamp Kit (Frt. Shaft; Rr.)	UJ530-10
	U-Joint (Rr. Shaft; Frt.) ③	UJ330		U-Joint (Rr. Shaft; Frt.) ③	UJ351
	<i>Brute Force Greaseable</i>	UJ295		(For Aluminum Drive Shaft)	UJ351C
	(For Aluminum Drive Shaft)	UJ330C		<i>Brute Force Non Greaseable</i>	UJ351BF
	Clamp Kit (Rr. Shaft; Frt.)	UJ492-10		U-Joint (Rr. Shaft; Ctr.) ④	UJ351
	U-Joint (Rr. Shaft; Ctr.) ④	UJ330		(For Aluminum Drive Shaft)	UJ351C
	<i>Brute Force Greaseable</i>	UJ295		<i>Brute Force Non Greaseable</i>	UJ351BF
	(For Aluminum Drive Shaft)	UJ330C		U-Joint (Rr. Shaft; Rr.) ⑤	UJ351
	Clamp Kit (Rr. Shaft; Ctr.)	UJ492-10		(For Aluminum Drive Shaft)	UJ351C
	U-Joint (Rr. Shaft; Rr.) ⑤	UJ330		<i>Brute Force Non Greaseable</i>	UJ351BF
	<i>Brute Force Greaseable</i>	UJ295		2006-2005 Silverado & Sierra Cab & Chassis w/ 137" WB & Auto. Trans.: [Type 13]	
	(For Aluminum Drive Shaft)	UJ330C		U-Joint (Frt. Shaft; Frt.) ①	UJ534G
	Clamp Kit (Rr. Shaft; Rr.)	UJ492-10		<i>Brute Force Greaseable</i>	UJ235
	2006-2005 Silverado & Sierra w/ Crew Cab & 5 Spd. Man. Trans.: [Type 14]			<i>Brute Force Non Greaseable</i>	UJ234
	U-Joint (Frt. Shaft; Frt.) ①	UJ534G		Clamp Kit (Frt. Shaft; Frt.)	UJ530-10
	<i>Brute Force Greaseable</i>	UJ235		U-Joint (Frt. Shaft; Rr.) ②	UJ534G
	<i>Brute Force Non Greaseable</i>	UJ234		<i>Brute Force Greaseable</i>	UJ235
	Clamp Kit (Frt. Shaft; Frt.)	UJ530-10		<i>Brute Force Non Greaseable</i>	UJ234
	U-Joint (Frt. Shaft; Rr.) ②	UJ534G		Clamp Kit (Frt. Shaft; Rr.)	UJ530-10
	<i>Brute Force Greaseable</i>	UJ235		U-Joint (Rr. Shaft; Frt.) ③	UJ330
	<i>Brute Force Non Greaseable</i>	UJ234		<i>Brute Force Greaseable</i>	UJ295
	Clamp Kit (Frt. Shaft; Rr.)	UJ530-10		(For Aluminum Drive Shaft)	UJ330C
	U-Joint (Rr. Shaft; Frt.) ③	UJ330		Clamp Kit (Rr. Shaft; Frt.)	UJ492-10
	<i>Brute Force Greaseable</i>	UJ295		U-Joint (Rr. Shaft; Rr.) ④	UJ330
	(For Aluminum Drive Shaft)	UJ330C		<i>Brute Force Greaseable</i>	UJ295
	Clamp Kit (Rr. Shaft; Frt.)	UJ492-10		(For Aluminum Drive Shaft)	UJ330C
	U-Joint (Rr. Shaft; Ctr.) ④	UJ330		Clamp Kit (Rr. Shaft; Rr.)	UJ492-10
	<i>Brute Force Greaseable</i>	UJ295			(Continued)
	(For Aluminum Drive Shaft)	UJ330C			
	Clamp Kit (Rr. Shaft; Ctr.)	UJ492-10			
	U-Joint (Rr. Shaft; Rr.) ⑤	UJ330			
	<i>Brute Force Greaseable</i>	UJ295			
	(For Aluminum Drive Shaft)	UJ330C			
	Clamp Kit (Rr. Shaft; Rr.)	UJ492-10			

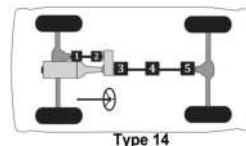
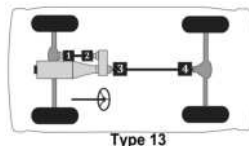

Passenger cars, light & medium trucks

Chevrolet/GMC Truck 1 ton -- (Cont.)

MFG./YEAR	MODEL & LOCATION	PART NO.	MFG./YEAR	MODEL & LOCATION	PART NO.
Drive Shaft (4 W/D) (Cont.)			Drive Shaft (4 W/D) (Cont.)		
U-Joint (Cont.)			U-Joint (Cont.)		
2006-2005 Silverado & Sierra Cab & Chassis w/ 137" WB & 5 Spd. Man. Trans.: [Type 13]			2006-2005 Silverado & Sierra Cab & Chassis w/ 161.5" WB & Auto. Trans.: [Type 14]		
U-Joint (Fr. Shaft; Frt.)⊙		UJ534G	U-Joint (Fr. Shaft; Frt.)⊙		UJ534G
Brute Force Greaseable		UJ235	Brute Force Greaseable		UJ235
Brute Force Non Greaseable		UJ234	Brute Force Non Greaseable		UJ234
Clamp Kit (Fr. Shaft; Frt.)		UJ530-10	Clamp Kit (Fr. Shaft; Frt.)		UJ530-10
U-Joint (Fr. Shaft; Rr.)⊙		UJ534G	U-Joint (Fr. Shaft; Rr.)⊙		UJ534G
Brute Force Greaseable		UJ235	Brute Force Greaseable		UJ235
Brute Force Non Greaseable		UJ234	Brute Force Non Greaseable		UJ234
Clamp Kit (Fr. Shaft; Rr.)		UJ530-10	Clamp Kit (Fr. Shaft; Rr.)		UJ530-10
U-Joint (Rr. Shaft; Frt.)⊙		UJ330	U-Joint (Rr. Shaft; Frt.)⊙		UJ330
Brute Force Greaseable		UJ295	Brute Force Greaseable		UJ295
(For Aluminum Drive Shaft)		UJ330C	(For Aluminum Drive Shaft)		UJ330C
Clamp Kit (Rr. Shaft; Frt.)		UJ492-10	Clamp Kit (Rr. Shaft; Frt.)		UJ492-10
U-Joint (Rr. Shaft; Rr.)⊙		UJ330	U-Joint (Rr. Shaft; Rr.)⊙		UJ330
Brute Force Greaseable		UJ295	Brute Force Greaseable		UJ295
(For Aluminum Drive Shaft)		UJ330C	(For Aluminum Drive Shaft)		UJ330C
Clamp Kit (Rr. Shaft; Rr.)		UJ492-10	Clamp Kit (Rr. Shaft; Rr.)		UJ492-10
2006-2005 Silverado & Sierra Cab & Chassis w/ 137" WB & 6 Spd. Man. Trans.: [Type 13]			2006-2005 Silverado & Sierra Cab & Chassis w/ 161.5" WB & 5 Spd. Man. Trans.: [Type 14]		
U-Joint (Fr. Shaft; Frt.)⊙		UJ534G	U-Joint (Fr. Shaft; Frt.)⊙		UJ534G
Brute Force Greaseable		UJ235	Brute Force Greaseable		UJ235
Brute Force Non Greaseable		UJ234	Brute Force Non Greaseable		UJ234
Clamp Kit (Fr. Shaft; Frt.)		UJ530-10	Clamp Kit (Fr. Shaft; Frt.)		UJ530-10
U-Joint (Fr. Shaft; Rr.)⊙		UJ534G	U-Joint (Fr. Shaft; Rr.)⊙		UJ534G
Brute Force Greaseable		UJ235	Brute Force Greaseable		UJ235
Brute Force Non Greaseable		UJ234	Brute Force Non Greaseable		UJ234
Clamp Kit (Fr. Shaft; Rr.)		UJ530-10	Clamp Kit (Fr. Shaft; Rr.)		UJ530-10
U-Joint (Rr. Shaft; Frt.)⊙		UJ351	U-Joint (Rr. Shaft; Frt.)⊙		UJ351
(For Aluminum Drive Shaft)		UJ351C	(For Aluminum Drive Shaft)		UJ351C
Brute Force Non Greaseable		UJ351BF	Brute Force Non Greaseable		UJ351BF
U-Joint (Rr. Shaft; Rr.)⊙		UJ351	U-Joint (Rr. Shaft; Rr.)⊙		UJ351
(For Aluminum Drive Shaft)		UJ351C	(For Aluminum Drive Shaft)		UJ351C
Brute Force Non Greaseable		UJ351BF	Brute Force Non Greaseable		UJ351BF
			Clamp Kit (Rr. Shaft; Rr.)		UJ492-10
			(Continued)		

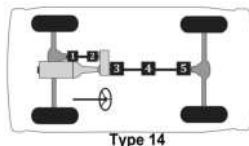
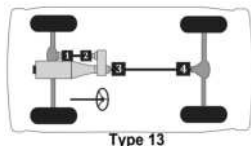

Passenger cars, light & medium trucks

(Cont.) -- Chevrolet/GMC Truck 1 ton

MFG./YEAR	MODEL & LOCATION	PART NO.	MFG./YEAR	MODEL & LOCATION	PART NO.
Drive Shaft (4 W/D) (Cont.)			Drive Shaft (4 W/D) (Cont.)		
U-Joint (Cont.)			U-Joint (Cont.)		
2006-2005 Silverado & Sierra Cab & Chassis w/ 161.5" WB & 6 Spd. Man. Trans.: [Type 14]			2004 Silverado & Sierra w/ Reg. Cab, 5 Spd. Auto Trans. & 1.188" Dia. Rr. Shaft Brg. Caps: [Type 13]		
	U-Joint (Frt. Shaft; Frt.)ⓐ	UJ534G		U-Joint (Frt. Shaft; Frt.)ⓐ	UJ534G
	Brute Force Greaseable	UJ235		Brute Force Greaseable	UJ235
	Brute Force Non Greaseable	UJ234		Brute Force Non Greaseable	UJ234
	Clamp Kit (Frt. Shaft; Frt.)	UJ530-10		Clamp Kit (Frt. Shaft; Frt.)	UJ530-10
	U-Joint (Frt. Shaft; Rr.)ⓑ	UJ534G		U-Joint (Frt. Shaft; Rr.)ⓑ	UJ534G
	Brute Force Greaseable	UJ235		Brute Force Greaseable	UJ235
	Brute Force Non Greaseable	UJ234		Brute Force Non Greaseable	UJ234
	Clamp Kit (Frt. Shaft; Rr.)	UJ530-10		Clamp Kit (Frt. Shaft; Rr.)	UJ530-10
	U-Joint (Rr. Shaft; Frt.)ⓐ	UJ351		U-Joint (Rr. Shaft; Frt.)ⓐ	UJ330
	(For Aluminum Drive Shaft)	UJ351C		Brute Force Greaseable	UJ295
	Brute Force Non Greaseable	UJ351BF		(For Aluminum Drive Shaft)	UJ330C
	U-Joint (Rr. Shaft; Ctr.)ⓐ	UJ351		Clamp Kit (Rr. Shaft; Frt.)	UJ492-10
	(For Aluminum Drive Shaft)	UJ351C		U-Joint (Rr. Shaft; Rr.)ⓑ	UJ330
	Brute Force Non Greaseable	UJ351BF		Brute Force Greaseable	UJ295
	U-Joint (Rr. Shaft; Rr.)ⓑ	UJ351		(For Aluminum Drive Shaft)	UJ330C
	(For Aluminum Drive Shaft)	UJ351C		Clamp Kit (Rr. Shaft; Rr.)	UJ492-10
	Brute Force Non Greaseable	UJ351BF	2004	Silverado & Sierra w/ Reg. Cab, 5 Spd. Auto Trans. & 1.375" Dia. Rr. Shaft Brg. Caps: [Type 13]	
	2004 Silverado & Sierra w/ Reg. Cab & 4 Spd. Auto. Trans.: [Type 13]			U-Joint (Frt. Shaft; Frt.)ⓐ	UJ534G
	U-Joint (Frt. Shaft; Frt.)ⓐ	UJ534G		Brute Force Greaseable	UJ235
	Brute Force Greaseable	UJ235		Brute Force Non Greaseable	UJ234
	Brute Force Non Greaseable	UJ234		Clamp Kit (Frt. Shaft; Frt.)	UJ530-10
	Clamp Kit (Frt. Shaft; Frt.)	UJ530-10		U-Joint (Frt. Shaft; Rr.)ⓑ	UJ534G
	U-Joint (Frt. Shaft; Rr.)ⓑ	UJ534G		Brute Force Greaseable	UJ235
	Brute Force Greaseable	UJ235		Brute Force Non Greaseable	UJ234
	Brute Force Non Greaseable	UJ234		Clamp Kit (Frt. Shaft; Rr.)	UJ530-10
	Clamp Kit (Frt. Shaft; Rr.)	UJ530-10		U-Joint (Rr. Shaft; Frt.)ⓐ	UJ351
	U-Joint (Rr. Shaft; Frt.)ⓐ	UJ330A		(For Aluminum Drive Shaft)	UJ351C
	Brute Force Greaseable	UJ295A		Brute Force Non Greaseable	UJ351BF
	U-Joint (Rr. Shaft; Rr.)ⓑ	UJ330A		U-Joint (Rr. Shaft; Rr.)ⓑ	UJ351
	Brute Force Greaseable	UJ295A		(For Aluminum Drive Shaft)	UJ351C
				Brute Force Non Greaseable	UJ351BF

(Continued)

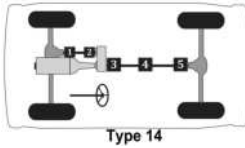
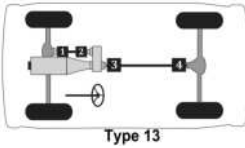

Passenger cars, light & medium trucks

Chevrolet/GMC Truck 1 ton -- (Cont.)

MFG./YEAR	MODEL & LOCATION	PART NO.	MFG./YEAR	MODEL & LOCATION	PART NO.
Drive Shaft (4 W/D) (Cont.)			Drive Shaft (4 W/D) (Cont.)		
U-Joint (Cont.)			U-Joint (Cont.)		
2004	Silverado & Sierra w/ Reg. Cab & 5 Spd. Man. Trans.: [Type 13]		2004	Silverado & Sierra w/ Ext. Cab, 5 Spd. Auto. Trans. & 1.375" Dia. Rr. Shaft Brg. Caps: [Type 13]	
	U-Joint (Fr. Shaft; Frt.)⊙	UJ534G		U-Joint (Fr. Shaft; Frt.)⊙	UJ534G
	Brute Force Greaseable	UJ235		Brute Force Greaseable	UJ235
	Brute Force Non Greaseable	UJ234		Brute Force Non Greaseable	UJ234
	Clamp Kit (Fr. Shaft; Frt.)	UJ530-10		Clamp Kit (Fr. Shaft; Frt.)	UJ530-10
	U-Joint (Fr. Shaft; Rr.)⊙	UJ534G		U-Joint (Fr. Shaft; Rr.)⊙	UJ534G
	Brute Force Greaseable	UJ235		Brute Force Greaseable	UJ235
	Brute Force Non Greaseable	UJ234		Brute Force Non Greaseable	UJ234
	Clamp Kit (Fr. Shaft; Rr.)	UJ530-10		Clamp Kit (Fr. Shaft; Rr.)	UJ530-10
	U-Joint (Rr. Shaft; Frt.)⊙	UJ330A		U-Joint (Rr. Shaft; Frt.)⊙	UJ351
	Brute Force Greaseable	UJ295A		(For Aluminum Drive Shaft)	UJ351C
	Clamp Kit (Rr. Shaft; Frt.)	UJ492-10		Brute Force Non Greaseable	UJ351BF
	U-Joint (Rr. Shaft; Rr.)⊙	UJ330A		U-Joint (Rr. Shaft; Rr.)⊙	UJ351
	Brute Force Greaseable	UJ295A		(For Aluminum Drive Shaft)	UJ351C
	Clamp Kit (Rr. Shaft; Rr.)	UJ492-10		Brute Force Non Greaseable	UJ351BF
2004	Silverado & Sierra w/ Reg. Cab & 6 Spd. Man. Trans.: [Type 13]		2004-2001	Silverado & Sierra w/ Ext. Cab & 4 Spd. Auto. Trans.: [Type 13]	
	U-Joint (Fr. Shaft; Frt.)⊙	UJ534G		U-Joint (Fr. Shaft; Frt.)⊙	UJ534G
	Brute Force Greaseable	UJ235		Brute Force Greaseable	UJ235
	Brute Force Non Greaseable	UJ234		Brute Force Non Greaseable	UJ234
	Clamp Kit (Fr. Shaft; Frt.)	UJ530-10		Clamp Kit (Fr. Shaft; Frt.)	UJ530-10
	U-Joint (Fr. Shaft; Rr.)⊙	UJ534G		U-Joint (Fr. Shaft; Rr.)⊙	UJ534G
	Brute Force Greaseable	UJ235		Brute Force Greaseable	UJ235
	Brute Force Non Greaseable	UJ234		Brute Force Non Greaseable	UJ234
	Clamp Kit (Fr. Shaft; Rr.)	UJ530-10		Clamp Kit (Fr. Shaft; Rr.)	UJ530-10
	U-Joint (Rr. Shaft; Frt.)⊙	UJ351		U-Joint (Rr. Shaft; Frt.)⊙	UJ330
	(For Aluminum Drive Shaft)	UJ351C		Brute Force Greaseable	UJ295
	Brute Force Non Greaseable	UJ351BF		(For Aluminum Drive Shaft)	UJ330C
	U-Joint (Rr. Shaft; Rr.)⊙	UJ351		Clamp Kit (Rr. Shaft; Frt.)	UJ492-10
	(For Aluminum Drive Shaft)	UJ351C		U-Joint (Rr. Shaft; Rr.)⊙	UJ330
	Brute Force Non Greaseable	UJ351BF		Brute Force Greaseable	UJ295
2004	Silverado & Sierra w/ Ext. Cab, 5 Spd. Auto. Trans. & 1.188" Dia. Rr. Shaft Brg. Caps: [Type 13]			(For Aluminum Drive Shaft)	UJ330C
	U-Joint (Fr. Shaft; Frt.)⊙	UJ534G		Clamp Kit (Rr. Shaft; Rr.)	UJ492-10
	Brute Force Greaseable	UJ235			(Continued)
	Brute Force Non Greaseable	UJ234			
	Clamp Kit (Fr. Shaft; Frt.)	UJ530-10			
	U-Joint (Fr. Shaft; Rr.)⊙	UJ534G			
	Brute Force Greaseable	UJ235			
	Brute Force Non Greaseable	UJ234			
	Clamp Kit (Fr. Shaft; Rr.)	UJ530-10			
	U-Joint (Rr. Shaft; Frt.)⊙	UJ330			
	Brute Force Greaseable	UJ295			
	(For Aluminum Drive Shaft)	UJ330C			
	Clamp Kit (Rr. Shaft; Frt.)	UJ492-10			
	U-Joint (Rr. Shaft; Rr.)⊙	UJ330			
	Brute Force Greaseable	UJ295			
	(For Aluminum Drive Shaft)	UJ330C			
	Clamp Kit (Rr. Shaft; Rr.)	UJ492-10			

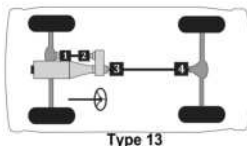

206 ▲ For Use w/ 1.063" Bearing Cap Application. ⊙ For Use w/ 1.188" Bearing Cap Application. ◇ For Use w/ Inner Lock Ring Application on Half Shaft. □ For Use w/ Outer Lock Ring Application on Half Shaft.

Passenger cars, light & medium trucks

(Cont.) -- Chevrolet/GMC Truck 1 ton

MFG./YEAR	MODEL & LOCATION	PART NO.	MFG./YEAR	MODEL & LOCATION	PART NO.
Drive Shaft (4 W/D) (Cont.)			Drive Shaft (4 W/D) (Cont.)		
U-Joint (Cont.)			U-Joint (Cont.)		
2004-2001 Silverado & Sierra w/ Ext. Cab & 5 Spd. Man. Trans.: [Type 14]			2004-2001 Silverado & Sierra w/ Crew Cab & Auto. Trans.: [Type 14]		
	U-Joint (Frt. Shaft; Frt.) ①	UJ534G		U-Joint (Frt. Shaft; Frt.) ①	UJ534G
	<i>Brute Force Greaseable</i>	UJ235		<i>Brute Force Greaseable</i>	UJ235
	<i>Brute Force Non Greaseable</i>	UJ234		<i>Brute Force Non Greaseable</i>	UJ234
	Clamp Kit (Frt. Shaft; Frt.)	UJ530-10		Clamp Kit (Frt. Shaft; Frt.)	UJ530-10
	U-Joint (Frt. Shaft; Rr.) ②	UJ534G		U-Joint (Frt. Shaft; Rr.) ②	UJ534G
	<i>Brute Force Greaseable</i>	UJ235		<i>Brute Force Greaseable</i>	UJ235
	<i>Brute Force Non Greaseable</i>	UJ234		<i>Brute Force Non Greaseable</i>	UJ234
	Clamp Kit (Frt. Shaft; Rr.)	UJ530-10		Clamp Kit (Frt. Shaft; Rr.)	UJ530-10
	U-Joint (Rr. Shaft; Frt.) ③	UJ330		U-Joint (Rr. Shaft; Frt.) ③	UJ330
	<i>Brute Force Greaseable</i>	UJ295		<i>Brute Force Greaseable</i>	UJ295
	(For Aluminum Drive Shaft)	UJ330C		(For Aluminum Drive Shaft)	UJ330C
	Clamp Kit (Rr. Shaft; Frt.)	UJ492-10		Clamp Kit (Rr. Shaft; Frt.)	UJ492-10
	U-Joint (Rr. Shaft; Ctr.) ④	UJ330		U-Joint (Rr. Shaft; Ctr.) ④	UJ330
	<i>Brute Force Greaseable</i>	UJ295		<i>Brute Force Greaseable</i>	UJ295
	(For Aluminum Drive Shaft)	UJ330C		(For Aluminum Drive Shaft)	UJ330C
	Clamp Kit (Rr. Shaft; Ctr.)	UJ492-10		Clamp Kit (Rr. Shaft; Ctr.)	UJ492-10
	U-Joint (Rr. Shaft; Rr.) ⑤	UJ330		U-Joint (Rr. Shaft; Rr.) ⑤	UJ330
	<i>Brute Force Greaseable</i>	UJ295		<i>Brute Force Greaseable</i>	UJ295
	(For Aluminum Drive Shaft)	UJ330C		(For Aluminum Drive Shaft)	UJ330C
	Clamp Kit (Rr. Shaft; Rr.)	UJ492-10		Clamp Kit (Rr. Shaft; Rr.)	UJ492-10
	2004-2001 Silverado & Sierra w/ Ext. Cab & 6 Spd. Man. Trans.: [Type 14]			2004-2001 Silverado & Sierra w/ Crew Cab & 5 Spd. Man. Trans.: [Type 14]	
	U-Joint (Frt. Shaft; Frt.) ①	UJ534G		U-Joint (Frt. Shaft; Frt.) ①	UJ534G
	<i>Brute Force Greaseable</i>	UJ235		<i>Brute Force Greaseable</i>	UJ235
	<i>Brute Force Non Greaseable</i>	UJ234		<i>Brute Force Non Greaseable</i>	UJ234
	Clamp Kit (Frt. Shaft; Frt.)	UJ530-10		Clamp Kit (Frt. Shaft; Frt.)	UJ530-10
	U-Joint (Frt. Shaft; Rr.) ②	UJ534G		U-Joint (Frt. Shaft; Rr.) ②	UJ534G
	<i>Brute Force Greaseable</i>	UJ235		<i>Brute Force Greaseable</i>	UJ235
	<i>Brute Force Non Greaseable</i>	UJ234		<i>Brute Force Non Greaseable</i>	UJ234
	Clamp Kit (Frt. Shaft; Rr.)	UJ530-10		Clamp Kit (Frt. Shaft; Rr.)	UJ530-10
	U-Joint (Rr. Shaft; Frt.) ③	UJ351		U-Joint (Rr. Shaft; Frt.) ③	UJ330
	(For Aluminum Drive Shaft)	UJ351C		<i>Brute Force Greaseable</i>	UJ295
	<i>Brute Force Non Greaseable</i>	UJ351BF		(For Aluminum Drive Shaft)	UJ330C
	U-Joint (Rr. Shaft; Ctr.) ④	UJ351		Clamp Kit (Rr. Shaft; Frt.)	UJ492-10
	(For Aluminum Drive Shaft)	UJ351C		U-Joint (Rr. Shaft; Ctr.) ④	UJ330
	<i>Brute Force Non Greaseable</i>	UJ351BF		<i>Brute Force Greaseable</i>	UJ295
	U-Joint (Rr. Shaft; Rr.) ⑤	UJ351		(For Aluminum Drive Shaft)	UJ330C
	(For Aluminum Drive Shaft)	UJ351C		Clamp Kit (Rr. Shaft; Ctr.)	UJ492-10
	<i>Brute Force Non Greaseable</i>	UJ351BF		U-Joint (Rr. Shaft; Rr.) ⑤	UJ330
				<i>Brute Force Greaseable</i>	UJ295
				(For Aluminum Drive Shaft)	UJ330C
				Clamp Kit (Rr. Shaft; Rr.)	UJ492-10

(Continued)

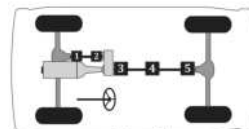

Type 14

Passenger cars, light & medium trucks

Chevrolet/GMC Truck 1 ton -- (Cont.)

MFG./YEAR	MODEL & LOCATION	PART NO.	MFG./YEAR	MODEL & LOCATION	PART NO.
Drive Shaft (4 W/D) (Cont.)			Drive Shaft (4 W/D) (Cont.)		
U-Joint (Cont.)			U-Joint (Cont.)		
2004-2001 Silverado & Sierra w/ Crew Cab & 6 Spd. Man. Trans.: [Type 14]			2004-2001 Silverado & Sierra Cab & Chassis w/ 137" WB & 6 Spd. Man. Trans.: [Type 13]		
	U-Joint (Fr. Shaft; Frt.) ⊙	UJ534G		U-Joint (Fr. Shaft; Frt.) ⊙	UJ534G
	<i>Brute Force Greaseable</i>	UJ235		<i>Brute Force Greaseable</i>	UJ235
	<i>Brute Force Non Greaseable</i>	UJ234		<i>Brute Force Non Greaseable</i>	UJ234
	Clamp Kit (Fr. Shaft; Frt.)	UJ530-10		Clamp Kit (Fr. Shaft; Frt.)	UJ530-10
	U-Joint (Fr. Shaft; Rr.) ⊙	UJ534G		U-Joint (Fr. Shaft; Rr.) ⊙	UJ534G
	<i>Brute Force Greaseable</i>	UJ235		<i>Brute Force Greaseable</i>	UJ235
	<i>Brute Force Non Greaseable</i>	UJ234		<i>Brute Force Non Greaseable</i>	UJ234
	Clamp Kit (Fr. Shaft; Rr.)	UJ530-10		Clamp Kit (Fr. Shaft; Rr.)	UJ530-10
	U-Joint (Rr. Shaft; Frt.) ⊙	UJ351		U-Joint (Rr. Shaft; Frt.) ⊙	UJ351
	(For Aluminum Drive Shaft)	UJ351C		(For Aluminum Drive Shaft)	UJ351C
	<i>Brute Force Non Greaseable</i>	UJ351BF		<i>Brute Force Non Greaseable</i>	UJ351BF
	U-Joint (Rr. Shaft; Ctr.) ⊙	UJ351		U-Joint (Rr. Shaft; Ctr.) ⊙	UJ351
	(For Aluminum Drive Shaft)	UJ351C		(For Aluminum Drive Shaft)	UJ351C
	<i>Brute Force Non Greaseable</i>	UJ351BF		<i>Brute Force Non Greaseable</i>	UJ351BF
	U-Joint (Rr. Shaft; Rr.) ⊙	UJ351		U-Joint (Rr. Shaft; Rr.) ⊙	UJ351
	(For Aluminum Drive Shaft)	UJ351C		(For Aluminum Drive Shaft)	UJ351C
	<i>Brute Force Non Greaseable</i>	UJ351BF		<i>Brute Force Non Greaseable</i>	UJ351BF
	2004-2001 Silverado & Sierra Cab & Chassis w/ 137" WB Exc. 6 Spd. Man. Trans.: [Type 13]			2004-2001 Silverado & Sierra Cab & Chassis w/ 161.5" WB Exc. 6 Spd. Man. Trans.: [Type 14]	
	U-Joint (Fr. Shaft; Frt.) ⊙	UJ534G		U-Joint (Fr. Shaft; Frt.) ⊙	UJ534G
	<i>Brute Force Greaseable</i>	UJ235		<i>Brute Force Greaseable</i>	UJ235
	<i>Brute Force Non Greaseable</i>	UJ234		<i>Brute Force Non Greaseable</i>	UJ234
	Clamp Kit (Fr. Shaft; Frt.)	UJ530-10		Clamp Kit (Fr. Shaft; Frt.)	UJ530-10
	U-Joint (Fr. Shaft; Rr.) ⊙	UJ534G		U-Joint (Fr. Shaft; Rr.) ⊙	UJ534G
	<i>Brute Force Greaseable</i>	UJ235		<i>Brute Force Greaseable</i>	UJ235
	<i>Brute Force Non Greaseable</i>	UJ234		<i>Brute Force Non Greaseable</i>	UJ234
	Clamp Kit (Fr. Shaft; Rr.)	UJ530-10		Clamp Kit (Fr. Shaft; Rr.)	UJ530-10
	U-Joint (Rr. Shaft; Frt.) ⊙	UJ330		U-Joint (Rr. Shaft; Frt.) ⊙	UJ330
	<i>Brute Force Greaseable</i>	UJ295		<i>Brute Force Greaseable</i>	UJ295
	(For Aluminum Drive Shaft)	UJ330C		(For Aluminum Drive Shaft)	UJ330C
	Clamp Kit (Rr. Shaft; Frt.)	UJ492-10		Clamp Kit (Rr. Shaft; Frt.)	UJ492-10
	U-Joint (Rr. Shaft; Rr.) ⊙	UJ330		U-Joint (Rr. Shaft; Rr.) ⊙	UJ330
	<i>Brute Force Greaseable</i>	UJ295		<i>Brute Force Greaseable</i>	UJ295
	(For Aluminum Drive Shaft)	UJ330C		(For Aluminum Drive Shaft)	UJ330C
	Clamp Kit (Rr. Shaft; Rr.)	UJ492-10		Clamp Kit (Rr. Shaft; Rr.)	UJ492-10

(Continued)

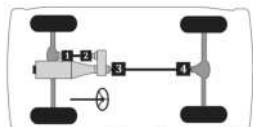

Type 13

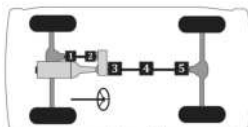

Type 14

Passenger cars, light & medium trucks

(Cont.) -- Chevrolet/GMC Truck 1 ton

MFG./YEAR	MODEL & LOCATION	PART NO.	MFG./YEAR	MODEL & LOCATION	PART NO.
Drive Shaft (4 W/D) (Cont.)			Drive Shaft (4 W/D) (Cont.)		
U-Joint (Cont.)			U-Joint (Cont.)		
2004-2001 Silverado & Sierra Cab & Chassis w/ 161.5" WB & 6 Spd. Man. Trans.: [Type 14]			2003-2001 Silverado & Sierra w/ Reg. Cab & 5 Spd. Auto. Trans.: [Type 13]		
U-Joint (Frnt. Shaft; Frnt.) ^①		UJ534G	U-Joint (Frnt. Shaft; Frnt.) ^①		UJ534G
Brute Force Greaseable		UJ235	Brute Force Greaseable		UJ235
Brute Force Non Greaseable		UJ234	Brute Force Non Greaseable		UJ234
Clamp Kit (Frnt. Shaft; Frnt.)		UJ530-10	Clamp Kit (Frnt. Shaft; Frnt.)		UJ530-10
U-Joint (Frnt. Shaft; Rr.) ^②		UJ534G	U-Joint (Frnt. Shaft; Rr.) ^②		UJ534G
Brute Force Greaseable		UJ235	Brute Force Greaseable		UJ235
Brute Force Non Greaseable		UJ234	Brute Force Non Greaseable		UJ234
Clamp Kit (Frnt. Shaft; Rr.)		UJ530-10	Clamp Kit (Frnt. Shaft; Rr.)		UJ530-10
U-Joint (Rr. Shaft; Frnt.) ^③		UJ351	U-Joint (Rr. Shaft; Frnt.) ^③		UJ330
(For Aluminum Drive Shaft)		UJ351C	Brute Force Greaseable		UJ295
Brute Force Non Greaseable		UJ351BF	(For Aluminum Drive Shaft)		UJ330C
U-Joint (Rr. Shaft; Ctr.) ^④		UJ351	Clamp Kit (Rr. Shaft; Frnt.)		UJ492-10
(For Aluminum Drive Shaft)		UJ351C	U-Joint (Rr. Shaft; Rr.) ^⑤		UJ330
Brute Force Non Greaseable		UJ351BF	Brute Force Greaseable		UJ295
U-Joint (Rr. Shaft; Rr.) ^⑥		UJ351	(For Aluminum Drive Shaft)		UJ330C
(For Aluminum Drive Shaft)		UJ351C	Clamp Kit (Rr. Shaft; Rr.)		UJ492-10
Brute Force Non Greaseable		UJ351BF	2003-2001 Silverado & Sierra w/ Reg. Cab & 5 Spd. Man. Trans.: [Type 13]		
2003-2001 Silverado & Sierra w/ Reg. Cab & 4 Spd. Auto. Trans.: [Type 13]			U-Joint (Frnt. Shaft; Frnt.) ^①		UJ534G
U-Joint (Frnt. Shaft; Frnt.) ^①		UJ534G	Brute Force Greaseable		UJ235
Brute Force Greaseable		UJ235	Brute Force Non Greaseable		UJ234
Brute Force Non Greaseable		UJ234	Clamp Kit (Frnt. Shaft; Frnt.)		UJ530-10
Clamp Kit (Frnt. Shaft; Frnt.)		UJ530-10	U-Joint (Frnt. Shaft; Rr.) ^②		UJ534G
U-Joint (Frnt. Shaft; Rr.) ^②		UJ534G	Brute Force Greaseable		UJ235
Brute Force Greaseable		UJ235	Brute Force Non Greaseable		UJ234
Brute Force Non Greaseable		UJ234	Clamp Kit (Frnt. Shaft; Rr.)		UJ530-10
Clamp Kit (Frnt. Shaft; Rr.)		UJ530-10	U-Joint (Rr. Shaft; Frnt.) ^③		UJ330A
U-Joint (Rr. Shaft; Frnt.) ^③		UJ330A	Brute Force Greaseable		UJ295A
Brute Force Greaseable		UJ295A	Clamp Kit (Rr. Shaft; Frnt.)		UJ492-10
Clamp Kit (Rr. Shaft; Frnt.)		UJ492-10	U-Joint (Rr. Shaft; Rr.) ^④		UJ330A
U-Joint (Rr. Shaft; Rr.) ^④		UJ330A	Brute Force Greaseable		UJ295A
Brute Force Greaseable		UJ295A	Clamp Kit (Rr. Shaft; Rr.)		UJ492-10
Clamp Kit (Rr. Shaft; Rr.)		UJ492-10	2003-2001 Silverado & Sierra w/ Reg. Cab & 6 Spd. Man. Trans.: [Type 13]		
2003-2001 Silverado & Sierra w/ Reg. Cab & 4 Spd. Auto. Trans.: [Type 13]			U-Joint (Frnt. Shaft; Frnt.) ^①		UJ534G
U-Joint (Frnt. Shaft; Frnt.) ^①		UJ534G	Brute Force Greaseable		UJ235
Brute Force Greaseable		UJ235	Brute Force Non Greaseable		UJ234
Brute Force Non Greaseable		UJ234	Clamp Kit (Frnt. Shaft; Frnt.)		UJ530-10
Clamp Kit (Frnt. Shaft; Frnt.)		UJ530-10	U-Joint (Frnt. Shaft; Rr.) ^②		UJ534G
U-Joint (Frnt. Shaft; Rr.) ^②		UJ534G	Brute Force Greaseable		UJ235
Brute Force Greaseable		UJ235	Brute Force Non Greaseable		UJ234
Brute Force Non Greaseable		UJ234	Clamp Kit (Frnt. Shaft; Rr.)		UJ530-10
Clamp Kit (Frnt. Shaft; Rr.)		UJ530-10	U-Joint (Rr. Shaft; Frnt.) ^③		UJ351
U-Joint (Rr. Shaft; Frnt.) ^③		UJ351	(For Aluminum Drive Shaft)		UJ351C
(For Aluminum Drive Shaft)		UJ351C	Brute Force Non Greaseable		UJ351BF
Brute Force Non Greaseable		UJ351BF	U-Joint (Rr. Shaft; Rr.) ^④		UJ351
U-Joint (Rr. Shaft; Rr.) ^④		UJ351	(For Aluminum Drive Shaft)		UJ351C
(For Aluminum Drive Shaft)		UJ351C	Brute Force Non Greaseable		UJ351BF
Brute Force Non Greaseable		UJ351BF			

(Continued)

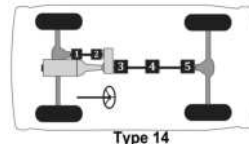
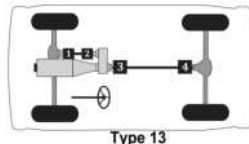

Passenger cars, light & medium trucks

Chevrolet/GMC Truck 1 ton -- (Cont.)

MFG./YEAR	MODEL & LOCATION	PART NO.	MFG./YEAR	MODEL & LOCATION	PART NO.
-----------	------------------	----------	-----------	------------------	----------

Drive Shaft (4 W/D) (Cont.)

U-Joint (Cont.)

2003-2001 Silverado & Sierra w/ Ext. Cab & 5

Spd. Auto. Trans.: [Type 13]

U-Joint (Fr. Shaft; Frt.)⊙	UJ534G
Brute Force Greaseable	UJ235
Brute Force Non Greaseable	UJ234
Clamp Kit (Fr. Shaft; Frt.)	UJ530-10
U-Joint (Fr. Shaft; Rr.)⊙	UJ534G
Brute Force Greaseable	UJ235
Brute Force Non Greaseable	UJ234
Clamp Kit (Fr. Shaft; Rr.)	UJ530-10
U-Joint (Rr. Shaft; Frt.)⊙	UJ330
Brute Force Greaseable	UJ295
(For Aluminum Drive Shaft)	UJ330C
Clamp Kit (Rr. Shaft; Frt.)	UJ492-10
U-Joint (Rr. Shaft; Rr.)⊙	UJ330
Brute Force Greaseable	UJ295
(For Aluminum Drive Shaft)	UJ330C
Clamp Kit (Rr. Shaft; Rr.)	UJ492-10
2000-1997 K3500 w/ Reg. Cab: [Type 13]	
U-Joint (Fr. Shaft; Frt.)⊙	UJ534G
Brute Force Greaseable	UJ235
Brute Force Non Greaseable	UJ234
Clamp Kit (Fr. Shaft; Frt.)	UJ530-10
U-Joint (Fr. Shaft; Rr.)⊙	UJ534G
Brute Force Greaseable	UJ235
Brute Force Non Greaseable	UJ234
Clamp Kit (Fr. Shaft; Rr.)	UJ530-10
U-Joint (Rr. Shaft; Frt.)⊙	UJ331
Brute Force Greaseable	UJ232
(For Aluminum Drive Shaft)	UJ331C
Clamp Kit (Rr. Shaft; Frt.)	UJ492-10
U-Joint (Rr. Shaft; Rr.)⊙	UJ331
Brute Force Greaseable	UJ232
Brute Force Non Greaseable	UJ231
(For Aluminum Drive Shaft)	UJ331C
Clamp Kit (Rr. Shaft; Rr.)	UJ492-10

Drive Shaft (4 W/D) (Cont.)

U-Joint (Cont.)

2000-1997 K3500 w/ Ext. Cab: [Type 14]

U-Joint (Fr. Shaft; Frt.)⊙	UJ534G
Brute Force Greaseable	UJ235
Brute Force Non Greaseable	UJ234
Clamp Kit (Fr. Shaft; Frt.)	UJ530-10
U-Joint (Fr. Shaft; Rr.)⊙	UJ534G
Brute Force Greaseable	UJ235
Brute Force Non Greaseable	UJ234
Clamp Kit (Fr. Shaft; Rr.)	UJ530-10
U-Joint (Rr. Shaft; Frt.)⊙	UJ331
Brute Force Greaseable	UJ232
Brute Force Non Greaseable	UJ231
(For Aluminum Drive Shaft)	UJ331C
Clamp Kit (Rr. Shaft; Frt.)	UJ492-10
U-Joint (Rr. Shaft; Ctr.)⊙	UJ331
Brute Force Greaseable	UJ232
Brute Force Non Greaseable	UJ231
(For Aluminum Drive Shaft)	UJ331C
Clamp Kit (Rr. Shaft; Ctr.)	UJ492-10
U-Joint (Rr. Shaft; Rr.)⊙	UJ331
Brute Force Greaseable	UJ232
Brute Force Non Greaseable	UJ231
(For Aluminum Drive Shaft)	UJ331C
Clamp Kit (Rr. Shaft; Rr.)	UJ492-10
2000-1997 K3500 w/ Crew Cab: [Type 14]	
U-Joint (Fr. Shaft; Frt.)⊙	UJ534G
Brute Force Greaseable	UJ235
Brute Force Non Greaseable	UJ234
Clamp Kit (Fr. Shaft; Frt.)	UJ530-10
U-Joint (Fr. Shaft; Rr.)⊙	UJ534G
Brute Force Greaseable	UJ235
Brute Force Non Greaseable	UJ234
Clamp Kit (Fr. Shaft; Rr.)	UJ530-10
U-Joint (Rr. Shaft; Frt.)⊙	UJ331
Brute Force Greaseable	UJ232
Brute Force Non Greaseable	UJ231
(For Aluminum Drive Shaft)	UJ331C
Clamp Kit (Rr. Shaft; Frt.)	UJ492-10
U-Joint (Rr. Shaft; Ctr.)⊙	UJ331
Brute Force Greaseable	UJ232
Brute Force Non Greaseable	UJ231
(For Aluminum Drive Shaft)	UJ331C
Clamp Kit (Rr. Shaft; Ctr.)	UJ492-10
U-Joint (Rr. Shaft; Rr.)⊙	UJ331
Brute Force Greaseable	UJ232
Brute Force Non Greaseable	UJ231
(For Aluminum Drive Shaft)	UJ331C
Clamp Kit (Rr. Shaft; Rr.)	UJ492-10

(Continued)

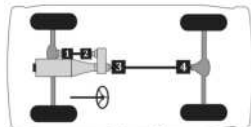

Type 13

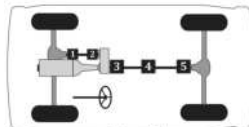

Type 14

SKF

Passenger cars, light & medium trucks

(Cont.) -- Chevrolet/GMC Truck 1 ton

MFG./YEAR	MODEL & LOCATION	PART NO.	MFG./YEAR	MODEL & LOCATION	PART NO.
Drive Shaft (4 W/D) (Cont.)			Drive Shaft (4 W/D) (Cont.)		
U-Joint (Cont.)			U-Joint (Cont.)		
2000-1997 K3500 Cab & Chassis w/ 135.5" & 141.5" Wheelbase: [Type 13]			1996-1992 K3500 w/ 2 Joint Shaft: [Type 13]		
	U-Joint (Fr. Shaft; Fr.) ①	UJ534G		U-Joint (Fr. Shaft; Fr.) ①	UJ534G
	<i>Brute Force Greaseable</i>	UJ235		<i>Brute Force Greaseable</i>	UJ235
	<i>Brute Force Non Greaseable</i>	UJ234		<i>Brute Force Non Greaseable</i>	UJ234
	Clamp Kit (Fr. Shaft; Fr.)	UJ530-10		Clamp Kit (Fr. Shaft; Fr.)	UJ530-10
	U-Joint (Fr. Shaft; Rr.) ②	UJ534G		U-Joint (Fr. Shaft; Rr.) ②	UJ534G
	<i>Brute Force Greaseable</i>	UJ235		<i>Brute Force Greaseable</i>	UJ235
	<i>Brute Force Non Greaseable</i>	UJ234		<i>Brute Force Non Greaseable</i>	UJ234
	Clamp Kit (Fr. Shaft; Rr.)	UJ530-10		Clamp Kit (Fr. Shaft; Rr.)	UJ530-10
	U-Joint (Rr. Shaft; Fr.) ③	UJ330		U-Joint (Rr. Shaft; Fr.) ③	UJ331
	<i>Brute Force Greaseable</i>	UJ295		<i>Brute Force Greaseable</i>	UJ232
	<i>Brute Force Non Greaseable</i>	UJ330C		<i>Brute Force Non Greaseable</i>	UJ231
	(For Aluminum Drive Shaft)	UJ330C		(For Aluminum Drive Shaft)	UJ331C
	Clamp Kit (Rr. Shaft; Fr.)	UJ492-10		Clamp Kit (Rr. Shaft; Fr.)	UJ331
	U-Joint (Rr. Shaft; Rr.) ④	UJ330		U-Joint (Rr. Shaft; Rr.) ④	UJ232
	<i>Brute Force Greaseable</i>	UJ295		<i>Brute Force Greaseable</i>	UJ231
	<i>Brute Force Non Greaseable</i>	UJ330C		<i>Brute Force Non Greaseable</i>	UJ231
	(For Aluminum Drive Shaft)	UJ330C		(For Aluminum Drive Shaft)	UJ331C
	Clamp Kit (Rr. Shaft; Rr.)	UJ492-10		1996-1992 K3500 w/ 3 Joint Shaft: [Type 14]	
2000-1997 K3500 Cab & Chassis w/ 159.5", 168.5" & 183.5" Wheelbase: [Type 14]				U-Joint (Fr. Shaft; Fr.) ①	UJ534G
	U-Joint (Fr. Shaft; Fr.) ①	UJ534G		<i>Brute Force Greaseable</i>	UJ235
	<i>Brute Force Greaseable</i>	UJ235		<i>Brute Force Non Greaseable</i>	UJ234
	<i>Brute Force Non Greaseable</i>	UJ234		Clamp Kit (Fr. Shaft; Fr.)	UJ530-10
	Clamp Kit (Fr. Shaft; Fr.)	UJ530-10		U-Joint (Fr. Shaft; Rr.) ②	UJ534G
	U-Joint (Fr. Shaft; Rr.) ②	UJ534G		<i>Brute Force Greaseable</i>	UJ235
	<i>Brute Force Greaseable</i>	UJ235		<i>Brute Force Non Greaseable</i>	UJ234
	<i>Brute Force Non Greaseable</i>	UJ234		Clamp Kit (Fr. Shaft; Rr.)	UJ530-10
	Clamp Kit (Fr. Shaft; Rr.)	UJ530-10		U-Joint (Rr. Shaft; Fr.) ③	UJ331
	U-Joint (Rr. Shaft; Fr.) ③	UJ330		<i>Brute Force Greaseable</i>	UJ232
	<i>Brute Force Greaseable</i>	UJ295		<i>Brute Force Non Greaseable</i>	UJ231
	<i>Brute Force Non Greaseable</i>	UJ330C		(For Aluminum Drive Shaft)	UJ331C
	(For Aluminum Drive Shaft)	UJ330C		U-Joint (Rr. Shaft; Ctr.) ④	UJ331
	Clamp Kit (Rr. Shaft; Fr.)	UJ492-10		<i>Brute Force Greaseable</i>	UJ232
	U-Joint (Rr. Shaft; Ctr.) ④	UJ330		<i>Brute Force Non Greaseable</i>	UJ231
	<i>Brute Force Greaseable</i>	UJ295		(For Aluminum Drive Shaft)	UJ331C
	<i>Brute Force Non Greaseable</i>	UJ330C		U-Joint (Rr. Shaft; Rr.) ⑤	UJ331
	(For Aluminum Drive Shaft)	UJ330C		<i>Brute Force Greaseable</i>	UJ232
	Clamp Kit (Rr. Shaft; Ctr.)	UJ492-10		<i>Brute Force Non Greaseable</i>	UJ231
	U-Joint (Rr. Shaft; Rr.) ⑤	UJ330		(For Aluminum Drive Shaft)	UJ331C
	<i>Brute Force Greaseable</i>	UJ295			
	<i>Brute Force Non Greaseable</i>	UJ330C			
	(For Aluminum Drive Shaft)	UJ330C			
	Clamp Kit (Rr. Shaft; Rr.)	UJ492-10			

(Continued)

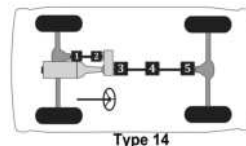
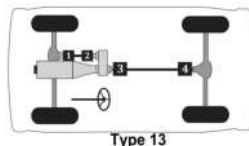

Passenger cars, light & medium trucks

Chevrolet/GMC Truck 1 ton -- (Cont.)

MFG./YEAR	MODEL & LOCATION	PART NO.	MFG./YEAR	MODEL & LOCATION	PART NO.
-----------	------------------	----------	-----------	------------------	----------

Drive Shaft (4 W/D) (Cont.)

U-Joint (Cont.)

1991-1990 K3500 & V3500 w/ 2 Doors, CV Frt.

Axles, Auto. Trans., 2 Joint Rr. Shaft
& Single Rr. Whls.: [Type 13]

U-Joint (Frt. Shaft; Frt.) ⊙	UJ534G
Brute Force Greaseable	UJ235
Brute Force Non Greaseable	UJ234
U-Joint (Frt. Shaft; Rr.) ⊙	UJ534G
Brute Force Greaseable	UJ235
Brute Force Non Greaseable	UJ234
U-Joint (Rr. Shaft; Frt.) ⊙	UJ331
Brute Force Greaseable	UJ232
Brute Force Non Greaseable	UJ231
(For Aluminum Drive Shaft)	UJ331C
Clamp Kit (Rr. Shaft; Frt.)	UJ492-10
U-Joint (Rr. Shaft; Rr.) ⊙	UJ331
Brute Force Greaseable	UJ232
Brute Force Non Greaseable	UJ231
(For Aluminum Drive Shaft)	UJ331C
Clamp Kit (Rr. Shaft; Rr.)	UJ492-10

1991-1990 K3500 & V3500 w/ 2 Doors, CV Frt.

Axles, Auto. Trans., 3 Joint Rr. Shaft
& Single Rr. Whls.: [Type 14]

U-Joint (Frt. Shaft; Frt.) ⊙	UJ534G
Brute Force Greaseable	UJ235
Brute Force Non Greaseable	UJ234
U-Joint (Frt. Shaft; Rr.) ⊙	UJ534G
Brute Force Greaseable	UJ235
Brute Force Non Greaseable	UJ234
U-Joint (Rr. Shaft; Frt.) ⊙	UJ331
Brute Force Greaseable	UJ232
Brute Force Non Greaseable	UJ231
(For Aluminum Drive Shaft)	UJ331C
Clamp Kit (Rr. Shaft; Frt.)	UJ492-10
U-Joint (Rr. Shaft; Ctr.) ⊙	UJ331
Brute Force Greaseable	UJ232
Brute Force Non Greaseable	UJ231
(For Aluminum Drive Shaft)	UJ331C
Clamp Kit (Rr. Shaft; Ctr.)	UJ492-10
U-Joint (Rr. Shaft; Rr.) ⊙	UJ331
Brute Force Greaseable	UJ232
Brute Force Non Greaseable	UJ231
(For Aluminum Drive Shaft)	UJ331C
Clamp Kit (Rr. Shaft; Rr.)	UJ492-10

Drive Shaft (4 W/D) (Cont.)

U-Joint (Cont.)

1991-1990 K3500 & V3500 w/ 2 Doors, CV Frt.

Axles, Auto. Trans., 2 Joint Rr. Shaft
& Dual Rr. Whls.: [Type 13]

U-Joint (Frt. Shaft; Frt.) ⊙	UJ355
Brute Force Greaseable	UJ290
(For Aluminum Drive Shaft)	UJ355C
U-Joint (Frt. Shaft; Rr.) ⊙	UJ354
Brute Force Greaseable	UJ270
Brute Force Non Greaseable	UJ254
(For Aluminum Drive Shaft)	UJ354C
U-Joint (Rr. Shaft; Frt.) ⊙	UJ331
Brute Force Greaseable	UJ232
Brute Force Non Greaseable	UJ231
(For Aluminum Drive Shaft)	UJ331C
Clamp Kit (Rr. Shaft; Frt.)	UJ492-10
U-Joint (Rr. Shaft; Rr.) ⊙	UJ331
Brute Force Greaseable	UJ232
Brute Force Non Greaseable	UJ231
(For Aluminum Drive Shaft)	UJ331C
Clamp Kit (Rr. Shaft; Rr.)	UJ492-10

1991-1990 K3500 & V3500 w/ 2 Doors, CV Frt.

Axles, Auto. Trans., 3 Joint Rr. Shaft
& Dual Rr. Whls.: [Type 14]

U-Joint (Frt. Shaft; Frt.) ⊙	UJ355
Brute Force Greaseable	UJ290
(For Aluminum Drive Shaft)	UJ355C
Clamp Kit (Frt. Shaft; Frt.)	UJ530-10
U-Joint (Frt. Shaft; Rr.) ⊙	UJ354
Brute Force Greaseable	UJ270
Brute Force Non Greaseable	UJ254
(For Aluminum Drive Shaft)	UJ354C
U-Joint (Rr. Shaft; Frt.) ⊙	UJ331
Brute Force Greaseable	UJ232
Brute Force Non Greaseable	UJ231
(For Aluminum Drive Shaft)	UJ331C
Clamp Kit (Rr. Shaft; Frt.)	UJ492-10
U-Joint (Rr. Shaft; Ctr.) ⊙	UJ331
Brute Force Greaseable	UJ232
Brute Force Non Greaseable	UJ231
(For Aluminum Drive Shaft)	UJ331C
Clamp Kit (Rr. Shaft; Ctr.)	UJ492-10
U-Joint (Rr. Shaft; Rr.) ⊙	UJ331
Brute Force Greaseable	UJ232
Brute Force Non Greaseable	UJ231
(For Aluminum Drive Shaft)	UJ331C
Clamp Kit (Rr. Shaft; Rr.)	UJ492-10

(Continued)

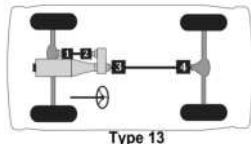

Type 13

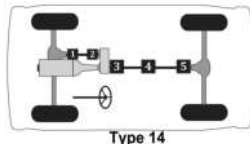

Type 14

Passenger cars, light & medium trucks

(Cont.) -- Chevrolet/GMC Truck 1 ton

MFG./YEAR	MODEL & LOCATION	PART NO.	MFG./YEAR	MODEL & LOCATION	PART NO.
Drive Shaft (4 W/D) (Cont.)			Drive Shaft (4 W/D) (Cont.)		
U-Joint (Cont.)			U-Joint (Cont.)		
1991-1990 K3500 & V3500 w/ 2 Doors, CV Frt.			1991-1990 K3500 & V3500 w/ 4 Doors &		
Axles, Man. Trans. & 2 Joint Rr. Shaft:			Monobeam Frt. Axle: [Type 27]		
[Type 13]					
U-Joint (Frt. Shaft; Frt.) ^①		UJ355	U-Joint (Frt. Shaft; Frt.) ^①		UJ369
Brute Force Greaseable		UJ290	Brute Force Greaseable		UJ280
(For Aluminum Drive Shaft)		UJ355C	Brute Force Non Greaseable		UJ269
Clamp Kit (Frt. Shaft; Frt.)		UJ530-10	(For Aluminum Drive Shaft)		UJ369C
U-Joint (Frt. Shaft; Rr.) ^②		UJ354	U-Bolt Kit (Frt. Shaft; Frt.)		UJ329-10
Brute Force Greaseable		UJ270	U-Joint (Frt. Shaft; Rr.) ^②	[2]	UJ534G
Brute Force Non Greaseable		UJ254	Brute Force Greaseable		UJ235
(For Aluminum Drive Shaft)		UJ354C	Brute Force Non Greaseable		UJ234
U-Joint (Rr. Shaft; Frt.) ^③		UJ331	U-Joint (Rr. Shaft; Frt.) ^③		UJ331
Brute Force Greaseable		UJ232	Brute Force Greaseable		UJ232
Brute Force Non Greaseable		UJ231	Brute Force Non Greaseable		UJ231
(For Aluminum Drive Shaft)		UJ331C	(For Aluminum Drive Shaft)		UJ331C
Clamp Kit (Rr. Shaft; Frt.)		UJ492-10	Clamp Kit (Rr. Shaft; Frt.)		UJ492-10
U-Joint (Rr. Shaft; Rr.) ^④		UJ331	U-Joint (Rr. Shaft; Rr.) ^④		UJ331
Brute Force Greaseable		UJ232	Brute Force Greaseable		UJ232
Brute Force Non Greaseable		UJ231	Brute Force Non Greaseable		UJ231
(For Aluminum Drive Shaft)		UJ331C	(For Aluminum Drive Shaft)		UJ331C
Clamp Kit (Rr. Shaft; Rr.)		UJ492-10	Clamp Kit (Rr. Shaft; Ctr.)		UJ492-10
1991-1990 K3500 & V3500 w/ 2 Doors, CV Frt.			U-Joint (Rr. Shaft; Rr.) ^⑤		UJ331
Axles, Man. Trans. & 3 Joint Rr. Shaft:			Brute Force Greaseable		UJ232
[Type 14]			Brute Force Non Greaseable		UJ231
U-Joint (Frt. Shaft; Frt.) ^①		UJ355	(For Aluminum Drive Shaft)		UJ331C
Brute Force Greaseable		UJ290	Clamp Kit (Rr. Shaft; Rr.)		UJ492-10
(For Aluminum Drive Shaft)		UJ355C	U-Joint (Wheel Joint) ^⑥	[2]	UJ374
Clamp Kit (Frt. Shaft; Frt.)		UJ530-10	Brute Force Non Greaseable		UJ374BF
U-Joint (Frt. Shaft; Rr.) ^②		UJ354	Ball Seat Repair Kit		UJ606
Brute Force Greaseable		UJ270	Flange Yoke		UJ626
Brute Force Non Greaseable		UJ254	H Yoke		UJ646
(For Aluminum Drive Shaft)		UJ354C	1989-1988 K3500, V30 & V3500 w/ CV Frt. Axles,		
U-Joint (Rr. Shaft; Frt.) ^③		UJ331	2 Joint Rr. Shaft & Inner Lock Rings:		
Brute Force Greaseable		UJ232	[Type 13]		
Brute Force Non Greaseable		UJ231	U-Joint (Frt. Shaft; Frt.) ^①		UJ534G
(For Aluminum Drive Shaft)		UJ331C	Brute Force Greaseable		UJ235
Clamp Kit (Rr. Shaft; Frt.)		UJ492-10	Brute Force Non Greaseable		UJ234
U-Joint (Rr. Shaft; Ctr.) ^④		UJ331	Clamp Kit (Frt. Shaft; Frt.)		UJ530-10
Brute Force Greaseable		UJ232	U-Joint (Frt. Shaft; Rr.) ^②		UJ534G
Brute Force Non Greaseable		UJ231	Brute Force Greaseable		UJ235
(For Aluminum Drive Shaft)		UJ331C	Brute Force Non Greaseable		UJ234
Clamp Kit (Rr. Shaft; Ctr.)		UJ492-10	Clamp Kit (Frt. Shaft; Rr.)		UJ530-10
U-Joint (Rr. Shaft; Rr.) ^⑤		UJ331	U-Joint (Rr. Shaft; Frt.) ^③		UJ331
Brute Force Greaseable		UJ232	Brute Force Greaseable		UJ232
Brute Force Non Greaseable		UJ231	Brute Force Non Greaseable		UJ231
(For Aluminum Drive Shaft)		UJ331C	(For Aluminum Drive Shaft)		UJ331C
Clamp Kit (Rr. Shaft; Rr.)		UJ492-10	Clamp Kit (Rr. Shaft; Frt.)		UJ492-10
U-Joint (Rr. Shaft; Rr.) ^⑥		UJ331	U-Joint (Rr. Shaft; Rr.) ^④		UJ331
Brute Force Greaseable		UJ232	Brute Force Greaseable		UJ232
Brute Force Non Greaseable		UJ231	Brute Force Non Greaseable		UJ231
(For Aluminum Drive Shaft)		UJ331C	(For Aluminum Drive Shaft)		UJ331C
Clamp Kit (Rr. Shaft; Rr.)		UJ492-10	Clamp Kit (Rr. Shaft; Rr.)		UJ492-10
			U-Joint (Rr. Shaft; Rr.) ^⑤		UJ331
			Brute Force Greaseable		UJ232
			Brute Force Non Greaseable		UJ231
			(For Aluminum Drive Shaft)		UJ331C
			Clamp Kit (Rr. Shaft; Rr.)		UJ492-10
			U-Joint (Rr. Shaft; Rr.) ^⑥		UJ331
			Brute Force Greaseable		UJ232
			Brute Force Non Greaseable		UJ231
			(For Aluminum Drive Shaft)		UJ331C
			Clamp Kit (Rr. Shaft; Rr.)		UJ492-10

(Continued)

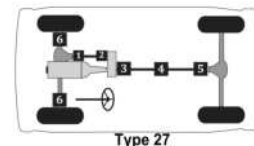
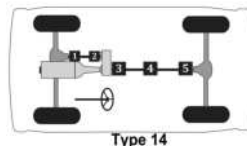
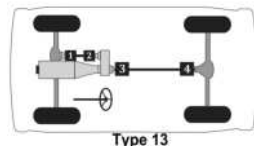

Passenger cars, light & medium trucks

Chevrolet/GMC Truck 1 ton -- (Cont.)

MFG./YEAR MODEL & LOCATION PART NO. MFG./YEAR MODEL & LOCATION PART NO.

Drive Shaft (4 W/D) (Cont.)

U-Joint (Cont.)

1989-1988 K3500, V30 & V3500 w/ CV Frt. Axles,
2 Joint Rr. Shaft & Outer Lock Rings:

[Type 13]

U-Joint (Frt. Shaft; Frt.) ⊙	UJ355
Brute Force Greaseable	UJ290
(For Aluminum Drive Shaft)	UJ355C
Clamp Kit (Frt. Shaft; Frt.)	UJ530-10
U-Joint (Frt. Shaft; Rr.) ⊙	UJ354
Brute Force Greaseable	UJ270
Brute Force Non Greaseable	UJ254
(For Aluminum Drive Shaft)	UJ354C
U-Joint (Rr. Shaft; Frt.) ⊙	UJ331
Brute Force Greaseable	UJ232
Brute Force Non Greaseable	UJ231
(For Aluminum Drive Shaft)	UJ331C
Clamp Kit (Rr. Shaft; Frt.)	UJ492-10
U-Joint (Rr. Shaft; Rr.) ⊙	UJ331
Brute Force Greaseable	UJ232
Brute Force Non Greaseable	UJ231
(For Aluminum Drive Shaft)	UJ331C
Clamp Kit (Rr. Shaft; Rr.)	UJ492-10

1989-1988 K3500, V30 & V3500 w/ CV Frt. Axles,
3 Joint Rr. Shaft & Inner Lock Rings:

[Type 14]

U-Joint (Frt. Shaft; Frt.) ⊙	UJ534G
Brute Force Greaseable	UJ235
Brute Force Non Greaseable	UJ234
Clamp Kit (Frt. Shaft; Frt.)	UJ530-10
U-Joint (Frt. Shaft; Rr.) ⊙	UJ534G
Brute Force Greaseable	UJ235
Brute Force Non Greaseable	UJ234
Clamp Kit (Frt. Shaft; Rr.)	UJ530-10
U-Joint (Rr. Shaft; Frt.) ⊙	UJ331
Brute Force Greaseable	UJ232
Brute Force Non Greaseable	UJ231
(For Aluminum Drive Shaft)	UJ331C
Clamp Kit (Rr. Shaft; Frt.)	UJ492-10
U-Joint (Rr. Shaft; Ctr.) ⊙	UJ331
Brute Force Greaseable	UJ232
Brute Force Non Greaseable	UJ231
(For Aluminum Drive Shaft)	UJ331C
Clamp Kit (Rr. Shaft; Ctr.)	UJ492-10
U-Joint (Rr. Shaft; Rr.) ⊙	UJ331
Brute Force Greaseable	UJ232
Brute Force Non Greaseable	UJ231
(For Aluminum Drive Shaft)	UJ331C
Clamp Kit (Rr. Shaft; Rr.)	UJ492-10

Drive Shaft (4 W/D) (Cont.)

U-Joint (Cont.)

1989-1988 K3500, V30 & V3500 w/ CV Frt. Axles,
3 Joint Rr. Shaft & Outer Lock Rings:

[Type 14]

U-Joint (Frt. Shaft; Frt.) ⊙	UJ355
Brute Force Greaseable	UJ290
(For Aluminum Drive Shaft)	UJ355C
Clamp Kit (Frt. Shaft; Frt.)	UJ530-10
U-Joint (Frt. Shaft; Rr.) ⊙	UJ354
Brute Force Greaseable	UJ270
Brute Force Non Greaseable	UJ254
(For Aluminum Drive Shaft)	UJ354C
U-Joint (Rr. Shaft; Frt.) ⊙	UJ331
Brute Force Greaseable	UJ232
Brute Force Non Greaseable	UJ231
(For Aluminum Drive Shaft)	UJ331C
Clamp Kit (Rr. Shaft; Frt.)	UJ492-10
U-Joint (Rr. Shaft; Ctr.) ⊙	UJ331
Brute Force Greaseable	UJ232
Brute Force Non Greaseable	UJ231
(For Aluminum Drive Shaft)	UJ331C
Clamp Kit (Rr. Shaft; Ctr.)	UJ492-10
U-Joint (Rr. Shaft; Rr.) ⊙	UJ331
Brute Force Greaseable	UJ232
Brute Force Non Greaseable	UJ231
(For Aluminum Drive Shaft)	UJ331C

1989-1988 K3500, V30 & V3500 w/ Monobeam Frt.

Axle & 2 Joint Rr. Shaft: [Type 13]

U-Joint (Frt. Shaft; Frt.) ⊙	UJ369
Brute Force Greaseable	UJ280
Brute Force Non Greaseable	UJ269
(For Aluminum Drive Shaft)	UJ369C
U-Bolt Kit (Frt. Shaft; Frt.)	UJ329-10
U-Joint (Frt. Shaft; Rr.) ⊙	[2] UJ534G
Brute Force Greaseable	UJ235
Brute Force Non Greaseable	UJ234
Clamp Kit (Frt. Shaft; Rr.)	UJ530-10
U-Joint (Rr. Shaft; Frt.) ⊙	UJ331
Brute Force Greaseable	UJ232
Brute Force Non Greaseable	UJ231
(For Aluminum Drive Shaft)	UJ331C
Clamp Kit (Rr. Shaft; Frt.)	UJ492-10
U-Joint (Rr. Shaft; Rr.) ⊙	UJ331
Brute Force Greaseable	UJ232
Brute Force Non Greaseable	UJ231
(For Aluminum Drive Shaft)	UJ331C
Clamp Kit (Rr. Shaft; Rr.)	UJ492-10
Ball Seat Repair Kit	UJ606
Flange Yoke	UJ626
H Yoke	UJ646

(Continued)

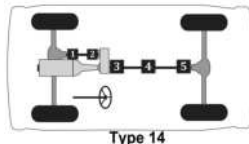
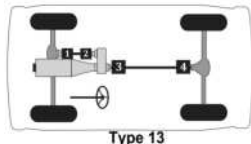

Passenger cars, light & medium trucks

(Cont.) -- Chevrolet/GMC Truck 1 ton

MFG./YEAR	MODEL & LOCATION	PART NO.	MFG./YEAR	MODEL & LOCATION	PART NO.
Drive Shaft (4 W/D) (Cont.)			Drive Shaft (4 W/D) (Cont.)		
U-Joint (Cont.)			U-Joint (Cont.)		
1989-1988 K3500, V30 & V3500 w/ Monobeam Frt.			1987-1980 K30, V30, K3500 & V3500 w/ 131.5"		
Axle & 3 Joint Rr. Shaft: [Type 27]			Wheelbase: [Type 26]		
U-Joint (Frt. Shaft; Frt.)Ⓢ		UJ369	U-Joint (Frt. Shaft; Frt.)Ⓢ		UJ369
Brute Force Greaseable		UJ280	Brute Force Greaseable		UJ280
Brute Force Non Greaseable		UJ269	Brute Force Non Greaseable		UJ269
(For Aluminum Drive Shaft)		UJ369C	(For Aluminum Drive Shaft)		UJ369C
U-Bolt Kit (Frt. Shaft; Frt.)		UJ329-10	U-Bolt Kit (Frt. Shaft; Frt.)		UJ329-10
U-Joint (Frt. Shaft; Rr.)Ⓢ	[2]	UJ534G	U-Joint (Frt. Shaft; Rr.)Ⓢ	[2]	UJ534G
Brute Force Greaseable		UJ235	Brute Force Greaseable		UJ235
Brute Force Non Greaseable		UJ234	Brute Force Non Greaseable		UJ234
Clamp Kit (Frt. Shaft; Rr.)		UJ530-10	U-Joint (Rr. Shaft; Frt.)Ⓢ		UJ331
U-Joint (Rr. Shaft; Frt.)Ⓢ		UJ331	Brute Force Greaseable		UJ232
Brute Force Greaseable		UJ232	Brute Force Non Greaseable		UJ231
Brute Force Non Greaseable		UJ231	(For Aluminum Drive Shaft)		UJ331C
(For Aluminum Drive Shaft)		UJ331C	Clamp Kit (Rr. Shaft; Frt.)		UJ492-10
Clamp Kit (Rr. Shaft; Frt.)		UJ492-10	U-Joint (Rr. Shaft; Rr.)Ⓢ		UJ331
U-Joint (Rr. Shaft; Ctr.)Ⓢ		UJ331	Brute Force Greaseable		UJ232
Brute Force Greaseable		UJ232	Brute Force Non Greaseable		UJ231
Brute Force Non Greaseable		UJ231	(For Aluminum Drive Shaft)		UJ331C
(For Aluminum Drive Shaft)		UJ331C	Clamp Kit (Rr. Shaft; Rr.)		UJ492-10
Clamp Kit (Rr. Shaft; Ctr.)		UJ492-10	U-Joint (Wheel Joint)Ⓢ	[2]	UJ374
U-Joint (Rr. Shaft; Rr.)Ⓢ		UJ331	Brute Force Non Greaseable		UJ374BF
Brute Force Greaseable		UJ232	Ball Seat Repair Kit		UJ606
Brute Force Non Greaseable		UJ231	Flange Yoke		UJ626
(For Aluminum Drive Shaft)		UJ331C	H Yoke		UJ646
Clamp Kit (Rr. Shaft; Rr.)		UJ492-10			(Continued)
U-Joint (Wheel Joint)Ⓢ	[2]	UJ374			
Brute Force Non Greaseable		UJ374BF			
Ball Seat Repair Kit		UJ606			
Flange Yoke		UJ626			
H Yoke		UJ646			

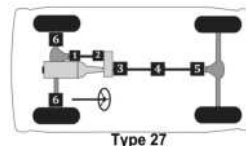
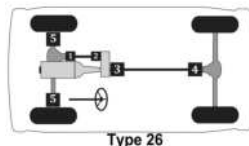

Passenger cars, light & medium trucks

Chevrolet/GMC Truck 1 ton -- (Cont.)

MFG./YEAR	MODEL & LOCATION	PART NO.	MFG./YEAR	MODEL & LOCATION	PART NO.
-----------	------------------	----------	-----------	------------------	----------

Drive Shaft (4 W/D) (Cont.)

U-Joint (Cont.)

1987-1980 K30, V30, K3500 & V3500 w/ 135.5", 159.5" & 164.5" Wheelbase: [Type 27]	
U-Joint (Fr. Shaft; Frt.) [⊙]	UJ369
Brute Force Greaseable	UJ280
Brute Force Non Greaseable	UJ269
(For Aluminum Drive Shaft)	UJ369C
U-Bolt Kit (Fr. Shaft; Frt.)	UJ329-10
U-Joint (Fr. Shaft; Rr.) [⊙]	[2] UJ534G
Brute Force Greaseable	UJ235
Brute Force Non Greaseable	UJ234
U-Joint (Rr. Shaft; Frt.) [⊙]	UJ331
Brute Force Greaseable	UJ232
Brute Force Non Greaseable	UJ231
(For Aluminum Drive Shaft)	UJ331C
Clamp Kit (Rr. Shaft; Frt.)	UJ492-10
U-Joint (Rr. Shaft; Ctr.) [⊙]	UJ331
Brute Force Greaseable	UJ232
Brute Force Non Greaseable	UJ231
(For Aluminum Drive Shaft)	UJ331C
Clamp Kit (Rr. Shaft; Ctr.)	UJ492-10
U-Joint (Rr. Shaft; Rr.) [⊙]	UJ331
Brute Force Greaseable	UJ232
Brute Force Non Greaseable	UJ231
(For Aluminum Drive Shaft)	UJ331C
Clamp Kit (Rr. Shaft; Rr.)	UJ492-10
U-Joint (Wheel Joint) [⊙]	[2] UJ374
Brute Force Non Greaseable	UJ374BF
Ball Seat Repair Kit	UJ606
Flange Yoke	UJ626
H Yoke	UJ646

Drive Shaft (4 W/D) (Cont.)

U-Joint (Cont.)

1979 K30 & K3500 w/ 3.5" Yoke: [Type 27]	
U-Joint (Fr. Shaft; Frt.) [⊙]	UJ369
Brute Force Greaseable	UJ280
Brute Force Non Greaseable	UJ269
(For Aluminum Drive Shaft)	UJ369C
U-Bolt Kit (Fr. Shaft; Frt.)	UJ329-10
U-Joint (Fr. Shaft; Rr.) [⊙]	[2] UJ379
Brute Force Greaseable	UJ280
Brute Force Non Greaseable	UJ269
U-Joint (Rr. Shaft; Frt.) [⊙]	UJ369
Brute Force Greaseable	UJ280
Brute Force Non Greaseable	UJ269
(For Aluminum Drive Shaft)	UJ369C
U-Bolt Kit (Rr. Shaft; Frt.)	UJ329-10
U-Joint (Rr. Shaft; Ctr.) [⊙]	UJ331
Brute Force Greaseable	UJ232
Brute Force Non Greaseable	UJ231
(For Aluminum Drive Shaft)	UJ331C
Clamp Kit (Rr. Shaft; Ctr.)	UJ492-10
U-Joint (Rr. Shaft; Rr.) [⊙]	UJ331
Brute Force Greaseable	UJ232
Brute Force Non Greaseable	UJ231
(For Aluminum Drive Shaft)	UJ331C
Clamp Kit (Rr. Shaft; Rr.)	UJ492-10
U-Joint (Wheel Joint) [⊙]	[2] UJ374
Brute Force Non Greaseable	UJ374BF
Centering Yoke	UJ607
H Yoke	UJ647

(Continued)

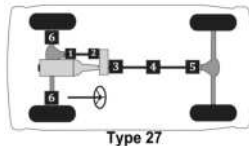

Passenger cars, light & medium trucks

(Cont.) -- Chevrolet/GMC Truck 1 ton

MFG./YEAR	MODEL & LOCATION	PART NO.	MFG./YEAR	MODEL & LOCATION	PART NO.
Drive Shaft (4 W/D) (Cont.)			Drive Shaft (4 W/D) (Cont.)		
U-Joint (Cont.)			U-Joint (Cont.)		
1979	K30 & K3500 w/ 4" Yoke: [Type 27]		1978-1977	K30 & K35: [Type 27]	
	U-Joint (Frnt. Shaft; Frt.) ^①	UJ369		U-Joint (Frnt. Shaft; Frt.) ^①	UJ369
	Brute Force Greaseable	UJ280		Brute Force Greaseable	UJ280
	Brute Force Non Greaseable	UJ269		Brute Force Non Greaseable	UJ269
	(For Aluminum Drive Shaft)	UJ369C		(For Aluminum Drive Shaft)	UJ369C
	U-Bolt Kit (Frnt. Shaft; Frt.)	UJ329-10		U-Bolt Kit (Frnt. Shaft; Frt.)	UJ329-10
	U-Joint (Frnt. Shaft; Rr.) ^②	[2] UJ379		U-Joint (Frnt. Shaft; Rr.) ^②	[2] UJ379
	Brute Force Greaseable	UJ280		Brute Force Greaseable	UJ280
	Brute Force Non Greaseable	UJ269		Brute Force Non Greaseable	UJ269
	U-Joint (Rr. Shaft; Frt.) ^③	UJ331		U-Joint (Rr. Shaft; Frt.) ^③	UJ331
	Brute Force Greaseable	UJ232		Brute Force Greaseable	UJ232
	Brute Force Non Greaseable	UJ231		Brute Force Non Greaseable	UJ231
	(For Aluminum Drive Shaft)	UJ331C		(For Aluminum Drive Shaft)	UJ331C
	Clamp Kit (Rr. Shaft; Frt.)	UJ492-10		Clamp Kit (Rr. Shaft; Frt.)	UJ492-10
	U-Joint (Rr. Shaft; Ctr.) ^④	UJ331		U-Joint (Rr. Shaft; Ctr.) ^④	UJ331
	Brute Force Greaseable	UJ232		Brute Force Greaseable	UJ232
	Brute Force Non Greaseable	UJ231		Brute Force Non Greaseable	UJ231
	(For Aluminum Drive Shaft)	UJ331C		(For Aluminum Drive Shaft)	UJ331C
	Clamp Kit (Rr. Shaft; Ctr.)	UJ492-10		Clamp Kit (Rr. Shaft; Ctr.)	UJ492-10
	U-Joint (Rr. Shaft; Rr.) ^⑤	UJ331		U-Joint (Rr. Shaft; Rr.) ^⑤	UJ331
	Brute Force Greaseable	UJ232		Brute Force Greaseable	UJ232
	Brute Force Non Greaseable	UJ231		Brute Force Non Greaseable	UJ231
	(For Aluminum Drive Shaft)	UJ331C		(For Aluminum Drive Shaft)	UJ331C
	Clamp Kit (Rr. Shaft; Rr.)	UJ492-10		Clamp Kit (Rr. Shaft; Rr.)	UJ492-10
	U-Joint (Wheel Joint) ^⑥	[2] UJ374		U-Joint (Wheel Joint) ^⑥	[2] UJ374
	Brute Force Non Greaseable	UJ374BF		Brute Force Non Greaseable	UJ374BF
	Centering Yoke	UJ607		Centering Yoke	UJ607
	H Yoke	UJ647		H Yoke	UJ647

Chevrolet/GMC Truck 1 1/2 ton, 2 ton, 2 1/2 ton

Drive Shaft (4 X 2)

U-Joint

2020-2009 Express & Savana 4500: [Type 2]

U-Joint (Front) ^①	UJ351A
Brute Force Non Greaseable	UJ351ABF
U-Joint (Center) ^②	UJ351A
Brute Force Non Greaseable	UJ351ABF
U-Joint (Rear) ^③	UJ351A
Brute Force Non Greaseable	UJ351ABF
2009-2003 2 Joint Shaft w/ 4.5" Yokes: [Type 1]	
U-Joint (Front) ^①	UJ351
(For Aluminum Drive Shaft)	UJ351C
Brute Force Non Greaseable	UJ351BF
Clamp Kit (Front)	UJ351-10
U-Joint (Rear) ^②	UJ351
(For Aluminum Drive Shaft)	UJ351C
Brute Force Non Greaseable	UJ351BF
Clamp Kit (Rear)	UJ351-10

Drive Shaft (4 X 2) (Cont.)

U-Joint (Cont.)

2009-2003 2 Joint Shaft w/ 5.25" Yokes: [Type 1]

U-Joint (Front) ^①	UJ358
Brute Force Non Greaseable	UJ358BF
Clamp Kit (Front)	UJ351-10
U-Joint (Rear) ^②	UJ358
Brute Force Non Greaseable	UJ358BF
Clamp Kit (Rear)	UJ351-10

(Continued)

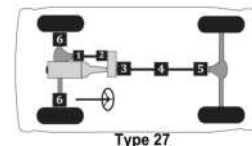
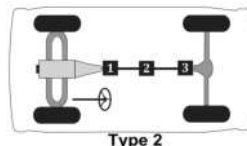
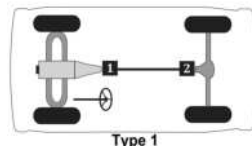

Passenger cars, light & medium trucks

Chevrolet/GMC Truck 1 1/2 ton, 2 ton, 2 1/2 ton -- (Cont.)

MFG./YEAR	MODEL & LOCATION	PART NO.	MFG./YEAR	MODEL & LOCATION	PART NO.
Drive Shaft (4 X 2) (Cont.)			Drive Shaft (4 X 2) (Cont.)		
U-Joint (Cont.)			U-Joint (Cont.)		
2009-2003 3 Joint Shaft w/ 4.5" Yoke: [Type 2]			2009-2003 4 Joint Shaft w/ 5.25" Yoke: [Type 3]		
	U-Joint (Front)Ⓚ	UJ351		U-Joint (Front)Ⓚ	UJ358
	(For Aluminum Drive Shaft)	UJ351C		<i>Brute Force Non Greaseable</i>	UJ358BF
	<i>Brute Force Non Greaseable</i>	UJ351BF		Clamp Kit (Front)	UJ351-10
	Clamp Kit (Front)	UJ351-10		U-Joint (Center; Front)Ⓛ	UJ358
	U-Joint (Center)Ⓛ	UJ351		<i>Brute Force Non Greaseable</i>	UJ358BF
	(For Aluminum Drive Shaft)	UJ351C		Clamp Kit (Center; Front)	UJ351-10
	<i>Brute Force Non Greaseable</i>	UJ351BF		U-Joint (Center; Rear)Ⓛ	UJ358
	Clamp Kit (Center)	UJ351-10		<i>Brute Force Non Greaseable</i>	UJ358BF
	U-Joint (Rear)Ⓛ	UJ351		Clamp Kit (Center; Rear)	UJ351-10
	(For Aluminum Drive Shaft)	UJ351C		U-Joint (Rear)Ⓛ	UJ358
	<i>Brute Force Non Greaseable</i>	UJ351BF		<i>Brute Force Non Greaseable</i>	UJ358BF
	Clamp Kit (Rear)	UJ351-10		Clamp Kit (Rear)	UJ351-10
	2009-2003 3 Joint Shaft w/ 5.25" Yoke: [Type 2]		Drive Shaft (4 X 4)		
	U-Joint (Front)Ⓚ	UJ358	U-Joint		
	<i>Brute Force Non Greaseable</i>	UJ358BF	2009-2005 C4500 & C5500 w/ 2 Joint Rr. Shaft:		
	Clamp Kit (Front)	UJ351-10	[Type 34]		
	U-Joint (Center)Ⓛ	UJ358		U-Joint (Frt. Shaft; Frt.)Ⓚ	UJ330
	<i>Brute Force Non Greaseable</i>	UJ358BF		<i>Brute Force Greaseable</i>	UJ295
	Clamp Kit (Center)	UJ351-10		(For Aluminum Drive Shaft)	UJ330C
	U-Joint (Rear)Ⓛ	UJ358		Clamp Kit (Frt. Shaft; Frt.)	UJ331-10
	<i>Brute Force Non Greaseable</i>	UJ358BF		U-Joint (Frt. Shaft; Rr.)Ⓛ	[2] UJ331
	Clamp Kit (Rear)	UJ351-10		<i>Brute Force Greaseable</i>	UJ232
	2009-2003 4 Joint Shaft w/ 4.5" Yoke: [Type 3]			<i>Brute Force Non Greaseable</i>	UJ231
	U-Joint (Front)Ⓚ	UJ351		(For Aluminum Drive Shaft)	UJ331C
	(For Aluminum Drive Shaft)	UJ351C		U-Joint (Intmd. Shaft; Frt.)Ⓛ	UJ351
	<i>Brute Force Non Greaseable</i>	UJ351BF		(For Aluminum Drive Shaft)	UJ351C
	Clamp Kit (Front)	UJ351-10		<i>Brute Force Non Greaseable</i>	UJ351BF
	U-Joint (Center; Front)Ⓛ	UJ351		Clamp Kit (Intmd. Shaft; Frt.)	UJ351-10
	(For Aluminum Drive Shaft)	UJ351C		U-Joint (Intmd. Shaft; Rr.)Ⓛ	UJ351
	<i>Brute Force Non Greaseable</i>	UJ351BF		(For Aluminum Drive Shaft)	UJ351C
	Clamp Kit (Center; Front)	UJ351-10		<i>Brute Force Non Greaseable</i>	UJ351BF
	U-Joint (Center; Rear)Ⓛ	UJ351		Clamp Kit (Intmd. Shaft; Rr.)	UJ351-10
	(For Aluminum Drive Shaft)	UJ351C		U-Joint (Rr. Shaft; Frt.)Ⓛ	UJ351
	<i>Brute Force Non Greaseable</i>	UJ351BF		(For Aluminum Drive Shaft)	UJ351C
	Clamp Kit (Center; Rear)	UJ351-10		<i>Brute Force Non Greaseable</i>	UJ351BF
	U-Joint (Rear)Ⓛ	UJ351		Clamp Kit (Rr. Shaft; Frt.)	UJ351-10
	(For Aluminum Drive Shaft)	UJ351C		U-Joint (Rr. Shaft; Rr.)Ⓛ	UJ351
	<i>Brute Force Non Greaseable</i>	UJ351BF		(For Aluminum Drive Shaft)	UJ351C
	Clamp Kit (Rear)	UJ351-10		<i>Brute Force Non Greaseable</i>	UJ351BF
				Clamp Kit (Rr. Shaft; Rr.)	UJ351-10
				U-Joint (Wheel Joint)Ⓛ	[2] UJ424
				Centering Ball Kit	UJ617
				H Yoke	UJ650
					(Continued)

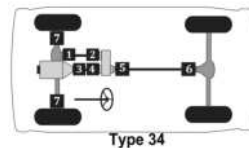
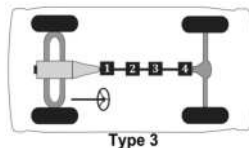
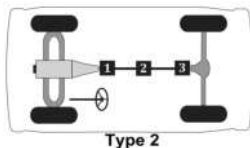

Passenger cars, light & medium trucks

(Cont.) -- Chevrolet/GMC Truck 1 1/2 ton, 2 ton, 2 1/2 ton

MFG./YEAR	MODEL & LOCATION	PART NO.	MFG./YEAR	MODEL & LOCATION	PART NO.
Drive Shaft (4 X 4) (Cont.) U-Joint (Cont.)			Drive Shaft (4 X 4) (Cont.) U-Joint (Cont.)		
			2009-2005 C4500 & C5500 w/ 3 Joint Rr. Shaft:		
			[Type 35]		
			U-Joint (Frnt. Shaft; Frt.) ①		
			Brute Force GreaseableUJ330		
			(For Aluminum Drive Shaft)UJ330C		
			Clamp Kit (Frnt. Shaft; Frt.)UJ331-10		
			U-Joint (Frnt. Shaft; Rr.) ②		
			Brute Force GreaseableUJ232		
			Brute Force Non GreaseableUJ231		
			(For Aluminum Drive Shaft)UJ331C		
			U-Joint (Intmd. Shaft; Frt.) ③		
			(For Aluminum Drive Shaft)UJ351C		
			Brute Force Non GreaseableUJ351BF		
			Clamp Kit (Intmd. Shaft; Frt.)UJ351-10		
			U-Joint (Intmd. Shaft; Rr.) ④		
			(For Aluminum Drive Shaft)UJ351C		
			Brute Force Non GreaseableUJ351BF		
			Clamp Kit (Intmd. Shaft; Rr.)UJ351-10		
			U-Joint (Rr. Shaft; Frt.) ⑤		
			(For Aluminum Drive Shaft)UJ351C		
			Brute Force Non GreaseableUJ351BF		
			Clamp Kit (Rr. Shaft; Frt.)UJ351-10		
			U-Joint (Rr. Shaft; Ctr.) ⑥		
			(For Aluminum Drive Shaft)UJ351C		
			Brute Force Non GreaseableUJ351BF		
			Clamp Kit (Rr. Shaft; Ctr.)UJ351-10		

Chrysler CUV Aspen

Drive Shaft (2 W/D) U-Joint			Drive Shaft (4 W/D) U-Joint		
2009-2007 All: [Type 1]			2009-2007 All: [Type 15]		
U-Joint (Front) ①			U-Joint (Frnt. Shaft; Frt.) ①		
Brute Force GreaseableUJ534G			Brute Force GreaseableUJ280		
Brute Force Non GreaseableUJ234			Brute Force Non GreaseableUJ269		
U-Joint (Rear) ②			U-Joint (Rr. Shaft; Frt.) ②		
Brute Force GreaseableUJ534G			Brute Force GreaseableUJ235		
Brute Force Non GreaseableUJ234			Brute Force Non GreaseableUJ234		

Chrysler CUV Pacifica (thru 2008)

Drive Shaft U-Joint	
2008-2004 All:	
Flex CouplerVKJF98014

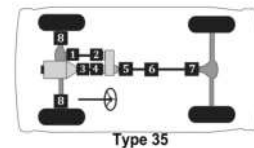
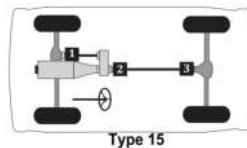
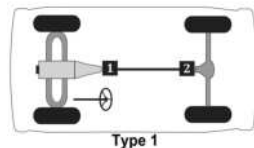

Passenger cars, light & medium trucks

Dodge Truck D-50 Pickup, Power Ram 50, Raider, Ram 50

MFG./YEAR	MODEL & LOCATION	PART NO.	MFG./YEAR	MODEL & LOCATION	PART NO.
Drive Shaft (2 W/D)			Drive Shaft (4 W/D)		
U-Joint			U-Joint		
1993-1990 Ram 50 w/ 2 Joint Shaft & Auto. Trans.: [Type 1]			1993-1990 Ram 50 w/ Reg. Cab & Std. Bed: [Type 13]		
U-Joint (Front) ①		UJ398	U-Joint (Fr. Shaft; Frt.) ①		UJ398
U-Joint (Rear) ②		UJ398	U-Joint (Fr. Shaft; Rr.) ②		UJ398
1993-1990 Ram 50 w/ 2 Joint Shaft & Man. Trans.: [Type 1]			U-Joint (Rr. Shaft; Frt.) ③		
U-Joint (Front) ①		UJ399	U-Joint (Rr. Shaft; Rr.) ④		UJ450
U-Joint (Rear) ②		UJ399	1993-1990 Ram 50 w/ Ext. Cab: [Type 14]		
1993-1989 Ram 50 w/ 3 Joint Shaft & Auto. Trans.: [Type 2]			U-Joint (Fr. Shaft; Frt.) ①		
U-Joint (Front) ①		UJ398	U-Joint (Fr. Shaft; Rr.) ②		UJ398
U-Joint (Center) ②		UJ398	U-Joint (Rr. Shaft; Frt.) ③		UJ450
U-Joint (Rear) ③		UJ398	U-Joint (Rr. Shaft; Rr.) ④		UJ450
1993-1989 Ram 50 w/ 3 Joint Shaft & Man. Trans.: [Type 2]			1993-1990 Ram 50 w/ Long Bed: [Type 14]		
U-Joint (Front) ①		UJ399	U-Joint (Fr. Shaft; Frt.) ①		UJ398
U-Joint (Center) ②		UJ399	U-Joint (Fr. Shaft; Rr.) ②		UJ398
U-Joint (Rear) ③		UJ399	U-Joint (Rr. Shaft; Frt.) ③		UJ450
1989-1987 Ram 50 w/ 2 Joint Shaft & 2.0L Eng.: [Type 1]			U-Joint (Rr. Shaft; Rr.) ④		
U-Joint (Front) ①		UJ398	1989 Raider w/ 3.0L Eng.: [Type 13]		
U-Joint (Rear) ②		UJ398	U-Joint (Fr. Shaft; Frt.) ①		UJ398
1989-1987 Ram 50 w/ 2 Joint Shaft & 2.6L Eng.: [Type 1]			U-Joint (Fr. Shaft; Rr.) ②		UJ398
U-Joint (Front) ①		UJ399	U-Joint (Rr. Shaft; Frt.) ③		UJ450
U-Joint (Rear) ②		UJ399	U-Joint (Rr. Shaft; Rr.) ④		UJ450
1988-1987 Ram 50 w/ 3 Joint Shaft: [Type 2]			1989-1987 Raider w/ 2.6L Eng.: [Type 13]		
U-Joint (Front) ①		UJ399	U-Joint (Fr. Shaft; Frt.) ①		UJ398
U-Joint (Center) ②		UJ399	U-Joint (Fr. Shaft; Rr.) ②		UJ398
U-Joint (Rear) ③		UJ399	U-Joint (Rr. Shaft; Frt.) ③		UJ399
1986-1983 Ram 50 w/ 2.0L Eng.: [Type 2]			U-Joint (Rr. Shaft; Rr.) ④		
U-Joint (Front) ①		UJ398	1989-1983 Ram 50 & Power Ram 50: [Type 13]		
U-Joint (Center) ②		UJ398	U-Joint (Fr. Shaft; Frt.) ①		UJ398
U-Joint (Rear) ③		UJ398	U-Joint (Fr. Shaft; Rr.) ②		UJ398
1986-1983 Ram 50 w/ 2.3L & 2.6L Eng.: [Type 2]			U-Joint (Rr. Shaft; Frt.) ③		
U-Joint (Front) ①		UJ399	U-Joint (Rr. Shaft; Rr.) ④		UJ399
U-Joint (Center) ②		UJ399	1982 D50: [Type 13]		
U-Joint (Rear) ③		UJ399	U-Joint (Fr. Shaft; Frt.) ①		UJ398
1982-1979 D50 w/ 2.0L Eng.: [Type 1]			U-Joint (Fr. Shaft; Rr.) ②		UJ398
U-Joint (Front) ①		UJ398	U-Joint (Rr. Shaft; Frt.) ③		UJ399
U-Joint (Rear) ②		UJ398	U-Joint (Rr. Shaft; Rr.) ④		UJ399
1982-1979 D50 w/ 2.6L Eng.: [Type 1]			1981-1979 D50: [Type 25]		
U-Joint (Front) ①		UJ399	U-Joint (Fr. Shaft; Frt.) ①		UJ398
U-Joint (Rear) ②		UJ399	U-Joint (Fr. Shaft; Rr.) ②		UJ398
			U-Joint (Intmd. Shaft; Frt.) ⑤		UJ398
			U-Joint (Intmd. Shaft; Rr.) ⑥		UJ398
			U-Joint (Rr. Shaft; Frt.) ③		UJ398
			U-Joint (Rr. Shaft; Rr.) ④		UJ398

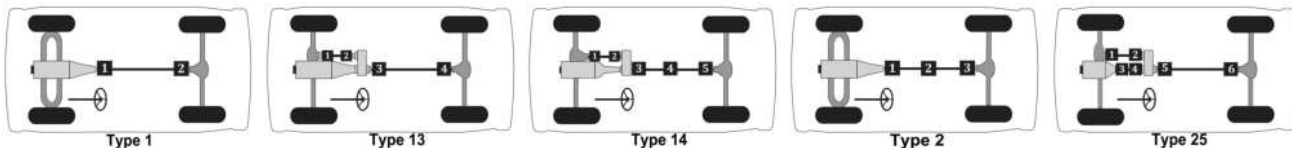

220 ▲ For Use w/ 1.063" Bearing Cap Application. ⊙ For Use w/ 1.188" Bearing Cap Application. ◇ For Use w/ Inner Lock Ring Application on Half Shaft. □ For Use w/ Outer Lock Ring Application on Half Shaft.



Passenger cars, light & medium trucks

Dodge Truck Full Size Vans, 1/2 ton van, 3/4 ton van, 1 ton van

MFG./YEAR	MODEL & LOCATION	PART NO.	MFG./YEAR	MODEL & LOCATION	PART NO.
Drive Shaft			Drive Shaft (Cont.)		
U-Joint			U-Joint (Cont.)		
2003-2000 R1500 Van & R2500 Van: [Type 1]			1998 B1500 & B2500 w/ 127" Wheel Base:		
U-Joint (Front) ①UJ354			[Type 1]		
<i>Brute Force Greaseable</i>UJ270			U-Joint (Front) ①UJ354		
<i>Brute Force Non Greaseable</i>UJ254			<i>Brute Force Greaseable</i>UJ270		
(For Aluminum Drive Shaft)UJ354C			<i>Brute Force Non Greaseable</i>UJ254		
U-Joint (Rear) ②UJ354			(For Aluminum Drive Shaft)UJ354C		
<i>Brute Force Greaseable</i>UJ270			U-Joint (Rear) ②UJ458		
<i>Brute Force Non Greaseable</i>UJ254			(For Aluminum Drive Shaft)UJ458C		
(For Aluminum Drive Shaft)UJ354C			<i>Brute Force Non Greaseable</i>UJ458BF		
2003-2000 R3500 Van w/ Chrysler Axle: [Type 1]			1998 B3500 w/ Dana 60 Axle: [Type 1]		
U-Joint (Front) ①UJ354			U-Joint (Front) ①UJ330		
<i>Brute Force Greaseable</i>UJ270			<i>Brute Force Greaseable</i>UJ295		
<i>Brute Force Non Greaseable</i>UJ254			(For Aluminum Drive Shaft)UJ330C		
(For Aluminum Drive Shaft)UJ354C			Clamp Kit (Front)UJ331-10		
U-Joint (Rear) ②UJ354			U-Joint (Rear) ②UJ330		
<i>Brute Force Greaseable</i>UJ270			<i>Brute Force Greaseable</i>UJ295		
<i>Brute Force Non Greaseable</i>UJ254			(For Aluminum Drive Shaft)UJ330C		
(For Aluminum Drive Shaft)UJ354C			Clamp Kit (Rear)UJ331-10		
2003-1999 R3500 Van w/ Dana 60 Axle: [Type 1]			1998 B3500 w/ Chrysler Axle & 109" Wheel		
U-Joint (Front) ①UJ330			Base: [Type 1]		
<i>Brute Force Greaseable</i>UJ295			U-Joint (Front) ①UJ316		
(For Aluminum Drive Shaft)UJ330C			<i>Brute Force Greaseable</i>UJ248		
Clamp Kit (Front)UJ331-10			Clamp Kit (Front)UJ316-10		
U-Joint (Rear) ②UJ330			U-Joint (Rear) ②UJ316		
<i>Brute Force Greaseable</i>UJ295			<i>Brute Force Greaseable</i>UJ248		
(For Aluminum Drive Shaft)UJ330C			Clamp Kit (Rear)UJ316-10		
Clamp Kit (Rear)UJ331-10			1998 B3500 w/ Chrysler Axle & 127" Wheel		
1999 R1500 Van & R2500 Van: [Type 1]			Base: [Type 1]		
U-Joint (Front) ①UJ354			U-Joint (Front) ①UJ354		
<i>Brute Force Greaseable</i>UJ270			<i>Brute Force Greaseable</i>UJ270		
<i>Brute Force Non Greaseable</i>UJ254			<i>Brute Force Non Greaseable</i>UJ254		
(For Aluminum Drive Shaft)UJ354C			(For Aluminum Drive Shaft)UJ354C		
U-Joint (Rear) ②UJ458			U-Joint (Rear) ②UJ458		
(For Aluminum Drive Shaft)UJ458C			(For Aluminum Drive Shaft)UJ458C		
<i>Brute Force Non Greaseable</i>UJ458BF			<i>Brute Force Non Greaseable</i>UJ458BF		
1999 R3500 Van w/ Chrysler Axle: [Type 1]			1997-1994 B150, B250, B1500 & B2500: [Type 1]		
U-Joint (Front) ①UJ354			U-Joint (Front) ①UJ316		
<i>Brute Force Greaseable</i>UJ270			<i>Brute Force Greaseable</i>UJ248		
<i>Brute Force Non Greaseable</i>UJ254			Clamp Kit (Front)UJ316-10		
(For Aluminum Drive Shaft)UJ354C			U-Joint (Rear) ②UJ316		
U-Joint (Rear) ②UJ458			<i>Brute Force Greaseable</i>UJ248		
(For Aluminum Drive Shaft)UJ458C			Clamp Kit (Rear)UJ316-10		
<i>Brute Force Non Greaseable</i>UJ458BF			1997-1994 B350 & B3500 w/ Inner Lock Rings:		
1998 B1500 & B2500 w/ 109" Wheel Base:			[Type 1]		
[Type 1]			U-Joint (Front) ①UJ316		
U-Joint (Front) ①UJ316			<i>Brute Force Greaseable</i>UJ248		
<i>Brute Force Greaseable</i>UJ248			Clamp Kit (Front)UJ316-10		
Clamp Kit (Front)UJ316-10			U-Joint (Rear) ②UJ316		
U-Joint (Rear) ②UJ316			<i>Brute Force Greaseable</i>UJ248		
<i>Brute Force Greaseable</i>UJ248			Clamp Kit (Rear)UJ316-10		
Clamp Kit (Rear)UJ316-10			(Continued)		

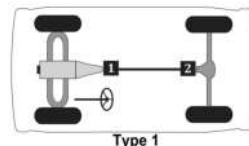

Passenger cars, light & medium trucks

Dodge Truck Full Size Vans, 1/2 ton van, 3/4 ton van, 1 ton van -- (Cont.)



MFG./YEAR	MODEL & LOCATION	PART NO.	MFG./YEAR	MODEL & LOCATION	PART NO.
-----------	------------------	----------	-----------	------------------	----------

Drive Shaft (Cont.)



U-Joint (Cont.)

1997-1994 B350 & B3500 w/ Outer Lock Rings:



[Type 1]

U-Joint (Front) 	UJ330
Brute Force Greaseable	UJ295
(For Aluminum Drive Shaft)	UJ330C
Clamp Kit (Front)	UJ331-10
U-Joint (Rear) 	UJ330
Brute Force Greaseable	UJ295
(For Aluminum Drive Shaft)	UJ330C
Clamp Kit (Rear)	UJ331-10



1993-1992 B150 & B250 w/ 2.125" Yoke: [Type 1]

U-Joint (Front) 	UJ317
Brute Force Greaseable	UJ246
Clamp Kit (Front)	UJ318-10
U-Joint (Rear) 	UJ317
Brute Force Greaseable	UJ246
Clamp Kit (Rear)	UJ318-10



1993-1992 B150 & B250 w/ 2.625" Yoke: [Type 1]

U-Joint (Front) 	UJ317
Brute Force Greaseable	UJ246
Clamp Kit (Front)	UJ318-10
U-Joint (Rear) 	UJ316
Brute Force Greaseable	UJ248
Clamp Kit (Rear)	UJ316-10



1993-1992 B350: [Type 1]

U-Joint (Front) 	UJ317
Brute Force Greaseable	UJ246
Clamp Kit (Front)	UJ318-10
U-Joint (Rear) 	UJ316
Brute Force Greaseable	UJ248
Clamp Kit (Rear)	UJ316-10

1991-1988 B150 & B250: [Type 1]

U-Joint (Front) 	UJ317
Brute Force Greaseable	UJ246
Clamp Kit (Front)	UJ318-10
U-Joint (Rear) 	UJ317
Brute Force Greaseable	UJ246
Clamp Kit (Rear)	UJ318-10



1991-1988 B350 w/ 2 Joint Shaft: [Type 1]

U-Joint (Front) 	UJ317
Brute Force Greaseable	UJ246
Clamp Kit (Front)	UJ318-10
U-Joint (Rear) 	UJ317
Brute Force Greaseable	UJ246
Clamp Kit (Rear)	UJ318-10



Drive Shaft (Cont.)

U-Joint (Cont.)



1991-1988 B350 w/ 3 Joint Shaft: [Type 2]

U-Joint (Front) 	UJ317
Brute Force Greaseable	UJ246
Clamp Kit (Front)	UJ318-10
U-Joint (Center) 	UJ317
Brute Force Greaseable	UJ246
Clamp Kit (Center)	UJ318-10
U-Joint (Rear) 	UJ317
Brute Force Greaseable	UJ246
Clamp Kit (Rear)	UJ318-10



1987-1982 B150 & B250: [Type 1]

U-Joint (Front) 	UJ315G
Brute Force Greaseable	UJ246
Clamp Kit	UJ318-10
U-Joint (Rear) 	UJ315G
Brute Force Greaseable	UJ246
Clamp Kit	UJ318-10



1987-1982 B350 w/ 2 Joint Shaft: [Type 1]

U-Joint (Front) 	UJ315G
Brute Force Greaseable	UJ246
Clamp Kit	UJ318-10
U-Joint (Rear) 	UJ315G
Brute Force Greaseable	UJ246
Clamp Kit	UJ318-10



1987-1982 B350 w/ 3 Joint Shaft: [Type 2]

U-Joint (Front) 	UJ315G
Brute Force Greaseable	UJ246
Clamp Kit	UJ318-10
U-Joint (Center) 	UJ315G
Brute Force Greaseable	UJ246
Clamp Kit	UJ318-10
U-Joint (Rear) 	UJ315G
Brute Force Greaseable	UJ246
Clamp Kit	UJ318-10

1981-1978 B100 & B150 w/ 2.125" Yoke: [Type 1]

U-Joint (Front) 	UJ315G
Brute Force Greaseable	UJ246
Clamp Kit	UJ318-10
U-Joint (Rear) 	UJ315G
Brute Force Greaseable	UJ246
Clamp Kit	UJ318-10

1981-1978 B100 & B150 w/ 2.625" Yoke: [Type 1]

U-Joint (Front) 	UJ317
Brute Force Greaseable	UJ246
U-Joint (Rear) 	UJ316
Brute Force Greaseable	UJ248
Clamp Kit (Rear)	UJ316-10

(Continued)

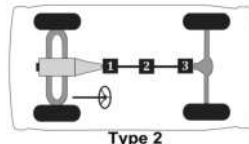
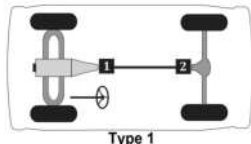

Passenger cars, light & medium trucks

(Cont.) -- Dodge Truck Full Size Vans, 1/2 ton van, 3/4 ton van, 1 ton van

MFG./YEAR	MODEL & LOCATION	PART NO.	MFG./YEAR	MODEL & LOCATION	PART NO.
Drive Shaft (Cont.)			Drive Shaft (Cont.)		
U-Joint (Cont.)			U-Joint (Cont.)		
1981-1974 B200 & B250 w/ 2.125" Yoke: [Type 1]			1977-1971 B100: [Type 1]		
U-Joint (Front)Ⓢ		UJ315G	U-Joint (Front)Ⓢ		UJ315G
Brute Force Greaseable		UJ246	Brute Force Greaseable		UJ246
Clamp Kit		UJ318-10	Clamp Kit		UJ318-10
U-Joint (Rear)Ⓢ		UJ315G	U-Joint (Rear)Ⓢ		UJ315G
Brute Force Greaseable		UJ246	Brute Force Greaseable		UJ246
Clamp Kit		UJ318-10	Clamp Kit		UJ318-10
1981-1974 B200 & B250 w/ 2.625" Yoke: [Type 1]			1973-1971 B200 w/ 2 Joint Shaft: [Type 1]		
U-Joint (Front)Ⓢ		UJ317	U-Joint (Front)Ⓢ		UJ315G
Brute Force Greaseable		UJ246	Brute Force Greaseable		UJ246
U-Joint (Rear)Ⓢ		UJ316	U-Joint (Rear)Ⓢ		UJ315G
Brute Force Greaseable		UJ248	Brute Force Greaseable		UJ246
Clamp Kit (Rear)		UJ316-10	Clamp Kit		UJ318-10
1981-1971 B300 & B350 w/ 2 Joint Shaft & 2.125" Yoke: [Type 1]			1973-1971 B200 w/ 3 Joint Shaft: [Type 2]		
U-Joint (Front)Ⓢ		UJ315G	U-Joint (Front)Ⓢ		UJ315G
Brute Force Greaseable		UJ246	Brute Force Greaseable		UJ246
Clamp Kit		UJ318-10	Clamp Kit		UJ318-10
U-Joint (Rear)Ⓢ		UJ315G	U-Joint (Center)Ⓢ		UJ315G
Brute Force Greaseable		UJ246	Brute Force Greaseable		UJ246
Clamp Kit		UJ318-10	Clamp Kit		UJ318-10
1981-1971 B300 & B350 w/ 2 Joint Shaft & 2.625" Yoke: [Type 1]			U-Joint (Rear)Ⓢ		
U-Joint (Front)Ⓢ		UJ316	Brute Force Greaseable		UJ246
Brute Force Greaseable		UJ248	Clamp Kit		UJ318-10
Clamp Kit (Front)		UJ316-10	1970-1964 A100 Van: [Type 1]		
U-Joint (Rear)Ⓢ		UJ316	U-Joint (Front)Ⓢ		UJ315G
Brute Force Greaseable		UJ248	Brute Force Greaseable		UJ246
Clamp Kit (Rear)		UJ316-10	Clamp Kit		UJ318-10
1981-1971 B300 & B350 w/ 3 Joint Shaft & 2.125" Yoke: [Type 2]			U-Joint (Rear)Ⓢ		UJ315G
U-Joint (Front)Ⓢ		UJ315G	Brute Force Greaseable		UJ246
Brute Force Greaseable		UJ246	Clamp Kit		UJ318-10
Clamp Kit		UJ318-10	1970-1964 A100 Van: [Type 1]		
U-Joint (Center)Ⓢ		UJ315G	U-Joint (Front)Ⓢ		UJ315G
Brute Force Greaseable		UJ246	Brute Force Greaseable		UJ246
Clamp Kit		UJ318-10	Clamp Kit		UJ318-10
U-Joint (Rear)Ⓢ		UJ315G	U-Joint (Rear)Ⓢ		UJ315G
Brute Force Greaseable		UJ246	Brute Force Greaseable		UJ246
Clamp Kit		UJ318-10	Clamp Kit		UJ318-10
1981-1971 B300 & B350 w/ 3 Joint Shaft & 2.625" Yoke: [Type 2]			1970-1964 A100 Van: [Type 1]		
U-Joint (Front)Ⓢ		UJ316	U-Joint (Front)Ⓢ		UJ315G
Brute Force Greaseable		UJ248	Brute Force Greaseable		UJ246
Clamp Kit (Front)		UJ316-10	Clamp Kit		UJ318-10
U-Joint (Center)Ⓢ		UJ316	U-Joint (Rear)Ⓢ		UJ315G
Brute Force Greaseable		UJ248	Brute Force Greaseable		UJ246
Clamp Kit (Center)		UJ316-10	Clamp Kit		UJ318-10
U-Joint (Rear)Ⓢ		UJ316	1970-1964 A100 Van: [Type 1]		
Brute Force Greaseable		UJ248	U-Joint (Front)Ⓢ		UJ315G
Clamp Kit (Rear)		UJ316-10	Brute Force Greaseable		UJ246

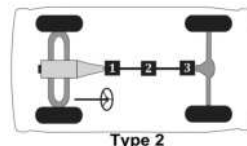
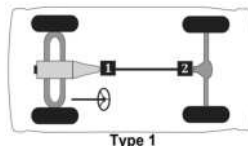

Passenger cars, light & medium trucks

Dodge Truck 1/2 ton

MFG./YEAR	MODEL & LOCATION	PART NO.	MFG./YEAR	MODEL & LOCATION	PART NO.
Drive Shaft (2 W/D)			Drive Shaft (2 W/D) (Cont.)		
U-Joint			U-Joint (Cont.)		
2010-2009 R1500 w/ 2 Joint Shaft & 3.7L Eng.:			2010-2000 Dakota w/ 3 Joint Shaft: [Type 2]		
[Type 1]			U-Joint (Front)Ⓛ UJ354		
U-Joint (Front)Ⓛ UJ354			<i>Brute Force Greaseable</i> UJ270		
<i>Brute Force Greaseable</i> UJ270			<i>Brute Force Non Greaseable</i> UJ254		
<i>Brute Force Non Greaseable</i> UJ254			(For Aluminum Drive Shaft) UJ354C		
(For Aluminum Drive Shaft) UJ354C			U-Joint (Center)Ⓢ UJ354		
U-Joint (Rear)Ⓢ UJ354			<i>Brute Force Greaseable</i> UJ270		
<i>Brute Force Greaseable</i> UJ270			<i>Brute Force Non Greaseable</i> UJ254		
<i>Brute Force Non Greaseable</i> UJ254			(For Aluminum Drive Shaft) UJ354C		
(For Aluminum Drive Shaft) UJ354C			U-Joint (Rear)Ⓢ UJ354		
2010-2009 R1500 w/ 3 Joint Shaft & 3.7L Eng.:			<i>Brute Force Greaseable</i> UJ270		
[Type 2]			<i>Brute Force Non Greaseable</i> UJ254		
U-Joint (Front)Ⓛ UJ354			(For Aluminum Drive Shaft) UJ354C		
<i>Brute Force Greaseable</i> UJ270			2009-2004 Durango: [Type 1]		
<i>Brute Force Non Greaseable</i> UJ254			U-Joint (Front)Ⓛ UJ534G		
(For Aluminum Drive Shaft) UJ354C			<i>Brute Force Greaseable</i> UJ235		
U-Joint (Center)Ⓢ UJ354			<i>Brute Force Non Greaseable</i> UJ234		
<i>Brute Force Greaseable</i> UJ270			U-Joint (Rear)Ⓢ UJ534G		
<i>Brute Force Non Greaseable</i> UJ254			<i>Brute Force Greaseable</i> UJ235		
(For Aluminum Drive Shaft) UJ354C			<i>Brute Force Non Greaseable</i> UJ234		
U-Joint (Rear)Ⓢ UJ354			(For Aluminum Drive Shaft) UJ354C		
<i>Brute Force Greaseable</i> UJ270			2008-2007 R1500 w/ 2 Joint Shaft Exc. Mega Cab:		
<i>Brute Force Non Greaseable</i> UJ254			[Type 1]		
(For Aluminum Drive Shaft) UJ354C			U-Joint (Front)Ⓛ UJ354		
2010-2009 R1500 w/ 4.7L & 5.7L Eng.: [Type 1]			<i>Brute Force Greaseable</i> UJ270		
U-Joint (Front)Ⓛ UJ331			<i>Brute Force Non Greaseable</i> UJ254		
<i>Brute Force Greaseable</i> UJ232			(For Aluminum Drive Shaft) UJ354C		
<i>Brute Force Non Greaseable</i> UJ231			U-Joint (Rear)Ⓢ UJ354		
(For Aluminum Drive Shaft) UJ331C			<i>Brute Force Greaseable</i> UJ270		
U-Joint (Rear)Ⓢ UJ331			<i>Brute Force Non Greaseable</i> UJ254		
<i>Brute Force Greaseable</i> UJ232			(For Aluminum Drive Shaft) UJ354C		
<i>Brute Force Non Greaseable</i> UJ231			2008-2007 R1500 w/ 3 Joint Shaft Exc. Mega Cab:		
(For Aluminum Drive Shaft) UJ331C			[Type 2]		
2010-2000 Dakota w/ 2 Joint Shaft: [Type 1]			U-Joint (Front)Ⓛ UJ354		
U-Joint (Front)Ⓛ UJ354			<i>Brute Force Greaseable</i> UJ270		
<i>Brute Force Greaseable</i> UJ270			<i>Brute Force Non Greaseable</i> UJ254		
<i>Brute Force Non Greaseable</i> UJ254			(For Aluminum Drive Shaft) UJ354C		
(For Aluminum Drive Shaft) UJ354C			U-Joint (Center)Ⓢ UJ354		
U-Joint (Rear)Ⓢ UJ354			<i>Brute Force Greaseable</i> UJ270		
<i>Brute Force Greaseable</i> UJ270			<i>Brute Force Non Greaseable</i> UJ254		
<i>Brute Force Non Greaseable</i> UJ254			(For Aluminum Drive Shaft) UJ354C		
(For Aluminum Drive Shaft) UJ354C			U-Joint (Rear)Ⓢ UJ354		
			<i>Brute Force Greaseable</i> UJ270		
			<i>Brute Force Non Greaseable</i> UJ254		
			(For Aluminum Drive Shaft) UJ354C		
			2008-2006 R1500 w/ Mega Cab: [Type 2]		
			U-Joint (Front)Ⓛ UJ330A		
			<i>Brute Force Greaseable</i> UJ295A		
			U-Joint (Center)Ⓢ UJ330A		
			<i>Brute Force Greaseable</i> UJ295A		
			U-Joint (Rear)Ⓢ UJ330A		
			<i>Brute Force Greaseable</i> UJ295A		

(Continued)

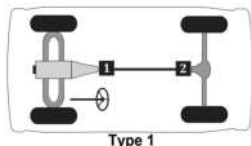

Type 1

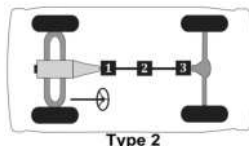

Type 2

MFG./YEAR	MODEL & LOCATION	PART NO.	MFG./YEAR	MODEL & LOCATION	PART NO.
Drive Shaft (2 W/D) (Cont.)			Drive Shaft (2 W/D) (Cont.)		
U-Joint (Cont.)			U-Joint (Cont.)		
2006-2005 R1500 SRT-10 w/ Reg. Cab: [Type 1]			2004 R1500 SRT-10: [Type 1]		
	U-Joint (Front)⓪	UJ331		U-Joint (Front)⓪	UJ330
	<i>Brute Force Greaseable</i>	UJ232		<i>Brute Force Greaseable</i>	UJ295
	<i>Brute Force Non Greaseable</i>	UJ231		(For Aluminum Drive Shaft)	UJ330C
	(For Aluminum Drive Shaft)	UJ331C		Clamp Kit (Front)	UJ331-10
	Clamp Kit (Front)	UJ331-10		U-Joint (Rear)⓪	UJ330
	U-Joint (Rear)⓪	UJ331		<i>Brute Force Greaseable</i>	UJ295
	<i>Brute Force Greaseable</i>	UJ232		(For Aluminum Drive Shaft)	UJ330C
	<i>Brute Force Non Greaseable</i>	UJ231		Clamp Kit (Rear)	UJ331-10
	(For Aluminum Drive Shaft)	UJ331C		2003-2000 Durango: [Type 1]	
	Clamp Kit (Rear)	UJ331-10		U-Joint (Front)⓪	UJ354
	2006-2005 R1500 SRT-10 w/ Quad Cab: [Type 2]			<i>Brute Force Greaseable</i>	UJ270
	U-Joint (Front)⓪	UJ330		<i>Brute Force Non Greaseable</i>	UJ254
	<i>Brute Force Greaseable</i>	UJ295		(For Aluminum Drive Shaft)	UJ354C
	(For Aluminum Drive Shaft)	UJ330C		U-Joint (Rear)⓪	UJ354
	Clamp Kit (Front)	UJ331-10		<i>Brute Force Greaseable</i>	UJ270
	U-Joint (Center)⓪	UJ330		<i>Brute Force Non Greaseable</i>	UJ254
	<i>Brute Force Greaseable</i>	UJ295		(For Aluminum Drive Shaft)	UJ354C
	(For Aluminum Drive Shaft)	UJ330C		2003-2000 R1500 w/ 2 Joint Shaft: [Type 1]	
	Clamp Kit (Center)	UJ331-10		U-Joint (Front)⓪	UJ354
	U-Joint (Rear)⓪	UJ330		<i>Brute Force Greaseable</i>	UJ270
	<i>Brute Force Greaseable</i>	UJ295		<i>Brute Force Non Greaseable</i>	UJ254
	(For Aluminum Drive Shaft)	UJ330C		(For Aluminum Drive Shaft)	UJ354C
	Clamp Kit (Rear)	UJ331-10		U-Joint (Rear)⓪	UJ354
	2006-2004 R1500 w/ 2 Joint Shaft Exc. Mega Cab			<i>Brute Force Greaseable</i>	UJ270
	& SRT-10: [Type 1]			<i>Brute Force Non Greaseable</i>	UJ254
	U-Joint (Front)⓪	UJ354		(For Aluminum Drive Shaft)	UJ354C
	<i>Brute Force Greaseable</i>	UJ270		2003-2000 R1500 w/ 3 Joint Shaft: [Type 2]	
	<i>Brute Force Non Greaseable</i>	UJ254		U-Joint (Front)⓪	UJ354
	(For Aluminum Drive Shaft)	UJ354C		<i>Brute Force Greaseable</i>	UJ270
	U-Joint (Rear)⓪	UJ354		<i>Brute Force Non Greaseable</i>	UJ254
	<i>Brute Force Greaseable</i>	UJ270		(For Aluminum Drive Shaft)	UJ354C
	<i>Brute Force Non Greaseable</i>	UJ254		U-Joint (Center)⓪	UJ354
	(For Aluminum Drive Shaft)	UJ354C		<i>Brute Force Greaseable</i>	UJ270
	2006-2004 R1500 w/ 3 Joint Shaft Exc. Mega Cab			<i>Brute Force Non Greaseable</i>	UJ254
	& SRT-10: [Type 2]			(For Aluminum Drive Shaft)	UJ354C
	U-Joint (Front)⓪	UJ354		U-Joint (Rear)⓪	UJ354
	<i>Brute Force Greaseable</i>	UJ270		<i>Brute Force Greaseable</i>	UJ270
	<i>Brute Force Non Greaseable</i>	UJ254		<i>Brute Force Non Greaseable</i>	UJ254
	(For Aluminum Drive Shaft)	UJ354C		(For Aluminum Drive Shaft)	UJ354C
	U-Joint (Center)⓪	UJ354		1999 Dakota w/ 2 Joint Shaft: [Type 1]	
	<i>Brute Force Greaseable</i>	UJ270		U-Joint (Front)⓪	UJ354
	<i>Brute Force Non Greaseable</i>	UJ254		<i>Brute Force Greaseable</i>	UJ270
	(For Aluminum Drive Shaft)	UJ354C		<i>Brute Force Non Greaseable</i>	UJ254
	U-Joint (Rear)⓪	UJ354		(For Aluminum Drive Shaft)	UJ354C
	<i>Brute Force Greaseable</i>	UJ270		U-Joint (Rear)⓪	UJ458
	<i>Brute Force Non Greaseable</i>	UJ254		(For Aluminum Drive Shaft)	UJ458C
	(For Aluminum Drive Shaft)	UJ354C		<i>Brute Force Non Greaseable</i>	UJ458BF

(Continued)

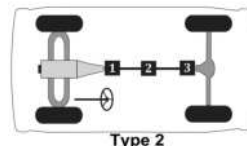
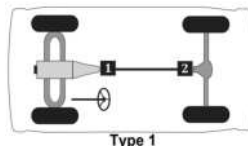

Passenger cars, light & medium trucks

Dodge Truck 1/2 ton -- (Cont.)

MFG./YEAR	MODEL & LOCATION	PART NO.	MFG./YEAR	MODEL & LOCATION	PART NO.
Drive Shaft (2 W/D) (Cont.)			Drive Shaft (2 W/D) (Cont.)		
U-Joint (Cont.)			U-Joint (Cont.)		
1999	Dakota w/ 3 Joint Shaft: [Type 2]		1998	R1500 w/ 2 Joint Shaft & Auto. Trans.:	
	U-Joint (Front)Ⓛ	UJ354		[Type 1]	
	<i>Brute Force Greaseable</i>	UJ270		U-Joint (Front)Ⓛ	UJ354
	<i>Brute Force Non Greaseable</i>	UJ254		<i>Brute Force Greaseable</i>	UJ270
	(For Aluminum Drive Shaft)	UJ354C		<i>Brute Force Non Greaseable</i>	UJ254
	U-Joint (Center)Ⓢ	UJ354		(For Aluminum Drive Shaft)	UJ354C
	<i>Brute Force Greaseable</i>	UJ270		U-Joint (Rear)Ⓢ	UJ458
	<i>Brute Force Non Greaseable</i>	UJ254		(For Aluminum Drive Shaft)	UJ458C
	(For Aluminum Drive Shaft)	UJ354C		<i>Brute Force Non Greaseable</i>	UJ458BF
	U-Joint (Rear)Ⓢ	UJ458	1998	R1500 w/ 2 Joint Shaft & Man. Trans.:	
	(For Aluminum Drive Shaft)	UJ458C		[Type 1]	
	<i>Brute Force Non Greaseable</i>	UJ458BF		U-Joint (Front)Ⓛ	UJ316
1999	Durango: [Type 1]			<i>Brute Force Greaseable</i>	UJ248
	U-Joint (Front)Ⓛ	UJ316		Clamp Kit (Front)	UJ316-10
	<i>Brute Force Greaseable</i>	UJ248		U-Joint (Rear)Ⓢ	UJ316
	Clamp Kit (Front)	UJ316-10		<i>Brute Force Greaseable</i>	UJ248
	U-Joint (Rear)Ⓢ	UJ316		Clamp Kit (Rear)	UJ316-10
	<i>Brute Force Greaseable</i>	UJ248		1998-1994 Dakota w/ 2 Joint Shaft: [Type 1]	
	Clamp Kit (Rear)	UJ316-10		U-Joint (Front)Ⓛ	UJ316
1999	R1500 w/ Reg. Cab & Short Bed:			<i>Brute Force Greaseable</i>	UJ248
	[Type 1]			Clamp Kit (Front)	UJ316-10
	U-Joint (Front)Ⓛ	UJ354		U-Joint (Rear)Ⓢ	UJ316
	<i>Brute Force Greaseable</i>	UJ270		<i>Brute Force Greaseable</i>	UJ248
	<i>Brute Force Non Greaseable</i>	UJ254		Clamp Kit (Rear)	UJ316-10
	(For Aluminum Drive Shaft)	UJ354C		1998-1994 Dakota w/ 3 Joint Shaft: [Type 2]	
	U-Joint (Rear)Ⓢ	UJ458		U-Joint (Front)Ⓛ	UJ316
	(For Aluminum Drive Shaft)	UJ458C		<i>Brute Force Greaseable</i>	UJ248
	<i>Brute Force Non Greaseable</i>	UJ458BF		Clamp Kit (Front)	UJ316-10
1999	R1500 w/ Reg. Cab & Long Bed:			U-Joint (Center)Ⓢ	UJ316
	[Type 2]			<i>Brute Force Greaseable</i>	UJ248
	U-Joint (Front)Ⓛ	UJ354		Clamp Kit (Center)	UJ316-10
	<i>Brute Force Greaseable</i>	UJ270		U-Joint (Rear)Ⓢ	UJ316
	<i>Brute Force Non Greaseable</i>	UJ254		<i>Brute Force Greaseable</i>	UJ248
	(For Aluminum Drive Shaft)	UJ354C		Clamp Kit (Rear)	UJ316-10
	U-Joint (Center)Ⓢ	UJ354	1998-1994 R1500 w/ 3 Joint Shaft: [Type 2]		
	<i>Brute Force Greaseable</i>	UJ270		U-Joint (Front)Ⓛ	UJ316
	<i>Brute Force Non Greaseable</i>	UJ254		<i>Brute Force Greaseable</i>	UJ248
	(For Aluminum Drive Shaft)	UJ354C		U-Joint (Center)Ⓢ	UJ316
	U-Joint (Rear)Ⓢ	UJ458		<i>Brute Force Greaseable</i>	UJ248
	(For Aluminum Drive Shaft)	UJ458C		U-Joint (Rear)Ⓢ	UJ316
	<i>Brute Force Non Greaseable</i>	UJ458BF		<i>Brute Force Greaseable</i>	UJ248
1999	R1500 w/ Quad Cab: [Type 2]		1997-1994 R1500 w/ 2 Joint Alum. Driveshaft:		
	U-Joint (Front)Ⓛ	UJ354		[Type 1]	
	<i>Brute Force Greaseable</i>	UJ270		U-Joint (Front)Ⓛ	UJ458
	<i>Brute Force Non Greaseable</i>	UJ254		(For Aluminum Drive Shaft)	UJ458C
	(For Aluminum Drive Shaft)	UJ354C		<i>Brute Force Non Greaseable</i>	UJ458BF
	U-Joint (Center)Ⓢ	UJ354		U-Joint (Rear)Ⓢ	UJ458
	<i>Brute Force Greaseable</i>	UJ270		(For Aluminum Drive Shaft)	UJ458C
	<i>Brute Force Non Greaseable</i>	UJ254		<i>Brute Force Non Greaseable</i>	UJ458BF
	(For Aluminum Drive Shaft)	UJ354C			(Continued)
	U-Joint (Rear)Ⓢ	UJ458			
	(For Aluminum Drive Shaft)	UJ458C			
	<i>Brute Force Non Greaseable</i>	UJ458BF			

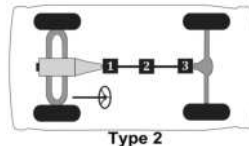
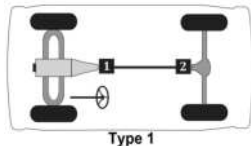

MFG./YEAR	MODEL & LOCATION	PART NO.	MFG./YEAR	MODEL & LOCATION	PART NO.
Drive Shaft (2 W/D) (Cont.)			Drive Shaft (2 W/D) (Cont.)		
U-Joint (Cont.)			U-Joint (Cont.)		
1997-1994 R1500 w/ 2 Joint Steel Driveshaft:			1993-1990 Dakota w/ 2 Joint Shaft & 2.625" Yoke:		
[Type 1]			[Type 1]		
U-Joint (Front)Ⓢ		UJ316	U-Joint (Front)Ⓢ		UJ316
Brute Force Greaseable		UJ248	Brute Force Greaseable		UJ248
Clamp Kit (Front)		UJ316-10	Clamp Kit (Front)		UJ316-10
U-Joint (Rear)Ⓢ		UJ316	U-Joint (Rear)Ⓢ		UJ316
Brute Force Greaseable		UJ248	Brute Force Greaseable		UJ248
Clamp Kit (Rear)		UJ316-10	Clamp Kit (Rear)		UJ316-10
1993-1992 D150 w/ 2 Joint Shaft & 2.125" Yoke:			1993-1990 Dakota w/ 3 Joint Shaft & 2.125" Yoke:		
[Type 1]			[Type 2]		
U-Joint (Front)Ⓢ		UJ317	U-Joint (Front)Ⓢ		UJ317
Brute Force Greaseable		UJ246	Brute Force Greaseable		UJ246
Clamp Kit (Front)		UJ318-10	Clamp Kit (Front)		UJ318-10
U-Joint (Rear)Ⓢ		UJ317	U-Joint (Center)Ⓢ		UJ317
Brute Force Greaseable		UJ246	Brute Force Greaseable		UJ246
Clamp Kit (Rear)		UJ318-10	Clamp Kit (Center)		UJ318-10
1993-1992 D150 w/ 2 Joint Shaft & 2.625" Yoke:			U-Joint (Rear)Ⓢ		
[Type 1]			[Type 2]		
U-Joint (Front)Ⓢ		UJ316	U-Joint (Front)Ⓢ		UJ316
Brute Force Greaseable		UJ248	Brute Force Greaseable		UJ248
Clamp Kit (Front)		UJ316-10	Clamp Kit (Front)		UJ316-10
U-Joint (Rear)Ⓢ		UJ316	U-Joint (Center)Ⓢ		UJ316
Brute Force Greaseable		UJ248	Brute Force Greaseable		UJ248
Clamp Kit (Rear)		UJ316-10	Clamp Kit (Center)		UJ316-10
1993-1992 D150 w/ 3 Joint Shaft & 2.125" Yoke:			U-Joint (Rear)Ⓢ		
[Type 2]			[Type 1]		
U-Joint (Front)Ⓢ		UJ317	U-Joint (Front)Ⓢ		UJ317
Brute Force Greaseable		UJ246	Brute Force Greaseable		UJ246
Clamp Kit (Front)		UJ318-10	Clamp Kit (Front)		UJ318-10
U-Joint (Center)Ⓢ		UJ317	U-Joint (Rear)Ⓢ		UJ317
Brute Force Greaseable		UJ246	Brute Force Greaseable		UJ246
Clamp Kit (Center)		UJ318-10	Clamp Kit (Rear)		UJ318-10
U-Joint (Rear)Ⓢ		UJ317	1993-1988 Ramcharger:		
Brute Force Greaseable		UJ246	[Type 1]		
Clamp Kit (Rear)		UJ318-10	U-Joint (Front)Ⓢ		UJ317
1993-1992 D150 w/ 3 Joint Shaft & 2.625" Yoke:			Brute Force Greaseable		UJ246
[Type 2]			Clamp Kit (Front)		UJ318-10
U-Joint (Front)Ⓢ		UJ316	U-Joint (Rear)Ⓢ		UJ317
Brute Force Greaseable		UJ248	Brute Force Greaseable		UJ246
Clamp Kit (Front)		UJ316-10	Clamp Kit (Rear)		UJ318-10
U-Joint (Center)Ⓢ		UJ316	1991-1988 D100 & D150 w/ 2 Joint Shaft:		
Brute Force Greaseable		UJ248	[Type 1]		
Clamp Kit (Center)		UJ316-10	U-Joint (Front)Ⓢ		UJ317
U-Joint (Rear)Ⓢ		UJ316	Brute Force Greaseable		UJ246
Brute Force Greaseable		UJ248	Clamp Kit (Front)		UJ318-10
Clamp Kit (Rear)		UJ316-10	U-Joint (Rear)Ⓢ		UJ317
1993-1990 Dakota w/ 2 Joint Shaft & 2.125" Yoke:			Brute Force Greaseable		UJ246
[Type 1]			Clamp Kit (Rear)		UJ318-10
U-Joint (Front)Ⓢ		UJ317	(Continued)		
Brute Force Greaseable		UJ246			
Clamp Kit (Front)		UJ318-10			
U-Joint (Rear)Ⓢ		UJ317			
Brute Force Greaseable		UJ246			
Clamp Kit (Rear)		UJ318-10			

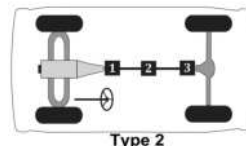
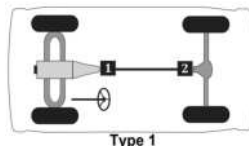

Passenger cars, light & medium trucks

Dodge Truck 1/2 ton -- (Cont.)

MFG./YEAR	MODEL & LOCATION	PART NO.	MFG./YEAR	MODEL & LOCATION	PART NO.
Drive Shaft (2 W/D) (Cont.)			Drive Shaft (2 W/D) (Cont.)		
U-Joint (Cont.)			U-Joint (Cont.)		
1991-1988 D100 & D150 w/ 3 Joint Shaft: [Type 2]			1981-1975 Ramcharger w/ 2.125" Yoke: [Type 1]		
	U-Joint (Front)Ⓚ	UJ317		U-Joint (Front)Ⓚ	UJ315G
	Brute Force Greaseable	UJ246		Brute Force Greaseable	UJ246
	Clamp Kit (Front)	UJ318-10		Clamp Kit (Front)	UJ318-10
	U-Joint (Center)Ⓛ	UJ317		U-Joint (Rear)Ⓛ	UJ315G
	Brute Force Greaseable	UJ246		Brute Force Greaseable	UJ246
	Clamp Kit (Center)	UJ318-10		Clamp Kit (Rear)	UJ318-10
	U-Joint (Rear)Ⓛ	UJ317		1981-1975 Ramcharger w/ 2.625" Yoke: [Type 1]	
	Brute Force Greaseable	UJ246		U-Joint (Front)Ⓚ	UJ316
	Clamp Kit (Rear)	UJ318-10		Brute Force Greaseable	UJ248
	1989-1987 Dakota w/ 2 Joint Shaft: [Type 1]			Clamp Kit (Front)	UJ316-10
	U-Joint (Front)Ⓚ	UJ317		U-Joint (Rear)Ⓛ	UJ316
	Brute Force Greaseable	UJ246		Brute Force Greaseable	UJ248
	Clamp Kit (Front)	UJ318-10		Clamp Kit (Rear)	UJ316-10
	U-Joint (Rear)Ⓛ	UJ317		1981-1970 D100 & D150 w/ 2 Joint Shaft & 2.125" Yoke: [Type 1]	
	Brute Force Greaseable	UJ246		U-Joint (Front)Ⓚ	UJ315G
	Clamp Kit (Rear)	UJ318-10		Brute Force Greaseable	UJ246
	1989-1987 Dakota w/ 3 Joint Shaft: [Type 2]			Clamp Kit (Front)	UJ318-10
	U-Joint (Front)Ⓚ	UJ317		U-Joint (Rear)Ⓛ	UJ315G
	Brute Force Greaseable	UJ246		Brute Force Greaseable	UJ246
	Clamp Kit (Front)	UJ318-10		Clamp Kit (Rear)	UJ318-10
	U-Joint (Center)Ⓛ	UJ317		1981-1970 D100 & D150 w/ 2 Joint Shaft & 2.625" Yoke: [Type 1]	
	Brute Force Greaseable	UJ246		U-Joint (Front)Ⓚ	UJ316
	Clamp Kit (Center)	UJ318-10		Brute Force Greaseable	UJ248
	U-Joint (Rear)Ⓛ	UJ317		Clamp Kit (Front)	UJ316-10
	Brute Force Greaseable	UJ246		U-Joint (Rear)Ⓛ	UJ316
	Clamp Kit (Rear)	UJ318-10		Brute Force Greaseable	UJ248
	1987-1982 Ramcharger: [Type 1]			Clamp Kit (Rear)	UJ316-10
	U-Joint (Front)Ⓚ	UJ315G		1981-1970 D100 & D150 w/ 3 Joint Shaft & 2.125" Yoke: [Type 2]	
	Brute Force Greaseable	UJ246		U-Joint (Front)Ⓚ	UJ315G
	Clamp Kit (Front)	UJ318-10		Brute Force Greaseable	UJ246
	U-Joint (Rear)Ⓛ	UJ315G		Clamp Kit (Front)	UJ318-10
	Brute Force Greaseable	UJ246		U-Joint (Center)Ⓛ	UJ315G
	Clamp Kit (Rear)	UJ318-10		Brute Force Greaseable	UJ246
	1987-1982 D100 & D150 w/ 2 Joint Shaft: [Type 1]			Clamp Kit (Center)	UJ318-10
	U-Joint (Front)Ⓚ	UJ315G		U-Joint (Rear)Ⓛ	UJ315G
	Brute Force Greaseable	UJ246		Brute Force Greaseable	UJ246
	Clamp Kit (Front)	UJ318-10		Clamp Kit (Rear)	UJ318-10
	U-Joint (Rear)Ⓛ	UJ315G		1981-1970 D100 & D150 w/ 3 Joint Shaft & 2.625" Yoke: [Type 2]	
	Brute Force Greaseable	UJ246		U-Joint (Front)Ⓚ	UJ316
	Clamp Kit (Rear)	UJ318-10		Brute Force Greaseable	UJ248
	1987-1982 D100 & D150 w/ 3 Joint Shaft: [Type 2]			Clamp Kit (Front)	UJ316-10
	U-Joint (Front)Ⓚ	UJ315G		U-Joint (Center)Ⓛ	UJ316
	Brute Force Greaseable	UJ246		Brute Force Greaseable	UJ248
	Clamp Kit (Front)	UJ318-10		Clamp Kit (Center)	UJ316-10
	U-Joint (Center)Ⓛ	UJ315G		U-Joint (Rear)Ⓛ	UJ316
	Brute Force Greaseable	UJ246		Brute Force Greaseable	UJ248
	Clamp Kit (Center)	UJ318-10		Clamp Kit (Rear)	UJ316-10
	U-Joint (Rear)Ⓛ	UJ315G			
	Brute Force Greaseable	UJ246			
	Clamp Kit (Rear)	UJ318-10			

(Continued)

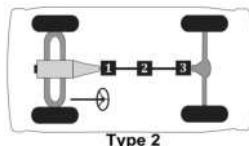
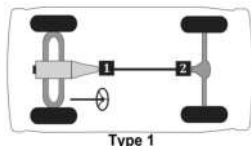

MFG./YEAR	MODEL & LOCATION	PART NO.	MFG./YEAR	MODEL & LOCATION	PART NO.
Drive Shaft (2 W/D) (Cont.)			Drive Shaft (4 W/D) (Cont.)		
U-Joint (Cont.)			U-Joint (Cont.)		
1969-1961 D100 w/ 2 Joint Shaft: [Type 1]			2009 R1500 w/ 3.7L Eng. Exc. Mega Cab:		
			[Type 15]		
	U-Joint (Front)❶	UJ315G		U-Joint (Fr. Shaft; Frt.)❶	UJ354
	Brute Force Greaseable	UJ246		Brute Force Greaseable	UJ270
	Clamp Kit (Front)	UJ318-10		Brute Force Non Greaseable	UJ254
	U-Joint (Rear)❷	UJ315G		(For Aluminum Drive Shaft)	UJ354C
	Brute Force Greaseable	UJ246		U-Joint (Rr. Shaft; Frt.)❸	UJ354
	Clamp Kit (Rear)	UJ318-10		Brute Force Greaseable	UJ270
1969-1961 D100 w/ 3 Joint Shaft: [Type 2]				Brute Force Non Greaseable	UJ254
	U-Joint (Front)❶	UJ315G		(For Aluminum Drive Shaft)	UJ354C
	Brute Force Greaseable	UJ246		U-Joint (Rr. Shaft; Rr.)❹	UJ354
	Clamp Kit (Front)	UJ318-10		Brute Force Greaseable	UJ270
	U-Joint (Center)❸	UJ315G		Brute Force Non Greaseable	UJ254
	Brute Force Greaseable	UJ246		(For Aluminum Drive Shaft)	UJ354C
	Clamp Kit (Center)	UJ318-10	2009 R1500 w/ 4.7L & 5.7L Eng. Exc. Mega Cab: [Type 15]		
	U-Joint (Rear)❹	UJ315G		U-Joint (Fr. Shaft; Frt.)❶	UJ354
	Brute Force Greaseable	UJ246		Brute Force Greaseable	UJ270
	Clamp Kit (Rear)	UJ318-10		Brute Force Non Greaseable	UJ254
Drive Shaft (4 W/D)				(For Aluminum Drive Shaft)	UJ354C
U-Joint				U-Joint (Rr. Shaft; Frt.)❸	UJ331
2010 R1500 w/ 2 Joint Shaft: [Type 17]				Brute Force Greaseable	UJ232
	U-Joint (Rr. Shaft; Frt.)❶	UJ331		Brute Force Non Greaseable	UJ231
	Brute Force Greaseable	UJ232		(For Aluminum Drive Shaft)	UJ331C
	Brute Force Non Greaseable	UJ231		U-Joint (Rr. Shaft; Rr.)❹	UJ331
	(For Aluminum Drive Shaft)	UJ331C		Brute Force Greaseable	UJ232
	U-Joint (Rr. Shaft; Rr.)❷	UJ331		Brute Force Non Greaseable	UJ231
	Brute Force Greaseable	UJ232		(For Aluminum Drive Shaft)	UJ331C
	Brute Force Non Greaseable	UJ231	2009 R1500 w/ Mega Cab: [Type 26]		
	(For Aluminum Drive Shaft)	UJ331C		U-Joint (Fr. Shaft; Frt.)❶	UJ534G
2010 R1500 w/ 3 Joint Shaft: [Type 18]				Brute Force Greaseable	UJ235
	U-Joint (Rr. Shaft; Frt.)❶	UJ354		Brute Force Non Greaseable	UJ234
	Brute Force Greaseable	UJ270		U-Joint (Fr. Shaft; Rr.)❷	[2] UJ331A
	Brute Force Non Greaseable	UJ254		Brute Force Greaseable	UJ232A
	(For Aluminum Drive Shaft)	UJ354C		U-Joint (Rr. Shaft; Frt.)❸	UJ330A
	U-Joint (Rr. Shaft; Ctr.)❸	UJ354		Brute Force Greaseable	UJ295A
	Brute Force Greaseable	UJ270		U-Joint (Rr. Shaft; Rr.)❹	UJ330A
	Brute Force Non Greaseable	UJ254		Brute Force Greaseable	UJ295A
	(For Aluminum Drive Shaft)	UJ354C		U-Joint (Wheel Joint)❹	[2] UJ464
	U-Joint (Rr. Shaft; Rr.)❹	UJ354		Centering Ball Kit	UJ617
	Brute Force Greaseable	UJ270	2009-2004 Durango: [Type 15]		
	Brute Force Non Greaseable	UJ254		U-Joint (Fr. Shaft; Frt.)❶	UJ369
	(For Aluminum Drive Shaft)	UJ354C		Brute Force Greaseable	UJ280
2010 R1500 w/ 3 Joint Shaft: [Type 18]				Brute Force Non Greaseable	UJ269
	U-Joint (Rr. Shaft; Frt.)❶	UJ354		(For Aluminum Drive Shaft)	UJ369C
	Brute Force Greaseable	UJ270		U-Joint (Rr. Shaft; Frt.)❷	UJ534G
	Brute Force Non Greaseable	UJ254		Brute Force Greaseable	UJ235
	(For Aluminum Drive Shaft)	UJ354C		Brute Force Non Greaseable	UJ234
	U-Joint (Rr. Shaft; Rr.)❸	UJ354		U-Joint (Rr. Shaft; Rr.)❸	UJ534G
	Brute Force Greaseable	UJ270		Brute Force Greaseable	UJ235
	Brute Force Non Greaseable	UJ254		Brute Force Non Greaseable	UJ234
	(For Aluminum Drive Shaft)	UJ354C		U-Joint (Rr. Shaft; Rr.)❹	UJ235
				Brute Force Greaseable	UJ235
				Brute Force Non Greaseable	UJ234

(Continued)

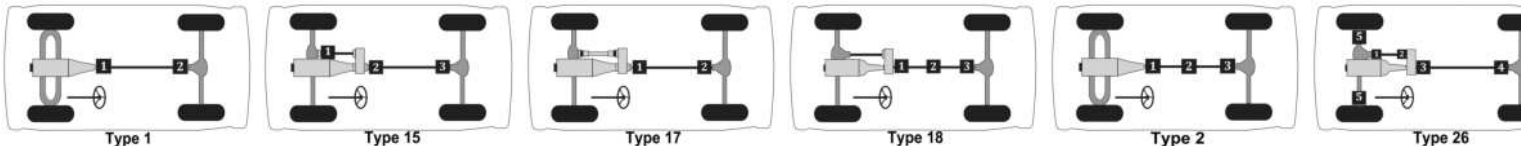

Passenger cars, light & medium trucks

Dodge Truck 1/2 ton -- (Cont.)

MFG./YEAR	MODEL & LOCATION	PART NO.	MFG./YEAR	MODEL & LOCATION	PART NO.
Drive Shaft (4 W/D) (Cont.)			Drive Shaft (4 W/D) (Cont.)		
U-Joint (Cont.)			U-Joint (Cont.)		
2009-2001 Dakota: [Type 15]			2008-2006 R1500 w/ Mega Cab: [Type 26]		
	U-Joint (Fr. Shaft; Frt.) [⊙]	UJ369		U-Joint (Fr. Shaft; Frt.) [⊙]	UJ534G
	Brute Force Greaseable	UJ280		Brute Force Greaseable	UJ235
	Brute Force Non Greaseable	UJ269		Brute Force Non Greaseable	UJ234
	(For Aluminum Drive Shaft)	UJ369C		U-Joint (Fr. Shaft; Rr.) [⊙]	[2] UJ331A
	U-Joint (Rr. Shaft; Frt.) [⊙]	UJ354		Brute Force Greaseable	UJ232A
	Brute Force Greaseable	UJ270		U-Joint (Rr. Shaft; Frt.) [⊙]	UJ330A
	Brute Force Non Greaseable	UJ254		Brute Force Greaseable	UJ295A
	(For Aluminum Drive Shaft)	UJ354C		U-Joint (Rr. Shaft; Rr.) [⊙]	UJ330A
	U-Joint (Rr. Shaft; Rr.) [⊙]	UJ354		Brute Force Greaseable	UJ295A
	Brute Force Greaseable	UJ270		U-Joint (Wheel Joint) [⊙]	[2] UJ464
	Brute Force Non Greaseable	UJ254		Centering Ball Kit	UJ617
	(For Aluminum Drive Shaft)	UJ354C		2005-2002 R1500 w/ 2 Joint Shaft: [Type 15]	
	2008-2006 R1500 w/ Quad Cab & Long Bed:			U-Joint (Fr. Shaft; Frt.) [⊙]	UJ354
	[Type 16]			Brute Force Greaseable	UJ270
	U-Joint (Fr. Shaft; Frt.) [⊙]	UJ354		Brute Force Non Greaseable	UJ254
	Brute Force Greaseable	UJ270		(For Aluminum Drive Shaft)	UJ354C
	Brute Force Non Greaseable	UJ254		U-Joint (Rr. Shaft; Frt.) [⊙]	UJ354
	(For Aluminum Drive Shaft)	UJ354C		Brute Force Greaseable	UJ270
	U-Joint (Rr. Shaft; Frt.) [⊙]	UJ354		Brute Force Non Greaseable	UJ254
	Brute Force Greaseable	UJ270		(For Aluminum Drive Shaft)	UJ354C
	Brute Force Non Greaseable	UJ254		U-Joint (Rr. Shaft; Rr.) [⊙]	UJ354
	(For Aluminum Drive Shaft)	UJ354C		Brute Force Greaseable	UJ270
	U-Joint (Rr. Shaft; Ctr.) [⊙]	UJ354		Brute Force Non Greaseable	UJ254
	Brute Force Greaseable	UJ270		(For Aluminum Drive Shaft)	UJ354C
	Brute Force Non Greaseable	UJ254		2005-2002 R1500 w/ 3 Joint Shaft: [Type 16]	
	(For Aluminum Drive Shaft)	UJ354C		U-Joint (Fr. Shaft; Frt.) [⊙]	UJ354
	U-Joint (Rr. Shaft; Rr.) [⊙]	UJ354		Brute Force Greaseable	UJ270
	Brute Force Greaseable	UJ270		Brute Force Non Greaseable	UJ254
	Brute Force Non Greaseable	UJ254		(For Aluminum Drive Shaft)	UJ354C
	(For Aluminum Drive Shaft)	UJ354C		U-Joint (Rr. Shaft; Frt.) [⊙]	UJ354
	U-Joint (Rr. Shaft; Rr.) [⊙]	UJ354		Brute Force Greaseable	UJ270
	Brute Force Greaseable	UJ270		Brute Force Non Greaseable	UJ254
	Brute Force Non Greaseable	UJ254		(For Aluminum Drive Shaft)	UJ354C
	(For Aluminum Drive Shaft)	UJ354C		U-Joint (Rr. Shaft; Ctr.) [⊙]	UJ354
	U-Joint (Fr. Shaft; Frt.) [⊙]	UJ354		Brute Force Greaseable	UJ270
	Brute Force Greaseable	UJ270		Brute Force Non Greaseable	UJ254
	Brute Force Non Greaseable	UJ254		(For Aluminum Drive Shaft)	UJ354C
	(For Aluminum Drive Shaft)	UJ354C		U-Joint (Rr. Shaft; Rr.) [⊙]	UJ354
	U-Joint (Rr. Shaft; Frt.) [⊙]	UJ354		Brute Force Greaseable	UJ270
	Brute Force Greaseable	UJ270		Brute Force Non Greaseable	UJ254
	Brute Force Non Greaseable	UJ254		(For Aluminum Drive Shaft)	UJ354C
	(For Aluminum Drive Shaft)	UJ354C		U-Joint (Rr. Shaft; Rr.) [⊙]	UJ354
	U-Joint (Rr. Shaft; Rr.) [⊙]	UJ354		Brute Force Greaseable	UJ270
	Brute Force Greaseable	UJ270		Brute Force Non Greaseable	UJ254
	Brute Force Non Greaseable	UJ254		(For Aluminum Drive Shaft)	UJ354C
	(For Aluminum Drive Shaft)	UJ354C			(Continued)

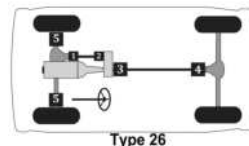
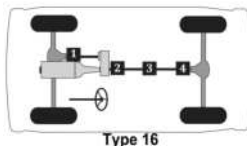
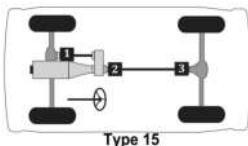

230 ▲ For Use w/ 1.063" Bearing Cap Application. ⊙ For Use w/ 1.188" Bearing Cap Application. ◇ For Use w/ Inner Lock Ring Application on Half Shaft. □ For Use w/ Outer Lock Ring Application on Half Shaft.

MFG./YEAR	MODEL & LOCATION	PART NO.	MFG./YEAR	MODEL & LOCATION	PART NO.
Drive Shaft (4 W/D) (Cont.)			Drive Shaft (4 W/D) (Cont.)		
U-Joint (Cont.)			U-Joint (Cont.)		
2003-2001 Durango: [Type 15]			2001-2000 R1500 w/ 3 Joint Shaft: [Type 27]		
	U-Joint (Frnt. Shaft; Frt.) ^①	UJ369		U-Joint (Frnt. Shaft; Frt.) ^①	UJ354
	Brute Force Greaseable	UJ280		Brute Force Greaseable	UJ270
	Brute Force Non Greaseable	UJ269		Brute Force Non Greaseable	UJ254
	(For Aluminum Drive Shaft)	UJ369C		(For Aluminum Drive Shaft)	UJ354C
	U-Joint (Rr. Shaft; Frt.) ^②	UJ354		Clamp Kit (Frnt. Shaft; Frt.)	UJ437-10
	Brute Force Greaseable	UJ270		U-Joint (Frnt. Shaft; Rr.) ^②	[2] UJ354
	Brute Force Non Greaseable	UJ254		Brute Force Greaseable	UJ270
	(For Aluminum Drive Shaft)	UJ354C		Brute Force Non Greaseable	UJ254
	U-Joint (Rr. Shaft; Rr.) ^③	UJ354		(For Aluminum Drive Shaft)	UJ354C
	Brute Force Greaseable	UJ270		U-Joint (Rr. Shaft; Frt.) ^③	UJ354
	Brute Force Non Greaseable	UJ254		Brute Force Greaseable	UJ270
	(For Aluminum Drive Shaft)	UJ354C		Brute Force Non Greaseable	UJ254
	2001-2000 R1500 w/ 2 Joint Shaft: [Type 26]			(For Aluminum Drive Shaft)	UJ354C
	U-Joint (Frnt. Shaft; Frt.) ^①	UJ354		U-Joint (Rr. Shaft; Ctr.) ^④	UJ354
	Brute Force Greaseable	UJ270		Brute Force Greaseable	UJ270
	Brute Force Non Greaseable	UJ254		Brute Force Non Greaseable	UJ254
	(For Aluminum Drive Shaft)	UJ354C		(For Aluminum Drive Shaft)	UJ354C
	Clamp Kit (Frnt. Shaft; Frt.)	UJ437-10		U-Joint (Rr. Shaft; Rr.) ^⑤	UJ354
	U-Joint (Frnt. Shaft; Rr.) ^②	[2] UJ354		Brute Force Greaseable	UJ270
	Brute Force Greaseable	UJ270		Brute Force Non Greaseable	UJ254
	Brute Force Non Greaseable	UJ254		(For Aluminum Drive Shaft)	UJ354C
	(For Aluminum Drive Shaft)	UJ354C		U-Joint (Wheel Joint) ^⑥	[2] UJ371
	U-Joint (Rr. Shaft; Frt.) ^③	UJ354		Brute Force Greaseable	UJ377
	Brute Force Greaseable	UJ270		Brute Force Non Greaseable	UJ371
	Brute Force Non Greaseable	UJ254		Centering Ball Kit	UJ617
	(For Aluminum Drive Shaft)	UJ354C		Flange Yoke	UJ628C
	U-Joint (Rr. Shaft; Rr.) ^④	UJ354		H Yoke	UJ648
	Brute Force Greaseable	UJ270			
	Brute Force Non Greaseable	UJ254		2000 Dakota: [Type 13]	
	(For Aluminum Drive Shaft)	UJ354C		U-Joint (Frnt. Shaft; Frt.) ^①	UJ369
	U-Joint (Wheel Joint) ^⑥	[2] UJ371		Brute Force Greaseable	UJ280
	Brute Force Greaseable	UJ377		Brute Force Non Greaseable	UJ269
	Brute Force Non Greaseable	UJ371		(For Aluminum Drive Shaft)	UJ369C
	Centering Ball Kit	UJ617		Clamp Kit (Frnt. Shaft; Frt.)	UJ437-10
	Flange Yoke	UJ628C		U-Joint (Frnt. Shaft; Rr.) ^②	[2] UJ380
	H Yoke	UJ648		Brute Force Greaseable	UJ280
				Brute Force Non Greaseable	UJ269
				U-Joint (Rr. Shaft; Frt.) ^③	UJ354
				Brute Force Greaseable	UJ270
				Brute Force Non Greaseable	UJ254
				(For Aluminum Drive Shaft)	UJ354C
				U-Joint (Rr. Shaft; Rr.) ^④	UJ354
				Brute Force Greaseable	UJ270
				Brute Force Non Greaseable	UJ254
				(For Aluminum Drive Shaft)	UJ354C
				Centering Ball Kit	UJ617
				H Yoke	UJ647

(Continued)

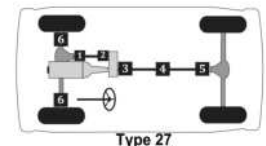
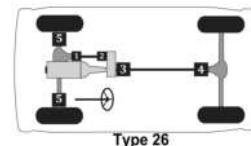
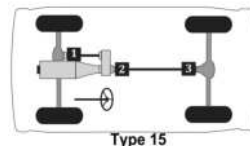
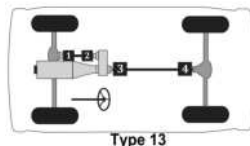

Passenger cars, light & medium trucks

Dodge Truck 1/2 ton -- (Cont.)

MFG./YEAR	MODEL & LOCATION	PART NO.	MFG./YEAR	MODEL & LOCATION	PART NO.
Drive Shaft (4 W/D) (Cont.)			Drive Shaft (4 W/D) (Cont.)		
U-Joint (Cont.)			U-Joint (Cont.)		
2000 Durango: [Type 13]			1999 Durango: [Type 13]		
	U-Joint (Fr. Shaft; Frt.) [⊙]	UJ369		U-Joint (Fr. Shaft; Frt.) [⊙]	UJ369
	Brute Force Greaseable	UJ280		Brute Force Greaseable	UJ280
	Brute Force Non Greaseable	UJ269		Brute Force Non Greaseable	UJ269
	(For Aluminum Drive Shaft)	UJ369C		(For Aluminum Drive Shaft)	UJ369C
	Clamp Kit (Fr. Shaft; Frt.)	UJ437-10		Clamp Kit (Fr. Shaft; Frt.)	UJ437-10
	U-Joint (Fr. Shaft; Rr.) [⊙]	[2] UJ380		U-Joint (Fr. Shaft; Rr.) [⊙]	[2] UJ380
	Brute Force Greaseable	UJ280		Brute Force Greaseable	UJ280
	Brute Force Non Greaseable	UJ269		Brute Force Non Greaseable	UJ269
	U-Joint (Rr. Shaft; Frt.) [⊙]	UJ354		U-Joint (Rr. Shaft; Frt.) [⊙]	UJ354
	Brute Force Greaseable	UJ270		Brute Force Greaseable	UJ270
	Brute Force Non Greaseable	UJ254		Brute Force Non Greaseable	UJ254
	(For Aluminum Drive Shaft)	UJ354C		(For Aluminum Drive Shaft)	UJ354C
	U-Joint (Rr. Shaft; Rr.) [⊙]	UJ354		U-Joint (Rr. Shaft; Rr.) [⊙]	UJ458
	Brute Force Greaseable	UJ270		(For Aluminum Drive Shaft)	UJ458C
	Brute Force Non Greaseable	UJ254		Brute Force Non Greaseable	UJ458BF
	(For Aluminum Drive Shaft)	UJ354C		Centering Ball Kit	UJ617
	Centering Ball Kit	UJ617		H Yoke	UJ647
	H Yoke	UJ647			
1999 Dakota: [Type 13]			1999 R1500 w/ 2 Joint Shaft: [Type 26]		
	U-Joint (Fr. Shaft; Frt.) [⊙]	UJ369		U-Joint (Fr. Shaft; Frt.) [⊙]	UJ458
	Brute Force Greaseable	UJ280		(For Aluminum Drive Shaft)	UJ458C
	Brute Force Non Greaseable	UJ269		Brute Force Non Greaseable	UJ458BF
	(For Aluminum Drive Shaft)	UJ369C		U-Joint (Fr. Shaft; Rr.) [⊙]	[2] UJ354
	Clamp Kit (Fr. Shaft; Frt.)	UJ437-10		Brute Force Greaseable	UJ270
	U-Joint (Fr. Shaft; Rr.) [⊙]	[2] UJ380		Brute Force Non Greaseable	UJ254
	Brute Force Greaseable	UJ280		(For Aluminum Drive Shaft)	UJ354C
	Brute Force Non Greaseable	UJ269		U-Joint (Rr. Shaft; Frt.) [⊙]	UJ354
	U-Joint (Rr. Shaft; Frt.) [⊙]	UJ354		Brute Force Greaseable	UJ270
	Brute Force Greaseable	UJ270		Brute Force Non Greaseable	UJ254
	Brute Force Non Greaseable	UJ254		(For Aluminum Drive Shaft)	UJ354C
	(For Aluminum Drive Shaft)	UJ354C		U-Joint (Rr. Shaft; Rr.) [⊙]	UJ458
	U-Joint (Rr. Shaft; Rr.) [⊙]	UJ458		(For Aluminum Drive Shaft)	UJ458C
	(For Aluminum Drive Shaft)	UJ458C		Brute Force Non Greaseable	UJ458BF
	Brute Force Non Greaseable	UJ458BF		U-Joint (Wheel Joint) [⊙]	[2] UJ371
	Centering Ball Kit	UJ617		Brute Force Greaseable	UJ377
	H Yoke	UJ647		Brute Force Non Greaseable	UJ371
				Centering Ball Kit	UJ617
				Flange Yoke	UJ628C
				H Yoke	UJ648
					(Continued)

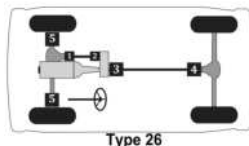
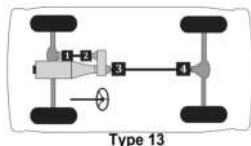

232 ▲ For Use w/ 1.063" Bearing Cap Application. ⊙ For Use w/ 1.188" Bearing Cap Application. ◇ For Use w/ Inner Lock Ring Application on Half Shaft. □ For Use w/ Outer Lock Ring Application on Half Shaft.

MFG./YEAR	MODEL & LOCATION	PART NO.	MFG./YEAR	MODEL & LOCATION	PART NO.
Drive Shaft (4 W/D) (Cont.)			Drive Shaft (4 W/D) (Cont.)		
U-Joint (Cont.)			U-Joint (Cont.)		
1999	R1500 w/ 3 Joint Shaft: [Type 27]		1998	R1500 w/ 2 Joint Rr. Shaft & 1.063" Dia. Brg. Caps in Slip Yoke: [Type 26]	
	U-Joint (Frnt. Shaft; Frnt.) ①	UJ458		U-Joint (Frnt. Shaft; Frnt.) ①	UJ316
	(For Aluminum Drive Shaft)	UJ458C		Brute Force Greaseable	UJ248
	Brute Force Non Greaseable	UJ458BF		U-Joint (Frnt. Shaft; Rr.) ②	[2] UJ354
	U-Joint (Frnt. Shaft; Rr.) ②	[2] UJ354		Brute Force Greaseable	UJ270
	Brute Force Greaseable	UJ270		Brute Force Non Greaseable	UJ254
	Brute Force Non Greaseable	UJ254		(For Aluminum Drive Shaft)	UJ354C
	(For Aluminum Drive Shaft)	UJ354C		U-Joint (Rr. Shaft; Frnt.) ③	UJ316
	U-Joint (Rr. Shaft; Frnt.) ③	UJ354		Brute Force Greaseable	UJ248
	Brute Force Greaseable	UJ270		U-Joint (Rr. Shaft; Rr.) ④	UJ316
	Brute Force Non Greaseable	UJ254		Brute Force Greaseable	UJ248
	(For Aluminum Drive Shaft)	UJ354C		Clamp Kit (Rr. Shaft; Rr.)	UJ316-10
	U-Joint (Rr. Shaft; Rr.) ④	UJ354		U-Joint (Wheel Joint) ⑤	[2] UJ371
	Brute Force Greaseable	UJ270		Brute Force Greaseable	UJ377
	Brute Force Non Greaseable	UJ254		Brute Force Non Greaseable	UJ371
	(For Aluminum Drive Shaft)	UJ354C		Centering Ball Kit	UJ617
	U-Joint (Wheel Joint) ⑤	[2] UJ371		Flange Yoke	UJ628C
	Brute Force Greaseable	UJ377		H Yoke	UJ648
	Brute Force Non Greaseable	UJ371		1998 R1500 w/ 2 Joint Rr. Shaft & 1.125" Dia. Brg. Caps in Slip Yoke: [Type 26]	
	Centering Ball Kit	UJ617		U-Joint (Frnt. Shaft; Frnt.) ①	UJ458
	Flange Yoke	UJ628C		(For Aluminum Drive Shaft)	UJ458C
	H Yoke	UJ648		Brute Force Non Greaseable	UJ458BF
1998	Durango: [Type 13]			U-Joint (Frnt. Shaft; Rr.) ②	[2] UJ354
	U-Joint (Frnt. Shaft; Frnt.) ①	UJ369		Brute Force Greaseable	UJ270
	Brute Force Greaseable	UJ280		Brute Force Non Greaseable	UJ254
	Brute Force Non Greaseable	UJ269		(For Aluminum Drive Shaft)	UJ354C
	(For Aluminum Drive Shaft)	UJ369C		U-Joint (Rr. Shaft; Frnt.) ③	UJ316
	Clamp Kit (Frnt. Shaft; Frnt.)	UJ437-10		Brute Force Greaseable	UJ248
	U-Joint (Frnt. Shaft; Rr.) ②	[2] UJ380		U-Joint (Rr. Shaft; Rr.) ④	UJ316
	Brute Force Greaseable	UJ280		Brute Force Greaseable	UJ248
	Brute Force Non Greaseable	UJ269		Clamp Kit (Rr. Shaft; Rr.)	UJ316-10
	U-Joint (Rr. Shaft; Frnt.) ③	UJ316		U-Joint (Wheel Joint) ⑤	[2] UJ371
	Brute Force Greaseable	UJ248		Brute Force Greaseable	UJ377
	Clamp Kit (Rr. Shaft; Frnt.)	UJ316-10		Brute Force Non Greaseable	UJ371
	U-Joint (Rr. Shaft; Rr.) ④	UJ316		Centering Ball Kit	UJ617
	Brute Force Greaseable	UJ248		Flange Yoke	UJ628C
	Clamp Kit (Rr. Shaft; Rr.)	UJ316-10		H Yoke	UJ648
	Centering Ball Kit	UJ617			
	H Yoke	UJ648			

(Continued)

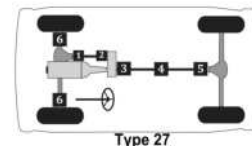
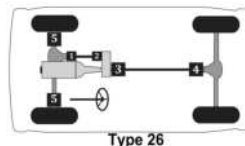
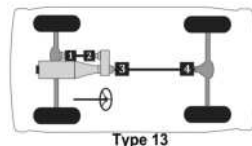

Passenger cars, light & medium trucks

Dodge Truck 1/2 ton -- (Cont.)

MFG./YEAR	MODEL & LOCATION	PART NO.	MFG./YEAR	MODEL & LOCATION	PART NO.
-----------	------------------	----------	-----------	------------------	----------

Drive Shaft (4 W/D) (Cont.)

U-Joint (Cont.)

1998	R1500 w/ 3 Joint Rr. Shaft & 1.063"	
	Dia. Brg. Caps in Slip Yoke: [Type 27]	
U-Joint (Fr. Shaft; Frt.) ⊙		UJ316
<i>Brute Force Greaseable</i>		UJ248
U-Joint (Fr. Shaft; Rr.) ⊙	[2]	UJ354
<i>Brute Force Greaseable</i>		UJ270
<i>Brute Force Non Greaseable</i>		UJ254
(For Aluminum Drive Shaft)		UJ354C
U-Joint (Rr. Shaft; Frt.) ⊙		UJ316
<i>Brute Force Greaseable</i>		UJ248
Clamp Kit (Rr. Shaft; Frt.)		UJ316-10
U-Joint (Rr. Shaft; Ctr.) ⊙		UJ316
<i>Brute Force Greaseable</i>		UJ248
Clamp Kit (Rr. Shaft; Ctr.)		UJ316-10
U-Joint (Rr. Shaft; Rr.) ⊙		UJ316
<i>Brute Force Greaseable</i>		UJ248
Clamp Kit (Rr. Shaft; Rr.)		UJ316-10
U-Joint (Wheel Joint) ⊙	[2]	UJ371
<i>Brute Force Greaseable</i>		UJ377
<i>Brute Force Non Greaseable</i>		UJ371
Centering Ball Kit		UJ617
Flange Yoke		UJ628C
H Yoke		UJ648

1998	R1500 w/ 3 Joint Rr. Shaft & 1.125"	
	Dia. Brg. Caps in Slip Yoke: [Type 27]	
U-Joint (Fr. Shaft; Frt.) ⊙		UJ458
(For Aluminum Drive Shaft)		UJ458C
<i>Brute Force Non Greaseable</i>		UJ458BF
U-Joint (Fr. Shaft; Rr.) ⊙	[2]	UJ354
<i>Brute Force Greaseable</i>		UJ270
<i>Brute Force Non Greaseable</i>		UJ254
(For Aluminum Drive Shaft)		UJ354C
U-Joint (Rr. Shaft; Frt.) ⊙		UJ316
<i>Brute Force Greaseable</i>		UJ248
Clamp Kit (Rr. Shaft; Frt.)		UJ316-10
U-Joint (Rr. Shaft; Ctr.) ⊙		UJ316
<i>Brute Force Greaseable</i>		UJ248
Clamp Kit (Rr. Shaft; Ctr.)		UJ316-10
U-Joint (Rr. Shaft; Rr.) ⊙		UJ316
<i>Brute Force Greaseable</i>		UJ248
Clamp Kit (Rr. Shaft; Rr.)		UJ316-10
U-Joint (Wheel Joint) ⊙	[2]	UJ371
<i>Brute Force Greaseable</i>		UJ377
<i>Brute Force Non Greaseable</i>		UJ371
Centering Ball Kit		UJ617
Flange Yoke		UJ628C
H Yoke		UJ648

Drive Shaft (4 W/D) (Cont.)

U-Joint (Cont.)

1998-1997 Dakota: [Type 13]	
U-Joint (Fr. Shaft; Frt.) ⊙	UJ369
<i>Brute Force Greaseable</i>	UJ280
<i>Brute Force Non Greaseable</i>	UJ269
(For Aluminum Drive Shaft)	UJ369C
Clamp Kit (Fr. Shaft; Frt.)	UJ437-10
U-Joint (Fr. Shaft; Rr.) ⊙	[2] UJ380
<i>Brute Force Greaseable</i>	UJ280
<i>Brute Force Non Greaseable</i>	UJ269
U-Joint (Rr. Shaft; Frt.) ⊙	UJ316
<i>Brute Force Greaseable</i>	UJ248
Clamp Kit (Rr. Shaft; Frt.)	UJ316-10
U-Joint (Rr. Shaft; Rr.) ⊙	UJ316
<i>Brute Force Greaseable</i>	UJ248
Clamp Kit (Rr. Shaft; Rr.)	UJ316-10
Centering Ball Kit	UJ617
H Yoke	UJ647
1997-1994 R1500 w/ 2 Joint Shaft: [Type 26]	
U-Joint (Fr. Shaft; Frt.) ⊙	UJ316
<i>Brute Force Greaseable</i>	UJ248
U-Joint (Fr. Shaft; Rr.) ⊙	[2] UJ354
<i>Brute Force Greaseable</i>	UJ270
<i>Brute Force Non Greaseable</i>	UJ254
(For Aluminum Drive Shaft)	UJ354C
U-Joint (Rr. Shaft; Frt.) ⊙	UJ316
<i>Brute Force Greaseable</i>	UJ248
Clamp Kit (Rr. Shaft; Frt.)	UJ316-10
U-Joint (Rr. Shaft; Rr.) ⊙	UJ316
<i>Brute Force Greaseable</i>	UJ248
Clamp Kit (Rr. Shaft; Rr.)	UJ316-10
U-Joint (Wheel Joint) ⊙	[2] UJ371
<i>Brute Force Greaseable</i>	UJ377
<i>Brute Force Non Greaseable</i>	UJ371
Centering Ball Kit	UJ617
Flange Yoke	UJ628C
H Yoke	UJ648

(Continued)

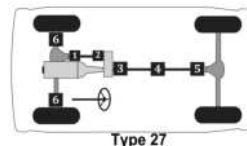
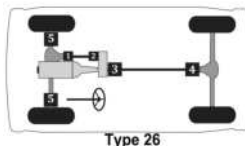
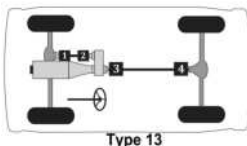

MFG./YEAR	MODEL & LOCATION	PART NO.	MFG./YEAR	MODEL & LOCATION	PART NO.
Drive Shaft (4 W/D) (Cont.)			Drive Shaft (4 W/D) (Cont.)		
U-Joint (Cont.)			U-Joint (Cont.)		
1997-1994 R1500 w/ 3 Joint Shaft: [Type 27]			1993-1992 W100 w/ 2 Joint Rr. Shaft & 2.125"		
			Yokes: [Type 26]		
U-Joint (Frnt. Shaft; Frt.) ①		UJ316	U-Joint (Frnt. Shaft; Frt.) ①		UJ317
Brute Force Greaseable		UJ248	Brute Force Greaseable		UJ246
U-Joint (Frnt. Shaft; Rr.) ②	[2]	UJ354	Clamp Kit (Frnt. Shaft; Frt.)		UJ318-10
Brute Force Greaseable		UJ270	U-Joint (Frnt. Shaft; Rr.) ②	[2]	UJ534G
Brute Force Non Greaseable		UJ254	Brute Force Greaseable		UJ235
(For Aluminum Drive Shaft)		UJ354C	Brute Force Non Greaseable		UJ234
U-Joint (Rr. Shaft; Frt.) ③		UJ316	U-Joint (Rr. Shaft; Frt.) ③		UJ317
Brute Force Greaseable		UJ248	Brute Force Greaseable		UJ246
U-Joint (Rr. Shaft; Ctr.) ④		UJ316	Clamp Kit (Rr. Shaft; Frt.)		UJ318-10
Brute Force Greaseable		UJ248	U-Joint (Rr. Shaft; Rr.) ④		UJ317
U-Joint (Rr. Shaft; Rr.) ⑤		UJ316	Brute Force Greaseable		UJ246
Brute Force Greaseable		UJ248	Clamp Kit (Rr. Shaft; Rr.)		UJ318-10
U-Joint (Wheel Joint) ⑥	[2]	UJ371	U-Joint (Wheel Joint) ⑥	[2]	UJ371
Brute Force Greaseable		UJ377	Brute Force Greaseable		UJ377
Brute Force Non Greaseable		UJ371	Brute Force Non Greaseable		UJ371
Centering Ball Kit		UJ617	Ball Seat Repair Kit		UJ606
Flange Yoke		UJ628C	Flange Yoke		UJ626
H Yoke		UJ648	H Yoke		UJ646
1996-1994 Dakota: [Type 13]			1993-1992 W100 w/ 2 Joint Rr. Shaft & 2.625"		
			Yokes: [Type 26]		
U-Joint (Frnt. Shaft; Frt.) ①		UJ319	U-Joint (Frnt. Shaft; Frt.) ①		UJ317
Clamp Kit (Frnt. Shaft; Frt.)		UJ318-10	Brute Force Greaseable		UJ246
U-Joint (Frnt. Shaft; Rr.) ②	[2]	UJ379	Clamp Kit (Frnt. Shaft; Frt.)		UJ318-10
Brute Force Greaseable		UJ280	U-Joint (Frnt. Shaft; Rr.) ②	[2]	UJ534G
Brute Force Non Greaseable		UJ269	Brute Force Greaseable		UJ235
U-Joint (Rr. Shaft; Frt.) ③		UJ316	Brute Force Non Greaseable		UJ234
Brute Force Greaseable		UJ248	U-Joint (Rr. Shaft; Frt.) ③		UJ316
Clamp Kit (Rr. Shaft; Frt.)		UJ316-10	Brute Force Greaseable		UJ248
U-Joint (Rr. Shaft; Rr.) ④		UJ316	Clamp Kit (Rr. Shaft; Frt.)		UJ316-10
Brute Force Greaseable		UJ248	U-Joint (Rr. Shaft; Rr.) ④		UJ316
Clamp Kit (Rr. Shaft; Rr.)		UJ316-10	Brute Force Greaseable		UJ248
Centering Ball Kit		UJ617	Clamp Kit (Rr. Shaft; Rr.)		UJ316-10
H Yoke		UJ647	U-Joint (Wheel Joint) ⑥	[2]	UJ371
			Brute Force Greaseable		UJ377
			Brute Force Non Greaseable		UJ371
			Ball Seat Repair Kit		UJ606
			Flange Yoke		UJ626
			H Yoke		UJ646

(Continued)

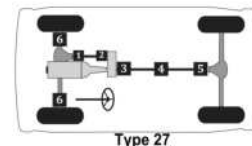
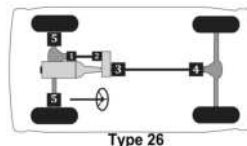
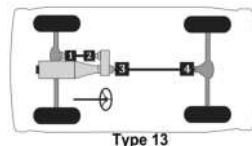

Passenger cars, light & medium trucks

Dodge Truck 1/2 ton -- (Cont.)

MFG./YEAR	MODEL & LOCATION	PART NO.	MFG./YEAR	MODEL & LOCATION	PART NO.
-----------	------------------	----------	-----------	------------------	----------

Drive Shaft (4 W/D) (Cont.)

U-Joint (Cont.)

1993-1992 W100 w/ 3 Joint Rr. Shaft: [Type 27]	
U-Joint (Frnt. Shaft; Frt.) [ⓐ]	UJ317
Brute Force Greaseable	UJ246
Clamp Kit (Frnt. Shaft; Frt.)	UJ318-10
U-Joint (Frnt. Shaft; Rr.) [ⓑ]	[2] UJ534G
Brute Force Greaseable	UJ235
Brute Force Non Greaseable	UJ234
U-Joint (Rr. Shaft; Frt.) [ⓐ]	UJ317
Brute Force Greaseable	UJ246
Clamp Kit (Rr. Shaft; Frt.)	UJ318-10
U-Joint (Rr. Shaft; Ctr.) [ⓐ]	UJ317
Brute Force Greaseable	UJ246
Clamp Kit (Rr. Shaft; Ctr.)	UJ318-10
U-Joint (Rr. Shaft; Rr.) [ⓐ]	UJ317
Brute Force Greaseable	UJ246
Clamp Kit (Rr. Shaft; Rr.)	UJ318-10
U-Joint (Wheel Joint) [ⓐ]	[2] UJ371
Brute Force Greaseable	UJ377
Brute Force Non Greaseable	UJ371
Ball Seat Repair Kit	UJ606
Flange Yoke	UJ626
H Yoke	UJ646

1993-1991 Dakota w/ Ext. Cab & 2.625" Rr. Shaft Yokes Exc. Alum.-Graphite Rr. Shaft:

[Type 13]

U-Joint (Frnt. Shaft; Frt.) [ⓐ]	UJ319
Clamp Kit (Frnt. Shaft; Frt.)	UJ318-10
U-Joint (Frnt. Shaft; Rr.) [ⓑ]	[2] UJ379
Brute Force Greaseable	UJ280
Brute Force Non Greaseable	UJ269
U-Joint (Rr. Shaft; Frt.) [ⓐ]	UJ316
Brute Force Greaseable	UJ248
Clamp Kit (Rr. Shaft; Frt.)	UJ316-10
U-Joint (Rr. Shaft; Rr.) [ⓐ]	UJ316
Brute Force Greaseable	UJ248
Clamp Kit (Rr. Shaft; Rr.)	UJ316-10
Centering Ball Kit	UJ617
H Yoke	UJ647

1993-1991 Dakota w/ Reg. Cab & 2.125" Rr. Shaft Yokes: [Type 13]

U-Joint (Frnt. Shaft; Frt.) [ⓐ]	UJ319
Clamp Kit (Frnt. Shaft; Frt.)	UJ318-10
U-Joint (Frnt. Shaft; Rr.) [ⓑ]	[2] UJ379
Brute Force Greaseable	UJ280
Brute Force Non Greaseable	UJ269
U-Joint (Rr. Shaft; Frt.) [ⓐ]	UJ317
Brute Force Greaseable	UJ246
Clamp Kit (Rr. Shaft; Frt.)	UJ318-10
U-Joint (Rr. Shaft; Rr.) [ⓐ]	UJ317
Brute Force Greaseable	UJ246
Clamp Kit (Rr. Shaft; Rr.)	UJ318-10
Centering Ball Kit	UJ617
H Yoke	UJ647

Drive Shaft (4 W/D) (Cont.)

U-Joint (Cont.)

1993-1991 Dakota w/ Reg. Cab & 2.625" Rr. Shaft Yokes: [Type 13]	
U-Joint (Frnt. Shaft; Frt.) [ⓐ]	UJ319
Clamp Kit (Frnt. Shaft; Frt.)	UJ318-10
U-Joint (Frnt. Shaft; Rr.) [ⓑ]	[2] UJ379
Brute Force Greaseable	UJ280
Brute Force Non Greaseable	UJ269
U-Joint (Rr. Shaft; Frt.) [ⓐ]	UJ316
Brute Force Greaseable	UJ248
Clamp Kit (Rr. Shaft; Frt.)	UJ316-10
U-Joint (Rr. Shaft; Rr.) [ⓐ]	UJ316
Brute Force Greaseable	UJ248
Clamp Kit (Rr. Shaft; Rr.)	UJ316-10
Centering Ball Kit	UJ617
H Yoke	UJ647

1993-1991 Dakota w/ Ext. Cab & 2.125" Rr. Shaft Yokes Exc. Alum.-Graphite Rr. Shaft:

[Type 13]

U-Joint (Frnt. Shaft; Frt.) [ⓐ]	UJ319
Clamp Kit (Frnt. Shaft; Frt.)	UJ318-10
U-Joint (Frnt. Shaft; Rr.) [ⓑ]	[2] UJ379
Brute Force Greaseable	UJ280
Brute Force Non Greaseable	UJ269
U-Joint (Rr. Shaft; Frt.) [ⓐ]	UJ317
Brute Force Greaseable	UJ246
Clamp Kit (Rr. Shaft; Frt.)	UJ318-10
U-Joint (Rr. Shaft; Rr.) [ⓐ]	UJ317
Brute Force Greaseable	UJ246
Clamp Kit (Rr. Shaft; Rr.)	UJ318-10
Centering Ball Kit	UJ617
H Yoke	UJ647

1993-1991 Dakota w/ Ext. Cab, Alum.-Graphite Rr. Shaft & 2.125" Rr. Shaft Yokes:

[Type 13]

U-Joint (Frnt. Shaft; Frt.) [ⓐ]	UJ319
Clamp Kit (Frnt. Shaft; Frt.)	UJ318-10
U-Joint (Frnt. Shaft; Rr.) [ⓑ]	[2] UJ379
Brute Force Greaseable	UJ280
Brute Force Non Greaseable	UJ269
U-Joint (Rr. Shaft; Frt.) [ⓐ]	UJ457
(For Aluminum Drive Shaft)	UJ457C
Clamp Kit (Rr. Shaft; Frt.)	UJ318-10
U-Joint (Rr. Shaft; Rr.) [ⓐ]	UJ457
(For Aluminum Drive Shaft)	UJ457C
Clamp Kit (Rr. Shaft; Rr.)	UJ318-10
Centering Ball Kit	UJ617
H Yoke	UJ647

(Continued)

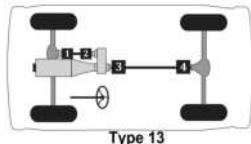

Type 13

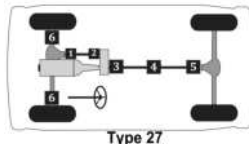

Type 27

MFG./YEAR	MODEL & LOCATION	PART NO.	MFG./YEAR	MODEL & LOCATION	PART NO.
Drive Shaft (4 W/D) (Cont.)			Drive Shaft (4 W/D) (Cont.)		
U-Joint (Cont.)			U-Joint (Cont.)		
1993-1991 Dakota w/ Ext. Cab, Alum.-Graphite			1993-1988 Ramcharger w/ 2.625" Yoke: [Type		
Rr. Shaft & 2.625" Rr. Shaft Yokes:			26]		
[Type 13]			U-Joint (Frnt. Shaft; Frnt.)① UJ317		
U-Joint (Frnt. Shaft; Frnt.)① UJ319			Brute Force Greaseable UJ246		
Clamp Kit (Frnt. Shaft; Frnt.) UJ318-10			Clamp Kit (Frnt. Shaft; Frnt.) UJ318-10		
U-Joint (Frnt. Shaft; Rr.)② [2] UJ379			U-Joint (Frnt. Shaft; Rr.)② [2] UJ534G		
Brute Force Greaseable UJ280			Brute Force Greaseable UJ235		
Brute Force Non Greaseable UJ269			Brute Force Non Greaseable UJ234		
U-Joint (Rr. Shaft; Frnt.)③ UJ458			U-Joint (Rr. Shaft; Frnt.)③ UJ316		
(For Aluminum Drive Shaft) UJ458C			Brute Force Greaseable UJ248		
Brute Force Non Greaseable UJ458BF			Clamp Kit (Rr. Shaft; Frnt.) UJ316-10		
U-Joint (Rr. Shaft; Rr.)④ UJ458			U-Joint (Rr. Shaft; Rr.)④ UJ316		
(For Aluminum Drive Shaft) UJ458C			Brute Force Greaseable UJ248		
Brute Force Non Greaseable UJ458BF			Clamp Kit (Rr. Shaft; Rr.) UJ316-10		
Centering Ball Kit UJ617			U-Joint (Wheel Joint)⑤ [2] UJ371		
H Yoke UJ647			Brute Force Greaseable UJ377		
1993-1988 Ramcharger w/ 2.125" Yoke: [Type			Brute Force Non Greaseable UJ371		
26]			Ball Seat Repair Kit UJ606		
U-Joint (Frnt. Shaft; Frnt.)① UJ317			Flange Yoke UJ626		
Brute Force Greaseable UJ246			H Yoke UJ646		
Clamp Kit (Frnt. Shaft; Frnt.) UJ318-10			1991-1988 W100 & W150 w/ 2 Joint Rr. Shaft:		
U-Joint (Frnt. Shaft; Rr.)② [2] UJ534G			[Type 26]		
Brute Force Greaseable UJ235			U-Joint (Frnt. Shaft; Frnt.)① UJ317		
Brute Force Non Greaseable UJ234			Brute Force Greaseable UJ246		
U-Joint (Rr. Shaft; Frnt.)③ UJ317			Clamp Kit (Frnt. Shaft; Frnt.) UJ318-10		
Brute Force Greaseable UJ246			U-Joint (Frnt. Shaft; Rr.)② [2] UJ534G		
Clamp Kit (Rr. Shaft; Frnt.) UJ318-10			Brute Force Greaseable UJ235		
U-Joint (Rr. Shaft; Rr.)④ UJ317			Brute Force Non Greaseable UJ234		
Brute Force Greaseable UJ246			U-Joint (Rr. Shaft; Frnt.)③ UJ317		
Clamp Kit (Rr. Shaft; Rr.) UJ318-10			Brute Force Greaseable UJ246		
U-Joint (Wheel Joint)⑤ [2] UJ371			Clamp Kit (Rr. Shaft; Frnt.) UJ318-10		
Brute Force Greaseable UJ377			U-Joint (Rr. Shaft; Rr.)④ UJ317		
Brute Force Non Greaseable UJ371			Brute Force Greaseable UJ246		
Ball Seat Repair Kit UJ606			Clamp Kit (Rr. Shaft; Rr.) UJ318-10		
Flange Yoke UJ626			U-Joint (Wheel Joint)⑤ [2] UJ371		
H Yoke UJ646			Brute Force Greaseable UJ377		
			Brute Force Non Greaseable UJ371		
			Ball Seat Repair Kit UJ606		
			Flange Yoke UJ626		
			H Yoke UJ646		

(Continued)

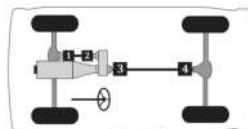

Type 13

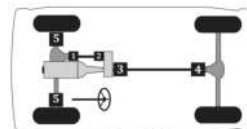

Type 26

Passenger cars, light & medium trucks

Dodge Truck 1/2 ton -- (Cont.)

MFG./YEAR	MODEL & LOCATION	PART NO.	MFG./YEAR	MODEL & LOCATION	PART NO.
-----------	------------------	----------	-----------	------------------	----------

Drive Shaft (4 W/D) (Cont.)

U-Joint (Cont.)

1991-1988 W100 & W150 w/ 3 Joint Rr. Shaft:

[Type 27]

U-Joint (Fr. Shaft; Frt.)⊙	UJ317
Brute Force Greaseable	UJ246
Clamp Kit (Fr. Shaft; Frt.)	UJ318-10
U-Joint (Fr. Shaft; Rr.)⊙ [2]	UJ534G
Brute Force Greaseable	UJ235
Brute Force Non Greaseable	UJ234
U-Joint (Rr. Shaft; Frt.)⊙	UJ317
Brute Force Greaseable	UJ246
Clamp Kit (Rr. Shaft; Frt.)	UJ318-10
U-Joint (Rr. Shaft; Ctr.)⊙	UJ317
Brute Force Greaseable	UJ246
Clamp Kit (Rr. Shaft; Ctr.)	UJ318-10
U-Joint (Rr. Shaft; Rr.)⊙	UJ317
Brute Force Greaseable	UJ246
Clamp Kit (Rr. Shaft; Rr.)	UJ318-10
U-Joint (Wheel Joint)⊙ [2]	UJ371
Brute Force Greaseable	UJ377
Brute Force Non Greaseable	UJ371
Ball Seat Repair Kit	UJ606
Flange Yoke	UJ626
H Yoke	UJ646

1990-1987 Dakota: [Type 13]

U-Joint (Fr. Shaft; Frt.)⊙	UJ319
Clamp Kit (Fr. Shaft; Frt.)	UJ318-10
U-Joint (Fr. Shaft; Rr.)⊙ [2]	UJ379
Brute Force Greaseable	UJ280
Brute Force Non Greaseable	UJ269
U-Joint (Rr. Shaft; Frt.)⊙	UJ317
Brute Force Greaseable	UJ246
Clamp Kit (Rr. Shaft; Frt.)	UJ318-10
U-Joint (Rr. Shaft; Rr.)⊙	UJ317
Brute Force Greaseable	UJ246
Clamp Kit (Rr. Shaft; Rr.)	UJ318-10
Centering Ball Kit	UJ617
H Yoke	UJ647

Drive Shaft (4 W/D) (Cont.)

U-Joint (Cont.)

1987-1982 W100 & W150 w/ 2 Joint Rr. Shaft:

[Type 26]

U-Joint (Fr. Shaft; Frt.)⊙	UJ315G
Brute Force Greaseable	UJ246
Clamp Kit (Fr. Shaft; Frt.)	UJ318-10
U-Joint (Fr. Shaft; Rr.)⊙ [2]	UJ534G
Brute Force Greaseable	UJ235
Brute Force Non Greaseable	UJ234
U-Joint (Rr. Shaft; Frt.)⊙	UJ315G
Brute Force Greaseable	UJ246
Clamp Kit (Rr. Shaft; Frt.)	UJ318-10
U-Joint (Rr. Shaft; Rr.)⊙	UJ315G
Brute Force Greaseable	UJ246
Clamp Kit (Rr. Shaft; Rr.)	UJ318-10
U-Joint (Wheel Joint)⊙ [2]	UJ371
Brute Force Greaseable	UJ377
Brute Force Non Greaseable	UJ371
Ball Seat Repair Kit	UJ606
Flange Yoke	UJ626
H Yoke	UJ646

1987-1982 W100 & W150 w/ 3 Joint Rr. Shaft:

[Type 27]

U-Joint (Fr. Shaft; Frt.)⊙	UJ315G
Brute Force Greaseable	UJ246
Clamp Kit (Fr. Shaft; Frt.)	UJ318-10
U-Joint (Fr. Shaft; Rr.)⊙ [2]	UJ534G
Brute Force Greaseable	UJ235
Brute Force Non Greaseable	UJ234
U-Joint (Rr. Shaft; Frt.)⊙	UJ315G
Brute Force Greaseable	UJ246
Clamp Kit (Rr. Shaft; Frt.)	UJ318-10
U-Joint (Rr. Shaft; Ctr.)⊙	UJ315G
Brute Force Greaseable	UJ246
Clamp Kit (Rr. Shaft; Ctr.)	UJ318-10
U-Joint (Rr. Shaft; Rr.)⊙	UJ315G
Brute Force Greaseable	UJ246
Clamp Kit (Rr. Shaft; Rr.)	UJ318-10
U-Joint (Wheel Joint)⊙ [2]	UJ371
Brute Force Greaseable	UJ377
Brute Force Non Greaseable	UJ371
Ball Seat Repair Kit	UJ606
Flange Yoke	UJ626
H Yoke	UJ646

(Continued)

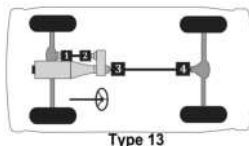

Type 13

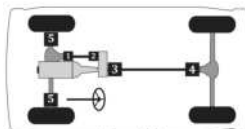

Type 26

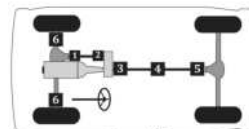

Type 27

MFG./YEAR	MODEL & LOCATION	PART NO.	MFG./YEAR	MODEL & LOCATION	PART NO.
Drive Shaft (4 W/D) (Cont.)			Drive Shaft (4 W/D) (Cont.)		
U-Joint (Cont.)			U-Joint (Cont.)		
1987-1977 Ramcharger w/ 2.125" Yoke: [Type 26]			1981-1977 W100 & W150 w/ 2 Joint Rr. Shaft & 2.125" Yokes: [Type 26]		
U-Joint (Frnt. Shaft; Frnt.)❶		UJ315G	U-Joint (Frnt. Shaft; Frnt.)❶		UJ315G
Brute Force Greaseable		UJ246	Brute Force Greaseable		UJ246
Clamp Kit (Frnt. Shaft; Frnt.)		UJ318-10	U-Joint (Frnt. Shaft; Rr.)❷	[2]	UJ534G
U-Joint (Frnt. Shaft; Rr.)❷	[2]	UJ534G	Brute Force Greaseable		UJ235
Brute Force Greaseable		UJ235	Brute Force Non Greaseable		UJ234
Brute Force Non Greaseable		UJ234	U-Joint (Rr. Shaft; Frnt.)❸		UJ315G
U-Joint (Rr. Shaft; Frnt.)❸		UJ315G	Brute Force Greaseable		UJ246
Brute Force Greaseable		UJ246	U-Joint (Rr. Shaft; Rr.)❹		UJ315G
Clamp Kit (Rr. Shaft; Frnt.)		UJ318-10	Brute Force Greaseable		UJ246
U-Joint (Rr. Shaft; Rr.)❹		UJ315G	U-Joint (Wheel Joint)❺	[2]	UJ371
Brute Force Greaseable		UJ246	Brute Force Greaseable		UJ377
Clamp Kit (Rr. Shaft; Rr.)		UJ318-10	Brute Force Non Greaseable		UJ371
U-Joint (Wheel Joint)❺	[2]	UJ371	Ball Seat Repair Kit		UJ606
Brute Force Greaseable		UJ377	Flange Yoke		UJ626
Brute Force Non Greaseable		UJ371	H Yoke		UJ646
Ball Seat Repair Kit		UJ606	1981-1977 W100 & W150 w/ 2 Joint Rr. Shaft & 2.625" Yokes: [Type 26]		
Flange Yoke		UJ626	U-Joint (Frnt. Shaft; Frnt.)❶		UJ315G
H Yoke		UJ646	Brute Force Greaseable		UJ246
1987-1977 Ramcharger w/ 2.625" Yoke: [Type 26]			U-Joint (Frnt. Shaft; Rr.)❷	[2]	UJ534G
U-Joint (Frnt. Shaft; Frnt.)❶		UJ315G	Brute Force Greaseable		UJ235
Brute Force Greaseable		UJ246	Brute Force Non Greaseable		UJ234
Clamp Kit (Frnt. Shaft; Frnt.)		UJ318-10	U-Joint (Rr. Shaft; Frnt.)❸		UJ315G
U-Joint (Frnt. Shaft; Rr.)❷	[2]	UJ534G	Brute Force Greaseable		UJ246
Brute Force Greaseable		UJ235	U-Joint (Rr. Shaft; Rr.)❹		UJ316
Brute Force Non Greaseable		UJ234	Brute Force Greaseable		UJ248
U-Joint (Rr. Shaft; Frnt.)❸		UJ315G	Clamp Kit (Rr. Shaft; Rr.)		UJ316-10
Brute Force Greaseable		UJ246	U-Joint (Wheel Joint)❺	[2]	UJ371
Clamp Kit (Rr. Shaft; Frnt.)		UJ318-10	Brute Force Greaseable		UJ377
U-Joint (Rr. Shaft; Rr.)❹		UJ316	Brute Force Non Greaseable		UJ371
Brute Force Greaseable		UJ248	Ball Seat Repair Kit		UJ606
Clamp Kit (Rr. Shaft; Rr.)		UJ316-10	Flange Yoke		UJ626
U-Joint (Wheel Joint)❺	[2]	UJ371	H Yoke		UJ646
Brute Force Greaseable		UJ377			(Continued)
Brute Force Non Greaseable		UJ371			
Ball Seat Repair Kit		UJ606			
Flange Yoke		UJ626			
H Yoke		UJ646			

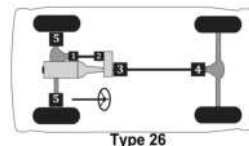

Passenger cars, light & medium trucks

Dodge Truck 1/2 ton -- (Cont.)

MFG./YEAR	MODEL & LOCATION	PART NO.	MFG./YEAR	MODEL & LOCATION	PART NO.
-----------	------------------	----------	-----------	------------------	----------

Drive Shaft (4 W/D) (Cont.)

U-Joint (Cont.)

1981-1977 W100 & W150 w/ 3 Joint Rr. Shaft & 2.125" Yokes: [Type 27]

U-Joint (Fr. Shaft; Frt.) [ⓐ]	UJ315G
Brute Force Greaseable	UJ246
U-Joint (Fr. Shaft; Rr.) [ⓑ]	[2] UJ534G
Brute Force Greaseable	UJ235
Brute Force Non Greaseable	UJ234
U-Joint (Rr. Shaft; Frt.) [ⓐ]	UJ315G
Brute Force Greaseable	UJ246
U-Joint (Rr. Shaft; Ctr.) [ⓐ]	UJ315G
Brute Force Greaseable	UJ246
U-Joint (Rr. Shaft; Rr.) [ⓑ]	UJ315G
Brute Force Greaseable	UJ246
U-Joint (Wheel Joint) [ⓐ]	[2] UJ371
Brute Force Greaseable	UJ377
Brute Force Non Greaseable	UJ371
Ball Seat Repair Kit	UJ606
Flange Yoke	UJ626
H Yoke	UJ646

1981-1977 W100 & W150 w/ 3 Joint Rr. Shaft & 2.625" Yokes: [Type 27]

U-Joint (Fr. Shaft; Frt.) [ⓐ]	UJ315G
Brute Force Greaseable	UJ246
U-Joint (Fr. Shaft; Rr.) [ⓑ]	[2] UJ534G
Brute Force Greaseable	UJ235
Brute Force Non Greaseable	UJ234
U-Joint (Rr. Shaft; Frt.) [ⓐ]	UJ315G
Brute Force Greaseable	UJ246
U-Joint (Rr. Shaft; Ctr.) [ⓐ]	UJ315G
Brute Force Greaseable	UJ246
U-Joint (Rr. Shaft; Rr.) [ⓑ]	UJ316
Brute Force Greaseable	UJ248
Clamp Kit (Rr. Shaft; Rr.)	UJ316-10
U-Joint (Wheel Joint) [ⓐ]	[2] UJ371
Brute Force Greaseable	UJ377
Brute Force Non Greaseable	UJ371
Ball Seat Repair Kit	UJ606
Flange Yoke	UJ626
H Yoke	UJ646

Drive Shaft (4 W/D) (Cont.)

U-Joint (Cont.)

1976 Ramcharger w/ 2.125" Yoke & Inner Lock Rings: [Type 26]

U-Joint (Fr. Shaft; Frt.) [ⓐ]	UJ315G
Brute Force Greaseable	UJ246
Clamp Kit (Fr. Shaft; Frt.)	UJ318-10
U-Joint (Fr. Shaft; Rr.) [ⓑ]	[2] UJ534G
Brute Force Greaseable	UJ235
Brute Force Non Greaseable	UJ234
U-Joint (Rr. Shaft; Frt.) [ⓐ]	UJ315G
Brute Force Greaseable	UJ246
Clamp Kit (Rr. Shaft; Frt.)	UJ318-10
U-Joint (Rr. Shaft; Rr.) [ⓑ]	UJ315G
Brute Force Greaseable	UJ246
Clamp Kit (Rr. Shaft; Rr.)	UJ318-10
U-Joint (Wheel Joint) [ⓐ]	[2] UJ371
Brute Force Greaseable	UJ377
Brute Force Non Greaseable	UJ371
Ball Seat Repair Kit	UJ606
Flange Yoke	UJ626
H Yoke	UJ646

1976 Ramcharger w/ 2.125" Yoke & Outer Lock Rings: [Type 26]

U-Joint (Fr. Shaft; Frt.) [ⓐ]	UJ315G
Brute Force Greaseable	UJ246
Clamp Kit (Fr. Shaft; Frt.)	UJ318-10
U-Joint (Fr. Shaft; Rr.) [ⓑ]	[2] UJ379
Brute Force Greaseable	UJ280
Brute Force Non Greaseable	UJ269
U-Joint (Rr. Shaft; Frt.) [ⓐ]	UJ315G
Brute Force Greaseable	UJ246
Clamp Kit (Rr. Shaft; Frt.)	UJ318-10
U-Joint (Rr. Shaft; Rr.) [ⓑ]	UJ315G
Brute Force Greaseable	UJ246
Clamp Kit (Rr. Shaft; Rr.)	UJ318-10
U-Joint (Wheel Joint) [ⓐ]	[2] UJ371
Brute Force Greaseable	UJ377
Brute Force Non Greaseable	UJ371
Centering Yoke	UJ607
H Yoke	UJ647

(Continued)

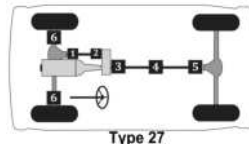
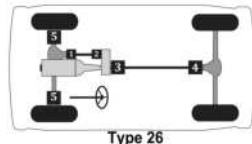

MFG./YEAR	MODEL & LOCATION	PART NO.	MFG./YEAR	MODEL & LOCATION	PART NO.
Drive Shaft (4 W/D) (Cont.)			Drive Shaft (4 W/D) (Cont.)		
U-Joint (Cont.)			U-Joint (Cont.)		
1976	Ramcharger w/ 2.625" Yoke & Inner Lock Rings: [Type 26]		1976-1975	W100 w/ Frt. Outer Lock Rings, 2 Joint Rr. Shaft & 2.125" Rr. Yoke: [Type 26]	
	U-Joint (Frt. Shaft; Frt.)①	UJ315G		U-Joint (Frt. Shaft; Frt.)①	UJ315G
	Brute Force Greaseable	UJ246		Brute Force Greaseable	UJ246
	Clamp Kit (Frt. Shaft; Frt.)	UJ318-10		U-Joint (Frt. Shaft; Rr.)②	UJ379
	U-Joint (Frt. Shaft; Rr.)②	[2] UJ534G		Brute Force Greaseable	[2] UJ280
	Brute Force Greaseable	UJ235		Brute Force Non Greaseable	UJ269
	Brute Force Non Greaseable	UJ234		U-Joint (Rr. Shaft; Frt.)③	UJ315G
	U-Joint (Rr. Shaft; Frt.)③	UJ315G		Brute Force Greaseable	UJ246
	Brute Force Greaseable	UJ246		U-Joint (Rr. Shaft; Rr.)④	UJ315G
	Clamp Kit (Rr. Shaft; Frt.)	UJ318-10		Brute Force Greaseable	UJ246
	U-Joint (Rr. Shaft; Rr.)④	UJ316		U-Joint (Wheel Joint)⑤	[2] UJ371
	Brute Force Greaseable	UJ248		Brute Force Greaseable	UJ377
	Clamp Kit (Rr. Shaft; Rr.)	UJ316-10		Brute Force Non Greaseable	UJ371
	U-Joint (Wheel Joint)⑤	[2] UJ371		Centering Yoke	UJ607
	Brute Force Greaseable	UJ377		H Yoke	UJ647
	Brute Force Non Greaseable	UJ371		1976-1975 W100 w/ Frt. Inner Lock Rings, 2 Joint Rr. Shaft & 2.625" Rr. Yoke: [Type 26]	
	Ball Seat Repair Kit	UJ606		U-Joint (Frt. Shaft; Frt.)①	UJ315G
	Flange Yoke	UJ626		Brute Force Greaseable	UJ246
	H Yoke	UJ646		U-Joint (Frt. Shaft; Rr.)②	[2] UJ534G
1976	Ramcharger w/ 2.625" Yoke & Outer Lock Rings: [Type 26]			Brute Force Greaseable	UJ235
	U-Joint (Frt. Shaft; Frt.)①	UJ315G		Brute Force Non Greaseable	UJ234
	Brute Force Greaseable	UJ246		U-Joint (Rr. Shaft; Frt.)③	UJ315G
	Clamp Kit (Frt. Shaft; Frt.)	UJ318-10		Brute Force Greaseable	UJ246
	U-Joint (Frt. Shaft; Rr.)②	[2] UJ379		U-Joint (Rr. Shaft; Rr.)④	UJ316
	Brute Force Greaseable	UJ280		Brute Force Greaseable	UJ248
	Brute Force Non Greaseable	UJ269		Clamp Kit (Rr. Shaft; Rr.)	UJ316-10
	U-Joint (Rr. Shaft; Frt.)③	UJ315G		U-Joint (Wheel Joint)⑤	[2] UJ371
	Brute Force Greaseable	UJ246		Brute Force Greaseable	UJ377
	U-Joint (Rr. Shaft; Rr.)④	UJ316		Brute Force Non Greaseable	UJ371
	Brute Force Greaseable	UJ248		Ball Seat Repair Kit	UJ606
	Clamp Kit (Rr. Shaft; Rr.)	UJ316-10		Flange Yoke	UJ626
	U-Joint (Wheel Joint)⑤	[2] UJ371		H Yoke	UJ646
	Brute Force Greaseable	UJ377			
	Brute Force Non Greaseable	UJ371			
	Centering Yoke	UJ607			
	H Yoke	UJ647			

(Continued)

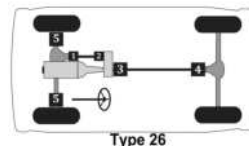

Passenger cars, light & medium trucks

Dodge Truck 1/2 ton -- (Cont.)

MFG./YEAR	MODEL & LOCATION	PART NO.	MFG./YEAR	MODEL & LOCATION	PART NO.
Drive Shaft (4 W/D) (Cont.)			Drive Shaft (4 W/D) (Cont.)		
U-Joint (Cont.)			U-Joint (Cont.)		
1976-1975 W100 w/ Frt. Inner Lock Rings, 2 Joint			1976-1975 W100 w/ Frt. Inner Lock Rings, 3 Joint		
Rr. Shaft & 2.125" Rr. Yoke: [Type 26]			Rr. Shaft & 2.125" Rr. Yoke: [Type 27]		
U-Joint (Frt. Shaft; Frt.)ⓐ		UJ315G	U-Joint (Frt. Shaft; Frt.)ⓐ		UJ315G
Brute Force Greaseable		UJ246	Brute Force Greaseable		UJ246
U-Joint (Frt. Shaft; Rr.)ⓑ	[2]	UJ534G	U-Joint (Frt. Shaft; Rr.)ⓑ	[2]	UJ534G
Brute Force Greaseable		UJ235	Brute Force Greaseable		UJ235
Brute Force Non Greaseable		UJ234	Brute Force Non Greaseable		UJ234
U-Joint (Rr. Shaft; Frt.)ⓐ		UJ315G	U-Joint (Rr. Shaft; Frt.)ⓐ		UJ315G
Brute Force Greaseable		UJ246	Brute Force Greaseable		UJ246
U-Joint (Rr. Shaft; Rr.)ⓑ		UJ315G	U-Joint (Rr. Shaft; Ctr.)ⓐ		UJ315G
Brute Force Greaseable		UJ246	Brute Force Greaseable		UJ246
U-Joint (Wheel Joint)ⓐ	[2]	UJ371	U-Joint (Rr. Shaft; Rr.)ⓑ		UJ315G
Brute Force Greaseable		UJ377	Brute Force Greaseable		UJ246
Brute Force Non Greaseable		UJ371	U-Joint (Wheel Joint)ⓐ	[2]	UJ371
Ball Seat Repair Kit		UJ606	Brute Force Greaseable		UJ377
Flange Yoke		UJ626	Brute Force Non Greaseable		UJ371
H Yoke		UJ646	Ball Seat Repair Kit		UJ606
1976-1975 W100 w/ Frt. Outer Lock Rings, 2 Joint			1976-1975 W100 w/ Frt. Inner Lock Rings, 3 Joint		
Rr. Shaft & 2.625" Rr. Yoke: [Type 26]			Rr. Shaft & 2.625" Rr. Yoke: [Type 27]		
U-Joint (Frt. Shaft; Frt.)ⓐ		UJ315G	U-Joint (Frt. Shaft; Frt.)ⓐ		UJ315G
Brute Force Greaseable		UJ246	Brute Force Greaseable		UJ246
U-Joint (Frt. Shaft; Rr.)ⓑ	[2]	UJ379	U-Joint (Frt. Shaft; Rr.)ⓑ	[2]	UJ534G
Brute Force Greaseable		UJ280	Brute Force Greaseable		UJ235
Brute Force Non Greaseable		UJ269	Brute Force Non Greaseable		UJ234
U-Joint (Rr. Shaft; Frt.)ⓐ		UJ315G	U-Joint (Rr. Shaft; Frt.)ⓐ		UJ315G
Brute Force Greaseable		UJ246	Brute Force Greaseable		UJ246
U-Joint (Rr. Shaft; Rr.)ⓑ		UJ316	U-Joint (Rr. Shaft; Ctr.)ⓐ		UJ315G
Brute Force Greaseable		UJ248	Brute Force Greaseable		UJ246
Clamp Kit (Rr. Shaft; Rr.)		UJ316-10	U-Joint (Rr. Shaft; Rr.)ⓑ		UJ316
U-Joint (Wheel Joint)ⓐ	[2]	UJ371	Brute Force Greaseable		UJ248
Brute Force Greaseable		UJ377	Clamp Kit (Rr. Shaft; Rr.)		UJ316-10
Brute Force Non Greaseable		UJ371	U-Joint (Wheel Joint)ⓐ	[2]	UJ371
Centering Yoke		UJ607	Brute Force Greaseable		UJ377
H Yoke		UJ647	Brute Force Non Greaseable		UJ371
			Ball Seat Repair Kit		UJ606
			H Yoke		UJ646

(Continued)

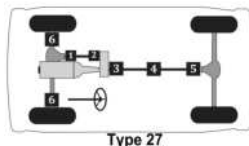
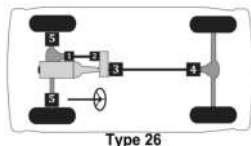

242 ▲ For Use w/ 1.063" Bearing Cap Application. ⓐ For Use w/ 1.188" Bearing Cap Application. ◇ For Use w/ Inner Lock Ring Application on Half Shaft. □ For Use w/ Outer Lock Ring Application on Half Shaft.

MFG./YEAR	MODEL & LOCATION	PART NO.	MFG./YEAR	MODEL & LOCATION	PART NO.
Drive Shaft (4 W/D) (Cont.)			Drive Shaft (4 W/D) (Cont.)		
U-Joint (Cont.)			U-Joint (Cont.)		
1976-1975 W100 w/ Frt. Outer Lock Rings, 3 Joint Rr. Shaft & 2.125" Rr. Yoke: [Type 27]			1975-1974 Ramcharger w/ 2.125" Yoke: [Type 26]		
	U-Joint (Frt. Shaft; Frt.)①	UJ315G		U-Joint (Frt. Shaft; Frt.)①	UJ315G
	Brute Force Greaseable	UJ246		Brute Force Greaseable	UJ246
	U-Joint (Frt. Shaft; Rr.)②	[2] UJ379		U-Joint (Frt. Shaft; Rr.)②	[2] UJ379
	Brute Force Greaseable	UJ280		Brute Force Greaseable	UJ280
	Brute Force Non Greaseable	UJ269		Brute Force Non Greaseable	UJ269
	U-Joint (Rr. Shaft; Frt.)③	UJ315G		U-Joint (Rr. Shaft; Frt.)③	UJ315G
	Brute Force Greaseable	UJ246		Brute Force Greaseable	UJ246
	U-Joint (Rr. Shaft; Ctr.)④	UJ315G		U-Joint (Rr. Shaft; Ctr.)④	UJ315G
	Brute Force Greaseable	UJ246		Brute Force Greaseable	UJ246
	U-Joint (Rr. Shaft; Rr.)⑤	UJ315G		U-Joint (Rr. Shaft; Rr.)⑤	UJ315G
	Brute Force Greaseable	UJ246		Brute Force Greaseable	UJ246
	U-Joint (Wheel Joint)⑥	[2] UJ371		U-Joint (Wheel Joint)⑥	[2] UJ371
	Brute Force Greaseable	UJ377		Brute Force Greaseable	UJ377
	Brute Force Non Greaseable	UJ371		Brute Force Non Greaseable	UJ371
	Centering Yoke	UJ607		Centering Yoke	UJ607
	H Yoke	UJ647		H Yoke	UJ647
1976-1975 W100 w/ Frt. Outer Lock Rings, 3 Joint Rr. Shaft & 2.625" Rr. Yoke: [Type 27]			1975-1974 Ramcharger w/ 2.625" Yoke: [Type 26]		
	U-Joint (Frt. Shaft; Frt.)①	UJ315G		U-Joint (Frt. Shaft; Frt.)①	UJ315G
	Brute Force Greaseable	UJ246		Brute Force Greaseable	UJ246
	U-Joint (Frt. Shaft; Rr.)②	[2] UJ379		U-Joint (Frt. Shaft; Rr.)②	[2] UJ379
	Brute Force Greaseable	UJ280		Brute Force Greaseable	UJ280
	Brute Force Non Greaseable	UJ269		Brute Force Non Greaseable	UJ269
	U-Joint (Rr. Shaft; Frt.)③	UJ315G		U-Joint (Rr. Shaft; Frt.)③	UJ315G
	Brute Force Greaseable	UJ246		Brute Force Greaseable	UJ246
	U-Joint (Rr. Shaft; Ctr.)④	UJ315G		U-Joint (Rr. Shaft; Ctr.)④	UJ315G
	Brute Force Greaseable	UJ246		Brute Force Greaseable	UJ246
	U-Joint (Rr. Shaft; Rr.)⑤	UJ316		U-Joint (Rr. Shaft; Rr.)⑤	UJ316
	Brute Force Greaseable	UJ248		Brute Force Greaseable	UJ248
	Clamp Kit (Rr. Shaft; Rr.)	UJ316-10		Clamp Kit (Rr. Shaft; Rr.)	UJ316-10
	U-Joint (Wheel Joint)⑥	[2] UJ371		U-Joint (Wheel Joint)⑥	[2] UJ371
	Brute Force Greaseable	UJ377		Brute Force Greaseable	UJ377
	Brute Force Non Greaseable	UJ371		Brute Force Non Greaseable	UJ371
	Centering Yoke	UJ607		Centering Yoke	UJ607
	H Yoke	UJ647		H Yoke	UJ647

(Continued)

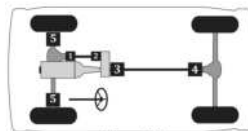

Type 26

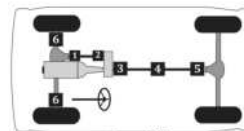

Type 27

Passenger cars, light & medium trucks

Dodge Truck 1/2 ton -- (Cont.)

MFG./YEAR	MODEL & LOCATION	PART NO.	MFG./YEAR	MODEL & LOCATION	PART NO.
Drive Shaft (4 W/D) (Cont.)			Drive Shaft (4 W/D) (Cont.)		
U-Joint (Cont.)			U-Joint (Cont.)		
1974-1973 W100: [Type 34]			1972 W100 w/ 1.063" Dia. Wheel Joint Brg.		
U-Joint (Frnt. Shaft; Frnt.)ⓐ UJ315G			Caps: [Type 34]		
<i>Brute Force Greaseable</i> UJ246			U-Joint (Frnt. Shaft; Frnt.)ⓐ UJ315G		
Clamp Kit (Frnt. Shaft, Frnt.) UJ318-10			<i>Brute Force Greaseable</i> UJ246		
U-Joint (Frnt. Shaft; Rr.)ⓑ UJ315G			Clamp Kit (Frnt. Shaft, Frnt.) UJ318-10		
<i>Brute Force Greaseable</i> UJ246			U-Joint (Frnt. Shaft; Rr.)ⓑ UJ315G		
Clamp Kit (Frnt. Shaft, Rr.) UJ318-10			<i>Brute Force Greaseable</i> UJ246		
U-Joint (Intmd. Shaft; Frnt.)ⓐ UJ315G			Clamp Kit (Frnt. Shaft, Rr.) UJ318-10		
<i>Brute Force Greaseable</i> UJ246			U-Joint (Intmd. Shaft; Frnt.)ⓐ UJ315G		
Clamp Kit (Intmd. Shaft; Frnt.) UJ318-10			<i>Brute Force Greaseable</i> UJ246		
U-Joint (Intmd. Shaft; Rr.)ⓑ UJ315G			Clamp Kit (Intmd. Shaft; Frnt.) UJ318-10		
<i>Brute Force Greaseable</i> UJ246			U-Joint (Intmd. Shaft; Rr.)ⓑ UJ315G		
Clamp Kit (Intmd. Shaft; Rr.) UJ318-10			<i>Brute Force Greaseable</i> UJ246		
U-Joint (Rr. Shaft; Frnt.)ⓐ UJ315G			Clamp Kit (Intmd. Shaft; Rr.) UJ318-10		
<i>Brute Force Greaseable</i> UJ246			U-Joint (Rr. Shaft; Frnt.)ⓐ UJ315G		
Clamp Kit (Rr. Shaft, Frnt.) UJ318-10			<i>Brute Force Greaseable</i> UJ246		
U-Joint (Rr. Shaft; Rr.)ⓑ UJ315G			Clamp Kit (Rr. Shaft, Frnt.) UJ318-10		
<i>Brute Force Greaseable</i> UJ246			U-Joint (Rr. Shaft; Rr.)ⓑ UJ315G		
Clamp Kit (Rr. Shaft, Rr.) UJ318-10			<i>Brute Force Greaseable</i> UJ246		
U-Joint (Wheel Joint)ⓓ [2] UJ371			Clamp Kit (Rr. Shaft, Rr.) UJ318-10		
<i>Brute Force Greaseable</i> UJ377			U-Joint (Wheel Joint)ⓓ [2] UJ365		
<i>Brute Force Non Greaseable</i> UJ371			<i>Brute Force Greaseable</i> UJ378		
1972 W100 w/ 1.188" Dia. Wheel Joint Brg.			<i>Brute Force Non Greaseable</i> UJ365		
Caps: [Type 34]			1971-1961 W100: [Type 34]		
U-Joint (Frnt. Shaft; Frnt.)ⓐ UJ315G			U-Joint (Frnt. Shaft; Frnt.)ⓐ UJ315G		
<i>Brute Force Greaseable</i> UJ246			<i>Brute Force Greaseable</i> UJ246		
Clamp Kit (Frnt. Shaft, Frnt.) UJ318-10			Clamp Kit (Frnt. Shaft, Frnt.) UJ318-10		
U-Joint (Frnt. Shaft; Rr.)ⓑ UJ315G			U-Joint (Frnt. Shaft; Rr.)ⓑ UJ315G		
<i>Brute Force Greaseable</i> UJ246			<i>Brute Force Greaseable</i> UJ246		
Clamp Kit (Frnt. Shaft, Rr.) UJ318-10			Clamp Kit (Frnt. Shaft, Rr.) UJ318-10		
U-Joint (Intmd. Shaft; Frnt.)ⓐ UJ315G			U-Joint (Intmd. Shaft; Frnt.)ⓐ UJ315G		
<i>Brute Force Greaseable</i> UJ246			<i>Brute Force Greaseable</i> UJ246		
Clamp Kit (Intmd. Shaft; Frnt.) UJ318-10			Clamp Kit (Intmd. Shaft; Frnt.) UJ318-10		
U-Joint (Intmd. Shaft; Rr.)ⓑ UJ315G			U-Joint (Intmd. Shaft; Rr.)ⓑ UJ315G		
<i>Brute Force Greaseable</i> UJ246			<i>Brute Force Greaseable</i> UJ246		
Clamp Kit (Intmd. Shaft; Rr.) UJ318-10			Clamp Kit (Intmd. Shaft; Rr.) UJ318-10		
U-Joint (Rr. Shaft; Frnt.)ⓐ UJ315G			U-Joint (Rr. Shaft; Frnt.)ⓐ UJ315G		
<i>Brute Force Greaseable</i> UJ246			<i>Brute Force Greaseable</i> UJ246		
Clamp Kit (Rr. Shaft, Frnt.) UJ318-10			Clamp Kit (Rr. Shaft, Frnt.) UJ318-10		
U-Joint (Rr. Shaft; Rr.)ⓑ UJ315G			U-Joint (Rr. Shaft; Rr.)ⓑ UJ315G		
<i>Brute Force Greaseable</i> UJ246			<i>Brute Force Greaseable</i> UJ246		
Clamp Kit (Rr. Shaft, Rr.) UJ318-10			Clamp Kit (Rr. Shaft, Rr.) UJ318-10		
U-Joint (Wheel Joint)ⓓ [2] UJ371			U-Joint (Wheel Joint)ⓓ [2] UJ365		
<i>Brute Force Greaseable</i> UJ377			<i>Brute Force Greaseable</i> UJ378		
<i>Brute Force Non Greaseable</i> UJ371			<i>Brute Force Non Greaseable</i> UJ365		

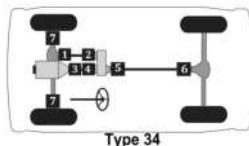

244 ▲ For Use w/ 1.063" Bearing Cap Application. ⓐ For Use w/ 1.188" Bearing Cap Application. ◇ For Use w/ Inner Lock Ring Application on Half Shaft. □ For Use w/ Outer Lock Ring Application on Half Shaft.

MFG./YEAR	MODEL & LOCATION	PART NO.	MFG./YEAR	MODEL & LOCATION	PART NO.
Drive Shaft (2 W/D)			Drive Shaft (2 W/D) (Cont.)		
U-Joint			U-Joint (Cont.)		
2010-2008 R2500 w/ 2 Joint Shaft & Gas Eng.:			2007-2003 R2500 w/ 3 Joint Shaft & 1.375" Dia.		
[Type 1]			Brg. Cap: [Type 2]		
U-Joint (Front)Ⓢ		UJ330A	U-Joint (Front)Ⓢ		UJ351A
Brute Force Greaseable		UJ295A	Brute Force Non Greaseable		UJ351ABF
U-Joint (Rear)Ⓢ		UJ330A	U-Joint (Center)Ⓢ		UJ351A
Brute Force Greaseable		UJ295A	Brute Force Non Greaseable		UJ351ABF
2010-2008 R2500 w/ 2 Joint Shaft & Diesel Eng.:			U-Joint (Rear)Ⓢ		
[Type 1]			UJ351A		
U-Joint (Front)Ⓢ		UJ351A	Brute Force Non Greaseable		UJ351ABF
Brute Force Non Greaseable		UJ351ABF	2002-1999 R2500 w/ 2 Joint Shaft: [Type 1]		
U-Joint (Rear)Ⓢ		UJ351A	U-Joint (Front)Ⓢ		UJ330
Brute Force Non Greaseable		UJ351ABF	Brute Force Greaseable		UJ295
2010-2008 R2500 w/ 3 Joint Shaft & Gas Eng.:			(For Aluminum Drive Shaft)		
[Type 2]			UJ330C		
U-Joint (Front)Ⓢ		UJ330A	Clamp Kit (Front)		UJ331-10
Brute Force Greaseable		UJ295A	U-Joint (Rear)Ⓢ		UJ330
U-Joint (Center)Ⓢ		UJ330A	Brute Force Greaseable		UJ295
Brute Force Greaseable		UJ295A	(For Aluminum Drive Shaft)		
U-Joint (Rear)Ⓢ		UJ330A	UJ330C		
Brute Force Greaseable		UJ295A	Clamp Kit (Rear)		
2010-2008 R2500 w/ 3 Joint Shaft & Diesel Eng.:			UJ331-10		
[Type 2]			2002-1997 R2500 w/ 3 Joint Shaft: [Type 2]		
U-Joint (Front)Ⓢ		UJ351A	U-Joint (Front)Ⓢ		UJ330
Brute Force Non Greaseable		UJ351ABF	Brute Force Greaseable		UJ295
U-Joint (Center)Ⓢ		UJ351A	(For Aluminum Drive Shaft)		
Brute Force Non Greaseable		UJ351ABF	UJ330C		
U-Joint (Rear)Ⓢ		UJ351A	Clamp Kit (Front)		
Brute Force Non Greaseable		UJ351ABF	UJ331-10		
2007-2003 R2500 w/ 2 Joint Shaft & 1.188" Dia.			U-Joint (Center)Ⓢ		
Brg. Cap: [Type 1]			UJ330		
U-Joint (Front)Ⓢ		UJ330A	Brute Force Greaseable		UJ295
Brute Force Greaseable		UJ295A	(For Aluminum Drive Shaft)		
U-Joint (Rear)Ⓢ		UJ330A	UJ330C		
Brute Force Greaseable		UJ295A	Clamp Kit (Center)		
2007-2003 R2500 w/ 2 Joint Shaft & 1.375" Dia.			UJ331-10		
Brg. Cap: [Type 1]			U-Joint (Rear)Ⓢ		
U-Joint (Front)Ⓢ		UJ351A	UJ330		
Brute Force Non Greaseable		UJ351ABF	Brute Force Greaseable		
U-Joint (Rear)Ⓢ		UJ351A	UJ295		
Brute Force Non Greaseable		UJ351ABF	(For Aluminum Drive Shaft)		
2007-2003 R2500 w/ 2 Joint Shaft & 1.188" Dia.			UJ330C		
Brg. Cap: [Type 2]			Clamp Kit (Rear)		
U-Joint (Front)Ⓢ		UJ330A	UJ331-10		
Brute Force Greaseable		UJ295A	1998-1997 R2500 w/ 2 Joint Shaft, 8 Cyl. Eng. & Auto. Trans.: [Type 1]		
U-Joint (Center)Ⓢ		UJ330A	U-Joint (Front)Ⓢ		UJ458
Brute Force Greaseable		UJ295A	(For Aluminum Drive Shaft)		
U-Joint (Rear)Ⓢ		UJ330A	UJ458C		
Brute Force Greaseable		UJ295A	Brute Force Non Greaseable		
2007-2003 R2500 w/ 3 Joint Shaft & 1.188" Dia.			UJ458BF		
Brg. Cap: [Type 1]			U-Joint (Rear)Ⓢ		
U-Joint (Front)Ⓢ		UJ330A	UJ458		
Brute Force Greaseable		UJ295A	(For Aluminum Drive Shaft)		
U-Joint (Center)Ⓢ		UJ330A	UJ458C		
Brute Force Greaseable		UJ295A	Brute Force Non Greaseable		
U-Joint (Rear)Ⓢ		UJ330A	UJ458BF		
Brute Force Greaseable		UJ295A	1998-1997 R2500 w/ 2 Joint Shaft Exc. 8 Cyl. Eng & Auto. Trans.: [Type 1]		
2007-2003 R2500 w/ 3 Joint Shaft & 1.188" Dia.			U-Joint (Front)Ⓢ		
Brg. Cap: [Type 2]			UJ330		
U-Joint (Front)Ⓢ		UJ330A	Brute Force Greaseable		UJ295
Brute Force Greaseable		UJ295A	(For Aluminum Drive Shaft)		
U-Joint (Center)Ⓢ		UJ330A	UJ330C		
Brute Force Greaseable		UJ295A	Clamp Kit (Front)		
U-Joint (Rear)Ⓢ		UJ330A	UJ331-10		
Brute Force Greaseable		UJ295A	U-Joint (Rear)Ⓢ		
2007-2003 R2500 w/ 3 Joint Shaft & 1.188" Dia.			UJ330		
Brg. Cap: [Type 1]			Brute Force Greaseable		
U-Joint (Front)Ⓢ		UJ330A	UJ295		
Brute Force Greaseable		UJ295A	(For Aluminum Drive Shaft)		
U-Joint (Center)Ⓢ		UJ330A	UJ330C		
Brute Force Greaseable		UJ295A	Clamp Kit (Rear)		
U-Joint (Rear)Ⓢ		UJ330A	UJ331-10		
Brute Force Greaseable		UJ295A	(Continued)		

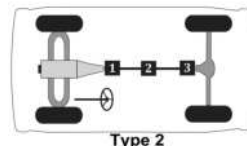
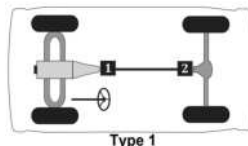

Passenger cars, light & medium trucks

Dodge Truck 3/4 ton -- (Cont.)

MFG./YEAR	MODEL & LOCATION	PART NO.	MFG./YEAR	MODEL & LOCATION	PART NO.
Drive Shaft (2 W/D) (Cont.)			Drive Shaft (2 W/D) (Cont.)		
U-Joint (Cont.)			U-Joint (Cont.)		
1996-1994 R2500 w/ 2 Joint Shaft, Diesel & 10 Cyl. Eng.: [Type 1]			1993-1989 D250 w/ 2 Joint Shaft, 2.625" Yoke & Gas Eng.: [Type 1]		
U-Joint (Front)❶		UJ330	U-Joint (Front)❶		UJ316
Brute Force Greaseable		UJ295	Brute Force Greaseable		UJ248
(For Aluminum Drive Shaft)		UJ330C	Clamp Kit (Front)		UJ316-10
Clamp Kit (Front)		UJ331-10	U-Joint (Rear)❷		UJ316
U-Joint (Rear)❷		UJ330	Brute Force Greaseable		UJ248
Brute Force Greaseable		UJ295	Clamp Kit (Rear)		UJ316-10
(For Aluminum Drive Shaft)		UJ330C	1993-1989 D250 w/ 3 Joint Shaft, 2.125" Yoke & Gas Eng.: [Type 2]		
Clamp Kit (Rear)		UJ331-10	U-Joint (Front)❶		UJ317
1996-1994 R2500 w/ 3 Joint Shaft, Diesel & 10 Cyl. Eng.: [Type 2]			Brute Force Greaseable		UJ246
U-Joint (Front)❶		UJ330	Clamp Kit (Front)		UJ318-10
Brute Force Greaseable		UJ295	U-Joint (Center)❸		UJ317
(For Aluminum Drive Shaft)		UJ330C	Brute Force Greaseable		UJ246
Clamp Kit (Front)		UJ331-10	Clamp Kit (Center)		UJ318-10
U-Joint (Center)❸		UJ330	U-Joint (Rear)❹		UJ317
Brute Force Greaseable		UJ295	Brute Force Greaseable		UJ246
(For Aluminum Drive Shaft)		UJ330C	Clamp Kit (Rear)		UJ318-10
Clamp Kit (Center)		UJ331-10	1993-1989 D250 w/ 3 Joint Shaft, 2.625" Yoke & Gas Eng.: [Type 2]		
U-Joint (Rear)❹		UJ330	U-Joint (Front)❶		UJ316
Brute Force Greaseable		UJ295	Brute Force Greaseable		UJ248
(For Aluminum Drive Shaft)		UJ330C	Clamp Kit (Front)		UJ316-10
Clamp Kit (Rear)		UJ331-10	U-Joint (Center)❸		UJ316
1996-1994 R2500 w/ 2 Joint Shaft & 8 Cyl. Gas Eng.: [Type 1]			Brute Force Greaseable		UJ248
U-Joint (Front)❶		UJ316	Clamp Kit (Center)		UJ316-10
Brute Force Greaseable		UJ248	U-Joint (Rear)❹		UJ316
Clamp Kit (Front)		UJ316-10	Brute Force Greaseable		UJ248
U-Joint (Rear)❷		UJ316	Clamp Kit (Rear)		UJ316-10
Brute Force Greaseable		UJ248	1993-1989 D250 w/ 2 Joint Shaft & Diesel Eng.: [Type 1]		
Clamp Kit (Rear)		UJ316-10	U-Joint (Front)❶		UJ330
1996-1994 R2500 w/ 3 Joint Shaft & 8 Cyl. Gas Eng.: [Type 2]			Brute Force Greaseable		UJ295
U-Joint (Front)❶		UJ316	(For Aluminum Drive Shaft)		UJ330C
Brute Force Greaseable		UJ248	Clamp Kit (Front)		UJ331-10
Clamp Kit (Front)		UJ316-10	U-Joint (Rear)❷		UJ330
U-Joint (Center)❸		UJ316	Brute Force Greaseable		UJ295
Brute Force Greaseable		UJ248	(For Aluminum Drive Shaft)		UJ330C
Clamp Kit (Center)		UJ316-10	Clamp Kit (Rear)		UJ331-10
U-Joint (Rear)❹		UJ316			(Continued)
Brute Force Greaseable		UJ248			
Clamp Kit (Rear)		UJ316-10			
1993-1989 D250 w/ 2 Joint Shaft, 2.125" Yoke & Gas Eng.: [Type 1]					
U-Joint (Front)❶		UJ317			
Brute Force Greaseable		UJ246			
Clamp Kit (Front)		UJ318-10			
U-Joint (Rear)❷		UJ317			
Brute Force Greaseable		UJ246			
Clamp Kit (Rear)		UJ318-10			

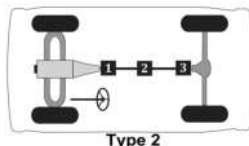
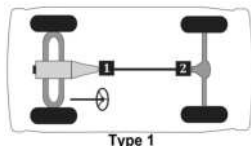

MFG./YEAR	MODEL & LOCATION	PART NO.	MFG./YEAR	MODEL & LOCATION	PART NO.
Drive Shaft (2 W/D) (Cont.)			Drive Shaft (2 W/D) (Cont.)		
U-Joint (Cont.)			U-Joint (Cont.)		
1993-1989 D250 w/ 3 Joint Shaft & Diesel Eng.:			1981-1970 D200 & D250 w/ 3 Joint Shaft & 2.125"		
[Type 2]			Yoke: [Type 2]		
U-Joint (Front)Ⓢ		UJ330	U-Joint (Front)Ⓢ		UJ315G
Brute Force Greaseable		UJ295	Brute Force Greaseable		UJ246
(For Aluminum Drive Shaft)		UJ330C	Clamp Kit		UJ318-10
Clamp Kit (Front)		UJ331-10	U-Joint (Center)Ⓢ		UJ315G
U-Joint (Center)Ⓢ		UJ330	Brute Force Greaseable		UJ246
Brute Force Greaseable		UJ295	Clamp Kit		UJ318-10
(For Aluminum Drive Shaft)		UJ330C	U-Joint (Rear)Ⓢ		UJ315G
Clamp Kit (Center)		UJ331-10	Brute Force Greaseable		UJ246
U-Joint (Rear)Ⓢ		UJ330	Clamp Kit		UJ318-10
Brute Force Greaseable		UJ295	1981-1970 D200 & D250 w/ 3 Joint Shaft & 2.625"		
(For Aluminum Drive Shaft)		UJ330C	Yoke: [Type 2]		
Clamp Kit (Rear)		UJ331-10	U-Joint (Front)Ⓢ		UJ316
1988-1982 D250 w/ 2 Joint Shaft: [Type 1]			Brute Force Greaseable		UJ248
U-Joint (Front)Ⓢ		UJ315G	Clamp Kit (Front)		UJ316-10
Brute Force Greaseable		UJ246	U-Joint (Center)Ⓢ		UJ316
Clamp Kit		UJ318-10	Brute Force Greaseable		UJ248
U-Joint (Rear)Ⓢ		UJ315G	Clamp Kit (Center)		UJ316-10
Brute Force Greaseable		UJ246	U-Joint (Rear)Ⓢ		UJ316
Clamp Kit		UJ318-10	Brute Force Greaseable		UJ248
1988-1982 D250 w/ 3 Joint Shaft: [Type 2]			Clamp Kit (Rear)		UJ316-10
U-Joint (Front)Ⓢ		UJ315G	1969-1961 D200 w/ 2 Joint Shaft: [Type 1]		
Brute Force Greaseable		UJ246	U-Joint (Front)Ⓢ		UJ315G
Clamp Kit		UJ318-10	Brute Force Greaseable		UJ246
U-Joint (Center)Ⓢ		UJ315G	Clamp Kit		UJ318-10
Brute Force Greaseable		UJ246	U-Joint (Rear)Ⓢ		UJ315G
Clamp Kit		UJ318-10	Brute Force Greaseable		UJ246
U-Joint (Rear)Ⓢ		UJ315G	Clamp Kit		UJ318-10
Brute Force Greaseable		UJ246	1969-1961 D200 w/ 3 Joint Shaft: [Type 2]		
Clamp Kit		UJ318-10	U-Joint (Front)Ⓢ		UJ315G
1981-1970 D200 & D250 w/ 2 Joint Shaft & 2.125"			Brute Force Greaseable		UJ246
Yoke: [Type 1]			Clamp Kit		UJ318-10
U-Joint (Front)Ⓢ		UJ315G	U-Joint (Center)Ⓢ		UJ315G
Brute Force Greaseable		UJ246	Brute Force Greaseable		UJ246
Clamp Kit		UJ318-10	Clamp Kit		UJ318-10
U-Joint (Rear)Ⓢ		UJ315G	U-Joint (Rear)Ⓢ		UJ315G
Brute Force Greaseable		UJ246	Brute Force Greaseable		UJ246
Clamp Kit		UJ318-10	Clamp Kit		UJ318-10
1981-1970 D200 & D250 w/ 2 Joint Shaft & 2.625"			(Continued)		
Yoke: [Type 1]					
U-Joint (Front)Ⓢ		UJ316			
Brute Force Greaseable		UJ248			
Clamp Kit (Front)		UJ316-10			
U-Joint (Rear)Ⓢ		UJ316			
Brute Force Greaseable		UJ248			
Clamp Kit (Rear)		UJ316-10			

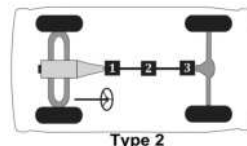
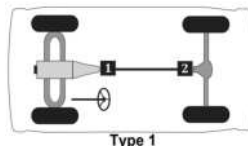

Passenger cars, light & medium trucks

Dodge Truck 3/4 ton -- (Cont.)

MFG./YEAR	MODEL & LOCATION	PART NO.	MFG./YEAR	MODEL & LOCATION	PART NO.
Drive Shaft (4 W/D)			Drive Shaft (4 W/D) (Cont.)		
U-Joint			U-Joint (Cont.)		
2010	R2500 w/ Gas Eng. & 2 Joint Shaft:		2010	R2500 w/ Diesel Eng. & 3 Joint Shaft:	
	[Type 26]			[Type 27]	
U-Joint (Fr. Shaft; Frt.)	●	UJ331	U-Joint (Fr. Shaft; Frt.)	●	UJ331
Brute Force Greaseable		UJ232	Brute Force Greaseable		UJ232
Brute Force Non Greaseable		UJ231	Brute Force Non Greaseable		UJ231
(For Aluminum Drive Shaft)		UJ331C	(For Aluminum Drive Shaft)		UJ331C
U-Joint (Fr. Shaft; Rr.)	⊗	[2] UJ331	U-Joint (Fr. Shaft; Rr.)	⊗	[2] UJ331
Brute Force Greaseable		UJ232	Brute Force Greaseable		UJ232
Brute Force Non Greaseable		UJ231	Brute Force Non Greaseable		UJ231
(For Aluminum Drive Shaft)		UJ331C	(For Aluminum Drive Shaft)		UJ331C
U-Joint (Rr. Shaft; Frt.)	⊕	UJ330A	U-Joint (Rr. Shaft; Frt.)	⊕	UJ351A
Brute Force Greaseable		UJ295A	Brute Force Non Greaseable		UJ351ABF
U-Joint (Rr. Shaft; Rr.)	⊕	UJ330A	U-Joint (Rr. Shaft; Ctr.)	⊕	UJ351A
Brute Force Greaseable		UJ295A	Brute Force Non Greaseable		UJ351ABF
U-Joint (Wheel Joint)	⊕	[2] UJ479	U-Joint (Rr. Shaft; Rr.)	⊕	UJ351A
Centering Ball Kit		UJ617	Brute Force Non Greaseable		UJ351ABF
H Yoke		UJ650	U-Joint (Wheel Joint)	⊕	[2] UJ479
2010	R2500 w/ Gas Eng. & 3 Joint Shaft:		2009-2008 R2500 w/ Gas Eng., Frt. Shaft Outer		
	[Type 27]		Lock Rings & 3 Joint Rr. Shaft: [Type		
U-Joint (Fr. Shaft; Frt.)	●	UJ331	27]		
Brute Force Greaseable		UJ232	U-Joint (Fr. Shaft; Frt.)	●	UJ331
Brute Force Non Greaseable		UJ231	Brute Force Greaseable		UJ232
(For Aluminum Drive Shaft)		UJ331C	Brute Force Non Greaseable		UJ231
U-Joint (Fr. Shaft; Rr.)	⊗	[2] UJ331	(For Aluminum Drive Shaft)		UJ331C
Brute Force Greaseable		UJ232	U-Joint (Fr. Shaft; Rr.)	⊗	[2] UJ331
Brute Force Non Greaseable		UJ231	Brute Force Greaseable		UJ232
(For Aluminum Drive Shaft)		UJ331C	Brute Force Non Greaseable		UJ231
U-Joint (Rr. Shaft; Frt.)	⊕	UJ330A	(For Aluminum Drive Shaft)		UJ331C
Brute Force Greaseable		UJ295A	U-Joint (Rr. Shaft; Frt.)	⊕	UJ330A
U-Joint (Rr. Shaft; Ctr.)	⊕	UJ330A	Brute Force Greaseable		UJ295A
Brute Force Greaseable		UJ295A	U-Joint (Rr. Shaft; Ctr.)	⊕	UJ330A
U-Joint (Rr. Shaft; Rr.)	⊕	UJ330A	Brute Force Greaseable		UJ295A
Brute Force Greaseable		UJ295A	U-Joint (Rr. Shaft; Rr.)	⊕	UJ330A
U-Joint (Wheel Joint)	⊕	[2] UJ479	Brute Force Greaseable		UJ295A
Centering Ball Kit		UJ617	U-Joint (Wheel Joint)	⊕	[2] UJ464
H Yoke		UJ650	Centering Ball Kit		UJ617
2010	R2500 w/ Diesel Eng. & 2 Joint Shaft:		H Yoke		UJ650
	[Type 26]				(Continued)
U-Joint (Fr. Shaft; Frt.)	●	UJ331			
Brute Force Greaseable		UJ232			
Brute Force Non Greaseable		UJ231			
(For Aluminum Drive Shaft)		UJ331C			
U-Joint (Fr. Shaft; Rr.)	⊗	[2] UJ331			
Brute Force Greaseable		UJ232			
Brute Force Non Greaseable		UJ231			
(For Aluminum Drive Shaft)		UJ331C			
U-Joint (Rr. Shaft; Frt.)	⊕	UJ351A			
Brute Force Non Greaseable		UJ351ABF			
U-Joint (Rr. Shaft; Rr.)	⊕	UJ351A			
Brute Force Non Greaseable		UJ351ABF			
U-Joint (Wheel Joint)	⊕	[2] UJ479			
Centering Ball Kit		UJ617			
H Yoke		UJ650			

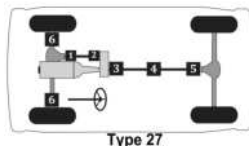
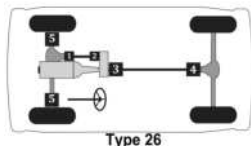

MFG./YEAR	MODEL & LOCATION	PART NO.	MFG./YEAR	MODEL & LOCATION	PART NO.
Drive Shaft (4 W/D) (Cont.)			Drive Shaft (4 W/D) (Cont.)		
U-Joint (Cont.)			U-Joint (Cont.)		
2009-2008 R2500 w/ Gas Eng., Frt. Shaft Inner			2009-2008 R2500 w/ Diesel Eng., Frt. Shaft Outer		
Lock Rings & 2 Joint Rr. Shaft: [Type 26]			Lock Rings & 3 Joint Rr. Shaft: [Type 27]		
U-Joint (Frt. Shaft; Frt.)①		UJ534G	U-Joint (Frt. Shaft; Frt.)①		UJ331
Brute Force Greaseable		UJ235	Brute Force Greaseable		UJ232
Brute Force Non Greaseable		UJ234	Brute Force Non Greaseable		UJ231
U-Joint (Frt. Shaft; Rr.)②	[2]	UJ534G	(For Aluminum Drive Shaft)		UJ331C
Brute Force Greaseable		UJ235	U-Joint (Frt. Shaft; Rr.)②	[2]	UJ331
Brute Force Non Greaseable		UJ234	Brute Force Greaseable		UJ232
U-Joint (Rr. Shaft; Frt.)③		UJ330A	Brute Force Non Greaseable		UJ231
Brute Force Greaseable		UJ295A	(For Aluminum Drive Shaft)		UJ331C
U-Joint (Rr. Shaft; Rr.)④		UJ330A	U-Joint (Rr. Shaft; Frt.)③		UJ351A
Brute Force Greaseable		UJ295A	Brute Force Non Greaseable		UJ351ABF
U-Joint (Wheel Joint)⑤	[2]	UJ464	U-Joint (Rr. Shaft; Ctr.)④		UJ351A
Ball Seat Repair Kit		UJ606	Brute Force Non Greaseable		UJ351ABF
H Yoke		UJ646	U-Joint (Rr. Shaft; Rr.)⑤		UJ351A
2009-2008 R2500 w/ Gas Eng., Frt. Shaft Inner			2009-2008 R2500 w/ Diesel Eng., Frt. Shaft Inner		
Lock Rings & 3 Joint Rr. Shaft: [Type 27]			Lock Rings & 2 Joint Rr. Shaft: [Type 26]		
U-Joint (Frt. Shaft; Frt.)①		UJ534G	U-Joint (Frt. Shaft; Frt.)①		UJ534G
Brute Force Greaseable		UJ235	Brute Force Greaseable		UJ235
Brute Force Non Greaseable		UJ234	Brute Force Non Greaseable		UJ234
U-Joint (Frt. Shaft; Rr.)②	[2]	UJ534G	U-Joint (Frt. Shaft; Rr.)②	[2]	UJ534G
Brute Force Greaseable		UJ235	Brute Force Greaseable		UJ235
Brute Force Non Greaseable		UJ234	Brute Force Non Greaseable		UJ234
U-Joint (Rr. Shaft; Frt.)③		UJ330A	U-Joint (Rr. Shaft; Rr.)⑤		UJ351A
Brute Force Greaseable		UJ295A	Brute Force Non Greaseable		UJ351ABF
U-Joint (Rr. Shaft; Ctr.)④		UJ330A	U-Joint (Rr. Shaft; Rr.)⑥		UJ351A
Brute Force Greaseable		UJ295A	Brute Force Non Greaseable		UJ351ABF
U-Joint (Rr. Shaft; Rr.)⑤		UJ330A	U-Joint (Rr. Shaft; Frt.)③		UJ351A
Brute Force Greaseable		UJ295A	Brute Force Non Greaseable		UJ351ABF
U-Joint (Wheel Joint)⑥	[2]	UJ464	U-Joint (Rr. Shaft; Rr.)④		UJ351A
Ball Seat Repair Kit		UJ606	Brute Force Non Greaseable		UJ351ABF
H Yoke		UJ646	U-Joint (Wheel Joint)⑥	[2]	UJ464
2009-2008 R2500 w/ Gas Eng., Frt. Shaft Outer			Ball Seat Repair Kit		
Lock Rings & 2 Joint Rr. Shaft: [Type 26]			UJ606		
U-Joint (Frt. Shaft; Frt.)①		UJ331	H Yoke		UJ650
Brute Force Greaseable		UJ232			
Brute Force Non Greaseable		UJ231			
(For Aluminum Drive Shaft)		UJ331C			
U-Joint (Frt. Shaft; Rr.)②	[2]	UJ331			
Brute Force Greaseable		UJ232			
Brute Force Non Greaseable		UJ231			
(For Aluminum Drive Shaft)		UJ331C			
U-Joint (Rr. Shaft; Frt.)③		UJ330A			
Brute Force Greaseable		UJ295A			
U-Joint (Rr. Shaft; Rr.)④		UJ330A			
Brute Force Greaseable		UJ295A			
U-Joint (Wheel Joint)⑤	[2]	UJ464			
Centering Ball Kit		UJ617			
H Yoke		UJ650			

(Continued)

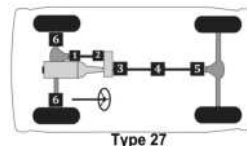
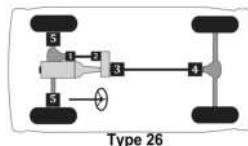

Passenger cars, light & medium trucks

Dodge Truck 3/4 ton -- (Cont.)

MFG./YEAR	MODEL & LOCATION	PART NO.	MFG./YEAR	MODEL & LOCATION	PART NO.
Drive Shaft (4 W/D) (Cont.)			Drive Shaft (4 W/D) (Cont.)		
U-Joint (Cont.)			U-Joint (Cont.)		
2009-2008 R2500 w/ Diesel Eng., Frt. Shaft Inner Lock Rings & 3 Joint Rr. Shaft: [Type 27]			2007 R2500 w/ Diesel Eng., 4 Spd. Auto. Trans. & 2 Joint Rr. Shaft: [Type 26]		
U-Joint (Frt. Shaft; Frt.)Ⓚ		UJ534G	U-Joint (Frt. Shaft; Frt.)Ⓚ		UJ534G
Brute Force Greaseable		UJ235	Brute Force Greaseable		UJ235
Brute Force Non Greaseable		UJ234	Brute Force Non Greaseable		UJ234
U-Joint (Frt. Shaft; Rr.)Ⓚ	[2]	UJ534G	U-Joint (Frt. Shaft; Rr.)Ⓚ	[2]	UJ331
Brute Force Greaseable		UJ235	Brute Force Greaseable		UJ232
Brute Force Non Greaseable		UJ234	Brute Force Non Greaseable		UJ231
U-Joint (Rr. Shaft; Frt.)Ⓚ		UJ351A	(For Aluminum Drive Shaft)		UJ331C
Brute Force Non Greaseable		UJ351ABF	U-Joint (Rr. Shaft; Frt.)Ⓚ		UJ330A
U-Joint (Rr. Shaft; Ctr.)Ⓚ		UJ351A	Brute Force Greaseable		UJ295A
Brute Force Non Greaseable		UJ351ABF	U-Joint (Rr. Shaft; Rr.)Ⓚ		UJ330A
U-Joint (Rr. Shaft; Rr.)Ⓚ		UJ351A	Brute Force Greaseable		UJ295A
Brute Force Non Greaseable		UJ351ABF	U-Joint (Wheel Joint)Ⓚ	[2]	UJ464
U-Joint (Wheel Joint)Ⓚ	[2]	UJ464	Centering Ball Kit		UJ617
Ball Seat Repair Kit		UJ606	H Yoke		UJ650
H Yoke		UJ646	2007 R2500 w/ Diesel Eng., 2 Joint Rr. Shaft Exc. 4 Spd. Auto. Trans.: [Type 26]		
2009-2008 R2500 w/ Diesel Eng., Frt. Shaft Outer Lock Rings & 2 Joint Rr. Shaft: [Type 26]			U-Joint (Frt. Shaft; Frt.)Ⓚ		UJ534G
U-Joint (Frt. Shaft; Frt.)Ⓚ		UJ331	Brute Force Greaseable		UJ235
Brute Force Greaseable		UJ232	Brute Force Non Greaseable		UJ234
Brute Force Non Greaseable		UJ231	U-Joint (Frt. Shaft; Rr.)Ⓚ	[2]	UJ331
(For Aluminum Drive Shaft)		UJ331C	Brute Force Greaseable		UJ232
U-Joint (Frt. Shaft; Rr.)Ⓚ	[2]	UJ331	Brute Force Non Greaseable		UJ231
Brute Force Greaseable		UJ232	(For Aluminum Drive Shaft)		UJ331C
Brute Force Non Greaseable		UJ231	U-Joint (Rr. Shaft; Frt.)Ⓚ		UJ351A
(For Aluminum Drive Shaft)		UJ331C	Brute Force Non Greaseable		UJ351ABF
U-Joint (Rr. Shaft; Frt.)Ⓚ		UJ351A	U-Joint (Rr. Shaft; Rr.)Ⓚ		UJ351A
Brute Force Non Greaseable		UJ351ABF	Brute Force Non Greaseable		UJ351ABF
U-Joint (Rr. Shaft; Rr.)Ⓚ		UJ351A	U-Joint (Wheel Joint)Ⓚ	[2]	UJ464
Brute Force Non Greaseable		UJ351ABF	Centering Ball Kit		UJ617
U-Joint (Wheel Joint)Ⓚ	[2]	UJ464	H Yoke		UJ650
Centering Ball Kit		UJ617	2007 R2500 w/ Diesel Eng., 4 Spd. Auto. Trans. & 3 Joint Rr. Shaft: [Type 27]		
H Yoke		UJ650	U-Joint (Frt. Shaft; Frt.)Ⓚ		UJ534G
			Brute Force Greaseable		UJ235
			Brute Force Non Greaseable		UJ234
			U-Joint (Frt. Shaft; Rr.)Ⓚ	[2]	UJ331
			Brute Force Greaseable		UJ232
			Brute Force Non Greaseable		UJ231
			(For Aluminum Drive Shaft)		UJ331C
			U-Joint (Rr. Shaft; Frt.)Ⓚ		UJ330A
			Brute Force Greaseable		UJ295A
			U-Joint (Rr. Shaft; Ctr.)Ⓚ		UJ330A
			Brute Force Greaseable		UJ295A
			U-Joint (Rr. Shaft; Rr.)Ⓚ		UJ330A
			Brute Force Greaseable		UJ295A
			U-Joint (Wheel Joint)Ⓚ	[2]	UJ464
			Centering Ball Kit		UJ617
			H Yoke		UJ650

(Continued)

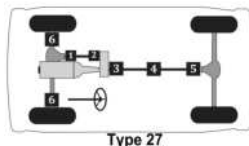
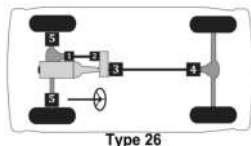

250 ▲ For Use w/ 1.063" Bearing Cap Application. Ⓚ For Use w/ 1.188" Bearing Cap Application. ◇ For Use w/ Inner Lock Ring Application on Half Shaft. □ For Use w/ Outer Lock Ring Application on Half Shaft.



MFG./YEAR	MODEL & LOCATION	PART NO.	MFG./YEAR	MODEL & LOCATION	PART NO.
Drive Shaft (4 W/D) (Cont.)			Drive Shaft (4 W/D) (Cont.)		
U-Joint (Cont.)			U-Joint (Cont.)		
2007	R2500 w/ Diesel Eng., 3 Joint Rr. Shaft Exc. 4 Spd. Auto. Trans.: [Type 27]		2006-2005	R2500 w/ Diesel Eng., Auto. Trans. & 3 Joint Rr. Shaft: [Type 27]	
	U-Joint (Frnt. Shaft; Frnt.) ^①	UJ534G		U-Joint (Frnt. Shaft; Frnt.) ^①	UJ534G
	Brute Force Greaseable	UJ235		Brute Force Greaseable	UJ235
	Brute Force Non Greaseable	UJ234		Brute Force Non Greaseable	UJ234
	U-Joint (Frnt. Shaft; Rr.) ^②	[2] UJ331		U-Joint (Frnt. Shaft; Rr.) ^②	[2] UJ331A
	Brute Force Greaseable	UJ232		Brute Force Greaseable	UJ232A
	Brute Force Non Greaseable	UJ231		U-Joint (Rr. Shaft; Frnt.) ^③	UJ330A
	(For Aluminum Drive Shaft)	UJ331C		Brute Force Greaseable	UJ295A
	U-Joint (Rr. Shaft; Frnt.) ^③	UJ351A		U-Joint (Rr. Shaft; Ctr.) ^④	UJ330A
	Brute Force Non Greaseable	UJ351ABF		Brute Force Greaseable	UJ295A
	U-Joint (Rr. Shaft; Ctr.) ^④	UJ351A		U-Joint (Rr. Shaft; Rr.) ^⑤	UJ330A
	Brute Force Non Greaseable	UJ351ABF		Brute Force Greaseable	UJ295A
	U-Joint (Rr. Shaft; Rr.) ^⑤	UJ351A		U-Joint (Wheel Joint) ^⑥	[2] UJ464
	Brute Force Non Greaseable	UJ351ABF		Centering Ball Kit	UJ617
	U-Joint (Wheel Joint) ^⑥	[2] UJ464		H Yoke	UJ650
	Centering Ball Kit	UJ617		2006-2005 R2500 w/ Diesel Eng., Auto. Trans. & 2	
	H Yoke	UJ650		Joint Rr. Shaft: [Type 26]	
	2007-2005 R2500 w/ Gas Eng. & 2 Joint Shaft:			U-Joint (Frnt. Shaft; Frnt.) ^①	UJ534G
	[Type 26]			Brute Force Greaseable	UJ235
	U-Joint (Frnt. Shaft; Frnt.) ^①	UJ534G		Brute Force Non Greaseable	UJ234
	Brute Force Greaseable	UJ235		U-Joint (Frnt. Shaft; Rr.) ^②	[2] UJ331A
	Brute Force Non Greaseable	UJ234		Brute Force Greaseable	UJ232A
	U-Joint (Frnt. Shaft; Rr.) ^②	[2] UJ331		U-Joint (Rr. Shaft; Frnt.) ^③	UJ330A
	Brute Force Greaseable	UJ232		Brute Force Greaseable	UJ295A
	Brute Force Non Greaseable	UJ231		U-Joint (Rr. Shaft; Rr.) ^④	UJ330A
	(For Aluminum Drive Shaft)	UJ331C		Brute Force Greaseable	UJ295A
	U-Joint (Rr. Shaft; Frnt.) ^③	UJ330A		U-Joint (Wheel Joint) ^⑥	[2] UJ464
	Brute Force Greaseable	UJ295A		Centering Ball Kit	UJ617
	U-Joint (Rr. Shaft; Rr.) ^④	UJ330A		H Yoke	UJ650
	Brute Force Greaseable	UJ295A		2006-2005 R2500 w/ Diesel Eng., Man. Trans. & 2	
	U-Joint (Wheel Joint) ^⑥	[2] UJ464		Joint Rr. Shaft: [Type 26]	
	Centering Ball Kit	UJ617		U-Joint (Frnt. Shaft; Frnt.) ^①	UJ534G
	H Yoke	UJ650		Brute Force Greaseable	UJ235
	2007-2005 R2500 w/ Gas Eng. & 3 Joint Shaft:			Brute Force Non Greaseable	UJ234
	[Type 27]			U-Joint (Frnt. Shaft; Rr.) ^②	[2] UJ331A
	U-Joint (Frnt. Shaft; Frnt.) ^①	UJ534G		Brute Force Greaseable	UJ232A
	Brute Force Greaseable	UJ235		U-Joint (Rr. Shaft; Frnt.) ^③	UJ351A
	Brute Force Non Greaseable	UJ234		Brute Force Non Greaseable	UJ351ABF
	U-Joint (Frnt. Shaft; Rr.) ^②	[2] UJ331		U-Joint (Rr. Shaft; Rr.) ^④	UJ351A
	Brute Force Greaseable	UJ232		Brute Force Non Greaseable	UJ351ABF
	Brute Force Non Greaseable	UJ231		U-Joint (Wheel Joint) ^⑥	[2] UJ464
	(For Aluminum Drive Shaft)	UJ331C		Centering Ball Kit	UJ617
	U-Joint (Rr. Shaft; Frnt.) ^③	UJ330A		H Yoke	UJ650
	Brute Force Greaseable	UJ295A			
	U-Joint (Rr. Shaft; Ctr.) ^④	UJ330A			
	Brute Force Greaseable	UJ295A			
	U-Joint (Rr. Shaft; Rr.) ^⑤	UJ330A			
	Brute Force Greaseable	UJ295A			
	U-Joint (Wheel Joint) ^⑥	[2] UJ464			
	Centering Ball Kit	UJ617			
	H Yoke	UJ650			

(Continued)

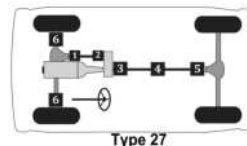
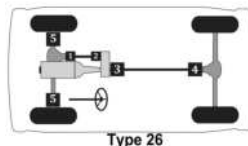

Passenger cars, light & medium trucks

Dodge Truck 3/4 ton -- (Cont.)

MFG./YEAR	MODEL & LOCATION	PART NO.	MFG./YEAR	MODEL & LOCATION	PART NO.
Drive Shaft (4 W/D) (Cont.)			Drive Shaft (4 W/D) (Cont.)		
U-Joint (Cont.)			U-Joint (Cont.)		
2006-2005 R2500 w/ Diesel Eng., Man. Trans. & 3 Joint Rr. Shaft: [Type 27]			2004 R2500 w/ 3 Joint Rr. Shaft. Exc. 6 Spd. Man. Trans.: [Type 27]		
U-Joint (Fr. Shaft; Frt.)⊙		UJ534G	U-Joint (Fr. Shaft; Frt.)⊙		UJ534G
Brute Force Greaseable		UJ235	Brute Force Greaseable		UJ235
Brute Force Non Greaseable		UJ234	Brute Force Non Greaseable		UJ234
U-Joint (Fr. Shaft; Rr.)⊙	[2]	UJ331A	U-Joint (Fr. Shaft; Rr.)⊙	[2]	UJ354
Brute Force Greaseable		UJ232A	Brute Force Greaseable		UJ270
U-Joint (Rr. Shaft; Frt.)⊙		UJ351A	Brute Force Non Greaseable		UJ254
Brute Force Non Greaseable		UJ351ABF	(For Aluminum Drive Shaft)		UJ354C
U-Joint (Rr. Shaft; Ctr.)⊙		UJ351A	U-Joint (Rr. Shaft; Frt.)⊙		UJ330A
Brute Force Non Greaseable		UJ351ABF	Brute Force Greaseable		UJ295A
U-Joint (Rr. Shaft; Rr.)⊙		UJ351A	U-Joint (Rr. Shaft; Ctr.)⊙		UJ330A
Brute Force Non Greaseable		UJ351ABF	Brute Force Greaseable		UJ295A
U-Joint (Wheel Joint)⊙	[2]	UJ464	U-Joint (Rr. Shaft; Rr.)⊙		UJ330A
Centering Ball Kit		UJ617	Brute Force Greaseable		UJ295A
H Yoke		UJ650	U-Joint (Wheel Joint)⊙	[2]	UJ464
2004 R2500 w/ 2 Joint Rr. Shaft. Exc. 6 Spd. Man. Trans.: [Type 26]			Centering Ball Kit		UJ617
U-Joint (Fr. Shaft; Frt.)⊙		UJ534G	Flange Yoke		UJ628C
Brute Force Greaseable		UJ235	H Yoke		UJ648
Brute Force Non Greaseable		UJ234	2004 R2500 w/ 6 Spd. Man. Trans. & 3 Joint Rr. Shaft: [Type 27]		
U-Joint (Fr. Shaft; Rr.)⊙	[2]	UJ354	U-Joint (Fr. Shaft; Frt.)⊙		UJ534G
Brute Force Greaseable		UJ270	Brute Force Greaseable		UJ235
Brute Force Non Greaseable		UJ254	Brute Force Non Greaseable		UJ234
(For Aluminum Drive Shaft)		UJ354C	U-Joint (Fr. Shaft; Rr.)⊙	[2]	UJ354
U-Joint (Rr. Shaft; Frt.)⊙		UJ330A	Brute Force Greaseable		UJ270
Brute Force Greaseable		UJ295A	Brute Force Non Greaseable		UJ254
U-Joint (Rr. Shaft; Rr.)⊙		UJ330A	(For Aluminum Drive Shaft)		UJ354C
Brute Force Greaseable		UJ295A	U-Joint (Rr. Shaft; Frt.)⊙		UJ351A
U-Joint (Wheel Joint)⊙	[2]	UJ464	Brute Force Non Greaseable		UJ351ABF
Centering Ball Kit		UJ617	U-Joint (Rr. Shaft; Ctr.)⊙		UJ351A
Flange Yoke		UJ628C	Brute Force Non Greaseable		UJ351ABF
H Yoke		UJ648	U-Joint (Rr. Shaft; Rr.)⊙		UJ351A
			Brute Force Non Greaseable		UJ351ABF
			U-Joint (Wheel Joint)⊙	[2]	UJ464
			Centering Ball Kit		UJ617
			Flange Yoke		UJ628C
			H Yoke		UJ648

(Continued)

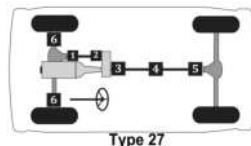
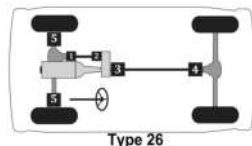

252 ▲ For Use w/ 1.063" Bearing Cap Application. ⊙ For Use w/ 1.188" Bearing Cap Application. ◇ For Use w/ Inner Lock Ring Application on Half Shaft. □ For Use w/ Outer Lock Ring Application on Half Shaft.

MFG./YEAR	MODEL & LOCATION	PART NO.	MFG./YEAR	MODEL & LOCATION	PART NO.
Drive Shaft (4 W/D) (Cont.)			Drive Shaft (4 W/D) (Cont.)		
U-Joint (Cont.)			U-Joint (Cont.)		
2004	R2500 w/ 6 Spd. Man. Trans. & 2 Joint Rr. Shaft: [Type 26]		2003	R2500 w/ 2 Joint Rr. Shaft. Exc. 6 Spd. Man. Trans.: [Type 26]	
	U-Joint (Frnt. Shaft; Frt.) ^①	UJ534G		U-Joint (Frnt. Shaft; Frt.) ^①	UJ534G
	Brute Force Greaseable	UJ235		Brute Force Greaseable	UJ235
	Brute Force Non Greaseable	UJ234		Brute Force Non Greaseable	UJ234
	U-Joint (Frnt. Shaft; Rr.) ^②	[2] UJ354		U-Joint (Frnt. Shaft; Rr.) ^②	[2] UJ354
	Brute Force Greaseable	UJ270		Brute Force Greaseable	UJ270
	Brute Force Non Greaseable	UJ254		Brute Force Non Greaseable	UJ254
	(For Aluminum Drive Shaft)	UJ354C		(For Aluminum Drive Shaft)	UJ354C
	U-Joint (Rr. Shaft; Frt.) ^③	UJ351A		U-Joint (Rr. Shaft; Frt.) ^③	UJ330A
	Brute Force Non Greaseable	UJ351ABF		Brute Force Greaseable	UJ295A
	U-Joint (Rr. Shaft; Rr.) ^④	UJ351A		U-Joint (Rr. Shaft; Rr.) ^④	UJ330A
	Brute Force Non Greaseable	UJ351ABF		Brute Force Greaseable	UJ295A
	U-Joint (Wheel Joint) ^⑤	[2] UJ464		U-Joint (Wheel Joint) ^⑤	[2] UJ464
	Centering Ball Kit	UJ617		Centering Ball Kit	UJ617
	Flange Yoke	UJ628C		Flange Yoke	UJ628C
	H Yoke	UJ648		H Yoke	UJ648
2003	R2500 w/ 6 Spd. Man. Trans.: [Type 27]		2003	R2500 w/ 3 Joint Rr. Shaft. Exc. 6 Spd. Man. Trans.: [Type 27]	
	U-Joint (Frnt. Shaft; Frt.) ^①	UJ534G		U-Joint (Frnt. Shaft; Frt.) ^①	UJ534G
	Brute Force Greaseable	UJ235		Brute Force Greaseable	UJ235
	Brute Force Non Greaseable	UJ234		Brute Force Non Greaseable	UJ234
	U-Joint (Frnt. Shaft; Rr.) ^②	[2] UJ354		U-Joint (Frnt. Shaft; Rr.) ^②	[2] UJ354
	Brute Force Greaseable	UJ270		Brute Force Greaseable	UJ270
	Brute Force Non Greaseable	UJ254		Brute Force Non Greaseable	UJ254
	(For Aluminum Drive Shaft)	UJ354C		(For Aluminum Drive Shaft)	UJ354C
	U-Joint (Rr. Shaft; Frt.) ^③	UJ351A		U-Joint (Rr. Shaft; Frt.) ^③	UJ330A
	Brute Force Non Greaseable	UJ351ABF		Brute Force Greaseable	UJ295A
	U-Joint (Rr. Shaft; Ctr.) ^④	UJ351A		U-Joint (Rr. Shaft; Ctr.) ^④	UJ330A
	Brute Force Non Greaseable	UJ351ABF		Brute Force Greaseable	UJ295A
	U-Joint (Rr. Shaft; Rr.) ^⑤	UJ351A		U-Joint (Rr. Shaft; Rr.) ^⑤	UJ330A
	Brute Force Non Greaseable	UJ351ABF		Brute Force Greaseable	UJ295A
	U-Joint (Wheel Joint) ^⑥	[2] UJ464		U-Joint (Wheel Joint) ^⑥	[2] UJ464
	Centering Ball Kit	UJ617		Centering Ball Kit	UJ617
	Flange Yoke	UJ628C		Flange Yoke	UJ628C
	H Yoke	UJ648		H Yoke	UJ648

(Continued)

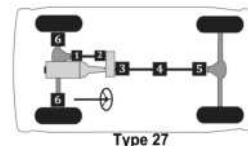
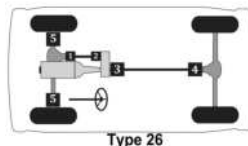

Passenger cars, light & medium trucks

Dodge Truck 3/4 ton -- (Cont.)

MFG./YEAR	MODEL & LOCATION	PART NO.	MFG./YEAR	MODEL & LOCATION	PART NO.
Drive Shaft (4 W/D) (Cont.)			Drive Shaft (4 W/D) (Cont.)		
U-Joint (Cont.)			U-Joint (Cont.)		
2002-2000 R2500 w/ 2 Joint Shaft: [Type 26]			1999-1997 R2500 w/ Frt. Shaft Outer Lock Rings, 1.375" Dia. Whl. Joint Brg. Caps, 2 Joint Rr. Shaft & Inner Lock Rings: [Type 26]		
U-Joint (Frt. Shaft; Frt.)Ⓚ		UJ354	U-Joint (Frt. Shaft; Frt.)Ⓚ		UJ458
Brute Force Greaseable		UJ270	(For Aluminum Drive Shaft)		UJ458C
Brute Force Non Greaseable		UJ254	Brute Force Non Greaseable		UJ458BF
(For Aluminum Drive Shaft)		UJ354C	U-Joint (Frt. Shaft; Rr.)Ⓛ	[2]	UJ354
U-Joint (Frt. Shaft; Rr.)Ⓛ	[2]	UJ354	Brute Force Greaseable		UJ270
Brute Force Greaseable		UJ270	Brute Force Non Greaseable		UJ254
Brute Force Non Greaseable		UJ254	(For Aluminum Drive Shaft)		UJ354C
(For Aluminum Drive Shaft)		UJ354C	U-Joint (Rr. Shaft; Frt.)Ⓚ		UJ330
U-Joint (Rr. Shaft; Frt.)Ⓚ		UJ330	Brute Force Greaseable		UJ295
Brute Force Greaseable		UJ295	(For Aluminum Drive Shaft)		UJ330C
(For Aluminum Drive Shaft)		UJ330C	U-Joint (Rr. Shaft; Rr.)Ⓛ		UJ330
U-Joint (Rr. Shaft; Rr.)Ⓛ		UJ330	Brute Force Greaseable		UJ295
Brute Force Greaseable		UJ295	(For Aluminum Drive Shaft)		UJ330C
(For Aluminum Drive Shaft)		UJ330C	U-Joint (Rr. Shaft; Rr.)Ⓛ		UJ330
Clamp Kit (Rr. Shaft; Rr.)		UJ331-10	Brute Force Greaseable		UJ295
U-Joint (Wheel Joint)Ⓚ	[2]	UJ374	(For Aluminum Drive Shaft)		UJ330C
Brute Force Non Greaseable		UJ374BF	Clamp Kit (Rr. Shaft; Rr.)		UJ331-10
Centering Ball Kit		UJ617	U-Joint (Wheel Joint)Ⓚ	[2]	UJ374
Flange Yoke		UJ628C	Brute Force Non Greaseable		UJ374BF
H Yoke		UJ648	Centering Ball Kit		UJ617
2002-2000 R2500 w/ 3 Joint Shaft: [Type 27]			Flange Yoke		UJ628C
U-Joint (Frt. Shaft; Frt.)Ⓚ		UJ354	H Yoke		UJ648
Brute Force Greaseable		UJ270	1999-1997 R2500 w/ Frt. Shaft Inner Lock Rings, 1.188" Dia. Whl. Joint Brg. Caps & 3 Joint Rr. Shaft: [Type 27]		
Brute Force Non Greaseable		UJ254	U-Joint (Frt. Shaft; Frt.)Ⓚ		UJ316
(For Aluminum Drive Shaft)		UJ354C	Brute Force Greaseable		UJ248
U-Joint (Frt. Shaft; Rr.)Ⓛ	[2]	UJ354	Clamp Kit (Frt. Shaft; Frt.)		UJ316-10
Brute Force Greaseable		UJ270	U-Joint (Frt. Shaft; Rr.)Ⓛ	[2]	UJ354
Brute Force Non Greaseable		UJ254	Brute Force Greaseable		UJ270
(For Aluminum Drive Shaft)		UJ354C	Brute Force Non Greaseable		UJ254
U-Joint (Rr. Shaft; Frt.)Ⓚ		UJ330	(For Aluminum Drive Shaft)		UJ354C
Brute Force Greaseable		UJ295	U-Joint (Rr. Shaft; Frt.)Ⓚ		UJ330
(For Aluminum Drive Shaft)		UJ330C	Brute Force Greaseable		UJ295
U-Joint (Rr. Shaft; Ctr.)Ⓚ		UJ330	(For Aluminum Drive Shaft)		UJ330C
Brute Force Greaseable		UJ295	U-Joint (Rr. Shaft; Ctr.)Ⓚ		UJ330
(For Aluminum Drive Shaft)		UJ330C	Brute Force Greaseable		UJ295
U-Joint (Rr. Shaft; Rr.)Ⓛ		UJ330	(For Aluminum Drive Shaft)		UJ330C
Brute Force Greaseable		UJ295	U-Joint (Rr. Shaft; Rr.)Ⓛ		UJ330
(For Aluminum Drive Shaft)		UJ330C	Brute Force Greaseable		UJ295
Clamp Kit (Rr. Shaft; Rr.)		UJ331-10	(For Aluminum Drive Shaft)		UJ330C
U-Joint (Wheel Joint)Ⓚ	[2]	UJ374	U-Joint (Rr. Shaft; Rr.)Ⓛ		UJ330
Brute Force Non Greaseable		UJ374BF	Brute Force Greaseable		UJ295
Centering Ball Kit		UJ617	(For Aluminum Drive Shaft)		UJ330C
Flange Yoke		UJ628C	Clamp Kit (Rr. Shaft; Rr.)		UJ331-10
H Yoke		UJ648	U-Joint (Wheel Joint)Ⓚ	[2]	UJ371
			Brute Force Greaseable		UJ377
			Brute Force Non Greaseable		UJ371
			Centering Ball Kit		UJ617
			Flange Yoke		UJ628C
			H Yoke		UJ648

(Continued)

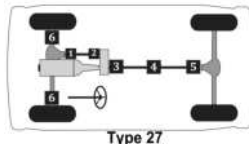
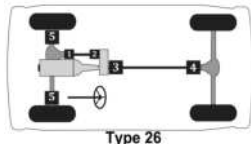

MFG./YEAR	MODEL & LOCATION	PART NO.	MFG./YEAR	MODEL & LOCATION	PART NO.
Drive Shaft (4 W/D) (Cont.)			Drive Shaft (4 W/D) (Cont.)		
U-Joint (Cont.)			U-Joint (Cont.)		
1999-1997 R2500 w/ Frt. Shaft Inner Lock Rings, 1.188" Dia. Whl. Joint Brg. Caps, 2 Joint Rr. Shaft & Inner Lock Rings: [Type 26]			1999-1997 R2500 w/ Frt. Shaft Inner Lock Rings, 1.375" Dia. Whl. Joint Brg. Caps & 3 Joint Rr. Shaft: [Type 27]		
U-Joint (Frt. Shaft; Frt.) ^①		UJ316	U-Joint (Frt. Shaft; Frt.) ^①		UJ316
Brute Force Greaseable		UJ248	Brute Force Greaseable		UJ248
Clamp Kit (Frt. Shaft; Frt.)		UJ316-10	Clamp Kit (Frt. Shaft; Frt.)		UJ316-10
U-Joint (Frt. Shaft; Rr.) ^②	[2]	UJ354	U-Joint (Frt. Shaft; Rr.) ^②	[2]	UJ354
Brute Force Greaseable		UJ270	Brute Force Greaseable		UJ270
Brute Force Non Greaseable		UJ254	Brute Force Non Greaseable		UJ254
(For Aluminum Drive Shaft)		UJ354C	(For Aluminum Drive Shaft)		UJ354C
U-Joint (Rr. Shaft; Frt.) ^③		UJ316	U-Joint (Rr. Shaft; Frt.) ^③		UJ316
Brute Force Greaseable		UJ248	Brute Force Greaseable		UJ248
Clamp Kit (Rr. Shaft; Frt.)		UJ316-10	Clamp Kit (Rr. Shaft; Frt.)		UJ316-10
U-Joint (Rr. Shaft; Rr.) ^④		UJ316	U-Joint (Rr. Shaft; Rr.) ^④		UJ316
Brute Force Greaseable		UJ248	Brute Force Greaseable		UJ248
Clamp Kit (Rr. Shaft; Rr.)		UJ316-10	Clamp Kit (Rr. Shaft; Rr.)		UJ316-10
U-Joint (Wheel Joint) ^⑤	[2]	UJ371	U-Joint (Wheel Joint) ^⑤	[2]	UJ371
Brute Force Greaseable		UJ377	Brute Force Greaseable		UJ377
Brute Force Non Greaseable		UJ371	Brute Force Non Greaseable		UJ371
Centering Ball Kit		UJ617	Centering Ball Kit		UJ617
Flange Yoke		UJ628C	Flange Yoke		UJ628C
H Yoke		UJ648	H Yoke		UJ648
1999-1997 R2500 w/ Frt. Shaft Inner Lock Rings, 1.188" Dia. Whl. Joint Brg. Caps, 2 Joint Rr. Shaft & Outer Lock Rings: [Type 26]			1999-1997 R2500 w/ Frt. Shaft Inner Lock Rings, 1.375" Dia. Whl. Joint Brg. Caps, 2 Joint Rr. Shaft & Inner Lock Rings: [Type 26]		
U-Joint (Frt. Shaft; Frt.) ^①		UJ316	U-Joint (Frt. Shaft; Frt.) ^①		UJ316
Brute Force Greaseable		UJ248	Brute Force Greaseable		UJ248
Clamp Kit (Frt. Shaft; Frt.)		UJ316-10	Clamp Kit (Frt. Shaft; Frt.)		UJ316-10
U-Joint (Frt. Shaft; Rr.) ^②	[2]	UJ354	U-Joint (Frt. Shaft; Rr.) ^②	[2]	UJ354
Brute Force Greaseable		UJ270	Brute Force Greaseable		UJ270
Brute Force Non Greaseable		UJ254	Brute Force Non Greaseable		UJ254
(For Aluminum Drive Shaft)		UJ354C	(For Aluminum Drive Shaft)		UJ354C
U-Joint (Rr. Shaft; Frt.) ^③		UJ330	U-Joint (Rr. Shaft; Frt.) ^③		UJ330
Brute Force Greaseable		UJ295	Brute Force Greaseable		UJ295
(For Aluminum Drive Shaft)		UJ330C	(For Aluminum Drive Shaft)		UJ330C
U-Joint (Rr. Shaft; Rr.) ^④		UJ330	U-Joint (Rr. Shaft; Rr.) ^④		UJ330
Brute Force Greaseable		UJ295	Brute Force Greaseable		UJ295
(For Aluminum Drive Shaft)		UJ330C	(For Aluminum Drive Shaft)		UJ330C
Clamp Kit (Rr. Shaft; Rr.)		UJ331-10	Clamp Kit (Rr. Shaft; Rr.)		UJ331-10
U-Joint (Wheel Joint) ^⑤	[2]	UJ371	U-Joint (Wheel Joint) ^⑤	[2]	UJ371
Brute Force Greaseable		UJ377	Brute Force Greaseable		UJ377
Brute Force Non Greaseable		UJ371	Brute Force Non Greaseable		UJ371
Centering Ball Kit		UJ617	Centering Ball Kit		UJ617
Flange Yoke		UJ628C	Flange Yoke		UJ628C
H Yoke		UJ648	H Yoke		UJ648

(Continued)

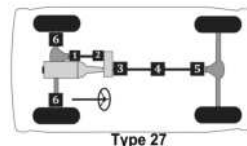
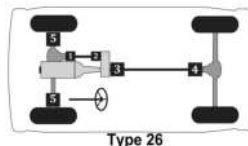

Passenger cars, light & medium trucks

Dodge Truck 3/4 ton -- (Cont.)

MFG./YEAR	MODEL & LOCATION	PART NO.	MFG./YEAR	MODEL & LOCATION	PART NO.
Drive Shaft (4 W/D) (Cont.)			Drive Shaft (4 W/D) (Cont.)		
U-Joint (Cont.)			U-Joint (Cont.)		
1999-1997 R2500 w/ Frt. Shaft Inner Lock Rings, 1.375" Dia. Whl. Joint Brg. Caps, 2 Joint Rr. Shaft & Outer Lock Rings: [Type 26]			1999-1997 R2500 w/ Frt. Shaft Outer Lock Rings, 1.188" Dia. Whl. Joint Brg. Caps, 2 Joint Rr. Shaft & Inner Lock Rings: [Type 26]		
U-Joint (Frt. Shaft; Frt.) [⊙]		UJ316	U-Joint (Frt. Shaft; Frt.) [⊙]		UJ458
Brute Force Greaseable		UJ248	(For Aluminum Drive Shaft)		UJ458C
Clamp Kit (Frt. Shaft; Frt.)		UJ316-10	Brute Force Non Greaseable		UJ458BF
U-Joint (Frt. Shaft; Rr.) [⊙]	[2]	UJ354	U-Joint (Frt. Shaft; Rr.) [⊙]	[2]	UJ354
Brute Force Greaseable		UJ270	Brute Force Greaseable		UJ270
Brute Force Non Greaseable		UJ254	Brute Force Non Greaseable		UJ254
(For Aluminum Drive Shaft)		UJ354C	(For Aluminum Drive Shaft)		UJ354C
U-Joint (Rr. Shaft; Frt.) [⊙]		UJ330	U-Joint (Rr. Shaft; Frt.) [⊙]		UJ316
Brute Force Greaseable		UJ295	Brute Force Greaseable		UJ248
(For Aluminum Drive Shaft)		UJ330C	Clamp Kit (Rr. Shaft; Frt.)		UJ316-10
U-Joint (Rr. Shaft; Rr.) [⊙]		UJ330	U-Joint (Rr. Shaft; Rr.) [⊙]		UJ316
Brute Force Greaseable		UJ295	Brute Force Greaseable		UJ248
(For Aluminum Drive Shaft)		UJ330C	Clamp Kit (Rr. Shaft; Rr.)		UJ316-10
Clamp Kit (Rr. Shaft; Rr.)		UJ331-10	U-Joint (Wheel Joint) [⊙]	[2]	UJ371
U-Joint (Wheel Joint) [⊙]	[2]	UJ374	Brute Force Greaseable		UJ377
Brute Force Non Greaseable		UJ374BF	Brute Force Non Greaseable		UJ371
Centering Ball Kit		UJ617	Centering Ball Kit		UJ617
Flange Yoke		UJ628C	Flange Yoke		UJ628C
H Yoke		UJ648	H Yoke		UJ648
1999-1997 R2500 w/ Frt. Shaft Outer Lock Rings, 1.188" Dia. Whl. Joint Brg. Caps & 3 Joint Rr. Shaft: [Type 27]			1999-1997 R2500 w/ Frt. Shaft Outer Lock Rings, 1.188" Dia. Whl. Joint Brg. Caps, 2 Joint Rr. Shaft & Outer Lock Rings: [Type 26]		
U-Joint (Frt. Shaft; Frt.) [⊙]		UJ458	U-Joint (Frt. Shaft; Frt.) [⊙]		UJ458
(For Aluminum Drive Shaft)		UJ458C	(For Aluminum Drive Shaft)		UJ458C
Brute Force Non Greaseable		UJ458BF	Brute Force Non Greaseable		UJ458BF
U-Joint (Frt. Shaft; Rr.) [⊙]	[2]	UJ354	U-Joint (Frt. Shaft; Rr.) [⊙]	[2]	UJ354
Brute Force Greaseable		UJ270	Brute Force Greaseable		UJ270
Brute Force Non Greaseable		UJ254	Brute Force Non Greaseable		UJ254
(For Aluminum Drive Shaft)		UJ354C	(For Aluminum Drive Shaft)		UJ354C
U-Joint (Rr. Shaft; Frt.) [⊙]		UJ330	U-Joint (Rr. Shaft; Frt.) [⊙]		UJ330
Brute Force Greaseable		UJ295	Brute Force Greaseable		UJ295
(For Aluminum Drive Shaft)		UJ330C	(For Aluminum Drive Shaft)		UJ330C
U-Joint (Rr. Shaft; Ctr.) [⊙]		UJ330	U-Joint (Rr. Shaft; Rr.) [⊙]		UJ330
Brute Force Greaseable		UJ295	Brute Force Greaseable		UJ295
(For Aluminum Drive Shaft)		UJ330C	(For Aluminum Drive Shaft)		UJ330C
U-Joint (Rr. Shaft; Rr.) [⊙]		UJ330	Clamp Kit (Rr. Shaft; Rr.)		UJ331-10
Brute Force Greaseable		UJ295	U-Joint (Wheel Joint) [⊙]	[2]	UJ371
(For Aluminum Drive Shaft)		UJ330C	Brute Force Greaseable		UJ377
Clamp Kit (Rr. Shaft; Rr.)		UJ331-10	Brute Force Non Greaseable		UJ371
U-Joint (Wheel Joint) [⊙]	[2]	UJ371	Centering Ball Kit		UJ617
Brute Force Greaseable		UJ377	Flange Yoke		UJ628C
Brute Force Non Greaseable		UJ371	H Yoke		UJ648
Centering Ball Kit		UJ617			(Continued)
Flange Yoke		UJ628C			
H Yoke		UJ648			

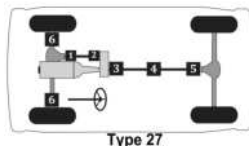
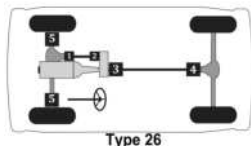

MFG./YEAR	MODEL & LOCATION	PART NO.	MFG./YEAR	MODEL & LOCATION	PART NO.
Drive Shaft (4 W/D) (Cont.)			Drive Shaft (4 W/D) (Cont.)		
U-Joint (Cont.)			U-Joint (Cont.)		
1999-1997 R2500 w/ Frt. Shaft Outer Lock Rings, 1.375" Dia. Whl. Joint Brg. Caps & 3 Joint Rr. Shaft: [Type 27]			1996-1994 R2500 w/ 5.2L, 5.9L Gas Eng. & 1.188" Dia. Whl. Joint Brg. Caps: [Type 26]		
U-Joint (Frt. Shaft; Frt.)①		UJ458	U-Joint (Frt. Shaft; Frt.)①		UJ316
(For Aluminum Drive Shaft)		UJ458C	Brute Force Greaseable		UJ248
Brute Force Non Greaseable		UJ458BF	U-Joint (Frt. Shaft; Rr.)②	[2]	UJ354
U-Joint (Frt. Shaft; Rr.)②	[2]	UJ354	Brute Force Greaseable		UJ270
Brute Force Greaseable		UJ270	Brute Force Non Greaseable		UJ254
Brute Force Non Greaseable		UJ254	(For Aluminum Drive Shaft)		UJ354C
(For Aluminum Drive Shaft)		UJ354C	U-Joint (Rr. Shaft; Frt.)③		UJ316
U-Joint (Rr. Shaft; Frt.)③		UJ330	Brute Force Greaseable		UJ248
Brute Force Greaseable		UJ295	Clamp Kit (Rr. Shaft; Frt.)		UJ316-10
(For Aluminum Drive Shaft)		UJ330C	U-Joint (Rr. Shaft; Rr.)④		UJ316
U-Joint (Rr. Shaft; Ctr.)④		UJ330	Brute Force Greaseable		UJ248
Brute Force Greaseable		UJ295	Clamp Kit (Rr. Shaft; Rr.)		UJ316-10
(For Aluminum Drive Shaft)		UJ330C	U-Joint (Wheel Joint)⑤	[2]	UJ371
U-Joint (Rr. Shaft; Rr.)⑤		UJ330	Brute Force Greaseable		UJ377
Brute Force Greaseable		UJ295	Brute Force Non Greaseable		UJ371
(For Aluminum Drive Shaft)		UJ330C	Centering Ball Kit		UJ617
Clamp Kit (Rr. Shaft; Rr.)		UJ331-10	Flange Yoke		UJ628C
U-Joint (Wheel Joint)⑥	[2]	UJ374	H Yoke		UJ648
Brute Force Non Greaseable		UJ374BF	1996-1994 R2500 w/ 5.9L Diesel Eng., 2 Joint Rr. Shaft & 1.188" Dia. Whl. Joint Brg. Caps: [Type 26]		
Centering Ball Kit		UJ617	U-Joint (Frt. Shaft; Frt.)①		UJ316
Flange Yoke		UJ628C	Brute Force Greaseable		UJ248
H Yoke		UJ648	Clamp Kit (Frt. Shaft; Frt.)		UJ316-10
1999-1997 R2500 w/ Frt. Shaft Outer Lock Rings, 1.375" Dia. Whl. Joint Brg. Caps, 2 Joint Rr. Shaft & Inner Lock Rings: [Type 26]			U-Joint (Frt. Shaft; Rr.)②	[2]	UJ354
U-Joint (Frt. Shaft; Frt.)①		UJ458	Brute Force Greaseable		UJ270
(For Aluminum Drive Shaft)		UJ458C	Brute Force Non Greaseable		UJ254
Brute Force Non Greaseable		UJ458BF	(For Aluminum Drive Shaft)		UJ354C
U-Joint (Frt. Shaft; Rr.)②	[2]	UJ354	U-Joint (Rr. Shaft; Frt.)③		UJ330
Brute Force Greaseable		UJ270	Brute Force Greaseable		UJ295
Brute Force Non Greaseable		UJ254	(For Aluminum Drive Shaft)		UJ330C
(For Aluminum Drive Shaft)		UJ354C	U-Joint (Rr. Shaft; Rr.)④		UJ330
U-Joint (Rr. Shaft; Frt.)③		UJ316	Brute Force Greaseable		UJ295
Brute Force Greaseable		UJ248	(For Aluminum Drive Shaft)		UJ330C
Clamp Kit (Rr. Shaft; Frt.)		UJ316-10	Clamp Kit (Rr. Shaft; Rr.)		UJ331-10
U-Joint (Rr. Shaft; Rr.)④		UJ316	U-Joint (Wheel Joint)⑤	[2]	UJ371
Brute Force Greaseable		UJ248	Brute Force Greaseable		UJ377
Clamp Kit (Rr. Shaft; Rr.)		UJ316-10	Brute Force Non Greaseable		UJ371
U-Joint (Wheel Joint)⑤	[2]	UJ374	Centering Ball Kit		UJ617
Brute Force Non Greaseable		UJ374BF	Flange Yoke		UJ628C
Centering Ball Kit		UJ617	H Yoke		UJ648
Flange Yoke		UJ628C			(Continued)
H Yoke		UJ648			

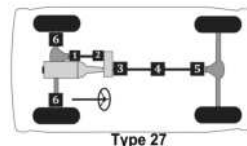
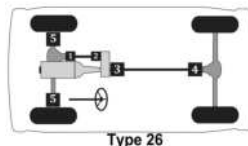

Passenger cars, light & medium trucks

Dodge Truck 3/4 ton -- (Cont.)

MFG./YEAR	MODEL & LOCATION	PART NO.	MFG./YEAR	MODEL & LOCATION	PART NO.
Drive Shaft (4 W/D) (Cont.)			Drive Shaft (4 W/D) (Cont.)		
U-Joint (Cont.)			U-Joint (Cont.)		
1996-1994 R2500 w/ 5.2L, 5.9L Gas Eng. & 1.375" Dia. Whl. Joint Brg. Caps:			1996-1994 R2500 w/ 5.9L Diesel Eng., 3 Joint Rr. Shaft & 1.188" Dia. Whl. Joint Brg. Caps: [Type 27]		
[Type 26]					
U-Joint (Fr. Shaft; Frt.) [⊙]		UJ316	U-Joint (Fr. Shaft; Frt.) [⊙]		UJ316
Brute Force Greaseable		UJ248	Brute Force Greaseable		UJ248
Clamp Kit (Fr. Shaft; Frt.)		UJ316-10	Clamp Kit (Fr. Shaft; Frt.)		UJ316-10
U-Joint (Fr. Shaft; Rr.) [⊙]	[2]	UJ354	U-Joint (Fr. Shaft; Rr.) [⊙]	[2]	UJ354
Brute Force Greaseable		UJ270	Brute Force Greaseable		UJ270
Brute Force Non Greaseable		UJ254	Brute Force Non Greaseable		UJ254
(For Aluminum Drive Shaft)		UJ354C	(For Aluminum Drive Shaft)		UJ354C
U-Joint (Rr. Shaft; Frt.) [⊙]		UJ316	U-Joint (Rr. Shaft; Frt.) [⊙]		UJ330
Brute Force Greaseable		UJ248	Brute Force Greaseable		UJ295
Clamp Kit (Rr. Shaft; Frt.)		UJ316-10	(For Aluminum Drive Shaft)		UJ330C
U-Joint (Rr. Shaft; Rr.) [⊙]		UJ316	U-Joint (Rr. Shaft; Ctr.) [⊙]		UJ330
Brute Force Greaseable		UJ248	Brute Force Greaseable		UJ295
Clamp Kit (Rr. Shaft; Rr.)		UJ316-10	(For Aluminum Drive Shaft)		UJ330C
U-Joint (Wheel Joint) [⊙]	[2]	UJ374	U-Joint (Rr. Shaft; Rr.) [⊙]		UJ330
Brute Force Non Greaseable		UJ374BF	Brute Force Greaseable		UJ295
Centering Ball Kit		UJ617	(For Aluminum Drive Shaft)		UJ330C
Flange Yoke		UJ628C	Clamp Kit (Rr. Shaft; Rr.)		UJ331-10
H Yoke		UJ648	U-Joint (Wheel Joint) [⊙]	[2]	UJ371
1996-1994 R2500 w/ 5.9L Diesel Eng., 2 Joint Rr. Shaft & 1.375" Dia. Whl. Joint Brg. Caps: [Type 26]			Brute Force Greaseable		UJ377
U-Joint (Fr. Shaft; Frt.) [⊙]		UJ316	Brute Force Non Greaseable		UJ371
Brute Force Greaseable		UJ248	Centering Ball Kit		UJ617
Clamp Kit (Fr. Shaft; Frt.)		UJ316-10	Flange Yoke		UJ628C
U-Joint (Fr. Shaft; Rr.) [⊙]	[2]	UJ354	H Yoke		UJ648
Brute Force Greaseable		UJ270			(Continued)
Brute Force Non Greaseable		UJ254			
(For Aluminum Drive Shaft)		UJ354C			
U-Joint (Rr. Shaft; Frt.) [⊙]		UJ330			
Brute Force Greaseable		UJ295			
(For Aluminum Drive Shaft)		UJ330C			
U-Joint (Rr. Shaft; Rr.) [⊙]		UJ330			
Brute Force Greaseable		UJ295			
(For Aluminum Drive Shaft)		UJ330C			
Clamp Kit (Rr. Shaft; Rr.)		UJ331-10			
U-Joint (Wheel Joint) [⊙]	[2]	UJ374			
Brute Force Non Greaseable		UJ374BF			
Centering Ball Kit		UJ617			
Flange Yoke		UJ628C			
H Yoke		UJ648			

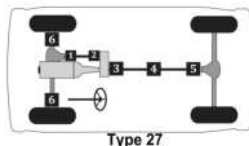
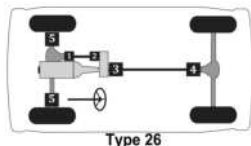

MFG./YEAR	MODEL & LOCATION	PART NO.	MFG./YEAR	MODEL & LOCATION	PART NO.
Drive Shaft (4 W/D) (Cont.)			Drive Shaft (4 W/D) (Cont.)		
U-Joint (Cont.)			U-Joint (Cont.)		
1996-1994 R2500 w/ 5.9L Diesel Eng., 3 Joint Rr. Shaft & 1.375" Dia. Whl. Joint Brg. Caps: [Type 27]			1996-1994 R2500 w/ 8.0L Eng., 2 Joint Rr. Shaft & 1.188" Dia. Whl. Joint Brg. Caps: [Type 26]		
U-Joint (Frnt. Shaft; Frnt.)		UJ316	U-Joint (Frnt. Shaft; Frnt.)		UJ316
Brute Force Greaseable		UJ248	Brute Force Greaseable		UJ248
Clamp Kit (Frnt. Shaft; Frnt.)		UJ316-10	Clamp Kit (Frnt. Shaft; Frnt.)		UJ316-10
U-Joint (Frnt. Shaft; Rr.)	[2]	UJ354	U-Joint (Frnt. Shaft; Rr.)	[2]	UJ354
Brute Force Greaseable		UJ270	Brute Force Greaseable		UJ270
Brute Force Non Greaseable		UJ254	Brute Force Non Greaseable		UJ254
(For Aluminum Drive Shaft)		UJ354C	(For Aluminum Drive Shaft)		UJ354C
U-Joint (Rr. Shaft; Frnt.)		UJ330	U-Joint (Rr. Shaft; Frnt.)		UJ330
Brute Force Greaseable		UJ295	Brute Force Greaseable		UJ295
(For Aluminum Drive Shaft)		UJ330C	(For Aluminum Drive Shaft)		UJ330C
U-Joint (Rr. Shaft; Ctr.)		UJ330	U-Joint (Rr. Shaft; Rr.)		UJ330
Brute Force Greaseable		UJ295	Brute Force Greaseable		UJ295
(For Aluminum Drive Shaft)		UJ330C	(For Aluminum Drive Shaft)		UJ330C
U-Joint (Rr. Shaft; Rr.)		UJ330	Clamp Kit (Rr. Shaft; Rr.)		UJ331-10
Brute Force Greaseable		UJ295	U-Joint (Wheel Joint)	[2]	UJ371
(For Aluminum Drive Shaft)		UJ330C	Brute Force Greaseable		UJ377
Clamp Kit (Rr. Shaft; Rr.)		UJ331-10	Brute Force Non Greaseable		UJ371
U-Joint (Wheel Joint)	[2]	UJ374	Centering Ball Kit		UJ617
Brute Force Non Greaseable		UJ374BF	Flange Yoke		UJ628C
Centering Ball Kit		UJ617	H Yoke		UJ648
Flange Yoke		UJ628C			
H Yoke		UJ648			
1996-1994 R2500 w/ 8.0L Eng., 3 Joint Rr. Shaft & 1.375" Dia. Whl. Joint Brg. Caps: [Type 27]			1996-1994 R2500 w/ 8.0L Eng., 2 Joint Rr. Shaft & 1.375" Dia. Whl. Joint Brg. Caps: [Type 26]		
U-Joint (Frnt. Shaft; Frnt.)		UJ316	U-Joint (Frnt. Shaft; Frnt.)		UJ316
Brute Force Greaseable		UJ248	Brute Force Greaseable		UJ248
Clamp Kit (Frnt. Shaft; Frnt.)		UJ316-10	Clamp Kit (Frnt. Shaft; Frnt.)		UJ316-10
U-Joint (Frnt. Shaft; Rr.)	[2]	UJ354	U-Joint (Frnt. Shaft; Rr.)	[2]	UJ354
Brute Force Greaseable		UJ270	Brute Force Greaseable		UJ270
Brute Force Non Greaseable		UJ254	Brute Force Non Greaseable		UJ254
(For Aluminum Drive Shaft)		UJ354C	(For Aluminum Drive Shaft)		UJ354C
U-Joint (Rr. Shaft; Frnt.)		UJ330	U-Joint (Rr. Shaft; Frnt.)		UJ330
Brute Force Greaseable		UJ295	Brute Force Greaseable		UJ295
(For Aluminum Drive Shaft)		UJ330C	(For Aluminum Drive Shaft)		UJ330C
U-Joint (Rr. Shaft; Ctr.)		UJ330	U-Joint (Rr. Shaft; Rr.)		UJ330
Brute Force Greaseable		UJ295	Brute Force Greaseable		UJ295
(For Aluminum Drive Shaft)		UJ330C	(For Aluminum Drive Shaft)		UJ330C
U-Joint (Rr. Shaft; Rr.)		UJ330	Clamp Kit (Rr. Shaft; Rr.)		UJ331-10
Brute Force Greaseable		UJ295	U-Joint (Wheel Joint)	[2]	UJ374
(For Aluminum Drive Shaft)		UJ330C	Brute Force Non Greaseable		UJ374BF
Clamp Kit (Rr. Shaft; Rr.)		UJ331-10	Centering Ball Kit		UJ617
U-Joint (Wheel Joint)	[2]	UJ374	Flange Yoke		UJ628C
Brute Force Non Greaseable		UJ374BF	H Yoke		UJ648
Centering Ball Kit		UJ617			
Flange Yoke		UJ628C			
H Yoke		UJ648			

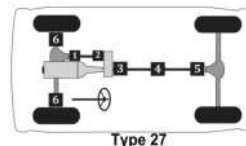
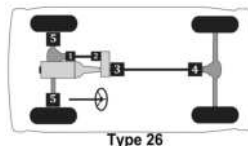

Passenger cars, light & medium trucks

Dodge Truck 3/4 ton -- (Cont.)

MFG./YEAR	MODEL & LOCATION	PART NO.	MFG./YEAR	MODEL & LOCATION	PART NO.
Drive Shaft (4 W/D) (Cont.)			Drive Shaft (4 W/D) (Cont.)		
U-Joint (Cont.)			U-Joint (Cont.)		
1996-1994 R2500 w/ 8.0L Eng., 3 Joint Rr. Shaft & 1.188" Dia. Whl. Joint Brg. Caps:			1993-1992 W250 w/ Diesel Eng., 2.125" Frt. Axle Yoke, 2 Joint Rr. Shaft & 1.188" Dia. Whl. Joint Brg. Caps: [Type 26]		
[Type 27]			[Type 26]		
U-Joint (Frt. Shaft; Frt.)Ⓚ		UJ316	U-Joint (Frt. Shaft; Frt.)Ⓚ		UJ317
Brute Force Greaseable		UJ248	Brute Force Greaseable		UJ246
Clamp Kit (Frt. Shaft; Frt.)		UJ316-10	Clamp Kit (Frt. Shaft; Frt.)		UJ318-10
U-Joint (Frt. Shaft; Rr.)Ⓚ	[2]	UJ354	U-Joint (Frt. Shaft; Rr.)Ⓚ	[2]	UJ534G
Brute Force Greaseable		UJ270	Brute Force Greaseable		UJ235
Brute Force Non Greaseable		UJ254	Brute Force Non Greaseable		UJ234
(For Aluminum Drive Shaft)		UJ354C	U-Joint (Rr. Shaft; Frt.)Ⓚ		UJ330
U-Joint (Rr. Shaft; Frt.)Ⓚ		UJ330	Brute Force Greaseable		UJ295
Brute Force Greaseable		UJ295	(For Aluminum Drive Shaft)		UJ330C
(For Aluminum Drive Shaft)		UJ330C	U-Joint (Rr. Shaft; Rr.)Ⓚ		UJ330
U-Joint (Rr. Shaft; Ctr.)Ⓚ		UJ330	Brute Force Greaseable		UJ295
Brute Force Greaseable		UJ295	(For Aluminum Drive Shaft)		UJ330C
(For Aluminum Drive Shaft)		UJ330C	U-Joint (Wheel Joint)Ⓚ	[2]	UJ371
U-Joint (Rr. Shaft; Rr.)Ⓚ		UJ330	Brute Force Greaseable		UJ377
Brute Force Greaseable		UJ295	Brute Force Non Greaseable		UJ371
(For Aluminum Drive Shaft)		UJ330C	Ball Seat Repair Kit		UJ606
Clamp Kit (Rr. Shaft; Rr.)		UJ331-10	Flange Yoke		UJ626
U-Joint (Wheel Joint)Ⓚ		UJ371	H Yoke		UJ646
Brute Force Greaseable		UJ377	1993-1992 W250 w/ Diesel Eng., 2.125" Frt. Axle Yoke, 2 Joint Rr. Shaft & 1.375" Dia. Whl. Joint Brg. Caps: [Type 26]		
Brute Force Non Greaseable		UJ371	U-Joint (Frt. Shaft; Frt.)Ⓚ		UJ317
Centering Ball Kit		UJ617	Brute Force Greaseable		UJ246
Flange Yoke		UJ628C	Clamp Kit (Frt. Shaft; Frt.)		UJ318-10
H Yoke		UJ648	U-Joint (Frt. Shaft; Rr.)Ⓚ	[2]	UJ534G
1993-1992 W250 w/ Diesel Eng., 2.625" Frt. Axle Yoke, 3 Joint Rr. Shaft & 1.375" Dia. Whl. Joint Brg. Caps: [Type 27]			Brute Force Greaseable		UJ235
U-Joint (Frt. Shaft; Frt.)Ⓚ		UJ316	Brute Force Non Greaseable		UJ234
Brute Force Greaseable		UJ248	U-Joint (Rr. Shaft; Frt.)Ⓚ		UJ330
Clamp Kit (Frt. Shaft; Frt.)		UJ316-10	Brute Force Greaseable		UJ295
U-Joint (Frt. Shaft; Rr.)Ⓚ	[2]	UJ534G	(For Aluminum Drive Shaft)		UJ330C
Brute Force Greaseable		UJ235	U-Joint (Rr. Shaft; Rr.)Ⓚ		UJ330
Brute Force Non Greaseable		UJ234	Brute Force Greaseable		UJ295
U-Joint (Rr. Shaft; Frt.)Ⓚ		UJ330	(For Aluminum Drive Shaft)		UJ330C
Brute Force Greaseable		UJ295	U-Joint (Wheel Joint)Ⓚ	[2]	UJ374
(For Aluminum Drive Shaft)		UJ330C	Brute Force Non Greaseable		UJ374BF
U-Joint (Rr. Shaft; Ctr.)Ⓚ		UJ330	Ball Seat Repair Kit		UJ606
Brute Force Greaseable		UJ295	Flange Yoke		UJ626
(For Aluminum Drive Shaft)		UJ330C	H Yoke		UJ646
U-Joint (Rr. Shaft; Rr.)Ⓚ		UJ330			(Continued)
Brute Force Greaseable		UJ295			
(For Aluminum Drive Shaft)		UJ330C			
U-Joint (Wheel Joint)Ⓚ	[2]	UJ374			
Brute Force Non Greaseable		UJ374BF			
Ball Seat Repair Kit		UJ606			
Flange Yoke		UJ626			
H Yoke		UJ646			

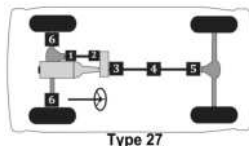
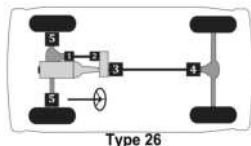

260 ▲ For Use w/ 1.063" Bearing Cap Application. Ⓚ For Use w/ 1.188" Bearing Cap Application. ◇ For Use w/ Inner Lock Ring Application on Half Shaft. □ For Use w/ Outer Lock Ring Application on Half Shaft.

MFG./YEAR	MODEL & LOCATION	PART NO.	MFG./YEAR	MODEL & LOCATION	PART NO.
Drive Shaft (4 W/D) (Cont.)			Drive Shaft (4 W/D) (Cont.)		
U-Joint (Cont.)			U-Joint (Cont.)		
1993-1992 W250 w/ Diesel Eng., 2.125" Frt. Axle			1993-1992 W250 w/ Diesel Eng., 2.625" Frt. Axle		
Yoke, 3 Joint Rr. Shaft & 1.375" Dia.			Yoke, 2 Joint Rr. Shaft & 1.188" Dia.		
Whl. Joint Brg. Caps: [Type 27]			Whl. Joint Brg. Caps: [Type 26]		
U-Joint (Frt. Shaft; Frt.)ⓐ		UJ317	U-Joint (Frt. Shaft; Frt.)ⓐ		UJ316
Brute Force Greaseable		UJ246	Brute Force Greaseable		UJ248
Clamp Kit (Frt. Shaft; Frt.)		UJ318-10	Clamp Kit (Frt. Shaft; Frt.)		UJ316-10
U-Joint (Frt. Shaft; Rr.)ⓑ	[2]	UJ534G	U-Joint (Frt. Shaft; Rr.)ⓑ	[2]	UJ534G
Brute Force Greaseable		UJ235	Brute Force Greaseable		UJ235
Brute Force Non Greaseable		UJ234	Brute Force Non Greaseable		UJ234
U-Joint (Rr. Shaft; Frt.)ⓐ		UJ330	U-Joint (Rr. Shaft; Frt.)ⓐ		UJ330
Brute Force Greaseable		UJ295	Brute Force Greaseable		UJ295
(For Aluminum Drive Shaft)		UJ330C	(For Aluminum Drive Shaft)		UJ330C
U-Joint (Rr. Shaft; Ctr.)ⓑ		UJ330	U-Joint (Rr. Shaft; Rr.)ⓑ		UJ330
Brute Force Greaseable		UJ295	Brute Force Greaseable		UJ295
(For Aluminum Drive Shaft)		UJ330C	(For Aluminum Drive Shaft)		UJ330C
U-Joint (Rr. Shaft; Rr.)ⓑ		UJ330	U-Joint (Wheel Joint)ⓐ	[2]	UJ371
Brute Force Greaseable		UJ295	Brute Force Greaseable		UJ377
(For Aluminum Drive Shaft)		UJ330C	Brute Force Non Greaseable		UJ371
U-Joint (Wheel Joint)ⓐ	[2]	UJ374	Ball Seat Repair Kit		UJ606
Brute Force Non Greaseable		UJ374BF	Flange Yoke		UJ626
Ball Seat Repair Kit		UJ606	H Yoke		UJ646
Flange Yoke		UJ626	1993-1992 W250 w/ Diesel Eng., 2.625" Frt. Axle		
H Yoke		UJ646	Yoke, 2 Joint Rr. Shaft & 1.375" Dia.		
1993-1992 W250 w/ Diesel Eng., 2.125" Frt. Axle			Whl. Joint Brg. Caps: [Type 26]		
Yoke, 3 Joint Rr. Shaft & 1.188" Dia.			U-Joint (Frt. Shaft; Frt.)ⓐ		
Whl. Joint Brg. Caps: [Type 27]			Brute Force Greaseable		
U-Joint (Frt. Shaft; Frt.)ⓐ		UJ317	Clamp Kit (Frt. Shaft; Frt.)		
Brute Force Greaseable		UJ246	U-Joint (Frt. Shaft; Rr.)ⓑ		
Clamp Kit (Frt. Shaft; Frt.)		UJ318-10	Brute Force Greaseable		
U-Joint (Frt. Shaft; Rr.)ⓑ	[2]	UJ534G	Brute Force Non Greaseable		
Brute Force Greaseable		UJ235	U-Joint (Rr. Shaft; Frt.)ⓐ		
Brute Force Non Greaseable		UJ234	Brute Force Greaseable		
U-Joint (Rr. Shaft; Frt.)ⓐ		UJ330	(For Aluminum Drive Shaft)		
Brute Force Greaseable		UJ295	U-Joint (Rr. Shaft; Rr.)ⓑ		
(For Aluminum Drive Shaft)		UJ330C	Brute Force Greaseable		
U-Joint (Rr. Shaft; Ctr.)ⓑ		UJ330	(For Aluminum Drive Shaft)		
Brute Force Greaseable		UJ295	U-Joint (Wheel Joint)ⓐ		
(For Aluminum Drive Shaft)		UJ330C	Brute Force Non Greaseable		
U-Joint (Rr. Shaft; Rr.)ⓑ		UJ330	Ball Seat Repair Kit		
Brute Force Greaseable		UJ295	Flange Yoke		
(For Aluminum Drive Shaft)		UJ330C	H Yoke		
U-Joint (Wheel Joint)ⓐ	[2]	UJ371			
Brute Force Greaseable		UJ377			
Brute Force Non Greaseable		UJ371			
Ball Seat Repair Kit		UJ606			
Flange Yoke		UJ626			
H Yoke		UJ646			

(Continued)

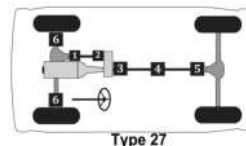
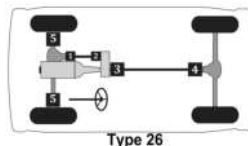

Passenger cars, light & medium trucks

Dodge Truck 3/4 ton -- (Cont.)

MFG./YEAR	MODEL & LOCATION	PART NO.	MFG./YEAR	MODEL & LOCATION	PART NO.
Drive Shaft (4 W/D) (Cont.)			Drive Shaft (4 W/D) (Cont.)		
U-Joint (Cont.)			U-Joint (Cont.)		
1993-1992 W250 w/ Diesel Eng., 2.625" Frt. Axle			1993-1992 W250 w/ Gas Eng., 2.125" Frt. Axle		
Yoke, 3 Joint Rr. Shaft & 1.188" Dia.			Yoke, 2 Joint Rr. Shaft & 1.375" Dia.		
Whl. Joint Brg. Caps: [Type 27]			Whl. Joint Brg. Caps: [Type 26]		
U-Joint (Frt. Shaft; Frt.)Ⓚ		UJ316	U-Joint (Frt. Shaft; Frt.)Ⓚ		UJ317
Brute Force Greaseable		UJ248	Brute Force Greaseable		UJ246
Clamp Kit (Frt. Shaft; Frt.)		UJ316-10	U-Joint (Frt. Shaft; Rr.)Ⓚ	[2]	UJ534G
U-Joint (Frt. Shaft; Rr.)Ⓚ	[2]	UJ534G	Brute Force Greaseable		UJ235
Brute Force Greaseable		UJ235	Brute Force Non Greaseable		UJ234
Brute Force Non Greaseable		UJ234	U-Joint (Rr. Shaft; Frt.)Ⓚ		UJ316
U-Joint (Rr. Shaft; Frt.)Ⓚ		UJ330	Brute Force Greaseable		UJ248
Brute Force Greaseable		UJ295	U-Joint (Rr. Shaft; Rr.)Ⓚ		UJ316
(For Aluminum Drive Shaft)		UJ330C	Brute Force Greaseable		UJ248
U-Joint (Rr. Shaft; Ctr.)Ⓚ		UJ330	U-Joint (Wheel Joint)Ⓚ	[2]	UJ374
Brute Force Greaseable		UJ295	Brute Force Non Greaseable		UJ374BF
(For Aluminum Drive Shaft)		UJ330C	Ball Seat Repair Kit		UJ606
U-Joint (Rr. Shaft; Rr.)Ⓚ		UJ330	Flange Yoke		UJ626
Brute Force Greaseable		UJ295	H Yoke		UJ646
(For Aluminum Drive Shaft)		UJ330C	1993-1992 W250 w/ Gas Eng., 2.125" Frt. Axle		
U-Joint (Wheel Joint)Ⓚ	[2]	UJ371	Yoke, 3 Joint Rr. Shaft & 1.188" Dia.		
Brute Force Greaseable		UJ377	Whl. Joint Brg. Caps: [Type 27]		
Brute Force Non Greaseable		UJ371	U-Joint (Frt. Shaft; Frt.)Ⓚ		UJ317
Ball Seat Repair Kit		UJ606	Brute Force Greaseable		UJ246
Flange Yoke		UJ626	U-Joint (Frt. Shaft; Rr.)Ⓚ	[2]	UJ534G
H Yoke		UJ646	Brute Force Greaseable		UJ235
1993-1992 W250 w/ Gas Eng., 2.125" Frt. Axle			Brute Force Non Greaseable		UJ234
Yoke, 2 Joint Rr. Shaft & 1.188" Dia.			U-Joint (Rr. Shaft; Frt.)Ⓚ		UJ316
Whl. Joint Brg. Caps: [Type 26]			Brute Force Greaseable		UJ248
U-Joint (Frt. Shaft; Frt.)Ⓚ		UJ317	U-Joint (Rr. Shaft; Ctr.)Ⓚ		UJ316
Brute Force Greaseable		UJ246	Brute Force Greaseable		UJ248
Clamp Kit (Frt. Shaft; Frt.)		UJ318-10	U-Joint (Rr. Shaft; Rr.)Ⓚ		UJ316
U-Joint (Frt. Shaft; Rr.)Ⓚ	[2]	UJ534G	Brute Force Greaseable		UJ248
Brute Force Greaseable		UJ235	U-Joint (Wheel Joint)Ⓚ	[2]	UJ371
Brute Force Non Greaseable		UJ234	Brute Force Greaseable		UJ377
U-Joint (Rr. Shaft; Frt.)Ⓚ		UJ316	Brute Force Non Greaseable		UJ371
Brute Force Greaseable		UJ248	Ball Seat Repair Kit		UJ606
U-Joint (Rr. Shaft; Rr.)Ⓚ		UJ316	Flange Yoke		UJ626
Brute Force Greaseable		UJ248	H Yoke		UJ646
U-Joint (Wheel Joint)Ⓚ	[2]	UJ371			(Continued)
Brute Force Greaseable		UJ377			
Brute Force Non Greaseable		UJ371			
Ball Seat Repair Kit		UJ606			
Flange Yoke		UJ626			
H Yoke		UJ646			

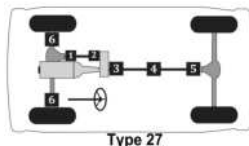
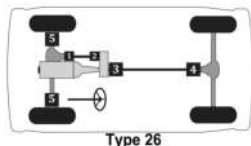

MFG./YEAR	MODEL & LOCATION	PART NO.	MFG./YEAR	MODEL & LOCATION	PART NO.
Drive Shaft (4 W/D) (Cont.)			Drive Shaft (4 W/D) (Cont.)		
U-Joint (Cont.)			U-Joint (Cont.)		
1993-1992 W250 w/ Gas Eng., 2.125" Frt. Axle			1993-1992 W250 w/ Gas Eng., 2.625" Frt. Axle		
Yoke, 3 Joint Rr. Shaft & 1.375" Dia.			Yoke, 2 Joint Rr. Shaft & 1.188" Dia.		
Whl. Joint Brg. Caps: [Type 27]			Whl. Joint Brg. Caps: [Type 26]		
U-Joint (Frt. Shaft; Frt.)①		UJ317	U-Joint (Frt. Shaft; Frt.)①		UJ316
Brute Force Greaseable		UJ246	Brute Force Greaseable		UJ248
U-Joint (Frt. Shaft; Rr.)②	[2]	UJ534G	Clamp Kit (Frt. Shaft; Frt.)		UJ316-10
Brute Force Greaseable		UJ235	U-Joint (Frt. Shaft; Rr.)②	[2]	UJ534G
Brute Force Non Greaseable		UJ234	Brute Force Greaseable		UJ235
U-Joint (Rr. Shaft; Frt.)③		UJ316	Brute Force Non Greaseable		UJ234
Brute Force Greaseable		UJ248	U-Joint (Rr. Shaft; Frt.)③		UJ316
U-Joint (Rr. Shaft; Ctr.)④		UJ316	Brute Force Greaseable		UJ248
Brute Force Greaseable		UJ248	U-Joint (Rr. Shaft; Rr.)⑤		UJ316
U-Joint (Rr. Shaft; Rr.)⑤		UJ316	Brute Force Greaseable		UJ248
Brute Force Greaseable		UJ248	U-Joint (Wheel Joint)⑥	[2]	UJ371
U-Joint (Wheel Joint)⑥	[2]	UJ374	Brute Force Greaseable		UJ377
Brute Force Non Greaseable		UJ374BF	Brute Force Non Greaseable		UJ377
Ball Seat Repair Kit		UJ606	Ball Seat Repair Kit		UJ606
Flange Yoke		UJ626	Flange Yoke		UJ626
H Yoke		UJ646	H Yoke		UJ646
1993-1992 W250 w/ Gas Eng., 2.625" Frt. Axle			1993-1992 W250 w/ Gas Eng., 2.625" Frt. Axle		
Yoke, 3 Joint Rr. Shaft & 1.375" Dia.			Yoke, 3 Joint Rr. Shaft & 1.188" Dia.		
Whl. Joint Brg. Caps: [Type 27]			Whl. Joint Brg. Caps: [Type 27]		
U-Joint (Frt. Shaft; Frt.)①		UJ316	U-Joint (Frt. Shaft; Frt.)①		UJ316
Brute Force Greaseable		UJ248	Brute Force Greaseable		UJ248
Clamp Kit (Frt. Shaft; Frt.)		UJ316-10	Clamp Kit (Frt. Shaft; Frt.)		UJ316-10
U-Joint (Frt. Shaft; Rr.)②	[2]	UJ534G	U-Joint (Frt. Shaft; Rr.)②	[2]	UJ534G
Brute Force Greaseable		UJ235	Brute Force Greaseable		UJ235
Brute Force Non Greaseable		UJ234	Brute Force Non Greaseable		UJ234
U-Joint (Rr. Shaft; Frt.)③		UJ316	U-Joint (Rr. Shaft; Frt.)③		UJ316
Brute Force Greaseable		UJ248	Brute Force Greaseable		UJ248
U-Joint (Rr. Shaft; Ctr.)④		UJ316	U-Joint (Rr. Shaft; Ctr.)④		UJ316
Brute Force Greaseable		UJ248	Brute Force Greaseable		UJ248
U-Joint (Rr. Shaft; Rr.)⑤		UJ316	U-Joint (Rr. Shaft; Rr.)⑤		UJ316
Brute Force Greaseable		UJ248	Brute Force Greaseable		UJ248
U-Joint (Wheel Joint)⑥	[2]	UJ374	U-Joint (Wheel Joint)⑥	[2]	UJ371
Brute Force Non Greaseable		UJ374BF	Brute Force Greaseable		UJ377
Ball Seat Repair Kit		UJ606	Brute Force Non Greaseable		UJ377
Flange Yoke		UJ626	Ball Seat Repair Kit		UJ606
H Yoke		UJ646	Flange Yoke		UJ626
			H Yoke		UJ646

(Continued)

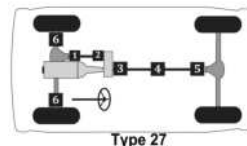
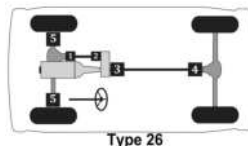

Passenger cars, light & medium trucks

Dodge Truck 3/4 ton -- (Cont.)

MFG./YEAR	MODEL & LOCATION	PART NO.	MFG./YEAR	MODEL & LOCATION	PART NO.
-----------	------------------	----------	-----------	------------------	----------

Drive Shaft (4 W/D) (Cont.)

U-Joint (Cont.)

1993-1992 W250 w/ Gas Eng., 2.625" Frt. Axle
Yoke, 2 Joint Rr. Shaft & 1.375" Dia.
Whl. Joint Brg. Caps: [Type 26]

U-Joint (Frt. Shaft; Frt.) [Ⓚ]	UJ316
Brute Force Greaseable	UJ248
Clamp Kit (Frt. Shaft; Frt.)	UJ316-10
U-Joint (Frt. Shaft; Rr.) [Ⓚ]	[2] UJ534G
Brute Force Greaseable	UJ235
Brute Force Non Greaseable	UJ234
U-Joint (Rr. Shaft; Frt.) [Ⓚ]	UJ316
Brute Force Greaseable	UJ248
U-Joint (Rr. Shaft; Rr.) [Ⓚ]	UJ316
Brute Force Greaseable	UJ248
U-Joint (Wheel Joint) [Ⓚ]	[2] UJ374
Brute Force Non Greaseable	UJ374BF
Ball Seat Repair Kit	UJ606
Flange Yoke	UJ626
H Yoke	UJ646

1991-1989 W250 w/ Gas Eng., 2.625" Frt. Axle
Yoke, 3 Joint Rr. Shaft & 1.375" Dia.
Whl. Joint Brg. Caps: [Type 27]

U-Joint (Frt. Shaft; Frt.) [Ⓚ]	UJ316
Brute Force Greaseable	UJ248
Clamp Kit (Frt. Shaft; Frt.)	UJ316-10
U-Joint (Frt. Shaft; Rr.) [Ⓚ]	[2] UJ534G
Brute Force Greaseable	UJ235
Brute Force Non Greaseable	UJ234
U-Joint (Rr. Shaft; Frt.) [Ⓚ]	UJ317
Brute Force Greaseable	UJ246
U-Joint (Rr. Shaft; Ctr.) [Ⓚ]	UJ317
Brute Force Greaseable	UJ246
U-Joint (Rr. Shaft; Rr.) [Ⓚ]	UJ317
Brute Force Greaseable	UJ246
U-Joint (Wheel Joint) [Ⓚ]	[2] UJ374
Brute Force Non Greaseable	UJ374BF
Ball Seat Repair Kit	UJ606
Flange Yoke	UJ626
H Yoke	UJ646

Drive Shaft (4 W/D) (Cont.)

U-Joint (Cont.)

1991-1989 W250 w/ Diesel Eng., 2.125" Frt. Axle
Yoke, 2 Joint Rr. Shaft & 1.188" Dia.
Whl. Joint Brg. Caps: [Type 26]

U-Joint (Frt. Shaft; Frt.) [Ⓚ]	UJ317
Brute Force Greaseable	UJ246
U-Joint (Frt. Shaft; Rr.) [Ⓚ]	[2] UJ534G
Brute Force Greaseable	UJ235
Brute Force Non Greaseable	UJ234
U-Joint (Rr. Shaft; Frt.) [Ⓚ]	UJ330
Brute Force Greaseable	UJ295
(For Aluminum Drive Shaft)	UJ330C
U-Joint (Rr. Shaft; Rr.) [Ⓚ]	UJ330
Brute Force Greaseable	UJ295
(For Aluminum Drive Shaft)	UJ330C
U-Joint (Wheel Joint) [Ⓚ]	[2] UJ371
Brute Force Greaseable	UJ377
Brute Force Non Greaseable	UJ371
Ball Seat Repair Kit	UJ606
Flange Yoke	UJ626
H Yoke	UJ646

1991-1989 W250 w/ Diesel Eng., 2.125" Frt. Axle
Yoke, 2 Joint Rr. Shaft & 1.375" Dia.
Whl. Joint Brg. Caps: [Type 26]

U-Joint (Frt. Shaft; Frt.) [Ⓚ]	UJ317
Brute Force Greaseable	UJ246
U-Joint (Frt. Shaft; Rr.) [Ⓚ]	[2] UJ534G
Brute Force Greaseable	UJ235
Brute Force Non Greaseable	UJ234
U-Joint (Rr. Shaft; Frt.) [Ⓚ]	UJ330
Brute Force Greaseable	UJ295
(For Aluminum Drive Shaft)	UJ330C
U-Joint (Rr. Shaft; Rr.) [Ⓚ]	UJ330
Brute Force Greaseable	UJ295
(For Aluminum Drive Shaft)	UJ330C
U-Joint (Wheel Joint) [Ⓚ]	[2] UJ374
Brute Force Non Greaseable	UJ374BF
Ball Seat Repair Kit	UJ606
Flange Yoke	UJ626
H Yoke	UJ646

(Continued)

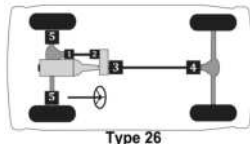

Type 26

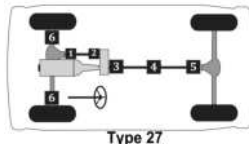

Type 27

MFG./YEAR	MODEL & LOCATION	PART NO.	MFG./YEAR	MODEL & LOCATION	PART NO.
Drive Shaft (4 W/D) (Cont.)			Drive Shaft (4 W/D) (Cont.)		
U-Joint (Cont.)			U-Joint (Cont.)		
1991-1989 W250 w/ Diesel Eng., 2.125" Frt. Axle			1991-1989 W250 w/ Gas Eng., 2.625" Frt. Axle		
Yoke, 3 Joint Rr. Shaft & 1.188" Dia.			Yoke, 3 Joint Rr. Shaft & 1.188" Dia.		
Whl. Joint Brg. Caps: [Type 27]			Whl. Joint Brg. Caps: [Type 27]		
U-Joint (Frt. Shaft; Frt.)①		UJ317	U-Joint (Frt. Shaft; Frt.)①		UJ316
Brute Force Greaseable		UJ246	Brute Force Greaseable		UJ248
U-Joint (Frt. Shaft; Rr.)②	[2]	UJ534G	Clamp Kit (Frt. Shaft; Frt.)		UJ316-10
Brute Force Greaseable		UJ235	U-Joint (Frt. Shaft; Rr.)②	[2]	UJ534G
Brute Force Non Greaseable		UJ234	Brute Force Greaseable		UJ235
U-Joint (Rr. Shaft; Frt.)③		UJ330	Brute Force Non Greaseable		UJ234
Brute Force Greaseable		UJ295	U-Joint (Rr. Shaft; Frt.)③		UJ317
(For Aluminum Drive Shaft)		UJ330C	Brute Force Greaseable		UJ246
U-Joint (Rr. Shaft; Ctr.)④		UJ330	U-Joint (Rr. Shaft; Ctr.)④		UJ317
Brute Force Greaseable		UJ295	Brute Force Greaseable		UJ246
(For Aluminum Drive Shaft)		UJ330C	U-Joint (Rr. Shaft; Rr.)⑤		UJ317
U-Joint (Rr. Shaft; Rr.)⑤		UJ330	Brute Force Greaseable		UJ246
Brute Force Greaseable		UJ295	U-Joint (Wheel Joint)⑥		UJ371
(For Aluminum Drive Shaft)		UJ330C	Brute Force Greaseable		UJ377
U-Joint (Wheel Joint)⑥	[2]	UJ371	Brute Force Non Greaseable		UJ371
Brute Force Greaseable		UJ377	Ball Seat Repair Kit		UJ606
Brute Force Non Greaseable		UJ371	Flange Yoke		UJ626
Ball Seat Repair Kit		UJ606	H Yoke		UJ646
Flange Yoke		UJ626			
H Yoke		UJ646			
1991-1989 W250 w/ Diesel Eng., 2.125" Frt. Axle			1991-1989 W250 w/ Diesel Eng., 2.625" Frt. Axle		
Yoke, 3 Joint Rr. Shaft & 1.375" Dia.			Yoke, 2 Joint Rr. Shaft & 1.188" Dia.		
Whl. Joint Brg. Caps: [Type 27]			Whl. Joint Brg. Caps: [Type 26]		
U-Joint (Frt. Shaft; Frt.)①		UJ317	U-Joint (Frt. Shaft; Frt.)①		UJ316
Brute Force Greaseable		UJ246	Brute Force Greaseable		UJ248
U-Joint (Frt. Shaft; Rr.)②	[2]	UJ534G	Clamp Kit (Frt. Shaft; Frt.)		UJ316-10
Brute Force Greaseable		UJ235	U-Joint (Frt. Shaft; Rr.)②	[2]	UJ534G
Brute Force Non Greaseable		UJ234	Brute Force Greaseable		UJ235
U-Joint (Rr. Shaft; Frt.)③		UJ330	Brute Force Non Greaseable		UJ234
Brute Force Greaseable		UJ295	U-Joint (Rr. Shaft; Frt.)③		UJ330
(For Aluminum Drive Shaft)		UJ330C	Brute Force Greaseable		UJ295
U-Joint (Rr. Shaft; Ctr.)④		UJ330	(For Aluminum Drive Shaft)		UJ330C
Brute Force Greaseable		UJ295	U-Joint (Rr. Shaft; Rr.)⑤		UJ330
(For Aluminum Drive Shaft)		UJ330C	Brute Force Greaseable		UJ295
U-Joint (Rr. Shaft; Rr.)⑤		UJ330	(For Aluminum Drive Shaft)		UJ330C
Brute Force Greaseable		UJ295	U-Joint (Wheel Joint)⑥	[2]	UJ371
(For Aluminum Drive Shaft)		UJ330C	Brute Force Greaseable		UJ377
U-Joint (Wheel Joint)⑥	[2]	UJ371	Brute Force Non Greaseable		UJ371
Brute Force Non Greaseable		UJ374BF	Ball Seat Repair Kit		UJ606
Ball Seat Repair Kit		UJ606	Flange Yoke		UJ626
Flange Yoke		UJ626	H Yoke		UJ646
H Yoke		UJ646			

(Continued)

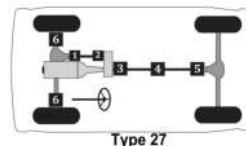
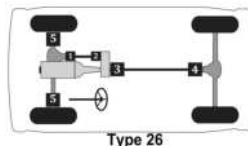

Passenger cars, light & medium trucks

Dodge Truck 3/4 ton -- (Cont.)

MFG./YEAR	MODEL & LOCATION	PART NO.	MFG./YEAR	MODEL & LOCATION	PART NO.
-----------	------------------	----------	-----------	------------------	----------

Drive Shaft (4 W/D) (Cont.)

U-Joint (Cont.)

1991-1989 W250 w/ Gas Eng., 2.625" Frt. Axle
Yoke, 2 Joint Rr. Shaft & 1.375" Dia.
Whl. Joint Brg. Caps: [Type 26]

U-Joint (Frt. Shaft; Frt.)Ⓚ	UJ316
Brute Force Greaseable	UJ248
Clamp Kit (Frt. Shaft; Frt.)	UJ316-10
U-Joint (Frt. Shaft; Rr.)Ⓚ [2]	UJ534G
Brute Force Greaseable	UJ235
Brute Force Non Greaseable	UJ234
U-Joint (Rr. Shaft; Frt.)Ⓚ	UJ317
Brute Force Greaseable	UJ246
U-Joint (Rr. Shaft; Rr.)Ⓚ	UJ317
Brute Force Greaseable	UJ246
U-Joint (Wheel Joint)Ⓚ [2]	UJ374
Brute Force Non Greaseable	UJ374BF
Ball Seat Repair Kit	UJ606
Flange Yoke	UJ626
H Yoke	UJ646

1991-1989 W250 w/ Diesel Eng., 2.625" Frt. Axle
Yoke, 2 Joint Rr. Shaft & 1.375" Dia.
Whl. Joint Brg. Caps: [Type 26]

U-Joint (Frt. Shaft; Frt.)Ⓚ	UJ316
Brute Force Greaseable	UJ248
Clamp Kit (Frt. Shaft; Frt.)	UJ316-10
U-Joint (Frt. Shaft; Rr.)Ⓚ [2]	UJ534G
Brute Force Greaseable	UJ235
Brute Force Non Greaseable	UJ234
U-Joint (Rr. Shaft; Frt.)Ⓚ	UJ330
Brute Force Greaseable	UJ295
(For Aluminum Drive Shaft)	UJ330C
U-Joint (Rr. Shaft; Rr.)Ⓚ	UJ330
Brute Force Greaseable	UJ295
(For Aluminum Drive Shaft)	UJ330C
U-Joint (Wheel Joint)Ⓚ [2]	UJ374
Brute Force Non Greaseable	UJ374BF
Ball Seat Repair Kit	UJ606
Flange Yoke	UJ626
H Yoke	UJ646

Drive Shaft (4 W/D) (Cont.)

U-Joint (Cont.)

1991-1989 W250 w/ Diesel Eng., 2.625" Frt. Axle
Yoke, 3 Joint Rr. Shaft & 1.188" Dia.
Whl. Joint Brg. Caps: [Type 27]

U-Joint (Frt. Shaft; Frt.)Ⓚ	UJ316
Brute Force Greaseable	UJ248
Clamp Kit (Frt. Shaft; Frt.)	UJ316-10
U-Joint (Frt. Shaft; Rr.)Ⓚ [2]	UJ534G
Brute Force Greaseable	UJ235
Brute Force Non Greaseable	UJ234
U-Joint (Rr. Shaft; Frt.)Ⓚ	UJ330
Brute Force Greaseable	UJ295
(For Aluminum Drive Shaft)	UJ330C
U-Joint (Rr. Shaft; Ctr.)Ⓚ	UJ330
Brute Force Greaseable	UJ295
(For Aluminum Drive Shaft)	UJ330C
U-Joint (Rr. Shaft; Rr.)Ⓚ	UJ330
Brute Force Greaseable	UJ295
(For Aluminum Drive Shaft)	UJ330C
U-Joint (Wheel Joint)Ⓚ [2]	UJ371
Brute Force Greaseable	UJ377
Brute Force Non Greaseable	UJ371
Ball Seat Repair Kit	UJ606
Flange Yoke	UJ626
H Yoke	UJ646

1991-1989 W250 w/ Gas Eng., 2.125" Frt. Axle
Yoke, 3 Joint Rr. Shaft & 1.375" Dia.
Whl. Joint Brg. Caps: [Type 27]

U-Joint (Frt. Shaft; Frt.)Ⓚ	UJ317
Brute Force Greaseable	UJ246
U-Joint (Frt. Shaft; Rr.)Ⓚ [2]	UJ534G
Brute Force Greaseable	UJ235
Brute Force Non Greaseable	UJ234
U-Joint (Rr. Shaft; Frt.)Ⓚ	UJ317
Brute Force Greaseable	UJ246
U-Joint (Rr. Shaft; Ctr.)Ⓚ	UJ317
Brute Force Greaseable	UJ246
U-Joint (Rr. Shaft; Rr.)Ⓚ	UJ317
Brute Force Greaseable	UJ246
U-Joint (Wheel Joint)Ⓚ [2]	UJ374
Brute Force Non Greaseable	UJ374BF
Ball Seat Repair Kit	UJ606
Flange Yoke	UJ626
H Yoke	UJ646

(Continued)

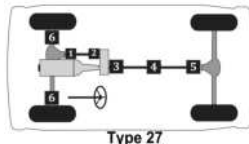
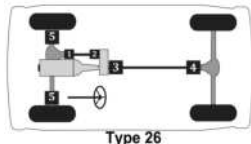

MFG./YEAR	MODEL & LOCATION	PART NO.	MFG./YEAR	MODEL & LOCATION	PART NO.
Drive Shaft (4 W/D) (Cont.)			Drive Shaft (4 W/D) (Cont.)		
U-Joint (Cont.)			U-Joint (Cont.)		
1991-1989 W250 w/ Diesel Eng., 2.625" Frt. Axle			1991-1989 W250 w/ Gas Eng., 2.125" Frt. Axle		
Yoke, 3 Joint Rr. Shaft & 1.375" Dia.			Yoke, 2 Joint Rr. Shaft & 1.375" Dia.		
Whl. Joint Brg. Caps: [Type 27]			Whl. Joint Brg. Caps: [Type 26]		
U-Joint (Frt. Shaft; Frt.)①		UJ316	U-Joint (Frt. Shaft; Frt.)①		UJ317
Brute Force Greaseable		UJ248	Brute Force Greaseable		UJ246
Clamp Kit (Frt. Shaft; Frt.)		UJ316-10	U-Joint (Frt. Shaft; Rr.)②	[2]	UJ534G
U-Joint (Frt. Shaft; Rr.)②	[2]	UJ534G	Brute Force Greaseable		UJ235
Brute Force Greaseable		UJ235	Brute Force Non Greaseable		UJ234
Brute Force Non Greaseable		UJ234	U-Joint (Rr. Shaft; Frt.)③		UJ317
U-Joint (Rr. Shaft; Frt.)③		UJ330	Brute Force Greaseable		UJ246
Brute Force Greaseable		UJ295	U-Joint (Rr. Shaft; Rr.)④		UJ317
(For Aluminum Drive Shaft)		UJ330C	Brute Force Greaseable		UJ246
U-Joint (Rr. Shaft; Ctr.)④		UJ330	U-Joint (Wheel Joint)⑤	[2]	UJ374
Brute Force Greaseable		UJ295	Brute Force Non Greaseable		UJ374BF
(For Aluminum Drive Shaft)		UJ330C	Ball Seat Repair Kit		UJ606
U-Joint (Rr. Shaft; Rr.)⑤		UJ330	Flange Yoke		UJ626
Brute Force Greaseable		UJ295	H Yoke		UJ646
(For Aluminum Drive Shaft)		UJ330C			
U-Joint (Wheel Joint)⑥	[2]	UJ374	1991-1989 W250 w/ Gas Eng., 2.125" Frt. Axle		
Brute Force Non Greaseable		UJ374BF	Yoke, 3 Joint Rr. Shaft & 1.188" Dia.		
Ball Seat Repair Kit		UJ606	Whl. Joint Brg. Caps: [Type 27]		
Flange Yoke		UJ626	U-Joint (Frt. Shaft; Frt.)①		UJ317
H Yoke		UJ646	Brute Force Greaseable		UJ246
			U-Joint (Frt. Shaft; Rr.)②	[2]	UJ534G
1991-1989 W250 w/ Gas Eng., 2.125" Frt. Axle			Brute Force Greaseable		UJ235
Yoke, 2 Joint Rr. Shaft & 1.188" Dia.			Brute Force Non Greaseable		UJ234
Whl. Joint Brg. Caps: [Type 26]			U-Joint (Rr. Shaft; Frt.)③		UJ317
U-Joint (Frt. Shaft; Frt.)①		UJ317	Brute Force Greaseable		UJ246
Brute Force Greaseable		UJ246	U-Joint (Rr. Shaft; Ctr.)④		UJ317
U-Joint (Frt. Shaft; Rr.)②	[2]	UJ534G	Brute Force Greaseable		UJ246
Brute Force Greaseable		UJ235	U-Joint (Rr. Shaft; Rr.)⑤		UJ317
Brute Force Non Greaseable		UJ234	Brute Force Greaseable		UJ246
U-Joint (Rr. Shaft; Frt.)③		UJ317	U-Joint (Wheel Joint)⑥		UJ371
Brute Force Greaseable		UJ246	Brute Force Greaseable		UJ377
U-Joint (Rr. Shaft; Rr.)④		UJ317	Brute Force Non Greaseable		UJ371
Brute Force Greaseable		UJ246	Ball Seat Repair Kit		UJ606
U-Joint (Wheel Joint)⑥	[2]	UJ371	Flange Yoke		UJ626
Brute Force Greaseable		UJ377	H Yoke		UJ646
Brute Force Non Greaseable		UJ371			
Ball Seat Repair Kit		UJ606			
Flange Yoke		UJ626			
H Yoke		UJ646			

(Continued)

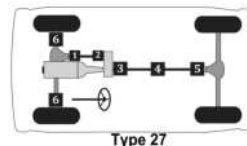
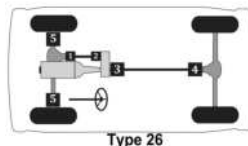

Passenger cars, light & medium trucks

Dodge Truck 3/4 ton -- (Cont.)

MFG./YEAR	MODEL & LOCATION	PART NO.	MFG./YEAR	MODEL & LOCATION	PART NO.
Drive Shaft (4 W/D) (Cont.)			Drive Shaft (4 W/D) (Cont.)		
U-Joint (Cont.)			U-Joint (Cont.)		
1991-1989 W250 w/ Gas Eng., 2.625" Frt. Axle Yoke, 2 Joint Rr. Shaft & 1.188" Dia. Whl. Joint Brg. Caps: [Type 26]			1988-1977 W200 & W250 w/ 2 Joint Rr Shaft, 2.125" Rr. Yoke & 1.188" Dia. Whl. Joint Brg. Caps: [Type 26]		
U-Joint (Frt. Shaft; Frt.)Ⓚ		UJ316	U-Joint (Frt. Shaft; Frt.)Ⓚ		UJ315G
Brute Force Greaseable		UJ248	Brute Force Greaseable		UJ246
Clamp Kit (Frt. Shaft; Frt.)		UJ316-10	Clamp Kit (Frt. Shaft; Frt.)		UJ318-10
U-Joint (Frt. Shaft; Rr.)Ⓛ	[2]	UJ534G	U-Joint (Frt. Shaft; Rr.)Ⓛ	[2]	UJ534G
Brute Force Greaseable		UJ235	Brute Force Greaseable		UJ235
Brute Force Non Greaseable		UJ234	Brute Force Non Greaseable		UJ234
U-Joint (Rr. Shaft; Frt.)Ⓛ		UJ317	U-Joint (Rr. Shaft; Frt.)Ⓛ		UJ315G
Brute Force Greaseable		UJ246	Brute Force Greaseable		UJ246
U-Joint (Rr. Shaft; Rr.)Ⓛ		UJ317	Clamp Kit (Rr. Shaft; Frt.)		UJ318-10
Brute Force Greaseable		UJ246	U-Joint (Rr. Shaft; Rr.)Ⓛ		UJ315G
U-Joint (Wheel Joint)Ⓛ	[2]	UJ371	Brute Force Greaseable		UJ246
Brute Force Greaseable		UJ377	Clamp Kit (Rr. Shaft; Rr.)		UJ318-10
Brute Force Non Greaseable		UJ371	U-Joint (Wheel Joint)Ⓛ	[2]	UJ371
Ball Seat Repair Kit		UJ606	Brute Force Greaseable		UJ377
Flange Yoke		UJ626	Brute Force Non Greaseable		UJ371
H Yoke		UJ646	Ball Seat Repair Kit		UJ606
1988-1977 W200 & W250 w/ 3 Joint Rr Shaft, 2.625" Rr. Yoke & 1.188" Dia. Whl. Joint Brg. Caps: [Type 27]			1988-1977 W200 & W250 w/ 2 Joint Rr Shaft, 2.125" Rr. Yoke & 1.375" Dia. Whl. Joint Brg. Caps: [Type 26]		
U-Joint (Frt. Shaft; Frt.)Ⓚ		UJ315G	U-Joint (Frt. Shaft; Frt.)Ⓚ		UJ315G
Brute Force Greaseable		UJ246	Brute Force Greaseable		UJ246
Clamp Kit (Frt. Shaft; Frt.)		UJ318-10	Clamp Kit (Frt. Shaft; Frt.)		UJ318-10
U-Joint (Frt. Shaft; Rr.)Ⓛ	[2]	UJ534G	U-Joint (Frt. Shaft; Rr.)Ⓛ	[2]	UJ534G
Brute Force Greaseable		UJ235	Brute Force Greaseable		UJ235
Brute Force Non Greaseable		UJ234	Brute Force Non Greaseable		UJ234
U-Joint (Rr. Shaft; Frt.)Ⓛ		UJ315G	U-Joint (Rr. Shaft; Frt.)Ⓛ		UJ315G
Brute Force Greaseable		UJ246	Brute Force Greaseable		UJ246
Clamp Kit (Rr. Shaft; Frt.)		UJ318-10	Clamp Kit (Rr. Shaft; Frt.)		UJ318-10
U-Joint (Rr. Shaft; Ctr.)Ⓛ		UJ315G	Brute Force Greaseable		UJ246
Brute Force Greaseable		UJ246	Clamp Kit (Rr. Shaft; Rr.)		UJ318-10
Clamp Kit (Rr. Shaft; Ctr.)		UJ318-10	U-Joint (Rr. Shaft; Rr.)Ⓛ		UJ315G
U-Joint (Rr. Shaft; Rr.)Ⓛ		UJ316	Brute Force Greaseable		UJ246
Brute Force Greaseable		UJ248	Clamp Kit (Rr. Shaft; Rr.)		UJ318-10
Clamp Kit (Rr. Shaft; Rr.)		UJ316-10	U-Joint (Wheel Joint)Ⓛ	[2]	UJ374
U-Joint (Wheel Joint)Ⓛ	[2]	UJ371	Brute Force Non Greaseable		UJ374BF
Brute Force Greaseable		UJ377	Ball Seat Repair Kit		UJ606
Brute Force Non Greaseable		UJ371	Flange Yoke		UJ626
Ball Seat Repair Kit		UJ606	H Yoke		UJ646
Flange Yoke		UJ626			(Continued)
H Yoke		UJ646			

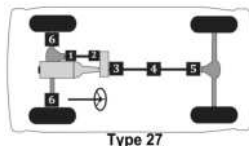
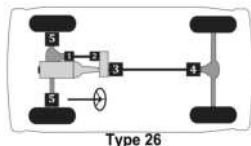

MFG./YEAR	MODEL & LOCATION	PART NO.	MFG./YEAR	MODEL & LOCATION	PART NO.
Drive Shaft (4 W/D) (Cont.)			Drive Shaft (4 W/D) (Cont.)		
U-Joint (Cont.)			U-Joint (Cont.)		
1988-1977 W200 & W250 w/ 2 Joint Rr Shaft, 2.625" Rr. Yoke & 1.188" Dia. Whl. Joint Brg. Caps: [Type 26]			1988-1977 W200 & W250 w/ 3 Joint Rr Shaft, 2.125" Rr. Yoke & 1.188" Dia. Whl. Joint Brg. Caps: [Type 27]		
U-Joint (Frt. Shaft; Frt.) ①		UJ315G	U-Joint (Frt. Shaft; Frt.) ①		UJ315G
Brute Force Greaseable		UJ246	Brute Force Greaseable		UJ246
Clamp Kit (Frt. Shaft; Frt.)		UJ318-10	Clamp Kit (Frt. Shaft; Frt.)		UJ318-10
U-Joint (Frt. Shaft; Rr.) ②	[2]	UJ534G	U-Joint (Frt. Shaft; Rr.) ②	[2]	UJ534G
Brute Force Greaseable		UJ235	Brute Force Greaseable		UJ235
Brute Force Non Greaseable		UJ234	Brute Force Non Greaseable		UJ234
U-Joint (Rr. Shaft; Frt.) ③		UJ315G	U-Joint (Rr. Shaft; Frt.) ③		UJ315G
Brute Force Greaseable		UJ246	Brute Force Greaseable		UJ246
Clamp Kit (Rr. Shaft; Frt.)		UJ318-10	Clamp Kit (Rr. Shaft; Frt.)		UJ318-10
U-Joint (Rr. Shaft; Rr.) ④		UJ316	U-Joint (Rr. Shaft; Rr.) ④		UJ316
Brute Force Greaseable		UJ248	Brute Force Greaseable		UJ248
Clamp Kit (Rr. Shaft; Rr.)		UJ316-10	Clamp Kit (Rr. Shaft; Rr.)		UJ316-10
U-Joint (Wheel Joint) ⑤	[2]	UJ371	U-Joint (Rr. Shaft; Rr.) ⑤		UJ315G
Brute Force Greaseable		UJ377	Brute Force Greaseable		UJ246
Brute Force Non Greaseable		UJ371	Clamp Kit (Rr. Shaft; Rr.)		UJ318-10
Ball Seat Repair Kit		UJ606	U-Joint (Wheel Joint) ⑥	[2]	UJ371
Flange Yoke		UJ626	Brute Force Greaseable		UJ377
H Yoke		UJ646	Brute Force Non Greaseable		UJ371
1988-1977 W200 & W250 w/ 2 Joint Rr Shaft, 2.625" Rr. Yoke & 1.375" Dia. Whl. Joint Brg. Caps: [Type 26]			Ball Seat Repair Kit		UJ606
U-Joint (Frt. Shaft; Frt.) ①		UJ315G	Flange Yoke		UJ626
Brute Force Greaseable		UJ246	H Yoke		UJ646
Clamp Kit (Frt. Shaft; Frt.)		UJ318-10	1988-1977 W200 & W250 w/ 3 Joint Rr Shaft, 2.125" Rr. Yoke & 1.375" Dia. Whl. Joint Brg. Caps: [Type 27]		
U-Joint (Frt. Shaft; Rr.) ②	[2]	UJ534G	U-Joint (Frt. Shaft; Frt.) ①		UJ315G
Brute Force Greaseable		UJ235	Brute Force Greaseable		UJ246
Brute Force Non Greaseable		UJ234	Clamp Kit (Frt. Shaft; Frt.)		UJ318-10
U-Joint (Rr. Shaft; Frt.) ③		UJ315G	U-Joint (Frt. Shaft; Rr.) ②	[2]	UJ534G
Brute Force Greaseable		UJ246	Brute Force Greaseable		UJ235
Clamp Kit (Rr. Shaft; Frt.)		UJ318-10	Brute Force Non Greaseable		UJ234
U-Joint (Rr. Shaft; Rr.) ④		UJ316	U-Joint (Rr. Shaft; Frt.) ③		UJ315G
Brute Force Greaseable		UJ248	Brute Force Greaseable		UJ246
Clamp Kit (Rr. Shaft; Rr.)		UJ316-10	Clamp Kit (Rr. Shaft; Frt.)		UJ318-10
U-Joint (Wheel Joint) ⑤	[2]	UJ374	U-Joint (Rr. Shaft; Ctr.) ④		UJ315G
Brute Force Non Greaseable		UJ374BF	Brute Force Greaseable		UJ246
Ball Seat Repair Kit		UJ606	Clamp Kit (Rr. Shaft; Ctr.)		UJ318-10
Flange Yoke		UJ626	U-Joint (Rr. Shaft; Rr.) ⑤		UJ315G
H Yoke		UJ646	Brute Force Greaseable		UJ246
			Clamp Kit (Rr. Shaft; Rr.)		UJ318-10
			U-Joint (Wheel Joint) ⑥	[2]	UJ374
			Brute Force Non Greaseable		UJ374BF
			Ball Seat Repair Kit		UJ606
			Flange Yoke		UJ626
			H Yoke		UJ646

(Continued)

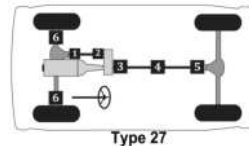
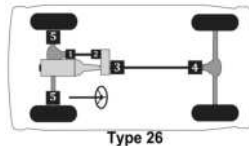

Passenger cars, light & medium trucks

Dodge Truck 3/4 ton -- (Cont.)

MFG./YEAR	MODEL & LOCATION	PART NO.	MFG./YEAR	MODEL & LOCATION	PART NO.
Drive Shaft (4 W/D) (Cont.)			Drive Shaft (4 W/D) (Cont.)		
U-Joint (Cont.)			U-Joint (Cont.)		
1988-1977 W200 & W250 w/ 3 Joint Rr Shaft, 2.625" Rr. Yoke & 1.375" Dia. Whl. Joint Brg. Caps: [Type 27]			1976-1975 W200 w/ Frt. Shaft Inner Lock Rings, 2 Joint Rr. Shaft & 2.125" Rr. Shaft Yoke: [Type 26]		
U-Joint (Frt. Shaft; Frt.)ⓐ		UJ315G	U-Joint (Frt. Shaft; Frt.)ⓐ		UJ315G
Brute Force Greaseable		UJ246	Brute Force Greaseable		UJ246
Clamp Kit (Frt. Shaft; Frt.)		UJ318-10	Clamp Kit (Frt. Shaft; Frt.)		UJ318-10
U-Joint (Frt. Shaft; Rr.)ⓑ	[2]	UJ534G	U-Joint (Frt. Shaft; Rr.)ⓑ	[2]	UJ534G
Brute Force Greaseable		UJ235	Brute Force Greaseable		UJ235
Brute Force Non Greaseable		UJ234	Brute Force Non Greaseable		UJ234
U-Joint (Rr. Shaft; Frt.)ⓐ		UJ315G	U-Joint (Rr. Shaft; Frt.)ⓐ		UJ315G
Brute Force Greaseable		UJ246	Brute Force Greaseable		UJ246
Clamp Kit (Rr. Shaft; Frt.)		UJ318-10	Clamp Kit (Rr. Shaft; Frt.)		UJ318-10
U-Joint (Rr. Shaft; Ctr.)ⓐ		UJ315G	U-Joint (Rr. Shaft; Rr.)ⓐ		UJ315G
Brute Force Greaseable		UJ246	Brute Force Greaseable		UJ246
Clamp Kit (Rr. Shaft; Ctr.)		UJ318-10	Clamp Kit (Rr. Shaft; Rr.)		UJ318-10
U-Joint (Rr. Shaft; Rr.)ⓐ		UJ316	U-Joint (Wheel Joint)ⓐ	[2]	UJ371
Brute Force Greaseable		UJ248	Brute Force Greaseable		UJ377
Clamp Kit (Rr. Shaft; Rr.)		UJ316-10	Brute Force Non Greaseable		UJ371
U-Joint (Wheel Joint)ⓐ	[2]	UJ374	Ball Seat Repair Kit		UJ606
Brute Force Non Greaseable		UJ374BF	Flange Yoke		UJ626
Ball Seat Repair Kit		UJ606	H Yoke		UJ646
Flange Yoke		UJ626			
H Yoke		UJ646			
1976-1975 W200 w/ Frt. Shaft Outer Lock Rings, 3 Joint Rr. Shaft & 2.625" Rr. Shaft Yoke: [Type 27]			1976-1975 W200 w/ Frt. Shaft Inner Lock Rings, 2 Joint Rr. Shaft & 2.625" Rr. Shaft Yoke: [Type 26]		
U-Joint (Frt. Shaft; Frt.)ⓐ		UJ315G	U-Joint (Frt. Shaft; Frt.)ⓐ		UJ315G
Brute Force Greaseable		UJ246	Brute Force Greaseable		UJ246
Clamp Kit (Frt. Shaft; Frt.)		UJ318-10	Clamp Kit (Frt. Shaft; Frt.)		UJ318-10
U-Joint (Frt. Shaft; Rr.)ⓑ	[2]	UJ379	U-Joint (Frt. Shaft; Rr.)ⓑ	[2]	UJ534G
Brute Force Greaseable		UJ280	Brute Force Greaseable		UJ235
Brute Force Non Greaseable		UJ269	Brute Force Non Greaseable		UJ234
U-Joint (Rr. Shaft; Frt.)ⓐ		UJ315G	U-Joint (Rr. Shaft; Frt.)ⓐ		UJ315G
Brute Force Greaseable		UJ246	Brute Force Greaseable		UJ246
Clamp Kit (Rr. Shaft; Frt.)		UJ318-10	Clamp Kit (Rr. Shaft; Frt.)		UJ318-10
U-Joint (Rr. Shaft; Ctr.)ⓐ		UJ315G	U-Joint (Rr. Shaft; Rr.)ⓐ		UJ316
Brute Force Greaseable		UJ246	Brute Force Greaseable		UJ248
Clamp Kit (Rr. Shaft; Ctr.)		UJ318-10	Clamp Kit (Rr. Shaft; Rr.)		UJ316-10
U-Joint (Rr. Shaft; Rr.)ⓐ		UJ316	U-Joint (Wheel Joint)ⓐ	[2]	UJ371
Brute Force Greaseable		UJ248	Brute Force Greaseable		UJ377
Clamp Kit (Rr. Shaft; Rr.)		UJ316-10	Brute Force Non Greaseable		UJ371
U-Joint (Wheel Joint)ⓐ	[2]	UJ371	Ball Seat Repair Kit		UJ606
Brute Force Greaseable		UJ377	Flange Yoke		UJ626
Brute Force Non Greaseable		UJ371	H Yoke		UJ646
Centering Yoke		UJ607			
H Yoke		UJ647			

(Continued)

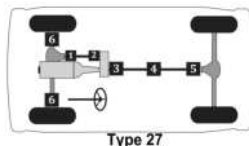
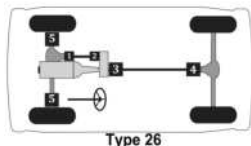

270 ▲ For Use w/ 1.063" Bearing Cap Application. ⓐ For Use w/ 1.188" Bearing Cap Application. ◇ For Use w/ Inner Lock Ring Application on Half Shaft. □ For Use w/ Outer Lock Ring Application on Half Shaft.

MFG./YEAR	MODEL & LOCATION	PART NO.	MFG./YEAR	MODEL & LOCATION	PART NO.
Drive Shaft (4 W/D) (Cont.)			Drive Shaft (4 W/D) (Cont.)		
U-Joint (Cont.)			U-Joint (Cont.)		
1976-1975 W200 w/ Frt. Shaft Inner Lock Rings, 3 Joint Rr. Shaft & 2.125" Rr. Shaft Yoke: [Type 27]			1976-1975 W200 w/ Frt. Shaft Outer Lock Rings, 2 Joint Rr. Shaft & 2.125" Rr. Shaft Yoke: [Type 26]		
U-Joint (Frt. Shaft; Frt.)		UJ315G	U-Joint (Frt. Shaft; Frt.)		UJ315G
Brute Force Greaseable		UJ246	Brute Force Greaseable		UJ246
Clamp Kit (Frt. Shaft; Frt.)		UJ318-10	Clamp Kit (Frt. Shaft; Frt.)		UJ318-10
U-Joint (Frt. Shaft; Rr.)	[2]	UJ534G	U-Joint (Frt. Shaft; Rr.)	[2]	UJ379
Brute Force Greaseable		UJ235	Brute Force Greaseable		UJ280
Brute Force Non Greaseable		UJ234	Brute Force Non Greaseable		UJ269
U-Joint (Rr. Shaft; Frt.)		UJ315G	U-Joint (Rr. Shaft; Frt.)		UJ315G
Brute Force Greaseable		UJ246	Brute Force Greaseable		UJ246
Clamp Kit (Rr. Shaft; Frt.)		UJ318-10	Clamp Kit (Rr. Shaft; Frt.)		UJ318-10
U-Joint (Rr. Shaft; Ctr.)		UJ315G	U-Joint (Rr. Shaft; Rr.)		UJ315G
Brute Force Greaseable		UJ246	Brute Force Greaseable		UJ246
Clamp Kit (Rr. Shaft; Ctr.)		UJ318-10	Clamp Kit (Rr. Shaft; Rr.)		UJ318-10
U-Joint (Rr. Shaft; Rr.)		UJ315G	U-Joint (Wheel Joint)	[2]	UJ371
Brute Force Greaseable		UJ246	Brute Force Greaseable		UJ377
Clamp Kit (Rr. Shaft; Rr.)		UJ318-10	Brute Force Non Greaseable		UJ371
U-Joint (Wheel Joint)	[2]	UJ371	Centering Yoke		UJ607
Brute Force Greaseable		UJ377	H Yoke		UJ647
Brute Force Non Greaseable		UJ371	1976-1975 W200 w/ Frt. Shaft Outer Lock Rings, 2 Joint Rr. Shaft & 2.625" Rr. Shaft Yoke: [Type 26]		
Ball Seat Repair Kit		UJ606	U-Joint (Frt. Shaft; Frt.)		UJ315G
Flange Yoke		UJ626	Brute Force Greaseable		UJ246
H Yoke		UJ646	Clamp Kit (Frt. Shaft; Frt.)		UJ318-10
1976-1975 W200 w/ Frt. Shaft Inner Lock Rings, 3 Joint Rr. Shaft & 2.625" Rr. Shaft Yoke: [Type 27]			U-Joint (Frt. Shaft; Rr.)	[2]	UJ379
U-Joint (Frt. Shaft; Frt.)		UJ315G	Brute Force Greaseable		UJ280
Brute Force Greaseable		UJ246	Brute Force Non Greaseable		UJ269
Clamp Kit (Frt. Shaft; Frt.)		UJ318-10	U-Joint (Rr. Shaft; Frt.)		UJ315G
U-Joint (Frt. Shaft; Rr.)	[2]	UJ534G	Brute Force Greaseable		UJ246
Brute Force Greaseable		UJ235	Clamp Kit (Rr. Shaft; Frt.)		UJ318-10
Brute Force Non Greaseable		UJ234	U-Joint (Rr. Shaft; Rr.)		UJ316
U-Joint (Rr. Shaft; Frt.)		UJ315G	Brute Force Greaseable		UJ248
Brute Force Greaseable		UJ246	Clamp Kit (Rr. Shaft; Rr.)		UJ316-10
Clamp Kit (Rr. Shaft; Frt.)		UJ318-10	U-Joint (Wheel Joint)	[2]	UJ371
U-Joint (Rr. Shaft; Ctr.)		UJ315G	Brute Force Greaseable		UJ377
Brute Force Greaseable		UJ246	Brute Force Non Greaseable		UJ371
Clamp Kit (Rr. Shaft; Ctr.)		UJ318-10	Centering Yoke		UJ607
U-Joint (Rr. Shaft; Rr.)		UJ316	H Yoke		UJ647
Brute Force Greaseable		UJ248	(Continued)		
Clamp Kit (Rr. Shaft; Rr.)		UJ316-10			
U-Joint (Wheel Joint)	[2]	UJ371			
Brute Force Greaseable		UJ377			
Brute Force Non Greaseable		UJ371			
Ball Seat Repair Kit		UJ606			
Flange Yoke		UJ626			
H Yoke		UJ646			

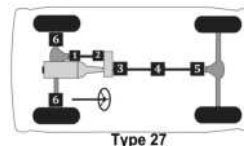
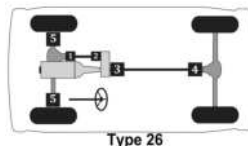

Passenger cars, light & medium trucks

Dodge Truck 3/4 ton -- (Cont.)

MFG./YEAR	MODEL & LOCATION	PART NO.	MFG./YEAR	MODEL & LOCATION	PART NO.
Drive Shaft (4 W/D) (Cont.)			Drive Shaft (4 W/D) (Cont.)		
U-Joint (Cont.)			U-Joint (Cont.)		
1976-1975 W200 w/ Frt. Shaft Outer Lock Rings, 3 Joint Rr. Shaft & 2.125" Rr. Shaft Yoke: [Type 27]			1971-1968 W200 w/ Inner Lock Ring Whl. Joints:		
[Type 27]			[Type 34]		
U-Joint (Frt. Shaft; Frt.)ⓐ		UJ315G	U-Joint (Frt. Shaft; Frt.)ⓐ		UJ315G
Brute Force Greaseable		UJ246	Brute Force Greaseable		UJ246
Clamp Kit (Frt. Shaft; Frt.)		UJ318-10	Clamp Kit (Frt. Shaft; Frt.)		UJ318-10
U-Joint (Frt. Shaft; Rr.)ⓑ	[2]	UJ379	U-Joint (Frt. Shaft; Rr.)ⓑ		UJ315G
Brute Force Greaseable		UJ280	Brute Force Greaseable		UJ246
Brute Force Non Greaseable		UJ269	Clamp Kit (Frt. Shaft; Rr.)		UJ318-10
U-Joint (Rr. Shaft; Frt.)ⓐ		UJ315G	U-Joint (Intmd. Shaft; Frt.)ⓐ		UJ315G
Brute Force Greaseable		UJ246	Brute Force Greaseable		UJ246
Clamp Kit (Rr. Shaft; Frt.)		UJ318-10	Clamp Kit (Intmd. Shaft; Frt.)		UJ318-10
U-Joint (Rr. Shaft; Ctr.)ⓐ		UJ315G	U-Joint (Intmd. Shaft; Rr.)ⓐ		UJ315G
Brute Force Greaseable		UJ246	Brute Force Greaseable		UJ246
Clamp Kit (Rr. Shaft; Ctr.)		UJ318-10	Clamp Kit (Intmd. Shaft; Rr.)		UJ318-10
U-Joint (Rr. Shaft; Rr.)ⓐ		UJ315G	U-Joint (Rr. Shaft; Frt.)ⓐ		UJ315G
Brute Force Greaseable		UJ246	Brute Force Greaseable		UJ246
Clamp Kit (Rr. Shaft; Rr.)		UJ318-10	Clamp Kit (Rr. Shaft; Frt.)		UJ318-10
U-Joint (Wheel Joint)ⓐ	[2]	UJ371	U-Joint (Rr. Shaft; Rr.)ⓐ		UJ315G
Brute Force Greaseable		UJ377	Brute Force Greaseable		UJ246
Brute Force Non Greaseable		UJ371	Clamp Kit (Rr. Shaft; Rr.)		UJ318-10
Centering Yoke		UJ607	U-Joint (Wheel Joint)ⓐ	[2]	UJ365
H Yoke		UJ647	Brute Force Greaseable		UJ378
1974-1972 W200: [Type 34]			Brute Force Non Greaseable		UJ365
U-Joint (Frt. Shaft; Frt.)ⓐ		UJ315G	U-Joint (PTO)		UJ338
Brute Force Greaseable		UJ246	1971-1968 W200 w/ Outer Lock Ring Whl. Joints:		
Clamp Kit (Frt. Shaft; Frt.)		UJ318-10	[Type 34]		
U-Joint (Frt. Shaft; Rr.)ⓑ		UJ315G	U-Joint (Frt. Shaft; Frt.)ⓐ		UJ315G
Brute Force Greaseable		UJ246	Brute Force Greaseable		UJ246
Clamp Kit (Frt. Shaft; Rr.)		UJ318-10	Clamp Kit (Frt. Shaft; Frt.)		UJ318-10
U-Joint (Intmd. Shaft; Frt.)ⓐ		UJ315G	U-Joint (Frt. Shaft; Rr.)ⓑ		UJ315G
Brute Force Greaseable		UJ246	Brute Force Greaseable		UJ246
Clamp Kit (Intmd. Shaft; Frt.)		UJ318-10	Clamp Kit (Frt. Shaft; Rr.)		UJ318-10
U-Joint (Intmd. Shaft; Rr.)ⓐ		UJ315G	U-Joint (Intmd. Shaft; Frt.)ⓐ		UJ315G
Brute Force Greaseable		UJ246	Brute Force Greaseable		UJ246
Clamp Kit (Intmd. Shaft; Rr.)		UJ318-10	Clamp Kit (Intmd. Shaft; Frt.)		UJ318-10
U-Joint (Rr. Shaft; Frt.)ⓐ		UJ315G	U-Joint (Intmd. Shaft; Rr.)ⓐ		UJ315G
Brute Force Greaseable		UJ246	Brute Force Greaseable		UJ246
Clamp Kit (Rr. Shaft; Frt.)		UJ318-10	Clamp Kit (Intmd. Shaft; Rr.)		UJ318-10
U-Joint (Rr. Shaft; Rr.)ⓐ		UJ315G	U-Joint (Rr. Shaft; Frt.)ⓐ		UJ315G
Brute Force Greaseable		UJ246	Brute Force Greaseable		UJ246
Clamp Kit (Rr. Shaft; Rr.)		UJ318-10	Clamp Kit (Rr. Shaft; Frt.)		UJ318-10
U-Joint (Wheel Joint)ⓐ	[2]	UJ371	U-Joint (Rr. Shaft; Rr.)ⓐ		UJ315G
Brute Force Greaseable		UJ377	Brute Force Greaseable		UJ246
Brute Force Non Greaseable		UJ371	Clamp Kit (Rr. Shaft; Rr.)		UJ318-10
U-Joint (PTO)		UJ338	U-Joint (Wheel Joint)ⓐ	[2]	UJ231
			(For Aluminum Drive Shaft)		UJ231C
			U-Joint (PTO)		UJ338

(Continued)

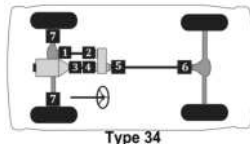
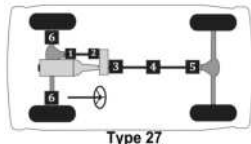

272 ▲ For Use w/ 1.063" Bearing Cap Application. ⓐ For Use w/ 1.188" Bearing Cap Application. ◇ For Use w/ Inner Lock Ring Application on Half Shaft. □ For Use w/ Outer Lock Ring Application on Half Shaft.



MFG./YEAR	MODEL & LOCATION	PART NO.	MFG./YEAR	MODEL & LOCATION	PART NO.
Drive Shaft (4 W/D) (Cont.)			Drive Shaft (4 W/D) (Cont.)		
U-Joint (Cont.)			U-Joint (Cont.)		
1967-1961 W200 w/ 2.125" Yokes & Outer Lock			1967-1961 W200 w/ 2.125" Yokes & Inner Lock		
Ring Whl. Joints: [Type 34]			Ring Whl. Joints: [Type 34]		
U-Joint (Frnt. Shaft; Frnt.) ^①		UJ315G	U-Joint (Frnt. Shaft; Frnt.) ^①		UJ315G
Brute Force Greaseable		UJ246	Brute Force Greaseable		UJ246
Clamp Kit (Frnt. Shaft; Frnt.)		UJ318-10	Clamp Kit (Frnt. Shaft; Frnt.)		UJ318-10
U-Joint (Frnt. Shaft; Rr.) ^②		UJ315G	U-Joint (Frnt. Shaft; Rr.) ^②		UJ315G
Brute Force Greaseable		UJ246	Brute Force Greaseable		UJ246
Clamp Kit (Frnt. Shaft; Rr.)		UJ318-10	Clamp Kit (Frnt. Shaft; Rr.)		UJ318-10
U-Joint (Intmd. Shaft; Frnt.) ^③		UJ315G	U-Joint (Intmd. Shaft; Frnt.) ^③		UJ315G
Brute Force Greaseable		UJ246	Brute Force Greaseable		UJ246
Clamp Kit (Intmd. Shaft; Frnt.)		UJ318-10	Clamp Kit (Intmd. Shaft; Frnt.)		UJ318-10
U-Joint (Intmd. Shaft; Rr.) ^④		UJ315G	U-Joint (Intmd. Shaft; Rr.) ^④		UJ315G
Brute Force Greaseable		UJ246	Brute Force Greaseable		UJ246
Clamp Kit (Intmd. Shaft; Rr.)		UJ318-10	Clamp Kit (Intmd. Shaft; Rr.)		UJ318-10
U-Joint (Rr. Shaft; Frnt.) ^⑤		UJ315G	U-Joint (Rr. Shaft; Frnt.) ^⑤		UJ315G
Brute Force Greaseable		UJ246	Brute Force Greaseable		UJ246
Clamp Kit (Rr. Shaft; Frnt.)		UJ318-10	Clamp Kit (Rr. Shaft; Frnt.)		UJ318-10
U-Joint (Rr. Shaft; Rr.) ^⑥		UJ315G	U-Joint (Rr. Shaft; Rr.) ^⑥		UJ315G
Brute Force Greaseable		UJ246	Brute Force Greaseable		UJ246
Clamp Kit (Rr. Shaft; Rr.)		UJ318-10	Clamp Kit (Rr. Shaft; Rr.)		UJ318-10
U-Joint (Wheel Joint) ^⑦	[2]	UJ231	U-Joint (Wheel Joint) ^⑦	[2]	UJ231
(For Aluminum Drive Shaft)		UJ231C	Brute Force Greaseable		UJ378
U-Joint (PTO)		UJ338	Brute Force Non Greaseable		UJ365
			U-Joint (PTO)		UJ338
			1967-1961 W200 w/ 3" Yokes & Outer Lock Ring		
			Whl. Joints: [Type 34]		
			U-Joint (Frnt. Shaft; Frnt.) ^①		UJ304
			U-Joint (Frnt. Shaft; Rr.) ^②		UJ304
			U-Joint (Intmd. Shaft; Frnt.) ^③		UJ304
			U-Joint (Intmd. Shaft; Rr.) ^④		UJ304
			U-Joint (Rr. Shaft; Frnt.) ^⑤		UJ304
			U-Joint (Rr. Shaft; Rr.) ^⑥		UJ304
			U-Joint (Wheel Joint) ^⑦	[2]	UJ231
			(For Aluminum Drive Shaft)		UJ231C
			U-Joint (PTO)		UJ338
			1967-1961 W200 w/ 3" Yokes & Inner Lock Ring		
			Whl. Joints: [Type 34]		
			U-Joint (Frnt. Shaft; Frnt.) ^①		UJ304
			U-Joint (Frnt. Shaft; Rr.) ^②		UJ304
			U-Joint (Intmd. Shaft; Frnt.) ^③		UJ304
			U-Joint (Intmd. Shaft; Rr.) ^④		UJ304
			U-Joint (Rr. Shaft; Frnt.) ^⑤		UJ304
			U-Joint (Rr. Shaft; Rr.) ^⑥		UJ304
			U-Joint (Wheel Joint) ^⑦	[2]	UJ365
			Brute Force Greaseable		UJ378
			Brute Force Non Greaseable		UJ365
			U-Joint (PTO)		UJ338

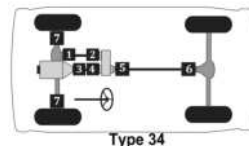

Passenger cars, light & medium trucks

Dodge Truck 1 ton

MFG./YEAR	MODEL & LOCATION	PART NO.	MFG./YEAR	MODEL & LOCATION	PART NO.
Drive Shaft (2 W/D)			Drive Shaft (2 W/D) (Cont.)		
U-Joint			U-Joint (Cont.)		
2010	R3500 Cab & Chassis: [Type 2]		2009	R3500 Cab & Chassis w/ Diesel Eng.: [Type 2]	
U-Joint (Front)Ⓛ	UJ358A	U-Joint (Front)Ⓛ	UJ358A
Brute Force Non Greaseable	UJ358ABF	Brute Force Non Greaseable	UJ358ABF
U-Joint (Center)Ⓢ	UJ358A	U-Joint (Center)Ⓢ	UJ358A
Brute Force Non Greaseable	UJ358ABF	Brute Force Non Greaseable	UJ358ABF
U-Joint (Rear)Ⓢ	UJ358A	U-Joint (Rear)Ⓢ	UJ358A
Brute Force Non Greaseable	UJ358ABF	Brute Force Non Greaseable	UJ358ABF
2010-2009	R3500 w/ 2 Joint Shaft & 1.188" Dia. Brg. Cap Exc. Cab & Chassis: [Type 1]		2008-2007	R3500 w/ 2 Joint Shaft & Gas Eng. Exc. Cab & Chassis: [Type 1]	
U-Joint (Front)Ⓛ	UJ330A	U-Joint (Front)Ⓛ	UJ330A
Brute Force Greaseable	UJ295A	Brute Force Greaseable	UJ295A
U-Joint (Rear)Ⓢ	UJ330A	U-Joint (Rear)Ⓢ	UJ330A
Brute Force Greaseable	UJ295A	Brute Force Greaseable	UJ295A
2010-2009	R3500 w/ 2 Joint Shaft & 1.375" Dia. Brg. Cap Exc. Cab & Chassis: [Type 1]		2008-2007	R3500 w/ 2 Joint Shaft & Diesel Eng. Exc. Cab & Chassis: [Type 1]	
U-Joint (Front)Ⓛ	UJ351A	U-Joint (Front)Ⓛ	UJ351A
Brute Force Non Greaseable	UJ351ABF	Brute Force Non Greaseable	UJ351ABF
U-Joint (Rear)Ⓢ	UJ351A	U-Joint (Rear)Ⓢ	UJ351A
Brute Force Non Greaseable	UJ351ABF	Brute Force Non Greaseable	UJ351ABF
2010-2009	R3500 w/ 3 Joint Shaft & 1.188" Dia. Brg. Cap Exc. Cab & Chassis: [Type 2]		2008-2007	R3500 w/ 3 Joint Shaft & Gas Eng. Exc. Cab & Chassis: [Type 2]	
U-Joint (Front)Ⓛ	UJ330A	U-Joint (Front)Ⓛ	UJ330A
Brute Force Greaseable	UJ295A	Brute Force Greaseable	UJ295A
U-Joint (Center)Ⓢ	UJ330A	U-Joint (Center)Ⓢ	UJ330A
Brute Force Greaseable	UJ295A	Brute Force Greaseable	UJ295A
U-Joint (Rear)Ⓢ	UJ330A	U-Joint (Rear)Ⓢ	UJ330A
Brute Force Greaseable	UJ295A	Brute Force Greaseable	UJ295A
2010-2009	R3500 w/ 3 Joint Shaft & 1.375" Dia. Brg. Cap Exc. Cab & Chassis: [Type 2]		2008-2007	R3500 w/ 3 Joint Shaft & Diesel Eng. Exc. Cab & Chassis: [Type 2]	
U-Joint (Front)Ⓛ	UJ351A	U-Joint (Front)Ⓛ	UJ351A
Brute Force Non Greaseable	UJ351ABF	Brute Force Non Greaseable	UJ351ABF
U-Joint (Center)Ⓢ	UJ351A	U-Joint (Center)Ⓢ	UJ351A
Brute Force Non Greaseable	UJ351ABF	Brute Force Non Greaseable	UJ351ABF
U-Joint (Rear)Ⓢ	UJ351A	U-Joint (Rear)Ⓢ	UJ351A
Brute Force Non Greaseable	UJ351ABF	Brute Force Non Greaseable	UJ351ABF
2009	R3500 Cab & Chassis w/ Gas Eng.: [Type 2]		2008-2007	R3500 Cab & Chassis w/ Gas Eng. & Auto. Trans.: [Type 2]	
U-Joint (Front)Ⓛ	UJ330A	U-Joint (Front)Ⓛ	UJ351A
Brute Force Greaseable	UJ295A	Brute Force Non Greaseable	UJ351ABF
U-Joint (Center)Ⓢ	UJ330A	U-Joint (Center)Ⓢ	UJ351A
Brute Force Greaseable	UJ295A	Brute Force Non Greaseable	UJ351ABF
U-Joint (Rear)Ⓢ	UJ330A	U-Joint (Rear)Ⓢ	UJ351A
Brute Force Greaseable	UJ295A	Brute Force Non Greaseable	UJ351ABF

(Continued)

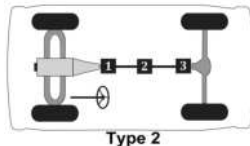
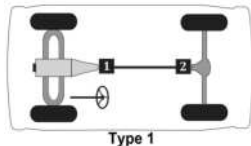

274 ▲ For Use w/ 1.063" Bearing Cap Application. ○ For Use w/ 1.188" Bearing Cap Application. ◇ For Use w/ Inner Lock Ring Application on Half Shaft. □ For Use w/ Outer Lock Ring Application on Half Shaft.



MFG./YEAR	MODEL & LOCATION	PART NO.	MFG./YEAR	MODEL & LOCATION	PART NO.
Drive Shaft (2 W/D) (Cont.)			Drive Shaft (2 W/D) (Cont.)		
U-Joint (Cont.)			U-Joint (Cont.)		
2008-2007 R3500 Cab & Chassis w/ Gas Eng. & Man. Trans.: [Type 2]			2002-1997 R3500 w/ 2 Joint Shaft: [Type 1]		
U-Joint (Front)Ⓢ		UJ358A	U-Joint (Front)Ⓢ		UJ330
Brute Force Non Greaseable		UJ358ABF	Brute Force Greaseable		UJ295
U-Joint (Center)Ⓢ		UJ358A	(For Aluminum Drive Shaft)		UJ330C
Brute Force Non Greaseable		UJ358ABF	Clamp Kit (Front)		UJ331-10
U-Joint (Rear)Ⓢ		UJ358A	U-Joint (Rear)Ⓢ		UJ330
Brute Force Non Greaseable		UJ358ABF	Brute Force Greaseable		UJ295
2008-2007 R3500 Cab & Chassis w/ Diesel Eng.: [Type 2]			(For Aluminum Drive Shaft)		
U-Joint (Front)Ⓢ		UJ358A	U-Joint (Front)Ⓢ		UJ330
Brute Force Non Greaseable		UJ358ABF	Brute Force Greaseable		UJ295
U-Joint (Center)Ⓢ		UJ358A	(For Aluminum Drive Shaft)		UJ330C
Brute Force Non Greaseable		UJ358ABF	Clamp Kit (Front)		UJ331-10
U-Joint (Rear)Ⓢ		UJ358A	U-Joint (Center)Ⓢ		UJ330
Brute Force Non Greaseable		UJ358ABF	Brute Force Greaseable		UJ295
2006-2004 R3500 w/ 2 Joint Shaft & 1.188" Dia. Brg. Cap: [Type 1]			(For Aluminum Drive Shaft)		
U-Joint (Front)Ⓢ		UJ330A	U-Joint (Rear)Ⓢ		UJ330
Brute Force Greaseable		UJ295A	Brute Force Greaseable		UJ295
U-Joint (Rear)Ⓢ		UJ330A	(For Aluminum Drive Shaft)		UJ330C
Brute Force Greaseable		UJ295A	Clamp Kit (Rear)		UJ331-10
2006-2004 R3500 w/ 3 Joint Shaft & 1.188" Dia. Brg. Cap: [Type 2]			1996-1990 D350 & R3500 w/ 2 Joint Shaft & 8 Cyl. Eng.: [Type 1]		
U-Joint (Front)Ⓢ		UJ330A	U-Joint (Front)Ⓢ		UJ316
Brute Force Greaseable		UJ295A	Brute Force Greaseable		UJ248
U-Joint (Center)Ⓢ		UJ330A	Clamp Kit (Front)		UJ316-10
Brute Force Greaseable		UJ295A	U-Joint (Rear)Ⓢ		UJ316
U-Joint (Rear)Ⓢ		UJ330A	Brute Force Greaseable		UJ248
Brute Force Greaseable		UJ295A	Clamp Kit (Rear)		UJ316-10
2006-2004 R3500 w/ 3 Joint Shaft & 1.375" Dia. Brg. Cap: [Type 2]			1996-1990 D350 & R3500 w/ 3 Joint Shaft & 8 Cyl. Eng.: [Type 2]		
U-Joint (Front)Ⓢ		UJ351A	U-Joint (Front)Ⓢ		UJ316
Brute Force Non Greaseable		UJ351ABF	Brute Force Greaseable		UJ248
U-Joint (Center)Ⓢ		UJ351A	Clamp Kit (Front)		UJ316-10
Brute Force Non Greaseable		UJ351ABF	U-Joint (Center)Ⓢ		UJ316
U-Joint (Rear)Ⓢ		UJ351A	Brute Force Greaseable		UJ248
Brute Force Non Greaseable		UJ351ABF	Clamp Kit (Center)		UJ316-10
2003 R3500 w/ 2 Joint Shaft: [Type 1]			U-Joint (Rear)Ⓢ		
U-Joint (Front)Ⓢ		UJ330A			UJ316
Brute Force Greaseable		UJ295A	Brute Force Greaseable		UJ248
U-Joint (Rear)Ⓢ		UJ330A	Clamp Kit (Rear)		UJ316-10
Brute Force Greaseable		UJ295A	1996-1989 D350 & R3500 w/ 2 Joint Shaft, Diesel & 10 Cyl. Eng.s.: [Type 1]		
2003 R3500 w/ 3 Joint Shaft: [Type 2]			U-Joint (Front)Ⓢ		
U-Joint (Front)Ⓢ		UJ330A			UJ330
Brute Force Greaseable		UJ295A	Brute Force Greaseable		UJ295
U-Joint (Center)Ⓢ		UJ330A	(For Aluminum Drive Shaft)		UJ330C
Brute Force Greaseable		UJ295A	Clamp Kit (Front)		UJ331-10
U-Joint (Rear)Ⓢ		UJ330A	U-Joint (Rear)Ⓢ		UJ330
Brute Force Greaseable		UJ295A	Brute Force Greaseable		UJ295
			(For Aluminum Drive Shaft)		UJ330C
			Clamp Kit (Rear)		UJ331-10

(Continued)

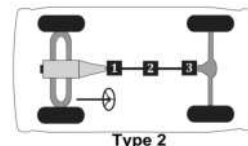
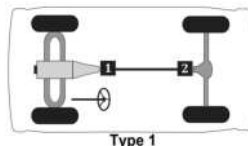

Passenger cars, light & medium trucks

Dodge Truck 1 ton -- (Cont.)

MFG./YEAR	MODEL & LOCATION	PART NO.	MFG./YEAR	MODEL & LOCATION	PART NO.
Drive Shaft (2 W/D) (Cont.)			Drive Shaft (2 W/D) (Cont.)		
U-Joint (Cont.)			U-Joint (Cont.)		
1996-1989 D350 & R3500 w/ 3 Joint Shaft, Diesel & 10 Cyl. Eng.s.: [Type 2]			1981-1972 D300 & D350 w/ 2 Joint Shaft & 2.125" Yoke: [Type 1]		
U-Joint (Front)Ⓛ		UJ330	U-Joint (Front)Ⓛ		UJ315G
Brute Force Greaseable		UJ295	Brute Force Greaseable		UJ246
(For Aluminum Drive Shaft)		UJ330C	Clamp Kit		UJ318-10
Clamp Kit (Front)		UJ331-10	U-Joint (Rear)Ⓞ		UJ315G
U-Joint (Center)Ⓞ		UJ330	Brute Force Greaseable		UJ246
Brute Force Greaseable		UJ295	Clamp Kit		UJ318-10
(For Aluminum Drive Shaft)		UJ330C	1981-1972 D300 & D350 w/ 3 Joint Shaft & 2.125" Yoke: [Type 2]		
Clamp Kit (Center)		UJ331-10	U-Joint (Front)Ⓛ		UJ315G
U-Joint (Rear)Ⓞ		UJ330	Brute Force Greaseable		UJ246
Brute Force Greaseable		UJ295	Clamp Kit		UJ318-10
(For Aluminum Drive Shaft)		UJ330C	U-Joint (Center)Ⓞ		UJ315G
Clamp Kit (Rear)		UJ331-10	Brute Force Greaseable		UJ246
1989 D350 w/ 2 Joint Shaft & Gas Eng.: [Type 1]			Clamp Kit		UJ318-10
U-Joint (Front)Ⓛ		UJ317	U-Joint (Rear)Ⓞ		UJ315G
Brute Force Greaseable		UJ246	Brute Force Greaseable		UJ246
Clamp Kit (Front)		UJ318-10	Clamp Kit		UJ318-10
U-Joint (Rear)Ⓞ		UJ317	1981-1972 D300 & D350 w/ 2 Joint Shaft & 2.625" Yoke: [Type 1]		
Brute Force Greaseable		UJ246	U-Joint (Front)Ⓛ		UJ316
Clamp Kit (Rear)		UJ318-10	Brute Force Greaseable		UJ248
1989 D350 w/ 3 Joint Shaft & Gas Eng.: [Type 2]			Clamp Kit (Front)		UJ316-10
U-Joint (Front)Ⓛ		UJ317	U-Joint (Rear)Ⓞ		UJ316
Brute Force Greaseable		UJ246	Brute Force Greaseable		UJ248
Clamp Kit (Front)		UJ318-10	Clamp Kit (Rear)		UJ316-10
U-Joint (Center)Ⓞ		UJ317	1981-1972 D300 & D350 w/ 3 Joint Shaft & 2.625" Yoke: [Type 2]		
Brute Force Greaseable		UJ246	U-Joint (Front)Ⓛ		UJ316
Clamp Kit (Center)		UJ318-10	Brute Force Greaseable		UJ248
U-Joint (Rear)Ⓞ		UJ317	Clamp Kit (Front)		UJ316-10
Brute Force Greaseable		UJ246	U-Joint (Center)Ⓞ		UJ316
Clamp Kit (Rear)		UJ318-10	Brute Force Greaseable		UJ248
1988-1982 D350 w/ 2 Joint Shaft: [Type 1]			Clamp Kit (Center)		UJ316-10
U-Joint (Front)Ⓛ		UJ315G	U-Joint (Rear)Ⓞ		UJ316
Brute Force Greaseable		UJ246	Brute Force Greaseable		UJ248
Clamp Kit		UJ318-10	Clamp Kit (Rear)		UJ316-10
U-Joint (Rear)Ⓞ		UJ315G	1971-1961 D300 w/ 2 Joint Shaft: [Type 1]		
Brute Force Greaseable		UJ246	U-Joint (Front)Ⓛ		UJ315G
Clamp Kit		UJ318-10	Brute Force Greaseable		UJ246
1988-1982 D350 w/ 3 Joint Shaft: [Type 2]			Clamp Kit		UJ318-10
U-Joint (Front)Ⓛ		UJ315G	U-Joint (Rear)Ⓞ		UJ315G
Brute Force Greaseable		UJ246	Brute Force Greaseable		UJ246
Clamp Kit		UJ318-10	Clamp Kit		UJ318-10
U-Joint (Center)Ⓞ		UJ315G	1988-1982 D350 w/ 3 Joint Shaft: [Type 2]		
Brute Force Greaseable		UJ246	U-Joint (Front)Ⓛ		UJ315G
Clamp Kit		UJ318-10	Brute Force Greaseable		UJ246
U-Joint (Rear)Ⓞ		UJ315G	Clamp Kit		UJ318-10
Brute Force Greaseable		UJ246	1988-1982 D350 w/ 3 Joint Shaft: [Type 2]		
Clamp Kit		UJ318-10	U-Joint (Front)Ⓛ		UJ315G
			Brute Force Greaseable		UJ246
			Clamp Kit		UJ318-10
			U-Joint (Rear)Ⓞ		UJ315G
			Brute Force Greaseable		UJ246
			Clamp Kit		UJ318-10

(Continued)

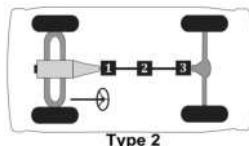
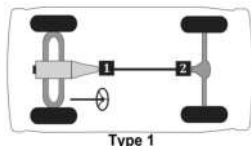

MFG./YEAR	MODEL & LOCATION	PART NO.	MFG./YEAR	MODEL & LOCATION	PART NO.
Drive Shaft (2 W/D) (Cont.)			Drive Shaft (4 W/D) (Cont.)		
U-Joint (Cont.)			U-Joint (Cont.)		
1971-1961 D300 w/ 3 Joint Shaft: [Type 2]			2010 R3500 w/ 3 Joint Rr. Shaft & Single Rr. Whls.: [Type 27]		
U-Joint (Front)ⓐ		UJ315G	U-Joint (Fr. Shaft; Frt.)ⓐ		UJ331
Brute Force Greaseable		UJ246	Brute Force Greaseable		UJ232
Clamp Kit		UJ318-10	Brute Force Non Greaseable		UJ231
U-Joint (Center)ⓐ		UJ315G	(For Aluminum Drive Shaft)		UJ331C
Brute Force Greaseable		UJ246	U-Joint (Fr. Shaft; Rr.)ⓐ	[2]	UJ331
Clamp Kit		UJ318-10	Brute Force Greaseable		UJ232
U-Joint (Rear)ⓐ		UJ315G	Brute Force Non Greaseable		UJ231
Brute Force Greaseable		UJ246	(For Aluminum Drive Shaft)		UJ331C
Clamp Kit		UJ318-10	U-Joint (Rr. Shaft; Frt.)ⓐ		UJ351A
			Brute Force Non Greaseable		UJ351ABF
			U-Joint (Rr. Shaft; Ctr.)ⓐ		UJ351A
			Brute Force Non Greaseable		UJ351ABF
			U-Joint (Rr. Shaft; Rr.)ⓐ		UJ351A
			Brute Force Non Greaseable		UJ351ABF
			U-Joint (Wheel Joint)ⓐ	[2]	UJ479
			Centering Ball Kit		UJ617
			H Yoke		UJ650
			2010 R3500 w/ 3 Joint Rr. Shaft & Dual Rr. Whls.: [Type 27]		
			U-Joint (Fr. Shaft; Frt.)ⓐ		UJ331
			Brute Force Greaseable		UJ232
			Brute Force Non Greaseable		UJ231
			(For Aluminum Drive Shaft)		UJ331C
			U-Joint (Fr. Shaft; Rr.)ⓐ	[2]	UJ331
			Brute Force Greaseable		UJ232
			Brute Force Non Greaseable		UJ231
			(For Aluminum Drive Shaft)		UJ331C
			U-Joint (Rr. Shaft; Frt.)ⓐ		UJ358A
			Brute Force Non Greaseable		UJ358ABF
			U-Joint (Rr. Shaft; Ctr.)ⓐ		UJ358A
			Brute Force Non Greaseable		UJ358ABF
			U-Joint (Rr. Shaft; Rr.)ⓐ		UJ358A
			Brute Force Non Greaseable		UJ358ABF
			U-Joint (Wheel Joint)ⓐ	[2]	UJ479
			Centering Ball Kit		UJ617
			H Yoke		UJ650
					(Continued)
Drive Shaft (4 W/D)					
U-Joint					
2010 R3500 w/ 2 Joint Rr. Shaft & Dual Rr. Whls.: [Type 26]					
U-Joint (Fr. Shaft; Frt.)ⓐ		UJ331			
Brute Force Greaseable		UJ232			
Brute Force Non Greaseable		UJ231			
(For Aluminum Drive Shaft)		UJ331C			
U-Joint (Fr. Shaft; Rr.)ⓐ	[2]	UJ331			
Brute Force Greaseable		UJ232			
Brute Force Non Greaseable		UJ231			
(For Aluminum Drive Shaft)		UJ331C			
U-Joint (Rr. Shaft; Frt.)ⓐ		UJ358A			
Brute Force Non Greaseable		UJ358ABF			
U-Joint (Rr. Shaft; Rr.)ⓐ		UJ358A			
Brute Force Non Greaseable		UJ358ABF			
U-Joint (Wheel Joint)ⓐ	[2]	UJ479			
Centering Ball Kit		UJ617			
H Yoke		UJ650			
2010 R3500 w/ 2 Joint Rr. Shaft & Single Rr. Whls.: [Type 26]					
U-Joint (Fr. Shaft; Frt.)ⓐ		UJ331			
Brute Force Greaseable		UJ232			
Brute Force Non Greaseable		UJ231			
(For Aluminum Drive Shaft)		UJ331C			
U-Joint (Fr. Shaft; Rr.)ⓐ	[2]	UJ331			
Brute Force Greaseable		UJ232			
Brute Force Non Greaseable		UJ231			
(For Aluminum Drive Shaft)		UJ331C			
U-Joint (Rr. Shaft; Frt.)ⓐ		UJ351A			
Brute Force Non Greaseable		UJ351ABF			
U-Joint (Rr. Shaft; Rr.)ⓐ		UJ351A			
Brute Force Non Greaseable		UJ351ABF			
U-Joint (Wheel Joint)ⓐ	[2]	UJ479			
Centering Ball Kit		UJ617			
H Yoke		UJ650			

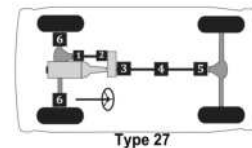
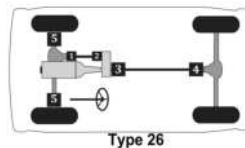
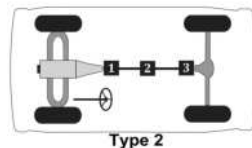

Passenger cars, light & medium trucks

Dodge Truck 1 ton -- (Cont.)

MFG./YEAR	MODEL & LOCATION	PART NO.	MFG./YEAR	MODEL & LOCATION	PART NO.
Drive Shaft (4 W/D) (Cont.)			Drive Shaft (4 W/D) (Cont.)		
U-Joint (Cont.)			U-Joint (Cont.)		
2010	R3500 Cab & Chassis w/ 2 Joint Rr. Shaft: [Type 26]		2010	R3500 Cab & Chassis w/ 3 Joint Rr. Shaft & Single Rr. Whls.: [Type 27]	
	U-Joint (Fr. Shaft; Frt.) [⊙]	UJ331		U-Joint (Fr. Shaft; Frt.) [⊙]	UJ331
	Brute Force Greaseable	UJ232		Brute Force Greaseable	UJ232
	Brute Force Non Greaseable	UJ231		Brute Force Non Greaseable	UJ231
	(For Aluminum Drive Shaft)	UJ331C		(For Aluminum Drive Shaft)	UJ331C
	U-Joint (Rr. Shaft; Rr.) [⊙]	[2] UJ331		U-Joint (Rr. Shaft; Rr.) [⊙]	[2] UJ331
	Brute Force Greaseable	UJ232		Brute Force Greaseable	UJ232
	Brute Force Non Greaseable	UJ231		Brute Force Non Greaseable	UJ231
	(For Aluminum Drive Shaft)	UJ331C		(For Aluminum Drive Shaft)	UJ331C
	U-Joint (Rr. Shaft; Frt.) [⊙]	UJ358A		U-Joint (Rr. Shaft; Frt.) [⊙]	UJ351A
	Brute Force Non Greaseable	UJ358ABF		Brute Force Non Greaseable	UJ351ABF
	U-Joint (Rr. Shaft; Rr.) [⊙]	UJ358A		U-Joint (Rr. Shaft; Ctr.) [⊙]	UJ351A
	Brute Force Non Greaseable	UJ358ABF		Brute Force Non Greaseable	UJ351ABF
	U-Joint (Wheel Joint) [⊙]	[2] UJ479		U-Joint (Rr. Shaft; Rr.) [⊙]	UJ351A
	Centering Ball Kit	UJ617		Brute Force Non Greaseable	UJ351ABF
	H Yoke	UJ650		U-Joint (Wheel Joint) [⊙]	[2] UJ479
2010	R3500 Cab & Chassis w/ 3 Joint Rr. Shaft & Dual Rr. Whls.: [Type 27]		2009-2008	R3500 Pickup w/ Diesel Eng., Frt. Shaft CV w/ Outer Lock Rings & 3 Joint Rr. Shaft: [Type 27]	
	U-Joint (Fr. Shaft; Frt.) [⊙]	UJ331		U-Joint (Fr. Shaft; Frt.) [⊙]	UJ331
	Brute Force Greaseable	UJ232		Brute Force Greaseable	UJ232
	Brute Force Non Greaseable	UJ231		Brute Force Non Greaseable	UJ231
	(For Aluminum Drive Shaft)	UJ331C		(For Aluminum Drive Shaft)	UJ331C
	U-Joint (Fr. Shaft; Rr.) [⊙]	[2] UJ331		U-Joint (Fr. Shaft; Rr.) [⊙]	[2] UJ331
	Brute Force Greaseable	UJ232		Brute Force Greaseable	UJ232
	Brute Force Non Greaseable	UJ231		Brute Force Non Greaseable	UJ231
	(For Aluminum Drive Shaft)	UJ331C		(For Aluminum Drive Shaft)	UJ331C
	U-Joint (Rr. Shaft; Frt.) [⊙]	UJ358A		U-Joint (Rr. Shaft; Frt.) [⊙]	UJ351A
	Brute Force Non Greaseable	UJ358ABF		Brute Force Non Greaseable	UJ351ABF
	U-Joint (Rr. Shaft; Ctr.) [⊙]	UJ358A		U-Joint (Rr. Shaft; Ctr.) [⊙]	UJ351A
	Brute Force Non Greaseable	UJ358ABF		Brute Force Non Greaseable	UJ351ABF
	U-Joint (Rr. Shaft; Rr.) [⊙]	UJ358A		U-Joint (Rr. Shaft; Rr.) [⊙]	UJ351A
	Brute Force Non Greaseable	UJ358ABF		Brute Force Non Greaseable	UJ351ABF
	U-Joint (Wheel Joint) [⊙]	[2] UJ479		U-Joint (Wheel Joint) [⊙]	[2] UJ464
	Centering Ball Kit	UJ617		Centering Ball Kit	UJ617
	H Yoke	UJ650		H Yoke	UJ650

(Continued)

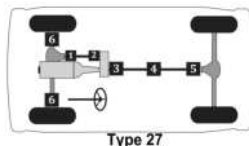
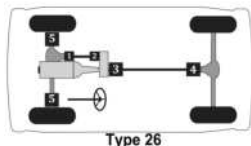

278 ▲ For Use w/ 1.063" Bearing Cap Application. ⊙ For Use w/ 1.188" Bearing Cap Application. ◇ For Use w/ Inner Lock Ring Application on Half Shaft. □ For Use w/ Outer Lock Ring Application on Half Shaft.

Passenger cars, light & medium trucks

(Cont.) -- Dodge Truck 1 ton

MFG./YEAR	MODEL & LOCATION	PART NO.	MFG./YEAR	MODEL & LOCATION	PART NO.
Drive Shaft (4 W/D) (Cont.)			Drive Shaft (4 W/D) (Cont.)		
U-Joint (Cont.)			U-Joint (Cont.)		
2009-2008 R3500 Pickup w/ Diesel Eng., Frt. Shaft CV w/ Inner Lock Rings & 2 Joint Rr. Shaft: [Type 26]			2009-2008 R3500 Pickup w/ Gas Eng., Frt. Shaft CV w/ Outer Lock Rings & 3 Joint Rr. Shaft: [Type 27]		
U-Joint (Frt. Shaft; Frt.)①		UJ534G	U-Joint (Frt. Shaft; Frt.)①		UJ331
Brute Force Greaseable		UJ235	Brute Force Greaseable		UJ232
Brute Force Non Greaseable		UJ234	Brute Force Non Greaseable		UJ231
U-Joint (Frt. Shaft; Rr.)②	[2]	UJ534G	(For Aluminum Drive Shaft)		UJ331C
Brute Force Greaseable		UJ235	U-Joint (Frt. Shaft; Rr.)②	[2]	UJ331
Brute Force Non Greaseable		UJ234	Brute Force Greaseable		UJ232
U-Joint (Rr. Shaft; Frt.)③		UJ351A	Brute Force Non Greaseable		UJ231
Brute Force Non Greaseable		UJ351ABF	(For Aluminum Drive Shaft)		UJ331C
U-Joint (Rr. Shaft; Rr.)④		UJ351A	U-Joint (Rr. Shaft; Frt.)③		UJ330A
Brute Force Non Greaseable		UJ351ABF	Brute Force Greaseable		UJ295A
U-Joint (Wheel Joint)⑤	[2]	UJ464	U-Joint (Rr. Shaft; Ctr.)④		UJ330A
Ball Seat Repair Kit		UJ606	Brute Force Greaseable		UJ295A
H Yoke		UJ646	U-Joint (Rr. Shaft; Rr.)④		UJ330A
2009-2008 R3500 Pickup w/ Diesel Eng., Frt. Shaft CV w/ Inner Lock Rings & 3 Joint Rr. Shaft: [Type 27]			Brute Force Greaseable		UJ295A
U-Joint (Frt. Shaft; Frt.)①		UJ534G	U-Joint (Wheel Joint)⑤	[2]	UJ464
Brute Force Greaseable		UJ235	Centering Ball Kit		UJ617
Brute Force Non Greaseable		UJ234	H Yoke		UJ650
U-Joint (Frt. Shaft; Rr.)②	[2]	UJ534G	2009-2008 R3500 Pickup w/ Gas Eng., Frt. Shaft CV w/ Inner Lock Rings & 2 Joint Rr. Shaft: [Type 26]		
Brute Force Greaseable		UJ235	U-Joint (Frt. Shaft; Frt.)①		UJ534G
Brute Force Non Greaseable		UJ234	Brute Force Greaseable		UJ235
U-Joint (Rr. Shaft; Frt.)③		UJ351A	Brute Force Non Greaseable		UJ234
Brute Force Non Greaseable		UJ351ABF	U-Joint (Frt. Shaft; Rr.)②	[2]	UJ534G
U-Joint (Rr. Shaft; Ctr.)④		UJ351A	Brute Force Greaseable		UJ235
Brute Force Non Greaseable		UJ351ABF	Brute Force Non Greaseable		UJ234
U-Joint (Rr. Shaft; Rr.)⑤		UJ351A	U-Joint (Rr. Shaft; Frt.)③		UJ330A
Brute Force Non Greaseable		UJ351ABF	Brute Force Greaseable		UJ295A
U-Joint (Wheel Joint)⑥	[2]	UJ464	U-Joint (Rr. Shaft; Rr.)④		UJ330A
Ball Seat Repair Kit		UJ606	Brute Force Greaseable		UJ295A
H Yoke		UJ646	U-Joint (Wheel Joint)⑥	[2]	UJ464
2009-2008 R3500 Pickup w/ Diesel Eng., Frt. Shaft CV w/ Outer Lock Rings & 2 Joint Rr. Shaft: [Type 26]			Ball Seat Repair Kit		UJ606
U-Joint (Frt. Shaft; Frt.)①		UJ331	H Yoke		UJ646
Brute Force Greaseable		UJ232			(Continued)
Brute Force Non Greaseable		UJ231			
(For Aluminum Drive Shaft)		UJ331C			
U-Joint (Frt. Shaft; Rr.)②	[2]	UJ331			
Brute Force Greaseable		UJ232			
Brute Force Non Greaseable		UJ231			
(For Aluminum Drive Shaft)		UJ331C			
U-Joint (Rr. Shaft; Frt.)③		UJ351A			
Brute Force Non Greaseable		UJ351ABF			
U-Joint (Rr. Shaft; Rr.)④		UJ351A			
Brute Force Non Greaseable		UJ351ABF			
U-Joint (Wheel Joint)⑤	[2]	UJ464			
Centering Ball Kit		UJ617			
H Yoke		UJ650			

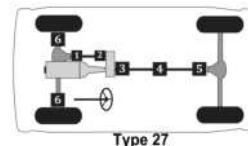
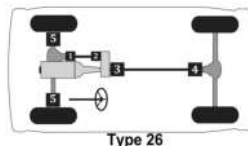

Passenger cars, light & medium trucks

Dodge Truck 1 ton -- (Cont.)

MFG./YEAR	MODEL & LOCATION	PART NO.	MFG./YEAR	MODEL & LOCATION	PART NO.
Drive Shaft (4 W/D) (Cont.)			Drive Shaft (4 W/D) (Cont.)		
U-Joint (Cont.)			U-Joint (Cont.)		
2009-2008 R3500 Pickup w/ Gas Eng., Frt. Shaft CV w/ Inner Lock Rings & 3 Joint Rr. Shaft: [Type 27]			2009-2008 R3500 Cab & Chassis w/ Frt. Shaft Outer Lock Rings & 3 Joint Rr. Shaft: [Type 27]		
U-Joint (Frt. Shaft; Frt.)ⓐ		UJ534G	U-Joint (Frt. Shaft; Frt.)ⓐ		UJ331
Brute Force Greaseable		UJ235	Brute Force Greaseable		UJ232
Brute Force Non Greaseable		UJ234	Brute Force Non Greaseable		UJ231
U-Joint (Frt. Shaft; Rr.)ⓑ	[2]	UJ534G	(For Aluminum Drive Shaft)		UJ331C
Brute Force Greaseable		UJ235	U-Joint (Frt. Shaft; Rr.)ⓑ	[2]	UJ331
Brute Force Non Greaseable		UJ234	Brute Force Greaseable		UJ232
U-Joint (Rr. Shaft; Frt.)ⓐ		UJ330A	Brute Force Non Greaseable		UJ231
Brute Force Greaseable		UJ295A	(For Aluminum Drive Shaft)		UJ331C
U-Joint (Rr. Shaft; Ctr.)ⓐ		UJ330A	U-Joint (Rr. Shaft; Frt.)ⓐ		UJ358A
Brute Force Greaseable		UJ295A	Brute Force Non Greaseable		UJ358ABF
U-Joint (Rr. Shaft; Rr.)ⓑ		UJ330A	U-Joint (Rr. Shaft; Ctr.)ⓐ		UJ358A
Brute Force Greaseable		UJ295A	Brute Force Non Greaseable		UJ358ABF
U-Joint (Wheel Joint)ⓐ	[2]	UJ464	U-Joint (Rr. Shaft; Rr.)ⓑ		UJ358A
Ball Seat Repair Kit		UJ606	Brute Force Non Greaseable		UJ358ABF
H Yoke		UJ646	U-Joint (Wheel Joint)ⓐ	[2]	UJ464
2009-2008 R3500 Pickup w/ Gas Eng., Frt. Shaft CV w/ Outer Lock Rings & 2 Joint Rr. Shaft: [Type 26]			Centering Ball Kit		UJ617
U-Joint (Frt. Shaft; Frt.)ⓐ		UJ331	2009-2008 R3500 Cab & Chassis w/ Frt. Shaft Inner Lock Rings & 2 Joint Rr. Shaft: [Type 26]		
Brute Force Greaseable		UJ232	U-Joint (Frt. Shaft; Frt.)ⓐ		UJ534G
Brute Force Non Greaseable		UJ231	Brute Force Greaseable		UJ235
(For Aluminum Drive Shaft)		UJ331C	Brute Force Non Greaseable		UJ234
U-Joint (Frt. Shaft; Rr.)ⓑ		UJ331	U-Joint (Frt. Shaft; Rr.)ⓑ	[2]	UJ534G
Brute Force Greaseable		UJ232	Brute Force Greaseable		UJ235
Brute Force Non Greaseable		UJ231	Brute Force Non Greaseable		UJ234
(For Aluminum Drive Shaft)		UJ331C	U-Joint (Rr. Shaft; Frt.)ⓐ		UJ358A
U-Joint (Rr. Shaft; Frt.)ⓐ		UJ330A	Brute Force Non Greaseable		UJ358ABF
Brute Force Greaseable		UJ295A	U-Joint (Rr. Shaft; Rr.)ⓑ		UJ358A
U-Joint (Rr. Shaft; Rr.)ⓑ		UJ330A	Brute Force Non Greaseable		UJ358ABF
Brute Force Greaseable		UJ295A	U-Joint (Wheel Joint)ⓐ	[2]	UJ464
U-Joint (Wheel Joint)ⓐ	[2]	UJ464	Ball Seat Repair Kit		UJ606
Centering Ball Kit		UJ617	H Yoke		UJ646
H Yoke		UJ650			(Continued)

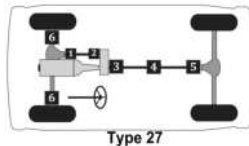
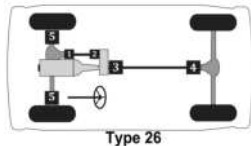

280 ▲ For Use w/ 1.063" Bearing Cap Application. ⓐ For Use w/ 1.188" Bearing Cap Application. ◇ For Use w/ Inner Lock Ring Application on Half Shaft. □ For Use w/ Outer Lock Ring Application on Half Shaft.



MFG./YEAR	MODEL & LOCATION	PART NO.	MFG./YEAR	MODEL & LOCATION	PART NO.
Drive Shaft (4 W/D) (Cont.)			Drive Shaft (4 W/D) (Cont.)		
U-Joint (Cont.)			U-Joint (Cont.)		
2009-2008 R3500 Cab & Chassis w/ Frt. Shaft			2007 R3500 Pickup w/ Gas Eng. & 3 Joint		
Inner Lock Rings & 3 Joint Rr. Shaft:			Rr. Shaft: [Type 27]		
[Type 27]					
U-Joint (Frt. Shaft; Frt.)①		UJ534G	U-Joint (Frt. Shaft; Frt.)①		UJ534G
Brute Force Greaseable		UJ235	Brute Force Greaseable		UJ235
Brute Force Non Greaseable		UJ234	Brute Force Non Greaseable		UJ234
U-Joint (Frt. Shaft; Rr.)②	[2]	UJ534G	U-Joint (Frt. Shaft; Rr.)②	[2]	UJ331A
Brute Force Greaseable		UJ235	Brute Force Greaseable		UJ232A
Brute Force Non Greaseable		UJ234	U-Joint (Rr. Shaft; Frt.)③		UJ330A
U-Joint (Rr. Shaft; Frt.)③		UJ358A	Brute Force Greaseable		UJ295A
Brute Force Non Greaseable		UJ358ABF	U-Joint (Rr. Shaft; Ctr.)④		UJ330A
U-Joint (Rr. Shaft; Ctr.)④		UJ358A	Brute Force Greaseable		UJ295A
Brute Force Non Greaseable		UJ358ABF	U-Joint (Rr. Shaft; Rr.)⑤		UJ330A
U-Joint (Rr. Shaft; Rr.)⑤		UJ358A	Brute Force Greaseable		UJ295A
Brute Force Non Greaseable		UJ358ABF	U-Joint (Wheel Joint)⑥	[2]	UJ464
U-Joint (Wheel Joint)⑥	[2]	UJ464	Centering Ball Kit		UJ617
Ball Seat Repair Kit		UJ606	2007 R3500 Cab & Chassis w/ 2 Joint Rr. Shaft: [Type 26]		
H Yoke		UJ646	U-Joint (Frt. Shaft; Frt.)①		UJ534G
2009-2008 R3500 Cab & Chassis w/ Frt. Shaft			Brute Force Greaseable		UJ235
Outer Lock Rings & 2 Joint Rr. Shaft:			Brute Force Non Greaseable		UJ234
[Type 26]			U-Joint (Frt. Shaft; Rr.)②	[2]	UJ534G
U-Joint (Frt. Shaft; Frt.)①		UJ331	Brute Force Greaseable		UJ235
Brute Force Greaseable		UJ232	Brute Force Non Greaseable		UJ234
Brute Force Non Greaseable		UJ231	U-Joint (Rr. Shaft; Frt.)③		UJ358A
(For Aluminum Drive Shaft)		UJ331C	Brute Force Non Greaseable		UJ358ABF
U-Joint (Frt. Shaft; Rr.)②	[2]	UJ331	U-Joint (Rr. Shaft; Rr.)④		UJ358A
Brute Force Greaseable		UJ232	Brute Force Non Greaseable		UJ358ABF
Brute Force Non Greaseable		UJ231	U-Joint (Wheel Joint)⑥	[2]	UJ464
(For Aluminum Drive Shaft)		UJ331C	2007 R3500 Cab & Chassis w/ 3 Joint Rr. Shaft: [Type 27]		
U-Joint (Rr. Shaft; Frt.)③		UJ358A	U-Joint (Frt. Shaft; Frt.)①		UJ534G
Brute Force Non Greaseable		UJ358ABF	Brute Force Greaseable		UJ235
U-Joint (Rr. Shaft; Rr.)④		UJ358A	Brute Force Non Greaseable		UJ234
Brute Force Non Greaseable		UJ358ABF	U-Joint (Frt. Shaft; Rr.)②	[2]	UJ534G
U-Joint (Wheel Joint)⑥	[2]	UJ464	Brute Force Greaseable		UJ235
Centering Ball Kit		UJ617	Brute Force Non Greaseable		UJ234
2007 R3500 Pickup w/ Gas Eng. & 2 Joint			U-Joint (Rr. Shaft; Frt.)③		UJ358A
Rr. Shaft: [Type 26]			Brute Force Non Greaseable		UJ358ABF
U-Joint (Frt. Shaft; Frt.)①		UJ534G	U-Joint (Rr. Shaft; Ctr.)④		UJ358A
Brute Force Greaseable		UJ235	Brute Force Non Greaseable		UJ358ABF
Brute Force Non Greaseable		UJ234	U-Joint (Rr. Shaft; Rr.)⑤		UJ358A
U-Joint (Frt. Shaft; Rr.)②	[2]	UJ331A	Brute Force Non Greaseable		UJ358ABF
Brute Force Greaseable		UJ232A	U-Joint (Wheel Joint)⑥	[2]	UJ464
U-Joint (Rr. Shaft; Frt.)③		UJ330A	(Continued)		
Brute Force Greaseable		UJ295A			
U-Joint (Rr. Shaft; Rr.)④		UJ330A			
Brute Force Greaseable		UJ295A			
U-Joint (Wheel Joint)⑥	[2]	UJ464			
Centering Ball Kit		UJ617			

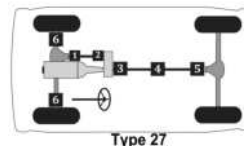
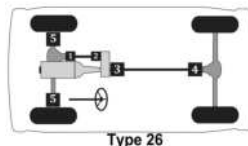

Passenger cars, light & medium trucks

Dodge Truck 1 ton -- (Cont.)

MFG./YEAR	MODEL & LOCATION	PART NO.	MFG./YEAR	MODEL & LOCATION	PART NO.
-----------	------------------	----------	-----------	------------------	----------

Drive Shaft (4 W/D) (Cont.)

U-Joint (Cont.)

2007	R3500 Pickup w/ Diesel Eng., 4 Spd. Auto. Trans. & 3 Joint Rr. Shaft:	
	[Type 27]	
	U-Joint (Fr. Shaft; Frt.) [⊙]	UJ534G
	Brute Force Greaseable	UJ235
	Brute Force Non Greaseable	UJ234
	U-Joint (Fr. Shaft; Rr.) [⊙]	[2] UJ331A
	Brute Force Greaseable	UJ232A
	U-Joint (Rr. Shaft; Frt.) [⊙]	UJ330A
	Brute Force Greaseable	UJ295A
	U-Joint (Rr. Shaft; Ctr.) [⊙]	UJ330A
	Brute Force Greaseable	UJ295A
	U-Joint (Rr. Shaft; Rr.) [⊙]	UJ330A
	Brute Force Greaseable	UJ295A
	U-Joint (Wheel Joint) [⊙]	[2] UJ464
	Centering Ball Kit	UJ617
2007	R3500 Pickup w/ Diesel Eng., 2 Joint Rr. Shaft Exc. 4 Spd. Auto. Trans.:	
	[Type 26]	
	U-Joint (Fr. Shaft; Frt.) [⊙]	UJ534G
	Brute Force Greaseable	UJ235
	Brute Force Non Greaseable	UJ234
	U-Joint (Fr. Shaft; Rr.) [⊙]	[2] UJ331A
	Brute Force Greaseable	UJ232A
	U-Joint (Rr. Shaft; Frt.) [⊙]	UJ351A
	Brute Force Non Greaseable	UJ351ABF
	U-Joint (Rr. Shaft; Rr.) [⊙]	UJ351A
	Brute Force Non Greaseable	UJ351ABF
	U-Joint (Wheel Joint) [⊙]	[2] UJ464
	Centering Ball Kit	UJ617
2007	R3500 Pickup w/ Diesel Eng., 3 Joint Rr. Shaft Exc. 4 Spd. Auto. Trans.:	
	[Type 27]	
	U-Joint (Fr. Shaft; Frt.) [⊙]	UJ534G
	Brute Force Greaseable	UJ235
	Brute Force Non Greaseable	UJ234
	U-Joint (Fr. Shaft; Rr.) [⊙]	[2] UJ331A
	Brute Force Greaseable	UJ232A
	U-Joint (Rr. Shaft; Frt.) [⊙]	UJ351A
	Brute Force Non Greaseable	UJ351ABF
	U-Joint (Rr. Shaft; Ctr.) [⊙]	UJ351A
	Brute Force Non Greaseable	UJ351ABF
	U-Joint (Rr. Shaft; Rr.) [⊙]	UJ351A
	Brute Force Non Greaseable	UJ351ABF
	U-Joint (Wheel Joint) [⊙]	[2] UJ464
	Centering Ball Kit	UJ617

Drive Shaft (4 W/D) (Cont.)

U-Joint (Cont.)

2007	R3500 Pickup w/ Diesel Eng., 4 Spd. Auto. Trans. & 2 Joint Rr. Shaft:	
	[Type 26]	
	U-Joint (Fr. Shaft; Frt.) [⊙]	UJ534G
	Brute Force Greaseable	UJ235
	Brute Force Non Greaseable	UJ234
	U-Joint (Fr. Shaft; Rr.) [⊙]	[2] UJ331A
	Brute Force Greaseable	UJ232A
	U-Joint (Rr. Shaft; Frt.) [⊙]	UJ330A
	Brute Force Greaseable	UJ295A
	U-Joint (Rr. Shaft; Rr.) [⊙]	UJ330A
	Brute Force Greaseable	UJ295A
	U-Joint (Wheel Joint) [⊙]	[2] UJ464
	Centering Ball Kit	UJ617
	2006-2005 R3500 w/ Gas Eng. & 2 Joint Rr. Shaft:	
	[Type 26]	
	U-Joint (Fr. Shaft; Frt.) [⊙]	UJ534G
	Brute Force Greaseable	UJ235
	Brute Force Non Greaseable	UJ234
	U-Joint (Fr. Shaft; Rr.) [⊙]	[2] UJ331A
	Brute Force Greaseable	UJ232A
	U-Joint (Rr. Shaft; Frt.) [⊙]	UJ358A
	Brute Force Non Greaseable	UJ358ABF
	U-Joint (Rr. Shaft; Rr.) [⊙]	UJ358A
	Brute Force Non Greaseable	UJ358ABF
	U-Joint (Wheel Joint) [⊙]	[2] UJ464
	Centering Ball Kit	UJ617
	2006-2005 R3500 w/ Gas Eng. & 3 Joint Rr. Shaft:	
	[Type 27]	
	U-Joint (Fr. Shaft; Frt.) [⊙]	UJ534G
	Brute Force Greaseable	UJ235
	Brute Force Non Greaseable	UJ234
	U-Joint (Fr. Shaft; Rr.) [⊙]	UJ331A
	Brute Force Greaseable	UJ232A
	U-Joint (Rr. Shaft; Frt.) [⊙]	UJ358A
	Brute Force Non Greaseable	UJ358ABF
	U-Joint (Rr. Shaft; Ctr.) [⊙]	UJ358A
	Brute Force Non Greaseable	UJ358ABF
	U-Joint (Rr. Shaft; Rr.) [⊙]	UJ358A
	Brute Force Non Greaseable	UJ358ABF
	U-Joint (Wheel Joint) [⊙]	[2] UJ464
	Centering Ball Kit	UJ617

(Continued)

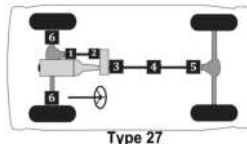
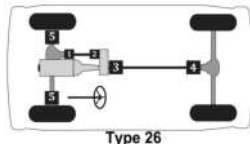

MFG./YEAR	MODEL & LOCATION	PART NO.	MFG./YEAR	MODEL & LOCATION	PART NO.
Drive Shaft (4 W/D) (Cont.)			Drive Shaft (4 W/D) (Cont.)		
U-Joint (Cont.)			U-Joint (Cont.)		
2006-2005 R3500 w/ Diesel Eng., Man. Trans. & 3			2006-2005 R3500 w/ Diesel Eng., Man. Trans. & 2		
Joint Rr. Shaft: [Type 27]			Joint Rr. Shaft: [Type 26]		
U-Joint (Frnt. Shaft; Frnt.)①		UJ534G	U-Joint (Frnt. Shaft; Frnt.)①		UJ534G
Brute Force Greaseable		UJ235	Brute Force Greaseable		UJ235
Brute Force Non Greaseable		UJ234	Brute Force Non Greaseable		UJ234
U-Joint (Frnt. Shaft; Rr.)②	[2]	UJ331A	U-Joint (Frnt. Shaft; Rr.)②	[2]	UJ331A
Brute Force Greaseable		UJ232A	Brute Force Greaseable		UJ232A
U-Joint (Rr. Shaft; Frnt.)③		UJ351A	U-Joint (Rr. Shaft; Frnt.)③		UJ351A
Brute Force Non Greaseable		UJ351ABF	Brute Force Non Greaseable		UJ351ABF
U-Joint (Rr. Shaft; Ctr.)④		UJ351A	U-Joint (Rr. Shaft; Rr.)⑤		UJ351A
Brute Force Non Greaseable		UJ351ABF	Brute Force Non Greaseable		UJ351ABF
U-Joint (Rr. Shaft; Rr.)⑥		UJ351A	U-Joint (Wheel Joint)⑦	[2]	UJ464
Brute Force Non Greaseable		UJ351ABF	Centering Ball Kit		UJ617
U-Joint (Wheel Joint)⑧	[2]	UJ464	2004-2003 R3500 w/ 3 Joint Rr. Shaft. Exc. 6 Spd.		
Centering Ball Kit		UJ617	Man. Trans.: [Type 27]		
2006-2005 R3500 w/ Diesel Eng., Auto. Trans. & 3			U-Joint (Frnt. Shaft; Frnt.)①		
Joint Rr. Shaft: [Type 27]			UJ534G		
U-Joint (Frnt. Shaft; Frnt.)①		UJ534G	Brute Force Greaseable		UJ235
Brute Force Greaseable		UJ235	Brute Force Non Greaseable		UJ234
Brute Force Non Greaseable		UJ234	U-Joint (Frnt. Shaft; Rr.)②	[2]	UJ354
U-Joint (Frnt. Shaft; Rr.)②	[2]	UJ331A	Brute Force Greaseable		UJ270
Brute Force Greaseable		UJ232A	Brute Force Non Greaseable		UJ254
U-Joint (Rr. Shaft; Frnt.)③		UJ330A	(For Aluminum Drive Shaft)		UJ354C
Brute Force Greaseable		UJ295A	U-Joint (Rr. Shaft; Frnt.)③		UJ330A
U-Joint (Rr. Shaft; Ctr.)④		UJ330A	Brute Force Greaseable		UJ295A
Brute Force Greaseable		UJ295A	U-Joint (Rr. Shaft; Ctr.)④		UJ330A
U-Joint (Rr. Shaft; Rr.)⑤		UJ330A	Brute Force Greaseable		UJ295A
Brute Force Greaseable		UJ295A	U-Joint (Rr. Shaft; Rr.)⑤		UJ330A
U-Joint (Wheel Joint)⑧	[2]	UJ464	Brute Force Greaseable		UJ295A
Centering Ball Kit		UJ617	U-Joint (Wheel Joint)⑧	[2]	UJ464
2006-2005 R3500 w/ Diesel Eng., Auto. Trans. & 2			Centering Ball Kit		
Joint Rr. Shaft: [Type 26]			UJ617		
U-Joint (Frnt. Shaft; Frnt.)①		UJ534G	2004-2003 R3500 w/ 6 Spd. Man. Trans. & 2 Joint		
Brute Force Greaseable		UJ235	Rr. Shaft: [Type 26]		
Brute Force Non Greaseable		UJ234	U-Joint (Frnt. Shaft; Frnt.)①		
U-Joint (Frnt. Shaft; Rr.)②	[2]	UJ331A	UJ534G		
Brute Force Greaseable		UJ232A	Brute Force Greaseable		
U-Joint (Rr. Shaft; Frnt.)③		UJ330A	UJ235		
Brute Force Greaseable		UJ295A	Brute Force Non Greaseable		
U-Joint (Rr. Shaft; Rr.)④		UJ330A	UJ234		
Brute Force Greaseable		UJ295A	U-Joint (Frnt. Shaft; Rr.)②		
U-Joint (Wheel Joint)⑧	[2]	UJ464	[2] UJ354		
Centering Ball Kit		UJ617	Brute Force Greaseable		
			UJ270		
			Brute Force Non Greaseable		
			UJ254		
			(For Aluminum Drive Shaft)		
			UJ354C		
			U-Joint (Rr. Shaft; Frnt.)③		
			UJ351A		
			Brute Force Non Greaseable		
			UJ351ABF		
			U-Joint (Rr. Shaft; Rr.)④		
			UJ351A		
			Brute Force Non Greaseable		
			UJ351ABF		
			U-Joint (Wheel Joint)⑧		
			[2] UJ464		
			Centering Ball Kit		
			UJ617		
			Flange Yoke		
			UJ628C		
			H Yoke		
			UJ648		

(Continued)

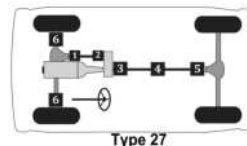
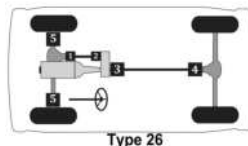

Passenger cars, light & medium trucks

Dodge Truck 1 ton -- (Cont.)

MFG./YEAR	MODEL & LOCATION	PART NO.	MFG./YEAR	MODEL & LOCATION	PART NO.
Drive Shaft (4 W/D) (Cont.)			Drive Shaft (4 W/D) (Cont.)		
U-Joint (Cont.)			U-Joint (Cont.)		
2004-2003 R3500 w/ 6 Spd. Man. Trans. & 3 Joint			2002-2000 R3500 w/ 2 Joint Shaft: [Type 26]		
	Rr. Shaft: [Type 27]		U-Joint (Frnt. Shaft; Frnt.) ⓐ		UJ354
	U-Joint (Frnt. Shaft; Frnt.) ⓐ	UJ534G	<i>Brute Force Greaseable</i>		UJ270
	<i>Brute Force Greaseable</i>	UJ235	<i>Brute Force Non Greaseable</i>		UJ254
	<i>Brute Force Non Greaseable</i>	UJ234	(For Aluminum Drive Shaft)		UJ354C
	U-Joint (Frnt. Shaft; Rr.) ⓐ	UJ354 [2]	Clamp Kit (Frnt. Shaft; Frnt.)		UJ437-10
	<i>Brute Force Greaseable</i>	UJ270	U-Joint (Frnt. Shaft; Rr.) ⓐ	[2]	UJ354
	<i>Brute Force Non Greaseable</i>	UJ254	<i>Brute Force Greaseable</i>		UJ270
	(For Aluminum Drive Shaft)	UJ354C	<i>Brute Force Non Greaseable</i>		UJ254
	U-Joint (Rr. Shaft; Frnt.) ⓐ	UJ351A	(Aluminum Drive Shaft)		UJ354C
	<i>Brute Force Non Greaseable</i>	UJ351ABF	Clamp Kit (Frnt. Shaft; Rr.)		UJ437-10
	U-Joint (Rr. Shaft; Ctr.) ⓐ	UJ351A	U-Joint (Rr. Shaft; Frnt.) ⓐ		UJ330
	<i>Brute Force Non Greaseable</i>	UJ351ABF	<i>Brute Force Greaseable</i>		UJ295
	U-Joint (Rr. Shaft; Rr.) ⓐ	UJ351A	(For Aluminum Drive Shaft)		UJ330C
	<i>Brute Force Non Greaseable</i>	UJ351ABF	U-Joint (Rr. Shaft; Rr.) ⓐ		UJ330
	U-Joint (Wheel Joint) ⓐ	UJ464 [2]	<i>Brute Force Greaseable</i>		UJ295
	Centering Ball Kit	UJ617	(For Aluminum Drive Shaft)		UJ330C
	Flange Yoke	UJ628C	U-Joint (Wheel Joint) ⓐ	[2]	UJ374
	H Yoke	UJ648	<i>Brute Force Non Greaseable</i>		UJ374BF
	2004-2003 R3500 w/ 2 Joint Rr. Shaft. Exc. 6 Spd.		Centering Ball Kit		UJ617
	Man. Trans.: [Type 26]		Flange Yoke		UJ628C
	U-Joint (Frnt. Shaft; Frnt.) ⓐ	UJ534G	H Yoke		UJ648
	<i>Brute Force Greaseable</i>	UJ235	2002-2000 R3500 w/ 3 Joint Shaft: [Type 27]		
	<i>Brute Force Non Greaseable</i>	UJ234	U-Joint (Frnt. Shaft; Frnt.) ⓐ		UJ354
	U-Joint (Frnt. Shaft; Rr.) ⓐ	UJ354 [2]	<i>Brute Force Greaseable</i>		UJ270
	<i>Brute Force Greaseable</i>	UJ270	<i>Brute Force Non Greaseable</i>		UJ254
	<i>Brute Force Non Greaseable</i>	UJ254	(For Aluminum Drive Shaft)		UJ354C
	(For Aluminum Drive Shaft)	UJ354C	Clamp Kit (Frnt. Shaft; Frnt.)		UJ437-10
	U-Joint (Rr. Shaft; Frnt.) ⓐ	UJ330A	U-Joint (Frnt. Shaft; Rr.) ⓐ	[2]	UJ354
	<i>Brute Force Greaseable</i>	UJ295A	<i>Brute Force Greaseable</i>		UJ270
	U-Joint (Rr. Shaft; Rr.) ⓐ	UJ330A	<i>Brute Force Non Greaseable</i>		UJ254
	<i>Brute Force Greaseable</i>	UJ295A	(For Aluminum Drive Shaft)		UJ354C
	U-Joint (Wheel Joint) ⓐ	UJ464 [2]	Clamp Kit (Frnt. Shaft; Rr.)		UJ437-10
	Centering Ball Kit	UJ617	U-Joint (Rr. Shaft; Frnt.) ⓐ		UJ330
	Flange Yoke	UJ628C	<i>Brute Force Greaseable</i>		UJ295
	H Yoke	UJ648	(For Aluminum Drive Shaft)		UJ330C
			U-Joint (Rr. Shaft; Ctr.) ⓐ		UJ330
			<i>Brute Force Greaseable</i>		UJ295
			(For Aluminum Drive Shaft)		UJ330C
			U-Joint (Rr. Shaft; Rr.) ⓐ		UJ330
			<i>Brute Force Greaseable</i>		UJ295
			(For Aluminum Drive Shaft)		UJ330C
			U-Joint (Wheel Joint) ⓐ	[2]	UJ374
			<i>Brute Force Non Greaseable</i>		UJ374BF
			Centering Ball Kit		UJ617
			Flange Yoke		UJ628C
			H Yoke		UJ648

(Continued)

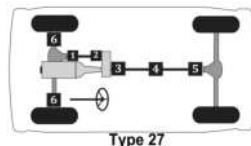
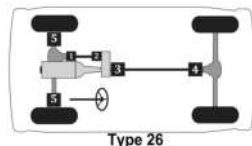

MFG./YEAR	MODEL & LOCATION	PART NO.	MFG./YEAR	MODEL & LOCATION	PART NO.
Drive Shaft (4 W/D) (Cont.)			Drive Shaft (4 W/D) (Cont.)		
U-Joint (Cont.)			U-Joint (Cont.)		
1999-1997 R3500 w/ Frt. Shaft Inner Lock Rings & 2 Joint Rr. Shaft: [Type 26]			1999-1997 R3500 w/ Frt. Shaft Outer Lock Rings & 3 Joint Rr. Shaft: [Type 27]		
U-Joint (Frt. Shaft; Frt.)①		UJ316	U-Joint (Frt. Shaft; Frt.)①		UJ458
Brute Force Greaseable		UJ248	(For Aluminum Drive Shaft)		UJ458C
Clamp Kit (Frt. Shaft; Frt.)		UJ316-10	Brute Force Non Greaseable		UJ458BF
U-Joint (Frt. Shaft; Rr.)②	[2]	UJ354	U-Joint (Frt. Shaft; Rr.)②	[2]	UJ354
Brute Force Greaseable		UJ270	Brute Force Greaseable		UJ270
Brute Force Non Greaseable		UJ254	Brute Force Non Greaseable		UJ254
(For Aluminum Drive Shaft)		UJ354C	(For Aluminum Drive Shaft)		UJ354C
U-Joint (Rr. Shaft; Frt.)③		UJ330	U-Joint (Rr. Shaft; Frt.)③		UJ330
Brute Force Greaseable		UJ295	Brute Force Greaseable		UJ295
(For Aluminum Drive Shaft)		UJ330C	(For Aluminum Drive Shaft)		UJ330C
U-Joint (Rr. Shaft; Rr.)④		UJ330	U-Joint (Rr. Shaft; Ctr.)④		UJ330
Brute Force Greaseable		UJ295	Brute Force Greaseable		UJ295
(For Aluminum Drive Shaft)		UJ330C	(For Aluminum Drive Shaft)		UJ330C
U-Joint (Wheel Joint)⑤	[2]	UJ374	U-Joint (Rr. Shaft; Rr.)⑤		UJ330
Brute Force Non Greaseable		UJ374BF	Brute Force Greaseable		UJ295
Centering Ball Kit		UJ617	(For Aluminum Drive Shaft)		UJ330C
Flange Yoke		UJ628C	U-Joint (Wheel Joint)⑥	[2]	UJ374
H Yoke		UJ648	Brute Force Non Greaseable		UJ374BF
1999-1997 R3500 w/ Frt. Shaft Inner Lock Rings & 3 Joint Rr. Shaft: [Type 27]			1999-1997 R3500 w/ Frt. Shaft Outer Lock Rings & 2 Joint Rr. Shaft: [Type 26]		
U-Joint (Frt. Shaft; Frt.)①		UJ316	U-Joint (Frt. Shaft; Frt.)①		UJ458
Brute Force Greaseable		UJ248	(For Aluminum Drive Shaft)		UJ458C
Clamp Kit (Frt. Shaft; Frt.)		UJ316-10	Brute Force Non Greaseable		UJ458BF
U-Joint (Frt. Shaft; Rr.)②	[2]	UJ354	U-Joint (Frt. Shaft; Rr.)②	[2]	UJ354
Brute Force Greaseable		UJ270	Brute Force Greaseable		UJ270
Brute Force Non Greaseable		UJ254	Brute Force Non Greaseable		UJ254
(For Aluminum Drive Shaft)		UJ354C	(For Aluminum Drive Shaft)		UJ354C
U-Joint (Rr. Shaft; Frt.)③		UJ330	U-Joint (Rr. Shaft; Frt.)③		UJ330
Brute Force Greaseable		UJ295	Brute Force Greaseable		UJ295
(For Aluminum Drive Shaft)		UJ330C	(For Aluminum Drive Shaft)		UJ330C
U-Joint (Rr. Shaft; Ctr.)④		UJ330	U-Joint (Rr. Shaft; Rr.)④		UJ330
Brute Force Greaseable		UJ295	Brute Force Greaseable		UJ295
(For Aluminum Drive Shaft)		UJ330C	(For Aluminum Drive Shaft)		UJ330C
U-Joint (Rr. Shaft; Rr.)⑤		UJ330	U-Joint (Rr. Shaft; Rr.)⑤		UJ330
Brute Force Greaseable		UJ295	Brute Force Greaseable		UJ295
(For Aluminum Drive Shaft)		UJ330C	(For Aluminum Drive Shaft)		UJ330C
U-Joint (Wheel Joint)⑥	[2]	UJ374	U-Joint (Wheel Joint)⑥	[2]	UJ374
Brute Force Non Greaseable		UJ374BF	Brute Force Non Greaseable		UJ374BF
Centering Ball Kit		UJ617	Centering Ball Kit		UJ617
Flange Yoke		UJ628C	Flange Yoke		UJ628C
H Yoke		UJ648	H Yoke		UJ648

(Continued)

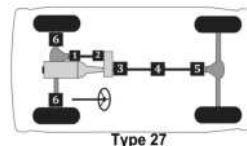
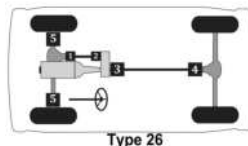

Passenger cars, light & medium trucks

Dodge Truck 1 ton -- (Cont.)

MFG./YEAR	MODEL & LOCATION	PART NO.	MFG./YEAR	MODEL & LOCATION	PART NO.
Drive Shaft (4 W/D) (Cont.)			Drive Shaft (4 W/D) (Cont.)		
U-Joint (Cont.)			U-Joint (Cont.)		
1996-1994 R3500 w/ 2 Joint Shaft: [Type 26]			1993-1992 W350 w/ Diesel Eng., 2.625" Frt. Axle		
			Yoke, 3 Joint Rr. Shaft & 1.375" Dia.		
			Whl. Joint Brg. Caps: [Type 27]		
	U-Joint (Frt. Shaft; Frt.) ①	UJ316		U-Joint (Frt. Shaft; Frt.) ①	UJ316
	<i>Brute Force Greaseable</i>	UJ248		<i>Brute Force Greaseable</i>	UJ248
	Clamp Kit (Frt. Shaft; Frt.)	UJ316-10		Clamp Kit (Frt. Shaft; Frt.)	UJ316-10
	U-Joint (Frt. Shaft; Rr.) ②	[2] UJ354		U-Joint (Frt. Shaft; Rr.) ②	[2] UJ534G
	<i>Brute Force Greaseable</i>	UJ270		<i>Brute Force Greaseable</i>	UJ235
	<i>Brute Force Non Greaseable</i>	UJ254		<i>Brute Force Non Greaseable</i>	UJ234
	(For Aluminum Drive Shaft)	UJ354C		U-Joint (Rr. Shaft; Frt.) ③	UJ330
	U-Joint (Rr. Shaft; Frt.) ③	UJ330		<i>Brute Force Greaseable</i>	UJ295
	<i>Brute Force Greaseable</i>	UJ295		(For Aluminum Drive Shaft)	UJ330C
	(For Aluminum Drive Shaft)	UJ330C		U-Joint (Rr. Shaft; Rr.) ④	UJ330
	U-Joint (Rr. Shaft; Rr.) ④	UJ330		<i>Brute Force Greaseable</i>	UJ295
	<i>Brute Force Greaseable</i>	UJ295		(For Aluminum Drive Shaft)	UJ330C
	(For Aluminum Drive Shaft)	UJ330C		U-Joint (Rr. Shaft; Ctr.) ⑤	UJ330
	U-Joint (Wheel Joint) ⑤	[2] UJ374		<i>Brute Force Greaseable</i>	UJ295
	<i>Brute Force Non Greaseable</i>	UJ374BF		(For Aluminum Drive Shaft)	UJ330C
	Centering Ball Kit	UJ617		U-Joint (Rr. Shaft; Rr.) ⑥	UJ330
	Flange Yoke	UJ628C		<i>Brute Force Greaseable</i>	UJ295
	H Yoke	UJ648		(For Aluminum Drive Shaft)	UJ330C
	1996-1994 R3500 w/ 3 Joint Shaft: [Type 27]			U-Joint (Wheel Joint) ⑥	[2] UJ374
	U-Joint (Frt. Shaft; Frt.) ①	UJ316		<i>Brute Force Non Greaseable</i>	UJ374BF
	<i>Brute Force Greaseable</i>	UJ248		Ball Seat Repair Kit	UJ606
	Clamp Kit (Frt. Shaft; Frt.)	UJ316-10		Flange Yoke	UJ626
	U-Joint (Frt. Shaft; Rr.) ②	[2] UJ354		H Yoke	UJ646
	<i>Brute Force Greaseable</i>	UJ270		1993-1992 W350 w/ Diesel Eng., 2.125" Frt. Axle	
	<i>Brute Force Non Greaseable</i>	UJ254		Yoke, 2 Joint Rr. Shaft & 1.188" Dia.	
	(For Aluminum Drive Shaft)	UJ354C		Whl. Joint Brg. Caps: [Type 26]	
	U-Joint (Rr. Shaft; Frt.) ③	UJ330		U-Joint (Frt. Shaft; Frt.) ①	UJ317
	<i>Brute Force Greaseable</i>	UJ295		<i>Brute Force Greaseable</i>	UJ246
	(For Aluminum Drive Shaft)	UJ330C		Clamp Kit (Frt. Shaft; Frt.)	UJ318-10
	U-Joint (Rr. Shaft; Ctr.) ④	UJ330		U-Joint (Frt. Shaft; Rr.) ②	[2] UJ534G
	<i>Brute Force Greaseable</i>	UJ295		<i>Brute Force Greaseable</i>	UJ235
	(For Aluminum Drive Shaft)	UJ330C		<i>Brute Force Non Greaseable</i>	UJ234
	U-Joint (Rr. Shaft; Rr.) ⑤	UJ330		U-Joint (Rr. Shaft; Frt.) ③	UJ330
	<i>Brute Force Greaseable</i>	UJ295		<i>Brute Force Greaseable</i>	UJ295
	(For Aluminum Drive Shaft)	UJ330C		(For Aluminum Drive Shaft)	UJ330C
	U-Joint (Rr. Shaft; Rr.) ⑥	UJ330		U-Joint (Rr. Shaft; Rr.) ④	UJ330
	<i>Brute Force Greaseable</i>	UJ295		<i>Brute Force Greaseable</i>	UJ295
	(For Aluminum Drive Shaft)	UJ330C		(For Aluminum Drive Shaft)	UJ330C
	U-Joint (Wheel Joint) ⑥	[2] UJ374		U-Joint (Wheel Joint) ⑥	[2] UJ371
	<i>Brute Force Non Greaseable</i>	UJ374BF		<i>Brute Force Greaseable</i>	UJ377
	Centering Ball Kit	UJ617		<i>Brute Force Non Greaseable</i>	UJ371
	Flange Yoke	UJ628C		Ball Seat Repair Kit	UJ606
	H Yoke	UJ648		Flange Yoke	UJ626
				H Yoke	UJ646

(Continued)

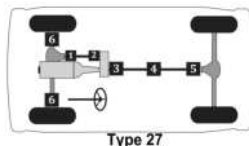
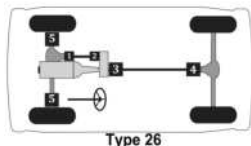

MFG./YEAR	MODEL & LOCATION	PART NO.	MFG./YEAR	MODEL & LOCATION	PART NO.
Drive Shaft (4 W/D) (Cont.)			Drive Shaft (4 W/D) (Cont.)		
U-Joint (Cont.)			U-Joint (Cont.)		
1993-1992 W350 w/ Diesel Eng., 2.125" Frt. Axle			1993-1992 W350 w/ Diesel Eng., 2.125" Frt. Axle		
Yoke, 2 Joint Rr. Shaft & 1.375" Dia.			Yoke, 3 Joint Rr. Shaft & 1.375" Dia.		
Whl. Joint Brg. Caps: [Type 26]			Whl. Joint Brg. Caps: [Type 27]		
U-Joint (Frt. Shaft; Frt.)①		UJ317	U-Joint (Frt. Shaft; Frt.)①		UJ317
Brute Force Greaseable		UJ246	Brute Force Greaseable		UJ246
Clamp Kit (Frt. Shaft; Frt.)		UJ318-10	Clamp Kit (Frt. Shaft; Frt.)		UJ318-10
U-Joint (Frt. Shaft; Rr.)②	[2]	UJ534G	U-Joint (Frt. Shaft; Rr.)②	[2]	UJ534G
Brute Force Greaseable		UJ235	Brute Force Greaseable		UJ235
Brute Force Non Greaseable		UJ234	Brute Force Non Greaseable		UJ234
U-Joint (Rr. Shaft; Frt.)③		UJ330	U-Joint (Rr. Shaft; Frt.)③		UJ330
Brute Force Greaseable		UJ295	Brute Force Greaseable		UJ295
(For Aluminum Drive Shaft)		UJ330C	(For Aluminum Drive Shaft)		UJ330C
U-Joint (Rr. Shaft; Rr.)④		UJ330	U-Joint (Rr. Shaft; Ctr.)④		UJ330
Brute Force Greaseable		UJ295	Brute Force Greaseable		UJ295
(For Aluminum Drive Shaft)		UJ330C	(For Aluminum Drive Shaft)		UJ330C
U-Joint (Wheel Joint)⑤	[2]	UJ374	U-Joint (Rr. Shaft; Rr.)⑤		UJ330
Brute Force Non Greaseable		UJ374BF	Brute Force Greaseable		UJ295
Ball Seat Repair Kit		UJ606	(For Aluminum Drive Shaft)		UJ330C
Flange Yoke		UJ626	U-Joint (Wheel Joint)⑥	[2]	UJ374
H Yoke		UJ646	Brute Force Non Greaseable		UJ374BF
1993-1992 W350 w/ Diesel Eng., 2.125" Frt. Axle			1993-1992 W350 w/ Diesel Eng., 2.625" Frt. Axle		
Yoke, 3 Joint Rr. Shaft & 1.188" Dia.			Yoke, 2 Joint Rr. Shaft & 1.188" Dia.		
Whl. Joint Brg. Caps: [Type 27]			Whl. Joint Brg. Caps: [Type 26]		
U-Joint (Frt. Shaft; Frt.)①		UJ317	U-Joint (Frt. Shaft; Frt.)①		UJ316
Brute Force Greaseable		UJ246	Brute Force Greaseable		UJ248
Clamp Kit (Frt. Shaft; Frt.)		UJ318-10	Clamp Kit (Frt. Shaft; Frt.)		UJ316-10
U-Joint (Frt. Shaft; Rr.)②	[2]	UJ534G	U-Joint (Frt. Shaft; Rr.)②	[2]	UJ534G
Brute Force Greaseable		UJ235	Brute Force Greaseable		UJ235
Brute Force Non Greaseable		UJ234	Brute Force Non Greaseable		UJ234
U-Joint (Rr. Shaft; Frt.)③		UJ330	U-Joint (Rr. Shaft; Frt.)③		UJ330
Brute Force Greaseable		UJ295	Brute Force Greaseable		UJ295
(For Aluminum Drive Shaft)		UJ330C	(For Aluminum Drive Shaft)		UJ330C
U-Joint (Rr. Shaft; Ctr.)④		UJ330	U-Joint (Rr. Shaft; Rr.)④		UJ330
Brute Force Greaseable		UJ295	Brute Force Greaseable		UJ295
(For Aluminum Drive Shaft)		UJ330C	(For Aluminum Drive Shaft)		UJ330C
U-Joint (Rr. Shaft; Rr.)⑤		UJ330	U-Joint (Rr. Shaft; Rr.)⑤		UJ330
Brute Force Greaseable		UJ295	Brute Force Greaseable		UJ295
(For Aluminum Drive Shaft)		UJ330C	(For Aluminum Drive Shaft)		UJ330C
U-Joint (Wheel Joint)⑥	[2]	UJ371	U-Joint (Wheel Joint)⑥	[2]	UJ371
Brute Force Greaseable		UJ377	Brute Force Greaseable		UJ377
Brute Force Non Greaseable		UJ371	Brute Force Non Greaseable		UJ371
Ball Seat Repair Kit		UJ606	Ball Seat Repair Kit		UJ606
Flange Yoke		UJ626	Flange Yoke		UJ626
H Yoke		UJ646	H Yoke		UJ646

(Continued)

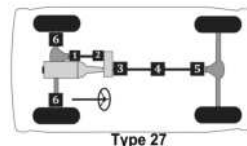
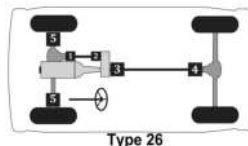

Passenger cars, light & medium trucks

Dodge Truck 1 ton -- (Cont.)

MFG./YEAR	MODEL & LOCATION	PART NO.	MFG./YEAR	MODEL & LOCATION	PART NO.
-----------	------------------	----------	-----------	------------------	----------

Drive Shaft (4 W/D) (Cont.)

U-Joint (Cont.)

1993-1992 W350 w/ Diesel Eng., 2.625" Frt. Axle
 Yoke, 2 Joint Rr. Shaft & 1.375" Dia.
 Whl. Joint Brg. Caps: [Type 26]

U-Joint (Frt. Shaft; Frt.)⊙	UJ316
Brute Force Greaseable	UJ248
Clamp Kit (Frt. Shaft; Frt.)	UJ316-10
U-Joint (Frt. Shaft; Rr.)⊙	[2] UJ534G
Brute Force Greaseable	UJ235
Brute Force Non Greaseable	UJ234
U-Joint (Rr. Shaft; Frt.)⊙	UJ330
Brute Force Greaseable	UJ295
(For Aluminum Drive Shaft)	UJ330C
U-Joint (Rr. Shaft; Rr.)⊙	UJ330
Brute Force Greaseable	UJ295
(For Aluminum Drive Shaft)	UJ330C
U-Joint (Wheel Joint)⊙	[2] UJ374
Brute Force Non Greaseable	UJ374BF
Ball Seat Repair Kit	UJ606
Flange Yoke	UJ626
H Yoke	UJ646

1993-1992 W350 w/ Diesel Eng., 2.625" Frt. Axle
 Yoke, 3 Joint Rr. Shaft & 1.188" Dia.
 Whl. Joint Brg. Caps: [Type 27]

U-Joint (Frt. Shaft; Frt.)⊙	UJ316
Brute Force Greaseable	UJ248
Clamp Kit (Frt. Shaft; Frt.)	UJ316-10
U-Joint (Frt. Shaft; Rr.)⊙	[2] UJ534G
Brute Force Greaseable	UJ235
Brute Force Non Greaseable	UJ234
U-Joint (Rr. Shaft; Frt.)⊙	UJ330
Brute Force Greaseable	UJ295
(For Aluminum Drive Shaft)	UJ330C
U-Joint (Rr. Shaft; Ctr.)⊙	UJ330
Brute Force Greaseable	UJ295
(For Aluminum Drive Shaft)	UJ330C
U-Joint (Rr. Shaft; Rr.)⊙	UJ330
Brute Force Greaseable	UJ295
(For Aluminum Drive Shaft)	UJ330C
U-Joint (Wheel Joint)⊙	[2] UJ371
Brute Force Greaseable	UJ377
Brute Force Non Greaseable	UJ371
Ball Seat Repair Kit	UJ606
Flange Yoke	UJ626
H Yoke	UJ646

Drive Shaft (4 W/D) (Cont.)

U-Joint (Cont.)

1993-1992 W350 w/ Gas Eng., 2.625" Frt. Axle
 Yoke, 3 Joint Rr. Shaft & 1.375" Dia.
 Whl. Joint Brg. Caps: [Type 27]

U-Joint (Frt. Shaft; Frt.)⊙	UJ316
Brute Force Greaseable	UJ248
Clamp Kit (Frt. Shaft; Frt.)	UJ316-10
U-Joint (Frt. Shaft; Rr.)⊙	[2] UJ534G
Brute Force Greaseable	UJ235
Brute Force Non Greaseable	UJ234
U-Joint (Rr. Shaft; Frt.)⊙	UJ330
Brute Force Greaseable	UJ295
(For Aluminum Drive Shaft)	UJ330C
U-Joint (Rr. Shaft; Ctr.)⊙	UJ330
Brute Force Greaseable	UJ295
(For Aluminum Drive Shaft)	UJ330C
U-Joint (Rr. Shaft; Rr.)⊙	UJ330
Brute Force Greaseable	UJ295
(For Aluminum Drive Shaft)	UJ330C
U-Joint (Wheel Joint)⊙	[2] UJ374
Brute Force Non Greaseable	UJ374BF
Ball Seat Repair Kit	UJ606
Flange Yoke	UJ626
H Yoke	UJ646

1993-1992 W350 w/ Gas Eng., 2.125" Frt. Axle
 Yoke, 2 Joint Rr. Shaft & 1.188" Dia.
 Whl. Joint Brg. Caps: [Type 26]

U-Joint (Frt. Shaft; Frt.)⊙	UJ317
Brute Force Greaseable	UJ246
Clamp Kit (Frt. Shaft; Frt.)	UJ318-10
U-Joint (Frt. Shaft; Rr.)⊙	[2] UJ534G
Brute Force Greaseable	UJ235
Brute Force Non Greaseable	UJ234
U-Joint (Rr. Shaft; Frt.)⊙	UJ316
Brute Force Greaseable	UJ248
Clamp Kit (Rr. Shaft; Frt.)	UJ316-10
U-Joint (Rr. Shaft; Rr.)⊙	UJ316
Brute Force Greaseable	UJ248
Clamp Kit (Rr. Shaft; Rr.)	UJ316-10
U-Joint (Wheel Joint)⊙	[2] UJ371
Brute Force Greaseable	UJ377
Brute Force Non Greaseable	UJ371
Ball Seat Repair Kit	UJ606
Flange Yoke	UJ626
H Yoke	UJ646

(Continued)

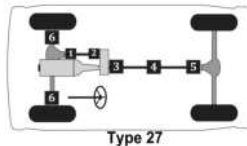
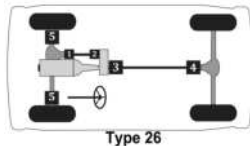

MFG./YEAR	MODEL & LOCATION	PART NO.	MFG./YEAR	MODEL & LOCATION	PART NO.
Drive Shaft (4 W/D) (Cont.)			Drive Shaft (4 W/D) (Cont.)		
U-Joint (Cont.)			U-Joint (Cont.)		
1993-1992 W350 w/ Gas Eng., 2.125" Frt. Axle			1993-1992 W350 w/ Gas Eng., 2.125" Frt. Axle		
Yoke, 2 Joint Rr. Shaft & 1.375" Dia.			Yoke, 3 Joint Rr. Shaft & 1.375" Dia.		
Whl. Joint Brg. Caps: [Type 26]			Whl. Joint Brg. Caps: [Type 27]		
U-Joint (Frt. Shaft; Frt.)①		UJ317	U-Joint (Frt. Shaft; Frt.)①		UJ317
Brute Force Greaseable		UJ246	Brute Force Greaseable		UJ246
Clamp Kit (Frt. Shaft; Frt.)		UJ318-10	Clamp Kit (Frt. Shaft; Frt.)		UJ318-10
U-Joint (Frt. Shaft; Rr.)②	[2]	UJ534G	U-Joint (Frt. Shaft; Rr.)②	[2]	UJ534G
Brute Force Greaseable		UJ235	Brute Force Greaseable		UJ235
Brute Force Non Greaseable		UJ234	Brute Force Non Greaseable		UJ234
U-Joint (Rr. Shaft; Frt.)③		UJ316	U-Joint (Rr. Shaft; Frt.)③		UJ330
Brute Force Greaseable		UJ248	Brute Force Greaseable		UJ295
U-Joint (Rr. Shaft; Rr.)④		UJ316	(For Aluminum Drive Shaft)		UJ330C
Brute Force Greaseable		UJ248	U-Joint (Rr. Shaft; Ctr.)⑤		UJ330
U-Joint (Wheel Joint)⑥	[2]	UJ374	Brute Force Greaseable		UJ295
Brute Force Non Greaseable		UJ374BF	(For Aluminum Drive Shaft)		UJ330C
Ball Seat Repair Kit		UJ606	U-Joint (Rr. Shaft; Rr.)⑥		UJ330
Flange Yoke		UJ626	Brute Force Greaseable		UJ295
H Yoke		UJ646	(For Aluminum Drive Shaft)		UJ330C
1993-1992 W350 w/ Gas Eng., 2.125" Frt. Axle			1993-1992 W350 w/ Gas Eng., 2.625" Frt. Axle		
Yoke, 3 Joint Rr. Shaft & 1.188" Dia.			Yoke, 2 Joint Rr. Shaft & 1.188" Dia.		
Whl. Joint Brg. Caps: [Type 27]			Whl. Joint Brg. Caps: [Type 26]		
U-Joint (Frt. Shaft; Frt.)①		UJ317	U-Joint (Frt. Shaft; Frt.)①		UJ316
Brute Force Greaseable		UJ246	Brute Force Greaseable		UJ248
Clamp Kit (Frt. Shaft; Frt.)		UJ318-10	Clamp Kit (Frt. Shaft; Frt.)		UJ316-10
U-Joint (Frt. Shaft; Rr.)②	[2]	UJ534G	U-Joint (Frt. Shaft; Rr.)②	[2]	UJ534G
Brute Force Greaseable		UJ235	Brute Force Greaseable		UJ235
Brute Force Non Greaseable		UJ234	Brute Force Non Greaseable		UJ234
U-Joint (Rr. Shaft; Frt.)③		UJ330	U-Joint (Rr. Shaft; Frt.)③		UJ316
Brute Force Greaseable		UJ295	Brute Force Greaseable		UJ248
(For Aluminum Drive Shaft)		UJ330C	Clamp Kit (Rr. Shaft; Frt.)		UJ316-10
U-Joint (Rr. Shaft; Ctr.)④		UJ330	U-Joint (Rr. Shaft; Rr.)④		UJ316
Brute Force Greaseable		UJ295	Brute Force Greaseable		UJ248
(For Aluminum Drive Shaft)		UJ330C	Clamp Kit (Rr. Shaft; Rr.)		UJ316-10
U-Joint (Rr. Shaft; Rr.)⑤		UJ330	U-Joint (Wheel Joint)⑥	[2]	UJ371
Brute Force Greaseable		UJ295	Brute Force Greaseable		UJ377
(For Aluminum Drive Shaft)		UJ330C	Brute Force Non Greaseable		UJ371
U-Joint (Wheel Joint)⑥	[2]	UJ371	Ball Seat Repair Kit		UJ606
Brute Force Greaseable		UJ377	Flange Yoke		UJ626
Brute Force Non Greaseable		UJ371	H Yoke		UJ646
Ball Seat Repair Kit		UJ606			
Flange Yoke		UJ626			
H Yoke		UJ646			

(Continued)

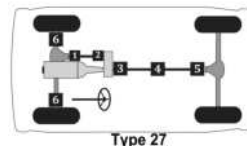
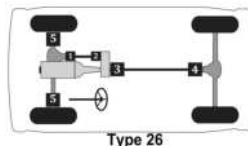

Passenger cars, light & medium trucks

Dodge Truck 1 ton -- (Cont.)

MFG./YEAR	MODEL & LOCATION	PART NO.	MFG./YEAR	MODEL & LOCATION	PART NO.
Drive Shaft (4 W/D) (Cont.)			Drive Shaft (4 W/D) (Cont.)		
U-Joint (Cont.)			U-Joint (Cont.)		
1993-1992 W350 w/ Gas Eng., 2.625" Frt. Axle			1991-1990 W350 w/ Rr. Shaft Outer Lock Rings &		
Yoke, 2 Joint Rr. Shaft & 1.375" Dia.			1.375" Dia. Whl. Joint Brg. Caps:		
Whl. Joint Brg. Caps: [Type 26]			[Type 26]		
U-Joint (Frt. Shaft; Frt.)Ⓚ		UJ316	U-Joint (Frt. Shaft; Frt.)Ⓚ		UJ317
Brute Force Greaseable		UJ248	Brute Force Greaseable		UJ246
Clamp Kit (Frt. Shaft; Frt.)		UJ316-10	Clamp Kit (Frt. Shaft; Frt.)		UJ318-10
U-Joint (Frt. Shaft; Rr.)Ⓚ	[2]	UJ534G	U-Joint (Frt. Shaft; Rr.)Ⓚ	[2]	UJ534G
Brute Force Greaseable		UJ235	Brute Force Greaseable		UJ235
Brute Force Non Greaseable		UJ234	Brute Force Non Greaseable		UJ234
U-Joint (Rr. Shaft; Frt.)Ⓚ		UJ316	U-Joint (Rr. Shaft; Frt.)Ⓚ		UJ330
Brute Force Greaseable		UJ248	Brute Force Greaseable		UJ295
Clamp Kit (Rr. Shaft; Frt.)		UJ316-10	(For Aluminum Drive Shaft)		UJ330C
U-Joint (Rr. Shaft; Rr.)Ⓚ		UJ316	Clamp Kit		UJ331-10
Brute Force Greaseable		UJ248	U-Joint (Rr. Shaft; Rr.)Ⓚ		UJ330
Clamp Kit (Rr. Shaft; Rr.)		UJ316-10	Brute Force Greaseable		UJ295
U-Joint (Wheel Joint)Ⓚ	[2]	UJ374	(For Aluminum Drive Shaft)		UJ330C
Brute Force Non Greaseable		UJ374BF	Clamp Kit		UJ331-10
Ball Seat Repair Kit		UJ606	U-Joint (Wheel Joint)Ⓚ	[2]	UJ374
Flange Yoke		UJ626	Brute Force Non Greaseable		UJ374BF
H Yoke		UJ646	Ball Seat Repair Kit		UJ606
1993-1992 W350 w/ Gas Eng., 2.625" Frt. Axle			Flange Yoke		UJ626
Yoke, 3 Joint Rr. Shaft & 1.188" Dia.			H Yoke		UJ646
Whl. Joint Brg. Caps: [Type 27]			1991-1990 W350 w/ Rr. Shaft Inner Lock Rings &		
U-Joint (Frt. Shaft; Frt.)Ⓚ		UJ316	1.188" Dia. Whl. Joint Brg. Caps:		
Brute Force Greaseable		UJ248	[Type 26]		
Clamp Kit (Frt. Shaft; Frt.)		UJ316-10	U-Joint (Frt. Shaft; Frt.)Ⓚ		UJ317
U-Joint (Frt. Shaft; Rr.)Ⓚ	[2]	UJ534G	Brute Force Greaseable		UJ246
Brute Force Greaseable		UJ235	Clamp Kit (Frt. Shaft; Frt.)		UJ318-10
Brute Force Non Greaseable		UJ234	U-Joint (Frt. Shaft; Rr.)Ⓚ	[2]	UJ534G
U-Joint (Rr. Shaft; Frt.)Ⓚ		UJ330	Brute Force Greaseable		UJ235
Brute Force Greaseable		UJ295	Brute Force Non Greaseable		UJ234
(For Aluminum Drive Shaft)		UJ330C	U-Joint (Rr. Shaft; Frt.)Ⓚ		UJ317
U-Joint (Rr. Shaft; Ctr.)Ⓚ		UJ330	Brute Force Greaseable		UJ246
Brute Force Greaseable		UJ295	Clamp Kit (Rr. Shaft; Frt.)		UJ318-10
(For Aluminum Drive Shaft)		UJ330C	U-Joint (Rr. Shaft; Rr.)Ⓚ		UJ317
U-Joint (Rr. Shaft; Rr.)Ⓚ		UJ330	Brute Force Greaseable		UJ246
Brute Force Greaseable		UJ295	Clamp Kit (Rr. Shaft; Rr.)		UJ318-10
(For Aluminum Drive Shaft)		UJ330C	U-Joint (Wheel Joint)Ⓚ	[2]	UJ371
U-Joint (Wheel Joint)Ⓚ	[2]	UJ371	Brute Force Greaseable		UJ377
Brute Force Greaseable		UJ377	Brute Force Non Greaseable		UJ371
Brute Force Non Greaseable		UJ371	Ball Seat Repair Kit		UJ606
Ball Seat Repair Kit		UJ606	Flange Yoke		UJ626
Flange Yoke		UJ626	H Yoke		UJ646
H Yoke		UJ646			(Continued)

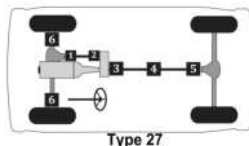
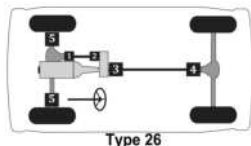

MFG./YEAR	MODEL & LOCATION	PART NO.	MFG./YEAR	MODEL & LOCATION	PART NO.
Drive Shaft (4 W/D) (Cont.)			Drive Shaft (4 W/D) (Cont.)		
U-Joint (Cont.)			U-Joint (Cont.)		
1991-1990 W350 w/ Rr. Shaft Inner Lock Rings & 1.375" Dia. Whl. Joint Brg. Caps:			1989-1988 W350 w/ Rr. Shaft Outer Lock Rings & 1.375" Dia. Whl. Joint Brg. Caps:		
[Type 26]			[Type 26]		
U-Joint (Frt. Shaft; Frt.) ^①		UJ317	U-Joint (Frt. Shaft; Frt.) ^①		UJ317
Brute Force Greaseable		UJ246	Brute Force Greaseable		UJ246
Clamp Kit (Frt. Shaft; Frt.)		UJ318-10	Clamp Kit (Frt. Shaft; Frt.)		UJ318-10
U-Joint (Frt. Shaft; Rr.) ^②	[2]	UJ534G	U-Joint (Frt. Shaft; Rr.) ^②	[2]	UJ534G
Brute Force Greaseable		UJ235	Brute Force Greaseable		UJ235
Brute Force Non Greaseable		UJ234	Brute Force Non Greaseable		UJ234
U-Joint (Rr. Shaft; Frt.) ^③		UJ317	U-Joint (Rr. Shaft; Frt.) ^③		UJ330
Brute Force Greaseable		UJ246	Brute Force Greaseable		UJ295
Clamp Kit (Rr. Shaft; Frt.)		UJ318-10	(For Aluminum Drive Shaft)		UJ330C
U-Joint (Rr. Shaft; Rr.) ^④		UJ317	Clamp Kit		UJ331-10
Brute Force Greaseable		UJ246	U-Joint (Rr. Shaft; Rr.) ^④		UJ330
Clamp Kit (Rr. Shaft; Rr.)		UJ318-10	Brute Force Greaseable		UJ295
U-Joint (Wheel Joint) ^⑤	[2]	UJ374	(For Aluminum Drive Shaft)		UJ330C
Brute Force Non Greaseable		UJ374BF	Clamp Kit		UJ331-10
Ball Seat Repair Kit		UJ606	U-Joint (Wheel Joint) ^⑤	[2]	UJ374
Flange Yoke		UJ626	Brute Force Non Greaseable		UJ374BF
H Yoke		UJ646	Ball Seat Repair Kit		UJ606
1991-1990 W350 w/ Rr. Shaft Outer Lock Rings & 1.188" Dia. Whl. Joint Brg. Caps:			1989-1988 W350 w/ Rr. Shaft Inner Lock Rings, 2.125" Rr. Yokes & 1.188" Dia. Whl. Joint Brg. Caps: [Type 26]		
[Type 26]			[Type 26]		
U-Joint (Frt. Shaft; Frt.) ^①		UJ317	U-Joint (Frt. Shaft; Frt.) ^①		UJ317
Brute Force Greaseable		UJ246	Brute Force Greaseable		UJ246
Clamp Kit (Frt. Shaft; Frt.)		UJ318-10	Clamp Kit (Frt. Shaft; Frt.)		UJ318-10
U-Joint (Frt. Shaft; Rr.) ^②	[2]	UJ534G	U-Joint (Frt. Shaft; Rr.) ^②	[2]	UJ534G
Brute Force Greaseable		UJ235	Brute Force Greaseable		UJ235
Brute Force Non Greaseable		UJ234	Brute Force Non Greaseable		UJ234
U-Joint (Rr. Shaft; Frt.) ^③		UJ330	U-Joint (Rr. Shaft; Frt.) ^③		UJ317
Brute Force Greaseable		UJ295	Brute Force Greaseable		UJ246
(For Aluminum Drive Shaft)		UJ330C	Clamp Kit (Rr. Shaft; Frt.)		UJ318-10
Clamp Kit		UJ331-10	U-Joint (Rr. Shaft; Rr.) ^④		UJ317
U-Joint (Rr. Shaft; Rr.) ^④		UJ330	Brute Force Greaseable		UJ246
Brute Force Greaseable		UJ295	Clamp Kit (Rr. Shaft; Rr.)		UJ318-10
(For Aluminum Drive Shaft)		UJ330C	U-Joint (Wheel Joint) ^⑤	[2]	UJ371
Clamp Kit		UJ331-10	Brute Force Greaseable		UJ377
U-Joint (Wheel Joint) ^⑤	[2]	UJ371	Brute Force Non Greaseable		UJ371
Brute Force Greaseable		UJ377	Ball Seat Repair Kit		UJ606
Brute Force Non Greaseable		UJ371	Flange Yoke		UJ626
Ball Seat Repair Kit		UJ606	H Yoke		UJ646
Flange Yoke		UJ626			
H Yoke		UJ646			

(Continued)

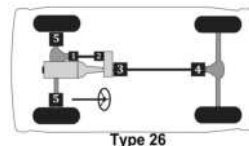

Passenger cars, light & medium trucks

Dodge Truck 1 ton -- (Cont.)

MFG./YEAR	MODEL & LOCATION	PART NO.	MFG./YEAR	MODEL & LOCATION	PART NO.
Drive Shaft (4 W/D) (Cont.)			Drive Shaft (4 W/D) (Cont.)		
U-Joint (Cont.)			U-Joint (Cont.)		
1989-1988 W350 w/ Rr. Shaft Inner Lock Rings, 2.125" Rr. Yokes & 1.375" Dia. Whl. Joint Brg. Caps: [Type 26]			1989-1988 W350 w/ Rr. Shaft Outer Lock Rings & 1.188" Dia. Whl. Joint Brg. Caps: [Type 26]		
U-Joint (Fr. Shaft; Frt.) [⊙]		UJ317	U-Joint (Fr. Shaft; Frt.) [⊙]		UJ317
Brute Force Greaseable		UJ246	Brute Force Greaseable		UJ246
Clamp Kit (Fr. Shaft; Frt.)		UJ318-10	Clamp Kit (Fr. Shaft; Frt.)		UJ318-10
U-Joint (Fr. Shaft; Rr.) [⊙]	[2]	UJ534G	U-Joint (Fr. Shaft; Rr.) [⊙]	[2]	UJ534G
Brute Force Greaseable		UJ235	Brute Force Greaseable		UJ235
Brute Force Non Greaseable		UJ234	Brute Force Non Greaseable		UJ234
U-Joint (Rr. Shaft; Frt.) [⊙]		UJ317	U-Joint (Rr. Shaft; Frt.) [⊙]		UJ330
Brute Force Greaseable		UJ246	Brute Force Greaseable		UJ295
Clamp Kit (Rr. Shaft; Frt.)		UJ318-10	(For Aluminum Drive Shaft)		UJ330C
U-Joint (Rr. Shaft; Rr.) [⊙]		UJ317	Clamp Kit		UJ331-10
Brute Force Greaseable		UJ246	U-Joint (Rr. Shaft; Rr.) [⊙]		UJ330
Clamp Kit (Rr. Shaft; Rr.)		UJ318-10	Brute Force Greaseable		UJ295
U-Joint (Wheel Joint) [⊙]	[2]	UJ374	(For Aluminum Drive Shaft)		UJ330C
Brute Force Non Greaseable		UJ374BF	Clamp Kit		UJ331-10
Ball Seat Repair Kit		UJ606	U-Joint (Wheel Joint) [⊙]	[2]	UJ371
Flange Yoke		UJ626	Brute Force Greaseable		UJ377
H Yoke		UJ646	Brute Force Non Greaseable		UJ371
			Ball Seat Repair Kit		UJ606
1989-1988 W350 w/ Rr. Shaft Inner Lock Rings, 3" Rr. Yokes & 1.188" Dia. Whl. Joint Brg. Caps: [Type 26]			Flange Yoke		UJ626
U-Joint (Fr. Shaft; Frt.) [⊙]		UJ317	H Yoke		UJ646
Brute Force Greaseable		UJ246	1987-1982 W350 w/ 3 Joint Rr. Shaft, 3" Rr. Axle Yoke & 1.375" Dia. Whl. Joint Brg. Caps: [Type 27]		
Clamp Kit (Fr. Shaft; Frt.)		UJ318-10	U-Joint (Fr. Shaft; Frt.) [⊙]		UJ315G
U-Joint (Fr. Shaft; Rr.) [⊙]	[2]	UJ534G	Brute Force Greaseable		UJ246
Brute Force Greaseable		UJ235	Clamp Kit (Fr. Shaft; Frt.)		UJ318-10
Brute Force Non Greaseable		UJ234	U-Joint (Fr. Shaft; Rr.) [⊙]	[2]	UJ534G
U-Joint (Rr. Shaft; Frt.) [⊙]		UJ304	Brute Force Greaseable		UJ235
U-Joint (Rr. Shaft; Rr.) [⊙]		UJ304	Brute Force Non Greaseable		UJ234
U-Joint (Wheel Joint) [⊙]	[2]	UJ371	U-Joint (Rr. Shaft; Frt.) [⊙]		UJ315G
Brute Force Greaseable		UJ377	Brute Force Greaseable		UJ246
Brute Force Non Greaseable		UJ371	Clamp Kit (Rr. Shaft; Frt.)		UJ318-10
Ball Seat Repair Kit		UJ606	U-Joint (Rr. Shaft; Ctr.) [⊙]		UJ315G
Flange Yoke		UJ626	Brute Force Greaseable		UJ246
H Yoke		UJ646	Clamp Kit (Rr. Shaft; Ctr.)		UJ318-10
1989-1988 W350 w/ Rr. Shaft Inner Lock Rings, 3" Rr. Yokes & 1.375" Dia. Whl. Joint Brg. Caps: [Type 26]			U-Joint (Rr. Shaft; Rr.) [⊙]		UJ304
U-Joint (Fr. Shaft; Frt.) [⊙]		UJ317	U-Joint (Wheel Joint) [⊙]	[2]	UJ374
Brute Force Greaseable		UJ246	Brute Force Non Greaseable		UJ374BF
Clamp Kit (Fr. Shaft; Frt.)		UJ318-10	Ball Seat Repair Kit		UJ606
U-Joint (Fr. Shaft; Rr.) [⊙]	[2]	UJ534G	Flange Yoke		UJ626
Brute Force Greaseable		UJ235	H Yoke		UJ646
Brute Force Non Greaseable		UJ234			(Continued)
U-Joint (Rr. Shaft; Frt.) [⊙]		UJ304			
U-Joint (Rr. Shaft; Rr.) [⊙]		UJ304			
U-Joint (Wheel Joint) [⊙]	[2]	UJ374			
Brute Force Non Greaseable		UJ374BF			
Ball Seat Repair Kit		UJ606			
Flange Yoke		UJ626			
H Yoke		UJ646			

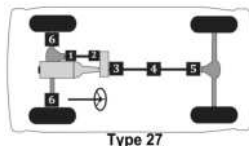
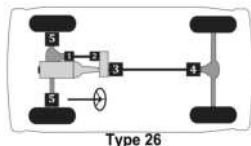

MFG./YEAR	MODEL & LOCATION	PART NO.	MFG./YEAR	MODEL & LOCATION	PART NO.
Drive Shaft (4 W/D) (Cont.)			Drive Shaft (4 W/D) (Cont.)		
U-Joint (Cont.)			U-Joint (Cont.)		
1987-1982 W350 w/ 2 Joint Rr. Shaft, 2.125" Rr. Axle Yoke & 1.188" Dia. Whl. Joint Brg. Caps: [Type 26]			1987-1982 W350 w/ 2 Joint Rr. Shaft, 3" Rr. Axle Yoke & 1.188" Dia. Whl. Joint Brg. Caps: [Type 26]		
U-Joint (Frnt. Shaft; Frnt.) ①		UJ315G	U-Joint (Frnt. Shaft; Frnt.) ①		UJ315G
Brute Force Greaseable		UJ246	Brute Force Greaseable		UJ246
Clamp Kit (Frnt. Shaft; Frnt.)		UJ318-10	Clamp Kit (Frnt. Shaft; Frnt.)		UJ318-10
U-Joint (Frnt. Shaft; Rr.) ②	[2]	UJ534G	U-Joint (Frnt. Shaft; Rr.) ②	[2]	UJ534G
Brute Force Greaseable		UJ235	Brute Force Greaseable		UJ235
Brute Force Non Greaseable		UJ234	Brute Force Non Greaseable		UJ234
U-Joint (Rr. Shaft; Frnt.) ③		UJ315G	U-Joint (Rr. Shaft; Frnt.) ③		UJ315G
Brute Force Greaseable		UJ246	Brute Force Greaseable		UJ246
Clamp Kit (Rr. Shaft; Frnt.)		UJ318-10	Clamp Kit (Rr. Shaft; Frnt.)		UJ318-10
U-Joint (Rr. Shaft; Rr.) ④		UJ315G	U-Joint (Rr. Shaft; Rr.) ④		UJ304
Brute Force Greaseable		UJ246	U-Joint (Wheel Joint) ⑤	[2]	UJ371
Clamp Kit (Rr. Shaft; Rr.)		UJ318-10	Brute Force Greaseable		UJ377
U-Joint (Wheel Joint) ⑥	[2]	UJ371	Brute Force Non Greaseable		UJ371
Brute Force Greaseable		UJ377	Ball Seat Repair Kit		UJ606
Brute Force Non Greaseable		UJ371	Flange Yoke		UJ626
Ball Seat Repair Kit		UJ606	H Yoke		UJ646
Flange Yoke		UJ626			
H Yoke		UJ646	1987-1982 W350 w/ 2 Joint Rr. Shaft, 3" Rr. Axle Yoke & 1.375" Dia. Whl. Joint Brg. Caps: [Type 26]		
1987-1982 W350 w/ 2 Joint Rr. Shaft, 2.125" Rr. Axle Yoke & 1.375" Dia. Whl. Joint Brg. Caps: [Type 26]			U-Joint (Frnt. Shaft; Frnt.) ①		UJ315G
U-Joint (Frnt. Shaft; Frnt.) ①		UJ315G	Brute Force Greaseable		UJ246
Brute Force Greaseable		UJ246	Clamp Kit (Frnt. Shaft; Frnt.)		UJ318-10
Clamp Kit (Frnt. Shaft; Frnt.)		UJ318-10	U-Joint (Frnt. Shaft; Rr.) ②	[2]	UJ534G
U-Joint (Frnt. Shaft; Rr.) ②	[2]	UJ534G	Brute Force Greaseable		UJ235
Brute Force Greaseable		UJ235	Brute Force Non Greaseable		UJ234
Brute Force Non Greaseable		UJ234	U-Joint (Rr. Shaft; Frnt.) ③		UJ315G
U-Joint (Rr. Shaft; Frnt.) ③		UJ315G	Brute Force Greaseable		UJ246
Brute Force Greaseable		UJ246	Clamp Kit (Rr. Shaft; Frnt.)		UJ318-10
Clamp Kit (Rr. Shaft; Frnt.)		UJ318-10	U-Joint (Rr. Shaft; Rr.) ④		UJ304
U-Joint (Rr. Shaft; Rr.) ④		UJ315G	U-Joint (Wheel Joint) ⑤	[2]	UJ374
Brute Force Greaseable		UJ246	Brute Force Non Greaseable		UJ374BF
Clamp Kit (Rr. Shaft; Rr.)		UJ318-10	Ball Seat Repair Kit		UJ606
U-Joint (Wheel Joint) ⑥	[2]	UJ374	Flange Yoke		UJ626
Brute Force Non Greaseable		UJ374BF	H Yoke		UJ646
Ball Seat Repair Kit		UJ606			
Flange Yoke		UJ626			
H Yoke		UJ646			

(Continued)

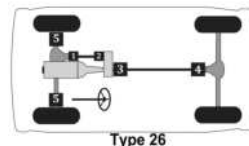

Passenger cars, light & medium trucks

Dodge Truck 1 ton -- (Cont.)

MFG./YEAR	MODEL & LOCATION	PART NO.	MFG./YEAR	MODEL & LOCATION	PART NO.
Drive Shaft (4 W/D) (Cont.)			Drive Shaft (4 W/D) (Cont.)		
U-Joint (Cont.)			U-Joint (Cont.)		
1987-1982 W350 w/ 3 Joint Rr. Shaft, 2.125" Rr. Axle Yoke & 1.188" Dia. Whl. Joint Brg. Caps: [Type 27]			1987-1982 W350 w/ 3 Joint Rr. Shaft, 3" Rr. Axle Yoke & 1.188" Dia. Whl. Joint Brg. Caps: [Type 27]		
U-Joint (Fr. Shaft; Frt.)ⓐ		UJ315G	U-Joint (Fr. Shaft; Frt.)ⓐ		UJ315G
Brute Force Greaseable		UJ246	Brute Force Greaseable		UJ246
Clamp Kit (Fr. Shaft; Frt.)		UJ318-10	Clamp Kit (Fr. Shaft; Frt.)		UJ318-10
U-Joint (Fr. Shaft; Rr.)ⓑ	[2]	UJ534G	U-Joint (Fr. Shaft; Rr.)ⓑ	[2]	UJ534G
Brute Force Greaseable		UJ235	Brute Force Greaseable		UJ235
Brute Force Non Greaseable		UJ234	Brute Force Non Greaseable		UJ234
U-Joint (Rr. Shaft; Frt.)ⓐ		UJ315G	U-Joint (Rr. Shaft; Frt.)ⓐ		UJ315G
Brute Force Greaseable		UJ246	Brute Force Greaseable		UJ246
Clamp Kit (Rr. Shaft; Frt.)		UJ318-10	Clamp Kit (Rr. Shaft; Frt.)		UJ318-10
U-Joint (Rr. Shaft; Ctr.)ⓐ		UJ315G	U-Joint (Rr. Shaft; Ctr.)ⓐ		UJ315G
Brute Force Greaseable		UJ246	Brute Force Greaseable		UJ246
Clamp Kit (Rr. Shaft; Ctr.)		UJ318-10	Clamp Kit (Rr. Shaft; Ctr.)		UJ318-10
U-Joint (Rr. Shaft; Rr.)ⓐ		UJ315G	U-Joint (Rr. Shaft; Rr.)ⓐ		UJ304
Brute Force Greaseable		UJ246	U-Joint (Wheel Joint)ⓐ	[2]	UJ371
Clamp Kit (Rr. Shaft; Rr.)		UJ318-10	Brute Force Greaseable		UJ377
U-Joint (Wheel Joint)ⓐ	[2]	UJ371	Brute Force Non Greaseable		UJ371
Brute Force Greaseable		UJ377	Ball Seat Repair Kit		UJ606
Brute Force Non Greaseable		UJ371	Flange Yoke		UJ626
Ball Seat Repair Kit		UJ606	H Yoke		UJ646
Flange Yoke		UJ626			
H Yoke		UJ646	1981-1977 W300 & W350 w/ 3 Joint Rr. Shaft, 2.625" Rr. Axle Yoke & 1.375" Dia. Whl. Joint Brg. Caps: [Type 27]		
1987-1982 W350 w/ 3 Joint Rr. Shaft, 2.125" Rr. Axle Yoke & 1.375" Dia. Whl. Joint Brg. Caps: [Type 27]			U-Joint (Fr. Shaft; Frt.)ⓐ		UJ315G
U-Joint (Fr. Shaft; Frt.)ⓐ		UJ315G	Brute Force Greaseable		UJ246
Brute Force Greaseable		UJ246	Clamp Kit (Fr. Shaft; Frt.)		UJ318-10
Clamp Kit (Fr. Shaft; Frt.)		UJ318-10	U-Joint (Fr. Shaft; Rr.)ⓑ	[2]	UJ534G
U-Joint (Fr. Shaft; Rr.)ⓑ	[2]	UJ534G	Brute Force Greaseable		UJ235
Brute Force Greaseable		UJ235	Brute Force Non Greaseable		UJ234
Brute Force Non Greaseable		UJ234	U-Joint (Rr. Shaft; Frt.)ⓐ		UJ315G
U-Joint (Rr. Shaft; Frt.)ⓐ		UJ315G	Brute Force Greaseable		UJ246
Brute Force Greaseable		UJ246	Clamp Kit (Rr. Shaft; Frt.)		UJ318-10
Clamp Kit (Rr. Shaft; Frt.)		UJ318-10	U-Joint (Rr. Shaft; Ctr.)ⓐ		UJ315G
U-Joint (Rr. Shaft; Ctr.)ⓐ		UJ315G	Brute Force Greaseable		UJ246
Brute Force Greaseable		UJ246	Clamp Kit (Rr. Shaft; Ctr.)		UJ318-10
Clamp Kit (Rr. Shaft; Ctr.)		UJ318-10	U-Joint (Rr. Shaft; Rr.)ⓐ		UJ316
U-Joint (Rr. Shaft; Rr.)ⓐ		UJ315G	Brute Force Greaseable		UJ248
Brute Force Greaseable		UJ246	Clamp Kit (Rr. Shaft; Rr.)		UJ316-10
Clamp Kit (Rr. Shaft; Rr.)		UJ318-10	U-Joint (Wheel Joint)ⓐ	[2]	UJ374
U-Joint (Wheel Joint)ⓐ	[2]	UJ374	Brute Force Non Greaseable		UJ374BF
Brute Force Non Greaseable		UJ374BF	Ball Seat Repair Kit		UJ606
Ball Seat Repair Kit		UJ606	Flange Yoke		UJ626
Flange Yoke		UJ626	H Yoke		UJ646
H Yoke		UJ646			(Continued)

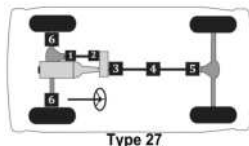

MFG./YEAR	MODEL & LOCATION	PART NO.	MFG./YEAR	MODEL & LOCATION	PART NO.
Drive Shaft (4 W/D) (Cont.)			Drive Shaft (4 W/D) (Cont.)		
U-Joint (Cont.)			U-Joint (Cont.)		
1981-1977 W300 & W350 w/ 2 Joint Rr. Shaft, 2.125" Rr. Axle Yoke & 1.188" Dia. Whl. Joint Brg. Caps: [Type 26]			1981-1977 W300 & W350 w/ 2 Joint Rr. Shaft, 2.625" Rr. Axle Yoke & 1.188" Dia. Whl. Joint Brg. Caps: [Type 26]		
U-Joint (Frnt. Shaft; Frnt.)		UJ315G	U-Joint (Frnt. Shaft; Frnt.)		UJ315G
Brute Force Greaseable		UJ246	Brute Force Greaseable		UJ246
Clamp Kit (Frnt. Shaft; Frnt.)		UJ318-10	Clamp Kit (Frnt. Shaft; Frnt.)		UJ318-10
U-Joint (Frnt. Shaft; Rr.)	[2]	UJ534G	U-Joint (Frnt. Shaft; Rr.)	[2]	UJ534G
Brute Force Greaseable		UJ235	Brute Force Greaseable		UJ235
Brute Force Non Greaseable		UJ234	Brute Force Non Greaseable		UJ234
U-Joint (Rr. Shaft; Frnt.)		UJ315G	U-Joint (Rr. Shaft; Frnt.)		UJ315G
Brute Force Greaseable		UJ246	Brute Force Greaseable		UJ246
Clamp Kit (Rr. Shaft; Frnt.)		UJ318-10	Clamp Kit (Rr. Shaft; Frnt.)		UJ318-10
U-Joint (Rr. Shaft; Rr.)		UJ315G	U-Joint (Rr. Shaft; Rr.)		UJ316
Brute Force Greaseable		UJ246	Brute Force Greaseable		UJ248
Clamp Kit (Rr. Shaft; Rr.)		UJ318-10	Clamp Kit (Rr. Shaft; Rr.)		UJ316-10
U-Joint (Wheel Joint)	[2]	UJ371	U-Joint (Wheel Joint)	[2]	UJ371
Brute Force Greaseable		UJ377	Brute Force Greaseable		UJ377
Brute Force Non Greaseable		UJ371	Brute Force Non Greaseable		UJ371
Ball Seat Repair Kit		UJ606	Ball Seat Repair Kit		UJ606
Flange Yoke		UJ626	Flange Yoke		UJ626
H Yoke		UJ646	H Yoke		UJ646
1981-1977 W300 & W350 w/ 2 Joint Rr. Shaft, 2.125" Rr. Axle Yoke & 1.375" Dia. Whl. Joint Brg. Caps: [Type 26]			1981-1977 W300 & W350 w/ 2 Joint Rr. Shaft, 2.625" Rr. Axle Yoke & 1.375" Dia. Whl. Joint Brg. Caps: [Type 26]		
U-Joint (Frnt. Shaft; Frnt.)		UJ315G	U-Joint (Frnt. Shaft; Frnt.)		UJ315G
Brute Force Greaseable		UJ246	Brute Force Greaseable		UJ246
Clamp Kit (Frnt. Shaft; Frnt.)		UJ318-10	Clamp Kit (Frnt. Shaft; Frnt.)		UJ318-10
U-Joint (Frnt. Shaft; Rr.)	[2]	UJ534G	U-Joint (Frnt. Shaft; Rr.)	[2]	UJ534G
Brute Force Greaseable		UJ235	Brute Force Greaseable		UJ235
Brute Force Non Greaseable		UJ234	Brute Force Non Greaseable		UJ234
U-Joint (Rr. Shaft; Frnt.)		UJ315G	U-Joint (Rr. Shaft; Frnt.)		UJ315G
Brute Force Greaseable		UJ246	Brute Force Greaseable		UJ246
Clamp Kit (Rr. Shaft; Frnt.)		UJ318-10	Clamp Kit (Rr. Shaft; Frnt.)		UJ318-10
U-Joint (Rr. Shaft; Rr.)		UJ315G	U-Joint (Rr. Shaft; Rr.)		UJ316
Brute Force Greaseable		UJ246	Brute Force Greaseable		UJ248
Clamp Kit (Rr. Shaft; Rr.)		UJ318-10	Clamp Kit (Rr. Shaft; Rr.)		UJ316-10
U-Joint (Wheel Joint)	[2]	UJ374	U-Joint (Wheel Joint)	[2]	UJ374
Brute Force Non Greaseable		UJ374BF	Brute Force Non Greaseable		UJ374BF
Ball Seat Repair Kit		UJ606	Ball Seat Repair Kit		UJ606
Flange Yoke		UJ626	Flange Yoke		UJ626
H Yoke		UJ646	H Yoke		UJ646

(Continued)

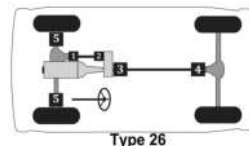

Passenger cars, light & medium trucks

Dodge Truck 1 ton -- (Cont.)

MFG./YEAR	MODEL & LOCATION	PART NO.	MFG./YEAR	MODEL & LOCATION	PART NO.
Drive Shaft (4 W/D) (Cont.)			Drive Shaft (4 W/D) (Cont.)		
U-Joint (Cont.)			U-Joint (Cont.)		
1981-1977 W300 & W350 w/ 3 Joint Rr. Shaft, 2.125" Rr. Axle Yoke & 1.188" Dia. Whl. Joint Brg. Caps: [Type 27]			1981-1977 W300 & W350 w/ 3 Joint Rr. Shaft, 2.625" Rr. Axle Yoke & 1.188" Dia. Whl. Joint Brg. Caps: [Type 27]		
U-Joint (Fr. Shaft; Frt.)ⓐ		UJ315G	U-Joint (Fr. Shaft; Frt.)ⓐ		UJ315G
Brute Force Greaseable		UJ246	Brute Force Greaseable		UJ246
Clamp Kit (Fr. Shaft; Frt.)		UJ318-10	Clamp Kit (Fr. Shaft; Frt.)		UJ318-10
U-Joint (Fr. Shaft; Rr.)ⓑ	[2]	UJ534G	U-Joint (Fr. Shaft; Rr.)ⓑ	[2]	UJ534G
Brute Force Greaseable		UJ235	Brute Force Greaseable		UJ235
Brute Force Non Greaseable		UJ234	Brute Force Non Greaseable		UJ234
U-Joint (Rr. Shaft; Frt.)ⓐ		UJ315G	U-Joint (Rr. Shaft; Frt.)ⓐ		UJ315G
Brute Force Greaseable		UJ246	Brute Force Greaseable		UJ246
Clamp Kit (Rr. Shaft; Frt.)		UJ318-10	Clamp Kit (Rr. Shaft; Frt.)		UJ318-10
U-Joint (Rr. Shaft; Ctr.)ⓐ		UJ315G	U-Joint (Rr. Shaft; Ctr.)ⓐ		UJ315G
Brute Force Greaseable		UJ246	Brute Force Greaseable		UJ246
Clamp Kit (Rr. Shaft; Ctr.)		UJ318-10	Clamp Kit (Rr. Shaft; Ctr.)		UJ318-10
U-Joint (Rr. Shaft; Rr.)ⓑ		UJ315G	U-Joint (Rr. Shaft; Rr.)ⓑ		UJ316
Brute Force Greaseable		UJ246	Brute Force Greaseable		UJ248
U-Joint (Wheel Joint)ⓐ	[2]	UJ371	Clamp Kit (Rr. Shaft; Rr.)		UJ316-10
Brute Force Greaseable		UJ377	U-Joint (Wheel Joint)ⓐ	[2]	UJ371
Brute Force Non Greaseable		UJ371	Brute Force Greaseable		UJ377
Ball Seat Repair Kit		UJ606	Brute Force Non Greaseable		UJ371
Flange Yoke		UJ626	Ball Seat Repair Kit		UJ606
H Yoke		UJ646	Flange Yoke		UJ626
			H Yoke		UJ646
1981-1977 W300 & W350 w/ 3 Joint Rr. Shaft, 2.125" Rr. Axle Yoke & 1.375" Dia. Whl. Joint Brg. Caps: [Type 27]			1976-1975 W300 w/ Frt. Shaft Outer Lock Rings, 3 Joint Rr. Shaft & 3" Rr. Axle Yoke: [Type 27]		
U-Joint (Fr. Shaft; Frt.)ⓐ		UJ315G	U-Joint (Fr. Shaft; Frt.)ⓐ		UJ315G
Brute Force Greaseable		UJ246	Brute Force Greaseable		UJ246
Clamp Kit (Fr. Shaft; Frt.)		UJ318-10	Clamp Kit (Fr. Shaft; Frt.)		UJ318-10
U-Joint (Fr. Shaft; Rr.)ⓑ	[2]	UJ534G	U-Joint (Fr. Shaft; Rr.)ⓑ	[2]	UJ379
Brute Force Greaseable		UJ235	Brute Force Greaseable		UJ280
Brute Force Non Greaseable		UJ234	Brute Force Non Greaseable		UJ269
U-Joint (Rr. Shaft; Frt.)ⓐ		UJ315G	U-Joint (Rr. Shaft; Frt.)ⓐ		UJ315G
Brute Force Greaseable		UJ246	Brute Force Greaseable		UJ246
Clamp Kit (Rr. Shaft; Frt.)		UJ318-10	Clamp Kit (Rr. Shaft; Frt.)		UJ318-10
U-Joint (Rr. Shaft; Ctr.)ⓐ		UJ315G	U-Joint (Rr. Shaft; Ctr.)ⓐ		UJ315G
Brute Force Greaseable		UJ246	Brute Force Greaseable		UJ246
Clamp Kit (Rr. Shaft; Ctr.)		UJ318-10	Clamp Kit (Rr. Shaft; Ctr.)		UJ318-10
U-Joint (Rr. Shaft; Rr.)ⓑ		UJ315G	U-Joint (Rr. Shaft; Rr.)ⓑ		UJ304
Brute Force Greaseable		UJ246	U-Joint (Wheel Joint)ⓐ	[2]	UJ371
Clamp Kit (Rr. Shaft; Rr.)		UJ318-10	Brute Force Greaseable		UJ377
U-Joint (Wheel Joint)ⓐ	[2]	UJ374	Brute Force Non Greaseable		UJ371
Brute Force Non Greaseable		UJ374BF	Centering Yoke		UJ607
Ball Seat Repair Kit		UJ606	H Yoke		UJ647
Flange Yoke		UJ626			
H Yoke		UJ646			

(Continued)

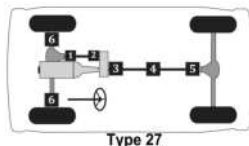

MFG./YEAR	MODEL & LOCATION	PART NO.	MFG./YEAR	MODEL & LOCATION	PART NO.
Drive Shaft (4 W/D) (Cont.)			Drive Shaft (4 W/D) (Cont.)		
U-Joint (Cont.)			U-Joint (Cont.)		
1976-1975 W300 w/ Frt. Shaft Inner Lock Rings, 2 Joint Rr. Shaft & 2.125" Rr. Axle Yoke: [Type 26]			1976-1975 W300 w/ Frt. Shaft Outer Lock Rings, 3 Joint Rr. Shaft & 2.625" Rr. Axle Yoke: [Type 27]		
U-Joint (Frt. Shaft; Frt.) ①		UJ315G	U-Joint (Frt. Shaft; Frt.) ①		UJ315G
Brute Force Greaseable		UJ246	Brute Force Greaseable		UJ246
Clamp Kit (Frt. Shaft; Frt.)		UJ318-10	Clamp Kit (Frt. Shaft; Frt.)		UJ318-10
U-Joint (Frt. Shaft; Rr.) ②	[2]	UJ534G	U-Joint (Frt. Shaft; Rr.) ②	[2]	UJ379
Brute Force Greaseable		UJ235	Brute Force Greaseable		UJ280
Brute Force Non Greaseable		UJ234	Brute Force Non Greaseable		UJ269
U-Joint (Rr. Shaft; Frt.) ③		UJ315G	U-Joint (Rr. Shaft; Frt.) ③		UJ315G
Brute Force Greaseable		UJ246	Brute Force Greaseable		UJ246
Clamp Kit (Rr. Shaft; Frt.)		UJ318-10	Clamp Kit (Rr. Shaft; Frt.)		UJ318-10
U-Joint (Rr. Shaft; Rr.) ④		UJ315G	U-Joint (Rr. Shaft; Ctr.) ④		UJ315G
Brute Force Greaseable		UJ246	Brute Force Greaseable		UJ246
U-Joint (Wheel Joint) ⑤	[2]	UJ371	Clamp Kit (Rr. Shaft; Ctr.)		UJ318-10
Brute Force Greaseable		UJ377	U-Joint (Rr. Shaft; Rr.) ⑤		UJ316
Brute Force Non Greaseable		UJ371	Brute Force Greaseable		UJ248
Ball Seat Repair Kit		UJ606	Clamp Kit (Rr. Shaft; Rr.)		UJ316-10
Flange Yoke		UJ626	U-Joint (Wheel Joint) ⑥	[2]	UJ371
H Yoke		UJ646	Brute Force Greaseable		UJ377
1976-1975 W300 w/ Frt. Shaft Inner Lock Rings, 2 Joint Rr. Shaft & 3" Rr. Axle Yoke: [Type 26]			1976-1975 W300 w/ Frt. Shaft Inner Lock Rings, 2 Joint Rr. Shaft & 2.625" Rr. Axle Yoke: [Type 27]		
U-Joint (Frt. Shaft; Frt.) ①		UJ315G	U-Joint (Frt. Shaft; Frt.) ①		UJ315G
Brute Force Greaseable		UJ246	Brute Force Greaseable		UJ246
Clamp Kit (Frt. Shaft; Frt.)		UJ318-10	Clamp Kit (Frt. Shaft; Frt.)		UJ318-10
U-Joint (Frt. Shaft; Rr.) ②	[2]	UJ534G	U-Joint (Frt. Shaft; Rr.) ②	[2]	UJ534G
Brute Force Greaseable		UJ235	Brute Force Greaseable		UJ235
Brute Force Non Greaseable		UJ234	Brute Force Non Greaseable		UJ234
U-Joint (Rr. Shaft; Frt.) ③		UJ315G	U-Joint (Rr. Shaft; Frt.) ③		UJ315G
Brute Force Greaseable		UJ246	Brute Force Greaseable		UJ246
Clamp Kit (Rr. Shaft; Frt.)		UJ318-10	Clamp Kit (Rr. Shaft; Frt.)		UJ318-10
U-Joint (Rr. Shaft; Rr.) ④		UJ304	U-Joint (Rr. Shaft; Ctr.) ④		UJ315G
U-Joint (Wheel Joint) ⑤	[2]	UJ371	Brute Force Greaseable		UJ246
Brute Force Greaseable		UJ377	Clamp Kit (Rr. Shaft; Ctr.)		UJ318-10
Brute Force Non Greaseable		UJ371	U-Joint (Rr. Shaft; Rr.) ⑤		UJ316
Ball Seat Repair Kit		UJ606	Brute Force Greaseable		UJ248
Flange Yoke		UJ626	Clamp Kit (Rr. Shaft; Rr.)		UJ316-10
H Yoke		UJ646	U-Joint (Wheel Joint) ⑥	[2]	UJ371
			Brute Force Greaseable		UJ377
			Brute Force Non Greaseable		UJ371
			Ball Seat Repair Kit		UJ606
			Flange Yoke		UJ626
			H Yoke		UJ646

(Continued)

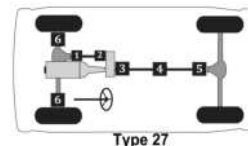
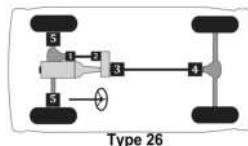

Passenger cars, light & medium trucks

Dodge Truck 1 ton -- (Cont.)

MFG./YEAR	MODEL & LOCATION	PART NO.	MFG./YEAR	MODEL & LOCATION	PART NO.
Drive Shaft (4 W/D) (Cont.)			Drive Shaft (4 W/D) (Cont.)		
U-Joint (Cont.)			U-Joint (Cont.)		
1976-1975 W300 w/ Frt. Shaft Outer Lock Rings, 3 Joint Rr. Shaft & 2.125" Rr. Axle Yoke: [Type 27]			1976-1975 W300 w/ Frt. Shaft Outer Lock Rings, 2 Joint Rr. Shaft & 2.625" Rr. Axle Yoke: [Type 26]		
U-Joint (Frt. Shaft; Frt.)ⓐ		UJ315G	U-Joint (Frt. Shaft; Frt.)ⓐ		UJ315G
Brute Force Greaseable		UJ246	Brute Force Greaseable		UJ246
Clamp Kit (Frt. Shaft; Frt.)		UJ318-10	Clamp Kit (Frt. Shaft; Frt.)		UJ318-10
U-Joint (Frt. Shaft; Rr.)ⓑ	[2]	UJ379	U-Joint (Frt. Shaft; Rr.)ⓑ	[2]	UJ379
Brute Force Greaseable		UJ280	Brute Force Greaseable		UJ280
Brute Force Non Greaseable		UJ269	Brute Force Non Greaseable		UJ269
U-Joint (Rr. Shaft; Frt.)ⓐ		UJ315G	U-Joint (Rr. Shaft; Frt.)ⓐ		UJ315G
Brute Force Greaseable		UJ246	Brute Force Greaseable		UJ246
Clamp Kit (Rr. Shaft; Frt.)		UJ318-10	Clamp Kit (Rr. Shaft; Frt.)		UJ318-10
U-Joint (Rr. Shaft; Ctr.)ⓐ		UJ315G	U-Joint (Rr. Shaft; Rr.)ⓐ		UJ316
Brute Force Greaseable		UJ246	Brute Force Greaseable		UJ248
Clamp Kit (Rr. Shaft; Ctr.)		UJ318-10	Clamp Kit (Rr. Shaft; Rr.)		UJ316-10
U-Joint (Rr. Shaft; Rr.)ⓑ		UJ315G	U-Joint (Wheel Joint)ⓐ	[2]	UJ371
Brute Force Greaseable		UJ246	Brute Force Greaseable		UJ377
Clamp Kit (Rr. Shaft; Rr.)		UJ318-10	Brute Force Non Greaseable		UJ371
U-Joint (Wheel Joint)ⓐ	[2]	UJ371	Centering Yoke		UJ607
Brute Force Greaseable		UJ377	H Yoke		UJ647
Brute Force Non Greaseable		UJ371	1976-1975 W300 w/ Frt. Shaft Outer Lock Rings, 2 Joint Rr. Shaft & 2.125" Rr. Axle Yoke: [Type 26]		
Centering Yoke		UJ607	U-Joint (Frt. Shaft; Frt.)ⓐ		UJ315G
1976-1975 W300 w/ Frt. Shaft Outer Lock Rings, 2 Joint Rr. Shaft & 3" Rr. Axle Yoke: [Type 26]			Brute Force Greaseable		UJ246
U-Joint (Frt. Shaft; Frt.)ⓐ		UJ315G	Clamp Kit (Frt. Shaft; Frt.)		UJ318-10
Brute Force Greaseable		UJ246	U-Joint (Frt. Shaft; Rr.)ⓑ	[2]	UJ379
Clamp Kit (Frt. Shaft; Frt.)		UJ318-10	Brute Force Greaseable		UJ280
U-Joint (Frt. Shaft; Rr.)ⓑ	[2]	UJ379	Brute Force Non Greaseable		UJ269
Brute Force Greaseable		UJ280	U-Joint (Rr. Shaft; Frt.)ⓐ		UJ315G
Brute Force Non Greaseable		UJ269	Brute Force Greaseable		UJ246
U-Joint (Rr. Shaft; Frt.)ⓐ		UJ315G	Clamp Kit (Rr. Shaft; Frt.)		UJ318-10
Brute Force Greaseable		UJ246	U-Joint (Rr. Shaft; Rr.)ⓐ		UJ315G
Clamp Kit (Rr. Shaft; Frt.)		UJ318-10	Brute Force Greaseable		UJ246
U-Joint (Rr. Shaft; Rr.)ⓐ		UJ304	Clamp Kit (Rr. Shaft; Rr.)		UJ318-10
U-Joint (Wheel Joint)ⓐ	[2]	UJ371	U-Joint (Wheel Joint)ⓐ	[2]	UJ371
Brute Force Greaseable		UJ377	Brute Force Greaseable		UJ377
Brute Force Non Greaseable		UJ371	Brute Force Non Greaseable		UJ371
Centering Yoke		UJ607	Centering Yoke		UJ607
			H Yoke		UJ647
					(Continued)

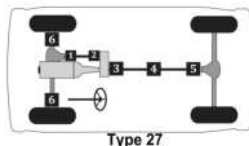
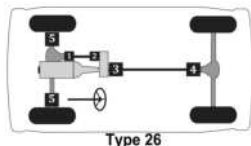

MFG./YEAR	MODEL & LOCATION	PART NO.	MFG./YEAR	MODEL & LOCATION	PART NO.
Drive Shaft (4 W/D) (Cont.)			Drive Shaft (4 W/D) (Cont.)		
U-Joint (Cont.)			U-Joint (Cont.)		
1976-1975 W300 w/ Frt. Shaft Inner Lock Rings, 3 Joint Rr. Shaft & 3" Rr. Axle Yoke:			1976-1975 W300 w/ Frt. Shaft Inner Lock Rings, 3 Joint Rr. Shaft & 2.625" Rr. Axle Yoke:		
[Type 27]			[Type 27]		
U-Joint (Frt. Shaft; Frt.) ^①		UJ315G	U-Joint (Frt. Shaft; Frt.) ^①		UJ315G
Brute Force Greaseable		UJ246	Brute Force Greaseable		UJ246
Clamp Kit (Frt. Shaft; Frt.)		UJ318-10	Clamp Kit (Frt. Shaft; Frt.)		UJ318-10
U-Joint (Frt. Shaft; Rr.) ^②	[2]	UJ534G	U-Joint (Frt. Shaft; Rr.) ^②	[2]	UJ534G
Brute Force Greaseable		UJ235	Brute Force Greaseable		UJ235
Brute Force Non Greaseable		UJ234	Brute Force Non Greaseable		UJ234
U-Joint (Rr. Shaft; Frt.) ^③		UJ315G	U-Joint (Rr. Shaft; Frt.) ^③		UJ315G
Brute Force Greaseable		UJ246	Brute Force Greaseable		UJ246
Clamp Kit (Rr. Shaft; Frt.)		UJ318-10	Clamp Kit (Rr. Shaft; Frt.)		UJ318-10
U-Joint (Rr. Shaft; Ctr.) ^④		UJ315G	U-Joint (Rr. Shaft; Ctr.) ^④		UJ315G
Brute Force Greaseable		UJ246	Brute Force Greaseable		UJ246
Clamp Kit (Rr. Shaft; Ctr.)		UJ318-10	Clamp Kit (Rr. Shaft; Ctr.)		UJ318-10
U-Joint (Rr. Shaft; Rr.) ^⑤		UJ304	U-Joint (Rr. Shaft; Rr.) ^⑤		UJ316
U-Joint (Wheel Joint) ^⑥	[2]	UJ371	Brute Force Greaseable		UJ248
Brute Force Greaseable		UJ377	Clamp Kit (Rr. Shaft; Rr.)		UJ316-10
Brute Force Non Greaseable		UJ371	U-Joint (Wheel Joint) ^⑥	[2]	UJ371
Ball Seat Repair Kit		UJ606	Brute Force Greaseable		UJ377
Flange Yoke		UJ626	Brute Force Non Greaseable		UJ371
H Yoke		UJ646	Ball Seat Repair Kit		UJ606
1976-1975 W300 w/ Frt. Shaft Inner Lock Rings, 3 Joint Rr. Shaft & 2.125" Rr. Axle Yoke:			Flange Yoke		UJ626
[Type 27]			H Yoke		UJ646
U-Joint (Frt. Shaft; Frt.) ^①		UJ315G	1974-1960 W300 w/ 3" Yokes: [Type 34]		
Brute Force Greaseable		UJ246	U-Joint (Frt. Shaft; Frt.) ^①		UJ304
Clamp Kit (Frt. Shaft; Frt.)		UJ318-10	U-Joint (Frt. Shaft; Rr.) ^②		UJ304
U-Joint (Frt. Shaft; Rr.) ^②	[2]	UJ534G	U-Joint (Intmd. Shaft; Frt.) ^③		UJ304
Brute Force Greaseable		UJ235	U-Joint (Intmd. Shaft; Rr.) ^④		UJ304
Brute Force Non Greaseable		UJ234	U-Joint (Rr. Shaft; Frt.) ^⑤		UJ304
U-Joint (Rr. Shaft; Frt.) ^③		UJ315G	U-Joint (Rr. Shaft; Rr.) ^⑥		UJ304
Brute Force Greaseable		UJ246	1974-1960 W300 w/ 2" Yokes: [Type 34]		
Clamp Kit (Rr. Shaft; Frt.)		UJ318-10	U-Joint (Frt. Shaft; Frt.) ^①		UJ305
U-Joint (Rr. Shaft; Ctr.) ^④		UJ315G	U-Joint (Frt. Shaft; Rr.) ^②		UJ305
Brute Force Greaseable		UJ246	U-Joint (Intmd. Shaft; Frt.) ^③		UJ305
Clamp Kit (Rr. Shaft; Ctr.)		UJ318-10	U-Joint (Intmd. Shaft; Rr.) ^④		UJ305
U-Joint (Rr. Shaft; Rr.) ^⑤		UJ315G	U-Joint (Rr. Shaft; Frt.) ^⑤		UJ305
Brute Force Greaseable		UJ246	U-Joint (Rr. Shaft; Rr.) ^⑥		UJ305
Clamp Kit (Rr. Shaft; Rr.)		UJ316-10			
U-Joint (Wheel Joint) ^⑥	[2]	UJ371			
Brute Force Greaseable		UJ377			
Brute Force Non Greaseable		UJ371			
Ball Seat Repair Kit		UJ606			
Flange Yoke		UJ626			
H Yoke		UJ646			

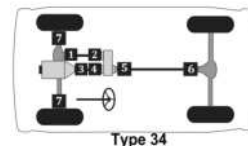
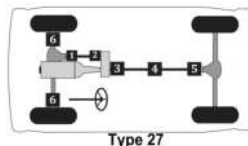

Passenger cars, light & medium trucks

Dodge Truck US & Canada, 1 1/2 ton, 2 ton

MFG./YEAR	MODEL & LOCATION	PART NO.	MFG./YEAR	MODEL & LOCATION	PART NO.
Drive Shaft (4 X 2)			Drive Shaft (4 X 4)		
U-Joint			U-Joint		
2010-2008 R4500 & R5500 w/ 2 Joint Shaft:			2010-2008 R4500 & R5500 w/ 2 Joint Shaft:		
[Type 1]			[Type 13]		
U-Joint (Front)Ⓛ		UJ358	U-Joint (Fr. Shaft; Frt.)Ⓛ		UJ331
Brute Force Non Greaseable		UJ358BF	Brute Force Greaseable		UJ232
U-Joint (Rear)Ⓛ		UJ358	Brute Force Non Greaseable		UJ231
Brute Force Non Greaseable		UJ358BF	(For Aluminum Drive Shaft)		UJ331C
2010-2008 R4500 & R5500 w/ 3 Joint Shaft:			U-Joint (Fr. Shaft; Rr.)Ⓛ [2]		
[Type 2]			Brute Force Greaseable		
U-Joint (Front)Ⓛ		UJ358			UJ232
Brute Force Non Greaseable		UJ358BF	Brute Force Non Greaseable		UJ231
U-Joint (Center)Ⓛ		UJ358	(For Aluminum Drive Shaft)		UJ331C
Brute Force Non Greaseable		UJ358BF	U-Joint (Rr. Shaft; Frt.)Ⓛ		UJ358
U-Joint (Rear)Ⓛ		UJ358	Brute Force Non Greaseable		UJ358BF
Brute Force Non Greaseable		UJ358BF	U-Joint (Rr. Shaft; Rr.)Ⓛ		UJ358
2010-2008 R4500 & R5500 w/ 4 Joint Shaft:			Brute Force Non Greaseable		
[Type 3]			U-Joint (Rr. Shaft; Rr.)Ⓛ		
U-Joint (Front)Ⓛ		UJ358			UJ358BF
Brute Force Non Greaseable		UJ358BF	H Yoke		UJ650
U-Joint (Center; Front)Ⓛ		UJ358	2010-2008 R4500 & R5500 w/ 3 Joint Shaft:		
Brute Force Non Greaseable		UJ358BF	[Type 14]		
U-Joint (Center; Rear)Ⓛ		UJ358	U-Joint (Fr. Shaft; Frt.)Ⓛ		UJ331
Brute Force Non Greaseable		UJ358BF	Brute Force Greaseable		UJ232
U-Joint (Rear)Ⓛ		UJ358	Brute Force Non Greaseable		UJ231
Brute Force Non Greaseable		UJ358BF	(For Aluminum Drive Shaft)		UJ331C
			U-Joint (Fr. Shaft; Rr.)Ⓛ [2]		UJ331
			Brute Force Greaseable		UJ232
			Brute Force Non Greaseable		UJ231
			(For Aluminum Drive Shaft)		UJ331C
			U-Joint (Rr. Shaft; Frt.)Ⓛ		UJ358
			Brute Force Non Greaseable		UJ358BF
			U-Joint (Rr. Shaft; Ctr.)Ⓛ		UJ358
			Brute Force Non Greaseable		UJ358BF
			U-Joint (Rr. Shaft; Rr.)Ⓛ		UJ358
			Brute Force Non Greaseable		UJ358BF
			H Yoke		UJ650

Ford CUV Escape

Drive Shaft (4 W/D)

U-Joint

2012-2001 Escape: [Type 43]

U-Joint (Rr. Shaft; Ctr.)Ⓛ	UJ369
Brute Force Greaseable	UJ280
Brute Force Non Greaseable	UJ269
(For Aluminum Drive Shaft)	UJ369C
U-Joint (Rr. Shaft; Rr.)Ⓛ	UJ369
Brute Force Greaseable	UJ280
Brute Force Non Greaseable	UJ269
(For Aluminum Drive Shaft)	UJ369C

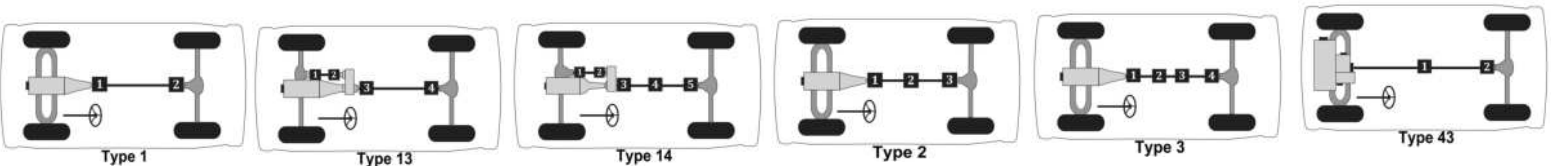

SKF

Passenger cars, light & medium trucks

Ford Truck Aerostar, Bronco II, Excursion, Expedition, Explorer (thru 2010), Explorer Sport Trac, Ranger

MFG./YEAR	MODEL & LOCATION	PART NO.	MFG./YEAR	MODEL & LOCATION	PART NO.
Drive Shaft (2 W/D)			Drive Shaft (2 W/D) (Cont.)		
U-Joint			U-Joint (Cont.)		
2021-2007 Expedition: [Type 6]			2003-2000 Excursion w/ 4" Yoke: [Type 1]		
	U-Joint (Center)Ⓢ	UJ331		U-Joint (Front)Ⓢ	UJ331
	Brute Force Greaseable	UJ232		Brute Force Greaseable	UJ232
	Brute Force Non Greaseable	UJ231		Brute Force Non Greaseable	UJ231
	(For Aluminum Drive Shaft)	UJ331C		(For Aluminum Drive Shaft)	UJ331C
	U-Joint (Rear)Ⓢ	UJ331		U-Joint (Rear)Ⓢ	UJ331
	Brute Force Greaseable	UJ232		Brute Force Greaseable	UJ232
	Brute Force Non Greaseable	UJ231		Brute Force Non Greaseable	UJ231
	(For Aluminum Drive Shaft)	UJ331C		(For Aluminum Drive Shaft)	UJ331C
2011-1998 Ranger: [Type 1]			2003-2000 Excursion w/ 4.5" Yoke: [Type 1]		
	U-Joint (Front)Ⓢ	UJ354		U-Joint (Front)Ⓢ	UJ330
	Brute Force Greaseable	UJ270		Brute Force Greaseable	UJ295
	Brute Force Non Greaseable	UJ254		(For Aluminum Drive Shaft)	UJ330C
	(For Aluminum Drive Shaft)	UJ354C		U-Joint (Rear)Ⓢ	UJ330
	U-Joint (Rear)Ⓢ	UJ354		Brute Force Greaseable	UJ295
	Brute Force Greaseable	UJ270		(For Aluminum Drive Shaft)	UJ330C
	Brute Force Non Greaseable	UJ254		2002 Expedition: [Type 1]	
	(For Aluminum Drive Shaft)	UJ354C		U-Joint (Front)Ⓢ	UJ331
2010-2007 Explorer Exc. Sport Trac: [Type 1]				Brute Force Greaseable	UJ232
	U-Joint (Front)Ⓢ	UJ354		Brute Force Non Greaseable	UJ231
	Brute Force Greaseable	UJ270		(For Aluminum Drive Shaft)	UJ331C
	Brute Force Non Greaseable	UJ254		U-Joint (Rear)Ⓢ	UJ331
	(For Aluminum Drive Shaft)	UJ354C		Brute Force Greaseable	UJ232
	U-Joint (Rear)Ⓢ	UJ354		Brute Force Non Greaseable	UJ231
	Brute Force Greaseable	UJ270		(For Aluminum Drive Shaft)	UJ331C
	Brute Force Non Greaseable	UJ254		2001-1997 Expedition w/ 4.6L Eng.: [Type 1]	
	(For Aluminum Drive Shaft)	UJ354C		U-Joint (Front)Ⓢ	UJ354
2006-2003 Expedition: [Type 7]				Brute Force Greaseable	UJ270
	U-Joint (Rear)Ⓢ	UJ331		Brute Force Non Greaseable	UJ254
	Brute Force Greaseable	UJ232		(For Aluminum Drive Shaft)	UJ354C
	Brute Force Non Greaseable	UJ231		U-Joint (Rear)Ⓢ	UJ354
	(For Aluminum Drive Shaft)	UJ331C		Brute Force Greaseable	UJ270
2006-1997 Explorer & Explorer Sport Trac:				Brute Force Non Greaseable	UJ254
	[Type 1]			(For Aluminum Drive Shaft)	UJ354C
	U-Joint (Front)Ⓢ	UJ354	2001-1997 Expedition w/ 5.4L Eng.: [Type 1]		
	Brute Force Greaseable	UJ270		U-Joint (Front)Ⓢ	UJ331
	Brute Force Non Greaseable	UJ254		Brute Force Greaseable	UJ232
	(For Aluminum Drive Shaft)	UJ354C		Brute Force Non Greaseable	UJ231
	U-Joint (Rear)Ⓢ	UJ354		(For Aluminum Drive Shaft)	UJ331C
	Brute Force Greaseable	UJ270		U-Joint (Rear)Ⓢ	UJ331
	Brute Force Non Greaseable	UJ254		Brute Force Greaseable	UJ232
	(For Aluminum Drive Shaft)	UJ354C		Brute Force Non Greaseable	UJ231
2005-2004 Excursion: [Type 1]				(For Aluminum Drive Shaft)	UJ331C
	U-Joint (Front)Ⓢ	UJ330		(Continued)	
	Brute Force Greaseable	UJ295			
	(For Aluminum Drive Shaft)	UJ330C			
	U-Joint (Rear)Ⓢ	UJ330			
	Brute Force Greaseable	UJ295			
	(For Aluminum Drive Shaft)	UJ330C			

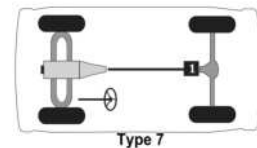
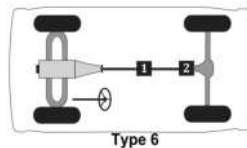
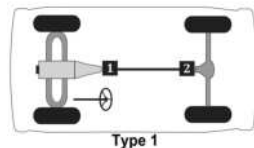

Passenger cars, light & medium trucks

Ford Truck Aerostar, Bronco II, Excursion, Expedition, Explorer (thru 2010), Explorer Sport Trac, Ranger -- (Cont.)

MFG./YEAR	MODEL & LOCATION	PART NO.	MFG./YEAR	MODEL & LOCATION	PART NO.
Drive Shaft (2 W/D) (Cont.)			Drive Shaft (2 W/D) (Cont.)		
U-Joint (Cont.)			U-Joint (Cont.)		
1997	Aerostar w/ Auto. Trans. & 3.5" Yoke:		1997-1990	Ranger w/ 3 Joint Shaft: [Type 2]	
	[Type 1]		U-Joint (Front)ⓐ		UJ369
	U-Joint (Front)ⓐ	UJ369	Brute Force Greaseable		UJ280
	Brute Force Greaseable	UJ280	Brute Force Non Greaseable		UJ269
	Brute Force Non Greaseable	UJ269	(For Aluminum Drive Shaft)		UJ369C
	(For Aluminum Drive Shaft)	UJ369C	Clamp Kit (Front)		UJ437-10
	U-Joint (Rear)ⓑ	UJ369	U-Joint (Center)ⓑ		UJ369
	Brute Force Greaseable	UJ280	Brute Force Greaseable		UJ280
	Brute Force Non Greaseable	UJ269	Brute Force Non Greaseable		UJ269
	(For Aluminum Drive Shaft)	UJ369C	(For Aluminum Drive Shaft)		UJ369C
	1997 Aerostar w/ Auto. Trans. & 3.875" Yoke: [Type 1]		Clamp Kit (Center)		UJ437-10
	U-Joint (Front)ⓐ	UJ354	U-Joint (Rear)ⓑ		UJ369
	Brute Force Greaseable	UJ270	Brute Force Greaseable		UJ280
	Brute Force Non Greaseable	UJ254	Brute Force Non Greaseable		UJ269
	(For Aluminum Drive Shaft)	UJ354C	(For Aluminum Drive Shaft)		UJ369C
	U-Joint (Rear)ⓑ	UJ354	Clamp Kit (Rear)		UJ437-10
	Brute Force Greaseable	UJ270	1996 Aerostar w/ Auto. Trans.: [Type 1]		
	Brute Force Non Greaseable	UJ254	U-Joint (Front)ⓐ		UJ354
	(For Aluminum Drive Shaft)	UJ354C	Brute Force Greaseable		UJ270
	1997-1996 Aerostar w/ Man. Trans.: [Type 1]		Brute Force Non Greaseable		UJ254
	U-Joint (Front)ⓐ	UJ369	(For Aluminum Drive Shaft)		UJ354C
	Brute Force Greaseable	UJ280	U-Joint (Rear)ⓑ		UJ354
	Brute Force Non Greaseable	UJ269	Brute Force Greaseable		UJ270
	(For Aluminum Drive Shaft)	UJ369C	Brute Force Non Greaseable		UJ254
	U-Joint (Rear)ⓑ	UJ369	(For Aluminum Drive Shaft)		UJ354C
	Brute Force Greaseable	UJ280	1996-1995 Explorer w/ 3.5" Yoke: [Type 1]		
	Brute Force Non Greaseable	UJ269	U-Joint (Front)ⓐ		UJ369
	(For Aluminum Drive Shaft)	UJ369C	Brute Force Greaseable		UJ280
	1997-1990 Ranger w/ 2 Joint Shaft: [Type 1]		Brute Force Non Greaseable		UJ269
	U-Joint (Front)ⓐ	UJ369	(For Aluminum Drive Shaft)		UJ369C
	Brute Force Greaseable	UJ280	U-Joint (Rear)ⓑ		UJ369
	Brute Force Non Greaseable	UJ269	Brute Force Greaseable		UJ280
	(For Aluminum Drive Shaft)	UJ369C	Brute Force Non Greaseable		UJ269
	Clamp Kit (Front)	UJ437-10	(For Aluminum Drive Shaft)		UJ369C
	U-Joint (Rear)ⓑ	UJ369	1996-1995 Explorer w/ 3.875" Yoke: [Type 1]		
	Brute Force Greaseable	UJ280	U-Joint (Front)ⓐ		UJ354
	Brute Force Non Greaseable	UJ269	Brute Force Greaseable		UJ270
	(For Aluminum Drive Shaft)	UJ369C	Brute Force Non Greaseable		UJ254
	Clamp Kit (Rear)	UJ437-10	(For Aluminum Drive Shaft)		UJ354C
			U-Joint (Rear)ⓑ		UJ354
			Brute Force Greaseable		UJ270
			Brute Force Non Greaseable		UJ254
			(For Aluminum Drive Shaft)		UJ354C
			(Continued)		

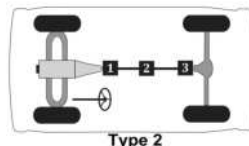
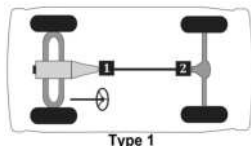

Passenger cars, light & medium trucks

(Cont.) -- Ford Truck Aerostar, Bronco II, Excursion, Expedition, Explorer (thru 2010), Explorer Sport Trac, Ranger

MFG./YEAR	MODEL & LOCATION	PART NO.	MFG./YEAR	MODEL & LOCATION	PART NO.
Drive Shaft (2 W/D) (Cont.)			Drive Shaft (2 W/D) (Cont.)		
U-Joint (Cont.)			U-Joint (Cont.)		
1995-1990 Aerostar: [Type 1]			1985-1983 Ranger: [Type 1]		
	U-Joint (Front)Ⓢ	UJ369		U-Joint (Front)Ⓢ	UJ369
	Brute Force Greaseable	UJ280		Brute Force Greaseable	UJ280
	Brute Force Non Greaseable	UJ269		Brute Force Non Greaseable	UJ269
	(For Aluminum Drive Shaft)	UJ369C		(For Aluminum Drive Shaft)	UJ369C
	U-Joint (Rear)Ⓢ	UJ369		U-Joint (Rear)Ⓢ	UJ369
	Brute Force Greaseable	UJ280		Brute Force Greaseable	UJ280
	Brute Force Non Greaseable	UJ269		Brute Force Non Greaseable	UJ269
	(For Aluminum Drive Shaft)	UJ369C		(For Aluminum Drive Shaft)	UJ369C
1994-1991 Explorer: [Type 1]			Drive Shaft (4 W/D)		
	U-Joint (Front)Ⓢ	UJ369	U-Joint		
	Brute Force Greaseable	UJ280	2021-2007 Expedition: [Type 17]		
	Brute Force Non Greaseable	UJ269		U-Joint (Rr. Shaft; Frt.)Ⓢ	UJ331
	(For Aluminum Drive Shaft)	UJ369C		Brute Force Greaseable	UJ232
	U-Joint (Rear)Ⓢ	UJ369		Brute Force Non Greaseable	UJ231
	Brute Force Greaseable	UJ280		(For Aluminum Drive Shaft)	UJ331C
	Brute Force Non Greaseable	UJ269		U-Joint (Rr. Shaft; Rr.)Ⓢ	UJ331
	(For Aluminum Drive Shaft)	UJ369C		Brute Force Greaseable	UJ232
1989-1986 Aerostar: [Type 1]				Brute Force Non Greaseable	UJ231
	U-Joint (Front)Ⓢ	UJ369		(For Aluminum Drive Shaft)	UJ331C
	Brute Force Greaseable	UJ280	2011-2000 Ranger: [Type 15]		
	Brute Force Non Greaseable	UJ269		U-Joint (Frt. Shaft; Frt.)Ⓢ	UJ369
	(For Aluminum Drive Shaft)	UJ369C		Brute Force Greaseable	UJ280
	U-Joint (Rear)Ⓢ	UJ430		Brute Force Non Greaseable	UJ269
	Brute Force Greaseable	UJ255		(For Aluminum Drive Shaft)	UJ369C
	U-Bolt Kit (Rear)	UJ534-10		Clamp Kit (Frt. Shaft; Frt.)	UJ437-10
1989-1986 Ranger w/ 3 Joint Shaft: [Type 2]				U-Joint (Rr. Shaft; Frt.)Ⓢ	UJ354
	U-Joint (Front)Ⓢ	UJ437G		Brute Force Greaseable	UJ270
	Brute Force Greaseable	UJ240		Brute Force Non Greaseable	UJ254
	Brute Force Non Greaseable	UJ237		(For Aluminum Drive Shaft)	UJ354C
	Clamp Kit (Front)	UJ437-10		U-Joint (Rr. Shaft; Rr.)Ⓢ	UJ354
	U-Joint (Center)Ⓢ	UJ437G		Brute Force Greaseable	UJ270
	Brute Force Greaseable	UJ240		Brute Force Non Greaseable	UJ254
	Brute Force Non Greaseable	UJ237		(For Aluminum Drive Shaft)	UJ354C
	Clamp Kit (Center)	UJ437-10	2010-2007 Explorer Sport Trac: [Type 23]		
	U-Joint (Rear)Ⓢ	UJ437G		U-Joint (Frt. Shaft; Frt.)Ⓢ	UJ369
	Brute Force Greaseable	UJ240		Brute Force Greaseable	UJ280
	Brute Force Non Greaseable	UJ237		Brute Force Non Greaseable	UJ269
	Clamp Kit (Rear)	UJ437-10		(For Aluminum Drive Shaft)	UJ369C
1989-1986 Ranger w/ 2 Joint Shaft: [Type 1]				Clamp Kit (Frt. Shaft; Frt.)	UJ437-10
	U-Joint (Front)Ⓢ	UJ369	(Continued)		
	Brute Force Greaseable	UJ280			
	Brute Force Non Greaseable	UJ269			
	(For Aluminum Drive Shaft)	UJ369C			
	U-Joint (Rear)Ⓢ	UJ369			
	Brute Force Greaseable	UJ280			
	Brute Force Non Greaseable	UJ269			
	(For Aluminum Drive Shaft)	UJ369C			

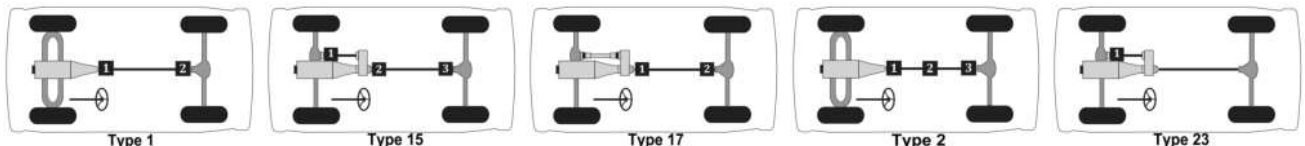

Passenger cars, light & medium trucks

Ford Truck Aerostar, Bronco II, Excursion, Expedition, Explorer (thru 2010), Explorer Sport Trac, Ranger -- (Cont.)

MFG./YEAR	MODEL & LOCATION	PART NO.	MFG./YEAR	MODEL & LOCATION	PART NO.
Drive Shaft (4 W/D) (Cont.)			Drive Shaft (4 W/D) (Cont.)		
U-Joint (Cont.)			U-Joint (Cont.)		
2010-2006 Explorer Exc. Sport Trac: [Type 15]			2005-2004 Excursion: [Type 30]		
	U-Joint (Fr. Shaft; Frt.)⊙	UJ369		U-Joint (Fr. Shaft; Frt.)⊙	UJ331
	Brute Force Greaseable	UJ280		Brute Force Greaseable	UJ232
	Brute Force Non Greaseable	UJ269		Brute Force Non Greaseable	UJ231
	(For Aluminum Drive Shaft)	UJ369C		(For Aluminum Drive Shaft)	UJ331C
	Clamp Kit (Fr. Shaft; Frt.)	UJ437-10		U-Joint (Fr. Shaft; Rr.)⊙	[2] UJ331
	U-Joint (Rr. Shaft; Frt.)⊙	UJ331		Brute Force Greaseable	UJ232
	Brute Force Greaseable	UJ232		Brute Force Non Greaseable	UJ231
	Brute Force Non Greaseable	UJ231		(For Aluminum Drive Shaft)	UJ331C
	(For Aluminum Drive Shaft)	UJ331C		U-Joint (Rr. Shaft; Frt.)⊙	UJ330
	U-Joint (Rr. Shaft; Rr.)⊙	UJ331		Brute Force Greaseable	UJ295
	Brute Force Greaseable	UJ232		(For Aluminum Drive Shaft)	UJ330C
	Brute Force Non Greaseable	UJ231		U-Joint (Rr. Shaft; Ctr.)⊙	UJ330
	(For Aluminum Drive Shaft)	UJ331C		Brute Force Greaseable	UJ295
	2006-2002 Expedition: [Type 13]			(For Aluminum Drive Shaft)	UJ330C
	U-Joint (Fr. Shaft; Frt.)⊙	UJ354		U-Joint (Wheel Joint)⊙	[2] UJ374
	Brute Force Greaseable	UJ270		Brute Force Non Greaseable	UJ374BF
	Brute Force Non Greaseable	UJ254		Centering Ball Kit	[1] UJ617
	(For Aluminum Drive Shaft)	UJ354C		Flange Yoke	UJ630F
	U-Joint (Fr. Shaft; Rr.)⊙	UJ354		H Yoke	UJ650
	Brute Force Greaseable	UJ270		2005-1997 Explorer & Explorer Sport Trac:	
	Brute Force Non Greaseable	UJ254		[Type 15]	
	(For Aluminum Drive Shaft)	UJ354C		U-Joint (Fr. Shaft; Frt.)⊙	UJ369
	U-Joint (Rr. Shaft; Frt.)⊙	UJ331		Brute Force Greaseable	UJ280
	Brute Force Greaseable	UJ232		Brute Force Non Greaseable	UJ269
	Brute Force Non Greaseable	UJ231		(For Aluminum Drive Shaft)	UJ369C
	(For Aluminum Drive Shaft)	UJ331C		Clamp Kit (Fr. Shaft; Frt.)	UJ437-10
	U-Joint (Rr. Shaft; Rr.)⊙	UJ331		U-Joint (Rr. Shaft; Frt.)⊙	UJ354
	Brute Force Greaseable	UJ232		Brute Force Greaseable	UJ270
	Brute Force Non Greaseable	UJ231		Brute Force Non Greaseable	UJ254
	(For Aluminum Drive Shaft)	UJ331C		(For Aluminum Drive Shaft)	UJ354C
	U-Joint (Rr. Shaft; Rr.)⊙	UJ331		U-Joint (Rr. Shaft; Rr.)⊙	UJ354
	Brute Force Greaseable	UJ232		Brute Force Greaseable	UJ270
	Brute Force Non Greaseable	UJ231		Brute Force Non Greaseable	UJ254
	(For Aluminum Drive Shaft)	UJ331C		(For Aluminum Drive Shaft)	UJ354C
					(Continued)

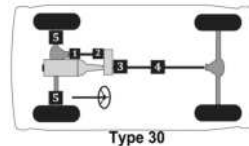
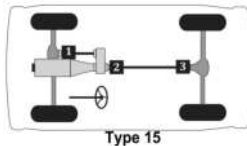
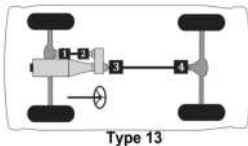

Passenger cars, light & medium trucks

(Cont.) -- Ford Truck Aerostar, Bronco II, Excursion, Expedition, Explorer (thru 2010), Explorer Sport Trac, Ranger

MFG./YEAR	MODEL & LOCATION	PART NO.	MFG./YEAR	MODEL & LOCATION	PART NO.
Drive Shaft (4 W/D) (Cont.)			Drive Shaft (4 W/D) (Cont.)		
U-Joint (Cont.)			U-Joint (Cont.)		
2003-2002 Excursion w/ 4.5" Yoke & 6.8L Eng.:			2003-2000 Excursion w/ 4" Yoke & 6.8L Eng.:		
[Type 26]			[Type 26]		
	U-Joint (Fr. Shaft; Frt.) ①	UJ331		U-Joint (Fr. Shaft; Frt.) ①	UJ331
	<i>Brute Force Greaseable</i>	UJ232		<i>Brute Force Greaseable</i>	UJ232
	<i>Brute Force Non Greaseable</i>	UJ231		<i>Brute Force Non Greaseable</i>	UJ231
	(For Aluminum Drive Shaft)	UJ331C		(For Aluminum Drive Shaft)	UJ331C
	U-Joint (Fr. Shaft; Rr.) ②	[2] UJ331		U-Joint (Fr. Shaft; Rr.) ②	[2] UJ331
	<i>Brute Force Greaseable</i>	UJ232		<i>Brute Force Greaseable</i>	UJ232
	<i>Brute Force Non Greaseable</i>	UJ231		<i>Brute Force Non Greaseable</i>	UJ231
	(For Aluminum Drive Shaft)	UJ331C		(For Aluminum Drive Shaft)	UJ331C
	U-Joint (Rr. Shaft; Frt.) ③	UJ330		U-Joint (Rr. Shaft; Frt.) ③	UJ331
	<i>Brute Force Greaseable</i>	UJ295		<i>Brute Force Greaseable</i>	UJ232
	(For Aluminum Drive Shaft)	UJ330C		<i>Brute Force Non Greaseable</i>	UJ231
	U-Joint (Rr. Shaft; Rr.) ④	UJ330		(For Aluminum Drive Shaft)	UJ331C
	<i>Brute Force Greaseable</i>	UJ295		U-Joint (Rr. Shaft; Rr.) ④	UJ331
	(For Aluminum Drive Shaft)	UJ330C		<i>Brute Force Greaseable</i>	UJ232
	U-Joint (Wheel Joint) ⑤	[2] UJ374		<i>Brute Force Non Greaseable</i>	UJ231
	<i>Brute Force Non Greaseable</i>	UJ374BF		(For Aluminum Drive Shaft)	UJ331C
	Ball Seat Repair Kit	UJ606		U-Joint (Wheel Joint) ⑤	[2] UJ374
	Centering Ball Kit	[1] UJ617		<i>Brute Force Non Greaseable</i>	UJ374BF
	H Yoke	UJ650		Centering Ball Kit	[1] UJ617
	2003-2000 Excursion w/ 5.4L Eng.:	[Type 26]		Flange Yoke	UJ630F
	U-Joint (Fr. Shaft; Frt.) ①	UJ331		H Yoke	UJ650
	<i>Brute Force Greaseable</i>	UJ232		2003-2000 Excursion w/ Diesel Eng.:	[Type 26]
	<i>Brute Force Non Greaseable</i>	UJ231		U-Joint (Fr. Shaft; Frt.) ①	UJ331
	(For Aluminum Drive Shaft)	UJ331C		<i>Brute Force Greaseable</i>	UJ232
	U-Joint (Fr. Shaft; Rr.) ②	[2] UJ331		<i>Brute Force Non Greaseable</i>	UJ231
	<i>Brute Force Greaseable</i>	UJ232		(For Aluminum Drive Shaft)	UJ331C
	<i>Brute Force Non Greaseable</i>	UJ231		U-Joint (Fr. Shaft; Rr.) ②	[2] UJ331
	(For Aluminum Drive Shaft)	UJ331C		<i>Brute Force Greaseable</i>	UJ232
	U-Joint (Rr. Shaft; Frt.) ③	UJ331		<i>Brute Force Non Greaseable</i>	UJ231
	<i>Brute Force Greaseable</i>	UJ232		(For Aluminum Drive Shaft)	UJ331C
	<i>Brute Force Non Greaseable</i>	UJ231		U-Joint (Rr. Shaft; Frt.) ③	UJ330
	(For Aluminum Drive Shaft)	UJ331C		<i>Brute Force Greaseable</i>	UJ295
	U-Joint (Rr. Shaft; Rr.) ④	UJ331		(For Aluminum Drive Shaft)	UJ330C
	<i>Brute Force Greaseable</i>	UJ232		U-Joint (Rr. Shaft; Rr.) ④	UJ330
	<i>Brute Force Non Greaseable</i>	UJ231		<i>Brute Force Greaseable</i>	UJ295
	(For Aluminum Drive Shaft)	UJ331C		(For Aluminum Drive Shaft)	UJ330C
	U-Joint (Wheel Joint) ⑤	[2] UJ374		U-Joint (Wheel Joint) ⑤	[2] UJ374
	<i>Brute Force Non Greaseable</i>	UJ374BF		<i>Brute Force Non Greaseable</i>	UJ374BF
	Centering Ball Kit	[1] UJ617		Centering Ball Kit	[1] UJ617
	Flange Yoke	UJ630F		Flange Yoke	UJ630F
	H Yoke	UJ650		H Yoke	UJ650

(Continued)

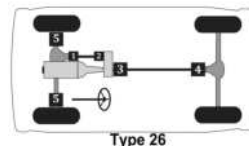

Passenger cars, light & medium trucks

Ford Truck Aerostar, Bronco II, Excursion, Expedition, Explorer (thru 2010), Explorer Sport Trac, Ranger -- (Cont.)

MFG./YEAR	MODEL & LOCATION	PART NO.	MFG./YEAR	MODEL & LOCATION	PART NO.
Drive Shaft (4 W/D) (Cont.)			Drive Shaft (4 W/D) (Cont.)		
U-Joint (Cont.)			U-Joint (Cont.)		
2001-2000 Excursion w/ 4.5" Yoke & 6.8L Eng.:			2001-1997 Expedition w/ 4.6L Eng. & Adjustable Suspension: [Type 13]		
[Type 26]					
U-Joint (Fr. Shaft; Frt.)⊙		UJ331	U-Joint (Fr. Shaft; Frt.)⊙		UJ354
Brute Force Greaseable		UJ232	Brute Force Greaseable		UJ270
Brute Force Non Greaseable		UJ231	Brute Force Non Greaseable		UJ254
(For Aluminum Drive Shaft)		UJ331C	(For Aluminum Drive Shaft)		UJ354C
U-Joint (Fr. Shaft; Rr.)⊙	[2]	UJ331	U-Joint (Fr. Shaft; Rr.)⊙		UJ354
Brute Force Greaseable		UJ232	Brute Force Greaseable		UJ270
Brute Force Non Greaseable		UJ231	Brute Force Non Greaseable		UJ254
(For Aluminum Drive Shaft)		UJ331C	(For Aluminum Drive Shaft)		UJ354C
U-Joint (Rr. Shaft; Frt.)⊙		UJ330	U-Joint (Rr. Shaft; Frt.)⊙		UJ331
Brute Force Greaseable		UJ295	Brute Force Greaseable		UJ232
(For Aluminum Drive Shaft)		UJ330C	Brute Force Non Greaseable		UJ231
U-Joint (Rr. Shaft; Rr.)⊙		UJ330	(For Aluminum Drive Shaft)		UJ331C
Brute Force Greaseable		UJ295	U-Joint (Rr. Shaft; Rr.)⊙		UJ331
(For Aluminum Drive Shaft)		UJ330C	Brute Force Greaseable		UJ232
U-Joint (Wheel Joint)⊙	[2]	UJ374	Brute Force Non Greaseable		UJ231
Brute Force Non Greaseable		UJ374BF	(For Aluminum Drive Shaft)		UJ331C
Centering Ball Kit	[1]	UJ617	2001-1997 Expedition w/ 5.4L Eng.: [Type 13]		
Flange Yoke		UJ630F	U-Joint (Fr. Shaft; Frt.)⊙		UJ354
H Yoke		UJ650	Brute Force Greaseable		UJ270
2001-1997 Expedition w/ 4.6L Eng. & Std. Suspension: [Type 13]			Brute Force Non Greaseable		UJ254
U-Joint (Fr. Shaft; Frt.)⊙		UJ354	(For Aluminum Drive Shaft)		UJ354C
Brute Force Greaseable		UJ270	U-Joint (Fr. Shaft; Rr.)⊙		UJ354
Brute Force Non Greaseable		UJ254	Brute Force Greaseable		UJ270
(For Aluminum Drive Shaft)		UJ354C	Brute Force Non Greaseable		UJ254
U-Joint (Fr. Shaft; Rr.)⊙		UJ354	(For Aluminum Drive Shaft)		UJ354C
Brute Force Greaseable		UJ270	U-Joint (Rr. Shaft; Frt.)⊙		UJ331
Brute Force Non Greaseable		UJ254	Brute Force Greaseable		UJ232
(For Aluminum Drive Shaft)		UJ354C	Brute Force Non Greaseable		UJ231
U-Joint (Rr. Shaft; Frt.)⊙		UJ354	(For Aluminum Drive Shaft)		UJ331C
Brute Force Greaseable		UJ270	U-Joint (Rr. Shaft; Rr.)⊙		UJ331
Brute Force Non Greaseable		UJ254	Brute Force Greaseable		UJ232
(For Aluminum Drive Shaft)		UJ354C	Brute Force Non Greaseable		UJ231
U-Joint (Rr. Shaft; Rr.)⊙		UJ354	(For Aluminum Drive Shaft)		UJ331C
Brute Force Greaseable		UJ270	1999-1998 Ranger w/ Reg. Cab & Short Bed:		
Brute Force Non Greaseable		UJ254	[Type 22]		
(For Aluminum Drive Shaft)		UJ354C	U-Joint (Fr. Shaft; Frt.)⊙		UJ369
			Brute Force Greaseable		UJ280
			Brute Force Non Greaseable		UJ269
			(For Aluminum Drive Shaft)		UJ369C
			Clamp Kit (Fr. Shaft; Frt.)		UJ437-10
			U-Joint (Rr. Shaft; Rr.)⊙		UJ354
			Brute Force Greaseable		UJ270
			Brute Force Non Greaseable		UJ254
			(For Aluminum Drive Shaft)		UJ354C

(Continued)

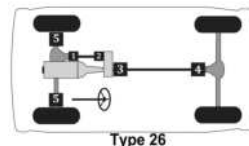
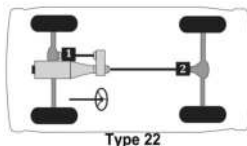
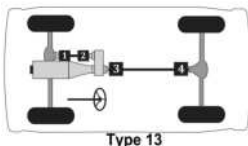

Passenger cars, light & medium trucks

(Cont.) -- Ford Truck Aerostar, Bronco II, Excursion, Expedition, Explorer (thru 2010), Explorer Sport Trac, Ranger

MFG./YEAR	MODEL & LOCATION	PART NO.	MFG./YEAR	MODEL & LOCATION	PART NO.
Drive Shaft (4 W/D) (Cont.)			Drive Shaft (4 W/D) (Cont.)		
U-Joint (Cont.)			U-Joint (Cont.)		
1999-1998 Ranger w/ Reg. Cab & Long Bed:			1997-1995 Ranger w/ 114" Wheel Base & 2 Joint		
[Type 15]			Front Shaft: [Type 36]		
U-Joint (Fr. Shaft; Frt.) ^①		UJ369	U-Joint (Fr. Shaft; Frt.) ^①		UJ369
Brute Force Greaseable		UJ280	Brute Force Greaseable		UJ280
Brute Force Non Greaseable		UJ269	Brute Force Non Greaseable		UJ269
(For Aluminum Drive Shaft)		UJ369C	(For Aluminum Drive Shaft)		UJ369C
Clamp Kit (Fr. Shaft; Frt.)		UJ437-10	Clamp Kit (Fr. Shaft; Frt.)		UJ437-10
U-Joint (Rr. Shaft; Rr.) ^②		UJ354	U-Joint (Fr. Shaft; Rr.) ^②		UJ369
Brute Force Greaseable		UJ270	Brute Force Greaseable		UJ280
Brute Force Non Greaseable		UJ254	Brute Force Non Greaseable		UJ269
(For Aluminum Drive Shaft)		UJ354C	(For Aluminum Drive Shaft)		UJ369C
U-Joint (Rr. Shaft; Rr.) ^③		UJ354	Clamp Kit (Fr. Shaft; Rr.)		UJ437-10
Brute Force Greaseable		UJ270	U-Joint (Rr. Shaft; Frt.) ^④		UJ354
Brute Force Non Greaseable		UJ254	Brute Force Greaseable		UJ270
(For Aluminum Drive Shaft)		UJ354C	Brute Force Non Greaseable		UJ254
1999-1998 Ranger w/ Ext. Cab: [Type 15]			(For Aluminum Drive Shaft)		UJ354C
U-Joint (Fr. Shaft; Frt.) ^①		UJ369	U-Joint (Rr. Shaft; Rr.) ^⑤		UJ354
Brute Force Greaseable		UJ280	Brute Force Greaseable		UJ270
Brute Force Non Greaseable		UJ269	Brute Force Non Greaseable		UJ254
(For Aluminum Drive Shaft)		UJ369C	(For Aluminum Drive Shaft)		UJ354C
Clamp Kit (Fr. Shaft; Frt.)		UJ437-10	U-Joint (Front Axle Left Outer) ^⑥		UJ371
U-Joint (Rr. Shaft; Frt.) ^②		UJ354	Brute Force Greaseable		UJ377
Brute Force Greaseable		UJ270	Brute Force Non Greaseable		UJ371
Brute Force Non Greaseable		UJ254	U-Joint (Front Axle Right Inner) ^⑥		UJ371
(For Aluminum Drive Shaft)		UJ354C	Brute Force Greaseable		UJ377
U-Joint (Rr. Shaft; Rr.) ^③		UJ354	Brute Force Non Greaseable		UJ371
Brute Force Greaseable		UJ270	U-Joint (Front Axle Right Outer) ^⑦		UJ371
Brute Force Non Greaseable		UJ254	Brute Force Greaseable		UJ377
(For Aluminum Drive Shaft)		UJ354C	Brute Force Non Greaseable		UJ371

(Continued)

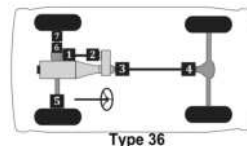
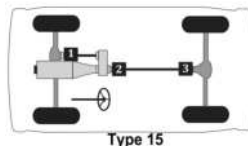

Passenger cars, light & medium trucks

Ford Truck Aerostar, Bronco II, Excursion, Expedition, Explorer (thru 2010), Explorer Sport Trac, Ranger -- (Cont.)

MFG./YEAR	MODEL & LOCATION	PART NO.	MFG./YEAR	MODEL & LOCATION	PART NO.
Drive Shaft (4 W/D) (Cont.)			Drive Shaft (4 W/D) (Cont.)		
U-Joint (Cont.)			U-Joint (Cont.)		
1997-1995 Ranger w/ 114" Wheel Base & 3 Joint			1997-1993 Ranger w/ 108" Wheel Base & 2 Joint		
Front Shaft: [Type 36]			Front Shaft: [Type 36]		
	U-Joint (Fr. Shaft; Fr.) [⊙]	UJ369		U-Joint (Fr. Shaft; Fr.) [⊙]	UJ369
	Brute Force Greaseable	UJ280		Brute Force Greaseable	UJ280
	Brute Force Non Greaseable	UJ269		Brute Force Non Greaseable	UJ269
	(For Aluminum Drive Shaft)	UJ369C		(For Aluminum Drive Shaft)	UJ369C
	Clamp Kit (Fr. Shaft; Fr.)	UJ437-10		Clamp Kit (Fr. Shaft; Fr.)	UJ437-10
	U-Joint (Fr. Shaft; Rr.) [⊙]	[2] UJ379		U-Joint (Fr. Shaft; Rr.) [⊙]	UJ369
	Brute Force Greaseable	UJ280		Brute Force Greaseable	UJ280
	Brute Force Non Greaseable	UJ269		Brute Force Non Greaseable	UJ269
	U-Joint (Rr. Shaft; Fr.) [⊙]	UJ354		(For Aluminum Drive Shaft)	UJ369C
	Brute Force Greaseable	UJ270		Clamp Kit (Fr. Shaft; Rr.)	UJ437-10
	Brute Force Non Greaseable	UJ254		U-Joint (Rr. Shaft; Fr.) [⊙]	[2] UJ379
	(For Aluminum Drive Shaft)	UJ354C		Brute Force Greaseable	UJ280
	U-Joint (Rr. Shaft; Rr.) [⊙]	UJ354		Brute Force Non Greaseable	UJ269
	Brute Force Greaseable	UJ270		U-Joint (Rr. Shaft; Rr.) [⊙]	UJ369
	Brute Force Non Greaseable	UJ254		Brute Force Greaseable	UJ280
	(For Aluminum Drive Shaft)	UJ354C		Brute Force Non Greaseable	UJ269
	U-Joint (Front Axle Left Outer) [⊙]	UJ371		(For Aluminum Drive Shaft)	UJ369C
	Brute Force Greaseable	UJ377		Clamp Kit (Rr. Shaft; Rr.)	UJ437-10
	Brute Force Non Greaseable	UJ371		U-Joint (Front Axle Left Outer) [⊙]	UJ371
	U-Joint (Front Axle Right Inner) [⊙]	UJ371		Brute Force Greaseable	UJ377
	Brute Force Greaseable	UJ377		Brute Force Non Greaseable	UJ371
	Brute Force Non Greaseable	UJ371		U-Joint (Front Axle Right Inner) [⊙]	UJ371
	U-Joint (Front Axle Right Outer) [⊙]	UJ371		Brute Force Greaseable	UJ377
	Brute Force Greaseable	UJ377		Brute Force Non Greaseable	UJ371
	Brute Force Non Greaseable	UJ371		U-Joint (Front Axle Right Outer) [⊙]	UJ371
	H Yoke	UJ647		Brute Force Greaseable	UJ377
				Brute Force Non Greaseable	UJ371

(Continued)

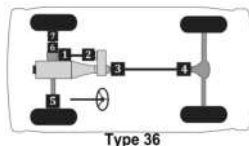

308 ▲ For Use w/ 1.063" Bearing Cap Application. ⊙ For Use w/ 1.188" Bearing Cap Application. ◇ For Use w/ Inner Lock Ring Application on Half Shaft. □ For Use w/ Outer Lock Ring Application on Half Shaft.

Passenger cars, light & medium trucks

(Cont.) -- Ford Truck Aerostar, Bronco II, Excursion, Expedition, Explorer (thru 2010), Explorer Sport Trac, Ranger

MFG./YEAR	MODEL & LOCATION	PART NO.	MFG./YEAR	MODEL & LOCATION	PART NO.
Drive Shaft (4 W/D) (Cont.)			Drive Shaft (4 W/D) (Cont.)		
U-Joint (Cont.)			U-Joint (Cont.)		
1997-1993 Ranger w/ 108" Wheel Base & 3 Joint			1997-1993 Ranger w/ 125" Wheel Base & 2 Joint		
Front Shaft: [Type 36]			Front Shaft: [Type 37]		
	U-Joint (Fr. Shaft; Fr.) ^①	UJ369		U-Joint (Fr. Shaft; Fr.) ^①	UJ369
	Brute Force Greaseable	UJ280		Brute Force Greaseable	UJ280
	Brute Force Non Greaseable	UJ269		Brute Force Non Greaseable	UJ269
	(For Aluminum Drive Shaft)	UJ369C		(For Aluminum Drive Shaft)	UJ369C
	Clamp Kit (Fr. Shaft; Fr.)	UJ437-10		Clamp Kit (Fr. Shaft; Fr.)	UJ437-10
	U-Joint (Fr. Shaft; Rr.) ^②	[2] UJ379		U-Joint (Fr. Shaft; Rr.) ^②	UJ369
	Brute Force Greaseable	UJ280		Brute Force Greaseable	UJ280
	Brute Force Non Greaseable	UJ269		Brute Force Non Greaseable	UJ269
	U-Joint (Rr. Shaft; Fr.) ^③	[2] UJ379		(For Aluminum Drive Shaft)	UJ369C
	Brute Force Greaseable	UJ280		Clamp Kit (Fr. Shaft; Rr.)	UJ437-10
	Brute Force Non Greaseable	UJ269		U-Joint (Rr. Shaft; Fr.) ^④	UJ369
	U-Joint (Rr. Shaft; Rr.) ^④	UJ369		Brute Force Greaseable	UJ280
	Brute Force Greaseable	UJ280		Brute Force Non Greaseable	UJ269
	Brute Force Non Greaseable	UJ269		(For Aluminum Drive Shaft)	UJ369C
	(For Aluminum Drive Shaft)	UJ369C		Clamp Kit (Rr. Shaft; Fr.)	UJ437-10
	Clamp Kit (Rr. Shaft; Rr.)	UJ437-10		U-Joint (Rr. Shaft; Ctr.) ^⑤	UJ369
	U-Joint (Front Axle Left Outer) ^⑥	UJ371		Brute Force Greaseable	UJ280
	Brute Force Greaseable	UJ377		Brute Force Non Greaseable	UJ269
	Brute Force Non Greaseable	UJ371		(For Aluminum Drive Shaft)	UJ369C
	U-Joint (Front Axle Right Inner) ^⑥	UJ371		Clamp Kit (Rr. Shaft; Ctr.)	UJ437-10
	Brute Force Greaseable	UJ377		U-Joint (Rr. Shaft; Rr.) ^⑥	UJ369
	Brute Force Non Greaseable	UJ371		Brute Force Greaseable	UJ280
	U-Joint (Front Axle Right Outer) ^⑦	UJ371		Brute Force Non Greaseable	UJ269
	Brute Force Greaseable	UJ377		(For Aluminum Drive Shaft)	UJ369C
	Brute Force Non Greaseable	UJ371		Clamp Kit (Rr. Shaft; Rr.)	UJ437-10
	H Yoke	UJ647		U-Joint (Front Axle Left Outer) ^⑧	UJ371
				Brute Force Greaseable	UJ377
				Brute Force Non Greaseable	UJ371
				U-Joint (Front Axle Right Inner) ^⑦	UJ371
				Brute Force Greaseable	UJ377
				Brute Force Non Greaseable	UJ371
				U-Joint (Front Axle Right Outer) ^⑧	UJ371
				Brute Force Greaseable	UJ377
				Brute Force Non Greaseable	UJ371

(Continued)

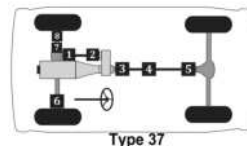
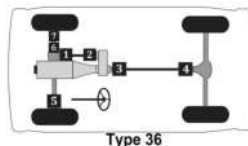

Passenger cars, light & medium trucks

Ford Truck Aerostar, Bronco II, Excursion, Expedition, Explorer (thru 2010), Explorer Sport Trac, Ranger -- (Cont.)

MFG./YEAR	MODEL & LOCATION	PART NO.	MFG./YEAR	MODEL & LOCATION	PART NO.
Drive Shaft (4 W/D) (Cont.)			Drive Shaft (4 W/D) (Cont.)		
U-Joint (Cont.)			U-Joint (Cont.)		
1997-1993 Ranger w/ 125" Wheel Base & 3 Joint			1997-1990 Aerostar: [Type 40]		
Front Shaft: [Type 37]					
	U-Joint (Fr. Shaft; Frt.) ^①	UJ369		U-Joint (Fr. Shaft; Frt.) ^①	UJ437G
	Brute Force Greaseable	UJ280		Brute Force Greaseable	UJ240
	Brute Force Non Greaseable	UJ269		Brute Force Non Greaseable	UJ237
	(For Aluminum Drive Shaft)	UJ369C		Clamp Kit (Fr. Shaft; Frt.)	UJ437-10
	Clamp Kit (Fr. Shaft; Frt.)	UJ437-10		U-Joint (Fr. Shaft; Rr.)^②	UJ437G
	U-Joint (Fr. Shaft; Rr.)^②	[2] UJ379		Brute Force Greaseable	UJ240
	Brute Force Greaseable	UJ280		Brute Force Non Greaseable	UJ237
	Brute Force Non Greaseable	UJ269		Clamp Kit (Fr. Shaft; Rr.)	UJ437-10
	U-Joint (Rr. Shaft; Frt.)^③	UJ369		U-Joint (Rr. Shaft; Frt.)^③	UJ369
	Brute Force Greaseable	UJ280		Brute Force Greaseable	UJ280
	Brute Force Non Greaseable	UJ269		Brute Force Non Greaseable	UJ269
	(For Aluminum Drive Shaft)	UJ369C		(For Aluminum Drive Shaft)	UJ369C
	Clamp Kit (Rr. Shaft; Frt.)	UJ437-10		U-Joint (Rr. Shaft; Rr.)^④	UJ369
	U-Joint (Rr. Shaft; Ctr.)^④	UJ369		Brute Force Greaseable	UJ280
	Brute Force Greaseable	UJ280		Brute Force Non Greaseable	UJ269
	Brute Force Non Greaseable	UJ269		(For Aluminum Drive Shaft)	UJ369C
	(For Aluminum Drive Shaft)	UJ369C		U-Joint (Front Axle Left Inner)^⑤	[1] UJ237
	Clamp Kit (Rr. Shaft; Ctr.)	UJ437-10		U-Joint (Front Axle Right Inner)^⑤	UJ237
	U-Joint (Rr. Shaft; Rr.)^⑤	UJ369		1996-1995 Explorer w/ 2 Doors & 2 Joint Front Shaft: [Type 13]	
	Brute Force Greaseable	UJ280		U-Joint (Fr. Shaft; Frt.) ^①	UJ369
	Brute Force Non Greaseable	UJ269		Brute Force Greaseable	UJ280
	(For Aluminum Drive Shaft)	UJ369C		Brute Force Non Greaseable	UJ269
	Clamp Kit (Rr. Shaft; Rr.)	UJ437-10		(For Aluminum Drive Shaft)	UJ369C
	U-Joint (Front Axle Left Outer)^⑥	UJ371		Clamp Kit (Fr. Shaft; Frt.)	UJ437-10
	Brute Force Greaseable	UJ377		U-Joint (Fr. Shaft; Rr.)^②	UJ369
	Brute Force Non Greaseable	UJ371		Brute Force Greaseable	UJ280
	U-Joint (Front Axle Right Inner)^⑦	UJ371		Brute Force Non Greaseable	UJ269
	Brute Force Greaseable	UJ377		(For Aluminum Drive Shaft)	UJ369C
	Brute Force Non Greaseable	UJ371		Clamp Kit (Fr. Shaft; Rr.)	UJ437-10
	U-Joint (Front Axle Right Outer)^⑧	UJ371		U-Joint (Rr. Shaft; Frt.)^⑨	[2] UJ379
	Brute Force Greaseable	UJ377		Brute Force Greaseable	UJ280
	Brute Force Non Greaseable	UJ371		Brute Force Non Greaseable	UJ269
	H Yoke	UJ647		U-Joint (Rr. Shaft; Rr.)^⑩	UJ354
				Brute Force Greaseable	UJ270
				Brute Force Non Greaseable	UJ254
				(For Aluminum Drive Shaft)	UJ354C

(Continued)

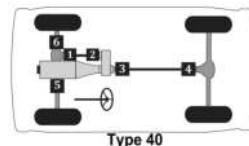
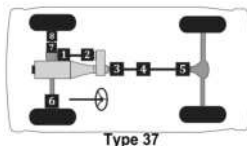
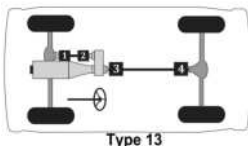

310 ▲ For Use w/ 1.063" Bearing Cap Application. ⊙ For Use w/ 1.188" Bearing Cap Application. ◇ For Use w/ Inner Lock Ring Application on Half Shaft. □ For Use w/ Outer Lock Ring Application on Half Shaft.

Passenger cars, light & medium trucks

(Cont.) -- Ford Truck Aerostar, Bronco II, Excursion, Expedition, Explorer (thru 2010), Explorer Sport Trac, Ranger

MFG./YEAR	MODEL & LOCATION	PART NO.	MFG./YEAR	MODEL & LOCATION	PART NO.
Drive Shaft (4 W/D) (Cont.)			Drive Shaft (4 W/D) (Cont.)		
U-Joint (Cont.)			U-Joint (Cont.)		
1996-1995 Explorer w/ 2 Doors & 3 Joint Front			1996-1995 Explorer w/ 4 Doors & 3 Joint Front		
Shaft: [Type 13]			Shaft: [Type 13]		
	U-Joint (Fr. Shaft; Fr.) ^①	UJ369		U-Joint (Fr. Shaft; Fr.) ^①	UJ369
	Brute Force Greaseable	UJ280		Brute Force Greaseable	UJ280
	Brute Force Non Greaseable	UJ269		Brute Force Non Greaseable	UJ269
	(For Aluminum Drive Shaft)	UJ369C		(For Aluminum Drive Shaft)	UJ369C
	Clamp Kit (Fr. Shaft; Fr.)	UJ437-10		Clamp Kit (Fr. Shaft; Fr.)	UJ437-10
	U-Joint (Fr. Shaft; Rr.) ^②	[2] UJ379		U-Joint (Fr. Shaft; Rr.) ^②	[2] UJ379
	Brute Force Greaseable	UJ280		Brute Force Greaseable	UJ280
	Brute Force Non Greaseable	UJ269		Brute Force Non Greaseable	UJ269
	U-Joint (Rr. Shaft; Fr.) ^③	[2] UJ379		U-Joint (Rr. Shaft; Fr.) ^③	UJ354
	Brute Force Greaseable	UJ280		Brute Force Greaseable	UJ270
	Brute Force Non Greaseable	UJ269		Brute Force Non Greaseable	UJ254
	U-Joint (Rr. Shaft; Rr.) ^④	UJ354		U-Joint (Rr. Shaft; Rr.) ^④	UJ354C
	Brute Force Greaseable	UJ270		Brute Force Greaseable	UJ270
	Brute Force Non Greaseable	UJ254		Brute Force Non Greaseable	UJ254
	(For Aluminum Drive Shaft)	UJ354C		(For Aluminum Drive Shaft)	UJ354C
	H Yoke	UJ647		H Yoke	UJ647
1996-1995 Explorer w/ 4 Doors & 2 Joint Front			1994-1993 Ranger w/ 114" Wheel Base & 2 Joint		
Shaft: [Type 13]			Front Shaft: [Type 36]		
	U-Joint (Fr. Shaft; Fr.) ^①	UJ369		U-Joint (Fr. Shaft; Fr.) ^①	UJ369
	Brute Force Greaseable	UJ280		Brute Force Greaseable	UJ280
	Brute Force Non Greaseable	UJ269		Brute Force Non Greaseable	UJ269
	(For Aluminum Drive Shaft)	UJ369C		(For Aluminum Drive Shaft)	UJ369C
	Clamp Kit (Fr. Shaft; Fr.)	UJ437-10		U-Joint (Fr. Shaft; Rr.) ^②	UJ369
	U-Joint (Fr. Shaft; Rr.) ^②	UJ369		Brute Force Greaseable	UJ280
	Brute Force Greaseable	UJ280		Brute Force Non Greaseable	UJ269
	Brute Force Non Greaseable	UJ269		(For Aluminum Drive Shaft)	UJ369C
	(For Aluminum Drive Shaft)	UJ369C		U-Joint (Rr. Shaft; Fr.) ^③	UJ369
	Clamp Kit (Fr. Shaft; Rr.)	UJ437-10		Brute Force Greaseable	UJ280
	U-Joint (Rr. Shaft; Fr.) ^③	UJ354		Brute Force Non Greaseable	UJ269
	Brute Force Greaseable	UJ270		(For Aluminum Drive Shaft)	UJ369C
	Brute Force Non Greaseable	UJ254		U-Joint (Rr. Shaft; Rr.) ^④	UJ369
	(For Aluminum Drive Shaft)	UJ354C		Brute Force Greaseable	UJ280
	U-Joint (Rr. Shaft; Rr.) ^④	UJ354		Brute Force Non Greaseable	UJ269
	Brute Force Greaseable	UJ270		(For Aluminum Drive Shaft)	UJ369C
	Brute Force Non Greaseable	UJ254		U-Joint (Front Axle Left Outer) ^⑤	UJ371
	(For Aluminum Drive Shaft)	UJ354C		Brute Force Greaseable	UJ377
				Brute Force Non Greaseable	UJ371
				U-Joint (Front Axle Right Inner) ^⑥	UJ371
				Brute Force Greaseable	UJ377
				Brute Force Non Greaseable	UJ371
				U-Joint (Front Axle Right Outer) ^⑦	UJ371
				Brute Force Greaseable	UJ377
				Brute Force Non Greaseable	UJ371

(Continued)

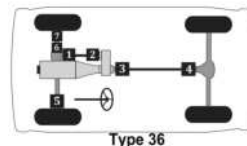
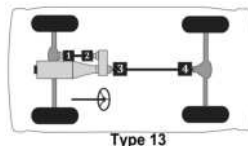

Passenger cars, light & medium trucks

Ford Truck Aerostar, Bronco II, Excursion, Expedition, Explorer (thru 2010), Explorer Sport Trac, Ranger -- (Cont.)

MFG./YEAR	MODEL & LOCATION	PART NO.	MFG./YEAR	MODEL & LOCATION	PART NO.
Drive Shaft (4 W/D) (Cont.)			Drive Shaft (4 W/D) (Cont.)		
U-Joint (Cont.)			U-Joint (Cont.)		
1994-1993 Ranger w/ 114" Wheel Base & 3 Joint			1994-1993 Explorer w/ 1.063" Dia. Brg. Cap Axle		
Front Shaft: [Type 36]			Joints Exc. 4 Doors w/ Man. Trans.:		
[Type 26]			[Type 26]		
U-Joint (Fr. Shaft; Frt.) [⊙]		UJ369	U-Joint (Fr. Shaft; Frt.) [⊙]		UJ369
Brute Force Greaseable		UJ280	Brute Force Greaseable		UJ280
Brute Force Non Greaseable		UJ269	Brute Force Non Greaseable		UJ269
(For Aluminum Drive Shaft)		UJ369C	(For Aluminum Drive Shaft)		UJ369C
U-Joint (Fr. Shaft; Rr.) [⊙]	[2]	UJ379	U-Joint (Fr. Shaft; Rr.) [⊙]	[2]	UJ379
Brute Force Greaseable		UJ280	Brute Force Greaseable		UJ280
Brute Force Non Greaseable		UJ269	Brute Force Non Greaseable		UJ269
U-Joint (Rr. Shaft; Frt.) [⊙]		UJ369	U-Joint (Rr. Shaft; Frt.) [⊙]		UJ369
Brute Force Greaseable		UJ280	Brute Force Greaseable		UJ280
Brute Force Non Greaseable		UJ269	Brute Force Non Greaseable		UJ269
(For Aluminum Drive Shaft)		UJ369C	(For Aluminum Drive Shaft)		UJ369C
U-Joint (Rr. Shaft; Rr.) [⊙]		UJ369	U-Joint (Rr. Shaft; Rr.) [⊙]		UJ369
Brute Force Greaseable		UJ280	Brute Force Greaseable		UJ280
Brute Force Non Greaseable		UJ269	Brute Force Non Greaseable		UJ269
(For Aluminum Drive Shaft)		UJ369C	(For Aluminum Drive Shaft)		UJ369C
U-Joint (Front Axle Left Outer) [⊙]		UJ371	U-Joint (Front Axle Left Outer) [⊙]		UJ371
Brute Force Greaseable		UJ377	Brute Force Greaseable		UJ377
Brute Force Non Greaseable		UJ371	Brute Force Non Greaseable		UJ371
U-Joint (Front Axle Right Inner) [⊙]		UJ371	U-Joint (Front Axle Right Inner) [⊙]		UJ371
Brute Force Greaseable		UJ377	Brute Force Greaseable		UJ377
Brute Force Non Greaseable		UJ371	Brute Force Non Greaseable		UJ371
U-Joint (Front Axle Right Outer) [⊙]		UJ371	U-Joint (Front Axle Right Outer) [⊙]		UJ371
Brute Force Greaseable		UJ377	Brute Force Greaseable		UJ377
Brute Force Non Greaseable		UJ371	Brute Force Non Greaseable		UJ371
H Yoke		UJ647	H Yoke		UJ647
					(Continued)

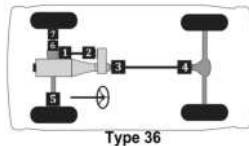
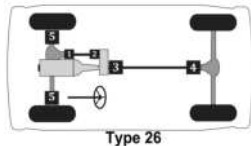

312 ▲ For Use w/ 1.063" Bearing Cap Application. ⊙ For Use w/ 1.188" Bearing Cap Application. ◇ For Use w/ Inner Lock Ring Application on Half Shaft. □ For Use w/ Outer Lock Ring Application on Half Shaft.

Passenger cars, light & medium trucks

(Cont.) -- Ford Truck Aerostar, Bronco II, Excursion, Expedition, Explorer (thru 2010), Explorer Sport Trac, Ranger

MFG./YEAR	MODEL & LOCATION	PART NO.	MFG./YEAR	MODEL & LOCATION	PART NO.
Drive Shaft (4 W/D) (Cont.)			Drive Shaft (4 W/D) (Cont.)		
U-Joint (Cont.)			U-Joint (Cont.)		
1994-1993 Explorer w/ 1.188" Dia. Brg. Cap Axle			1994-1993 Explorer w/ 4 Doors, Man. Trans. &		
Joints Exc. 4 Doors w/ Man. Trans.:			1.188" Dia. Brg. Cap Axle Joints:		
[Type 26]			[Type 26]		
U-Joint (Frt. Shaft; Frt.) ①		UJ369	U-Joint (Frt. Shaft; Frt.) ①		UJ369
Brute Force Greaseable		UJ280	Brute Force Greaseable		UJ280
Brute Force Non Greaseable		UJ269	Brute Force Non Greaseable		UJ269
(For Aluminum Drive Shaft)		UJ369C	(For Aluminum Drive Shaft)		UJ369C
Clamp Kit (Frt. Shaft; Frt.)		UJ437-10	Clamp Kit (Frt. Shaft; Frt.)		UJ437-10
U-Joint (Frt. Shaft; Rr.) ②	[2]	UJ379	U-Joint (Frt. Shaft; Rr.) ②	[2]	UJ379
Brute Force Greaseable		UJ280	Brute Force Greaseable		UJ280
Brute Force Non Greaseable		UJ269	Brute Force Non Greaseable		UJ269
U-Joint (Rr. Shaft; Frt.) ③		UJ369	U-Joint (Rr. Shaft; Frt.) ③		UJ354
Brute Force Greaseable		UJ280	Brute Force Greaseable		UJ270
Brute Force Non Greaseable		UJ269	Brute Force Non Greaseable		UJ254
(For Aluminum Drive Shaft)		UJ369C	(For Aluminum Drive Shaft)		UJ354C
Clamp Kit (Rr. Shaft; Frt.)		UJ437-10	U-Joint (Rr. Shaft; Rr.) ④		UJ354
U-Joint (Rr. Shaft; Rr.) ④		UJ369	Brute Force Greaseable		UJ270
Brute Force Greaseable		UJ280	Brute Force Non Greaseable		UJ254
Brute Force Non Greaseable		UJ269	(For Aluminum Drive Shaft)		UJ354C
(For Aluminum Drive Shaft)		UJ369C	U-Joint (Wheel Joint) ⑤	[2]	UJ371
Clamp Kit (Rr. Shaft; Rr.)		UJ437-10	Brute Force Greaseable		UJ377
U-Joint (Wheel Joint) ⑤	[2]	UJ371	Brute Force Non Greaseable		UJ371
Brute Force Greaseable		UJ377	H Yoke		UJ647
Brute Force Non Greaseable		UJ371	1992-1991 Explorer w/ 1.063" Dia. Brg. Cap Axle		
H Yoke		UJ647	Joints Exc. 4 Doors w/ Man. Trans.:		
1994-1993 Explorer w/ 4 Doors, Man. Trans. &			[Type 26]		
1.063" Dia. Brg. Cap Axle Joints:			U-Joint (Frt. Shaft; Frt.) ①		UJ369
[Type 26]			Brute Force Greaseable		UJ280
U-Joint (Frt. Shaft; Frt.) ①		UJ369	Brute Force Non Greaseable		UJ269
Brute Force Greaseable		UJ280	(For Aluminum Drive Shaft)		UJ369C
Brute Force Non Greaseable		UJ269	Clamp Kit (Frt. Shaft; Frt.)		UJ437-10
(For Aluminum Drive Shaft)		UJ369C	U-Joint (Frt. Shaft; Rr.) ②	[2]	UJ379
Clamp Kit (Frt. Shaft; Frt.)		UJ437-10	Brute Force Greaseable		UJ280
U-Joint (Frt. Shaft; Rr.) ②	[2]	UJ379	Brute Force Non Greaseable		UJ269
Brute Force Greaseable		UJ280	U-Joint (Rr. Shaft; Frt.) ③		UJ369
Brute Force Non Greaseable		UJ269	Brute Force Greaseable		UJ280
U-Joint (Rr. Shaft; Frt.) ③		UJ354	Brute Force Non Greaseable		UJ269
Brute Force Greaseable		UJ270	(For Aluminum Drive Shaft)		UJ369C
Brute Force Non Greaseable		UJ254	Clamp Kit (Rr. Shaft; Frt.)		UJ437-10
(For Aluminum Drive Shaft)		UJ354C	U-Joint (Rr. Shaft; Rr.) ④		UJ369
U-Joint (Rr. Shaft; Rr.) ④		UJ354	Brute Force Greaseable		UJ280
Brute Force Greaseable		UJ270	Brute Force Non Greaseable		UJ269
Brute Force Non Greaseable		UJ254	(For Aluminum Drive Shaft)		UJ369C
(For Aluminum Drive Shaft)		UJ354C	Clamp Kit (Rr. Shaft; Rr.)		UJ437-10
U-Joint (Wheel Joint) ⑤	[2]	UJ436	U-Joint (Wheel Joint) ⑤	[2]	UJ436
Brute Force Greaseable		UJ466	Brute Force Greaseable		UJ466
Brute Force Non Greaseable		UJ436	Brute Force Non Greaseable		UJ436
H Yoke		UJ647	Centering Yoke		UJ607
			H Yoke		UJ647

(Continued)

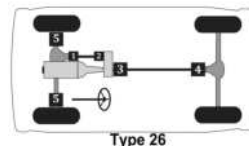

Passenger cars, light & medium trucks

Ford Truck Aerostar, Bronco II, Excursion, Expedition, Explorer (thru 2010), Explorer Sport Trac, Ranger -- (Cont.)

MFG./YEAR	MODEL & LOCATION	PART NO.	MFG./YEAR	MODEL & LOCATION	PART NO.
Drive Shaft (4 W/D) (Cont.)			Drive Shaft (4 W/D) (Cont.)		
U-Joint (Cont.)			U-Joint (Cont.)		
1992-1991 Explorer w/ 1.188" Dia. Brg. Cap Axle			1992-1991 Explorer w/ 4 Doors, Man. Trans. & 1.188" Dia. Brg. Cap Axle Joints:		
Joints Exc. 4 Doors w/ Man. Trans.:			[Type 26]		
[Type 26]			[Type 26]		
U-Joint (Fr. Shaft; Frt.) [⊙]		UJ369	U-Joint (Fr. Shaft; Frt.) [⊙]		UJ369
Brute Force Greaseable		UJ280	Brute Force Greaseable		UJ280
Brute Force Non Greaseable		UJ269	Brute Force Non Greaseable		UJ269
(For Aluminum Drive Shaft)		UJ369C	(For Aluminum Drive Shaft)		UJ369C
Clamp Kit (Fr. Shaft; Frt.)		UJ437-10	Clamp Kit (Fr. Shaft; Frt.)		UJ437-10
U-Joint (Fr. Shaft; Rr.) [⊙]	[2]	UJ379	U-Joint (Fr. Shaft; Rr.) [⊙]	[2]	UJ379
Brute Force Greaseable		UJ280	Brute Force Greaseable		UJ280
Brute Force Non Greaseable		UJ269	Brute Force Non Greaseable		UJ269
U-Joint (Rr. Shaft; Frt.) [⊙]		UJ369	U-Joint (Rr. Shaft; Frt.) [⊙]		UJ354
Brute Force Greaseable		UJ280	Brute Force Greaseable		UJ270
Brute Force Non Greaseable		UJ269	Brute Force Non Greaseable		UJ254
(For Aluminum Drive Shaft)		UJ369C	(For Aluminum Drive Shaft)		UJ354C
Clamp Kit (Rr. Shaft; Frt.)		UJ437-10	U-Joint (Rr. Shaft; Rr.) [⊙]		UJ354
U-Joint (Rr. Shaft; Rr.) [⊙]		UJ369	Brute Force Greaseable		UJ270
Brute Force Greaseable		UJ280	Brute Force Non Greaseable		UJ254
Brute Force Non Greaseable		UJ269	(For Aluminum Drive Shaft)		UJ354C
(For Aluminum Drive Shaft)		UJ369C	U-Joint (Wheel Joint) [⊙]	[2]	UJ371
Clamp Kit (Rr. Shaft; Rr.)		UJ437-10	Brute Force Greaseable		UJ377
U-Joint (Wheel Joint) [⊙]	[2]	UJ371	Brute Force Non Greaseable		UJ371
Brute Force Greaseable		UJ377	Centering Yoke		UJ607
Brute Force Non Greaseable		UJ371	H Yoke		UJ647
Centering Yoke		UJ607			(Continued)
H Yoke		UJ647			
1992-1991 Explorer w/ 4 Doors, Man. Trans. & 1.063" Dia. Brg. Cap Axle Joints:					
[Type 26]					
U-Joint (Fr. Shaft; Frt.) [⊙]		UJ369			
Brute Force Greaseable		UJ280			
Brute Force Non Greaseable		UJ269			
(For Aluminum Drive Shaft)		UJ369C			
Clamp Kit (Fr. Shaft; Frt.)		UJ437-10			
U-Joint (Fr. Shaft; Rr.) [⊙]	[2]	UJ379			
Brute Force Greaseable		UJ280			
Brute Force Non Greaseable		UJ269			
U-Joint (Rr. Shaft; Frt.) [⊙]		UJ354			
Brute Force Greaseable		UJ270			
Brute Force Non Greaseable		UJ254			
(For Aluminum Drive Shaft)		UJ354C			
U-Joint (Rr. Shaft; Rr.) [⊙]		UJ354			
Brute Force Greaseable		UJ270			
Brute Force Non Greaseable		UJ254			
(For Aluminum Drive Shaft)		UJ354C			
U-Joint (Wheel Joint) [⊙]	[2]	UJ436			
Brute Force Greaseable		UJ466			
Brute Force Non Greaseable		UJ436			
Centering Yoke		UJ607			
H Yoke		UJ647			

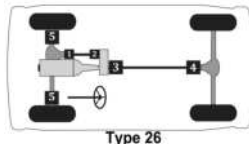

314 ▲ For Use w/ 1.063" Bearing Cap Application. ⊙ For Use w/ 1.188" Bearing Cap Application. ◇ For Use w/ Inner Lock Ring Application on Half Shaft. □ For Use w/ Outer Lock Ring Application on Half Shaft.

Passenger cars, light & medium trucks

(Cont.) -- Ford Truck Aerostar, Bronco II, Excursion, Expedition, Explorer (thru 2010), Explorer Sport Trac, Ranger

MFG./YEAR	MODEL & LOCATION	PART NO.	MFG./YEAR	MODEL & LOCATION	PART NO.
Drive Shaft (4 W/D) (Cont.)			Drive Shaft (4 W/D) (Cont.)		
U-Joint (Cont.)			U-Joint (Cont.)		
1992-1990 Ranger w/ 108" Wheel Base & 1.063"			1992-1990 Ranger w/ 108" Wheel Base & 1.188"		
Dia. Brg. Cap Axle Joints: [Type 36]			Dia. Brg. Cap Axle Joints: [Type 36]		
U-Joint (Fr. Shaft; Fr.) ^①		UJ369	U-Joint (Fr. Shaft; Fr.) ^①		UJ369
Brute Force Greaseable		UJ280	Brute Force Greaseable		UJ280
Brute Force Non Greaseable		UJ269	Brute Force Non Greaseable		UJ269
(For Aluminum Drive Shaft)		UJ369C	(For Aluminum Drive Shaft)		UJ369C
Clamp Kit (Fr. Shaft; Fr.)		UJ437-10	Clamp Kit (Fr. Shaft; Fr.)		UJ437-10
U-Joint (Fr. Shaft; Rr.) ^②	[2]	UJ379	U-Joint (Fr. Shaft; Rr.) ^②	[2]	UJ379
Brute Force Greaseable		UJ280	Brute Force Greaseable		UJ280
Brute Force Non Greaseable		UJ269	Brute Force Non Greaseable		UJ269
U-Joint (Rr. Shaft; Fr.) ^③	[2]	UJ379	U-Joint (Rr. Shaft; Fr.) ^③	[2]	UJ379
Brute Force Greaseable		UJ280	Brute Force Greaseable		UJ280
Brute Force Non Greaseable		UJ269	Brute Force Non Greaseable		UJ269
U-Joint (Rr. Shaft; Rr.) ^④		UJ369	U-Joint (Rr. Shaft; Rr.) ^④		UJ369
Brute Force Greaseable		UJ280	Brute Force Greaseable		UJ280
Brute Force Non Greaseable		UJ269	Brute Force Non Greaseable		UJ269
(For Aluminum Drive Shaft)		UJ369C	(For Aluminum Drive Shaft)		UJ369C
Clamp Kit (Rr. Shaft; Rr.)		UJ437-10	Clamp Kit (Rr. Shaft; Rr.)		UJ437-10
U-Joint (Front Axle Left Outer) ^⑤		UJ436	U-Joint (Front Axle Left Outer) ^⑤		UJ371
Brute Force Greaseable		UJ466	Brute Force Greaseable		UJ377
Brute Force Non Greaseable		UJ436	Brute Force Non Greaseable		UJ371
U-Joint (Front Axle Right Inner) ^⑥		UJ436	U-Joint (Front Axle Right Inner) ^⑥		UJ371
Brute Force Greaseable		UJ466	Brute Force Greaseable		UJ377
Brute Force Non Greaseable		UJ436	Brute Force Non Greaseable		UJ371
U-Joint (Front Axle Right Outer) ^⑦		UJ436	U-Joint (Front Axle Right Outer) ^⑦		UJ371
Brute Force Greaseable		UJ466	Brute Force Greaseable		UJ377
Brute Force Non Greaseable		UJ436	Brute Force Non Greaseable		UJ371
H Yoke		UJ647	H Yoke		UJ647

(Continued)

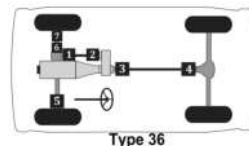

Passenger cars, light & medium trucks

Ford Truck Aerostar, Bronco II, Excursion, Expedition, Explorer (thru 2010), Explorer Sport Trac, Ranger -- (Cont.)

MFG./YEAR	MODEL & LOCATION	PART NO.	MFG./YEAR	MODEL & LOCATION	PART NO.
Drive Shaft (4 W/D) (Cont.)			Drive Shaft (4 W/D) (Cont.)		
U-Joint (Cont.)			U-Joint (Cont.)		
1992-1990 Ranger w/ 114" Wheel Base & 1.063" Dia. Brg. Cap Axle Joints: [Type 36]			1992-1990 Ranger w/ 114" Wheel Base & 1.188" Dia. Brg. Cap Axle Joints: [Type 36]		
U-Joint (Fr. Shaft; Frt.) [⊙]		UJ369	U-Joint (Fr. Shaft; Frt.) [⊙]		UJ369
Brute Force Greaseable		UJ280	Brute Force Greaseable		UJ280
Brute Force Non Greaseable		UJ269	Brute Force Non Greaseable		UJ269
(For Aluminum Drive Shaft)		UJ369C	(For Aluminum Drive Shaft)		UJ369C
Clamp Kit (Fr. Shaft; Frt.)		UJ437-10	Clamp Kit (Fr. Shaft; Frt.)		UJ437-10
U-Joint (Fr. Shaft; Rr.) [⊙]	[2]	UJ379	U-Joint (Fr. Shaft; Rr.) [⊙]	[2]	UJ379
Brute Force Greaseable		UJ280	Brute Force Greaseable		UJ280
Brute Force Non Greaseable		UJ269	Brute Force Non Greaseable		UJ269
U-Joint (Rr. Shaft; Frt.) [⊙]		UJ369	U-Joint (Rr. Shaft; Frt.) [⊙]		UJ369
Brute Force Greaseable		UJ280	Brute Force Greaseable		UJ280
Brute Force Non Greaseable		UJ269	Brute Force Non Greaseable		UJ269
(For Aluminum Drive Shaft)		UJ369C	(For Aluminum Drive Shaft)		UJ369C
Clamp Kit (Rr. Shaft; Frt.)		UJ437-10	Clamp Kit (Rr. Shaft; Frt.)		UJ437-10
U-Joint (Rr. Shaft; Rr.) [⊙]		UJ369	U-Joint (Rr. Shaft; Rr.) [⊙]		UJ369
Brute Force Greaseable		UJ280	Brute Force Greaseable		UJ280
Brute Force Non Greaseable		UJ269	Brute Force Non Greaseable		UJ269
(For Aluminum Drive Shaft)		UJ369C	(For Aluminum Drive Shaft)		UJ369C
Clamp Kit (Rr. Shaft; Rr.)		UJ437-10	Clamp Kit (Rr. Shaft; Rr.)		UJ437-10
U-Joint (Front Axle Left Outer) [⊙]		UJ436	U-Joint (Front Axle Left Outer) [⊙]		UJ371
Brute Force Greaseable		UJ466	Brute Force Greaseable		UJ377
Brute Force Non Greaseable		UJ436	Brute Force Non Greaseable		UJ371
U-Joint (Front Axle Right Inner) [⊙]		UJ436	U-Joint (Front Axle Right Inner) [⊙]		UJ371
Brute Force Greaseable		UJ466	Brute Force Greaseable		UJ377
Brute Force Non Greaseable		UJ436	Brute Force Non Greaseable		UJ371
U-Joint (Front Axle Right Outer) [⊙]		UJ436	U-Joint (Front Axle Right Outer) [⊙]		UJ371
Brute Force Greaseable		UJ466	Brute Force Greaseable		UJ377
Brute Force Non Greaseable		UJ436	Brute Force Non Greaseable		UJ371
H Yoke		UJ647	H Yoke		UJ647

(Continued)

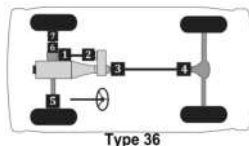

316 ▲ For Use w/ 1.063" Bearing Cap Application. ⊙ For Use w/ 1.188" Bearing Cap Application. ◇ For Use w/ Inner Lock Ring Application on Half Shaft. □ For Use w/ Outer Lock Ring Application on Half Shaft.

Passenger cars, light & medium trucks

(Cont.) -- Ford Truck Aerostar, Bronco II, Excursion, Expedition, Explorer (thru 2010), Explorer Sport Trac, Ranger

MFG./YEAR	MODEL & LOCATION	PART NO.	MFG./YEAR	MODEL & LOCATION	PART NO.
Drive Shaft (4 W/D) (Cont.)			Drive Shaft (4 W/D) (Cont.)		
U-Joint (Cont.)			U-Joint (Cont.)		
1992-1990 Ranger w/ 125" Wheel Base & 1.063" Dia. Brg. Cap Axle Joints: [Type 37]			1992-1990 Ranger w/ 125" Wheel Base & 1.188" Dia. Brg. Cap Axle Joints: [Type 37]		
	U-Joint (Fr. Shaft; Fr.) ^①	UJ369		U-Joint (Fr. Shaft; Fr.) ^①	UJ369
	Brute Force Greaseable	UJ280		Brute Force Greaseable	UJ280
	Brute Force Non Greaseable	UJ269		Brute Force Non Greaseable	UJ269
	(For Aluminum Drive Shaft)	UJ369C		(For Aluminum Drive Shaft)	UJ369C
	Clamp Kit (Fr. Shaft; Fr.)	UJ437-10		Clamp Kit (Fr. Shaft; Fr.)	UJ437-10
	U-Joint (Fr. Shaft; Rr.) ^②	[2] UJ379		U-Joint (Fr. Shaft; Rr.) ^②	[2] UJ379
	Brute Force Greaseable	UJ280		Brute Force Greaseable	UJ280
	Brute Force Non Greaseable	UJ269		Brute Force Non Greaseable	UJ269
	U-Joint (Rr. Shaft; Fr.) ^③	UJ369		U-Joint (Rr. Shaft; Fr.) ^③	UJ369
	Brute Force Greaseable	UJ280		Brute Force Greaseable	UJ280
	Brute Force Non Greaseable	UJ269		Brute Force Non Greaseable	UJ269
	(For Aluminum Drive Shaft)	UJ369C		(For Aluminum Drive Shaft)	UJ369C
	Clamp Kit (Rr. Shaft; Fr.)	UJ437-10		Clamp Kit (Rr. Shaft; Fr.)	UJ437-10
	U-Joint (Rr. Shaft; Ctr.) ^④	UJ369		U-Joint (Rr. Shaft; Ctr.) ^④	UJ369
	Brute Force Greaseable	UJ280		Brute Force Greaseable	UJ280
	Brute Force Non Greaseable	UJ269		Brute Force Non Greaseable	UJ269
	(For Aluminum Drive Shaft)	UJ369C		(For Aluminum Drive Shaft)	UJ369C
	Clamp Kit (Rr. Shaft; Ctr.)	UJ437-10		Clamp Kit (Rr. Shaft; Ctr.)	UJ437-10
	U-Joint (Rr. Shaft; Rr.) ^⑤	UJ369		U-Joint (Rr. Shaft; Rr.) ^⑤	UJ369
	Brute Force Greaseable	UJ280		Brute Force Greaseable	UJ280
	Brute Force Non Greaseable	UJ269		Brute Force Non Greaseable	UJ269
	(For Aluminum Drive Shaft)	UJ369C		(For Aluminum Drive Shaft)	UJ369C
	Clamp Kit (Rr. Shaft; Rr.)	UJ437-10		Clamp Kit (Rr. Shaft; Rr.)	UJ437-10
	U-Joint (Front Axle Left Outer) ^⑥	UJ436		U-Joint (Front Axle Left Outer) ^⑥	UJ371
	Brute Force Greaseable	UJ466		Brute Force Greaseable	UJ377
	Brute Force Non Greaseable	UJ436		Brute Force Non Greaseable	UJ371
	U-Joint (Front Axle Right Inner) ^⑦	UJ436		U-Joint (Front Axle Right Inner) ^⑦	UJ371
	Brute Force Greaseable	UJ466		Brute Force Greaseable	UJ377
	Brute Force Non Greaseable	UJ436		Brute Force Non Greaseable	UJ371
	U-Joint (Front Axle Right Outer) ^⑧	UJ436		U-Joint (Front Axle Right Outer) ^⑧	UJ371
	Brute Force Greaseable	UJ466		Brute Force Greaseable	UJ377
	Brute Force Non Greaseable	UJ436		Brute Force Non Greaseable	UJ371
	H Yoke	UJ647		H Yoke	UJ647

(Continued)

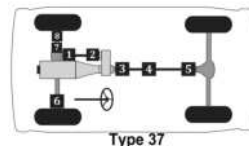

Passenger cars, light & medium trucks

Ford Truck Aerostar, Bronco II, Excursion, Expedition, Explorer (thru 2010), Explorer Sport Trac, Ranger -- (Cont.)

MFG./YEAR	MODEL & LOCATION	PART NO.	MFG./YEAR	MODEL & LOCATION	PART NO.
Drive Shaft (4 W/D) (Cont.)			Drive Shaft (4 W/D) (Cont.)		
U-Joint (Cont.)			U-Joint (Cont.)		
1990	Bronco II w/ 1.063" Dia. Brg. Cap Axle		1989	Ranger w/ 108" Wheel Base & 2.75" Front Shaft Yoke: [Type 36]	
	Joints: [Type 38]				
	U-Joint (Frt. Shaft; Frt.)⊙	UJ369		U-Joint (Frt. Shaft; Frt.)⊙	UJ437G
	Brute Force Greaseable	UJ280		Brute Force Greaseable	UJ240
	Brute Force Non Greaseable	UJ269		Brute Force Non Greaseable	UJ237
	(For Aluminum Drive Shaft)	UJ369C		Clamp Kit (Frt. Shaft; Frt.)	UJ437-10
	Clamp Kit (Frt. Shaft; Frt.)	UJ437-10		U-Joint (Frt. Shaft; Rr.)⊙	UJ437G
	U-Joint (Frt. Shaft; Rr.)⊙	[2] UJ379		Brute Force Greaseable	UJ240
	Brute Force Greaseable	UJ280		Brute Force Non Greaseable	UJ237
	Brute Force Non Greaseable	UJ269		Clamp Kit (Frt. Shaft; Rr.)	UJ437-10
	U-Joint (Front Axle Left Outer)⊙	UJ436		U-Joint (Rr. Shaft; Frt.)⊙	[2] UJ379
	Brute Force Greaseable	UJ466		Brute Force Greaseable	UJ280
	Brute Force Non Greaseable	UJ436		Brute Force Non Greaseable	UJ269
	U-Joint (Front Axle Right Inner)⊙	UJ436		U-Joint (Rr. Shaft; Rr.)⊙	UJ369
	Brute Force Greaseable	UJ466		Brute Force Greaseable	UJ280
	Brute Force Non Greaseable	UJ436		Brute Force Non Greaseable	UJ269
	U-Joint (Front Axle Right Outer)⊙	UJ436		(For Aluminum Drive Shaft)	UJ369C
	Brute Force Greaseable	UJ466		U-Joint (Front Axle Left Outer)⊙	UJ436
	Brute Force Non Greaseable	UJ436		Brute Force Greaseable	UJ466
	H Yoke	UJ647		Brute Force Non Greaseable	UJ436
1990	Bronco II w/ 1.188" Dia. Brg. Cap Axle			U-Joint (Front Axle Right Inner)⊙	UJ436
	Joints: [Type 38]			Brute Force Greaseable	UJ466
	U-Joint (Frt. Shaft; Frt.)⊙	UJ369		Brute Force Non Greaseable	UJ436
	Brute Force Greaseable	UJ280		U-Joint (Front Axle Right Outer)⊙	UJ436
	Brute Force Non Greaseable	UJ269		Brute Force Greaseable	UJ466
	(For Aluminum Drive Shaft)	UJ369C		Brute Force Non Greaseable	UJ436
	Clamp Kit (Frt. Shaft; Frt.)	UJ437-10		H Yoke	UJ647
	U-Joint (Frt. Shaft; Rr.)⊙	[2] UJ379			(Continued)
	Brute Force Greaseable	UJ280			
	Brute Force Non Greaseable	UJ269			
	U-Joint (Front Axle Left Outer)⊙	UJ371			
	Brute Force Greaseable	UJ377			
	Brute Force Non Greaseable	UJ371			
	U-Joint (Front Axle Right Inner)⊙	UJ371			
	Brute Force Greaseable	UJ377			
	Brute Force Non Greaseable	UJ371			
	U-Joint (Front Axle Right Outer)⊙	UJ371			
	Brute Force Greaseable	UJ377			
	Brute Force Non Greaseable	UJ371			
	H Yoke	UJ647			

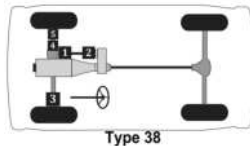
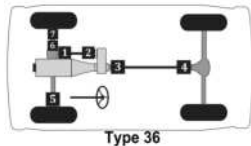

318 ▲ For Use w/ 1.063" Bearing Cap Application. ⊙ For Use w/ 1.188" Bearing Cap Application. ◇ For Use w/ Inner Lock Ring Application on Half Shaft. □ For Use w/ Outer Lock Ring Application on Half Shaft.

Passenger cars, light & medium trucks

(Cont.) -- Ford Truck Aerostar, Bronco II, Excursion, Expedition, Explorer (thru 2010), Explorer Sport Trac, Ranger

MFG./YEAR	MODEL & LOCATION	PART NO.	MFG./YEAR	MODEL & LOCATION	PART NO.
Drive Shaft (4 W/D) (Cont.)			Drive Shaft (4 W/D) (Cont.)		
U-Joint (Cont.)			U-Joint (Cont.)		
1989	Ranger w/ 108" Wheel Base & 3.5" Front Shaft Yoke: [Type 36]		1989-1988	Ranger w/ 114" Wheel Base & 2.75" Front Shaft Yoke: [Type 36]	
	U-Joint (Fr. Shaft; Fr.) ①	UJ369		U-Joint (Fr. Shaft; Fr.) ①	UJ437G
	Brute Force Greaseable	UJ280		Brute Force Greaseable	UJ240
	Brute Force Non Greaseable	UJ269		Brute Force Non Greaseable	UJ237
	(For Aluminum Drive Shaft)	UJ369C		Clamp Kit (Fr. Shaft; Fr.)	UJ437-10
	U-Joint (Fr. Shaft; Rr.) ②	UJ369		U-Joint (Fr. Shaft; Rr.) ②	UJ437G
	Brute Force Greaseable	UJ280		Brute Force Greaseable	UJ240
	Brute Force Non Greaseable	UJ269		Brute Force Non Greaseable	UJ237
	(For Aluminum Drive Shaft)	UJ369C		Clamp Kit (Fr. Shaft; Rr.)	UJ437-10
	U-Joint (Rr. Shaft; Fr.) ③	[2] UJ379		U-Joint (Rr. Shaft; Fr.) ③	UJ437G
	Brute Force Greaseable	UJ280		Brute Force Greaseable	UJ240
	Brute Force Non Greaseable	UJ269		Brute Force Non Greaseable	UJ237
	U-Joint (Rr. Shaft; Rr.) ④	UJ369		U-Joint (Rr. Shaft; Rr.) ④	UJ437G
	Brute Force Greaseable	UJ280		Brute Force Greaseable	UJ240
	Brute Force Non Greaseable	UJ269		Brute Force Non Greaseable	UJ237
	(For Aluminum Drive Shaft)	UJ369C		Clamp Kit (Rr. Shaft; Fr.)	UJ437-10
	U-Joint (Front Axle Left Outer) ⑤	UJ436		U-Joint (Front Axle Left Outer) ⑤	UJ436
	Brute Force Greaseable	UJ466		Brute Force Greaseable	UJ466
	Brute Force Non Greaseable	UJ436		Brute Force Non Greaseable	UJ436
	U-Joint (Front Axle Right Inner) ⑥	UJ436		U-Joint (Front Axle Right Inner) ⑥	UJ436
	Brute Force Greaseable	UJ466		Brute Force Greaseable	UJ466
	Brute Force Non Greaseable	UJ436		Brute Force Non Greaseable	UJ436
	U-Joint (Front Axle Right Outer) ⑦	UJ436		U-Joint (Front Axle Right Outer) ⑦	UJ436
	Brute Force Greaseable	UJ466		Brute Force Greaseable	UJ466
	Brute Force Non Greaseable	UJ436		Brute Force Non Greaseable	UJ436
	H Yoke	UJ647		Brute Force Greaseable	UJ466
				Brute Force Non Greaseable	UJ436

(Continued)

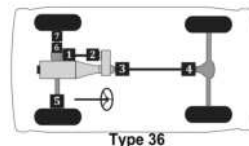

Passenger cars, light & medium trucks

Ford Truck Aerostar, Bronco II, Excursion, Expedition, Explorer (thru 2010), Explorer Sport Trac, Ranger -- (Cont.)

MFG./YEAR	MODEL & LOCATION	PART NO.	MFG./YEAR	MODEL & LOCATION	PART NO.
Drive Shaft (4 W/D) (Cont.)			Drive Shaft (4 W/D) (Cont.)		
U-Joint (Cont.)			U-Joint (Cont.)		
1989-1988 Ranger w/ 114" Wheel Base & 3.5" Front Shaft Yoke: [Type 36]			1989-1988 Ranger w/ 125" Wheel Base & 2.75" Front Shaft Yoke: [Type 37]		
	U-Joint (Frt. Shaft; Frt.) ^①	UJ369		U-Joint (Frt. Shaft; Frt.) ^①	UJ437G
	Brute Force Greaseable	UJ280		Brute Force Greaseable	UJ240
	Brute Force Non Greaseable	UJ269		Brute Force Non Greaseable	UJ237
	(For Aluminum Drive Shaft)	UJ369C		Clamp Kit (Frt. Shaft; Frt.)	UJ437-10
	U-Joint (Frt. Shaft; Rr.) ^②	UJ369		U-Joint (Frt. Shaft; Rr.) ^②	UJ437G
	Brute Force Greaseable	UJ280		Brute Force Greaseable	UJ240
	Brute Force Non Greaseable	UJ269		Brute Force Non Greaseable	UJ237
	(For Aluminum Drive Shaft)	UJ369C		Clamp Kit (Frt. Shaft; Rr.)	UJ437-10
	U-Joint (Rr. Shaft; Frt.) ^③	UJ437G		U-Joint (Rr. Shaft; Frt.) ^③	UJ437G
	Brute Force Greaseable	UJ240		Brute Force Greaseable	UJ240
	Brute Force Non Greaseable	UJ237		Brute Force Non Greaseable	UJ237
	Clamp Kit (Rr. Shaft; Frt.)	UJ437-10		Clamp Kit (Rr. Shaft; Frt.)	UJ437-10
	U-Joint (Rr. Shaft; Rr.) ^④	UJ437G		U-Joint (Rr. Shaft; Ctr.) ^⑤	UJ437G
	Brute Force Greaseable	UJ240		Brute Force Greaseable	UJ240
	Brute Force Non Greaseable	UJ237		Brute Force Non Greaseable	UJ237
	Clamp Kit (Rr. Shaft; Rr.)	UJ437-10		Clamp Kit (Rr. Shaft; Ctr.)	UJ437-10
	U-Joint (Front Axle Left Outer) ^⑥	UJ436		U-Joint (Rr. Shaft; Rr.) ^⑥	UJ437G
	Brute Force Greaseable	UJ466		Brute Force Greaseable	UJ240
	Brute Force Non Greaseable	UJ436		Brute Force Non Greaseable	UJ237
	U-Joint (Front Axle Right Inner) ^⑦	UJ436		Clamp Kit (Rr. Shaft; Rr.)	UJ437-10
	Brute Force Greaseable	UJ466		U-Joint (Front Axle Left Outer) ^⑧	UJ436
	Brute Force Non Greaseable	UJ436		Brute Force Greaseable	UJ466
	U-Joint (Front Axle Right Outer) ^⑨	UJ436		Brute Force Non Greaseable	UJ436
	Brute Force Greaseable	UJ466		U-Joint (Front Axle Right Inner) ^⑩	UJ436
	Brute Force Non Greaseable	UJ436		Brute Force Greaseable	UJ466
				Brute Force Non Greaseable	UJ436
				U-Joint (Front Axle Right Outer) ^⑪	UJ436
				Brute Force Greaseable	UJ466
				Brute Force Non Greaseable	UJ436

(Continued)

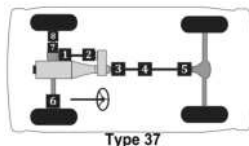
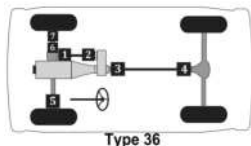

Passenger cars, light & medium trucks

(Cont.) -- Ford Truck Aerostar, Bronco II, Excursion, Expedition, Explorer (thru 2010), Explorer Sport Trac, Ranger

MFG./YEAR	MODEL & LOCATION	PART NO.	MFG./YEAR	MODEL & LOCATION	PART NO.
Drive Shaft (4 W/D) (Cont.)			Drive Shaft (4 W/D) (Cont.)		
U-Joint (Cont.)			U-Joint (Cont.)		
1989-1988 Ranger w/ 125" Wheel Base & 3.5" Front Shaft Yoke: [Type 37]			1989-1986 Bronco II w/ 2 Joint Front Shaft: [Type 38]		
	U-Joint (Fr. Shaft; Frt.) ①	UJ369		U-Joint (Fr. Shaft; Frt.) ①	UJ369
	<i>Brute Force Greaseable</i>	UJ280		<i>Brute Force Greaseable</i>	UJ280
	<i>Brute Force Non Greaseable</i>	UJ269		<i>Brute Force Non Greaseable</i>	UJ269
	(For Aluminum Drive Shaft)	UJ369C		(For Aluminum Drive Shaft)	UJ369C
	U-Joint (Fr. Shaft; Rr.) ②	UJ369		U-Joint (Fr. Shaft; Rr.) ②	UJ369
	<i>Brute Force Greaseable</i>	UJ280		<i>Brute Force Greaseable</i>	UJ280
	<i>Brute Force Non Greaseable</i>	UJ269		<i>Brute Force Non Greaseable</i>	UJ269
	(For Aluminum Drive Shaft)	UJ369C		(For Aluminum Drive Shaft)	UJ369C
	U-Joint (Rr. Shaft; Frt.) ③	UJ437G		U-Joint (Front Axle Left Outer) ④	UJ436
	<i>Brute Force Greaseable</i>	UJ240		<i>Brute Force Greaseable</i>	UJ466
	<i>Brute Force Non Greaseable</i>	UJ237		<i>Brute Force Non Greaseable</i>	UJ436
	Clamp Kit (Rr. Shaft; Frt.)	UJ437-10		U-Joint (Front Axle Right Inner) ④	UJ436
	U-Joint (Rr. Shaft; Ctr.) ④	UJ437G		<i>Brute Force Greaseable</i>	UJ466
	<i>Brute Force Greaseable</i>	UJ240		<i>Brute Force Non Greaseable</i>	UJ436
	<i>Brute Force Non Greaseable</i>	UJ237		U-Joint (Front Axle Right Outer) ⑤	UJ436
	Clamp Kit (Rr. Shaft; Ctr.)	UJ437-10		<i>Brute Force Greaseable</i>	UJ466
	U-Joint (Rr. Shaft; Rr.) ⑤	UJ437G		<i>Brute Force Non Greaseable</i>	UJ436
	<i>Brute Force Greaseable</i>	UJ240		1989-1986 Bronco II w/ 3 Joint Front Shaft: [Type 38]	
	<i>Brute Force Non Greaseable</i>	UJ237		U-Joint (Fr. Shaft; Frt.) ①	UJ369
	Clamp Kit (Rr. Shaft; Rr.)	UJ437-10		<i>Brute Force Greaseable</i>	UJ280
	U-Joint (Front Axle Left Outer) ⑥	UJ436		<i>Brute Force Non Greaseable</i>	UJ269
	<i>Brute Force Greaseable</i>	UJ466		(For Aluminum Drive Shaft)	UJ369C
	<i>Brute Force Non Greaseable</i>	UJ436		Clamp Kit (Fr. Shaft; Frt.)	UJ437-10
	U-Joint (Front Axle Right Inner) ⑦	UJ436		U-Joint (Fr. Shaft; Rr.) ②	[2] UJ379
	<i>Brute Force Greaseable</i>	UJ466		<i>Brute Force Greaseable</i>	UJ280
	<i>Brute Force Non Greaseable</i>	UJ436		<i>Brute Force Non Greaseable</i>	UJ269
	U-Joint (Front Axle Right Outer) ⑧	UJ436		U-Joint (Front Axle Left Outer) ⑥	UJ436
	<i>Brute Force Greaseable</i>	UJ466		<i>Brute Force Greaseable</i>	UJ466
	<i>Brute Force Non Greaseable</i>	UJ436		<i>Brute Force Non Greaseable</i>	UJ436
				U-Joint (Front Axle Right Inner) ④	UJ436
				<i>Brute Force Greaseable</i>	UJ466
				<i>Brute Force Non Greaseable</i>	UJ436
				U-Joint (Front Axle Right Outer) ⑤	UJ436
				<i>Brute Force Greaseable</i>	UJ466
				<i>Brute Force Non Greaseable</i>	UJ436
				H Yoke	UJ647

(Continued)

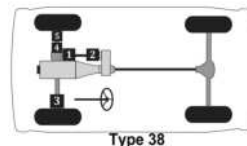
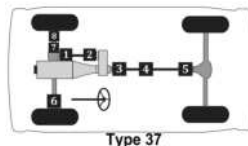

Passenger cars, light & medium trucks

Ford Truck Aerostar, Bronco II, Excursion, Expedition, Explorer (thru 2010), Explorer Sport Trac, Ranger -- (Cont.)

MFG./YEAR	MODEL & LOCATION	PART NO.	MFG./YEAR	MODEL & LOCATION	PART NO.
Drive Shaft (4 W/D) (Cont.)			Drive Shaft (4 W/D) (Cont.)		
U-Joint (Cont.)			U-Joint (Cont.)		
1988	Ranger w/ 108" Wheel Base & 2.75" Front Shaft Yoke: [Type 36]		1988	Ranger w/ 108" Wheel Base & 3.5" Front Shaft Yoke: [Type 36]	
	U-Joint (Fr. Shaft; Fr.) ^①	UJ437G		U-Joint (Fr. Shaft; Fr.) ^①	UJ369
	Brute Force Greaseable	UJ240		Brute Force Greaseable	UJ280
	Brute Force Non Greaseable	UJ237		Brute Force Non Greaseable	UJ269
	Clamp Kit (Fr. Shaft; Fr.)	UJ437-10		(For Aluminum Drive Shaft)	UJ369C
	U-Joint (Fr. Shaft; Rr.) ^②	UJ437G		U-Joint (Fr. Shaft; Rr.) ^②	UJ369
	Brute Force Greaseable	UJ240		Brute Force Greaseable	UJ280
	Brute Force Non Greaseable	UJ237		Brute Force Non Greaseable	UJ269
	Clamp Kit (Fr. Shaft; Rr.)	UJ437-10		(For Aluminum Drive Shaft)	UJ369C
	U-Joint (Rr. Shaft; Fr.) ^③	[2] UJ437G		U-Joint (Rr. Shaft; Fr.) ^③	[2] UJ437G
	Brute Force Greaseable	UJ240		Brute Force Greaseable	UJ240
	Brute Force Non Greaseable	UJ237		Brute Force Non Greaseable	UJ237
	Clamp Kit (Rr. Shaft; Fr.)	UJ437-10		Clamp Kit (Rr. Shaft; Fr.)	UJ437-10
	U-Joint (Rr. Shaft; Rr.) ^④	UJ437G		U-Joint (Rr. Shaft; Rr.) ^④	UJ437G
	Brute Force Greaseable	UJ240		Brute Force Greaseable	UJ240
	Brute Force Non Greaseable	UJ237		Brute Force Non Greaseable	UJ237
	Clamp Kit (Rr. Shaft; Rr.)	UJ437-10		Clamp Kit (Rr. Shaft; Rr.)	UJ437-10
	U-Joint (Front Axle Left Outer) ^⑤	UJ436		U-Joint (Front Axle Left Outer) ^⑤	UJ436
	Brute Force Greaseable	UJ466		Brute Force Greaseable	UJ466
	Brute Force Non Greaseable	UJ436		Brute Force Non Greaseable	UJ436
	U-Joint (Front Axle Right Inner) ^⑥	UJ436		U-Joint (Front Axle Right Inner) ^⑥	UJ436
	Brute Force Greaseable	UJ466		Brute Force Greaseable	UJ466
	Brute Force Non Greaseable	UJ436		Brute Force Non Greaseable	UJ436
	U-Joint (Front Axle Right Outer) ^⑦	UJ436		U-Joint (Front Axle Right Outer) ^⑦	UJ436
	Brute Force Greaseable	UJ466		Brute Force Greaseable	UJ466
	Brute Force Non Greaseable	UJ436		Brute Force Non Greaseable	UJ436

(Continued)

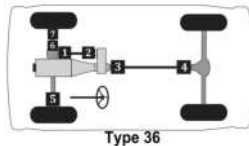

322 ▲ For Use w/ 1.063" Bearing Cap Application. ⊙ For Use w/ 1.188" Bearing Cap Application. ◇ For Use w/ Inner Lock Ring Application on Half Shaft. □ For Use w/ Outer Lock Ring Application on Half Shaft.

Passenger cars, light & medium trucks

(Cont.) -- Ford Truck Aerostar, Bronco II, Excursion, Expedition, Explorer (thru 2010), Explorer Sport Trac, Ranger

MFG./YEAR	MODEL & LOCATION	PART NO.	MFG./YEAR	MODEL & LOCATION	PART NO.
Drive Shaft (4 W/D) (Cont.)			Drive Shaft (4 W/D) (Cont.)		
U-Joint (Cont.)			U-Joint (Cont.)		
1987	Ranger STX w/ 114" & 125" Wheel Base: [Type 36]		1987	Ranger STX w/ 108" Wheel Base: [Type 36]	
	U-Joint (Frt. Shaft; Frt.) ^①	UJ437G		U-Joint (Frt. Shaft; Frt.) ^①	UJ437G
	Brute Force Greaseable	UJ240		Brute Force Greaseable	UJ240
	Brute Force Non Greaseable	UJ237		Brute Force Non Greaseable	UJ237
	Clamp Kit (Frt. Shaft; Frt.)	UJ437-10		Clamp Kit (Frt. Shaft; Frt.)	UJ437-10
	U-Joint (Frt. Shaft; Rr.) ^②	UJ437G		U-Joint (Frt. Shaft; Rr.) ^②	UJ437G
	Brute Force Greaseable	UJ240		Brute Force Greaseable	UJ240
	Brute Force Non Greaseable	UJ237		Brute Force Non Greaseable	UJ237
	Clamp Kit (Frt. Shaft; Rr.)	UJ437-10		Clamp Kit (Frt. Shaft; Rr.)	UJ437-10
	U-Joint (Rr. Shaft; Frt.) ^③	UJ437G		U-Joint (Rr. Shaft; Frt.) ^③	[2] UJ437G
	Brute Force Greaseable	UJ240		Brute Force Greaseable	UJ240
	Brute Force Non Greaseable	UJ237		Brute Force Non Greaseable	UJ237
	Clamp Kit (Rr. Shaft; Frt.)	UJ437-10		Clamp Kit (Rr. Shaft; Frt.)	UJ437-10
	U-Joint (Rr. Shaft; Rr.) ^④	UJ437G		U-Joint (Rr. Shaft; Rr.) ^④	UJ437G
	Brute Force Greaseable	UJ240		Brute Force Greaseable	UJ240
	Brute Force Non Greaseable	UJ237		Brute Force Non Greaseable	UJ237
	Clamp Kit (Rr. Shaft; Rr.)	UJ437-10		Clamp Kit (Rr. Shaft; Rr.)	UJ437-10
	U-Joint (Front Axle Left Outer) ^⑤	UJ436		U-Joint (Front Axle Left Outer) ^⑤	UJ436
	Brute Force Greaseable	UJ466		Brute Force Greaseable	UJ466
	Brute Force Non Greaseable	UJ436		Brute Force Non Greaseable	UJ436
	U-Joint (Front Axle Right Inner) ^⑥	UJ436		U-Joint (Front Axle Right Inner) ^⑥	UJ436
	Brute Force Greaseable	UJ466		Brute Force Greaseable	UJ466
	Brute Force Non Greaseable	UJ436		Brute Force Non Greaseable	UJ436
	U-Joint (Front Axle Right Outer) ^⑦	UJ436		U-Joint (Front Axle Right Outer) ^⑦	UJ436
	Brute Force Greaseable	UJ466		Brute Force Greaseable	UJ466
	Brute Force Non Greaseable	UJ436		Brute Force Non Greaseable	UJ436

(Continued)

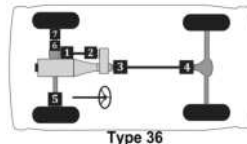

Passenger cars, light & medium trucks

Ford Truck Aerostar, Bronco II, Excursion, Expedition, Explorer (thru 2010), Explorer Sport Trac, Ranger -- (Cont.)

MFG./YEAR	MODEL & LOCATION	PART NO.	MFG./YEAR	MODEL & LOCATION	PART NO.
Drive Shaft (4 W/D) (Cont.)			Drive Shaft (4 W/D) (Cont.)		
U-Joint (Cont.)			U-Joint (Cont.)		
1987	Ranger w/ 114" & 125" Wheel Base Exc. STX: [Type 36]		1987	Ranger w/ 108" Wheel Base Exc. STX: [Type 36]	
	U-Joint (Fr. Shaft; Fr.) [Ⓚ]	UJ369		U-Joint (Fr. Shaft; Fr.) [Ⓚ]	UJ369
	Brute Force Greaseable	UJ280		Brute Force Greaseable	UJ280
	Brute Force Non Greaseable	UJ269		Brute Force Non Greaseable	UJ269
	(For Aluminum Drive Shaft)	UJ369C		(For Aluminum Drive Shaft)	UJ369C
	U-Joint (Fr. Shaft; Rr.) [Ⓛ]	UJ369		U-Joint (Fr. Shaft; Rr.) [Ⓛ]	UJ369
	Brute Force Greaseable	UJ280		Brute Force Greaseable	UJ280
	Brute Force Non Greaseable	UJ269		Brute Force Non Greaseable	UJ269
	(For Aluminum Drive Shaft)	UJ369C		(For Aluminum Drive Shaft)	UJ369C
	U-Joint (Rr. Shaft; Fr.) [Ⓛ]	UJ437G		U-Joint (Rr. Shaft; Fr.) [Ⓛ]	UJ437G
	Brute Force Greaseable	UJ240		Brute Force Greaseable	UJ240
	Brute Force Non Greaseable	UJ237		Brute Force Non Greaseable	UJ237
	Clamp Kit (Rr. Shaft; Fr.)	UJ437-10		Clamp Kit (Rr. Shaft; Fr.)	UJ437-10
	U-Joint (Rr. Shaft; Rr.) [Ⓛ]	UJ437G		U-Joint (Rr. Shaft; Rr.) [Ⓛ]	UJ437G
	Brute Force Greaseable	UJ240		Brute Force Greaseable	UJ240
	Brute Force Non Greaseable	UJ237		Brute Force Non Greaseable	UJ237
	Clamp Kit (Rr. Shaft; Rr.)	UJ437-10		Clamp Kit (Rr. Shaft; Rr.)	UJ437-10
	U-Joint (Front Axle Left Outer) [Ⓛ]	UJ436		U-Joint (Front Axle Left Outer) [Ⓛ]	UJ436
	Brute Force Greaseable	UJ466		Brute Force Greaseable	UJ466
	Brute Force Non Greaseable	UJ436		Brute Force Non Greaseable	UJ436
	U-Joint (Front Axle Right Inner) [Ⓛ]	UJ436		U-Joint (Front Axle Right Inner) [Ⓛ]	UJ436
	Brute Force Greaseable	UJ466		Brute Force Greaseable	UJ466
	Brute Force Non Greaseable	UJ436		Brute Force Non Greaseable	UJ436
	U-Joint (Front Axle Right Outer) [Ⓛ]	UJ436		U-Joint (Front Axle Right Outer) [Ⓛ]	UJ436
	Brute Force Greaseable	UJ466		Brute Force Greaseable	UJ466
	Brute Force Non Greaseable	UJ436		Brute Force Non Greaseable	UJ436

(Continued)

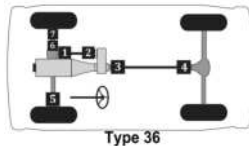

324 ▲ For Use w/ 1.063" Bearing Cap Application. Ⓚ For Use w/ 1.188" Bearing Cap Application. ◇ For Use w/ Inner Lock Ring Application on Half Shaft. □ For Use w/ Outer Lock Ring Application on Half Shaft.

Passenger cars, light & medium trucks

(Cont.) -- Ford Truck Aerostar, Bronco II, Excursion, Expedition, Explorer (thru 2010), Explorer Sport Trac, Ranger

MFG./YEAR	MODEL & LOCATION	PART NO.	MFG./YEAR	MODEL & LOCATION	PART NO.
Drive Shaft (4 W/D) (Cont.)			Drive Shaft (4 W/D) (Cont.)		
U-Joint (Cont.)			U-Joint (Cont.)		
1986	Ranger w/ 125" Wheel Base & 5 Spd. Man. Trans.: [Type 36]		1986	Ranger w/ 125" Wheel Base & Exc. 5 Spd. Man. Trans.: [Type 36]	
	U-Joint (Fr. Shaft; Fr.) ^①	UJ369		U-Joint (Fr. Shaft; Fr.) ^①	UJ369
	Brute Force Greaseable	UJ280		Brute Force Greaseable	UJ280
	Brute Force Non Greaseable	UJ269		Brute Force Non Greaseable	UJ269
	(For Aluminum Drive Shaft)	UJ369C		(For Aluminum Drive Shaft)	UJ369C
	U-Joint (Fr. Shaft; Rr.) ^②	UJ369		U-Joint (Fr. Shaft; Rr.) ^②	UJ369
	Brute Force Greaseable	UJ280		Brute Force Greaseable	UJ280
	Brute Force Non Greaseable	UJ269		Brute Force Non Greaseable	UJ269
	(For Aluminum Drive Shaft)	UJ369C		(For Aluminum Drive Shaft)	UJ369C
	U-Joint (Rr. Shaft; Fr.) ^③	UJ354		U-Joint (Rr. Shaft; Fr.) ^③	UJ437G
	Brute Force Greaseable	UJ270		Brute Force Greaseable	UJ240
	Brute Force Non Greaseable	UJ254		Brute Force Non Greaseable	UJ237
	(For Aluminum Drive Shaft)	UJ354C		Clamp Kit (Rr. Shaft; Fr.)	UJ437-10
	U-Joint (Rr. Shaft; Rr.) ^④	UJ434		U-Joint (Rr. Shaft; Rr.) ^④	UJ437G
	Brute Force Greaseable	UJ265		Brute Force Greaseable	UJ240
	Brute Force Non Greaseable	UJ264		Brute Force Non Greaseable	UJ237
	U-Joint (Front Axle Left Outer) ^⑤	UJ436		Clamp Kit (Rr. Shaft; Rr.)	UJ437-10
	Brute Force Greaseable	UJ466		U-Joint (Front Axle Left Outer) ^⑤	UJ436
	Brute Force Non Greaseable	UJ436		Brute Force Greaseable	UJ466
	U-Joint (Front Axle Right Inner) ^⑥	UJ436		Brute Force Non Greaseable	UJ436
	Brute Force Greaseable	UJ466		U-Joint (Front Axle Right Inner) ^⑥	UJ436
	Brute Force Non Greaseable	UJ436		Brute Force Greaseable	UJ466
	U-Joint (Front Axle Right Outer) ^⑦	UJ436		Brute Force Non Greaseable	UJ436
	Brute Force Greaseable	UJ466		U-Joint (Front Axle Right Outer) ^⑦	UJ436
	Brute Force Non Greaseable	UJ436		Brute Force Greaseable	UJ466
				Brute Force Non Greaseable	UJ436

(Continued)

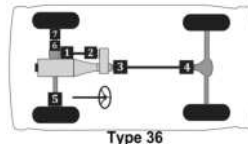

Passenger cars, light & medium trucks

Ford Truck Aerostar, Bronco II, Excursion, Expedition, Explorer (thru 2010), Explorer Sport Trac, Ranger -- (Cont.)

MFG./YEAR	MODEL & LOCATION	PART NO.	MFG./YEAR	MODEL & LOCATION	PART NO.
Drive Shaft (4 W/D) (Cont.)			Drive Shaft (4 W/D) (Cont.)		
U-Joint (Cont.)			U-Joint (Cont.)		
1986-1985 Ranger w/ 108" Wheel Base: [Type 36]			1986-1985 Ranger w/ 114" Wheel Base: [Type 36]		
	U-Joint (Fr. Shaft; Frt.) [ⓐ]	UJ369		U-Joint (Fr. Shaft; Frt.) [ⓐ]	UJ369
	Brute Force Greaseable	UJ280		Brute Force Greaseable	UJ280
	Brute Force Non Greaseable	UJ269		Brute Force Non Greaseable	UJ269
	(For Aluminum Drive Shaft)	UJ369C		(For Aluminum Drive Shaft)	UJ369C
	U-Joint (Fr. Shaft; Rr.) [ⓑ]	UJ369		U-Joint (Fr. Shaft; Rr.) [ⓑ]	UJ369
	Brute Force Greaseable	UJ280		Brute Force Greaseable	UJ280
	Brute Force Non Greaseable	UJ269		Brute Force Non Greaseable	UJ269
	(For Aluminum Drive Shaft)	UJ369C		(For Aluminum Drive Shaft)	UJ369C
	U-Joint (Rr. Shaft; Frt.) [ⓐ]	[2] UJ437G		U-Joint (Rr. Shaft; Frt.) [ⓐ]	UJ437G
	Brute Force Greaseable	UJ240		Brute Force Greaseable	UJ240
	Brute Force Non Greaseable	UJ237		Brute Force Non Greaseable	UJ237
	Clamp Kit (Rr. Shaft; Frt.)	UJ437-10		Clamp Kit (Rr. Shaft; Frt.)	UJ437-10
	U-Joint (Rr. Shaft; Rr.) [ⓑ]	UJ437G		U-Joint (Rr. Shaft; Rr.) [ⓑ]	UJ437G
	Brute Force Greaseable	UJ240		Brute Force Greaseable	UJ240
	Brute Force Non Greaseable	UJ237		Brute Force Non Greaseable	UJ237
	Clamp Kit (Rr. Shaft; Rr.)	UJ437-10		Clamp Kit (Rr. Shaft; Rr.)	UJ437-10
	U-Joint (Front Axle Left Outer) [ⓐ]	UJ436		U-Joint (Front Axle Left Outer) [ⓐ]	UJ436
	Brute Force Greaseable	UJ466		Brute Force Greaseable	UJ466
	Brute Force Non Greaseable	UJ436		Brute Force Non Greaseable	UJ436
	U-Joint (Front Axle Right Inner) [ⓐ]	UJ436		U-Joint (Front Axle Right Inner) [ⓐ]	UJ436
	Brute Force Greaseable	UJ466		Brute Force Greaseable	UJ466
	Brute Force Non Greaseable	UJ436		Brute Force Non Greaseable	UJ436
	U-Joint (Front Axle Right Outer) [ⓑ]	UJ436		U-Joint (Front Axle Right Outer) [ⓑ]	UJ436
	Brute Force Greaseable	UJ466		Brute Force Greaseable	UJ466
	Brute Force Non Greaseable	UJ436		Brute Force Non Greaseable	UJ436

(Continued)

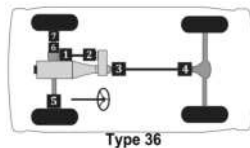

326 ▲ For Use w/ 1.063" Bearing Cap Application. ⓐ For Use w/ 1.188" Bearing Cap Application. ◇ For Use w/ Inner Lock Ring Application on Half Shaft. □ For Use w/ Outer Lock Ring Application on Half Shaft.



Passenger cars, light & medium trucks

(Cont.) -- Ford Truck Aerostar, Bronco II, Excursion, Expedition, Explorer (thru 2010), Explorer Sport Trac, Ranger

MFG./YEAR	MODEL & LOCATION	PART NO.	MFG./YEAR	MODEL & LOCATION	PART NO.
Drive Shaft (4 W/D) (Cont.)			Drive Shaft (4 W/D) (Cont.)		
U-Joint (Cont.)			U-Joint (Cont.)		
1985-1984 Bronco II w/ Auto. Trans.: [Type 36]			1985-1984 Bronco II w/ 4 Spd. Man. Trans.:		
U-Joint (Frnt. Shaft; Frt.)①			[Type 36]		
	<i>Brute Force Greaseable</i>	UJ369		U-Joint (Frnt. Shaft; Frt.)①	UJ369
	<i>Brute Force Non Greaseable</i>	UJ280		<i>Brute Force Greaseable</i>	UJ280
	(For Aluminum Drive Shaft)	UJ369C		<i>Brute Force Non Greaseable</i>	UJ269
	U-Joint (Frnt. Shaft; Rr.)②	UJ369		(For Aluminum Drive Shaft)	UJ369C
	<i>Brute Force Greaseable</i>	UJ280		U-Joint (Frnt. Shaft; Rr.)②	UJ369
	<i>Brute Force Non Greaseable</i>	UJ269		<i>Brute Force Greaseable</i>	UJ280
	(For Aluminum Drive Shaft)	UJ369C		<i>Brute Force Non Greaseable</i>	UJ269
	U-Joint (Rr. Shaft; Frt.)③	[2] UJ437G		(For Aluminum Drive Shaft)	UJ369C
	<i>Brute Force Greaseable</i>	UJ240		U-Joint (Rr. Shaft; Frt.)③	[2] UJ437G
	<i>Brute Force Non Greaseable</i>	UJ237		<i>Brute Force Greaseable</i>	UJ240
	Clamp Kit (Rr. Shaft; Frt.)	UJ437-10		<i>Brute Force Non Greaseable</i>	UJ237
	U-Joint (Rr. Shaft; Rr.)④	UJ437G		Clamp Kit (Rr. Shaft; Frt.)	UJ437-10
	<i>Brute Force Greaseable</i>	UJ240		U-Joint (Rr. Shaft; Rr.)④	UJ437G
	<i>Brute Force Non Greaseable</i>	UJ237		<i>Brute Force Greaseable</i>	UJ240
	Clamp Kit (Rr. Shaft; Rr.)	UJ437-10		<i>Brute Force Non Greaseable</i>	UJ237
	U-Joint (Front Axle Left Outer)⑤	UJ436		Clamp Kit (Rr. Shaft; Rr.)	UJ437-10
	<i>Brute Force Greaseable</i>	UJ466		U-Joint (Front Axle Left Outer)⑤	UJ436
	<i>Brute Force Non Greaseable</i>	UJ436		<i>Brute Force Greaseable</i>	UJ466
	U-Joint (Front Axle Right Inner)⑥	UJ436		<i>Brute Force Non Greaseable</i>	UJ436
	<i>Brute Force Greaseable</i>	UJ466		U-Joint (Front Axle Right Inner)⑥	UJ436
	<i>Brute Force Non Greaseable</i>	UJ436		<i>Brute Force Greaseable</i>	UJ466
	U-Joint (Front Axle Right Outer)⑦	UJ436		<i>Brute Force Non Greaseable</i>	UJ436
	<i>Brute Force Greaseable</i>	UJ466		U-Joint (Front Axle Right Outer)⑦	UJ436
	<i>Brute Force Non Greaseable</i>	UJ436		<i>Brute Force Greaseable</i>	UJ466
				<i>Brute Force Non Greaseable</i>	UJ436

(Continued)

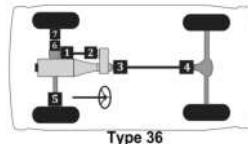

Passenger cars, light & medium trucks

Ford Truck Aerostar, Bronco II, Excursion, Expedition, Explorer (thru 2010), Explorer Sport Trac, Ranger -- (Cont.)

MFG./YEAR	MODEL & LOCATION	PART NO.	MFG./YEAR	MODEL & LOCATION	PART NO.
Drive Shaft (4 W/D) (Cont.)			Drive Shaft (4 W/D) (Cont.)		
U-Joint (Cont.)			U-Joint (Cont.)		
1985-1984 Bronco II w/ 5 Spd. Man. Trans. From 9/83: [Type 36]			1984 Bronco II w/ 5 Spd. Man. Trans. Thru 8/83: [Type 36]		
	U-Joint (Fr. Shaft; Fr.) [ⓐ]	UJ369		U-Joint (Fr. Shaft; Fr.) [ⓐ]	UJ369
	Brute Force Greaseable	UJ280		Brute Force Greaseable	UJ280
	Brute Force Non Greaseable	UJ269		Brute Force Non Greaseable	UJ269
	(For Aluminum Drive Shaft)	UJ369C		(For Aluminum Drive Shaft)	UJ369C
	U-Joint (Fr. Shaft; Rr.) [ⓑ]	UJ369		U-Joint (Fr. Shaft; Rr.) [ⓑ]	UJ437G
	Brute Force Greaseable	UJ280		Brute Force Greaseable	UJ240
	Brute Force Non Greaseable	UJ269		Brute Force Non Greaseable	UJ237
	(For Aluminum Drive Shaft)	UJ369C		Clamp Kit (Fr. Shaft; Rr.)	UJ437-10
	U-Joint (Rr. Shaft; Fr.) [ⓐ]	[2] UJ437G		U-Joint (Rr. Shaft; Fr.) [ⓐ]	[2] UJ437G
	Brute Force Greaseable	UJ240		Brute Force Greaseable	UJ240
	Brute Force Non Greaseable	UJ237		Brute Force Non Greaseable	UJ237
	Clamp Kit (Rr. Shaft; Fr.)	UJ437-10		Clamp Kit (Rr. Shaft; Fr.)	UJ437-10
	U-Joint (Rr. Shaft; Rr.) [ⓑ]	UJ437G		U-Joint (Rr. Shaft; Rr.) [ⓑ]	UJ437G
	Brute Force Greaseable	UJ240		Brute Force Greaseable	UJ240
	Brute Force Non Greaseable	UJ237		Brute Force Non Greaseable	UJ237
	Clamp Kit (Rr. Shaft; Rr.)	UJ437-10		Clamp Kit (Rr. Shaft; Rr.)	UJ437-10
	U-Joint (Front Axle Left Outer) [ⓐ]	UJ436		U-Joint (Front Axle Left Outer) [ⓐ]	UJ436
	Brute Force Greaseable	UJ466		Brute Force Greaseable	UJ466
	Brute Force Non Greaseable	UJ436		Brute Force Non Greaseable	UJ436
	U-Joint (Front Axle Right Inner) [ⓐ]	UJ436		U-Joint (Front Axle Right Inner) [ⓐ]	UJ436
	Brute Force Greaseable	UJ466		Brute Force Greaseable	UJ466
	Brute Force Non Greaseable	UJ436		Brute Force Non Greaseable	UJ436
	U-Joint (Front Axle Right Outer) [ⓑ]	UJ436		U-Joint (Front Axle Right Outer) [ⓑ]	UJ436
	Brute Force Greaseable	UJ466		Brute Force Greaseable	UJ466
	Brute Force Non Greaseable	UJ436		Brute Force Non Greaseable	UJ436

(Continued)

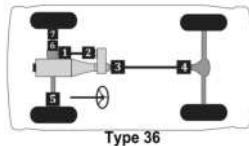

328 ▲ For Use w/ 1.063" Bearing Cap Application. ⓐ For Use w/ 1.188" Bearing Cap Application. ◇ For Use w/ Inner Lock Ring Application on Half Shaft. □ For Use w/ Outer Lock Ring Application on Half Shaft.

Passenger cars, light & medium trucks

(Cont.) -- Ford Truck Aerostar, Bronco II, Excursion, Expedition, Explorer (thru 2010), Explorer Sport Trac, Ranger

MFG./YEAR	MODEL & LOCATION	PART NO.	MFG./YEAR	MODEL & LOCATION	PART NO.
Drive Shaft (4 W/D) (Cont.)			Drive Shaft (4 W/D) (Cont.)		
U-Joint (Cont.)			U-Joint (Cont.)		
1984-1983 Ranger w/ 108" Wheel Base & Auto.			1984-1983 Ranger w/ 108" Wheel Base & 4 Spd.		
Trans.: [Type 36]			Man. Trans.: [Type 36]		
U-Joint (Fr. Shaft; Fr.) ^①		UJ369	U-Joint (Fr. Shaft; Fr.) ^①		UJ369
Brute Force Greaseable		UJ280	Brute Force Greaseable		UJ280
Brute Force Non Greaseable		UJ269	Brute Force Non Greaseable		UJ269
(For Aluminum Drive Shaft)		UJ369C	(For Aluminum Drive Shaft)		UJ369C
U-Joint (Fr. Shaft; Rr.) ^②		UJ369	U-Joint (Fr. Shaft; Rr.) ^②		UJ369
Brute Force Greaseable		UJ280	Brute Force Greaseable		UJ280
Brute Force Non Greaseable		UJ269	Brute Force Non Greaseable		UJ269
(For Aluminum Drive Shaft)		UJ369C	(For Aluminum Drive Shaft)		UJ369C
U-Joint (Rr. Shaft; Fr.) ^③	[2]	UJ437G	U-Joint (Rr. Shaft; Fr.) ^③	[2]	UJ437G
Brute Force Greaseable		UJ240	Brute Force Greaseable		UJ240
Brute Force Non Greaseable		UJ237	Brute Force Non Greaseable		UJ237
Clamp Kit (Rr. Shaft; Fr.)		UJ437-10	Clamp Kit (Rr. Shaft; Fr.)		UJ437-10
U-Joint (Rr. Shaft; Rr.) ^④		UJ437G	U-Joint (Rr. Shaft; Rr.) ^④		UJ437G
Brute Force Greaseable		UJ240	Brute Force Greaseable		UJ240
Brute Force Non Greaseable		UJ237	Brute Force Non Greaseable		UJ237
Clamp Kit (Rr. Shaft; Rr.)		UJ437-10	Clamp Kit (Rr. Shaft; Rr.)		UJ437-10
U-Joint (Front Axle Left Outer) ^⑤		UJ436	U-Joint (Front Axle Left Outer) ^⑤		UJ436
Brute Force Greaseable		UJ466	Brute Force Greaseable		UJ466
Brute Force Non Greaseable		UJ436	Brute Force Non Greaseable		UJ436
U-Joint (Front Axle Right Inner) ^⑥		UJ436	U-Joint (Front Axle Right Inner) ^⑥		UJ436
Brute Force Greaseable		UJ466	Brute Force Greaseable		UJ466
Brute Force Non Greaseable		UJ436	Brute Force Non Greaseable		UJ436
U-Joint (Front Axle Right Outer) ^⑦		UJ436	U-Joint (Front Axle Right Outer) ^⑦		UJ436
Brute Force Greaseable		UJ466	Brute Force Greaseable		UJ466
Brute Force Non Greaseable		UJ436	Brute Force Non Greaseable		UJ436

(Continued)

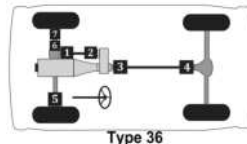

Passenger cars, light & medium trucks

Ford Truck Aerostar, Bronco II, Excursion, Expedition, Explorer (thru 2010), Explorer Sport Trac, Ranger -- (Cont.)

MFG./YEAR	MODEL & LOCATION	PART NO.	MFG./YEAR	MODEL & LOCATION	PART NO.
Drive Shaft (4 W/D) (Cont.)			Drive Shaft (4 W/D) (Cont.)		
U-Joint (Cont.)			U-Joint (Cont.)		
1984-1983 Ranger w/ 108" Wheel Base & 5 Spd.			1984-1983 Ranger w/ 114" Wheel Base & Auto.		
Man. Trans.: [Type 36]			Trans.: [Type 36]		
	U-Joint (Fr. Shaft; Frt.) ^①	UJ369		U-Joint (Fr. Shaft; Frt.) ^①	UJ369
	Brute Force Greaseable	UJ280		Brute Force Greaseable	UJ280
	Brute Force Non Greaseable	UJ269		Brute Force Non Greaseable	UJ269
	(For Aluminum Drive Shaft)	UJ369C		(For Aluminum Drive Shaft)	UJ369C
	U-Joint (Fr. Shaft; Rr.) ^②	UJ437G		U-Joint (Fr. Shaft; Rr.) ^②	UJ369
	Brute Force Greaseable	UJ240		Brute Force Greaseable	UJ280
	Brute Force Non Greaseable	UJ237		Brute Force Non Greaseable	UJ269
	Clamp Kit (Fr. Shaft; Rr.)	UJ437-10		(For Aluminum Drive Shaft)	UJ369C
	U-Joint (Rr. Shaft; Frt.) ^③	[2] UJ437G		U-Joint (Rr. Shaft; Frt.) ^③	UJ437G
	Brute Force Greaseable	UJ240		Brute Force Greaseable	UJ240
	Brute Force Non Greaseable	UJ237		Brute Force Non Greaseable	UJ237
	Clamp Kit (Rr. Shaft; Frt.)	UJ437-10		Clamp Kit (Rr. Shaft; Frt.)	UJ437-10
	U-Joint (Rr. Shaft; Rr.) ^④	UJ437G		U-Joint (Rr. Shaft; Rr.) ^④	UJ437G
	Brute Force Greaseable	UJ240		Brute Force Greaseable	UJ240
	Brute Force Non Greaseable	UJ237		Brute Force Non Greaseable	UJ237
	Clamp Kit (Rr. Shaft; Rr.)	UJ437-10		Clamp Kit (Rr. Shaft; Rr.)	UJ437-10
	U-Joint (Front Axle Left Outer) ^⑤	UJ436		U-Joint (Front Axle Left Outer) ^⑤	UJ436
	Brute Force Greaseable	UJ466		Brute Force Greaseable	UJ466
	Brute Force Non Greaseable	UJ436		Brute Force Non Greaseable	UJ436
	U-Joint (Front Axle Right Inner) ^⑥	UJ436		U-Joint (Front Axle Right Inner) ^⑥	UJ436
	Brute Force Greaseable	UJ466		Brute Force Greaseable	UJ466
	Brute Force Non Greaseable	UJ436		Brute Force Non Greaseable	UJ436
	U-Joint (Front Axle Right Outer) ^⑦	UJ436		U-Joint (Front Axle Right Outer) ^⑦	UJ436
	Brute Force Greaseable	UJ466		Brute Force Greaseable	UJ466
	Brute Force Non Greaseable	UJ436		Brute Force Non Greaseable	UJ436

(Continued)

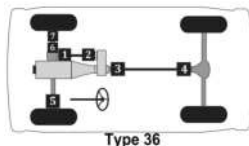

330 ▲ For Use w/ 1.063" Bearing Cap Application. ⊙ For Use w/ 1.188" Bearing Cap Application. ◇ For Use w/ Inner Lock Ring Application on Half Shaft. □ For Use w/ Outer Lock Ring Application on Half Shaft.

Passenger cars, light & medium trucks

(Cont.) -- Ford Truck Aerostar, Bronco II, Excursion, Expedition, Explorer (thru 2010), Explorer Sport Trac, Ranger

MFG./YEAR	MODEL & LOCATION	PART NO.	MFG./YEAR	MODEL & LOCATION	PART NO.
Drive Shaft (4 W/D) (Cont.)			Drive Shaft (4 W/D) (Cont.)		
U-Joint (Cont.)			U-Joint (Cont.)		
1984-1983 Ranger w/ 114" Wheel Base & 4 Spd.			1984-1983 Ranger w/ 114" Wheel Base & 5 Spd.		
Man. Trans.: [Type 36]			Man. Trans.: [Type 36]		
	U-Joint (Fr. Shaft; Fr.) ①	UJ369		U-Joint (Fr. Shaft; Fr.) ①	UJ369
	<i>Brute Force Greaseable</i>	UJ280		<i>Brute Force Greaseable</i>	UJ280
	<i>Brute Force Non Greaseable</i>	UJ269		<i>Brute Force Non Greaseable</i>	UJ269
	(For Aluminum Drive Shaft)	UJ369C		(For Aluminum Drive Shaft)	UJ369C
	U-Joint (Fr. Shaft; Rr.) ②	UJ369		U-Joint (Fr. Shaft; Rr.) ②	UJ437G
	<i>Brute Force Greaseable</i>	UJ280		<i>Brute Force Greaseable</i>	UJ240
	<i>Brute Force Non Greaseable</i>	UJ269		<i>Brute Force Non Greaseable</i>	UJ237
	(For Aluminum Drive Shaft)	UJ369C		Clamp Kit (Fr. Shaft; Rr.)	UJ437-10
	U-Joint (Rr. Shaft; Fr.) ③	UJ437G		U-Joint (Rr. Shaft; Fr.) ③	UJ437G
	<i>Brute Force Greaseable</i>	UJ240		<i>Brute Force Greaseable</i>	UJ240
	<i>Brute Force Non Greaseable</i>	UJ237		<i>Brute Force Non Greaseable</i>	UJ237
	Clamp Kit (Rr. Shaft; Fr.)	UJ437-10		Clamp Kit (Rr. Shaft; Fr.)	UJ437-10
	U-Joint (Rr. Shaft; Rr.) ④	UJ437G		U-Joint (Rr. Shaft; Rr.) ④	UJ437G
	<i>Brute Force Greaseable</i>	UJ240		<i>Brute Force Greaseable</i>	UJ240
	<i>Brute Force Non Greaseable</i>	UJ237		<i>Brute Force Non Greaseable</i>	UJ237
	Clamp Kit (Rr. Shaft; Rr.)	UJ437-10		Clamp Kit (Rr. Shaft; Rr.)	UJ437-10
	U-Joint (Front Axle Left Outer) ⑤	UJ436		U-Joint (Front Axle Left Outer) ⑤	UJ436
	<i>Brute Force Greaseable</i>	UJ466		<i>Brute Force Greaseable</i>	UJ466
	<i>Brute Force Non Greaseable</i>	UJ436		<i>Brute Force Non Greaseable</i>	UJ436
	U-Joint (Front Axle Right Inner) ⑥	UJ436		U-Joint (Front Axle Right Inner) ⑥	UJ436
	<i>Brute Force Greaseable</i>	UJ466		<i>Brute Force Greaseable</i>	UJ466
	<i>Brute Force Non Greaseable</i>	UJ436		<i>Brute Force Non Greaseable</i>	UJ436
	U-Joint (Front Axle Right Outer) ⑦	UJ436		U-Joint (Front Axle Right Outer) ⑦	UJ436
	<i>Brute Force Greaseable</i>	UJ466		<i>Brute Force Greaseable</i>	UJ466
	<i>Brute Force Non Greaseable</i>	UJ436		<i>Brute Force Non Greaseable</i>	UJ436

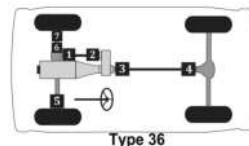

Passenger cars, light & medium trucks

Ford Truck Bronco

MFG./YEAR	MODEL & LOCATION	PART NO.	MFG./YEAR	MODEL & LOCATION	PART NO.
Drive Shaft (4 W/D)			Drive Shaft (4 W/D) (Cont.)		
U-Joint			U-Joint (Cont.)		
1996-1992 All: [Type 36]			1991 5.0L w/ 4 Spd. Auto. Trans.: [Type 36]		
	U-Joint (Fr. Shaft; Fr.) ⊙	UJ434		U-Joint (Fr. Shaft; Fr.) ⊙	UJ434
	<i>Brute Force Greaseable</i>	UJ265		<i>Brute Force Greaseable</i>	UJ265
	<i>Brute Force Non Greaseable</i>	UJ264		<i>Brute Force Non Greaseable</i>	UJ264
	U-Bolt Kit (Fr. Shaft; Fr.)	UJ534-10		U-Bolt Kit (Fr. Shaft; Fr.)	UJ534-10
	U-Joint (Fr. Shaft; Rr.) ⊙	UJ434		U-Joint (Fr. Shaft; Rr.) ⊙	UJ434
	<i>Brute Force Greaseable</i>	UJ265		<i>Brute Force Greaseable</i>	UJ265
	<i>Brute Force Non Greaseable</i>	UJ264		<i>Brute Force Non Greaseable</i>	UJ264
	U-Bolt Kit (Fr. Shaft; Rr.)	UJ534-10		U-Bolt Kit (Fr. Shaft; Rr.)	UJ534-10
	U-Joint (Rr. Shaft; Fr.) ⊙ [2]	UJ354		U-Joint (Rr. Shaft; Fr.) ⊙	UJ369
	<i>Brute Force Greaseable</i>	UJ270		<i>Brute Force Greaseable</i>	UJ280
	<i>Brute Force Non Greaseable</i>	UJ254		<i>Brute Force Non Greaseable</i>	UJ269
	(For Aluminum Drive Shaft)	UJ354C		(For Aluminum Drive Shaft)	UJ369C
	U-Joint (Rr. Shaft; Rr.) ⊙	UJ354		U-Joint (Rr. Shaft; Rr.) ⊙	UJ369
	<i>Brute Force Greaseable</i>	UJ270		<i>Brute Force Greaseable</i>	UJ280
	<i>Brute Force Non Greaseable</i>	UJ254		<i>Brute Force Non Greaseable</i>	UJ269
	(For Aluminum Drive Shaft)	UJ354C		(For Aluminum Drive Shaft)	UJ369C
	U-Joint (Front Axle Left Outer) ⊙	UJ371		U-Joint (Front Axle Left Outer) ⊙	UJ371
	<i>Brute Force Greaseable</i>	UJ377		<i>Brute Force Greaseable</i>	UJ377
	<i>Brute Force Non Greaseable</i>	UJ371		<i>Brute Force Non Greaseable</i>	UJ371
	U-Joint (Front Axle Right Inner) ⊙	UJ371		U-Joint (Front Axle Right Inner) ⊙	UJ371
	<i>Brute Force Greaseable</i>	UJ377		<i>Brute Force Greaseable</i>	UJ377
	<i>Brute Force Non Greaseable</i>	UJ371		<i>Brute Force Non Greaseable</i>	UJ371
	U-Joint (Front Axle Right Outer) ⊙	UJ371		U-Joint (Front Axle Right Outer) ⊙	UJ371
	<i>Brute Force Greaseable</i>	UJ377		<i>Brute Force Greaseable</i>	UJ377
	<i>Brute Force Non Greaseable</i>	UJ371		<i>Brute Force Non Greaseable</i>	UJ371
	Flange Yoke	UJ628F		<i>Brute Force Greaseable</i>	UJ377
	H Yoke	UJ648		<i>Brute Force Non Greaseable</i>	UJ371

(Continued)

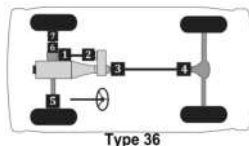

332 ▲ For Use w/ 1.063" Bearing Cap Application. ⊙ For Use w/ 1.188" Bearing Cap Application. ◇ For Use w/ Inner Lock Ring Application on Half Shaft. □ For Use w/ Outer Lock Ring Application on Half Shaft.

Passenger cars, light & medium trucks

(Cont.) -- Ford Truck Bronco

MFG./YEAR	MODEL & LOCATION	PART NO.	MFG./YEAR	MODEL & LOCATION	PART NO.
Drive Shaft (4 W/D) (Cont.)			Drive Shaft (4 W/D) (Cont.)		
U-Joint (Cont.)			U-Joint (Cont.)		
1991	Exc. 5.0L Eng. w/ 4 Spd. Auto. Trans.:		1990	All: [Type 36]	
	[Type 36]				
	U-Joint (Fr. Shaft; Fr.) ①	UJ434		U-Joint (Fr. Shaft; Fr.) ①	UJ434
	<i>Brute Force Greaseable</i>	UJ265		<i>Brute Force Greaseable</i>	UJ265
	<i>Brute Force Non Greaseable</i>	UJ264		<i>Brute Force Non Greaseable</i>	UJ264
	U-Bolt Kit (Fr. Shaft; Fr.)	UJ534-10		U-Joint (Fr. Shaft; Rr.) ②	UJ434
	U-Joint (Fr. Shaft; Rr.) ②	UJ434		<i>Brute Force Greaseable</i>	UJ265
	<i>Brute Force Greaseable</i>	UJ265		<i>Brute Force Non Greaseable</i>	UJ264
	<i>Brute Force Non Greaseable</i>	UJ264		U-Joint (Rr. Shaft; Fr.) ③	[2] UJ354
	U-Bolt Kit (Fr. Shaft; Rr.)	UJ534-10		<i>Brute Force Greaseable</i>	UJ270
	U-Joint (Rr. Shaft; Fr.) ③	[2] UJ354		<i>Brute Force Non Greaseable</i>	UJ254
	<i>Brute Force Greaseable</i>	UJ270		(For Aluminum Drive Shaft)	UJ354C
	<i>Brute Force Non Greaseable</i>	UJ254		U-Joint (Rr. Shaft; Rr.) ④	UJ354
	(For Aluminum Drive Shaft)	UJ354C		<i>Brute Force Greaseable</i>	UJ270
	U-Joint (Rr. Shaft; Rr.) ④	UJ354		<i>Brute Force Non Greaseable</i>	UJ254
	<i>Brute Force Greaseable</i>	UJ270		(For Aluminum Drive Shaft)	UJ354C
	<i>Brute Force Non Greaseable</i>	UJ254		U-Joint (Front Axle Left Outer) ⑤	UJ371
	(For Aluminum Drive Shaft)	UJ354C		<i>Brute Force Greaseable</i>	UJ377
	U-Joint (Front Axle Left Outer) ⑤	UJ371		<i>Brute Force Non Greaseable</i>	UJ371
	<i>Brute Force Greaseable</i>	UJ377		U-Joint (Front Axle Right Inner) ⑥	UJ371
	<i>Brute Force Non Greaseable</i>	UJ371		<i>Brute Force Greaseable</i>	UJ377
	U-Joint (Front Axle Right Inner) ⑥	UJ371		<i>Brute Force Non Greaseable</i>	UJ371
	<i>Brute Force Greaseable</i>	UJ377		U-Joint (Front Axle Right Outer) ⑦	UJ371
	<i>Brute Force Non Greaseable</i>	UJ371		<i>Brute Force Greaseable</i>	UJ377
	U-Joint (Front Axle Right Outer) ⑦	UJ371		<i>Brute Force Non Greaseable</i>	UJ371
	<i>Brute Force Greaseable</i>	UJ377		Centering Ball Kit	UJ612
	<i>Brute Force Non Greaseable</i>	UJ371		H Yoke	UJ648
	Flange Yoke	UJ628F			(Continued)
	H Yoke	UJ648			

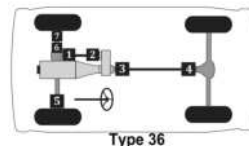

Passenger cars, light & medium trucks

Ford Truck Bronco -- (Cont.)

MFG./YEAR	MODEL & LOCATION	PART NO.	MFG./YEAR	MODEL & LOCATION	PART NO.
Drive Shaft (4 W/D) (Cont.)			Drive Shaft (4 W/D) (Cont.)		
U-Joint (Cont.)			U-Joint (Cont.)		
1989	5 Spd. Man. Trans. Thru 1/89: [Type 46]		1989	Exc. 5 Spd. Man. Trans. Thru 1/89: [Type 36]	
	U-Joint (Fr. Shaft; Frt.) ⓐ	UJ434		U-Joint (Fr. Shaft; Frt.) ⓐ	UJ434
	<i>Brute Force Greaseable</i>	UJ265		<i>Brute Force Greaseable</i>	UJ265
	<i>Brute Force Non Greaseable</i>	UJ264		<i>Brute Force Non Greaseable</i>	UJ264
	U-Bolt Kit (Fr. Shaft; Frt.)	UJ534-10		U-Bolt Kit (Fr. Shaft; Frt.)	UJ534-10
	U-Joint (Fr. Shaft; Ctr.) ⓐ	UJ534G		U-Joint (Fr. Shaft; Rr.) ⓐ	UJ434
	<i>Brute Force Greaseable</i>	UJ235		<i>Brute Force Greaseable</i>	UJ265
	<i>Brute Force Non Greaseable</i>	UJ234		<i>Brute Force Non Greaseable</i>	UJ264
	U-Joint (Fr. Shaft; Rr.) ⓐ	UJ355		U-Bolt Kit (Fr. Shaft; Rr.)	UJ534-10
	<i>Brute Force Greaseable</i>	UJ290		U-Joint (Rr. Shaft; Frt.) ⓐ	UJ354
	(For Aluminum Drive Shaft)	UJ355C		<i>Brute Force Greaseable</i>	UJ270
	U-Joint (Rr. Shaft; Frt.) ⓐ	UJ434		<i>Brute Force Non Greaseable</i>	UJ254
	<i>Brute Force Greaseable</i>	UJ265		(For Aluminum Drive Shaft)	UJ354C
	<i>Brute Force Non Greaseable</i>	UJ264		U-Joint (Rr. Shaft; Rr.) ⓐ	UJ434
	U-Bolt Kit (Rr. Shaft; Frt.)	UJ534-10		<i>Brute Force Greaseable</i>	UJ265
	U-Joint (Rr. Shaft; Ctr.) ⓐ	UJ434		<i>Brute Force Non Greaseable</i>	UJ264
	<i>Brute Force Greaseable</i>	UJ265		U-Bolt Kit (Rr. Shaft; Rr.)	UJ534-10
	<i>Brute Force Non Greaseable</i>	UJ264		U-Joint (Front Axle Left Outer) ⓐ	UJ371
	U-Bolt Kit (Rr. Shaft; Ctr.)	UJ534-10		<i>Brute Force Greaseable</i>	UJ377
	U-Joint (Rr. Shaft; Rr.) ⓐ	UJ434		<i>Brute Force Non Greaseable</i>	UJ371
	<i>Brute Force Greaseable</i>	UJ265		U-Joint (Front Axle Right Inner) ⓐ	UJ371
	<i>Brute Force Non Greaseable</i>	UJ264		<i>Brute Force Greaseable</i>	UJ377
	U-Bolt Kit (Rr. Shaft; Rr.)	UJ534-10		<i>Brute Force Non Greaseable</i>	UJ371
	U-Joint (Front Axle Left Outer) ⓐ	UJ371		U-Joint (Front Axle Right Outer) ⓐ	UJ371
	<i>Brute Force Greaseable</i>	UJ377		<i>Brute Force Greaseable</i>	UJ377
	<i>Brute Force Non Greaseable</i>	UJ371		<i>Brute Force Non Greaseable</i>	UJ371
	U-Joint (Front Axle Right Inner) ⓐ	UJ371			
	<i>Brute Force Greaseable</i>	UJ377			
	<i>Brute Force Non Greaseable</i>	UJ371			
	U-Joint (Front Axle Right Outer) ⓐ	UJ371			
	<i>Brute Force Greaseable</i>	UJ377			
	<i>Brute Force Non Greaseable</i>	UJ371			

(Continued)

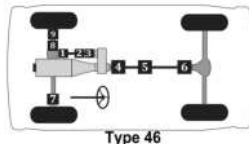
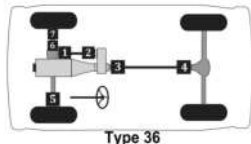

334 ▲ For Use w/ 1.063" Bearing Cap Application. ⓐ For Use w/ 1.188" Bearing Cap Application. ◇ For Use w/ Inner Lock Ring Application on Half Shaft. □ For Use w/ Outer Lock Ring Application on Half Shaft.

MFG./YEAR	MODEL & LOCATION	PART NO.	MFG./YEAR	MODEL & LOCATION	PART NO.
Drive Shaft (4 W/D) (Cont.)			Drive Shaft (4 W/D) (Cont.)		
U-Joint (Cont.)			U-Joint (Cont.)		
1989	5 Spd. Man. Trans. From 2/89: [Type 46]		1989	Exc. 5 Spd. Man. Trans. From 2/89: [Type 37]	
	U-Joint (Fr. Shaft; Frt.) ①	UJ434		U-Joint (Fr. Shaft; Frt.) ①	UJ434
	<i>Brute Force Greaseable</i>	UJ265		<i>Brute Force Greaseable</i>	UJ265
	<i>Brute Force Non Greaseable</i>	UJ264		<i>Brute Force Non Greaseable</i>	UJ264
	U-Bolt Kit (Fr. Shaft; Frt.)	UJ534-10		U-Bolt Kit (Fr. Shaft; Frt.)	UJ534-10
	U-Joint (Fr. Shaft; Ctr.) ②	UJ534G		U-Joint (Fr. Shaft; Rr.) ②	UJ434
	<i>Brute Force Greaseable</i>	UJ235		<i>Brute Force Greaseable</i>	UJ265
	<i>Brute Force Non Greaseable</i>	UJ234		<i>Brute Force Non Greaseable</i>	UJ264
	U-Joint (Fr. Shaft; Rr.) ③	UJ355		U-Bolt Kit (Fr. Shaft; Rr.)	UJ534-10
	<i>Brute Force Greaseable</i>	UJ290		U-Joint (Rr. Shaft; Frt.) ④	UJ354
	(For Aluminum Drive Shaft)	UJ355C		<i>Brute Force Greaseable</i>	UJ270
	U-Joint (Rr. Shaft; Frt.) ④	UJ354		<i>Brute Force Non Greaseable</i>	UJ254
	<i>Brute Force Greaseable</i>	UJ270		(For Aluminum Drive Shaft)	UJ354C
	<i>Brute Force Non Greaseable</i>	UJ254		U-Joint (Rr. Shaft; Ctr.) ⑤	UJ354
	(For Aluminum Drive Shaft)	UJ354C		<i>Brute Force Greaseable</i>	UJ270
	U-Joint (Rr. Shaft; Ctr.) ⑤	UJ354		<i>Brute Force Non Greaseable</i>	UJ254
	<i>Brute Force Greaseable</i>	UJ270		(For Aluminum Drive Shaft)	UJ354C
	<i>Brute Force Non Greaseable</i>	UJ254		U-Joint (Rr. Shaft; Rr.) ⑥	UJ354
	(For Aluminum Drive Shaft)	UJ354C		<i>Brute Force Greaseable</i>	UJ270
	U-Joint (Rr. Shaft; Rr.) ⑥	UJ354		<i>Brute Force Non Greaseable</i>	UJ254
	<i>Brute Force Greaseable</i>	UJ270		(For Aluminum Drive Shaft)	UJ354C
	<i>Brute Force Non Greaseable</i>	UJ254		U-Joint (Front Axle Left Outer) ⑦	UJ371
	(For Aluminum Drive Shaft)	UJ354C		<i>Brute Force Greaseable</i>	UJ377
	U-Joint (Front Axle Left Outer) ⑦	UJ371		<i>Brute Force Non Greaseable</i>	UJ371
	<i>Brute Force Greaseable</i>	UJ377		U-Joint (Front Axle Right Inner) ⑧	UJ371
	<i>Brute Force Non Greaseable</i>	UJ371		<i>Brute Force Greaseable</i>	UJ377
	U-Joint (Front Axle Right Inner) ⑧	UJ371		<i>Brute Force Non Greaseable</i>	UJ371
	<i>Brute Force Greaseable</i>	UJ377		U-Joint (Front Axle Right Outer) ⑨	UJ371
	<i>Brute Force Non Greaseable</i>	UJ371		<i>Brute Force Greaseable</i>	UJ377
	U-Joint (Front Axle Right Outer) ⑨	UJ371		<i>Brute Force Non Greaseable</i>	UJ371
	<i>Brute Force Greaseable</i>	UJ377		Centering Ball Kit	UJ612
	<i>Brute Force Non Greaseable</i>	UJ371		H Yoke	UJ648
	Centering Ball Kit	UJ612			(Continued)
	H Yoke	UJ648			

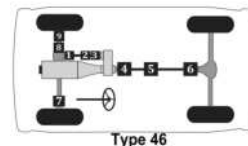
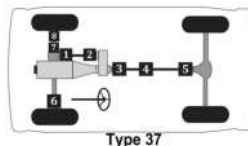

Passenger cars, light & medium trucks

Ford Truck Bronco -- (Cont.)

MFG./YEAR	MODEL & LOCATION	PART NO.	MFG./YEAR	MODEL & LOCATION	PART NO.
Drive Shaft (4 W/D) (Cont.)			Drive Shaft (4 W/D) (Cont.)		
U-Joint (Cont.)			U-Joint (Cont.)		
1988 w/ Auto. Trans.: [Type 36]			1988 w/ 4 Spd. Man. Trans.: [Type 36]		
	U-Joint (Fr. Shaft; Fr.) ^①	UJ434		U-Joint (Fr. Shaft; Fr.) ^①	UJ434
	Brute Force Greaseable	UJ265		Brute Force Greaseable	UJ265
	Brute Force Non Greaseable	UJ264		Brute Force Non Greaseable	UJ264
	U-Bolt Kit (Fr. Shaft; Fr.)	UJ534-10		U-Bolt Kit (Fr. Shaft; Fr.)	UJ534-10
	U-Joint (Fr. Shaft; Rr.) ^②	UJ434		U-Joint (Fr. Shaft; Rr.) ^②	UJ434
	Brute Force Greaseable	UJ265		Brute Force Greaseable	UJ265
	Brute Force Non Greaseable	UJ264		Brute Force Non Greaseable	UJ264
	U-Bolt Kit (Fr. Shaft; Rr.)	UJ534-10		U-Bolt Kit (Fr. Shaft; Rr.)	UJ534-10
	U-Joint (Rr. Shaft; Fr.) ^③	UJ354		U-Joint (Rr. Shaft; Fr.) ^③	UJ354
	Brute Force Greaseable	UJ270		Brute Force Greaseable	UJ270
	Brute Force Non Greaseable	UJ254		Brute Force Non Greaseable	UJ254
	(For Aluminum Drive Shaft)	UJ354C		(For Aluminum Drive Shaft)	UJ354C
	U-Joint (Rr. Shaft; Rr.) ^④	UJ434		U-Joint (Rr. Shaft; Rr.) ^④	UJ434
	Brute Force Greaseable	UJ265		Brute Force Greaseable	UJ265
	Brute Force Non Greaseable	UJ264		Brute Force Non Greaseable	UJ264
	U-Bolt Kit (Rr. Shaft; Rr.)	UJ534-10		U-Bolt Kit (Rr. Shaft; Rr.)	UJ534-10
	U-Joint (Front Axle Left Outer) ^⑤	UJ371		U-Joint (Front Axle Left Outer) ^⑤	UJ371
	Brute Force Greaseable	UJ377		Brute Force Greaseable	UJ377
	Brute Force Non Greaseable	UJ371		Brute Force Non Greaseable	UJ371
	U-Joint (Front Axle Right Inner) ^⑥	UJ371		U-Joint (Front Axle Right Inner) ^⑥	UJ371
	Brute Force Greaseable	UJ377		Brute Force Greaseable	UJ377
	Brute Force Non Greaseable	UJ371		Brute Force Non Greaseable	UJ371
	U-Joint (Front Axle Right Outer) ^⑦	UJ371		U-Joint (Front Axle Right Outer) ^⑦	UJ371
	Brute Force Greaseable	UJ377		Brute Force Greaseable	UJ377
	Brute Force Non Greaseable	UJ371		Brute Force Non Greaseable	UJ371

(Continued)

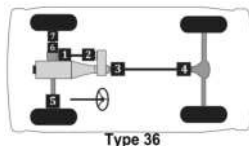

MFG./YEAR	MODEL & LOCATION	PART NO.	MFG./YEAR	MODEL & LOCATION	PART NO.
Drive Shaft (4 W/D) (Cont.)			Drive Shaft (4 W/D) (Cont.)		
U-Joint (Cont.)			U-Joint (Cont.)		
1988 w/ 5 Spd. Man. Trans.: [Type 37]			1987 w/ Inner Lock Rings: [Type 37]		
	U-Joint (Frnt. Shaft; Frt.) ^①	UJ434		U-Joint (Frnt. Shaft; Frt.) ^①	UJ434
	Brute Force Greaseable	UJ265		Brute Force Greaseable	UJ265
	Brute Force Non Greaseable	UJ264		Brute Force Non Greaseable	UJ264
	U-Bolt Kit (Frnt. Shaft; Frt.)	UJ534-10		U-Bolt Kit (Frnt. Shaft; Frt.)	UJ534-10
	U-Joint (Frnt. Shaft; Rr.) ^②	UJ434		U-Joint (Frnt. Shaft; Rr.) ^②	UJ354
	Brute Force Greaseable	UJ265		Brute Force Greaseable	UJ270
	Brute Force Non Greaseable	UJ264		Brute Force Non Greaseable	UJ254
	U-Bolt Kit (Frnt. Shaft; Rr.)	UJ534-10		(For Aluminum Drive Shaft)	UJ354C
	U-Joint (Rr. Shaft; Frt.) ^③	UJ434		U-Joint (Rr. Shaft; Frt.) ^③	UJ355
	Brute Force Greaseable	UJ265		Brute Force Greaseable	UJ290
	Brute Force Non Greaseable	UJ264		(For Aluminum Drive Shaft)	UJ355C
	U-Bolt Kit (Rr. Shaft; Frt.)	UJ534-10		U-Joint (Rr. Shaft; Ctr.) ^④	UJ534G
	U-Joint (Rr. Shaft; Ctr.) ^④	UJ434		Brute Force Greaseable	UJ235
	Brute Force Greaseable	UJ265		Brute Force Non Greaseable	UJ234
	Brute Force Non Greaseable	UJ264		U-Joint (Rr. Shaft; Rr.) ^⑤	UJ434
	U-Bolt Kit (Rr. Shaft; Ctr.)	UJ534-10		Brute Force Greaseable	UJ265
	U-Joint (Rr. Shaft; Rr.) ^⑤	UJ434		Brute Force Non Greaseable	UJ264
	Brute Force Greaseable	UJ265		U-Bolt Kit (Rr. Shaft; Rr.)	UJ534-10
	Brute Force Non Greaseable	UJ264		U-Joint (Front Axle Left Outer) ^⑥	UJ371
	U-Bolt Kit (Rr. Shaft; Rr.)	UJ534-10		Brute Force Greaseable	UJ377
	U-Joint (Front Axle Left Outer) ^⑥	UJ371		Brute Force Non Greaseable	UJ371
	Brute Force Greaseable	UJ377		U-Joint (Front Axle Right Inner) ^⑦	UJ371
	Brute Force Non Greaseable	UJ371		Brute Force Greaseable	UJ377
	U-Joint (Front Axle Right Inner) ^⑦	UJ371		Brute Force Non Greaseable	UJ371
	Brute Force Greaseable	UJ377		U-Joint (Front Axle Right Outer) ^⑧	UJ371
	Brute Force Non Greaseable	UJ371		Brute Force Greaseable	UJ377
	U-Joint (Front Axle Right Outer) ^⑧	UJ371		Brute Force Non Greaseable	UJ371
	Brute Force Greaseable	UJ377			
	Brute Force Non Greaseable	UJ371			

(Continued)

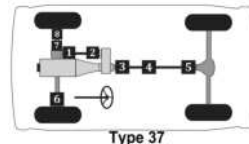

Passenger cars, light & medium trucks

Ford Truck Bronco -- (Cont.)

MFG./YEAR	MODEL & LOCATION	PART NO.	MFG./YEAR	MODEL & LOCATION	PART NO.
Drive Shaft (4 W/D) (Cont.)			Drive Shaft (4 W/D) (Cont.)		
U-Joint (Cont.)			U-Joint (Cont.)		
1987	w/ Outer Lock Rings: [Type 36]		1986	All: [Type 36]	
	U-Joint (Fr. Shaft; Fr.) [ⓐ]	UJ434		U-Joint (Fr. Shaft; Fr.) [ⓐ]	UJ434
	Brute Force Greaseable	UJ265		Brute Force Greaseable	UJ265
	Brute Force Non Greaseable	UJ264		Brute Force Non Greaseable	UJ264
	U-Bolt Kit (Fr. Shaft; Fr.)	UJ534-10		U-Bolt Kit (Fr. Shaft; Fr.)	UJ534-10
	U-Joint (Fr. Shaft; Rr.) [ⓑ]	UJ354		U-Joint (Fr. Shaft; Rr.) [ⓑ]	UJ354
	Brute Force Greaseable	UJ270		Brute Force Greaseable	UJ270
	Brute Force Non Greaseable	UJ254		Brute Force Non Greaseable	UJ254
	(For Aluminum Drive Shaft)	UJ354C		(For Aluminum Drive Shaft)	UJ354C
	U-Joint (Rr. Shaft; Fr.) [ⓑ]	[2] UJ354		U-Joint (Rr. Shaft; Fr.) [ⓑ]	[2] UJ354
	Brute Force Greaseable	UJ270		Brute Force Greaseable	UJ270
	Brute Force Non Greaseable	UJ254		Brute Force Non Greaseable	UJ254
	(For Aluminum Drive Shaft)	UJ354C		(For Aluminum Drive Shaft)	UJ354C
	U-Joint (Rr. Shaft; Rr.) [ⓑ]	UJ434		U-Joint (Rr. Shaft; Rr.) [ⓑ]	UJ434
	Brute Force Greaseable	UJ265		Brute Force Greaseable	UJ265
	Brute Force Non Greaseable	UJ264		Brute Force Non Greaseable	UJ264
	U-Bolt Kit (Rr. Shaft; Rr.)	UJ534-10		U-Bolt Kit (Rr. Shaft; Rr.)	UJ534-10
	U-Joint (Front Axle Left Outer) [ⓐ]	UJ371		U-Joint (Front Axle Left Outer) [ⓐ]	UJ371
	Brute Force Greaseable	UJ377		Brute Force Greaseable	UJ377
	Brute Force Non Greaseable	UJ371		Brute Force Non Greaseable	UJ371
	U-Joint (Front Axle Right Inner) [ⓐ]	UJ371		U-Joint (Front Axle Right Inner) [ⓐ]	UJ371
	Brute Force Greaseable	UJ377		Brute Force Greaseable	UJ377
	Brute Force Non Greaseable	UJ371		Brute Force Non Greaseable	UJ371
	U-Joint (Front Axle Right Outer) [ⓐ]	UJ371		U-Joint (Front Axle Right Outer) [ⓐ]	UJ371
	Brute Force Greaseable	UJ377		Brute Force Greaseable	UJ377
	Brute Force Non Greaseable	UJ371		Brute Force Non Greaseable	UJ371
	Centering Yoke	UJ608		Centering Yoke	UJ608
	Weld Yoke	UJ638		Weld Yoke	UJ638
	H Yoke	UJ648		H Yoke	UJ648
					(Continued)

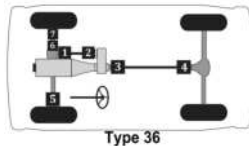

338 ▲ For Use w/ 1.063" Bearing Cap Application. ⓐ For Use w/ 1.188" Bearing Cap Application. ◇ For Use w/ Inner Lock Ring Application on Half Shaft. □ For Use w/ Outer Lock Ring Application on Half Shaft.

Passenger cars, light & medium trucks

(Cont.) -- Ford Truck Bronco

MFG./YEAR	MODEL & LOCATION	PART NO.	MFG./YEAR	MODEL & LOCATION	PART NO.
Drive Shaft (4 W/D) (Cont.)			Drive Shaft (4 W/D) (Cont.)		
U-Joint (Cont.)			U-Joint (Cont.)		
1985-1982 All: [Type 36]			1981-1980 From Ser. GJ0,001: [Type 36]		
	U-Joint (Frt. Shaft; Frt.) ^①	UJ434		U-Joint (Frt. Shaft; Frt.) ^①	UJ354
	Brute Force Greaseable	UJ265		Brute Force Greaseable	UJ270
	Brute Force Non Greaseable	UJ264		Brute Force Non Greaseable	UJ254
	U-Bolt Kit (Frt. Shaft; Frt.)	UJ534-10		(For Aluminum Drive Shaft)	UJ354C
	U-Joint (Frt. Shaft; Rr.) ^②	UJ434		U-Joint (Frt. Shaft; Rr.) ^②	UJ434
	Brute Force Greaseable	UJ265		Brute Force Greaseable	UJ265
	Brute Force Non Greaseable	UJ264		Brute Force Non Greaseable	UJ264
	U-Bolt Kit (Frt. Shaft; Rr.)	UJ534-10		U-Bolt Kit (Frt. Shaft; Rr.)	UJ534-10
	U-Joint (Rr. Shaft; Frt.) ^③	[2] UJ354		U-Joint (Rr. Shaft; Frt.) ^③	[2] UJ354
	Brute Force Greaseable	UJ270		Brute Force Greaseable	UJ270
	Brute Force Non Greaseable	UJ254		Brute Force Non Greaseable	UJ254
	(For Aluminum Drive Shaft)	UJ354C		(For Aluminum Drive Shaft)	UJ354C
	U-Joint (Rr. Shaft; Rr.) ^④	UJ434		U-Joint (Rr. Shaft; Rr.) ^④	UJ434
	Brute Force Greaseable	UJ265		Brute Force Greaseable	UJ265
	Brute Force Non Greaseable	UJ264		Brute Force Non Greaseable	UJ264
	U-Bolt Kit (Rr. Shaft; Rr.)	UJ534-10		U-Bolt Kit (Rr. Shaft; Rr.)	UJ534-10
	U-Joint (Front Axle Left Outer) ^⑤	UJ371		U-Joint (Front Axle Left Outer) ^⑤	UJ371
	Brute Force Greaseable	UJ377		Brute Force Greaseable	UJ377
	Brute Force Non Greaseable	UJ371		Brute Force Non Greaseable	UJ371
	U-Joint (Front Axle Right Inner) ^⑥	UJ371		U-Joint (Front Axle Right Inner) ^⑥	UJ371
	Brute Force Greaseable	UJ377		Brute Force Greaseable	UJ377
	Brute Force Non Greaseable	UJ371		Brute Force Non Greaseable	UJ371
	U-Joint (Front Axle Right Outer) ^⑦	UJ371		U-Joint (Front Axle Right Outer) ^⑦	UJ371
	Brute Force Greaseable	UJ377		Brute Force Greaseable	UJ377
	Brute Force Non Greaseable	UJ371		Brute Force Non Greaseable	UJ371
	Centering Yoke	UJ608		Centering Yoke	UJ608
	Weld Yoke	UJ638		Weld Yoke	UJ638
	H Yoke	UJ648		H Yoke	UJ648

(Continued)

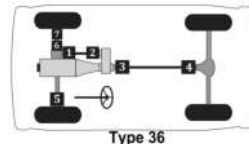

Passenger cars, light & medium trucks

Ford Truck Bronco -- (Cont.)

MFG./YEAR	MODEL & LOCATION	PART NO.	MFG./YEAR	MODEL & LOCATION	PART NO.
-----------	------------------	----------	-----------	------------------	----------

Drive Shaft (4 W/D) (Cont.)

U-Joint (Cont.)

1981-1980 Thru Ser. GJ0,000: [Type 36]

U-Joint (Fr. Shaft; Fr.) [⊙]	UJ434
Brute Force Greaseable	UJ265
Brute Force Non Greaseable	UJ264
U-Bolt Kit (Fr. Shaft; Fr.)	UJ534-10
U-Joint (Rr. Shaft; Rr.) [⊙]	UJ354
Brute Force Greaseable	UJ270
Brute Force Non Greaseable	UJ254
(For Aluminum Drive Shaft)	UJ354C
U-Joint (Rr. Shaft; Fr.) [⊙]	[2] UJ354
Brute Force Greaseable	UJ270
Brute Force Non Greaseable	UJ254
(For Aluminum Drive Shaft)	UJ354C
U-Joint (Rr. Shaft; Rr.) [⊙]	UJ434
Brute Force Greaseable	UJ265
Brute Force Non Greaseable	UJ264
U-Bolt Kit (Rr. Shaft; Rr.)	UJ534-10
U-Joint (Front Axle Left Outer) [⊙]	UJ371
Brute Force Greaseable	UJ377
Brute Force Non Greaseable	UJ371
U-Joint (Front Axle Right Inner) [⊙]	UJ371
Brute Force Greaseable	UJ377
Brute Force Non Greaseable	UJ371
U-Joint (Front Axle Right Outer) [⊙]	UJ371
Brute Force Greaseable	UJ377
Brute Force Non Greaseable	UJ371
Centering Yoke	UJ608
Weld Yoke	UJ638
H Yoke	UJ648

Drive Shaft (4 W/D) (Cont.)

U-Joint (Cont.)

1979 All: [Type 26]

U-Joint (Fr. Shaft; Fr.) [⊙]	UJ434
Brute Force Greaseable	UJ265
Brute Force Non Greaseable	UJ264
U-Bolt Kit (Fr. Shaft; Fr.)	UJ534-10
U-Joint (Fr. Shaft; Fr.) [⊙]	■ UJ354
Brute Force Greaseable	UJ270
Brute Force Non Greaseable	UJ254
(For Aluminum Drive Shaft)	UJ354C
U-Joint (Fr. Shaft; Rr.) [⊙]	[2] UJ354
Brute Force Greaseable	UJ270
Brute Force Non Greaseable	UJ254
(For Aluminum Drive Shaft)	UJ354C
U-Joint (Rr. Shaft; Fr.) [⊙]	[2] UJ354
Brute Force Greaseable	UJ270
Brute Force Non Greaseable	UJ254
(For Aluminum Drive Shaft)	UJ354C
U-Joint (Rr. Shaft; Rr.) [⊙]	UJ434
Brute Force Greaseable	UJ265
Brute Force Non Greaseable	UJ264
U-Bolt Kit (Rr. Shaft; Rr.)	UJ534-10
U-Joint (Wheel Joint) [⊙]	[2] UJ371
Brute Force Greaseable	UJ377
Brute Force Non Greaseable	UJ371
Centering Yoke	UJ608
Weld Yoke	UJ638
H Yoke	UJ648

1978 400 Eng. w/ Auto. Trans.: [Type 26]

U-Joint (Fr. Shaft; Fr.) [⊙]	UJ354
Brute Force Greaseable	UJ270
Brute Force Non Greaseable	UJ254
(For Aluminum Drive Shaft)	UJ354C
U-Joint (Fr. Shaft; Rr.) [⊙]	[2] UJ379
Brute Force Greaseable	UJ280
Brute Force Non Greaseable	UJ269
U-Joint (Rr. Shaft; Fr.) [⊙]	[2] UJ379
Brute Force Greaseable	UJ280
Brute Force Non Greaseable	UJ269
U-Joint (Rr. Shaft; Rr.) [⊙]	UJ354
Brute Force Greaseable	UJ270
Brute Force Non Greaseable	UJ254
(For Aluminum Drive Shaft)	UJ354C
U-Joint (Wheel Joint) [⊙]	[2] UJ371
Brute Force Greaseable	UJ377
Brute Force Non Greaseable	UJ371
Centering Yoke	UJ607
Weld Yoke	UJ633
H Yoke	UJ647

(Continued)

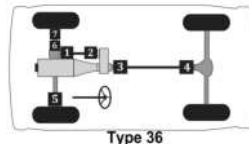
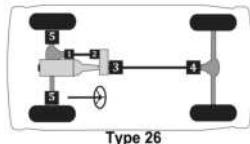

MFG./YEAR	MODEL & LOCATION	PART NO.	MFG./YEAR	MODEL & LOCATION	PART NO.
Drive Shaft (4 W/D) (Cont.)			Drive Shaft (4 W/D) (Cont.)		
U-Joint (Cont.)			U-Joint (Cont.)		
1978	Exc. 400 Eng. w/ Auto. Trans.: [Type 26]		1977-1970 All: [Type 26]		
	U-Joint (Frnt. Shaft; Frt.) ①	UJ369	U-Joint (Frnt. Shaft; Frt.) ①		UJ369
	Brute Force Greaseable	UJ280	Brute Force Greaseable		UJ280
	Brute Force Non Greaseable	UJ269	Brute Force Non Greaseable		UJ269
	(For Aluminum Drive Shaft)	UJ369C	(For Aluminum Drive Shaft)		UJ369C
	U-Bolt Kit (Frnt. Shaft; Frt.)	UJ329-10	U-Bolt Kit (Frnt. Shaft; Frt.)		UJ329-10
	U-Joint (Frnt. Shaft; Rr.) ②	[2] UJ379	U-Joint (Frnt. Shaft; Rr.) ②	[2]	UJ379
	Brute Force Greaseable	UJ280	Brute Force Greaseable		UJ280
	Brute Force Non Greaseable	UJ269	Brute Force Non Greaseable		UJ269
	U-Joint (Rr. Shaft; Frt.) ③	[2] UJ379	U-Joint (Rr. Shaft; Frt.) ③	[2]	UJ379
	Brute Force Greaseable	UJ280	Brute Force Greaseable		UJ280
	Brute Force Non Greaseable	UJ269	Brute Force Non Greaseable		UJ269
	U-Joint (Rr. Shaft; Rr.) ④	UJ369	U-Joint (Rr. Shaft; Rr.) ④		UJ369
	Brute Force Greaseable	UJ280	Brute Force Greaseable		UJ280
	Brute Force Non Greaseable	UJ269	Brute Force Non Greaseable		UJ269
	(For Aluminum Drive Shaft)	UJ369C	(For Aluminum Drive Shaft)		UJ369C
	U-Bolt Kit (Rr. Shaft; Rr.)	UJ329-10	U-Bolt Kit (Rr. Shaft; Rr.)		UJ329-10
	U-Joint (Wheel Joint) ⑤	[2] UJ371	U-Joint (Wheel Joint) ⑤	[2]	UJ365
	Brute Force Greaseable	UJ377	Brute Force Greaseable		UJ378
	Brute Force Non Greaseable	UJ371	Brute Force Non Greaseable		UJ365
	Centering Yoke	UJ607	Centering Yoke		UJ607
	Weld Yoke	UJ633	Weld Yoke		UJ633
	H Yoke	UJ647	H Yoke		UJ647
			1969-1966 All: [Type 32]		
	U-Joint (Frnt. Shaft; Frt.) ①	UJ497	U-Joint (Frnt. Shaft; Frt.) ①		UJ497
	U-Bolt Kit (Frnt. Shaft; Frt.)	UJ329-10	U-Bolt Kit (Frnt. Shaft; Frt.)		UJ329-10
	U-Joint (Frnt. Shaft; Ctr.) ②	UJ513	U-Joint (Frnt. Shaft; Ctr.) ②		UJ513
	U-Joint (Frnt. Shaft; Rr.) ③	UJ497	U-Joint (Frnt. Shaft; Rr.) ③		UJ497
	U-Bolt Kit (Frnt. Shaft; Rr.)	UJ329-10	U-Bolt Kit (Frnt. Shaft; Rr.)		UJ329-10
	U-Joint (Rr. Shaft; Frt.) ④	UJ497	U-Joint (Rr. Shaft; Frt.) ④		UJ497
	U-Bolt Kit (Rr. Shaft; Rr.)	UJ329-10	U-Bolt Kit (Rr. Shaft; Rr.)		UJ329-10
	U-Joint (Rr. Shaft; Ctr.) ⑤	UJ513	U-Joint (Rr. Shaft; Ctr.) ⑤		UJ513
	U-Joint (Rr. Shaft; Rr.) ⑥	UJ497	U-Joint (Rr. Shaft; Rr.) ⑥		UJ497
	U-Joint (Wheel Joint) ⑦	[2] UJ365	U-Joint (Wheel Joint) ⑦	[2]	UJ365
	Brute Force Greaseable	UJ378	Brute Force Greaseable		UJ378
	Brute Force Non Greaseable	UJ365	Brute Force Non Greaseable		UJ365

Ford Truck Courier

Drive Shaft (2 W/D)	
U-Joint	
1982-1972 2 Joint Shaft: [Type 1]	
U-Joint (Front) ①	UJ384
U-Joint (Rear) ②	UJ384
1982-1972 3 Joint Shaft: [Type 2]	
U-Joint (Front) ①	UJ384
U-Joint (Center) ②	UJ384
U-Joint (Rear) ③	UJ384

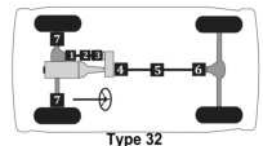
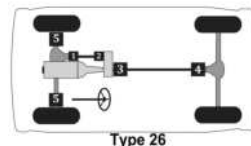
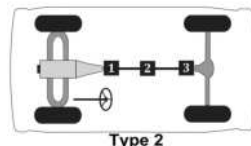
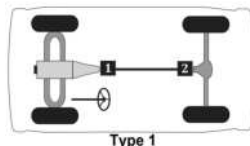

Passenger cars, light & medium trucks

Ford Truck Full size vans, 1/2 ton van, 3/4 ton van, 1 ton van

MFG./YEAR	MODEL & LOCATION	PART NO.	MFG./YEAR	MODEL & LOCATION	PART NO.
Drive Shaft			Drive Shaft (Cont.)		
U-Joint			U-Joint (Cont.)		
2022-2021 E-350 Super Duty w/ 2 Joint Shaft:			2019-2014 E-450 Super Duty w/ 2 Joint Shaft:		
[Type 1]			[Type 1]		
U-Joint (Front)Ⓛ		UJ331	U-Joint (Front)Ⓛ		UJ331
Brute Force Greaseable		UJ232	Brute Force Greaseable		UJ232
Brute Force Non Greaseable		UJ231	Brute Force Non Greaseable		UJ231
(For Aluminum Drive Shaft)		UJ331C	(For Aluminum Drive Shaft)		UJ331C
U-Joint (Rear)Ⓢ		UJ331	U-Joint (Rear)Ⓢ		UJ331
Brute Force Greaseable		UJ232	Brute Force Greaseable		UJ232
Brute Force Non Greaseable		UJ231	Brute Force Non Greaseable		UJ231
(For Aluminum Drive Shaft)		UJ331C	(For Aluminum Drive Shaft)		UJ331C
2020-2015 Transit w/ 3.622" Yoke: [Type 2]			2019-2014 E-450 Super Duty w/ 3 Joint Shaft:		
[Type 2]			[Type 2]		
U-Joint (Front)Ⓛ		UJ331	U-Joint (Front)Ⓛ		UJ331
Brute Force Greaseable		UJ232	Brute Force Greaseable		UJ232
Brute Force Non Greaseable		UJ231	Brute Force Non Greaseable		UJ231
(For Aluminum Drive Shaft)		UJ331C	(For Aluminum Drive Shaft)		UJ331C
U-Joint (Center)Ⓢ		UJ331	U-Joint (Center)Ⓢ		UJ330
Brute Force Greaseable		UJ232	Brute Force Greaseable		UJ295
Brute Force Non Greaseable		UJ231	(For Aluminum Drive Shaft)		UJ330C
(For Aluminum Drive Shaft)		UJ331C	U-Joint (Rear)Ⓢ		UJ330
U-Joint (Rear)Ⓢ		UJ331	Brute Force Greaseable		UJ295
Brute Force Greaseable		UJ232	Brute Force Non Greaseable		UJ231
Brute Force Non Greaseable		UJ231	(For Aluminum Drive Shaft)		UJ331C
(For Aluminum Drive Shaft)		UJ331C	2014-2011 E-350 Super Duty w/ 2 Joint Shaft, 8 Cyl. Eng. & 4 Spd. Trans.: [Type 1]		
2019-2015 Transit w/ 4.187" Yoke: [Type 2]			[Type 1]		
[Type 2]			U-Joint (Front)Ⓛ		
U-Joint (Front)Ⓛ		UJ330	Brute Force Greaseable		UJ232
Brute Force Greaseable		UJ295	Brute Force Non Greaseable		UJ231
(For Aluminum Drive Shaft)		UJ330C	(For Aluminum Drive Shaft)		UJ331C
U-Joint (Center)Ⓢ		UJ330	U-Joint (Rear)Ⓢ		UJ331
Brute Force Greaseable		UJ295	Brute Force Greaseable		UJ232
(For Aluminum Drive Shaft)		UJ330C	Brute Force Non Greaseable		UJ231
U-Joint (Rear)Ⓢ		UJ330	(For Aluminum Drive Shaft)		UJ331C
Brute Force Greaseable		UJ295	2014-2011 E-350 Super Duty w/ 2 Joint Shaft, 8 Cyl. Eng. & 5 Spd. Trans.: [Type 1]		
(For Aluminum Drive Shaft)		UJ330C	[Type 1]		
2019-2015 E-350 Super Duty w/ 2 Joint Shaft:			U-Joint (Front)Ⓛ		
[Type 1]			Brute Force Greaseable		
[Type 1]			[Type 1]		
U-Joint (Front)Ⓛ		UJ331	(For Aluminum Drive Shaft)		UJ330C
Brute Force Greaseable		UJ232	U-Joint (Rear)Ⓢ		UJ330
Brute Force Non Greaseable		UJ231	Brute Force Greaseable		UJ295
(For Aluminum Drive Shaft)		UJ331C	(For Aluminum Drive Shaft)		UJ330C
U-Joint (Rear)Ⓢ		UJ331	2014-2011 E-350 Super Duty w/ 2 Joint Shaft & 10 Cyl. Eng.: [Type 1]		
Brute Force Greaseable		UJ232	[Type 1]		
Brute Force Non Greaseable		UJ231	U-Joint (Front)Ⓛ		
(For Aluminum Drive Shaft)		UJ331C	Brute Force Greaseable		
2019-2015 E-350 Super Duty w/ 3 Joint Shaft:			[Type 1]		
[Type 2]			[Type 1]		
[Type 2]			U-Joint (Rear)Ⓢ		
U-Joint (Front)Ⓛ		UJ330	Brute Force Greaseable		UJ295
Brute Force Greaseable		UJ295	(For Aluminum Drive Shaft)		UJ330C
(For Aluminum Drive Shaft)		UJ330C	U-Joint (Rear)Ⓢ		UJ330
U-Joint (Center)Ⓢ		UJ330	Brute Force Greaseable		UJ295
Brute Force Greaseable		UJ295	(For Aluminum Drive Shaft)		UJ330C
(For Aluminum Drive Shaft)		UJ330C	(Continued)		
U-Joint (Rear)Ⓢ		UJ330			
Brute Force Greaseable		UJ295			
(For Aluminum Drive Shaft)		UJ330C			

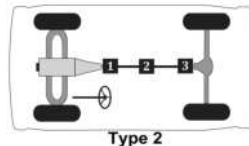
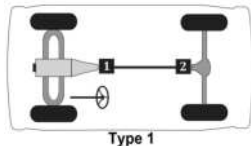

Passenger cars, light & medium trucks

(Cont.) -- Ford Truck Full size vans, 1/2 ton van, 3/4 ton van, 1 ton van

MFG./YEAR	MODEL & LOCATION	PART NO.	MFG./YEAR	MODEL & LOCATION	PART NO.
Drive Shaft (Cont.)			Drive Shaft (Cont.)		
U-Joint (Cont.)			U-Joint (Cont.)		
2014-2011 E-350 Super Duty w/ 3 Joint Shaft, 8 Cyl. Eng. & 4 Spd. Trans.: [Type 2]			2014-1997 E-250 & E-250 Super Duty: [Type 1]		
	U-Joint (Front)⓪	UJ331		U-Joint (Front)⓪	UJ331
	<i>Brute Force Greaseable</i>	UJ232		<i>Brute Force Greaseable</i>	UJ232
	<i>Brute Force Non Greaseable</i>	UJ231		<i>Brute Force Non Greaseable</i>	UJ231
	(For Aluminum Drive Shaft)	UJ331C		(For Aluminum Drive Shaft)	UJ331C
	U-Joint (Center)⓪	UJ331		U-Joint (Rear)⓪	UJ331
	<i>Brute Force Greaseable</i>	UJ232		<i>Brute Force Greaseable</i>	UJ232
	<i>Brute Force Non Greaseable</i>	UJ231		<i>Brute Force Non Greaseable</i>	UJ231
	(For Aluminum Drive Shaft)	UJ331C		(For Aluminum Drive Shaft)	UJ331C
	U-Joint (Rear)⓪	UJ331		2013-2005 E-450: [Type 2]	
	<i>Brute Force Greaseable</i>	UJ232		U-Joint (Front)⓪	UJ330
	<i>Brute Force Non Greaseable</i>	UJ231		<i>Brute Force Greaseable</i>	UJ295
	(For Aluminum Drive Shaft)	UJ331C		(For Aluminum Drive Shaft)	UJ330C
	2014-2011 E-350 Super Duty w/ 3 Joint Shaft, 8 Cyl. Eng. & 5 Spd. Trans.: [Type 2]			Clamp Kit (Front)	UJ331-10
	U-Joint (Front)⓪	UJ330		U-Joint (Center)⓪	UJ330
	<i>Brute Force Greaseable</i>	UJ295		<i>Brute Force Greaseable</i>	UJ295
	(For Aluminum Drive Shaft)	UJ330C		(For Aluminum Drive Shaft)	UJ330C
	U-Joint (Center)⓪	UJ330		Clamp Kit (Center)	UJ331-10
	<i>Brute Force Greaseable</i>	UJ295		U-Joint (Rear)⓪	UJ330
	(For Aluminum Drive Shaft)	UJ330C		<i>Brute Force Greaseable</i>	UJ295
	U-Joint (Rear)⓪	UJ330		(For Aluminum Drive Shaft)	UJ330C
	<i>Brute Force Greaseable</i>	UJ295		Clamp Kit (Rear)	UJ331-10
	(For Aluminum Drive Shaft)	UJ330C		2010-2005 E-350 Super Duty w/ 2 Joint Shaft & Diesel Eng.: [Type 1]	
	2014-2011 E-350 Super Duty w/ 3 Joint Shaft & 10 Cyl. Eng.: [Type 2]			U-Joint (Front)⓪	UJ330
	U-Joint (Front)⓪	UJ330		<i>Brute Force Greaseable</i>	UJ295
	<i>Brute Force Greaseable</i>	UJ295		(For Aluminum Drive Shaft)	UJ330C
	(For Aluminum Drive Shaft)	UJ330C		Clamp Kit (Front)	UJ331-10
	U-Joint (Center)⓪	UJ330		U-Joint (Rear)⓪	UJ330
	<i>Brute Force Greaseable</i>	UJ295		<i>Brute Force Greaseable</i>	UJ295
	(For Aluminum Drive Shaft)	UJ330C		(For Aluminum Drive Shaft)	UJ330C
	U-Joint (Rear)⓪	UJ330		Clamp Kit (Rear)	UJ331-10
	<i>Brute Force Greaseable</i>	UJ295		2010-2005 E-350 Super Duty w/ 2 Joint Shaft & Gas Eng.: [Type 1]	
	(For Aluminum Drive Shaft)	UJ330C		U-Joint (Front)⓪	UJ331
	2014-2007 Transit:			<i>Brute Force Greaseable</i>	UJ232
	Flex Coupler	VKJF98021		<i>Brute Force Non Greaseable</i>	UJ231
	(For Aluminum Drive Shaft)	UJ330C		(For Aluminum Drive Shaft)	UJ331C
	2014-1997 E-150 & E-150 Club Wagon: [Type 1]			U-Joint (Rear)⓪	UJ331
	U-Joint (Front)⓪	UJ331		<i>Brute Force Greaseable</i>	UJ232
	<i>Brute Force Greaseable</i>	UJ232		<i>Brute Force Non Greaseable</i>	UJ231
	<i>Brute Force Non Greaseable</i>	UJ231		(For Aluminum Drive Shaft)	UJ331C
	(For Aluminum Drive Shaft)	UJ331C			
	U-Joint (Rear)⓪	UJ331			
	<i>Brute Force Greaseable</i>	UJ232			
	<i>Brute Force Non Greaseable</i>	UJ231			
	(For Aluminum Drive Shaft)	UJ331C			

(Continued)

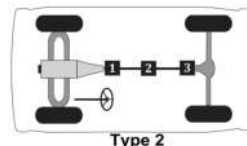
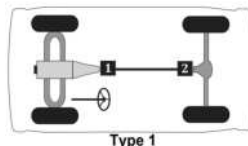

Passenger cars, light & medium trucks

Ford Truck Full size vans, 1/2 ton van, 3/4 ton van, 1 ton van -- (Cont.)

MFG./YEAR	MODEL & LOCATION	PART NO.	MFG./YEAR	MODEL & LOCATION	PART NO.
Drive Shaft (Cont.)			Drive Shaft (Cont.)		
U-Joint (Cont.)			U-Joint (Cont.)		
2010-2005 E-350 Super Duty w/ 3 Joint Shaft:			2004-2002 E-450 w/ 4.125" Yoke: [Type 2]		
[Type 2]					
	U-Joint (Front)Ⓛ	UJ330		U-Joint (Front)Ⓛ	UJ331
	<i>Brute Force Greaseable</i>	UJ295		<i>Brute Force Greaseable</i>	UJ232
	(For Aluminum Drive Shaft)	UJ330C		<i>Brute Force Non Greaseable</i>	UJ231
	Clamp Kit (Front)	UJ331-10		(For Aluminum Drive Shaft)	UJ331C
	U-Joint (Center)Ⓢ	UJ330		Clamp Kit (Front)	UJ331-10
	<i>Brute Force Greaseable</i>	UJ295		U-Joint (Center)Ⓢ	UJ331
	(For Aluminum Drive Shaft)	UJ330C		<i>Brute Force Greaseable</i>	UJ232
	Clamp Kit (Center)	UJ331-10		<i>Brute Force Non Greaseable</i>	UJ231
	U-Joint (Rear)Ⓢ	UJ330		(For Aluminum Drive Shaft)	UJ331C
	<i>Brute Force Greaseable</i>	UJ295		Clamp Kit (Center)	UJ331-10
	(For Aluminum Drive Shaft)	UJ330C		U-Joint (Rear)Ⓢ	UJ331
	Clamp Kit (Rear)	UJ331-10		<i>Brute Force Greaseable</i>	UJ232
	2004 E-350 Super Duty w/ 2 Joint Shaft & 4 Spd. Trans.: [Type 1]			<i>Brute Force Non Greaseable</i>	UJ231
	U-Joint (Front)Ⓛ	UJ331		(For Aluminum Drive Shaft)	UJ331C
	<i>Brute Force Greaseable</i>	UJ232		Clamp Kit (Rear)	UJ331-10
	<i>Brute Force Non Greaseable</i>	UJ231		2004-2002 E-450 w/ 4.875" Yoke: [Type 2]	
	(For Aluminum Drive Shaft)	UJ331C		U-Joint (Front)Ⓛ	UJ330
	U-Joint (Rear)Ⓢ	UJ331		<i>Brute Force Greaseable</i>	UJ295
	<i>Brute Force Greaseable</i>	UJ232		(For Aluminum Drive Shaft)	UJ330C
	<i>Brute Force Non Greaseable</i>	UJ231		Clamp Kit (Front)	UJ331-10
	(For Aluminum Drive Shaft)	UJ331C		U-Joint (Center)Ⓢ	UJ330
	2004 E-350 Super Duty w/ 2 Joint Shaft & 5 Spd. Trans.: [Type 1]			<i>Brute Force Greaseable</i>	UJ295
	U-Joint (Front)Ⓛ	UJ330		(For Aluminum Drive Shaft)	UJ330C
	<i>Brute Force Greaseable</i>	UJ295		Clamp Kit (Rear)	UJ331-10
	(For Aluminum Drive Shaft)	UJ330C		2003-2002 E-550 w/ 3 Joint Shaft: [Type 2]	
	Clamp Kit (Front)	UJ331-10		U-Joint (Front)Ⓛ	UJ351
	U-Joint (Rear)Ⓢ	UJ330		(For Aluminum Drive Shaft)	UJ351C
	<i>Brute Force Greaseable</i>	UJ295		<i>Brute Force Non Greaseable</i>	UJ351BF
	(For Aluminum Drive Shaft)	UJ330C		Clamp Kit (Front)	UJ351-10
	Clamp Kit (Rear)	UJ331-10		U-Joint (Center)Ⓢ	UJ351
	2004 E-350 Super Duty w/ 3 Joint Shaft:			(For Aluminum Drive Shaft)	UJ351C
	[Type 2]			<i>Brute Force Non Greaseable</i>	UJ351BF
	U-Joint (Front)Ⓛ	UJ331		Clamp Kit (Center)	UJ351-10
	<i>Brute Force Greaseable</i>	UJ232		U-Joint (Rear)Ⓢ	UJ351
	<i>Brute Force Non Greaseable</i>	UJ231		(For Aluminum Drive Shaft)	UJ351C
	(For Aluminum Drive Shaft)	UJ331C		<i>Brute Force Non Greaseable</i>	UJ351BF
	U-Joint (Center)Ⓢ	UJ331		Clamp Kit (Rear)	UJ351-10
	<i>Brute Force Greaseable</i>	UJ232			
	<i>Brute Force Non Greaseable</i>	UJ231			
	(For Aluminum Drive Shaft)	UJ331C			
	U-Joint (Rear)Ⓢ	UJ331			
	<i>Brute Force Greaseable</i>	UJ232			
	<i>Brute Force Non Greaseable</i>	UJ231			
	(For Aluminum Drive Shaft)	UJ331C			

(Continued)

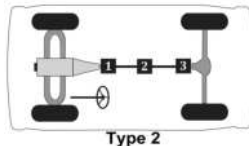
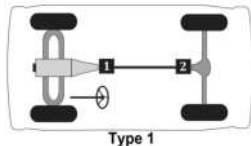

Passenger cars, light & medium trucks

(Cont.) -- Ford Truck Full size vans, 1/2 ton van, 3/4 ton van, 1 ton van

MFG./YEAR	MODEL & LOCATION	PART NO.	MFG./YEAR	MODEL & LOCATION	PART NO.
Drive Shaft (Cont.)			Drive Shaft (Cont.)		
U-Joint (Cont.)			U-Joint (Cont.)		
2003-2002 E-550 w/ 4 Joint Shaft: [Type 3]			1999-1996 E (Super Duty) w/ 3 Joint Shaft:		
			[Type 2]		
U-Joint (Front)⓪		UJ351	U-Joint (Front)⓪		UJ330
(For Aluminum Drive Shaft)		UJ351C	Brute Force Greaseable		UJ295
Brute Force Non Greaseable		UJ351BF	(For Aluminum Drive Shaft)		UJ330C
Clamp Kit (Front)		UJ351-10	Clamp Kit (Front)		UJ331-10
U-Joint (Center; Front)⓪		UJ351	U-Joint (Center)⓪		UJ330
(For Aluminum Drive Shaft)		UJ351C	Brute Force Greaseable		UJ295
Brute Force Non Greaseable		UJ351BF	(For Aluminum Drive Shaft)		UJ330C
Clamp Kit (Center; Front)		UJ351-10	Clamp Kit (Center)		UJ331-10
U-Joint (Center; Rear)⓪		UJ351	U-Joint (Rear)⓪		UJ330
(For Aluminum Drive Shaft)		UJ351C	Brute Force Greaseable		UJ295
Brute Force Non Greaseable		UJ351BF	(For Aluminum Drive Shaft)		UJ330C
Clamp Kit (Center; Rear)		UJ351-10	Clamp Kit (Rear)		UJ331-10
U-Joint (Rear)⓪		UJ351	1996-1995 E-350 & E-350 Club Wagon w/ 2 Joint		
(For Aluminum Drive Shaft)		UJ351C	Shaft, 1.063" Dia. Brg. Cap & 5.8L		
Brute Force Non Greaseable		UJ351BF	Eng.: [Type 1]		
Clamp Kit (Rear)		UJ351-10	U-Joint (Front)⓪		UJ354
2003-1997 E-350 & E-350 Club Wagon w/ 2 Joint			Brute Force Greaseable		UJ270
Shaft: [Type 1]			Brute Force Non Greaseable		UJ254
U-Joint (Front)⓪		UJ331	(For Aluminum Drive Shaft)		UJ354C
Brute Force Greaseable		UJ232	U-Joint (Rear)⓪		UJ434
Brute Force Non Greaseable		UJ231	Brute Force Greaseable		UJ265
(For Aluminum Drive Shaft)		UJ331C	Brute Force Non Greaseable		UJ264
U-Joint (Rear)⓪		UJ331	U-Bolt Kit (Rear)		UJ534-10
Brute Force Greaseable		UJ232	1996-1995 E-350 & E-350 Club Wagon w/ 2 Joint		
Brute Force Non Greaseable		UJ231	Shaft, 1.188" Dia. Brg. Cap & 5.8L		
(For Aluminum Drive Shaft)		UJ331C	Eng.: [Type 1]		
2003-1997 E-350 & E-350 Club Wagon w/ 3 Joint			U-Joint (Front)⓪		UJ331
Shaft: [Type 2]			Brute Force Greaseable		UJ232
U-Joint (Front)⓪		UJ331	Brute Force Non Greaseable		UJ231
Brute Force Greaseable		UJ232	(For Aluminum Drive Shaft)		UJ331C
Brute Force Non Greaseable		UJ231	Clamp Kit (Front)		UJ331-10
(For Aluminum Drive Shaft)		UJ331C	U-Joint (Rear)⓪		UJ331
U-Joint (Center)⓪		UJ331	Brute Force Greaseable		UJ232
Brute Force Greaseable		UJ232	Brute Force Non Greaseable		UJ231
Brute Force Non Greaseable		UJ231	(For Aluminum Drive Shaft)		UJ331C
(For Aluminum Drive Shaft)		UJ331C	Clamp Kit (Rear)		UJ331-10
U-Joint (Rear)⓪		UJ331	(Continued)		
Brute Force Greaseable		UJ232			
Brute Force Non Greaseable		UJ231			
(For Aluminum Drive Shaft)		UJ331C			
1999-1996 E (Super Duty) w/ 2 Joint Shaft:					
[Type 1]					
U-Joint (Front)⓪		UJ330			
Brute Force Greaseable		UJ295			
(For Aluminum Drive Shaft)		UJ330C			
Clamp Kit (Front)		UJ331-10			
U-Joint (Rear)⓪		UJ330			
Brute Force Greaseable		UJ295			
(For Aluminum Drive Shaft)		UJ330C			
Clamp Kit (Rear)		UJ331-10			

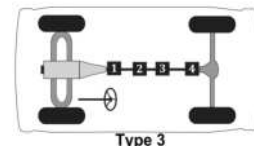
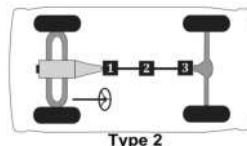
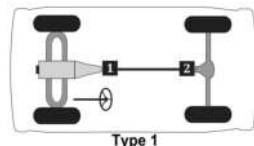

Passenger cars, light & medium trucks

Ford Truck Full size vans, 1/2 ton van, 3/4 ton van, 1 ton van -- (Cont.)

MFG./YEAR	MODEL & LOCATION	PART NO.	MFG./YEAR	MODEL & LOCATION	PART NO.
-----------	------------------	----------	-----------	------------------	----------

Drive Shaft (Cont.)

U-Joint (Cont.)

1996-1995 E-350 & E-350 Club Wagon w/ 3 Joint
Shaft, 1.063" Dia. Brg. Cap & 5.8L
Eng.: [Type 2]

U-Joint (Front)Ⓚ	UJ354
<i>Brute Force Greaseable</i>	<i>UJ270</i>
<i>Brute Force Non Greaseable</i>	<i>UJ254</i>
(For Aluminum Drive Shaft)	UJ354C
U-Joint (Center)Ⓛ	UJ354
<i>Brute Force Greaseable</i>	<i>UJ270</i>
<i>Brute Force Non Greaseable</i>	<i>UJ254</i>
(For Aluminum Drive Shaft)	UJ354C
U-Joint (Rear)Ⓛ	UJ434
<i>Brute Force Greaseable</i>	<i>UJ265</i>
<i>Brute Force Non Greaseable</i>	<i>UJ264</i>
U-Bolt Kit (Rear)	UJ534-10

1996-1995 E-350 & E-350 Club Wagon w/ 3 Joint
Shaft, 1.188" Dia. Brg. Cap & 5.8L
Eng.: [Type 2]

U-Joint (Front)Ⓚ	UJ331
<i>Brute Force Greaseable</i>	<i>UJ232</i>
<i>Brute Force Non Greaseable</i>	<i>UJ231</i>
(For Aluminum Drive Shaft)	UJ331C
Clamp Kit (Front)	UJ331-10
U-Joint (Center)Ⓛ	UJ331
<i>Brute Force Greaseable</i>	<i>UJ232</i>
<i>Brute Force Non Greaseable</i>	<i>UJ231</i>
(For Aluminum Drive Shaft)	UJ331C
Clamp Kit (Center)	UJ331-10
U-Joint (Rear)Ⓛ	UJ331
<i>Brute Force Greaseable</i>	<i>UJ232</i>
<i>Brute Force Non Greaseable</i>	<i>UJ231</i>
(For Aluminum Drive Shaft)	UJ331C
Clamp Kit (Rear)	UJ331-10

1996-1993 E-350 & E-350 Club Wagon w/ 2 Joint
Shaft & 4.9L Eng.: [Type 1]

U-Joint (Front)Ⓚ	UJ354
<i>Brute Force Greaseable</i>	<i>UJ270</i>
<i>Brute Force Non Greaseable</i>	<i>UJ254</i>
(For Aluminum Drive Shaft)	UJ354C
U-Joint (Rear)Ⓛ	UJ354
<i>Brute Force Greaseable</i>	<i>UJ270</i>
<i>Brute Force Non Greaseable</i>	<i>UJ254</i>
(For Aluminum Drive Shaft)	UJ354C

Drive Shaft (Cont.)

U-Joint (Cont.)

1996-1993 E-350 & E-350 Club Wagon w/ 3 Joint
Shaft & 4.9L Eng.: [Type 2]

U-Joint (Front)Ⓚ	UJ354
<i>Brute Force Greaseable</i>	<i>UJ270</i>
<i>Brute Force Non Greaseable</i>	<i>UJ254</i>
(For Aluminum Drive Shaft)	UJ354C
U-Joint (Center)Ⓛ	UJ354
<i>Brute Force Greaseable</i>	<i>UJ270</i>
<i>Brute Force Non Greaseable</i>	<i>UJ254</i>
(For Aluminum Drive Shaft)	UJ354C
U-Joint (Rear)Ⓛ	UJ434
<i>Brute Force Greaseable</i>	<i>UJ265</i>
<i>Brute Force Non Greaseable</i>	<i>UJ264</i>
U-Bolt Kit (Rear)	UJ534-10

1996-1993 E-350 & E-350 Club Wagon w/ 2 Joint
Shaft, 7.3L & 7.5L Eng.s.: [Type 1]

U-Joint (Front)Ⓚ	UJ331
<i>Brute Force Greaseable</i>	<i>UJ232</i>
<i>Brute Force Non Greaseable</i>	<i>UJ231</i>
(For Aluminum Drive Shaft)	UJ331C
Clamp Kit (Front)	UJ331-10
U-Joint (Rear)Ⓛ	UJ331
<i>Brute Force Greaseable</i>	<i>UJ232</i>
<i>Brute Force Non Greaseable</i>	<i>UJ231</i>
(For Aluminum Drive Shaft)	UJ331C
Clamp Kit (Rear)	UJ331-10

1996-1993 E-350 & E-350 Club Wagon w/ 3 Joint
Shaft, 7.3L & 7.5L Eng.s.: [Type 2]

U-Joint (Front)Ⓚ	UJ331
<i>Brute Force Greaseable</i>	<i>UJ232</i>
<i>Brute Force Non Greaseable</i>	<i>UJ231</i>
(For Aluminum Drive Shaft)	UJ331C
Clamp Kit (Front)	UJ331-10
U-Joint (Center)Ⓛ	UJ331
<i>Brute Force Greaseable</i>	<i>UJ232</i>
<i>Brute Force Non Greaseable</i>	<i>UJ231</i>
(For Aluminum Drive Shaft)	UJ331C
Clamp Kit (Center)	UJ331-10
U-Joint (Rear)Ⓛ	UJ331
<i>Brute Force Greaseable</i>	<i>UJ232</i>
<i>Brute Force Non Greaseable</i>	<i>UJ231</i>
(For Aluminum Drive Shaft)	UJ331C
Clamp Kit (Rear)	UJ331-10

(Continued)

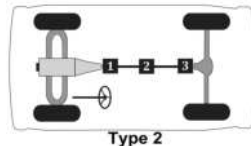
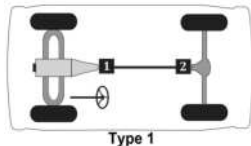

Passenger cars, light & medium trucks

(Cont.) -- Ford Truck Full size vans, 1/2 ton van, 3/4 ton van, 1 ton van

MFG./YEAR	MODEL & LOCATION	PART NO.	MFG./YEAR	MODEL & LOCATION	PART NO.
Drive Shaft (Cont.)			Drive Shaft (Cont.)		
U-Joint (Cont.)			U-Joint (Cont.)		
1996-1992 E-250: [Type 2]			1992 E-350 & E-350 Club Wagon w/ 2 Joint Shaft & 3 Spd. Trans.: [Type 1]		
U-Joint (Front)⓪		UJ354	U-Joint (Front)⓪		UJ354
Brute Force Greaseable		UJ270	Brute Force Greaseable		UJ270
Brute Force Non Greaseable		UJ254	Brute Force Non Greaseable		UJ254
(For Aluminum Drive Shaft)		UJ354C	(For Aluminum Drive Shaft)		UJ354C
U-Joint (Rear)⓪		UJ434	U-Joint (Rear)⓪		UJ354
Brute Force Greaseable		UJ265	Brute Force Greaseable		UJ270
Brute Force Non Greaseable		UJ264	Brute Force Non Greaseable		UJ254
U-Bolt Kit (Rear)		UJ534-10	(For Aluminum Drive Shaft)		UJ354C
U-Joint (Rear)⓪		UJ354	1992 E-350 & E-350 Club Wagon w/ 2 Joint Shaft & 4 Spd. Trans.: [Type 1]		
Brute Force Greaseable		UJ270	U-Joint (Front)⓪		UJ354
Brute Force Non Greaseable		UJ254	Brute Force Greaseable		UJ270
(For Aluminum Drive Shaft)		UJ354C	Brute Force Non Greaseable		UJ254
1996-1991 E-150 & E-150 Club Wagon: [Type 1]			(For Aluminum Drive Shaft)		UJ354C
U-Joint (Front)⓪		UJ354	U-Joint (Rear)⓪		UJ434
Brute Force Greaseable		UJ270	Brute Force Greaseable		UJ265
Brute Force Non Greaseable		UJ254	Brute Force Non Greaseable		UJ264
(For Aluminum Drive Shaft)		UJ354C	U-Bolt Kit (Rear)		UJ534-10
U-Joint (Rear)⓪		UJ354	1992-1991 E-350 & E-350 Club Wagon w/ 3 Joint Shaft: [Type 2]		
Brute Force Greaseable		UJ270	U-Joint (Front)⓪		UJ354
Brute Force Non Greaseable		UJ254	Brute Force Greaseable		UJ270
(For Aluminum Drive Shaft)		UJ354C	Brute Force Non Greaseable		UJ254
U-Joint (Center)⓪		UJ354	(For Aluminum Drive Shaft)		UJ354C
Brute Force Greaseable		UJ265	U-Joint (Rear)⓪		UJ434
Brute Force Non Greaseable		UJ264	Brute Force Greaseable		UJ265
U-Bolt Kit (Rear)		UJ534-10	Brute Force Non Greaseable		UJ264
1994-1993 E-350 & E-350 Club Wagon w/ 2 Joint Shaft & 5.8L Eng.: [Type 1]			U-Bolt Kit (Rear)		UJ534-10
U-Joint (Front)⓪		UJ354	1991 E-250 & E-250 Club Wagon w/ 4.9L & 5.0L Eng.: [Type 1]		
Brute Force Greaseable		UJ270	U-Joint (Front)⓪		UJ354
Brute Force Non Greaseable		UJ254	Brute Force Greaseable		UJ270
(For Aluminum Drive Shaft)		UJ354C	Brute Force Non Greaseable		UJ254
U-Joint (Rear)⓪		UJ434	(For Aluminum Drive Shaft)		UJ354C
Brute Force Greaseable		UJ265	U-Joint (Rear)⓪		UJ434
Brute Force Non Greaseable		UJ264	Brute Force Greaseable		UJ265
U-Bolt Kit (Rear)		UJ534-10	Brute Force Non Greaseable		UJ264
1994-1993 E-350 & E-350 Club Wagon w/ 3 Joint Shaft & 5.8L Eng.: [Type 2]			U-Bolt Kit (Rear)		UJ534-10
U-Joint (Front)⓪		UJ354			
Brute Force Greaseable		UJ270			
Brute Force Non Greaseable		UJ254			
(For Aluminum Drive Shaft)		UJ354C			
U-Joint (Center)⓪		UJ354			
Brute Force Greaseable		UJ270			
Brute Force Non Greaseable		UJ254			
(For Aluminum Drive Shaft)		UJ354C			
U-Joint (Rear)⓪		UJ434			
Brute Force Greaseable		UJ265			
Brute Force Non Greaseable		UJ264			
U-Bolt Kit (Rear)		UJ534-10			

(Continued)

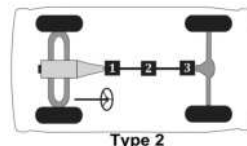
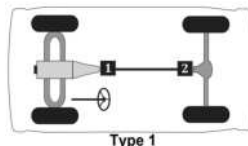

Passenger cars, light & medium trucks

Ford Truck Full size vans, 1/2 ton van, 3/4 ton van, 1 ton van -- (Cont.)

MFG./YEAR	MODEL & LOCATION	PART NO.	MFG./YEAR	MODEL & LOCATION	PART NO.
Drive Shaft (Cont.)			Drive Shaft (Cont.)		
U-Joint (Cont.)			U-Joint (Cont.)		
1991	E-350 & E-350 Club Wagon w/ 2 Joint Shaft & 6 Cyl. Eng.: [Type 1]		1991-1990	E-250 & E-250 Club Wagon w/ 5.8L Eng., 4 Spd. Auto. Trans & 4.10 Rear Axle Ratio: [Type 2]	
	U-Joint (Front)ⓐ	UJ354		U-Joint (Front)ⓐ	UJ354
	Brute Force Greaseable	UJ270		Brute Force Greaseable	UJ270
	Brute Force Non Greaseable	UJ254		Brute Force Non Greaseable	UJ254
	(For Aluminum Drive Shaft)	UJ354C		(For Aluminum Drive Shaft)	UJ354C
	U-Joint (Rear)ⓐ	UJ354		U-Joint (Center)ⓐ	UJ354
	Brute Force Greaseable	UJ270		Brute Force Greaseable	UJ270
	Brute Force Non Greaseable	UJ254		Brute Force Non Greaseable	UJ254
	(For Aluminum Drive Shaft)	UJ354C		(For Aluminum Drive Shaft)	UJ354C
1991	E-350 & E-350 Club Wagon w/ 2 Joint Shaft & 8 Cyl. Eng.: [Type 1]		1991-1990	E-250 Club Wagon w/ 7.3L & 7.5L Engs.: [Type 1]	
	U-Joint (Front)ⓐ	UJ354		U-Joint (Front)ⓐ	UJ354
	Brute Force Greaseable	UJ270		Brute Force Greaseable	UJ270
	Brute Force Non Greaseable	UJ254		Brute Force Non Greaseable	UJ254
	(For Aluminum Drive Shaft)	UJ354C		(For Aluminum Drive Shaft)	UJ354C
	U-Joint (Rear)ⓐ	UJ434		U-Joint (Rear)ⓐ	UJ434
	Brute Force Greaseable	UJ265		Brute Force Greaseable	UJ265
	Brute Force Non Greaseable	UJ264		Brute Force Non Greaseable	UJ264
	U-Bolt Kit (Rear)	UJ534-10		U-Bolt Kit (Rear)	UJ534-10
1991-1990	E-250 & E-250 Club Wagon w/ 5.8L Eng., 3 & 4 Spd. Auto. Trans & 3.54 Rear Axle Ratio: [Type 1]		1991-1990	E-250 w/ 5.0L Eng.: [Type 1]	
	U-Joint (Front)ⓐ	UJ354		U-Joint (Front)ⓐ	UJ354
	Brute Force Greaseable	UJ270		Brute Force Greaseable	UJ270
	Brute Force Non Greaseable	UJ254		Brute Force Non Greaseable	UJ254
	(For Aluminum Drive Shaft)	UJ354C		(For Aluminum Drive Shaft)	UJ354C
	U-Joint (Rear)ⓐ	UJ434		U-Joint (Rear)ⓐ	UJ434
	Brute Force Greaseable	UJ265		Brute Force Greaseable	UJ265
	Brute Force Non Greaseable	UJ264		Brute Force Non Greaseable	UJ264
	U-Bolt Kit (Rear)	UJ534-10		U-Bolt Kit (Rear)	UJ534-10
1991-1990	E-250 & E-250 Club Wagon w/ 5.8L Eng., 3 Spd. Auto. Trans & 4.10 Rear Axle Ratio: [Type 1]		1990	E-250 & E-250 Club Wagon w/ 4.9L Eng., 3 Spd. Auto. Trans. & 3.73 Rear Axle Ratio: [Type 1]	
	U-Joint (Front)ⓐ	UJ354		U-Joint (Front)ⓐ	UJ354
	Brute Force Greaseable	UJ270		Brute Force Greaseable	UJ270
	Brute Force Non Greaseable	UJ254		Brute Force Non Greaseable	UJ254
	(For Aluminum Drive Shaft)	UJ354C		(For Aluminum Drive Shaft)	UJ354C
	U-Joint (Rear)ⓐ	UJ354		U-Joint (Rear)ⓐ	UJ434
	Brute Force Greaseable	UJ270		Brute Force Greaseable	UJ265
	Brute Force Non Greaseable	UJ254		Brute Force Non Greaseable	UJ264
	(For Aluminum Drive Shaft)	UJ354C		U-Bolt Kit (Rear)	UJ534-10

(Continued)

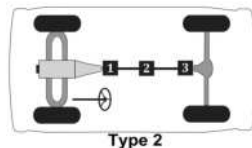
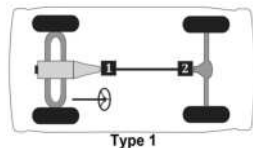

348 ▲ For Use w/ 1.063" Bearing Cap Application. ⓐ For Use w/ 1.188" Bearing Cap Application. ◇ For Use w/ Inner Lock Ring Application on Half Shaft. □ For Use w/ Outer Lock Ring Application on Half Shaft.

Passenger cars, light & medium trucks

(Cont.) -- Ford Truck Full size vans, 1/2 ton van, 3/4 ton van, 1 ton van

MFG./YEAR	MODEL & LOCATION	PART NO.	MFG./YEAR	MODEL & LOCATION	PART NO.
Drive Shaft (Cont.)			Drive Shaft (Cont.)		
U-Joint (Cont.)			U-Joint (Cont.)		
1990	E-250 & E-250 Club Wagon w/ 4.9L Eng., 3 Spd. Auto. Trans. & 4.10 Rear Axle Ratio: [Type 1]		1990	E-350 & E-350 Club Wagon w/ 3 Joint Shaft, 158" Wheel Base & 4.9L Eng.: [Type 2]	
	U-Joint (Front)Ⓢ	UJ354		U-Joint (Front)Ⓢ	UJ437G
	<i>Brute Force Greaseable</i>	UJ270		<i>Brute Force Greaseable</i>	UJ240
	<i>Brute Force Non Greaseable</i>	UJ254		<i>Brute Force Non Greaseable</i>	UJ237
	(For Aluminum Drive Shaft)	UJ354C		Clamp Kit (Front)	UJ437-10
	U-Joint (Rear)Ⓢ	UJ354		U-Joint (Center)Ⓢ	UJ437G
	<i>Brute Force Greaseable</i>	UJ270		<i>Brute Force Greaseable</i>	UJ240
	<i>Brute Force Non Greaseable</i>	UJ254		<i>Brute Force Non Greaseable</i>	UJ237
	(For Aluminum Drive Shaft)	UJ354C		Clamp Kit (Center)	UJ437-10
1990	E-250 & E-250 Club Wagon w/ 4.9L Eng., 4 Spd. Auto. Trans.: [Type 1]			U-Joint (Rear)Ⓢ	UJ437G
	U-Joint (Front)Ⓢ	UJ354		<i>Brute Force Greaseable</i>	UJ240
	<i>Brute Force Greaseable</i>	UJ270		<i>Brute Force Non Greaseable</i>	UJ237
	<i>Brute Force Non Greaseable</i>	UJ254		Clamp Kit (Rear)	UJ437-10
	(For Aluminum Drive Shaft)	UJ354C			
	U-Joint (Rear)Ⓢ	UJ434	1990	E-350 & E-350 Club Wagon w/ 2 Joint Shaft. 3.54 Rear Axle Ratio & 5.8L Eng.: [Type 1]	
	<i>Brute Force Greaseable</i>	UJ265		U-Joint (Front)Ⓢ	UJ354
	<i>Brute Force Non Greaseable</i>	UJ264		<i>Brute Force Greaseable</i>	UJ270
	U-Bolt Kit (Rear)	UJ534-10		<i>Brute Force Non Greaseable</i>	UJ254
1990	E-350 & E-350 Club Wagon w/ 2 Joint Shaft & 4.9L Eng.: [Type 1]			(For Aluminum Drive Shaft)	UJ354C
	U-Joint (Front)Ⓢ	UJ354		U-Joint (Rear)Ⓢ	UJ434
	<i>Brute Force Greaseable</i>	UJ270		<i>Brute Force Greaseable</i>	UJ265
	<i>Brute Force Non Greaseable</i>	UJ254		<i>Brute Force Non Greaseable</i>	UJ264
	(For Aluminum Drive Shaft)	UJ354C		U-Bolt Kit (Rear)	UJ534-10
	U-Joint (Rear)Ⓢ	UJ354	1990	E-350 & E-350 Club Wagon w/ 2 Joint Shaft. 4.10 Rear Axle Ratio & 5.8L Eng.: [Type 1]	
	<i>Brute Force Greaseable</i>	UJ270		U-Joint (Front)Ⓢ	UJ354
	<i>Brute Force Non Greaseable</i>	UJ254		<i>Brute Force Greaseable</i>	UJ270
	(For Aluminum Drive Shaft)	UJ354C		<i>Brute Force Non Greaseable</i>	UJ254
	U-Joint (Rear)Ⓢ	UJ354		(For Aluminum Drive Shaft)	UJ354C
	<i>Brute Force Greaseable</i>	UJ270		U-Joint (Rear)Ⓢ	UJ354
	<i>Brute Force Non Greaseable</i>	UJ254		<i>Brute Force Greaseable</i>	UJ270
	(For Aluminum Drive Shaft)	UJ354C		<i>Brute Force Non Greaseable</i>	UJ254
1990	E-350 & E-350 Club Wagon w/ 3 Joint Shaft, 138" Wheel Base & 4.9L Eng.: [Type 2]			(For Aluminum Drive Shaft)	UJ354C
	U-Joint (Front)Ⓢ	UJ354		1990	E-350 & E-350 Club Wagon w/ 3 Joint Shaft & 5.8L Eng.: [Type 2]
	<i>Brute Force Greaseable</i>	UJ270		U-Joint (Front)Ⓢ	UJ354
	<i>Brute Force Non Greaseable</i>	UJ254		<i>Brute Force Greaseable</i>	UJ270
	(For Aluminum Drive Shaft)	UJ354C		<i>Brute Force Non Greaseable</i>	UJ254
	U-Joint (Center)Ⓢ	UJ354		(For Aluminum Drive Shaft)	UJ354C
	<i>Brute Force Greaseable</i>	UJ270		U-Joint (Center)Ⓢ	UJ354
	<i>Brute Force Non Greaseable</i>	UJ254		<i>Brute Force Greaseable</i>	UJ270
	(For Aluminum Drive Shaft)	UJ354C		<i>Brute Force Non Greaseable</i>	UJ254
	U-Joint (Rear)Ⓢ	UJ434		(For Aluminum Drive Shaft)	UJ354C
	<i>Brute Force Greaseable</i>	UJ265		U-Joint (Rear)Ⓢ	UJ434
	<i>Brute Force Non Greaseable</i>	UJ264		<i>Brute Force Greaseable</i>	UJ265
	U-Bolt Kit (Rear)	UJ534-10		<i>Brute Force Non Greaseable</i>	UJ264
				U-Bolt Kit (Rear)	UJ534-10

(Continued)

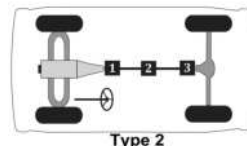
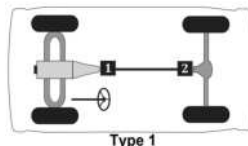

Passenger cars, light & medium trucks

Ford Truck Full size vans, 1/2 ton van, 3/4 ton van, 1 ton van -- (Cont.)

MFG./YEAR	MODEL & LOCATION	PART NO.	MFG./YEAR	MODEL & LOCATION	PART NO.
-----------	------------------	----------	-----------	------------------	----------

Drive Shaft (Cont.)

U-Joint (Cont.)

1990	E-350 & E-350 Club Wagon w/ 2 Joint Shaft, 7.3L & 7.5L Engs.: [Type 1]	
	U-Joint (Front)Ⓛ	UJ354
	<i>Brute Force Greaseable</i>	UJ270
	<i>Brute Force Non Greaseable</i>	UJ254
	(For Aluminum Drive Shaft)	UJ354C
	U-Joint (Rear)Ⓢ	UJ434
	<i>Brute Force Greaseable</i>	UJ265
	<i>Brute Force Non Greaseable</i>	UJ264
	U-Bolt Kit (Rear)	UJ534-10
1990	E-350 & E-350 Club Wagon w/ 3 Joint Shaft, 7.3L & 7.5L Engs.: [Type 2]	
	U-Joint (Front)Ⓛ	UJ354
	<i>Brute Force Greaseable</i>	UJ270
	<i>Brute Force Non Greaseable</i>	UJ254
	(For Aluminum Drive Shaft)	UJ354C
	U-Joint (Center)Ⓢ	UJ354
	<i>Brute Force Greaseable</i>	UJ270
	<i>Brute Force Non Greaseable</i>	UJ254
	(For Aluminum Drive Shaft)	UJ354C
	U-Joint (Rear)Ⓢ	UJ434
	<i>Brute Force Greaseable</i>	UJ265
	<i>Brute Force Non Greaseable</i>	UJ264
	U-Bolt Kit (Rear)	UJ534-10
1990-1989	E-150 & E-150 Club Wagon w/ 3 Joint Shaft: [Type 2]	
	U-Joint (Front)Ⓛ	UJ354
	<i>Brute Force Greaseable</i>	UJ270
	<i>Brute Force Non Greaseable</i>	UJ254
	(For Aluminum Drive Shaft)	UJ354C
	U-Joint (Center)Ⓢ	UJ354
	<i>Brute Force Greaseable</i>	UJ270
	<i>Brute Force Non Greaseable</i>	UJ254
	(For Aluminum Drive Shaft)	UJ354C
	U-Joint (Rear)Ⓢ	UJ354
	<i>Brute Force Greaseable</i>	UJ270
	<i>Brute Force Non Greaseable</i>	UJ254
	(For Aluminum Drive Shaft)	UJ354C
1990-1987	E-150 & E-150 Club Wagon w/ 2 Joint Shaft: [Type 1]	
	U-Joint (Front)Ⓛ	UJ354
	<i>Brute Force Greaseable</i>	UJ270
	<i>Brute Force Non Greaseable</i>	UJ254
	(For Aluminum Drive Shaft)	UJ354C
	U-Joint (Rear)Ⓢ	UJ354
	<i>Brute Force Greaseable</i>	UJ270
	<i>Brute Force Non Greaseable</i>	UJ254
	(For Aluminum Drive Shaft)	UJ354C

Drive Shaft (Cont.)

U-Joint (Cont.)

1989	E-250 & E-250 Club Wagon: [Type 1]	
	U-Joint (Front)Ⓛ	UJ354
	<i>Brute Force Greaseable</i>	UJ270
	<i>Brute Force Non Greaseable</i>	UJ254
	(For Aluminum Drive Shaft)	UJ354C
	U-Joint (Rear)Ⓢ	• UJ434
	<i>Brute Force Greaseable</i>	UJ265
	<i>Brute Force Non Greaseable</i>	UJ264
	U-Bolt Kit (Rear)	UJ534-10
	U-Joint (Rear)Ⓢ	■ UJ354
	<i>Brute Force Greaseable</i>	UJ270
	<i>Brute Force Non Greaseable</i>	UJ254
	(For Aluminum Drive Shaft)	UJ354C
1989	E-350 & E-350 Club Wagon w/ 2 Joint Shaft: [Type 1]	
	U-Joint (Front)Ⓛ	UJ354
	<i>Brute Force Greaseable</i>	UJ270
	<i>Brute Force Non Greaseable</i>	UJ254
	(For Aluminum Drive Shaft)	UJ354C
	U-Joint (Rear)Ⓢ	• UJ434
	<i>Brute Force Greaseable</i>	UJ265
	<i>Brute Force Non Greaseable</i>	UJ264
	U-Bolt Kit (Rear)	UJ534-10
	U-Joint (Rear)Ⓢ	■ UJ354
	<i>Brute Force Greaseable</i>	UJ270
	<i>Brute Force Non Greaseable</i>	UJ254
	(For Aluminum Drive Shaft)	UJ354C
1989	E-350 & E-350 Club Wagon w/ 3 Joint Shaft: [Type 2]	
	U-Joint (Front)Ⓛ	UJ354
	<i>Brute Force Greaseable</i>	UJ270
	<i>Brute Force Non Greaseable</i>	UJ254
	(For Aluminum Drive Shaft)	UJ354C
	U-Joint (Center)Ⓢ	UJ354
	<i>Brute Force Greaseable</i>	UJ270
	<i>Brute Force Non Greaseable</i>	UJ254
	(For Aluminum Drive Shaft)	UJ354C
	U-Joint (Rear)Ⓢ	UJ434
	<i>Brute Force Greaseable</i>	UJ265
	<i>Brute Force Non Greaseable</i>	UJ264
	U-Bolt Kit (Rear)	UJ534-10

(Continued)

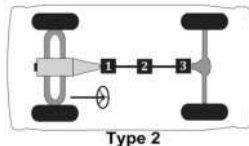
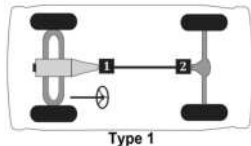

Passenger cars, light & medium trucks

(Cont.) -- Ford Truck Full size vans, 1/2 ton van, 3/4 ton van, 1 ton van

MFG./YEAR	MODEL & LOCATION	PART NO.	MFG./YEAR	MODEL & LOCATION	PART NO.
Drive Shaft (Cont.)			Drive Shaft (Cont.)		
U-Joint (Cont.)			U-Joint (Cont.)		
1988-1987 E-150 & E-150 Club Wagon w/ 3 Joint			1986-1984 E-250 & E-250 Club Wagon w/ 2 Joint		
Shaft: [Type 2]			Shaft: [Type 1]		
U-Joint (Front)Ⓢ		UJ354	U-Joint (Front)Ⓢ		UJ354
Brute Force Greaseable		UJ270	Brute Force Greaseable		UJ270
Brute Force Non Greaseable		UJ254	Brute Force Non Greaseable		UJ254
(For Aluminum Drive Shaft)		UJ354C	(For Aluminum Drive Shaft)		UJ354C
U-Joint (Center)Ⓢ		UJ354	U-Joint (Rear)Ⓢ		UJ434
Brute Force Greaseable		UJ270	Brute Force Greaseable		UJ265
Brute Force Non Greaseable		UJ254	Brute Force Non Greaseable		UJ264
(For Aluminum Drive Shaft)		UJ354C	U-Bolt Kit (Rear)		UJ534-10
U-Joint (Rear)Ⓢ		UJ434	1986-1984 E-250 & E-250 Club Wagon w/ 3 Joint		
Brute Force Greaseable		UJ265	Shaft & Auto. Trans.: [Type 2]		
Brute Force Non Greaseable		UJ264	U-Joint (Front)Ⓢ		UJ354
U-Bolt Kit (Rear)		UJ534-10	Brute Force Greaseable		UJ270
1988-1987 E-250 & E-250 Club Wagon: [Type 1]			Brute Force Non Greaseable		UJ254
U-Joint (Front)Ⓢ		UJ354	(For Aluminum Drive Shaft)		UJ354C
Brute Force Greaseable		UJ270	U-Joint (Center)Ⓢ		UJ354
Brute Force Non Greaseable		UJ254	Brute Force Greaseable		UJ270
(For Aluminum Drive Shaft)		UJ354C	Brute Force Non Greaseable		UJ254
U-Joint (Rear)Ⓢ		UJ434	(For Aluminum Drive Shaft)		UJ354C
Brute Force Greaseable		UJ265	U-Joint (Rear)Ⓢ		UJ434
Brute Force Non Greaseable		UJ264	Brute Force Greaseable		UJ265
U-Bolt Kit (Rear)		UJ534-10	Brute Force Non Greaseable		UJ264
1988-1987 E-350 & E-350 Club Wagon w/ 3 Joint			U-Bolt Kit (Rear)		UJ534-10
Shaft: [Type 2]			1986-1984 E-250 & E-250 Club Wagon w/ 3 Joint		
U-Joint (Front)Ⓢ		UJ434	Shaft & Man. Trans.: [Type 2]		
Brute Force Greaseable		UJ265	U-Joint (Front)Ⓢ		UJ434
Brute Force Non Greaseable		UJ264	Brute Force Greaseable		UJ265
U-Bolt Kit (Front)		UJ534-10	Brute Force Non Greaseable		UJ264
U-Joint (Center)Ⓢ		UJ354	U-Bolt Kit (Front)		UJ534-10
Brute Force Greaseable		UJ270	U-Joint (Center)Ⓢ		UJ354
Brute Force Non Greaseable		UJ254	Brute Force Greaseable		UJ270
(For Aluminum Drive Shaft)		UJ354C	Brute Force Non Greaseable		UJ254
U-Joint (Rear)Ⓢ		UJ434	(For Aluminum Drive Shaft)		UJ354C
Brute Force Greaseable		UJ265	U-Joint (Rear)Ⓢ		UJ434
Brute Force Non Greaseable		UJ264	Brute Force Greaseable		UJ265
U-Bolt Kit (Rear)		UJ534-10	Brute Force Non Greaseable		UJ264
1988-1979 E-350 & E-350 Club Wagon w/ 2 Joint			U-Bolt Kit (Rear)		UJ534-10
Shaft: [Type 1]			1986-1984 E-350 & E-350 Club Wagon w/ 3 Joint		
U-Joint (Front)Ⓢ		UJ354	Shaft & Auto. Trans.: [Type 2]		
Brute Force Greaseable		UJ270	U-Joint (Front)Ⓢ		UJ354
Brute Force Non Greaseable		UJ254	Brute Force Greaseable		UJ270
(For Aluminum Drive Shaft)		UJ354C	Brute Force Non Greaseable		UJ254
U-Joint (Rear)Ⓢ		UJ434	(For Aluminum Drive Shaft)		UJ354C
Brute Force Greaseable		UJ265	U-Joint (Center)Ⓢ		UJ354
Brute Force Non Greaseable		UJ264	Brute Force Greaseable		UJ270
U-Bolt Kit (Rear)		UJ534-10	Brute Force Non Greaseable		UJ254
			(For Aluminum Drive Shaft)		UJ354C
			U-Joint (Rear)Ⓢ		UJ434
			Brute Force Greaseable		UJ265
			Brute Force Non Greaseable		UJ264
			U-Bolt Kit (Rear)		UJ534-10

(Continued)

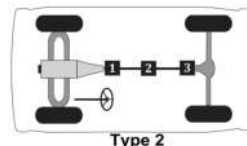
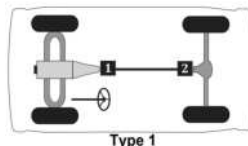

Passenger cars, light & medium trucks

Ford Truck Full size vans, 1/2 ton van, 3/4 ton van, 1 ton van -- (Cont.)

MFG./YEAR	MODEL & LOCATION	PART NO.	MFG./YEAR	MODEL & LOCATION	PART NO.
Drive Shaft (Cont.)			Drive Shaft (Cont.)		
U-Joint (Cont.)			U-Joint (Cont.)		
1986-1984 E-350 & E-350 Club Wagon w/ 3 Joint			1983-1980 E-250 & E-250 Club Wagon w/ 3 Joint		
Shaft & Man. Trans.: [Type 2]			Shaft: [Type 2]		
U-Joint (Front)Ⓛ		UJ434	U-Joint (Front)Ⓛ		UJ354
Brute Force Greaseable		UJ265	Brute Force Greaseable		UJ270
Brute Force Non Greaseable		UJ264	Brute Force Non Greaseable		UJ254
U-Bolt Kit (Front)		UJ534-10	(For Aluminum Drive Shaft)		UJ354C
U-Joint (Center)Ⓢ		UJ354	U-Joint (Center)Ⓢ		UJ354
Brute Force Greaseable		UJ270	Brute Force Greaseable		UJ270
Brute Force Non Greaseable		UJ254	Brute Force Non Greaseable		UJ254
(For Aluminum Drive Shaft)		UJ354C	(For Aluminum Drive Shaft)		UJ354C
U-Joint (Rear)Ⓢ		UJ434	U-Joint (Rear)Ⓢ		UJ434
Brute Force Greaseable		UJ265	Brute Force Greaseable		UJ265
Brute Force Non Greaseable		UJ264	Brute Force Non Greaseable		UJ264
U-Bolt Kit (Rear)		UJ534-10	U-Bolt Kit (Rear)		UJ534-10
1986-1979 E-100, E-100 Club Wagon, E-150 & E-150 Club Wagon w/ 2 Joint Shaft: [Type 1]			1983-1980 E-350 & E-350 Club Wagon w/ 3 Joint Shaft: [Type 2]		
U-Joint (Front)Ⓛ		UJ354	U-Joint (Front)Ⓛ		UJ354
Brute Force Greaseable		UJ270	Brute Force Greaseable		UJ270
Brute Force Non Greaseable		UJ254	Brute Force Non Greaseable		UJ254
(For Aluminum Drive Shaft)		UJ354C	(For Aluminum Drive Shaft)		UJ354C
U-Joint (Rear)Ⓢ		UJ434	U-Joint (Center)Ⓢ		UJ354
Brute Force Greaseable		UJ265	Brute Force Greaseable		UJ270
Brute Force Non Greaseable		UJ264	Brute Force Non Greaseable		UJ254
U-Bolt Kit (Rear)		UJ534-10	(For Aluminum Drive Shaft)		UJ354C
1986-1979 E-100, E-100 Club Wagon, E-150 & E-150 Club Wagon w/ 3 Joint Shaft: [Type 2]			U-Joint (Rear)Ⓢ		
U-Joint (Front)Ⓛ		UJ354	Brute Force Greaseable		UJ434
Brute Force Greaseable		UJ270	Brute Force Greaseable		UJ265
Brute Force Non Greaseable		UJ254	Brute Force Non Greaseable		UJ264
(For Aluminum Drive Shaft)		UJ354C	U-Bolt Kit (Rear)		UJ534-10
U-Joint (Center)Ⓢ		UJ354	1983-1979 E-250 & E-250 Club Wagon w/ 2 Joint Shaft: [Type 1]		
Brute Force Greaseable		UJ270	U-Joint (Front)Ⓛ		UJ354
Brute Force Non Greaseable		UJ254	Brute Force Greaseable		UJ270
(For Aluminum Drive Shaft)		UJ354C	Brute Force Non Greaseable		UJ254
U-Joint (Rear)Ⓢ		UJ434	(For Aluminum Drive Shaft)		UJ354C
Brute Force Greaseable		UJ265	U-Joint (Rear)Ⓢ		UJ354
Brute Force Non Greaseable		UJ264	Brute Force Greaseable		UJ270
U-Bolt Kit (Rear)		UJ534-10	Brute Force Non Greaseable		UJ254
			(For Aluminum Drive Shaft)		UJ354C
			1979 E-250 & E-250 Club Wagon w/ 3 Joint Shaft & 1.063" Dia. Brg. Cap: [Type 2]		
			U-Joint (Front)Ⓛ		UJ354
			Brute Force Greaseable		UJ270
			Brute Force Non Greaseable		UJ254
			(For Aluminum Drive Shaft)		UJ354C
			U-Joint (Center)Ⓢ		UJ354
			Brute Force Greaseable		UJ270
			Brute Force Non Greaseable		UJ254
			(For Aluminum Drive Shaft)		UJ354C
			U-Joint (Rear)Ⓢ		UJ434
			Brute Force Greaseable		UJ265
			Brute Force Non Greaseable		UJ264
			U-Bolt Kit (Rear)		UJ534-10

(Continued)

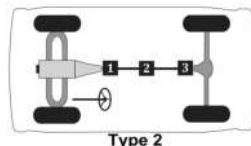
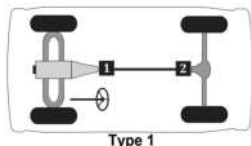

Passenger cars, light & medium trucks

(Cont.) -- Ford Truck Full size vans, 1/2 ton van, 3/4 ton van, 1 ton van

MFG./YEAR	MODEL & LOCATION	PART NO.	MFG./YEAR	MODEL & LOCATION	PART NO.
Drive Shaft (Cont.)			Drive Shaft (Cont.)		
U-Joint (Cont.)			U-Joint (Cont.)		
1979	E-250 & E-250 Club Wagon w/ 3 Joint Shaft & 1.188" Dia. Brg. Cap: [Type 2]		1978-1975	E-100, E-100 Club Wagon, E-150 & E-150 Club Wagon w/ 2 Joint Shaft & 124" Wheel Base: [Type 1]	
	U-Joint (Front)Ⓢ	UJ331		U-Joint (Front)Ⓢ	UJ369
	<i>Brute Force Greaseable</i>	UJ232		<i>Brute Force Greaseable</i>	UJ280
	<i>Brute Force Non Greaseable</i>	UJ231		<i>Brute Force Non Greaseable</i>	UJ269
	(For Aluminum Drive Shaft)	UJ331C		(For Aluminum Drive Shaft)	UJ369C
	U-Joint (Center)Ⓢ	UJ331		U-Bolt Kit (Front)	UJ329-10
	<i>Brute Force Greaseable</i>	UJ232		U-Joint (Rear)Ⓢ	UJ430
	<i>Brute Force Non Greaseable</i>	UJ231		<i>Brute Force Greaseable</i>	UJ255
	(For Aluminum Drive Shaft)	UJ331C		U-Bolt Kit (Rear)	UJ534-10
1979	E-350 & E-350 Club Wagon w/ 3 Joint Shaft & 1.063" Dia. Brg. Cap: [Type 2]		1978-1975	E-100, E-100 Club Wagon, E-150 & E-150 Club Wagon w/ 2 Joint Shaft Exc. 124" Wheel Base: [Type 1]	
	U-Joint (Front)Ⓢ	UJ354		U-Joint (Front)Ⓢ	UJ369
	<i>Brute Force Greaseable</i>	UJ270		<i>Brute Force Greaseable</i>	UJ280
	<i>Brute Force Non Greaseable</i>	UJ254		<i>Brute Force Non Greaseable</i>	UJ269
	(For Aluminum Drive Shaft)	UJ354C		(For Aluminum Drive Shaft)	UJ369C
	U-Joint (Center)Ⓢ	UJ354		U-Bolt Kit (Front)	UJ329-10
	<i>Brute Force Greaseable</i>	UJ270		U-Joint (Rear)Ⓢ	UJ369
	<i>Brute Force Non Greaseable</i>	UJ254		<i>Brute Force Greaseable</i>	UJ280
	(For Aluminum Drive Shaft)	UJ354C		<i>Brute Force Non Greaseable</i>	UJ269
	U-Joint (Rear)Ⓢ	UJ434		(For Aluminum Drive Shaft)	UJ369C
	<i>Brute Force Greaseable</i>	UJ265		U-Bolt Kit (Rear)	UJ329-10
	<i>Brute Force Non Greaseable</i>	UJ264		1978-1975	E-100, E-100 Club Wagon, E-150 & E-150 Club Wagon w/ 3 Joint Shaft, 351 Eng. & Auto. Trans.: [Type 2]
	U-Bolt Kit (Rear)	UJ534-10		U-Joint (Front)Ⓢ	UJ354
1979	E-350 & E-350 Club Wagon w/ 3 Joint Shaft & 1.188" Dia. Brg. Cap: [Type 2]			<i>Brute Force Greaseable</i>	UJ270
	U-Joint (Front)Ⓢ	UJ354		<i>Brute Force Non Greaseable</i>	UJ254
	<i>Brute Force Greaseable</i>	UJ270		(For Aluminum Drive Shaft)	UJ354C
	<i>Brute Force Non Greaseable</i>	UJ254		U-Joint (Center)Ⓢ	UJ354
	(For Aluminum Drive Shaft)	UJ354C		<i>Brute Force Greaseable</i>	UJ270
	U-Joint (Center)Ⓢ	UJ331		<i>Brute Force Non Greaseable</i>	UJ254
	<i>Brute Force Greaseable</i>	UJ232		(For Aluminum Drive Shaft)	UJ354C
	<i>Brute Force Non Greaseable</i>	UJ231		U-Joint (Rear)Ⓢ	UJ369
	(For Aluminum Drive Shaft)	UJ331C		<i>Brute Force Greaseable</i>	UJ280
	U-Joint (Rear)Ⓢ	UJ331		<i>Brute Force Non Greaseable</i>	UJ269
	<i>Brute Force Greaseable</i>	UJ232		(For Aluminum Drive Shaft)	UJ369C
	<i>Brute Force Non Greaseable</i>	UJ231		U-Bolt Kit (Rear)	UJ329-10
	(For Aluminum Drive Shaft)	UJ331C			(Continued)

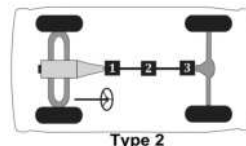
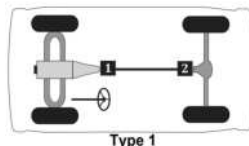

Passenger cars, light & medium trucks

Ford Truck Full size vans, 1/2 ton van, 3/4 ton van, 1 ton van -- (Cont.)

MFG./YEAR	MODEL & LOCATION	PART NO.	MFG./YEAR	MODEL & LOCATION	PART NO.
-----------	------------------	----------	-----------	------------------	----------

Drive Shaft (Cont.)

U-Joint (Cont.)

1978-1975 E-100, E-100 Club Wagon, E-150 & E-150 Club Wagon w/ 3 Joint Shaft
Exc. 351 Eng. & Auto. Trans.: [Type 2]

U-Joint (Front)Ⓚ	UJ369
Brute Force Greaseable	UJ280
Brute Force Non Greaseable	UJ269
(For Aluminum Drive Shaft)	UJ369C
U-Bolt Kit (Front)	UJ329-10
U-Joint (Center)Ⓛ	UJ369
Brute Force Greaseable	UJ280
Brute Force Non Greaseable	UJ269
(For Aluminum Drive Shaft)	UJ369C
U-Bolt Kit (Center)	UJ329-10
U-Joint (Rear)Ⓛ	UJ369
Brute Force Greaseable	UJ280
Brute Force Non Greaseable	UJ269
(For Aluminum Drive Shaft)	UJ369C
U-Bolt Kit (Rear)	UJ329-10

1978-1975 E-250 & E-250 Club Wagon w/ 2 Joint

Shaft: [Type 1]

U-Joint (Front)Ⓚ	UJ354
Brute Force Greaseable	UJ270
Brute Force Non Greaseable	UJ254
(For Aluminum Drive Shaft)	UJ354C
U-Joint (Rear)Ⓛ	UJ354
Brute Force Greaseable	UJ270
Brute Force Non Greaseable	UJ254
(For Aluminum Drive Shaft)	UJ354C

1978-1975 E-250 & E-250 Club Wagon w/ 3 Joint

Shaft: [Type 2]

U-Joint (Front)Ⓚ	UJ354
Brute Force Greaseable	UJ270
Brute Force Non Greaseable	UJ254
(For Aluminum Drive Shaft)	UJ354C
U-Joint (Center)Ⓛ	UJ354
Brute Force Greaseable	UJ270
Brute Force Non Greaseable	UJ254
(For Aluminum Drive Shaft)	UJ354C
U-Joint (Rear)Ⓛ	UJ354
Brute Force Greaseable	UJ270
Brute Force Non Greaseable	UJ254
(For Aluminum Drive Shaft)	UJ354C

1978-1975 E-350 & E-350 Club Wagon w/ 2 Joint

Shaft: [Type 1]

U-Joint (Front)Ⓚ	UJ354
Brute Force Greaseable	UJ270
Brute Force Non Greaseable	UJ254
(For Aluminum Drive Shaft)	UJ354C
U-Joint (Rear)Ⓛ	UJ354
Brute Force Greaseable	UJ270
Brute Force Non Greaseable	UJ254
(For Aluminum Drive Shaft)	UJ354C

Drive Shaft (Cont.)

U-Joint (Cont.)

1978-1975 E-350 & E-350 Club Wagon w/ 3 Joint
Shaft: [Type 2]

U-Joint (Front)Ⓚ	UJ354
Brute Force Greaseable	UJ270
Brute Force Non Greaseable	UJ254
(For Aluminum Drive Shaft)	UJ354C
U-Joint (Center)Ⓛ	UJ354
Brute Force Greaseable	UJ270
Brute Force Non Greaseable	UJ254
(For Aluminum Drive Shaft)	UJ354C
U-Joint (Rear)Ⓛ	UJ354
Brute Force Greaseable	UJ270
Brute Force Non Greaseable	UJ254
(For Aluminum Drive Shaft)	UJ354C

1974-1968 E-100 w/ 2 Joint Shaft: [Type 1]

U-Joint (Front)Ⓚ	UJ369
Brute Force Greaseable	UJ280
Brute Force Non Greaseable	UJ269
(For Aluminum Drive Shaft)	UJ369C
U-Bolt Kit (Front)	UJ329-10
U-Joint (Rear)Ⓛ	UJ369
Brute Force Greaseable	UJ280
Brute Force Non Greaseable	UJ269
(For Aluminum Drive Shaft)	UJ369C
U-Bolt Kit (Rear)	UJ329-10

1974-1968 E-100 w/ 3 Joint Shaft: [Type 2]

U-Joint (Front)Ⓚ	UJ369
Brute Force Greaseable	UJ280
Brute Force Non Greaseable	UJ269
(For Aluminum Drive Shaft)	UJ369C
U-Bolt Kit (Front)	UJ329-10
U-Joint (Center)Ⓛ	UJ369
Brute Force Greaseable	UJ280
Brute Force Non Greaseable	UJ269
(For Aluminum Drive Shaft)	UJ369C
U-Bolt Kit (Center)	UJ329-10

U-Joint (Rear)Ⓛ	UJ369
Brute Force Greaseable	UJ280
Brute Force Non Greaseable	UJ269
(For Aluminum Drive Shaft)	UJ369C
U-Bolt Kit (Rear)	UJ329-10

1974-1968 E-200 w/ 2 Joint Shaft: [Type 1]

U-Joint (Front)Ⓚ	UJ369
Brute Force Greaseable	UJ280
Brute Force Non Greaseable	UJ269
(For Aluminum Drive Shaft)	UJ369C
U-Bolt Kit (Front)	UJ329-10
U-Joint (Rear)Ⓛ	UJ369
Brute Force Greaseable	UJ280
Brute Force Non Greaseable	UJ269
(For Aluminum Drive Shaft)	UJ369C
U-Bolt Kit (Rear)	UJ329-10

(Continued)

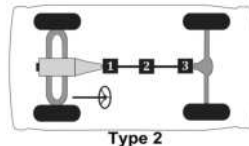
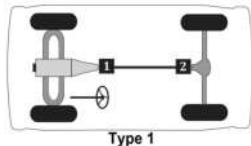

Passenger cars, light & medium trucks

(Cont.) -- Ford Truck Full size vans, 1/2 ton van, 3/4 ton van, 1 ton van

MFG./YEAR	MODEL & LOCATION	PART NO.	MFG./YEAR	MODEL & LOCATION	PART NO.
Drive Shaft (Cont.)			Drive Shaft (Cont.)		
U-Joint (Cont.)			U-Joint (Cont.)		
1974-1968 E-200 w/ 3 Joint Shaft: [Type 2]			1974-1968 E-300 w/ 3 Joint Shaft & 1.063" Dia.		
			Brg. Cap: [Type 2]		
	U-Joint (Front)⓪	UJ369		U-Joint (Front)⓪	UJ369
	<i>Brute Force Greaseable</i>	UJ280		<i>Brute Force Greaseable</i>	UJ280
	<i>Brute Force Non Greaseable</i>	UJ269		<i>Brute Force Non Greaseable</i>	UJ269
	(For Aluminum Drive Shaft)	UJ369C		(For Aluminum Drive Shaft)	UJ369C
	U-Bolt Kit (Front)	UJ329-10		U-Joint (Center)⓪	UJ369
	U-Joint (Center)⓪	UJ369		<i>Brute Force Greaseable</i>	UJ280
	<i>Brute Force Greaseable</i>	UJ280		<i>Brute Force Non Greaseable</i>	UJ269
	<i>Brute Force Non Greaseable</i>	UJ269		(For Aluminum Drive Shaft)	UJ369C
	(For Aluminum Drive Shaft)	UJ369C		U-Joint (Rear)⓪	UJ369
	U-Bolt Kit (Center)	UJ329-10		<i>Brute Force Greaseable</i>	UJ280
	U-Joint (Rear)⓪	UJ369		<i>Brute Force Non Greaseable</i>	UJ269
	<i>Brute Force Greaseable</i>	UJ280		(For Aluminum Drive Shaft)	UJ369C
	<i>Brute Force Non Greaseable</i>	UJ269		1974-1968 E-300 w/ 3 Joint Shaft & 1.188" Dia.	
	(For Aluminum Drive Shaft)	UJ369C		Brg. Cap: [Type 2]	
	U-Bolt Kit (Rear)	UJ329-10		U-Joint (Front)⓪	UJ331
	1974-1968 E-300 w/ 2 Joint Shaft & 1.063" Dia.			<i>Brute Force Greaseable</i>	UJ232
	Brg. Cap: [Type 1]			<i>Brute Force Non Greaseable</i>	UJ231
	U-Joint (Front)⓪	UJ369		(For Aluminum Drive Shaft)	UJ331C
	<i>Brute Force Greaseable</i>	UJ280		U-Joint (Center)⓪	UJ331
	<i>Brute Force Non Greaseable</i>	UJ269		<i>Brute Force Greaseable</i>	UJ232
	(For Aluminum Drive Shaft)	UJ369C		<i>Brute Force Non Greaseable</i>	UJ231
	U-Joint (Rear)⓪	UJ369		(For Aluminum Drive Shaft)	UJ331C
	<i>Brute Force Greaseable</i>	UJ280		U-Joint (Rear)⓪	UJ331
	<i>Brute Force Non Greaseable</i>	UJ269		<i>Brute Force Greaseable</i>	UJ232
	(For Aluminum Drive Shaft)	UJ369C		<i>Brute Force Non Greaseable</i>	UJ231
	1974-1968 E-300 w/ 2 Joint Shaft & 1.188" Dia.			(For Aluminum Drive Shaft)	UJ331C
	Brg. Cap: [Type 1]				
	U-Joint (Front)⓪	UJ331			
	<i>Brute Force Greaseable</i>	UJ232			
	<i>Brute Force Non Greaseable</i>	UJ231			
	(For Aluminum Drive Shaft)	UJ331C			
	U-Joint (Rear)⓪	UJ331			
	<i>Brute Force Greaseable</i>	UJ232			
	<i>Brute Force Non Greaseable</i>	UJ231			
	(For Aluminum Drive Shaft)	UJ331C			

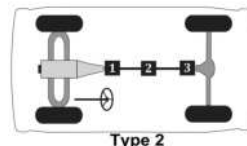
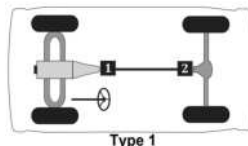

Passenger cars, light & medium trucks

Ford Truck 1/2 ton

MFG./YEAR	MODEL & LOCATION	PART NO.	MFG./YEAR	MODEL & LOCATION	PART NO.
Drive Shaft (2 W/D)			Drive Shaft (2 W/D) (Cont.)		
U-Joint			U-Joint (Cont.)		
2020-2005 F-150 w/ 3 Joint Shaft: [Type 2]			2004 F-150 Heritage w/ 2 Joint Shaft, 4.2L & 4.6L Eng.s.: [Type 1]		
U-Joint (Front)Ⓚ		UJ331	U-Joint (Front)Ⓚ		UJ354
Brute Force Greaseable		UJ232	Brute Force Greaseable		UJ270
Brute Force Non Greaseable		UJ231	Brute Force Non Greaseable		UJ254
(For Aluminum Drive Shaft)		UJ331C	(For Aluminum Drive Shaft)		UJ354C
U-Joint (Center)Ⓚ		UJ331	U-Joint (Rear)Ⓚ		UJ354
Brute Force Greaseable		UJ232	Brute Force Greaseable		UJ270
Brute Force Non Greaseable		UJ231	Brute Force Non Greaseable		UJ254
(For Aluminum Drive Shaft)		UJ331C	(For Aluminum Drive Shaft)		UJ354C
U-Joint (Rear)Ⓚ		UJ331	2004 F-150 Heritage w/ 3 Joint Shaft, 4.2L & 4.6L Eng.s.: [Type 2]		
Brute Force Greaseable		UJ232	U-Joint (Front)Ⓚ		UJ354
Brute Force Non Greaseable		UJ231	Brute Force Greaseable		UJ270
(For Aluminum Drive Shaft)		UJ331C	Brute Force Non Greaseable		UJ254
2014-2005 F-150 w/ 2 Joint Shaft: [Type 1]			(For Aluminum Drive Shaft)		UJ354C
U-Joint (Front)Ⓚ		UJ331	U-Joint (Center)Ⓚ		UJ354
Brute Force Greaseable		UJ232	Brute Force Greaseable		UJ270
Brute Force Non Greaseable		UJ231	Brute Force Non Greaseable		UJ254
(For Aluminum Drive Shaft)		UJ331C	(For Aluminum Drive Shaft)		UJ354C
U-Joint (Rear)Ⓚ		UJ331	U-Joint (Rear)Ⓚ		UJ354
Brute Force Greaseable		UJ232	Brute Force Greaseable		UJ270
Brute Force Non Greaseable		UJ231	Brute Force Non Greaseable		UJ254
(For Aluminum Drive Shaft)		UJ331C	(For Aluminum Drive Shaft)		UJ354C
2007-2004 F-150 w/ Staked U-Joints: [Type 1]			2004 F-150 Heritage w/ 2 Joint Shaft & 5.4L Eng.: [Type 1]		
U-Joint (Front)Ⓚ		UJ30488	U-Joint (Front)Ⓚ		UJ331
U-Joint (Rear)Ⓚ		UJ30488	Brute Force Greaseable		UJ232
2004 F-150 w/ 2 Joint Shaft Exc. Heritage: [Type 1]			Brute Force Non Greaseable		UJ231
U-Joint (Front)Ⓚ		UJ331	(For Aluminum Drive Shaft)		UJ331C
Brute Force Greaseable		UJ232	U-Joint (Rear)Ⓚ		UJ331
Brute Force Non Greaseable		UJ231	Brute Force Greaseable		UJ232
(For Aluminum Drive Shaft)		UJ331C	Brute Force Non Greaseable		UJ231
U-Joint (Rear)Ⓚ		UJ331	(For Aluminum Drive Shaft)		UJ331C
Brute Force Greaseable		UJ232	2004 F-150 Heritage w/ 3 Joint Shaft & 5.4L Eng.: [Type 2]		
Brute Force Non Greaseable		UJ231	U-Joint (Front)Ⓚ		UJ331
(For Aluminum Drive Shaft)		UJ331C	Brute Force Greaseable		UJ232
2004 F-150 w/ 3 Joint Shaft Exc. Heritage: [Type 2]			Brute Force Non Greaseable		UJ231
U-Joint (Front)Ⓚ		UJ331	(For Aluminum Drive Shaft)		UJ331C
Brute Force Greaseable		UJ232	U-Joint (Center)Ⓚ		UJ331
Brute Force Non Greaseable		UJ231	Brute Force Greaseable		UJ232
(For Aluminum Drive Shaft)		UJ331C	Brute Force Non Greaseable		UJ231
U-Joint (Center)Ⓚ		UJ331	(For Aluminum Drive Shaft)		UJ331C
Brute Force Greaseable		UJ232	U-Joint (Rear)Ⓚ		UJ331
Brute Force Non Greaseable		UJ231	Brute Force Greaseable		UJ232
(For Aluminum Drive Shaft)		UJ331C	Brute Force Non Greaseable		UJ231
U-Joint (Rear)Ⓚ		UJ331	(For Aluminum Drive Shaft)		UJ331C
Brute Force Greaseable		UJ232			(Continued)
Brute Force Non Greaseable		UJ231			
(For Aluminum Drive Shaft)		UJ331C			

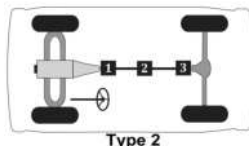
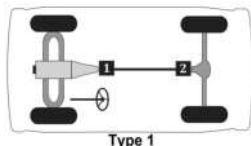

MFG./YEAR	MODEL & LOCATION	PART NO.	MFG./YEAR	MODEL & LOCATION	PART NO.
Drive Shaft (2 W/D) (Cont.)			Drive Shaft (2 W/D) (Cont.)		
U-Joint (Cont.)			U-Joint (Cont.)		
2003-1997 F-150 w/ 2 Joint Shaft, 4.2L & 4.6L			2003-1997 F-150 w/ 2 Joint Shaft, 1.188" Dia. Brg.		
Engs.: [Type 1]			Cap & 5.4L Eng.: [Type 1]		
U-Joint (Front)Ⓢ		UJ354	U-Joint (Front)Ⓢ		UJ331
Brute Force Greaseable		UJ270	Brute Force Greaseable		UJ232
Brute Force Non Greaseable		UJ254	Brute Force Non Greaseable		UJ231
(For Aluminum Drive Shaft)		UJ354C	(For Aluminum Drive Shaft)		UJ331C
U-Joint (Rear)Ⓢ		UJ354	U-Joint (Rear)Ⓢ		UJ331
Brute Force Greaseable		UJ270	Brute Force Greaseable		UJ232
Brute Force Non Greaseable		UJ254	Brute Force Non Greaseable		UJ231
(For Aluminum Drive Shaft)		UJ354C	(For Aluminum Drive Shaft)		UJ331C
2003-1997 F-150 w/ 3 Joint Shaft, 4.2L & 4.6L			2003-1997 F-150 w/ 3 Joint Shaft, 1.188" Dia. Brg.		
Engs.: [Type 2]			Cap & 5.4L Eng.: [Type 2]		
U-Joint (Front)Ⓢ		UJ354	U-Joint (Front)Ⓢ		UJ331
Brute Force Greaseable		UJ270	Brute Force Greaseable		UJ232
Brute Force Non Greaseable		UJ254	Brute Force Non Greaseable		UJ231
(For Aluminum Drive Shaft)		UJ354C	(For Aluminum Drive Shaft)		UJ331C
U-Joint (Center)Ⓢ		UJ354	U-Joint (Center)Ⓢ		UJ331
Brute Force Greaseable		UJ270	Brute Force Greaseable		UJ232
Brute Force Non Greaseable		UJ254	Brute Force Non Greaseable		UJ231
(For Aluminum Drive Shaft)		UJ354C	(For Aluminum Drive Shaft)		UJ331C
U-Joint (Rear)Ⓢ		UJ354	U-Joint (Rear)Ⓢ		UJ331
Brute Force Greaseable		UJ270	Brute Force Greaseable		UJ232
Brute Force Non Greaseable		UJ254	Brute Force Non Greaseable		UJ231
(For Aluminum Drive Shaft)		UJ354C	(For Aluminum Drive Shaft)		UJ331C
2003-1997 F-150 w/ 2 Joint Shaft, 1.063" Dia. Brg.			1996-1991 F-150 w/ Standard Cab & Short Bed:		
Cap & 5.4L Eng.: [Type 1]			[Type 1]		
U-Joint (Front)Ⓢ		UJ354	U-Joint (Front)Ⓢ		UJ354
Brute Force Greaseable		UJ270	Brute Force Greaseable		UJ270
Brute Force Non Greaseable		UJ254	Brute Force Non Greaseable		UJ254
(For Aluminum Drive Shaft)		UJ354C	(For Aluminum Drive Shaft)		UJ354C
U-Joint (Rear)Ⓢ		UJ354	U-Joint (Rear)Ⓢ		UJ354
Brute Force Greaseable		UJ270	Brute Force Greaseable		UJ270
Brute Force Non Greaseable		UJ254	Brute Force Non Greaseable		UJ254
(For Aluminum Drive Shaft)		UJ354C	(For Aluminum Drive Shaft)		UJ354C
2003-1997 F-150 w/ 3 Joint Shaft, 1.063" Dia. Brg.			1996-1991 F-150 w/ Standard Cab, Long Bed & 2		
Cap & 5.4L Eng.: [Type 2]			Joint Shaft Exc. HD 5 Spd. Man.		
U-Joint (Front)Ⓢ		UJ354	Trans.: [Type 1]		
Brute Force Greaseable		UJ270	U-Joint (Front)Ⓢ		UJ354
Brute Force Non Greaseable		UJ254	Brute Force Greaseable		UJ270
(For Aluminum Drive Shaft)		UJ354C	Brute Force Non Greaseable		UJ254
U-Joint (Center)Ⓢ		UJ354	(For Aluminum Drive Shaft)		UJ354C
Brute Force Greaseable		UJ270	U-Joint (Rear)Ⓢ		UJ354
Brute Force Non Greaseable		UJ254	Brute Force Greaseable		UJ270
(For Aluminum Drive Shaft)		UJ354C	Brute Force Non Greaseable		UJ254
U-Joint (Rear)Ⓢ		UJ354	(For Aluminum Drive Shaft)		UJ354C
Brute Force Greaseable		UJ270			(Continued)
Brute Force Non Greaseable		UJ254			
(For Aluminum Drive Shaft)		UJ354C			

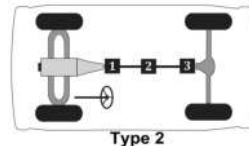
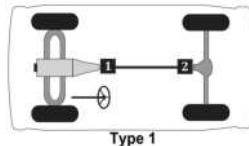

Passenger cars, light & medium trucks

Ford Truck 1/2 ton -- (Cont.)

MFG./YEAR	MODEL & LOCATION	PART NO.	MFG./YEAR	MODEL & LOCATION	PART NO.
Drive Shaft (2 W/D) (Cont.)			Drive Shaft (2 W/D) (Cont.)		
U-Joint (Cont.)			U-Joint (Cont.)		
1996-1991 F-150 w/ Standard Cab, Long Bed & 3 Joint Shaft Exc. HD 5 Spd. Man. Trans.: [Type 2]			1990-1989 F-150 w/ 2 Joint Shaft, Standard Cab Long Bed: [Type 1]		
U-Joint (Front)Ⓚ		UJ354	U-Joint (Front)Ⓚ		UJ354
<i>Brute Force Greaseable</i>		UJ270	<i>Brute Force Greaseable</i>		UJ270
<i>Brute Force Non Greaseable</i>		UJ254	<i>Brute Force Non Greaseable</i>		UJ254
(For Aluminum Drive Shaft)		UJ354C	(For Aluminum Drive Shaft)		UJ354C
U-Joint (Center)Ⓚ		UJ354	U-Joint (Rear)Ⓚ		UJ434
<i>Brute Force Greaseable</i>		UJ270	<i>Brute Force Greaseable</i>		UJ265
<i>Brute Force Non Greaseable</i>		UJ254	<i>Brute Force Non Greaseable</i>		UJ264
(For Aluminum Drive Shaft)		UJ354C	U-Bolt Kit (Rear)		UJ534-10
U-Joint (Rear)Ⓚ		UJ354	1990-1989 F-150 w/ 3 Joint Shaft & HD 5 Spd. Man. Trans.: [Type 2]		
<i>Brute Force Greaseable</i>		UJ270	U-Joint (Front)Ⓚ		UJ434
<i>Brute Force Non Greaseable</i>		UJ254	<i>Brute Force Greaseable</i>		UJ265
(For Aluminum Drive Shaft)		UJ354C	<i>Brute Force Non Greaseable</i>		UJ264
1996-1991 F-150 w/ Standard Cab, Long Bed & HD 5 Spd. Man. Trans.: [Type 2]			U-Bolt Kit (Front)		UJ534-10
U-Joint (Front)Ⓚ		UJ434	U-Joint (Center)Ⓚ		UJ354
<i>Brute Force Greaseable</i>		UJ265	<i>Brute Force Greaseable</i>		UJ270
<i>Brute Force Non Greaseable</i>		UJ264	<i>Brute Force Non Greaseable</i>		UJ254
U-Bolt Kit (Front)		UJ534-10	(For Aluminum Drive Shaft)		UJ354C
U-Joint (Center)Ⓚ		UJ354	U-Joint (Rear)Ⓚ		UJ434
<i>Brute Force Greaseable</i>		UJ270	<i>Brute Force Greaseable</i>		UJ265
<i>Brute Force Non Greaseable</i>		UJ254	<i>Brute Force Non Greaseable</i>		UJ264
(For Aluminum Drive Shaft)		UJ354C	U-Bolt Kit (Rear)		UJ534-10
U-Joint (Rear)Ⓚ		UJ354	1990-1989 F-150 w/ 3 Joint Shaft & Std. Duty 5 Spd. Man. Trans.: [Type 2]		
<i>Brute Force Greaseable</i>		UJ270	U-Joint (Front)Ⓚ		UJ354
<i>Brute Force Non Greaseable</i>		UJ254	<i>Brute Force Greaseable</i>		UJ270
(For Aluminum Drive Shaft)		UJ354C	<i>Brute Force Non Greaseable</i>		UJ254
1996-1990 F-150 w/ Extended Cab: [Type 2]			(For Aluminum Drive Shaft)		UJ354C
U-Joint (Front)Ⓚ		UJ354	U-Joint (Center)Ⓚ		UJ354
<i>Brute Force Greaseable</i>		UJ270	<i>Brute Force Greaseable</i>		UJ270
<i>Brute Force Non Greaseable</i>		UJ254	<i>Brute Force Non Greaseable</i>		UJ254
(For Aluminum Drive Shaft)		UJ354C	(For Aluminum Drive Shaft)		UJ354C
U-Joint (Center)Ⓚ		UJ354	U-Joint (Rear)Ⓚ		UJ434
<i>Brute Force Greaseable</i>		UJ270	<i>Brute Force Greaseable</i>		UJ265
<i>Brute Force Non Greaseable</i>		UJ254	<i>Brute Force Non Greaseable</i>		UJ264
(For Aluminum Drive Shaft)		UJ354C	U-Bolt Kit (Rear)		UJ534-10
U-Joint (Rear)Ⓚ		UJ354	1989 F-150 w/ Extended Cab: [Type 2]		
<i>Brute Force Greaseable</i>		UJ270	U-Joint (Front)Ⓚ		UJ354
<i>Brute Force Non Greaseable</i>		UJ254	<i>Brute Force Greaseable</i>		UJ270
(For Aluminum Drive Shaft)		UJ354C	<i>Brute Force Non Greaseable</i>		UJ254
1990-1989 F-150 w/ Standard Cab & Short Bed: [Type 1]			(For Aluminum Drive Shaft)		UJ354C
U-Joint (Front)Ⓚ		UJ354	U-Joint (Center)Ⓚ		UJ354
<i>Brute Force Greaseable</i>		UJ270	<i>Brute Force Greaseable</i>		UJ270
<i>Brute Force Non Greaseable</i>		UJ254	<i>Brute Force Non Greaseable</i>		UJ254
(For Aluminum Drive Shaft)		UJ354C	(For Aluminum Drive Shaft)		UJ354C
U-Joint (Rear)Ⓚ		UJ434	U-Joint (Rear)Ⓚ		UJ434
<i>Brute Force Greaseable</i>		UJ265	<i>Brute Force Greaseable</i>		UJ265
<i>Brute Force Non Greaseable</i>		UJ264	<i>Brute Force Non Greaseable</i>		UJ264
U-Bolt Kit (Rear)		UJ534-10	U-Bolt Kit (Rear)		UJ534-10

(Continued)

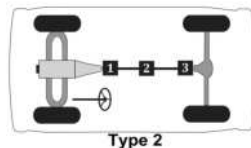
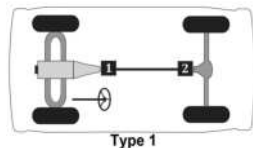

MFG./YEAR	MODEL & LOCATION	PART NO.	MFG./YEAR	MODEL & LOCATION	PART NO.
Drive Shaft (2 W/D) (Cont.)			Drive Shaft (2 W/D) (Cont.)		
U-Joint (Cont.)			U-Joint (Cont.)		
1988	F-150 w/ 2 Joint Shaft: [Type 1]		1987-1979 F-100 & F-150 w/ 3 Joint Shaft: [Type 2]		
	U-Joint (Front)Ⓢ	UJ354	U-Joint (Front)Ⓢ		UJ354
	<i>Brute Force Greaseable</i>	UJ270	<i>Brute Force Greaseable</i>		UJ270
	<i>Brute Force Non Greaseable</i>	UJ254	<i>Brute Force Non Greaseable</i>		UJ254
	(For Aluminum Drive Shaft)	UJ354C	(For Aluminum Drive Shaft)		UJ354C
	U-Joint (Rear)Ⓢ	UJ434	U-Joint (Center)Ⓢ		UJ354
	<i>Brute Force Greaseable</i>	UJ265	<i>Brute Force Greaseable</i>		UJ270
	<i>Brute Force Non Greaseable</i>	UJ264	<i>Brute Force Non Greaseable</i>		UJ254
	U-Bolt Kit (Rear)	UJ534-10	(For Aluminum Drive Shaft)		UJ354C
1988	F-150 w/ 3 Joint Shaft & HD 5 Spd.		U-Joint (Rear)Ⓢ		UJ434
	Man. Trans.: [Type 2]		<i>Brute Force Greaseable</i>		UJ265
	U-Joint (Front)Ⓢ	UJ434	<i>Brute Force Non Greaseable</i>		UJ264
	<i>Brute Force Greaseable</i>	UJ265	U-Bolt Kit (Rear)		UJ534-10
	<i>Brute Force Non Greaseable</i>	UJ264	1978-1977 F-150 w/ Std. Cab, Auto. Trans., 400		
	(For Aluminum Drive Shaft)	UJ354C	Eng. & 2.75 Rear Axle Ratio.: [Type 2]		
	U-Joint (Center)Ⓢ	UJ354	U-Joint (Front)Ⓢ		UJ354
	<i>Brute Force Greaseable</i>	UJ270	<i>Brute Force Greaseable</i>		UJ270
	<i>Brute Force Non Greaseable</i>	UJ254	<i>Brute Force Non Greaseable</i>		UJ254
	(For Aluminum Drive Shaft)	UJ354C	(For Aluminum Drive Shaft)		UJ354C
	U-Joint (Rear)Ⓢ	UJ434	U-Joint (Center)Ⓢ		UJ354
	<i>Brute Force Greaseable</i>	UJ265	<i>Brute Force Greaseable</i>		UJ270
	<i>Brute Force Non Greaseable</i>	UJ264	<i>Brute Force Non Greaseable</i>		UJ254
	U-Bolt Kit (Rear)	UJ534-10	(For Aluminum Drive Shaft)		UJ354C
1988	F-150 w/ 3 Joint Shaft Exc. HD 5 Spd.		U-Joint (Rear)Ⓢ		UJ354
	Man. Trans.: [Type 2]		<i>Brute Force Greaseable</i>		UJ270
	U-Joint (Front)Ⓢ	UJ354	<i>Brute Force Non Greaseable</i>		UJ254
	<i>Brute Force Greaseable</i>	UJ270	(For Aluminum Drive Shaft)		UJ354C
	<i>Brute Force Non Greaseable</i>	UJ254	U-Joint (Center)Ⓢ		UJ354
	(For Aluminum Drive Shaft)	UJ354C	<i>Brute Force Greaseable</i>		UJ270
	U-Joint (Center)Ⓢ	UJ354	<i>Brute Force Non Greaseable</i>		UJ254
	<i>Brute Force Greaseable</i>	UJ270	(For Aluminum Drive Shaft)		UJ354C
	<i>Brute Force Non Greaseable</i>	UJ254	U-Joint (Rear)Ⓢ		UJ354
	(For Aluminum Drive Shaft)	UJ354C	<i>Brute Force Greaseable</i>		UJ270
	U-Joint (Rear)Ⓢ	UJ434	<i>Brute Force Non Greaseable</i>		UJ254
	<i>Brute Force Greaseable</i>	UJ265	(For Aluminum Drive Shaft)		UJ354C
	<i>Brute Force Non Greaseable</i>	UJ264	1978-1977 F-150 w/ Std. Cab, Auto. Trans., 400		
	U-Bolt Kit (Rear)	UJ534-10	Eng. & 3.25 Rear Axle Ratio.: [Type 2]		
1987-1979 F-100 & F-150 w/ 2 Joint Shaft: [Type 1]			U-Joint (Front)Ⓢ		UJ353
	U-Joint (Front)Ⓢ	UJ354	<i>Brute Force Greaseable</i>		UJ275
	<i>Brute Force Greaseable</i>	UJ270	U-Joint (Center)Ⓢ		UJ354
	<i>Brute Force Non Greaseable</i>	UJ254	<i>Brute Force Greaseable</i>		UJ270
	(For Aluminum Drive Shaft)	UJ354C	<i>Brute Force Non Greaseable</i>		UJ254
	U-Joint (Rear)Ⓢ	UJ434	(For Aluminum Drive Shaft)		UJ354C
	<i>Brute Force Greaseable</i>	UJ265	U-Joint (Rear)Ⓢ		UJ354
	<i>Brute Force Non Greaseable</i>	UJ264	<i>Brute Force Greaseable</i>		UJ270
	U-Bolt Kit (Rear)	UJ534-10	<i>Brute Force Non Greaseable</i>		UJ254
			(For Aluminum Drive Shaft)		UJ354C

(Continued)

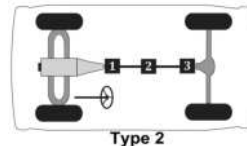
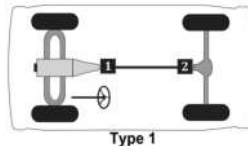

Passenger cars, light & medium trucks

Ford Truck 1/2 ton -- (Cont.)

MFG./YEAR	MODEL & LOCATION	PART NO.	MFG./YEAR	MODEL & LOCATION	PART NO.
Drive Shaft (2 W/D) (Cont.)			Drive Shaft (2 W/D) (Cont.)		
U-Joint (Cont.)			U-Joint (Cont.)		
1978-1977 F-150 w/ Ext. Cab, Auto. Trans. & 400			1978-1975 F-150 w/ 3 Joint Shaft & Auto. Trans.		
Eng.: [Type 2]			Exc. 400 & 460 Eng.: [Type 2]		
U-Joint (Front)ⓐ		UJ353	U-Joint (Front)ⓐ		UJ369
Brute Force Greaseable		UJ275	Brute Force Greaseable		UJ280
U-Joint (Center)ⓑ		UJ354	Brute Force Non Greaseable		UJ269
Brute Force Greaseable		UJ270	(For Aluminum Drive Shaft)		UJ369C
Brute Force Non Greaseable		UJ254	U-Joint (Center)ⓑ		UJ369
(For Aluminum Drive Shaft)		UJ354C	Brute Force Greaseable		UJ280
U-Joint (Rear)ⓐ		UJ354	Brute Force Non Greaseable		UJ269
Brute Force Greaseable		UJ270	(For Aluminum Drive Shaft)		UJ369C
Brute Force Non Greaseable		UJ254	U-Joint (Rear)ⓐ		UJ369
(For Aluminum Drive Shaft)		UJ354C	Brute Force Greaseable		UJ280
1978-1975 F-150 w/ 2 Joint Shaft & Man. Trans.:			Brute Force Non Greaseable		UJ269
[Type 1]			(For Aluminum Drive Shaft)		UJ369C
U-Joint (Front)ⓐ		UJ369	1978-1975 F-150 w/ Std. Cab, Auto. Trans. & 460		
Brute Force Greaseable		UJ280	Eng.: [Type 2]		
Brute Force Non Greaseable		UJ269	U-Joint (Front)ⓐ		UJ354
(For Aluminum Drive Shaft)		UJ369C	Brute Force Greaseable		UJ270
U-Joint (Rear)ⓐ		UJ369	Brute Force Non Greaseable		UJ254
Brute Force Greaseable		UJ280	(For Aluminum Drive Shaft)		UJ354C
Brute Force Non Greaseable		UJ269	U-Joint (Center)ⓑ		UJ354
(For Aluminum Drive Shaft)		UJ369C	Brute Force Greaseable		UJ270
1978-1975 F-150 w/ 3 Joint Shaft & Man. Trans.:			Brute Force Non Greaseable		UJ254
[Type 2]			(For Aluminum Drive Shaft)		UJ354C
U-Joint (Front)ⓐ		UJ369	U-Joint (Rear)ⓐ		UJ354
Brute Force Greaseable		UJ280	Brute Force Greaseable		UJ270
Brute Force Non Greaseable		UJ269	Brute Force Non Greaseable		UJ254
(For Aluminum Drive Shaft)		UJ369C	(For Aluminum Drive Shaft)		UJ354C
U-Joint (Center)ⓑ		UJ369	1978-1975 F-150 w/ Ext. Cab, Auto. Trans. & 460		
Brute Force Greaseable		UJ280	Eng.: [Type 2]		
Brute Force Non Greaseable		UJ269	U-Joint (Front)ⓐ		UJ354
(For Aluminum Drive Shaft)		UJ369C	Brute Force Greaseable		UJ270
U-Joint (Rear)ⓐ		UJ369	Brute Force Non Greaseable		UJ254
Brute Force Greaseable		UJ280	(For Aluminum Drive Shaft)		UJ354C
Brute Force Non Greaseable		UJ269	U-Joint (Center)ⓑ		UJ353
(For Aluminum Drive Shaft)		UJ369C	Brute Force Greaseable		UJ275
1978-1975 F-150 w/ 2 Joint Shaft & Auto. Trans.			U-Joint (Rear)ⓐ		UJ353
Exc. 400 & 460 Eng.: [Type 1]			Brute Force Greaseable		UJ275
U-Joint (Front)ⓐ		UJ369	1978-1973 F-100 w/ 2 Joint Shaft & 460 Eng.:		
Brute Force Greaseable		UJ280	[Type 1]		
Brute Force Non Greaseable		UJ269	U-Joint (Front)ⓐ		UJ354
(For Aluminum Drive Shaft)		UJ369C	Brute Force Greaseable		UJ270
U-Joint (Rear)ⓐ		UJ369	Brute Force Non Greaseable		UJ254
Brute Force Greaseable		UJ280	(For Aluminum Drive Shaft)		UJ354C
Brute Force Non Greaseable		UJ269	U-Joint (Rear)ⓐ		UJ434
(For Aluminum Drive Shaft)		UJ369C	Brute Force Greaseable		UJ265
			Brute Force Non Greaseable		UJ264
			U-Bolt Kit (Rear)		UJ534-10
					(Continued)

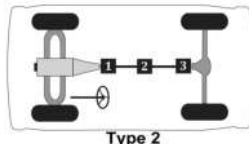
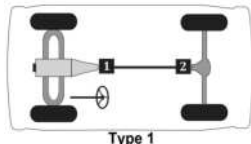

MFG./YEAR	MODEL & LOCATION	PART NO.	MFG./YEAR	MODEL & LOCATION	PART NO.
Drive Shaft (2 W/D) (Cont.)			Drive Shaft (2 W/D) (Cont.)		
U-Joint (Cont.)			U-Joint (Cont.)		
1978-1973 F-100 w/ 3 Joint Shaft & 460 Eng.:			1972-1953 F-100 w/ 3 Joint Shaft: [Type 2]		
	[Type 2]		U-Joint (Front)Ⓢ		UJ369
	U-Joint (Front)Ⓢ	UJ354	Brute Force Greaseable		UJ280
	Brute Force Greaseable	UJ270	Brute Force Non Greaseable		UJ269
	Brute Force Non Greaseable	UJ254	(For Aluminum Drive Shaft)		UJ369C
	(For Aluminum Drive Shaft)	UJ354C	U-Bolt Kit (Front)		UJ329-10
	U-Joint (Center)Ⓢ	UJ354	U-Joint (Center)Ⓢ		UJ369
	Brute Force Greaseable	UJ270	Brute Force Greaseable		UJ280
	Brute Force Non Greaseable	UJ254	Brute Force Non Greaseable		UJ269
	(For Aluminum Drive Shaft)	UJ354C	(For Aluminum Drive Shaft)		UJ369C
	U-Joint (Rear)Ⓢ	UJ434	U-Bolt Kit (Center)		UJ329-10
	Brute Force Greaseable	UJ265	U-Joint (Rear)Ⓢ		UJ369
	Brute Force Non Greaseable	UJ264	Brute Force Greaseable		UJ280
	1978-1973 F-100 w/ 2 Joint Shaft Exc. 460 Eng.:		Brute Force Non Greaseable		UJ269
	[Type 1]		(For Aluminum Drive Shaft)		UJ369C
	U-Joint (Front)Ⓢ	UJ369	U-Bolt Kit (Rear)		UJ329-10
	Brute Force Greaseable	UJ280	Drive Shaft (4 W/D)		
	Brute Force Non Greaseable	UJ269	U-Joint		
	(For Aluminum Drive Shaft)	UJ369C	2020-2015 F-150 w/ 3 Joint Shaft: [Type 18]		
	U-Joint (Rear)Ⓢ	UJ369	U-Joint (Rr. Shaft; Frt.)Ⓢ		UJ331
	Brute Force Greaseable	UJ280	Brute Force Greaseable		UJ232
	Brute Force Non Greaseable	UJ269	Brute Force Non Greaseable		UJ231
	(For Aluminum Drive Shaft)	UJ369C	(For Aluminum Drive Shaft)		UJ331C
	1978-1973 F-100 w/ 3 Joint Shaft Exc. 460 Eng.:		U-Joint (Rr. Shaft; Ctr.)Ⓢ		UJ331
	[Type 2]		Brute Force Greaseable		UJ232
	U-Joint (Front)Ⓢ	UJ369	Brute Force Non Greaseable		UJ231
	Brute Force Greaseable	UJ280	(For Aluminum Drive Shaft)		UJ331C
	Brute Force Non Greaseable	UJ269	U-Joint (Rr. Shaft; Rr.)Ⓢ		UJ331
	(For Aluminum Drive Shaft)	UJ369C	Brute Force Greaseable		UJ232
	U-Joint (Center)Ⓢ	UJ369	Brute Force Non Greaseable		UJ231
	Brute Force Greaseable	UJ280	(For Aluminum Drive Shaft)		UJ331C
	Brute Force Non Greaseable	UJ269	2014-2008 F-150 w/ 2 Joint Shaft: [Type 13]		
	(For Aluminum Drive Shaft)	UJ369C	U-Joint (Frt. Shaft; Frt.)Ⓢ		UJ331
	U-Joint (Rear)Ⓢ	UJ369	Brute Force Greaseable		UJ232
	Brute Force Greaseable	UJ280	Brute Force Non Greaseable		UJ231
	Brute Force Non Greaseable	UJ269	(For Aluminum Drive Shaft)		UJ331C
	(For Aluminum Drive Shaft)	UJ369C	U-Joint (Frt. Shaft; Rr.)Ⓢ		UJ331
	1972-1953 F-100 w/ 2 Joint Shaft: [Type 1]		Brute Force Greaseable		UJ232
	U-Joint (Front)Ⓢ	UJ369	Brute Force Non Greaseable		UJ231
	Brute Force Greaseable	UJ280	(For Aluminum Drive Shaft)		UJ331C
	Brute Force Non Greaseable	UJ269	U-Joint (Rr. Shaft; Frt.)Ⓢ		UJ331
	(For Aluminum Drive Shaft)	UJ369C	Brute Force Greaseable		UJ232
	U-Bolt Kit (Front)	UJ329-10	Brute Force Non Greaseable		UJ231
	U-Joint (Rear)Ⓢ	UJ369	(For Aluminum Drive Shaft)		UJ331C
	Brute Force Greaseable	UJ280	U-Joint (Rr. Shaft; Rr.)Ⓢ		UJ331
	Brute Force Non Greaseable	UJ269	Brute Force Greaseable		UJ232
	(For Aluminum Drive Shaft)	UJ369C	Brute Force Non Greaseable		UJ231
	U-Bolt Kit (Rear)	UJ329-10	(For Aluminum Drive Shaft)		UJ331C

(Continued)

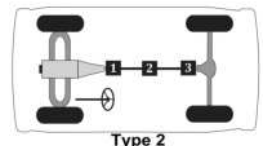
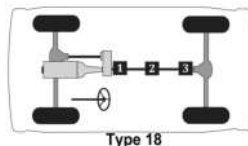
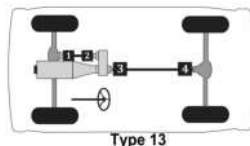
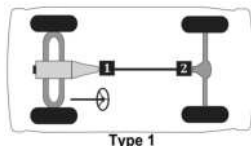

Passenger cars, light & medium trucks

Ford Truck 1/2 ton -- (Cont.)

MFG./YEAR	MODEL & LOCATION	PART NO.	MFG./YEAR	MODEL & LOCATION	PART NO.
Drive Shaft (4 W/D) (Cont.)			Drive Shaft (4 W/D) (Cont.)		
U-Joint (Cont.)			U-Joint (Cont.)		
2014-2008 F-150 w/ 3 Joint Shaft: [Type 14]			2007-2004 F-150 w/ 3 Joint Shaft: [Type 14]		
	U-Joint (Fr. Shaft; Frt.) [⊙]	UJ331		U-Joint (Fr. Shaft; Frt.) [⊙]	UJ354
	Brute Force Greaseable	UJ232		Brute Force Greaseable	UJ270
	Brute Force Non Greaseable	UJ231		Brute Force Non Greaseable	UJ254
	(For Aluminum Drive Shaft)	UJ331C		(For Aluminum Drive Shaft)	UJ354C
	U-Joint (Fr. Shaft; Rr.) [⊙]	UJ331		U-Joint (Fr. Shaft; Rr.) [⊙]	UJ354
	Brute Force Greaseable	UJ232		Brute Force Greaseable	UJ270
	Brute Force Non Greaseable	UJ231		Brute Force Non Greaseable	UJ254
	(For Aluminum Drive Shaft)	UJ331C		(For Aluminum Drive Shaft)	UJ354C
	U-Joint (Rr. Shaft; Frt.) [⊙]	UJ331		U-Joint (Rr. Shaft; Frt.) [⊙]	UJ331
	Brute Force Greaseable	UJ232		Brute Force Greaseable	UJ232
	Brute Force Non Greaseable	UJ231		Brute Force Non Greaseable	UJ231
	(For Aluminum Drive Shaft)	UJ331C		(For Aluminum Drive Shaft)	UJ331C
	U-Joint (Rr. Shaft; Ctr.) [⊙]	UJ331		U-Joint (Rr. Shaft; Ctr.) [⊙]	UJ331
	Brute Force Greaseable	UJ232		Brute Force Greaseable	UJ232
	Brute Force Non Greaseable	UJ231		Brute Force Non Greaseable	UJ231
	(For Aluminum Drive Shaft)	UJ331C		(For Aluminum Drive Shaft)	UJ331C
	U-Joint (Rr. Shaft; Rr.) [⊙]	UJ331		U-Joint (Rr. Shaft; Rr.) [⊙]	UJ331
	Brute Force Greaseable	UJ232		Brute Force Greaseable	UJ232
	Brute Force Non Greaseable	UJ231		Brute Force Non Greaseable	UJ231
	(For Aluminum Drive Shaft)	UJ331C		(For Aluminum Drive Shaft)	UJ331C
	2007-2004 F-150 w/ 2 Joint Shaft: [Type 13]			2007-2004 F-150 w/ Staked U-Joints: [Type 13]	
	U-Joint (Fr. Shaft; Frt.) [⊙]	UJ354		U-Joint (Fr. Shaft; Frt.) [⊙]	UJ354
	Brute Force Greaseable	UJ270		Brute Force Greaseable	UJ270
	Brute Force Non Greaseable	UJ254		Brute Force Non Greaseable	UJ254
	(For Aluminum Drive Shaft)	UJ354C		(For Aluminum Drive Shaft)	UJ354C
	U-Joint (Fr. Shaft; Rr.) [⊙]	UJ354		U-Joint (Fr. Shaft; Rr.) [⊙]	UJ354
	Brute Force Greaseable	UJ270		Brute Force Greaseable	UJ270
	Brute Force Non Greaseable	UJ254		Brute Force Non Greaseable	UJ254
	(For Aluminum Drive Shaft)	UJ354C		(For Aluminum Drive Shaft)	UJ354C
	U-Joint (Rr. Shaft; Frt.) [⊙]	UJ331		U-Joint (Rr. Shaft; Frt.) [⊙]	UJ30488
	Brute Force Greaseable	UJ232		U-Joint (Rr. Shaft; Rr.) [⊙]	UJ30488
	Brute Force Non Greaseable	UJ231		2004 F-150 Heritage w/ 4.2L & 4.6L Engs.:	
	(For Aluminum Drive Shaft)	UJ331C		[Type 13]	
	U-Joint (Rr. Shaft; Rr.) [⊙]	UJ331		U-Joint (Fr. Shaft; Frt.) [⊙]	UJ354
	Brute Force Greaseable	UJ232		Brute Force Greaseable	UJ270
	Brute Force Non Greaseable	UJ231		Brute Force Non Greaseable	UJ254
	(For Aluminum Drive Shaft)	UJ331C		(For Aluminum Drive Shaft)	UJ354C
				U-Joint (Fr. Shaft; Rr.) [⊙]	UJ354
				Brute Force Greaseable	UJ270
				Brute Force Non Greaseable	UJ254
				(For Aluminum Drive Shaft)	UJ354C
				U-Joint (Rr. Shaft; Frt.) [⊙]	[2] UJ354
				Brute Force Greaseable	UJ270
				Brute Force Non Greaseable	UJ254
				(For Aluminum Drive Shaft)	UJ354C
				U-Joint (Rr. Shaft; Rr.) [⊙]	UJ354
				Brute Force Greaseable	UJ270
				Brute Force Non Greaseable	UJ254
				(For Aluminum Drive Shaft)	UJ354C

(Continued)

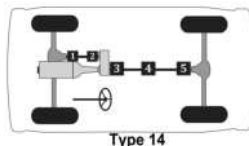
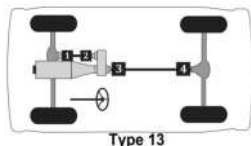

MFG./YEAR	MODEL & LOCATION	PART NO.	MFG./YEAR	MODEL & LOCATION	PART NO.
Drive Shaft (4 W/D) (Cont.)			Drive Shaft (4 W/D) (Cont.)		
U-Joint (Cont.)			U-Joint (Cont.)		
2004	F-150 Heritage w/ 5.4L Eng.: [Type 13]		2003-1997	F-150 w/ Reg. Cab, Short Bed & 5.4L Eng.: [Type 13]	
	U-Joint (Frt. Shaft; Frt.) ①	UJ354		U-Joint (Frt. Shaft; Frt.) ①	UJ354
	<i>Brute Force Greaseable</i>	UJ270		<i>Brute Force Greaseable</i>	UJ270
	<i>Brute Force Non Greaseable</i>	UJ254		<i>Brute Force Non Greaseable</i>	UJ254
	(For Aluminum Drive Shaft)	UJ354C		(For Aluminum Drive Shaft)	UJ354C
	U-Joint (Frt. Shaft; Rr.) ②	UJ354		U-Joint (Frt. Shaft; Rr.) ②	UJ354
	<i>Brute Force Greaseable</i>	UJ270		<i>Brute Force Greaseable</i>	UJ270
	<i>Brute Force Non Greaseable</i>	UJ254		<i>Brute Force Non Greaseable</i>	UJ254
	(For Aluminum Drive Shaft)	UJ354C		(For Aluminum Drive Shaft)	UJ354C
	U-Joint (Rr. Shaft; Frt.) ② [2]	UJ331		U-Joint (Rr. Shaft; Frt.) ② [2]	UJ331
	<i>Brute Force Greaseable</i>	UJ232		<i>Brute Force Greaseable</i>	UJ232
	<i>Brute Force Non Greaseable</i>	UJ231		<i>Brute Force Non Greaseable</i>	UJ231
	(For Aluminum Drive Shaft)	UJ331C		(For Aluminum Drive Shaft)	UJ331C
	U-Joint (Rr. Shaft; Rr.) ④	UJ331		U-Joint (Rr. Shaft; Rr.) ④	UJ331
	<i>Brute Force Greaseable</i>	UJ232		<i>Brute Force Greaseable</i>	UJ232
	<i>Brute Force Non Greaseable</i>	UJ231		<i>Brute Force Non Greaseable</i>	UJ231
	(For Aluminum Drive Shaft)	UJ331C		(For Aluminum Drive Shaft)	UJ331C
	2003-1997 F-150 w/ Reg. Cab, Short Bed, 4.2L & 4.6L Eng.s.: [Type 13]			2003-1997 F-150 w/ 2 Joint Shaft Exc. Reg. Cab w/ Short Bed: [Type 13]	
	U-Joint (Frt. Shaft; Frt.) ①	UJ354		U-Joint (Frt. Shaft; Frt.) ①	UJ354
	<i>Brute Force Greaseable</i>	UJ270		<i>Brute Force Greaseable</i>	UJ270
	<i>Brute Force Non Greaseable</i>	UJ254		<i>Brute Force Non Greaseable</i>	UJ254
	(For Aluminum Drive Shaft)	UJ354C		(For Aluminum Drive Shaft)	UJ354C
	U-Joint (Frt. Shaft; Rr.) ②	UJ354		U-Joint (Frt. Shaft; Rr.) ②	UJ354
	<i>Brute Force Greaseable</i>	UJ270		<i>Brute Force Greaseable</i>	UJ270
	<i>Brute Force Non Greaseable</i>	UJ254		<i>Brute Force Non Greaseable</i>	UJ254
	(For Aluminum Drive Shaft)	UJ354C		(For Aluminum Drive Shaft)	UJ354C
	U-Joint (Rr. Shaft; Frt.) ② [2]	UJ354		U-Joint (Rr. Shaft; Frt.) ②	UJ331
	<i>Brute Force Greaseable</i>	UJ270		<i>Brute Force Greaseable</i>	UJ232
	<i>Brute Force Non Greaseable</i>	UJ254		<i>Brute Force Non Greaseable</i>	UJ231
	(For Aluminum Drive Shaft)	UJ354C		(For Aluminum Drive Shaft)	UJ331C
	U-Joint (Rr. Shaft; Rr.) ④	UJ354		U-Joint (Rr. Shaft; Rr.) ④	UJ331
	<i>Brute Force Greaseable</i>	UJ270		<i>Brute Force Greaseable</i>	UJ232
	<i>Brute Force Non Greaseable</i>	UJ254		<i>Brute Force Non Greaseable</i>	UJ231
	(For Aluminum Drive Shaft)	UJ354C		(For Aluminum Drive Shaft)	UJ331C
	H Yoke	UJ648		H Yoke	UJ650

(Continued)

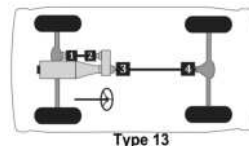

Passenger cars, light & medium trucks

Ford Truck 1/2 ton -- (Cont.)

MFG./YEAR	MODEL & LOCATION	PART NO.	MFG./YEAR	MODEL & LOCATION	PART NO.
-----------	------------------	----------	-----------	------------------	----------

Drive Shaft (4 W/D) (Cont.)

U-Joint (Cont.)

2003-1997 F-150 w/ 3 Joint Shaft Exc. Reg. Cab
w/ Short Bed: [Type 14]

U-Joint (Fr. Shaft; Frt.) [⊙]	UJ354
Brute Force Greaseable	UJ270
Brute Force Non Greaseable	UJ254
(For Aluminum Drive Shaft)	UJ354C
U-Joint (Fr. Shaft; Rr.) [⊙]	UJ354
Brute Force Greaseable	UJ270
Brute Force Non Greaseable	UJ254
(For Aluminum Drive Shaft)	UJ354C
U-Joint (Rr. Shaft; Frt.) [⊙]	UJ331
Brute Force Greaseable	UJ232
Brute Force Non Greaseable	UJ231
(For Aluminum Drive Shaft)	UJ331C
U-Joint (Rr. Shaft; Ctr.) [⊙]	UJ331
Brute Force Greaseable	UJ232
Brute Force Non Greaseable	UJ231
(For Aluminum Drive Shaft)	UJ331C
U-Joint (Rr. Shaft; Rr.) [⊙]	UJ331
Brute Force Greaseable	UJ232
Brute Force Non Greaseable	UJ231
(For Aluminum Drive Shaft)	UJ331C

Drive Shaft (4 W/D) (Cont.)

U-Joint (Cont.)

1996-1990 F-150 w/ Ext. Cab & Long Bed: [Type 36]

U-Joint (Fr. Shaft; Frt.) [⊙]	UJ434
Brute Force Greaseable	UJ265
Brute Force Non Greaseable	UJ264
U-Bolt Kit (Fr. Shaft; Frt.)	UJ534-10
U-Joint (Fr. Shaft; Rr.) [⊙]	UJ434
Brute Force Greaseable	UJ265
Brute Force Non Greaseable	UJ264
U-Bolt Kit (Fr. Shaft; Rr.)	UJ534-10
U-Joint (Rr. Shaft; Frt.) [⊙]	• UJ434
Brute Force Greaseable	UJ265
Brute Force Non Greaseable	UJ264
U-Bolt Kit (Rr. Shaft; Frt.)	UJ534-10
U-Joint (Rr. Shaft; Frt.) [⊙]	■ UJ354
Brute Force Greaseable	UJ270
Brute Force Non Greaseable	UJ254
(For Aluminum Drive Shaft)	UJ354C
U-Joint (Rr. Shaft; Rr.) [⊙]	• UJ434
Brute Force Greaseable	UJ265
Brute Force Non Greaseable	UJ264
U-Bolt Kit (Rr. Shaft; Rr.)	UJ534-10
U-Joint (Rr. Shaft; Rr.) [⊙]	■ UJ354
Brute Force Greaseable	UJ270
Brute Force Non Greaseable	UJ254
(For Aluminum Drive Shaft)	UJ354C
U-Joint (Front Axle Left Outer) [⊙]	UJ371
Brute Force Greaseable	UJ377
Brute Force Non Greaseable	UJ371
U-Joint (Front Axle Right Inner) [⊙]	UJ371
Brute Force Greaseable	UJ377
Brute Force Non Greaseable	UJ371
U-Joint (Front Axle Right Outer) [⊙]	UJ371
Brute Force Greaseable	UJ377
Brute Force Non Greaseable	UJ371

(Continued)

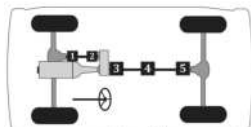

Type 14

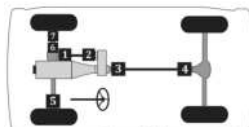

Type 36

MFG./YEAR	MODEL & LOCATION	PART NO.	MFG./YEAR	MODEL & LOCATION	PART NO.
Drive Shaft (4 W/D) (Cont.)			Drive Shaft (4 W/D) (Cont.)		
U-Joint (Cont.)			U-Joint (Cont.)		
1996-1990 F-150 Exc. Ext. Cab & Long Bed:			1989-1988 F-150 w/ 2 Joint Shaft & 5 Spd. Man. Trans. Thru 1/89: [Type 36]		
[Type 37]			[Type 36]		
U-Joint (Frnt. Shaft; Frt.) ^①		UJ434	U-Joint (Frnt. Shaft; Frt.) ^①		UJ434
Brute Force Greaseable		UJ265	Brute Force Greaseable		UJ265
Brute Force Non Greaseable		UJ264	Brute Force Non Greaseable		UJ264
U-Bolt Kit (Frnt. Shaft; Frt.)		UJ534-10	U-Bolt Kit (Frnt. Shaft; Frt.)		UJ534-10
U-Joint (Frnt. Shaft; Rr.) ^②		UJ434	U-Joint (Frnt. Shaft; Rr.) ^②		UJ434
Brute Force Greaseable		UJ265	Brute Force Greaseable		UJ265
Brute Force Non Greaseable		UJ264	Brute Force Non Greaseable		UJ264
U-Bolt Kit (Frnt. Shaft; Rr.)		UJ534-10	U-Bolt Kit (Frnt. Shaft; Rr.)		UJ534-10
U-Joint (Rr. Shaft; Frt.) ^③		• UJ434	U-Joint (Rr. Shaft; Frt.) ^③		UJ434
Brute Force Greaseable		UJ265	Brute Force Greaseable		UJ265
Brute Force Non Greaseable		UJ264	Brute Force Non Greaseable		UJ264
U-Bolt Kit (Rr. Shaft; Frt.)		UJ534-10	U-Bolt Kit (Rr. Shaft; Frt.)		UJ534-10
U-Joint (Rr. Shaft; Rr.) ^④		■ UJ354	U-Joint (Rr. Shaft; Rr.) ^④		UJ434
Brute Force Greaseable		UJ270	Brute Force Greaseable		UJ265
Brute Force Non Greaseable		UJ254	Brute Force Non Greaseable		UJ264
(For Aluminum Drive Shaft)		UJ354C	U-Bolt Kit (Rr. Shaft; Rr.)		UJ534-10
U-Joint (Rr. Shaft; Ctr.) ^⑤		UJ354	U-Joint (Front Axle Left Outer) ^⑥		UJ371
Brute Force Greaseable		UJ270	Brute Force Greaseable		UJ377
Brute Force Non Greaseable		UJ254	Brute Force Non Greaseable		UJ371
(For Aluminum Drive Shaft)		UJ354C	U-Joint (Front Axle Right Inner) ^⑦		UJ371
U-Joint (Rr. Shaft; Rr.) ^⑥		• UJ434	Brute Force Greaseable		UJ377
Brute Force Greaseable		UJ265	Brute Force Non Greaseable		UJ371
Brute Force Non Greaseable		UJ264	U-Joint (Front Axle Right Outer) ^⑧		UJ371
U-Bolt Kit (Rr. Shaft; Rr.)		UJ534-10	Brute Force Greaseable		UJ377
U-Joint (Rr. Shaft; Rr.) ^⑦		■ UJ354	Brute Force Non Greaseable		UJ371
Brute Force Greaseable		UJ270			(Continued)
Brute Force Non Greaseable		UJ254			
(For Aluminum Drive Shaft)		UJ354C			
U-Joint (Front Axle Left Outer) ^⑧		UJ371			
Brute Force Greaseable		UJ377			
Brute Force Non Greaseable		UJ371			
U-Joint (Front Axle Right Inner) ^⑨		UJ371			
Brute Force Greaseable		UJ377			
Brute Force Non Greaseable		UJ371			
U-Joint (Front Axle Right Outer) ^⑩		UJ371			
Brute Force Greaseable		UJ377			
Brute Force Non Greaseable		UJ371			

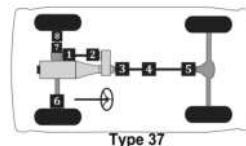
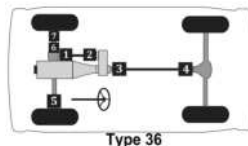

Passenger cars, light & medium trucks

Ford Truck 1/2 ton -- (Cont.)

MFG./YEAR	MODEL & LOCATION	PART NO.	MFG./YEAR	MODEL & LOCATION	PART NO.
-----------	------------------	----------	-----------	------------------	----------

Drive Shaft (4 W/D) (Cont.)

U-Joint (Cont.)

1989-1988 F-150 w/ 2 Joint Shaft Exc. 5 Spd.

Man. Trans. Thru 1/89: [Type 36]

U-Joint (Fr. Shaft; Fr.) [ⓐ]	UJ434
Brute Force Greaseable	UJ265
Brute Force Non Greaseable	UJ264
U-Bolt Kit (Fr. Shaft; Fr.)	UJ534-10
U-Joint (Fr. Shaft; Rr.) [ⓑ]	UJ434
Brute Force Greaseable	UJ265
Brute Force Non Greaseable	UJ264
U-Bolt Kit (Fr. Shaft; Rr.)	UJ534-10
U-Joint (Rr. Shaft; Fr.) [ⓐ]	UJ354
Brute Force Greaseable	UJ270
Brute Force Non Greaseable	UJ254
(For Aluminum Drive Shaft)	UJ354C
U-Joint (Rr. Shaft; Rr.) [ⓑ]	UJ434
Brute Force Greaseable	UJ265
Brute Force Non Greaseable	UJ264
U-Bolt Kit (Rr. Shaft; Rr.)	UJ534-10
U-Joint (Front Axle Left Outer) [ⓐ]	UJ371
Brute Force Greaseable	UJ377
Brute Force Non Greaseable	UJ371
U-Joint (Front Axle Right Inner) [ⓐ]	UJ371
Brute Force Greaseable	UJ377
Brute Force Non Greaseable	UJ371
U-Joint (Front Axle Right Outer) [ⓑ]	UJ371
Brute Force Greaseable	UJ377
Brute Force Non Greaseable	UJ371

Drive Shaft (4 W/D) (Cont.)

U-Joint (Cont.)

1989-1988 F-150 w/ 2 Joint Shaft From 2/89:

[Type 36]

U-Joint (Fr. Shaft; Fr.) [ⓐ]	UJ434
Brute Force Greaseable	UJ265
Brute Force Non Greaseable	UJ264
U-Bolt Kit (Fr. Shaft; Fr.)	UJ534-10
U-Joint (Fr. Shaft; Rr.) [ⓑ]	UJ434
Brute Force Greaseable	UJ265
Brute Force Non Greaseable	UJ264
U-Bolt Kit (Fr. Shaft; Rr.)	UJ534-10
U-Joint (Rr. Shaft; Fr.) [ⓐ]	UJ354
Brute Force Greaseable	UJ270
Brute Force Non Greaseable	UJ254
(For Aluminum Drive Shaft)	UJ354C
U-Joint (Rr. Shaft; Rr.) [ⓑ]	UJ354
Brute Force Greaseable	UJ270
Brute Force Non Greaseable	UJ254
(For Aluminum Drive Shaft)	UJ354C
U-Joint (Front Axle Left Outer) [ⓐ]	UJ371
Brute Force Greaseable	UJ377
Brute Force Non Greaseable	UJ371
U-Joint (Front Axle Right Inner) [ⓐ]	UJ371
Brute Force Greaseable	UJ377
Brute Force Non Greaseable	UJ371
U-Joint (Front Axle Right Outer) [ⓑ]	UJ371
Brute Force Greaseable	UJ377
Brute Force Non Greaseable	UJ371

(Continued)

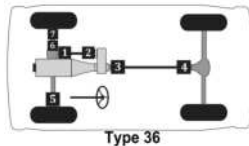

366 ▲ For Use w/ 1.063" Bearing Cap Application. ⓐ For Use w/ 1.188" Bearing Cap Application. ◇ For Use w/ Inner Lock Ring Application on Half Shaft. □ For Use w/ Outer Lock Ring Application on Half Shaft.

MFG./YEAR	MODEL & LOCATION	PART NO.	MFG./YEAR	MODEL & LOCATION	PART NO.
Drive Shaft (4 W/D) (Cont.)			Drive Shaft (4 W/D) (Cont.)		
U-Joint (Cont.)			U-Joint (Cont.)		
1989-1988 F-150 w/ 3 Joint Shaft: [Type 37]			1987 F-150 w/ 3 Joint Shaft & Part Time Transfer Case: [Type 37]		
	U-Joint (Fr. Shaft; Fr.) ❶	UJ434		U-Joint (Fr. Shaft; Fr.) ❶	UJ434
	<i>Brute Force Greaseable</i>	UJ265		<i>Brute Force Greaseable</i>	UJ265
	<i>Brute Force Non Greaseable</i>	UJ264		<i>Brute Force Non Greaseable</i>	UJ264
	U-Bolt Kit (Fr. Shaft; Fr.)	UJ534-10		U-Bolt Kit (Fr. Shaft; Fr.)	UJ534-10
	U-Joint (Fr. Shaft; Rr.) ❷	UJ434		U-Joint (Fr. Shaft; Rr.) ❷	UJ354
	<i>Brute Force Greaseable</i>	UJ265		<i>Brute Force Greaseable</i>	UJ270
	<i>Brute Force Non Greaseable</i>	UJ264		<i>Brute Force Non Greaseable</i>	UJ254
	U-Bolt Kit (Fr. Shaft; Rr.)	UJ534-10		(For Aluminum Drive Shaft)	UJ354C
	U-Joint (Rr. Shaft; Fr.) ❸	UJ354		U-Joint (Rr. Shaft; Fr.) ❸	UJ434
	<i>Brute Force Greaseable</i>	UJ270		<i>Brute Force Greaseable</i>	UJ265
	<i>Brute Force Non Greaseable</i>	UJ254		<i>Brute Force Non Greaseable</i>	UJ264
	(For Aluminum Drive Shaft)	UJ354C		U-Bolt Kit (Rr. Shaft; Fr.)	UJ534-10
	U-Joint (Rr. Shaft; Ctr.) ❹	UJ354		U-Joint (Rr. Shaft; Ctr.) ❹	UJ354
	<i>Brute Force Greaseable</i>	UJ270		<i>Brute Force Greaseable</i>	UJ270
	<i>Brute Force Non Greaseable</i>	UJ254		<i>Brute Force Non Greaseable</i>	UJ254
	(For Aluminum Drive Shaft)	UJ354C		(For Aluminum Drive Shaft)	UJ354C
	U-Joint (Rr. Shaft; Rr.) ❺	UJ434		U-Joint (Rr. Shaft; Rr.) ❺	UJ434
	<i>Brute Force Greaseable</i>	UJ265		<i>Brute Force Greaseable</i>	UJ265
	<i>Brute Force Non Greaseable</i>	UJ264		<i>Brute Force Non Greaseable</i>	UJ264
	U-Bolt Kit (Rr. Shaft; Rr.)	UJ534-10		U-Bolt Kit (Rr. Shaft; Rr.)	UJ534-10
	U-Joint (Front Axle Left Outer) ❻	UJ371		U-Joint (Front Axle Left Outer) ❻	UJ371
	<i>Brute Force Greaseable</i>	UJ377		<i>Brute Force Greaseable</i>	UJ377
	<i>Brute Force Non Greaseable</i>	UJ371		<i>Brute Force Non Greaseable</i>	UJ371
	U-Joint (Front Axle Right Inner) ❼	UJ371		U-Joint (Front Axle Right Inner) ❼	UJ371
	<i>Brute Force Greaseable</i>	UJ377		<i>Brute Force Greaseable</i>	UJ377
	<i>Brute Force Non Greaseable</i>	UJ371		<i>Brute Force Non Greaseable</i>	UJ371
	U-Joint (Front Axle Right Outer) ❽	UJ371		U-Joint (Front Axle Right Outer) ❽	UJ371
	<i>Brute Force Greaseable</i>	UJ377		<i>Brute Force Greaseable</i>	UJ377
	<i>Brute Force Non Greaseable</i>	UJ371		<i>Brute Force Non Greaseable</i>	UJ371

(Continued)

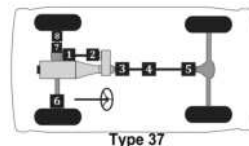

Passenger cars, light & medium trucks

Ford Truck 1/2 ton -- (Cont.)

MFG./YEAR	MODEL & LOCATION	PART NO.	MFG./YEAR	MODEL & LOCATION	PART NO.
-----------	------------------	----------	-----------	------------------	----------

Drive Shaft (4 W/D) (Cont.)

U-Joint (Cont.)

1987	F-150 w/ 3 Joint Shaft Exc. Part Time	
	Transfer Case: [Type 37]	
U-Joint (Fr. Shaft; Frt.) [ⓐ]	UJ434
Brute Force Greaseable	UJ265
Brute Force Non Greaseable	UJ264
U-Bolt Kit (Fr. Shaft; Frt.)	UJ534-10
U-Joint (Fr. Shaft; Rr.) [ⓑ]	UJ354
Brute Force Greaseable	UJ270
Brute Force Non Greaseable	UJ254
(For Aluminum Drive Shaft)	UJ354C
U-Joint (Rr. Shaft; Frt.) [ⓐ]	UJ354
Brute Force Greaseable	UJ270
Brute Force Non Greaseable	UJ254
(For Aluminum Drive Shaft)	UJ354C
U-Joint (Rr. Shaft; Ctr.) [ⓐ]	UJ354
Brute Force Greaseable	UJ270
Brute Force Non Greaseable	UJ254
(For Aluminum Drive Shaft)	UJ354C
U-Joint (Rr. Shaft; Rr.) [ⓑ]	UJ434
Brute Force Greaseable	UJ265
Brute Force Non Greaseable	UJ264
U-Bolt Kit (Rr. Shaft; Rr.)	UJ534-10
U-Joint (Front Axle Left Outer) [ⓐ]	UJ371
Brute Force Greaseable	UJ377
Brute Force Non Greaseable	UJ371
U-Joint (Front Axle Right Inner) [ⓐ]	UJ371
Brute Force Greaseable	UJ377
Brute Force Non Greaseable	UJ371
U-Joint (Front Axle Right Outer) [ⓐ]	UJ371
Brute Force Greaseable	UJ377
Brute Force Non Greaseable	UJ371

Drive Shaft (4 W/D) (Cont.)

U-Joint (Cont.)

1987-1986 F-150 w/ 2 Joint Shaft: [Type 36]	
U-Joint (Fr. Shaft; Frt.) [ⓐ]UJ434
Brute Force GreaseableUJ265
Brute Force Non GreaseableUJ264
U-Bolt Kit (Fr. Shaft; Frt.)UJ534-10
U-Joint (Fr. Shaft; Rr.) [ⓑ]UJ354
Brute Force GreaseableUJ270
Brute Force Non GreaseableUJ254
(For Aluminum Drive Shaft)UJ354C
U-Joint (Rr. Shaft; Frt.) [ⓐ]UJ354
Brute Force GreaseableUJ270
Brute Force Non GreaseableUJ254
(For Aluminum Drive Shaft)UJ354C
U-Joint (Rr. Shaft; Rr.) [ⓑ]UJ434
Brute Force GreaseableUJ265
Brute Force Non GreaseableUJ264
U-Bolt Kit (Rr. Shaft; Rr.)UJ534-10
U-Joint (Front Axle Left Outer) [ⓐ]UJ371
Brute Force GreaseableUJ377
Brute Force Non GreaseableUJ371
U-Joint (Front Axle Right Inner) [ⓐ]UJ371
Brute Force GreaseableUJ377
Brute Force Non GreaseableUJ371
U-Joint (Front Axle Right Outer) [ⓐ]UJ371
Brute Force GreaseableUJ377
Brute Force Non GreaseableUJ371

(Continued)

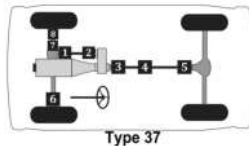
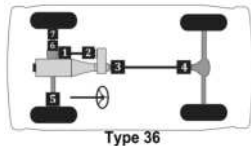

368 ▲ For Use w/ 1.063" Bearing Cap Application. ⓐ For Use w/ 1.188" Bearing Cap Application. ◇ For Use w/ Inner Lock Ring Application on Half Shaft. □ For Use w/ Outer Lock Ring Application on Half Shaft.

MFG./YEAR	MODEL & LOCATION	PART NO.	MFG./YEAR	MODEL & LOCATION	PART NO.
Drive Shaft (4 W/D) (Cont.)			Drive Shaft (4 W/D) (Cont.)		
U-Joint (Cont.)			U-Joint (Cont.)		
1986	F-150 w/ 3 Joint Shaft: [Type 37]		1985-1984	F-150 Exc. Crew Cab From 2/84:	
				[Type 36]	
	U-Joint (Frnt. Shaft; Frt.)①	UJ434		U-Joint (Frnt. Shaft; Frt.)①	UJ434
	Brute Force Greaseable	UJ265		Brute Force Greaseable	UJ265
	Brute Force Non Greaseable	UJ264		Brute Force Non Greaseable	UJ264
	U-Bolt Kit (Frnt. Shaft; Frt.)	UJ534-10		U-Bolt Kit (Frnt. Shaft; Frt.)	UJ534-10
	U-Joint (Frnt. Shaft; Rr.)②	UJ354		U-Joint (Frnt. Shaft; Rr.)②	UJ434
	Brute Force Greaseable	UJ270		Brute Force Greaseable	UJ265
	Brute Force Non Greaseable	UJ254		Brute Force Non Greaseable	UJ264
	(For Aluminum Drive Shaft)	UJ354C		U-Bolt Kit (Frnt. Shaft; Rr.)	UJ534-10
	U-Joint (Rr. Shaft; Frt.)③	UJ354		U-Joint (Rr. Shaft; Frt.)③	UJ354
	Brute Force Greaseable	UJ270		Brute Force Greaseable	UJ270
	Brute Force Non Greaseable	UJ254		Brute Force Non Greaseable	UJ254
	(For Aluminum Drive Shaft)	UJ354C		(For Aluminum Drive Shaft)	UJ354C
	U-Joint (Rr. Shaft; Ctr.)④	UJ354		U-Joint (Rr. Shaft; Rr.)④	UJ434
	Brute Force Greaseable	UJ270		Brute Force Greaseable	UJ265
	Brute Force Non Greaseable	UJ254		Brute Force Non Greaseable	UJ264
	(For Aluminum Drive Shaft)	UJ354C		U-Bolt Kit (Rr. Shaft; Rr.)	UJ534-10
	U-Joint (Rr. Shaft; Rr.)⑤	UJ434		U-Joint (Front Axle Left Outer)⑥	UJ371
	Brute Force Greaseable	UJ265		Brute Force Greaseable	UJ377
	Brute Force Non Greaseable	UJ264		Brute Force Non Greaseable	UJ371
	U-Bolt Kit (Rr. Shaft; Rr.)	UJ534-10		U-Joint (Front Axle Right Inner)⑦	UJ371
	U-Joint (Front Axle Left Outer)⑥	UJ371		Brute Force Greaseable	UJ377
	Brute Force Greaseable	UJ377		Brute Force Non Greaseable	UJ371
	Brute Force Non Greaseable	UJ371		U-Joint (Front Axle Right Outer)⑧	UJ371
	U-Joint (Front Axle Right Inner)⑦	UJ371		Brute Force Greaseable	UJ377
	Brute Force Greaseable	UJ377		Brute Force Non Greaseable	UJ371
	Brute Force Non Greaseable	UJ371			
	U-Joint (Front Axle Right Outer)⑧	UJ371			
	Brute Force Greaseable	UJ377			
	Brute Force Non Greaseable	UJ371			

(Continued)

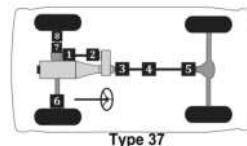
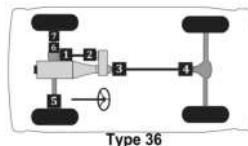

Passenger cars, light & medium trucks

Ford Truck 1/2 ton -- (Cont.)

MFG./YEAR	MODEL & LOCATION	PART NO.	MFG./YEAR	MODEL & LOCATION	PART NO.
Drive Shaft (4 W/D) (Cont.)			Drive Shaft (4 W/D) (Cont.)		
U-Joint (Cont.)			U-Joint (Cont.)		
1985-1982 F-150 w/ Crew Cab: [Type 37]			1984-1982 F-150 Exc. Crew Cab Thru 1/84:		
[Type 37]			[Type 36]		
U-Joint (Fr. Shaft; Frt.) ^①		UJ434	U-Joint (Fr. Shaft; Frt.) ^①		UJ434
Brute Force Greaseable		UJ265	Brute Force Greaseable		UJ265
Brute Force Non Greaseable		UJ264	Brute Force Non Greaseable		UJ264
U-Bolt Kit (Fr. Shaft; Frt.)		UJ534-10	U-Bolt Kit (Fr. Shaft; Frt.)		UJ534-10
U-Joint (Fr. Shaft; Rr.) ^②		UJ434	U-Joint (Fr. Shaft; Rr.) ^②		UJ434
Brute Force Greaseable		UJ265	Brute Force Greaseable		UJ265
Brute Force Non Greaseable		UJ264	Brute Force Non Greaseable		UJ264
U-Bolt Kit (Fr. Shaft; Rr.)		UJ534-10	U-Bolt Kit (Fr. Shaft; Rr.)		UJ534-10
U-Joint (Rr. Shaft; Frt.) ^③		UJ434	U-Joint (Rr. Shaft; Frt.) ^③		UJ434
Brute Force Greaseable		UJ265	Brute Force Greaseable		UJ265
Brute Force Non Greaseable		UJ264	Brute Force Non Greaseable		UJ264
U-Bolt Kit (Rr. Shaft; Frt.)		UJ534-10	U-Bolt Kit (Rr. Shaft; Frt.)		UJ534-10
U-Joint (Rr. Shaft; Ctr.) ^④		UJ354	U-Joint (Rr. Shaft; Rr.) ^④		UJ434
Brute Force Greaseable		UJ270	Brute Force Greaseable		UJ265
Brute Force Non Greaseable		UJ254	Brute Force Non Greaseable		UJ264
(For Aluminum Drive Shaft)		UJ354C	U-Bolt Kit (Rr. Shaft; Rr.)		UJ534-10
U-Joint (Rr. Shaft; Rr.) ^⑤		UJ434	U-Joint (Front Axle Left Outer) ^⑥		UJ371
Brute Force Greaseable		UJ265	Brute Force Greaseable		UJ377
Brute Force Non Greaseable		UJ264	Brute Force Non Greaseable		UJ371
U-Bolt Kit (Rr. Shaft; Rr.)		UJ534-10	U-Joint (Front Axle Right Inner) ^⑦		UJ371
U-Joint (Front Axle Left Outer) ^⑥		UJ371	Brute Force Greaseable		UJ377
Brute Force Greaseable		UJ377	Brute Force Non Greaseable		UJ371
Brute Force Non Greaseable		UJ371	U-Joint (Front Axle Right Outer) ^⑧		UJ371
U-Joint (Front Axle Right Inner) ^⑦		UJ371	Brute Force Greaseable		UJ377
Brute Force Greaseable		UJ377	Brute Force Non Greaseable		UJ371
Brute Force Non Greaseable		UJ371			
U-Joint (Front Axle Right Outer) ^⑧		UJ371			
Brute Force Greaseable		UJ377			
Brute Force Non Greaseable		UJ371			

(Continued)

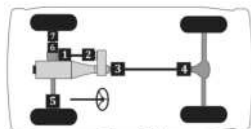

Type 36

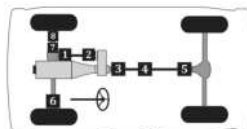

Type 37

370 ▲ For Use w/ 1.063" Bearing Cap Application. Ⓞ For Use w/ 1.188" Bearing Cap Application. ◇ For Use w/ Inner Lock Ring Application on Half Shaft. □ For Use w/ Outer Lock Ring Application on Half Shaft.

MFG./YEAR	MODEL & LOCATION	PART NO.	MFG./YEAR	MODEL & LOCATION	PART NO.
Drive Shaft (4 W/D) (Cont.)			Drive Shaft (4 W/D) (Cont.)		
U-Joint (Cont.)			U-Joint (Cont.)		
1981-1980 F-150 w/ Crew Cab & Auto. Trans.			1981-1980 F-150 w/ Crew Cab & Man. Trans.		
From Ser. GJ0,001: [Type 37]			From Ser. GJ0,001: [Type 37]		
	U-Joint (Fr. Shaft; Fr.) ^①	UJ354		U-Joint (Fr. Shaft; Fr.) ^①	UJ354
	Brute Force Greaseable	UJ270		Brute Force Greaseable	UJ270
	Brute Force Non Greaseable	UJ254		Brute Force Non Greaseable	UJ254
	(For Aluminum Drive Shaft)	UJ354C		(For Aluminum Drive Shaft)	UJ354C
	U-Joint (Fr. Shaft; Rr.) ^②	UJ434		U-Joint (Fr. Shaft; Rr.) ^②	UJ434
	Brute Force Greaseable	UJ265		Brute Force Greaseable	UJ265
	Brute Force Non Greaseable	UJ264		Brute Force Non Greaseable	UJ264
	U-Bolt Kit (Fr. Shaft; Rr.)	UJ534-10		U-Bolt Kit (Fr. Shaft; Rr.)	UJ534-10
	U-Joint (Rr. Shaft; Fr.) ^③	UJ354		U-Joint (Rr. Shaft; Fr.) ^③	UJ354
	Brute Force Greaseable	UJ270		Brute Force Greaseable	UJ270
	Brute Force Non Greaseable	UJ254		Brute Force Non Greaseable	UJ254
	(For Aluminum Drive Shaft)	UJ354C		(For Aluminum Drive Shaft)	UJ354C
	U-Joint (Rr. Shaft; Ctr.) ^④	UJ354		U-Joint (Rr. Shaft; Ctr.) ^④	UJ434
	Brute Force Greaseable	UJ270		Brute Force Greaseable	UJ265
	Brute Force Non Greaseable	UJ254		Brute Force Non Greaseable	UJ264
	(For Aluminum Drive Shaft)	UJ354C		U-Bolt Kit (Rr. Shaft; Ctr.)	UJ534-10
	U-Joint (Rr. Shaft; Rr.) ^⑤	UJ434		U-Joint (Rr. Shaft; Rr.) ^⑤	UJ434
	Brute Force Greaseable	UJ265		Brute Force Greaseable	UJ265
	Brute Force Non Greaseable	UJ264		Brute Force Non Greaseable	UJ264
	U-Bolt Kit (Rr. Shaft; Rr.)	UJ534-10		U-Bolt Kit (Rr. Shaft; Rr.)	UJ534-10
	U-Joint (Front Axle Left Outer) ^⑥	UJ371		U-Joint (Front Axle Left Outer) ^⑥	UJ371
	Brute Force Greaseable	UJ377		Brute Force Greaseable	UJ377
	Brute Force Non Greaseable	UJ371		Brute Force Non Greaseable	UJ371
	U-Joint (Front Axle Right Inner) ^⑦	UJ371		U-Joint (Front Axle Right Inner) ^⑦	UJ371
	Brute Force Greaseable	UJ377		Brute Force Greaseable	UJ377
	Brute Force Non Greaseable	UJ371		Brute Force Non Greaseable	UJ371
	U-Joint (Front Axle Right Outer) ^⑧	UJ371		U-Joint (Front Axle Right Outer) ^⑧	UJ371
	Brute Force Greaseable	UJ377		Brute Force Greaseable	UJ377
	Brute Force Non Greaseable	UJ371		Brute Force Non Greaseable	UJ371

(Continued)

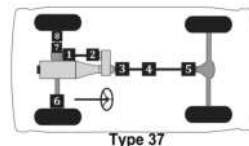

Passenger cars, light & medium trucks

Ford Truck 1/2 ton -- (Cont.)

MFG./YEAR	MODEL & LOCATION	PART NO.	MFG./YEAR	MODEL & LOCATION	PART NO.
-----------	------------------	----------	-----------	------------------	----------

Drive Shaft (4 W/D) (Cont.)

U-Joint (Cont.)

1981-1980 F-150 Exc. Crew Cab From Ser.

GJ0,001: [Type 36]

U-Joint (Fr. Shaft; Fr.) [⊙]	UJ354
Brute Force Greaseable	UJ270
Brute Force Non Greaseable	UJ254
(For Aluminum Drive Shaft)	UJ354C
U-Joint (Fr. Shaft; Rr.) [⊙]	UJ434
Brute Force Greaseable	UJ265
Brute Force Non Greaseable	UJ264
U-Bolt Kit (Fr. Shaft; Rr.)	UJ534-10
U-Joint (Rr. Shaft; Fr.) [⊙]	UJ354
Brute Force Greaseable	UJ270
Brute Force Non Greaseable	UJ254
(For Aluminum Drive Shaft)	UJ354C
U-Joint (Rr. Shaft; Rr.) [⊙]	UJ434
Brute Force Greaseable	UJ265
Brute Force Non Greaseable	UJ264
U-Bolt Kit (Rr. Shaft; Rr.)	UJ534-10
U-Joint (Front Axle Left Outer) [⊙]	UJ371
Brute Force Greaseable	UJ377
Brute Force Non Greaseable	UJ371
U-Joint (Front Axle Right Inner) [⊙]	UJ371
Brute Force Greaseable	UJ377
Brute Force Non Greaseable	UJ371
U-Joint (Front Axle Right Outer) [⊙]	UJ371
Brute Force Greaseable	UJ377
Brute Force Non Greaseable	UJ371

Drive Shaft (4 W/D) (Cont.)

U-Joint (Cont.)

1981-1980 F-150 w/ Crew Cab & Auto. Trans.

Thru Ser. GJ0,000: [Type 37]

U-Joint (Fr. Shaft; Fr.) [⊙]	UJ434
Brute Force Greaseable	UJ265
Brute Force Non Greaseable	UJ264
U-Bolt Kit (Fr. Shaft; Fr.)	UJ534-10
U-Joint (Fr. Shaft; Rr.) [⊙]	UJ354
Brute Force Greaseable	UJ270
Brute Force Non Greaseable	UJ254
(For Aluminum Drive Shaft)	UJ354C
U-Joint (Rr. Shaft; Fr.) [⊙]	UJ354
Brute Force Greaseable	UJ270
Brute Force Non Greaseable	UJ254
(For Aluminum Drive Shaft)	UJ354C
U-Joint (Rr. Shaft; Ctr.) [⊙]	UJ354
Brute Force Greaseable	UJ270
Brute Force Non Greaseable	UJ254
(For Aluminum Drive Shaft)	UJ354C
U-Joint (Rr. Shaft; Rr.) [⊙]	UJ434
Brute Force Greaseable	UJ265
Brute Force Non Greaseable	UJ264
U-Bolt Kit (Rr. Shaft; Rr.)	UJ534-10
U-Joint (Front Axle Left Outer) [⊙]	UJ371
Brute Force Greaseable	UJ377
Brute Force Non Greaseable	UJ371
U-Joint (Front Axle Right Inner) [⊙]	UJ371
Brute Force Greaseable	UJ377
Brute Force Non Greaseable	UJ371
U-Joint (Front Axle Right Outer) [⊙]	UJ371
Brute Force Greaseable	UJ377
Brute Force Non Greaseable	UJ371

(Continued)

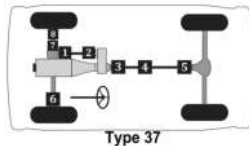
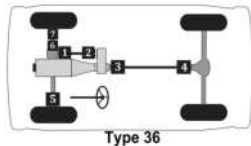

372 ▲ For Use w/ 1.063" Bearing Cap Application. ⊙ For Use w/ 1.188" Bearing Cap Application. ◇ For Use w/ Inner Lock Ring Application on Half Shaft. □ For Use w/ Outer Lock Ring Application on Half Shaft.

MFG./YEAR	MODEL & LOCATION	PART NO.	MFG./YEAR	MODEL & LOCATION	PART NO.
Drive Shaft (4 W/D) (Cont.)			Drive Shaft (4 W/D) (Cont.)		
U-Joint (Cont.)			U-Joint (Cont.)		
1981-1980 F-150 w/ Crew Cab & Man. Trans. Thru Ser. GJ0,000: [Type 37]			1981-1980 F-150 Exc. Crew Cab Thru Ser. GJ0,000: [Type 36]		
	U-Joint (Fr. Shaft; Fr.) ^①	UJ434		U-Joint (Fr. Shaft; Fr.) ^①	UJ434
	Brute Force Greaseable	UJ265		Brute Force Greaseable	UJ265
	Brute Force Non Greaseable	UJ264		Brute Force Non Greaseable	UJ264
	U-Bolt Kit (Fr. Shaft; Fr.)	UJ534-10		U-Bolt Kit (Fr. Shaft; Fr.)	UJ534-10
	U-Joint (Fr. Shaft; Rr.) ^②	UJ354		U-Joint (Fr. Shaft; Rr.) ^②	UJ354
	Brute Force Greaseable	UJ270		Brute Force Greaseable	UJ270
	Brute Force Non Greaseable	UJ254		Brute Force Non Greaseable	UJ254
	(For Aluminum Drive Shaft)	UJ354C		(For Aluminum Drive Shaft)	UJ354C
	U-Joint (Rr. Shaft; Fr.) ^③	UJ354		U-Joint (Rr. Shaft; Fr.) ^③	UJ354
	Brute Force Greaseable	UJ270		Brute Force Greaseable	UJ270
	Brute Force Non Greaseable	UJ254		Brute Force Non Greaseable	UJ254
	(For Aluminum Drive Shaft)	UJ354C		(For Aluminum Drive Shaft)	UJ354C
	U-Joint (Rr. Shaft; Ctr.) ^④	UJ434		U-Joint (Rr. Shaft; Rr.) ^⑤	UJ434
	Brute Force Greaseable	UJ265		Brute Force Greaseable	UJ265
	Brute Force Non Greaseable	UJ264		Brute Force Non Greaseable	UJ264
	U-Bolt Kit (Rr. Shaft; Ctr.)	UJ534-10		U-Bolt Kit (Rr. Shaft; Rr.)	UJ534-10
	U-Joint (Rr. Shaft; Rr.) ^⑥	UJ434		U-Joint (Front Axle Left Outer) ^⑥	UJ371
	Brute Force Greaseable	UJ265		Brute Force Greaseable	UJ377
	Brute Force Non Greaseable	UJ264		Brute Force Non Greaseable	UJ371
	U-Bolt Kit (Rr. Shaft; Rr.)	UJ534-10		U-Joint (Front Axle Right Inner) ^⑥	UJ371
	U-Joint (Front Axle Left Outer) ^⑥	UJ371		Brute Force Greaseable	UJ377
	Brute Force Greaseable	UJ377		Brute Force Non Greaseable	UJ371
	Brute Force Non Greaseable	UJ371		U-Joint (Front Axle Right Outer) ^⑥	UJ371
	U-Joint (Front Axle Right Inner) ^⑦	UJ371		Brute Force Greaseable	UJ377
	Brute Force Greaseable	UJ377		Brute Force Non Greaseable	UJ371
	Brute Force Non Greaseable	UJ371			
	U-Joint (Front Axle Right Outer) ^⑧	UJ371			
	Brute Force Greaseable	UJ377			
	Brute Force Non Greaseable	UJ371			

(Continued)

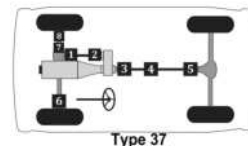
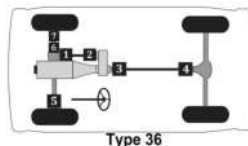

Passenger cars, light & medium trucks

Ford Truck 1/2 ton -- (Cont.)

MFG./YEAR	MODEL & LOCATION	PART NO.	MFG./YEAR	MODEL & LOCATION	PART NO.
Drive Shaft (4 W/D) (Cont.)			Drive Shaft (4 W/D) (Cont.)		
U-Joint (Cont.)			U-Joint (Cont.)		
1979	F-150 w/ 116" Wheel Base & Full Time		1979	F-150 w/ 133" Wheel Base & Full Time	
	Transfer Case: [Type 26]			Transfer Case: [Type 26]	
U-Joint (Fr. Shaft; Frt.) [⊙]		UJ354	U-Joint (Fr. Shaft; Frt.) [⊙]		UJ354
Brute Force Greaseable		UJ270	Brute Force Greaseable		UJ270
Brute Force Non Greaseable		UJ254	Brute Force Non Greaseable		UJ254
(For Aluminum Drive Shaft)		UJ354C	(For Aluminum Drive Shaft)		UJ354C
U-Joint (Fr. Shaft; Rr.) [⊙]	[2]	UJ354	U-Joint (Fr. Shaft; Rr.) [⊙]	[2]	UJ354
Brute Force Greaseable		UJ270	Brute Force Greaseable		UJ270
Brute Force Non Greaseable		UJ254	Brute Force Non Greaseable		UJ254
(For Aluminum Drive Shaft)		UJ354C	(For Aluminum Drive Shaft)		UJ354C
U-Joint (Rr. Shaft; Frt.) [⊙]	[2]	UJ354	U-Joint (Rr. Shaft; Frt.) [⊙]		UJ354
Brute Force Greaseable		UJ270	Brute Force Greaseable		UJ270
Brute Force Non Greaseable		UJ254	Brute Force Non Greaseable		UJ254
(For Aluminum Drive Shaft)		UJ354C	(For Aluminum Drive Shaft)		UJ354C
U-Joint (Rr. Shaft; Rr.) [⊙]		UJ434	U-Joint (Rr. Shaft; Rr.) [⊙]		UJ434
Brute Force Greaseable		UJ265	Brute Force Greaseable		UJ265
Brute Force Non Greaseable		UJ264	Brute Force Non Greaseable		UJ264
(For Aluminum Drive Shaft)		UJ354C	(For Aluminum Drive Shaft)		UJ354C
U-Bolt Kit (Rr. Shaft; Rr.)		UJ534-10	U-Bolt Kit (Rr. Shaft; Rr.)		UJ534-10
U-Joint (Wheel Joint) [⊙]	[2]	UJ371	U-Joint (Wheel Joint) [⊙]	[2]	UJ371
Brute Force Greaseable		UJ377	Brute Force Greaseable		UJ377
Brute Force Non Greaseable		UJ371	Brute Force Non Greaseable		UJ371
Centering Yoke		UJ608	Centering Yoke		UJ608
Weld Yoke		UJ638	Weld Yoke		UJ638
H Yoke		UJ648	H Yoke		UJ648
1979	F-150 w/ 116" Wheel Base & Part Time		1979	F-150 w/ 133" Wheel Base & Part Time	
	Transfer Case: [Type 26]			Transfer Case: [Type 26]	
U-Joint (Fr. Shaft; Frt.) [⊙]		UJ354	U-Joint (Fr. Shaft; Frt.) [⊙]		UJ354
Brute Force Greaseable		UJ270	Brute Force Greaseable		UJ270
Brute Force Non Greaseable		UJ254	Brute Force Non Greaseable		UJ254
(For Aluminum Drive Shaft)		UJ354C	(For Aluminum Drive Shaft)		UJ354C
U-Joint (Fr. Shaft; Rr.) [⊙]		UJ354	U-Joint (Fr. Shaft; Rr.) [⊙]		UJ354
Brute Force Greaseable		UJ270	Brute Force Greaseable		UJ270
Brute Force Non Greaseable		UJ254	Brute Force Non Greaseable		UJ254
(For Aluminum Drive Shaft)		UJ354C	(For Aluminum Drive Shaft)		UJ354C
U-Joint (Rr. Shaft; Frt.) [⊙]	[2]	UJ354	U-Joint (Rr. Shaft; Frt.) [⊙]		UJ354
Brute Force Greaseable		UJ270	Brute Force Greaseable		UJ270
Brute Force Non Greaseable		UJ254	Brute Force Non Greaseable		UJ254
(For Aluminum Drive Shaft)		UJ354C	(For Aluminum Drive Shaft)		UJ354C
U-Joint (Rr. Shaft; Rr.) [⊙]		UJ434	U-Joint (Rr. Shaft; Rr.) [⊙]		UJ434
Brute Force Greaseable		UJ265	Brute Force Greaseable		UJ265
Brute Force Non Greaseable		UJ264	Brute Force Non Greaseable		UJ264
(For Aluminum Drive Shaft)		UJ354C	(For Aluminum Drive Shaft)		UJ354C
U-Bolt Kit (Rr. Shaft; Rr.)		UJ534-10	U-Bolt Kit (Rr. Shaft; Rr.)		UJ534-10
U-Joint (Wheel Joint) [⊙]	[2]	UJ371	U-Joint (Wheel Joint) [⊙]	[2]	UJ371
Brute Force Greaseable		UJ377	Brute Force Greaseable		UJ377
Brute Force Non Greaseable		UJ371	Brute Force Non Greaseable		UJ371
Centering Yoke		UJ608	Centering Yoke		UJ608
Weld Yoke		UJ638			
H Yoke		UJ648			

(Continued)

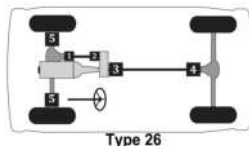

374 ▲ For Use w/ 1.063" Bearing Cap Application. ⊙ For Use w/ 1.188" Bearing Cap Application. ◇ For Use w/ Inner Lock Ring Application on Half Shaft. □ For Use w/ Outer Lock Ring Application on Half Shaft.

MFG./YEAR	MODEL & LOCATION	PART NO.	MFG./YEAR	MODEL & LOCATION	PART NO.
Drive Shaft (4 W/D) (Cont.)			Drive Shaft (4 W/D) (Cont.)		
U-Joint (Cont.)			U-Joint (Cont.)		
1979	F-150 w/ 155" Wheel Base & Full Time Transfer Case: [Type 27]		1979	F-150 w/ 155" Wheel Base & Part Time Transfer Case: [Type 27]	
	U-Joint (Frnt. Shaft; Frt.) ①	UJ354		U-Joint (Frnt. Shaft; Frt.) ①	UJ354
	Brute Force Greaseable	UJ270		Brute Force Greaseable	UJ270
	Brute Force Non Greaseable	UJ254		Brute Force Non Greaseable	UJ254
	(For Aluminum Drive Shaft)	UJ354C		(For Aluminum Drive Shaft)	UJ354C
	U-Joint (Frnt. Shaft; Rr.) ②	[2] UJ354		U-Joint (Frnt. Shaft; Rr.) ②	UJ354
	Brute Force Greaseable	UJ270		Brute Force Greaseable	UJ270
	Brute Force Non Greaseable	UJ254		Brute Force Non Greaseable	UJ254
	(For Aluminum Drive Shaft)	UJ354C		(For Aluminum Drive Shaft)	UJ354C
	U-Joint (Rr. Shaft; Frt.) ③	UJ354		U-Joint (Rr. Shaft; Frt.) ③	UJ354
	Brute Force Greaseable	UJ270		Brute Force Greaseable	UJ270
	Brute Force Non Greaseable	UJ254		Brute Force Non Greaseable	UJ254
	(For Aluminum Drive Shaft)	UJ354C		(For Aluminum Drive Shaft)	UJ354C
	U-Joint (Rr. Shaft; Ctr.) ④	UJ354		U-Joint (Rr. Shaft; Ctr.) ④	UJ354
	Brute Force Greaseable	UJ270		Brute Force Greaseable	UJ270
	Brute Force Non Greaseable	UJ254		Brute Force Non Greaseable	UJ254
	(For Aluminum Drive Shaft)	UJ354C		(For Aluminum Drive Shaft)	UJ354C
	U-Joint (Rr. Shaft; Rr.) ⑤	UJ434		U-Joint (Rr. Shaft; Rr.) ⑤	UJ434
	Brute Force Greaseable	UJ265		Brute Force Greaseable	UJ265
	Brute Force Non Greaseable	UJ264		Brute Force Non Greaseable	UJ264
	U-Bolt Kit (Rr. Shaft; Rr.)	UJ534-10		U-Bolt Kit (Rr. Shaft; Rr.)	UJ534-10
	U-Joint (Wheel Joint) ⑥	[2] UJ371		U-Joint (Wheel Joint) ⑥	[2] UJ371
	Brute Force Greaseable	UJ377		Brute Force Greaseable	UJ377
	Brute Force Non Greaseable	UJ371		Brute Force Non Greaseable	UJ371
	Centering Yoke	UJ608		Centering Yoke	UJ608
	Weld Yoke	UJ638			
	H Yoke	UJ648			
			1978	F-150 w/ 2 Joint Shaft, 3.5" Yoke & Full Time Transfer Case: [Type 26]	
				U-Joint (Frnt. Shaft; Frt.) ①	UJ369
				Brute Force Greaseable	UJ280
				Brute Force Non Greaseable	UJ269
				(For Aluminum Drive Shaft)	UJ369C
				U-Joint (Frnt. Shaft; Rr.) ②	[2] UJ379
				Brute Force Greaseable	UJ280
				Brute Force Non Greaseable	UJ269
				U-Joint (Rr. Shaft; Frt.) ③	UJ369
				Brute Force Greaseable	UJ280
				Brute Force Non Greaseable	UJ269
				(For Aluminum Drive Shaft)	UJ369C
				U-Joint (Rr. Shaft; Rr.) ④	UJ369
				Brute Force Greaseable	UJ280
				Brute Force Non Greaseable	UJ269
				(For Aluminum Drive Shaft)	UJ369C
				U-Joint (Wheel Joint) ⑤	[2] UJ371
				Brute Force Greaseable	UJ377
				Brute Force Non Greaseable	UJ371
				Weld Yoke	UJ633
				H Yoke	UJ647

(Continued)

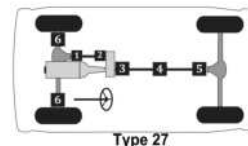
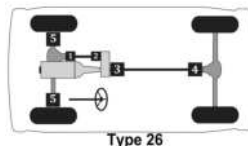

Passenger cars, light & medium trucks

Ford Truck 1/2 ton -- (Cont.)

MFG./YEAR	MODEL & LOCATION	PART NO.	MFG./YEAR	MODEL & LOCATION	PART NO.
Drive Shaft (4 W/D) (Cont.)			Drive Shaft (4 W/D) (Cont.)		
U-Joint (Cont.)			U-Joint (Cont.)		
1978	F-150 w/ 2 Joint Shaft, 3.5" Yoke & Part Time Transfer Case: [Type 26]		1978	F-150 w/ 2 Joint Shaft, 3.875" Yoke & Part Time Transfer Case: [Type 26]	
	U-Joint (Fr. Shaft; Frt.)⊙	UJ369		U-Joint (Fr. Shaft; Frt.)⊙	UJ354
	Brute Force Greaseable	UJ280		Brute Force Greaseable	UJ270
	Brute Force Non Greaseable	UJ269		Brute Force Non Greaseable	UJ254
	(For Aluminum Drive Shaft)	UJ369C		(For Aluminum Drive Shaft)	UJ354C
	U-Joint (Fr. Shaft; Rr.)⊙	UJ369		U-Joint (Fr. Shaft; Rr.)⊙	UJ354
	Brute Force Greaseable	UJ280		Brute Force Greaseable	UJ270
	Brute Force Non Greaseable	UJ269		Brute Force Non Greaseable	UJ254
	(For Aluminum Drive Shaft)	UJ369C		(For Aluminum Drive Shaft)	UJ354C
	U-Joint (Rr. Shaft; Frt.)⊙	UJ369		U-Joint (Rr. Shaft; Frt.)⊙	UJ369
	Brute Force Greaseable	UJ280		Brute Force Greaseable	UJ280
	Brute Force Non Greaseable	UJ269		Brute Force Non Greaseable	UJ269
	(For Aluminum Drive Shaft)	UJ369C		(For Aluminum Drive Shaft)	UJ369C
	U-Joint (Rr. Shaft; Rr.)⊙	UJ354		U-Joint (Rr. Shaft; Rr.)⊙	UJ354
	Brute Force Greaseable	UJ270		Brute Force Greaseable	UJ270
	Brute Force Non Greaseable	UJ254		Brute Force Non Greaseable	UJ254
	(For Aluminum Drive Shaft)	UJ354C		(For Aluminum Drive Shaft)	UJ354C
	U-Joint (Wheel Joint)⊙	[2] UJ371		U-Joint (Wheel Joint)⊙	[2] UJ371
	Brute Force Greaseable	UJ377		Brute Force Greaseable	UJ377
	Brute Force Non Greaseable	UJ371		Brute Force Non Greaseable	UJ371
	H Yoke	UJ647		Centering Yoke	UJ607
				H Yoke	UJ647
1978	F-150 w/ 2 Joint Shaft, 3.875" Yoke & Full Time Transfer Case: [Type 26]		1978	F-150 w/ 3 Joint Shaft, 3.5" Yoke & Full Time Transfer Case: [Type 26]	
	U-Joint (Fr. Shaft; Frt.)⊙	UJ354		U-Joint (Fr. Shaft; Frt.)⊙	UJ369
	Brute Force Greaseable	UJ270		Brute Force Greaseable	UJ280
	Brute Force Non Greaseable	UJ254		Brute Force Non Greaseable	UJ269
	(For Aluminum Drive Shaft)	UJ354C		(For Aluminum Drive Shaft)	UJ369C
	U-Joint (Fr. Shaft; Rr.)⊙	[2] UJ379		U-Joint (Fr. Shaft; Rr.)⊙	[2] UJ379
	Brute Force Greaseable	UJ280		Brute Force Greaseable	UJ280
	Brute Force Non Greaseable	UJ269		Brute Force Non Greaseable	UJ269
	U-Joint (Rr. Shaft; Frt.)⊙	UJ354		U-Joint (Rr. Shaft; Frt.)⊙	[2] UJ369
	Brute Force Greaseable	UJ270		Brute Force Greaseable	UJ280
	Brute Force Non Greaseable	UJ254		Brute Force Non Greaseable	UJ269
	(For Aluminum Drive Shaft)	UJ354C		Brute Force Non Greaseable	UJ369C
	U-Joint (Rr. Shaft; Rr.)⊙	UJ354		U-Joint (Rr. Shaft; Rr.)⊙	UJ369
	Brute Force Greaseable	UJ270		Brute Force Greaseable	UJ280
	Brute Force Non Greaseable	UJ254		Brute Force Non Greaseable	UJ269
	(For Aluminum Drive Shaft)	UJ354C		(For Aluminum Drive Shaft)	UJ369C
	U-Joint (Wheel Joint)⊙	[2] UJ371		U-Joint (Wheel Joint)⊙	[2] UJ371
	Brute Force Greaseable	UJ377		Brute Force Greaseable	UJ377
	Brute Force Non Greaseable	UJ371		Brute Force Non Greaseable	UJ371
	Centering Yoke	UJ607		Centering Yoke	UJ607
	H Yoke	UJ647		Weld Yoke	UJ633
				H Yoke	UJ647

(Continued)

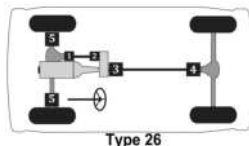

MFG./YEAR	MODEL & LOCATION	PART NO.	MFG./YEAR	MODEL & LOCATION	PART NO.
Drive Shaft (4 W/D) (Cont.)			Drive Shaft (4 W/D) (Cont.)		
U-Joint (Cont.)			U-Joint (Cont.)		
1978	F-150 w/ 3 Joint Shaft, 3.5" Yoke & Part Time Transfer Case: [Type 26]		1978	F-150 w/ 3 Joint Shaft, 3.875" Yoke & Part Time Transfer Case: [Type 26]	
	U-Joint (Frnt. Shaft; Frnt.)ⓐ	UJ369		U-Joint (Frnt. Shaft; Frnt.)ⓐ	UJ354
	Brute Force Greaseable	UJ280		Brute Force Greaseable	UJ270
	Brute Force Non Greaseable	UJ269		Brute Force Non Greaseable	UJ254
	(For Aluminum Drive Shaft)	UJ369C		(For Aluminum Drive Shaft)	UJ354C
	U-Joint (Rr. Shaft; Rr.)ⓑ	UJ369		U-Joint (Rr. Shaft; Rr.)ⓑ	UJ354
	Brute Force Greaseable	UJ280		Brute Force Greaseable	UJ270
	Brute Force Non Greaseable	UJ269		Brute Force Non Greaseable	UJ254
	(For Aluminum Drive Shaft)	UJ369C		(For Aluminum Drive Shaft)	UJ354C
	U-Joint (Rr. Shaft; Frnt.)ⓐ	[2] UJ379		U-Joint (Rr. Shaft; Frnt.)ⓐ	[2] UJ379
	Brute Force Greaseable	UJ280		Brute Force Greaseable	UJ280
	Brute Force Non Greaseable	UJ269		Brute Force Non Greaseable	UJ269
	U-Joint (Rr. Shaft; Rr.)ⓑ	UJ354		U-Joint (Rr. Shaft; Rr.)ⓑ	UJ354
	Brute Force Greaseable	UJ270		Brute Force Greaseable	UJ270
	Brute Force Non Greaseable	UJ254		Brute Force Non Greaseable	UJ254
	(For Aluminum Drive Shaft)	UJ354C		(For Aluminum Drive Shaft)	UJ354C
	U-Joint (Wheel Joint)ⓐ	[2] UJ371		U-Joint (Wheel Joint)ⓐ	[2] UJ371
	Brute Force Greaseable	UJ377		Brute Force Greaseable	UJ377
	Brute Force Non Greaseable	UJ371		Brute Force Non Greaseable	UJ371
	Centering Yoke	UJ607		Centering Yoke	UJ607
	H Yoke	UJ647		H Yoke	UJ647
1978	F-150 w/ 3 Joint Shaft, 3.875" Yoke & Full Time Transfer Case: [Type 26]		1977-1976 F-150 w/ 2 Joint Shaft & Full Time Transfer Case: [Type 26]		
	U-Joint (Frnt. Shaft; Frnt.)ⓐ	UJ354		U-Joint (Frnt. Shaft; Frnt.)ⓐ	UJ369
	Brute Force Greaseable	UJ270		Brute Force Greaseable	UJ280
	Brute Force Non Greaseable	UJ254		Brute Force Non Greaseable	UJ269
	(For Aluminum Drive Shaft)	UJ354C		(For Aluminum Drive Shaft)	UJ369C
	U-Joint (Frnt. Shaft; Rr.)ⓑ	[2] UJ379		U-Joint (Frnt. Shaft; Rr.)ⓑ	[2] UJ379
	Brute Force Greaseable	UJ280		Brute Force Greaseable	UJ280
	Brute Force Non Greaseable	UJ269		Brute Force Non Greaseable	UJ269
	U-Joint (Rr. Shaft; Frnt.)ⓐ	[2] UJ354		U-Joint (Rr. Shaft; Frnt.)ⓐ	UJ369
	Brute Force Greaseable	UJ270		Brute Force Greaseable	UJ280
	Brute Force Non Greaseable	UJ254		Brute Force Non Greaseable	UJ269
	(For Aluminum Drive Shaft)	UJ354C		(For Aluminum Drive Shaft)	UJ369C
	U-Joint (Rr. Shaft; Rr.)ⓑ	UJ354		U-Joint (Rr. Shaft; Rr.)ⓑ	UJ369
	Brute Force Greaseable	UJ270		Brute Force Greaseable	UJ280
	Brute Force Non Greaseable	UJ254		Brute Force Non Greaseable	UJ269
	(For Aluminum Drive Shaft)	UJ354C		(For Aluminum Drive Shaft)	UJ369C
	U-Joint (Wheel Joint)ⓐ	[2] UJ371		U-Joint (Wheel Joint)ⓐ	[2] UJ371
	Brute Force Greaseable	UJ377		Brute Force Greaseable	UJ377
	Brute Force Non Greaseable	UJ371		Brute Force Non Greaseable	UJ371
	Centering Yoke	UJ607		Centering Yoke	UJ607
	H Yoke	UJ647		Weld Yoke	UJ633
				H Yoke	UJ647

(Continued)

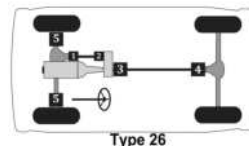

Passenger cars, light & medium trucks

Ford Truck 1/2 ton -- (Cont.)

MFG./YEAR	MODEL & LOCATION	PART NO.	MFG./YEAR	MODEL & LOCATION	PART NO.
Drive Shaft (4 W/D) (Cont.)			Drive Shaft (4 W/D) (Cont.)		
U-Joint (Cont.)			U-Joint (Cont.)		
1977-1976 F-150 w/ 2 Joint Shaft & Part Time Transfer Case: [Type 26]			1977-1976 F-150 w/ 3 Joint Shaft, 3.5" Yoke & Part Time Transfer Case Exc. CV Joint: [Type 27]		
U-Joint (Fr. Shaft; Frt.)⊙		UJ369	U-Joint (Fr. Shaft; Frt.)⊙		UJ369
Brute Force Greaseable		UJ280	Brute Force Greaseable		UJ280
Brute Force Non Greaseable		UJ269	Brute Force Non Greaseable		UJ269
(For Aluminum Drive Shaft)		UJ369C	(For Aluminum Drive Shaft)		UJ369C
U-Joint (Fr. Shaft; Rr.)⊙		UJ369	U-Joint (Fr. Shaft; Rr.)⊙		UJ369
Brute Force Greaseable		UJ280	Brute Force Greaseable		UJ280
Brute Force Non Greaseable		UJ269	Brute Force Non Greaseable		UJ269
(For Aluminum Drive Shaft)		UJ369C	(For Aluminum Drive Shaft)		UJ369C
U-Joint (Rr. Shaft; Frt.)⊙		UJ369	U-Joint (Rr. Shaft; Frt.)⊙		UJ369
Brute Force Greaseable		UJ280	Brute Force Greaseable		UJ280
Brute Force Non Greaseable		UJ269	Brute Force Non Greaseable		UJ269
(For Aluminum Drive Shaft)		UJ369C	(For Aluminum Drive Shaft)		UJ369C
U-Joint (Rr. Shaft; Rr.)⊙		UJ369	U-Joint (Rr. Shaft; Rr.)⊙		UJ369
Brute Force Greaseable		UJ280	Brute Force Greaseable		UJ280
Brute Force Non Greaseable		UJ269	Brute Force Non Greaseable		UJ269
(For Aluminum Drive Shaft)		UJ369C	(For Aluminum Drive Shaft)		UJ369C
U-Joint (Wheel Joint)⊙	[2]	UJ371	U-Joint (Rr. Shaft; Ctr.)⊙		UJ369
Brute Force Greaseable		UJ377	Brute Force Greaseable		UJ280
Brute Force Non Greaseable		UJ371	Brute Force Non Greaseable		UJ269
			(For Aluminum Drive Shaft)		UJ369C
1977-1976 F-150 w/ 3 Joint Shaft, 3.5" Yoke & Full Time Transfer Case Exc. CV Joint: [Type 27]			U-Joint (Rr. Shaft; Rr.)⊙		UJ369
U-Joint (Fr. Shaft; Frt.)⊙		UJ369	Brute Force Greaseable		UJ280
Brute Force Greaseable		UJ280	Brute Force Non Greaseable		UJ269
Brute Force Non Greaseable		UJ269	(For Aluminum Drive Shaft)		UJ369C
(For Aluminum Drive Shaft)		UJ369C	U-Joint (Wheel Joint)⊙	[2]	UJ371
U-Joint (Fr. Shaft; Rr.)⊙	[2]	UJ379	Brute Force Greaseable		UJ377
Brute Force Greaseable		UJ280	Brute Force Non Greaseable		UJ371
Brute Force Non Greaseable		UJ269			
(For Aluminum Drive Shaft)		UJ369C	Centering Yoke		UJ607
U-Joint (Rr. Shaft; Frt.)⊙		UJ369	Weld Yoke		UJ633
Brute Force Greaseable		UJ280	H Yoke		UJ647
Brute Force Non Greaseable		UJ269			
(For Aluminum Drive Shaft)		UJ369C			
U-Joint (Rr. Shaft; Ctr.)⊙		UJ369			
Brute Force Greaseable		UJ280			
Brute Force Non Greaseable		UJ269			
(For Aluminum Drive Shaft)		UJ369C			
U-Joint (Rr. Shaft; Rr.)⊙		UJ369			
Brute Force Greaseable		UJ280			
Brute Force Non Greaseable		UJ269			
(For Aluminum Drive Shaft)		UJ369C			
U-Joint (Wheel Joint)⊙	[2]	UJ371			
Brute Force Greaseable		UJ377			
Brute Force Non Greaseable		UJ371			

(Continued)

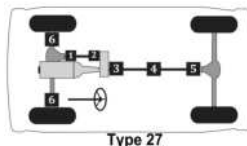
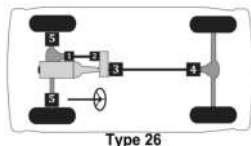

Passenger cars, light & medium trucks

(Cont.) -- Ford Truck 1/2 ton

MFG./YEAR	MODEL & LOCATION	PART NO.	MFG./YEAR	MODEL & LOCATION	PART NO.
Drive Shaft (4 W/D) (Cont.)			Drive Shaft (4 W/D) (Cont.)		
U-Joint (Cont.)			U-Joint (Cont.)		
1977-1976 F-150 w/ 3 Joint Shaft, 3.875" Yoke & Full Time Transfer Case Exc. CV			1977-1976 F-150 w/ 3 Joint Shaft, 3.875" Yoke & Part Time Transfer Case Exc. CV		
Joint: [Type 27]			Joint: [Type 27]		
U-Joint (Frnt. Shaft; Frnt.)①		UJ369	U-Joint (Frnt. Shaft; Frnt.)①		UJ369
Brute Force Greaseable		UJ280	Brute Force Greaseable		UJ280
Brute Force Non Greaseable		UJ269	Brute Force Non Greaseable		UJ269
(For Aluminum Drive Shaft)		UJ369C	(For Aluminum Drive Shaft)		UJ369C
U-Joint (Frnt. Shaft; Rr.)②	[2]	UJ379	U-Joint (Frnt. Shaft; Rr.)②		UJ369
Brute Force Greaseable		UJ280	Brute Force Greaseable		UJ280
Brute Force Non Greaseable		UJ269	Brute Force Non Greaseable		UJ269
(For Aluminum Drive Shaft)		UJ369C	(For Aluminum Drive Shaft)		UJ369C
U-Joint (Rr. Shaft; Frnt.)③		UJ369	U-Joint (Rr. Shaft; Frnt.)③		UJ369
Brute Force Greaseable		UJ280	Brute Force Greaseable		UJ280
Brute Force Non Greaseable		UJ269	Brute Force Non Greaseable		UJ269
(For Aluminum Drive Shaft)		UJ369C	(For Aluminum Drive Shaft)		UJ369C
U-Joint (Rr. Shaft; Ctr.)④		UJ369	U-Joint (Rr. Shaft; Ctr.)④		UJ369
Brute Force Greaseable		UJ280	Brute Force Greaseable		UJ280
Brute Force Non Greaseable		UJ269	Brute Force Non Greaseable		UJ269
(For Aluminum Drive Shaft)		UJ369C	(For Aluminum Drive Shaft)		UJ369C
U-Joint (Rr. Shaft; Rr.)⑤		UJ354	U-Joint (Rr. Shaft; Rr.)⑤		UJ354
Brute Force Greaseable		UJ270	Brute Force Greaseable		UJ270
Brute Force Non Greaseable		UJ254	Brute Force Non Greaseable		UJ254
(For Aluminum Drive Shaft)		UJ354C	(For Aluminum Drive Shaft)		UJ354C
U-Joint (Wheel Joint)⑥	[2]	UJ371	U-Joint (Wheel Joint)⑥	[2]	UJ371
Brute Force Greaseable		UJ377	Brute Force Greaseable		UJ377
Brute Force Non Greaseable		UJ371	Brute Force Non Greaseable		UJ377
Centering Yoke		UJ607	Centering Yoke		UJ607
Weld Yoke		UJ633	Weld Yoke		UJ633
H Yoke		UJ647	H Yoke		UJ647
					(Continued)
			1977-1976 F-150 w/ 3 Joint Shaft, 3.5" Yoke, CV		
			Joint & Full Time Transfer Case:		
			[Type 26]		
U-Joint (Frnt. Shaft; Frnt.)①		UJ369	U-Joint (Frnt. Shaft; Frnt.)①		UJ369
Brute Force Greaseable		UJ280	Brute Force Greaseable		UJ280
Brute Force Non Greaseable		UJ269	Brute Force Non Greaseable		UJ269
(For Aluminum Drive Shaft)		UJ369C	(For Aluminum Drive Shaft)		UJ369C
U-Joint (Frnt. Shaft; Rr.)②	[2]	UJ379	U-Joint (Frnt. Shaft; Rr.)②	[2]	UJ379
Brute Force Greaseable		UJ280	Brute Force Greaseable		UJ280
Brute Force Non Greaseable		UJ269	Brute Force Non Greaseable		UJ269
(For Aluminum Drive Shaft)		UJ369C	(For Aluminum Drive Shaft)		UJ369C
U-Joint (Rr. Shaft; Frnt.)③	[2]	UJ379	U-Joint (Rr. Shaft; Frnt.)③	[2]	UJ379
Brute Force Greaseable		UJ280	Brute Force Greaseable		UJ280
Brute Force Non Greaseable		UJ269	Brute Force Non Greaseable		UJ269
(For Aluminum Drive Shaft)		UJ369C	(For Aluminum Drive Shaft)		UJ369C
U-Joint (Rr. Shaft; Rr.)④		UJ369	U-Joint (Rr. Shaft; Rr.)④		UJ369
Brute Force Greaseable		UJ280	Brute Force Greaseable		UJ280
Brute Force Non Greaseable		UJ269	Brute Force Non Greaseable		UJ269
(For Aluminum Drive Shaft)		UJ369C	(For Aluminum Drive Shaft)		UJ369C
U-Joint (Wheel Joint)⑥	[2]	UJ371	U-Joint (Wheel Joint)⑥	[2]	UJ371
Brute Force Greaseable		UJ377	Brute Force Greaseable		UJ377
Brute Force Non Greaseable		UJ371	Brute Force Non Greaseable		UJ377
Centering Yoke		UJ607	Centering Yoke		UJ607
Weld Yoke		UJ633	Weld Yoke		UJ633
H Yoke		UJ647	H Yoke		UJ647

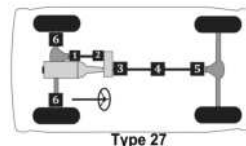
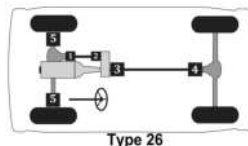

Passenger cars, light & medium trucks

Ford Truck 1/2 ton -- (Cont.)

MFG./YEAR	MODEL & LOCATION	PART NO.	MFG./YEAR	MODEL & LOCATION	PART NO.
Drive Shaft (4 W/D) (Cont.)			Drive Shaft (4 W/D) (Cont.)		
U-Joint (Cont.)			U-Joint (Cont.)		
1977-1976 F-150 w/ 3 Joint Shaft, 3.5" Yoke, CV			1977-1976 F-150 w/ 3 Joint Shaft, 3.875" Yoke,		
Joint & Part Time Transfer Case:			CV Joint & Part Time Transfer Case:		
[Type 26]			[Type 26]		
U-Joint (Fr. Shaft; Frt.) [⊙]		UJ369	U-Joint (Fr. Shaft; Frt.) [⊙]		UJ369
Brute Force Greaseable		UJ280	Brute Force Greaseable		UJ280
Brute Force Non Greaseable		UJ269	Brute Force Non Greaseable		UJ269
(For Aluminum Drive Shaft)		UJ369C	(For Aluminum Drive Shaft)		UJ369C
U-Joint (Fr. Shaft; Rr.) [⊙]		UJ369	U-Joint (Fr. Shaft; Rr.) [⊙]		UJ369
Brute Force Greaseable		UJ280	Brute Force Greaseable		UJ280
Brute Force Non Greaseable		UJ269	Brute Force Non Greaseable		UJ269
(For Aluminum Drive Shaft)		UJ369C	(For Aluminum Drive Shaft)		UJ369C
U-Joint (Rr. Shaft; Frt.) [⊙]	[2]	UJ379	U-Joint (Rr. Shaft; Frt.) [⊙]	[2]	UJ379
Brute Force Greaseable		UJ280	Brute Force Greaseable		UJ280
Brute Force Non Greaseable		UJ269	Brute Force Non Greaseable		UJ269
U-Joint (Rr. Shaft; Rr.) [⊙]		UJ369	U-Joint (Rr. Shaft; Rr.) [⊙]		UJ354
Brute Force Greaseable		UJ280	Brute Force Greaseable		UJ270
Brute Force Non Greaseable		UJ269	Brute Force Non Greaseable		UJ254
(For Aluminum Drive Shaft)		UJ369C	(For Aluminum Drive Shaft)		UJ354C
U-Joint (Wheel Joint) [⊙]	[2]	UJ371	U-Joint (Wheel Joint) [⊙]	[2]	UJ371
Brute Force Greaseable		UJ377	Brute Force Greaseable		UJ377
Brute Force Non Greaseable		UJ371	Brute Force Non Greaseable		UJ371
Centering Yoke		UJ607	Centering Yoke		UJ607
1977-1976 F-150 w/ 3 Joint Shaft, 3.875" Yoke,			1975-1974 F-100 & w/ 2 Joint Shaft & Full Time		
CV Joint & Full Time Transfer Case:			Transfer Case: [Type 26]		
[Type 26]			[Type 26]		
U-Joint (Fr. Shaft; Frt.) [⊙]		UJ369	U-Joint (Fr. Shaft; Frt.) [⊙]		UJ369
Brute Force Greaseable		UJ280	Brute Force Greaseable		UJ280
Brute Force Non Greaseable		UJ269	Brute Force Non Greaseable		UJ269
(For Aluminum Drive Shaft)		UJ369C	(For Aluminum Drive Shaft)		UJ369C
U-Joint (Fr. Shaft; Rr.) [⊙]	[2]	UJ379	U-Joint (Fr. Shaft; Rr.) [⊙]	[2]	UJ379
Brute Force Greaseable		UJ280	Brute Force Greaseable		UJ280
Brute Force Non Greaseable		UJ269	Brute Force Non Greaseable		UJ269
U-Joint (Rr. Shaft; Frt.) [⊙]	[2]	UJ379	U-Joint (Rr. Shaft; Frt.) [⊙]		UJ369
Brute Force Greaseable		UJ280	Brute Force Greaseable		UJ280
Brute Force Non Greaseable		UJ269	Brute Force Non Greaseable		UJ269
U-Joint (Rr. Shaft; Rr.) [⊙]		UJ354	U-Joint (Rr. Shaft; Rr.) [⊙]		UJ369C
Brute Force Greaseable		UJ270	Brute Force Greaseable		UJ369
Brute Force Non Greaseable		UJ254	Brute Force Non Greaseable		UJ280
(For Aluminum Drive Shaft)		UJ354C	(For Aluminum Drive Shaft)		UJ269
U-Joint (Wheel Joint) [⊙]	[2]	UJ371	U-Joint (Wheel Joint) [⊙]	[2]	UJ369C
Brute Force Greaseable		UJ377	Brute Force Greaseable		UJ371
Brute Force Non Greaseable		UJ371	Brute Force Non Greaseable		UJ377
Centering Yoke		UJ607	Centering Yoke		UJ371
Weld Yoke		UJ633	Centering Yoke		UJ607
H Yoke		UJ647	Weld Yoke		UJ633
			H Yoke		UJ647

(Continued)

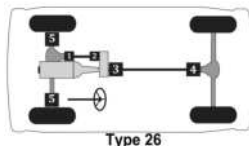

380 ▲ For Use w/ 1.063" Bearing Cap Application. ⊙ For Use w/ 1.188" Bearing Cap Application. ◇ For Use w/ Inner Lock Ring Application on Half Shaft. □ For Use w/ Outer Lock Ring Application on Half Shaft.



MFG./YEAR	MODEL & LOCATION	PART NO.	MFG./YEAR	MODEL & LOCATION	PART NO.
Drive Shaft (4 W/D) (Cont.)			Drive Shaft (4 W/D) (Cont.)		
U-Joint (Cont.)			U-Joint (Cont.)		
1975-1974 F-100 & w/ 2 Joint Shaft & Part Time			1975-1974 F-100 & w/ 3 Joint Shaft & Part Time		
Transfer Case: [Type 26]			Transfer Case: [Type 27]		
U-Joint (Frnt. Shaft; Frnt.) ^①		UJ369	U-Joint (Frnt. Shaft; Frnt.) ^①		UJ369
Brute Force Greaseable		UJ280	Brute Force Greaseable		UJ280
Brute Force Non Greaseable		UJ269	Brute Force Non Greaseable		UJ269
(For Aluminum Drive Shaft)		UJ369C	(For Aluminum Drive Shaft)		UJ369C
U-Joint (Frnt. Shaft; Rr.) ^②		UJ369	U-Joint (Frnt. Shaft; Rr.) ^②		UJ369
Brute Force Greaseable		UJ280	Brute Force Greaseable		UJ280
Brute Force Non Greaseable		UJ269	Brute Force Non Greaseable		UJ269
(For Aluminum Drive Shaft)		UJ369C	(For Aluminum Drive Shaft)		UJ369C
U-Joint (Rr. Shaft; Frnt.) ^③		UJ369	U-Joint (Rr. Shaft; Frnt.) ^③		UJ369
Brute Force Greaseable		UJ280	Brute Force Greaseable		UJ280
Brute Force Non Greaseable		UJ269	Brute Force Non Greaseable		UJ269
(For Aluminum Drive Shaft)		UJ369C	(For Aluminum Drive Shaft)		UJ369C
U-Joint (Rr. Shaft; Rr.) ^④	[2]	UJ369	U-Joint (Rr. Shaft; Rr.) ^④		UJ369
Brute Force Greaseable		UJ280	Brute Force Greaseable		UJ280
Brute Force Non Greaseable		UJ269	Brute Force Non Greaseable		UJ269
(For Aluminum Drive Shaft)		UJ369C	(For Aluminum Drive Shaft)		UJ369C
U-Joint (Wheel Joint) ^⑤	[2]	UJ371	U-Joint (Wheel Joint) ^⑤	[2]	UJ371
Brute Force Greaseable		UJ377	Brute Force Greaseable		UJ377
Brute Force Non Greaseable		UJ371	Brute Force Non Greaseable		UJ371
1975-1974 F-100 & w/ 3 Joint Shaft & Full Time			1973-1972 F-100 w/ 2 Joint Shaft: [Type 26]		
Transfer Case: [Type 27]			Transfer Case: [Type 26]		
U-Joint (Frnt. Shaft; Frnt.) ^①		UJ369	U-Joint (Frnt. Shaft; Frnt.) ^①		UJ369
Brute Force Greaseable		UJ280	Brute Force Greaseable		UJ280
Brute Force Non Greaseable		UJ269	Brute Force Non Greaseable		UJ269
(For Aluminum Drive Shaft)		UJ369C	(For Aluminum Drive Shaft)		UJ369C
U-Joint (Frnt. Shaft; Rr.) ^②	[2]	UJ379	U-Joint (Frnt. Shaft; Rr.) ^②		UJ369
Brute Force Greaseable		UJ280	Brute Force Greaseable		UJ280
Brute Force Non Greaseable		UJ269	Brute Force Non Greaseable		UJ269
(For Aluminum Drive Shaft)		UJ369C	(For Aluminum Drive Shaft)		UJ369C
U-Joint (Rr. Shaft; Frnt.) ^③		UJ369	U-Joint (Rr. Shaft; Frnt.) ^③		UJ369
Brute Force Greaseable		UJ280	Brute Force Greaseable		UJ280
Brute Force Non Greaseable		UJ269	Brute Force Non Greaseable		UJ269
(For Aluminum Drive Shaft)		UJ369C	(For Aluminum Drive Shaft)		UJ369C
U-Joint (Rr. Shaft; Rr.) ^④		UJ369	U-Joint (Rr. Shaft; Rr.) ^④		UJ369
Brute Force Greaseable		UJ280	Brute Force Greaseable		UJ280
Brute Force Non Greaseable		UJ269	Brute Force Non Greaseable		UJ269
(For Aluminum Drive Shaft)		UJ369C	(For Aluminum Drive Shaft)		UJ369C
U-Joint (Wheel Joint) ^⑤	[2]	UJ371	U-Joint (Wheel Joint) ^⑤	[2]	UJ371
Brute Force Greaseable		UJ377	Brute Force Greaseable		UJ377
Brute Force Non Greaseable		UJ371	Brute Force Non Greaseable		UJ371
Centering Yoke		UJ607			
Weld Yoke		UJ633			
H Yoke		UJ647			

(Continued)

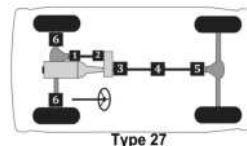
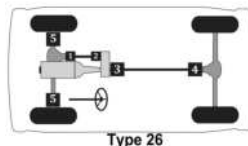

Passenger cars, light & medium trucks

Ford Truck 1/2 ton -- (Cont.)

MFG./YEAR	MODEL & LOCATION	PART NO.	MFG./YEAR	MODEL & LOCATION	PART NO.
Drive Shaft (4 W/D) (Cont.)			Drive Shaft (4 W/D) (Cont.)		
U-Joint (Cont.)			U-Joint (Cont.)		
1973-1972 F-100 w/ 3 Joint Shaft: [Type 27]			1971-1970 F-100 w/ 3 Joint Shaft: [Type 27]		
	U-Joint (Fr. Shaft; Frt.) [⊙]	UJ369		U-Joint (Fr. Shaft; Frt.) [⊙]	UJ369
	Brute Force Greaseable	UJ280		Brute Force Greaseable	UJ280
	Brute Force Non Greaseable	UJ269		Brute Force Non Greaseable	UJ269
	(For Aluminum Drive Shaft)	UJ369C		(For Aluminum Drive Shaft)	UJ369C
	U-Joint (Fr. Shaft; Rr.) [⊙]	UJ369		U-Joint (Fr. Shaft; Rr.) [⊙]	UJ369
	Brute Force Greaseable	UJ280		Brute Force Greaseable	UJ280
	Brute Force Non Greaseable	UJ269		Brute Force Non Greaseable	UJ269
	(For Aluminum Drive Shaft)	UJ369C		(For Aluminum Drive Shaft)	UJ369C
	U-Joint (Rr. Shaft; Frt.) [⊙]	UJ369		U-Joint (Rr. Shaft; Frt.) [⊙]	UJ369
	Brute Force Greaseable	UJ280		Brute Force Greaseable	UJ280
	Brute Force Non Greaseable	UJ269		Brute Force Non Greaseable	UJ269
	(For Aluminum Drive Shaft)	UJ369C		(For Aluminum Drive Shaft)	UJ369C
	U-Joint (Rr. Shaft; Ctr.) [⊙]	UJ369		U-Joint (Rr. Shaft; Ctr.) [⊙]	UJ369
	Brute Force Greaseable	UJ280		Brute Force Greaseable	UJ280
	Brute Force Non Greaseable	UJ269		Brute Force Non Greaseable	UJ269
	(For Aluminum Drive Shaft)	UJ369C		(For Aluminum Drive Shaft)	UJ369C
	U-Joint (Rr. Shaft; Rr.) [⊙]	UJ369		U-Joint (Rr. Shaft; Rr.) [⊙]	UJ369
	Brute Force Greaseable	UJ280		Brute Force Greaseable	UJ280
	Brute Force Non Greaseable	UJ269		Brute Force Non Greaseable	UJ269
	(For Aluminum Drive Shaft)	UJ369C		(For Aluminum Drive Shaft)	UJ369C
	U-Joint (Wheel Joint) [⊙]	[2] UJ371		U-Joint (Wheel Joint) [⊙]	[2] UJ365
	Brute Force Greaseable	UJ377		Brute Force Greaseable	UJ378
	Brute Force Non Greaseable	UJ371		Brute Force Non Greaseable	UJ365
	1971-1970 F-100 w/ 2 Joint Shaft: [Type 26]			1969-1967 F-100 w/ 2 Joint Shaft & 3.5" Yoke:	
	U-Joint (Fr. Shaft; Frt.) [⊙]	UJ369		[Type 26]	
	Brute Force Greaseable	UJ280		U-Joint (Fr. Shaft; Frt.) [⊙]	UJ369
	Brute Force Non Greaseable	UJ269		Brute Force Greaseable	UJ280
	(For Aluminum Drive Shaft)	UJ369C		Brute Force Non Greaseable	UJ269
	U-Joint (Fr. Shaft; Rr.) [⊙]	UJ369		(For Aluminum Drive Shaft)	UJ369C
	Brute Force Greaseable	UJ280		U-Joint (Fr. Shaft; Rr.) [⊙]	UJ369
	Brute Force Non Greaseable	UJ269		Brute Force Greaseable	UJ280
	(For Aluminum Drive Shaft)	UJ369C		Brute Force Non Greaseable	UJ269
	U-Joint (Rr. Shaft; Frt.) [⊙]	UJ369		(For Aluminum Drive Shaft)	UJ369C
	Brute Force Greaseable	UJ280		U-Joint (Rr. Shaft; Frt.) [⊙]	UJ369
	Brute Force Non Greaseable	UJ269		Brute Force Greaseable	UJ280
	(For Aluminum Drive Shaft)	UJ369C		Brute Force Non Greaseable	UJ269
	U-Joint (Rr. Shaft; Rr.) [⊙]	UJ369		(For Aluminum Drive Shaft)	UJ369C
	Brute Force Greaseable	UJ280		U-Joint (Rr. Shaft; Rr.) [⊙]	UJ369
	Brute Force Non Greaseable	UJ269		Brute Force Greaseable	UJ280
	(For Aluminum Drive Shaft)	UJ369C		Brute Force Non Greaseable	UJ269
	U-Joint (Wheel Joint) [⊙]	[2] UJ365		(For Aluminum Drive Shaft)	UJ369C
	Brute Force Greaseable	UJ378		U-Joint (Wheel Joint) [⊙]	[2] UJ365
	Brute Force Non Greaseable	UJ365		Brute Force Greaseable	UJ378
				Brute Force Non Greaseable	UJ365

(Continued)

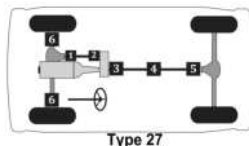
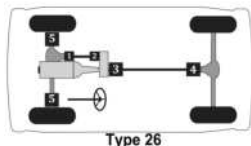

MFG./YEAR	MODEL & LOCATION	PART NO.	MFG./YEAR	MODEL & LOCATION	PART NO.
Drive Shaft (4 W/D) (Cont.)			Drive Shaft (4 W/D) (Cont.)		
U-Joint (Cont.)			U-Joint (Cont.)		
1969-1967 F-100 w/ 2 Joint Shaft & 3.875" Yoke:			1969-1967 F-100 w/ 3 Joint Shaft & 3.875" Yoke:		
[Type 26]			[Type 27]		
U-Joint (Frnt. Shaft; Frnt.) ^①		UJ353	U-Joint (Frnt. Shaft; Frnt.) ^①		UJ353
Brute Force Greaseable		UJ275	Brute Force Greaseable		UJ275
U-Joint (Frnt. Shaft; Rr.) ^②		UJ353	U-Joint (Frnt. Shaft; Rr.) ^②		UJ353
Brute Force Greaseable		UJ275	Brute Force Greaseable		UJ275
U-Joint (Rr. Shaft; Frnt.) ^③		UJ353	U-Joint (Rr. Shaft; Frnt.) ^③		UJ353
Brute Force Greaseable		UJ275	Brute Force Greaseable		UJ275
U-Joint (Rr. Shaft; Rr.) ^④		UJ353	U-Joint (Rr. Shaft; Ctr.) ^④		UJ369
Brute Force Greaseable		UJ275	Brute Force Greaseable		UJ280
U-Joint (Wheel Joint) ^⑤	[2]	UJ365	Brute Force Non Greaseable		UJ269
Brute Force Greaseable		UJ378	(For Aluminum Drive Shaft)		UJ369C
Brute Force Non Greaseable		UJ365	U-Joint (Rr. Shaft; Rr.) ^⑤		UJ353
1969-1967 F-100 w/ 3 Joint Shaft & 3.5" Yoke:			Brute Force Greaseable		UJ275
[Type 27]			U-Joint (Wheel Joint) ^⑥	[2]	UJ365
U-Joint (Frnt. Shaft; Frnt.) ^①		UJ369	Brute Force Greaseable		UJ378
Brute Force Greaseable		UJ280	Brute Force Non Greaseable		UJ365
Brute Force Non Greaseable		UJ269	1966 F-100 w/ 2 Joint Shaft: [Type 26]		
(For Aluminum Drive Shaft)		UJ369C	U-Joint (Frnt. Shaft; Frnt.) ^①		UJ353
U-Joint (Frnt. Shaft; Rr.) ^②		UJ369	Brute Force Greaseable		UJ275
Brute Force Greaseable		UJ280	U-Joint (Frnt. Shaft; Rr.) ^②		UJ353
Brute Force Non Greaseable		UJ269	Brute Force Greaseable		UJ275
(For Aluminum Drive Shaft)		UJ369C	U-Joint (Rr. Shaft; Frnt.) ^③		UJ353
U-Joint (Rr. Shaft; Frnt.) ^③		UJ369	Brute Force Greaseable		UJ275
Brute Force Greaseable		UJ280	U-Joint (Rr. Shaft; Rr.) ^④		UJ353
Brute Force Non Greaseable		UJ269	Brute Force Greaseable		UJ275
(For Aluminum Drive Shaft)		UJ369C	U-Joint (Wheel Joint) ^⑤	[2]	UJ365
U-Joint (Rr. Shaft; Ctr.) ^④		UJ369	Brute Force Greaseable		UJ378
Brute Force Greaseable		UJ280	Brute Force Non Greaseable		UJ365
Brute Force Non Greaseable		UJ269	1966 F-100 w/ 3 Joint Shaft: [Type 27]		
(For Aluminum Drive Shaft)		UJ369C	U-Joint (Frnt. Shaft; Frnt.) ^①		UJ353
U-Joint (Rr. Shaft; Rr.) ^⑤		UJ369	Brute Force Greaseable		UJ275
Brute Force Greaseable		UJ280	U-Joint (Frnt. Shaft; Rr.) ^②		UJ353
Brute Force Non Greaseable		UJ269	Brute Force Greaseable		UJ275
(For Aluminum Drive Shaft)		UJ369C	U-Joint (Rr. Shaft; Frnt.) ^③		UJ353
U-Joint (Wheel Joint) ^⑥	[2]	UJ365	Brute Force Greaseable		UJ275
Brute Force Greaseable		UJ378	U-Joint (Rr. Shaft; Ctr.) ^④		UJ369
Brute Force Non Greaseable		UJ365	Brute Force Greaseable		UJ280
			Brute Force Non Greaseable		UJ269
			(For Aluminum Drive Shaft)		UJ369C
			U-Joint (Rr. Shaft; Rr.) ^⑤		UJ353
			Brute Force Greaseable		UJ275
			U-Joint (Wheel Joint) ^⑥	[2]	UJ365
			Brute Force Greaseable		UJ378
			Brute Force Non Greaseable		UJ365

(Continued)

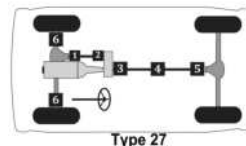
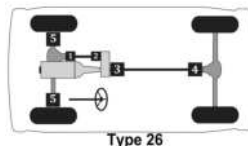

Passenger cars, light & medium trucks

Ford Truck 1/2 ton -- (Cont.)

MFG./YEAR	MODEL & LOCATION	PART NO.	MFG./YEAR	MODEL & LOCATION	PART NO.
Drive Shaft (4 W/D) (Cont.)			Drive Shaft (4 W/D) (Cont.)		
U-Joint (Cont.)			U-Joint (Cont.)		
			1965-1959 F-100: [Type 34]		
			U-Joint (Frnt. Shaft; Frt.)Ⓚ UJ353		
			<i>Brute Force Greaseable</i> UJ275		
			U-Joint (Frnt. Shaft; Rr.)Ⓚ UJ353		
			<i>Brute Force Greaseable</i> UJ275		
			U-Joint (Intmd. Shaft; Frt.)Ⓚ UJ369		
			<i>Brute Force Greaseable</i> UJ280		
			<i>Brute Force Non Greaseable</i> UJ269		
			(For Aluminum Drive Shaft) UJ369C		
			U-Joint (Intmd. Shaft; Rr.)Ⓚ UJ369		
			<i>Brute Force Greaseable</i> UJ280		
			<i>Brute Force Non Greaseable</i> UJ269		
			(For Aluminum Drive Shaft) UJ369C		
			U-Joint (Rr. Shaft; Frt.)Ⓚ UJ353		
			<i>Brute Force Greaseable</i> UJ275		
			U-Joint (Rr. Shaft; Rr.)Ⓚ UJ353		
			<i>Brute Force Greaseable</i> UJ275		
			U-Joint (Wheel Joint)Ⓚ [2] UJ365		
			<i>Brute Force Greaseable</i> UJ378		
			<i>Brute Force Non Greaseable</i> UJ365		

Ford Truck 3/4 ton

<p>Drive Shaft (2 W/D)</p> <p>U-Joint</p> <p>2020-2018 F-250 Super Duty w/ 2 Joint Shaft & Bearing 1.375" Dia. Brg. Cap: [Type 1]</p> <p>U-Joint (Front)Ⓚ UJ351A</p> <p><i>Brute Force Non Greaseable</i> UJ351ABF</p> <p>U-Joint (Rear)Ⓚ UJ351A</p> <p><i>Brute Force Non Greaseable</i> UJ351ABF</p> <p>2020-2018 F-250 Super Duty w/ 2 Joint Shaft & Bearing 1.188" Dia. Brg. Cap: [Type 1]</p> <p>U-Joint (Front)Ⓚ UJ330</p> <p><i>Brute Force Greaseable</i> UJ295</p> <p>(For Aluminum Drive Shaft) UJ330C</p> <p>U-Joint (Rear)Ⓚ UJ330</p> <p><i>Brute Force Greaseable</i> UJ295</p> <p>(For Aluminum Drive Shaft) UJ330C</p>	<p>Drive Shaft (2 W/D) (Cont.)</p> <p>U-Joint (Cont.)</p> <p>2020-2018 F-250 Super Duty w/ 3 Joint Shaft & Bearing 1.188" Dia. Brg. Cap: [Type 2]</p> <p>U-Joint (Front)Ⓚ UJ330</p> <p><i>Brute Force Greaseable</i> UJ295</p> <p>(For Aluminum Drive Shaft) UJ330C</p> <p>U-Joint (Center)Ⓚ UJ330</p> <p><i>Brute Force Greaseable</i> UJ295</p> <p>(For Aluminum Drive Shaft) UJ330C</p> <p>U-Joint (Rear)Ⓚ UJ330</p> <p><i>Brute Force Greaseable</i> UJ295</p> <p>(For Aluminum Drive Shaft) UJ330C</p> <p>2019-2018 F-250 Super Duty w/ 3 Joint Shaft & Bearing 1.375" Dia. Brg. Cap: [Type 2]</p> <p>U-Joint (Front)Ⓚ UJ351A</p> <p><i>Brute Force Non Greaseable</i> UJ351ABF</p> <p>U-Joint (Center)Ⓚ UJ351A</p> <p><i>Brute Force Non Greaseable</i> UJ351ABF</p> <p>U-Joint (Rear)Ⓚ UJ351A</p> <p><i>Brute Force Non Greaseable</i> UJ351ABF</p> <p style="text-align: right;">(Continued)</p>
---	--

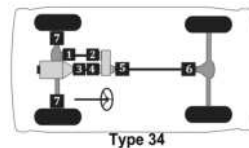
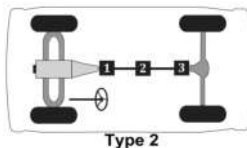
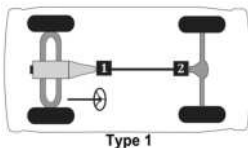

MFG./YEAR	MODEL & LOCATION	PART NO.	MFG./YEAR	MODEL & LOCATION	PART NO.
Drive Shaft (2 W/D) (Cont.)			Drive Shaft (2 W/D) (Cont.)		
U-Joint (Cont.)			U-Joint (Cont.)		
2017-2005 F-250 Super Duty w/ 2 Joint Shaft:			2004-1998 F-250 & F-250 Super Duty w/ 2 Joint Shaft Exc. 10 Cyl. & Diesel Eng.:		
[Type 1]			[Type 1]		
	U-Joint (Front)Ⓢ	UJ330		U-Joint (Front)Ⓢ	UJ331
	<i>Brute Force Greaseable</i>	UJ295		<i>Brute Force Greaseable</i>	UJ232
	(For Aluminum Drive Shaft)	UJ330C		<i>Brute Force Non Greaseable</i>	UJ231
	Clamp Kit (Front)	UJ331-10		(For Aluminum Drive Shaft)	UJ331C
	U-Joint (Rear)Ⓢ	UJ330		Clamp Kit (Front)	UJ331-10
	<i>Brute Force Greaseable</i>	UJ295		U-Joint (Rear)Ⓢ	UJ331
	(For Aluminum Drive Shaft)	UJ330C		<i>Brute Force Greaseable</i>	UJ232
	Clamp Kit (Rear)	UJ331-10		<i>Brute Force Non Greaseable</i>	UJ231
2017-2005 F-250 Super Duty w/ 3 Joint Shaft:			2004-1998 F-250 & F-250 Super Duty w/ 3 Joint Shaft Exc. 10 Cyl. & Diesel Eng.:		
[Type 2]			[Type 2]		
	U-Joint (Front)Ⓢ	UJ330		U-Joint (Front)Ⓢ	UJ331
	<i>Brute Force Greaseable</i>	UJ295		<i>Brute Force Greaseable</i>	UJ232
	(For Aluminum Drive Shaft)	UJ330C		<i>Brute Force Non Greaseable</i>	UJ231
	Clamp Kit (Front)	UJ331-10		(For Aluminum Drive Shaft)	UJ331C
	U-Joint (Center)Ⓢ	UJ330		Clamp Kit (Front)	UJ331-10
	<i>Brute Force Greaseable</i>	UJ295		U-Joint (Center)Ⓢ	UJ331
	(For Aluminum Drive Shaft)	UJ330C		<i>Brute Force Greaseable</i>	UJ232
	Clamp Kit (Center)	UJ331-10		<i>Brute Force Non Greaseable</i>	UJ231
	U-Joint (Rear)Ⓢ	UJ330		(For Aluminum Drive Shaft)	UJ331C
	<i>Brute Force Greaseable</i>	UJ295		Clamp Kit (Center)	UJ331-10
	(For Aluminum Drive Shaft)	UJ330C		U-Joint (Rear)Ⓢ	UJ331
	Clamp Kit (Rear)	UJ331-10		<i>Brute Force Greaseable</i>	UJ232
2004-1999 F-250 Super Duty w/ 2 Joint Shaft, 10 Cyl. & Diesel Eng.: [Type 1]			1997 F-250 w/ 2 Joint Shaft Exc. 5.8L Eng.: [Type 1]		
	U-Joint (Front)Ⓢ	UJ330		U-Joint (Front)Ⓢ	UJ331
	<i>Brute Force Greaseable</i>	UJ295		<i>Brute Force Greaseable</i>	UJ232
	(For Aluminum Drive Shaft)	UJ330C		<i>Brute Force Non Greaseable</i>	UJ231
	Clamp Kit (Front)	UJ331-10		(For Aluminum Drive Shaft)	UJ331C
	U-Joint (Rear)Ⓢ	UJ330		Clamp Kit (Front)	UJ331-10
	<i>Brute Force Greaseable</i>	UJ295		U-Joint (Rear)Ⓢ	UJ331
	(For Aluminum Drive Shaft)	UJ330C		<i>Brute Force Greaseable</i>	UJ232
	Clamp Kit (Rear)	UJ331-10		<i>Brute Force Non Greaseable</i>	UJ231
2004-1999 F-250 Super Duty w/ 3 Joint Shaft, 10 Cyl. & Diesel Eng.: [Type 2]			2004-1998 F-250 & F-250 Super Duty w/ 3 Joint Shaft Exc. 10 Cyl. & Diesel Eng.: [Type 2]		
	U-Joint (Front)Ⓢ	UJ330		U-Joint (Front)Ⓢ	UJ331
	<i>Brute Force Greaseable</i>	UJ295		<i>Brute Force Greaseable</i>	UJ232
	(For Aluminum Drive Shaft)	UJ330C		<i>Brute Force Non Greaseable</i>	UJ231
	Clamp Kit (Front)	UJ331-10		(For Aluminum Drive Shaft)	UJ331C
	U-Joint (Center)Ⓢ	UJ330		Clamp Kit (Front)	UJ331-10
	<i>Brute Force Greaseable</i>	UJ295		U-Joint (Rear)Ⓢ	UJ331
	(For Aluminum Drive Shaft)	UJ330C		<i>Brute Force Greaseable</i>	UJ232
	Clamp Kit (Center)	UJ331-10		<i>Brute Force Non Greaseable</i>	UJ231
	U-Joint (Rear)Ⓢ	UJ330		(For Aluminum Drive Shaft)	UJ331C
	<i>Brute Force Greaseable</i>	UJ295		Clamp Kit (Rear)	UJ331-10
	(For Aluminum Drive Shaft)	UJ330C			(Continued)
	Clamp Kit (Rear)	UJ331-10			

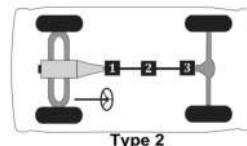
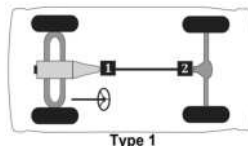

Passenger cars, light & medium trucks

Ford Truck 3/4 ton -- (Cont.)

MFG./YEAR	MODEL & LOCATION	PART NO.	MFG./YEAR	MODEL & LOCATION	PART NO.
Drive Shaft (2 W/D) (Cont.)			Drive Shaft (2 W/D) (Cont.)		
U-Joint (Cont.)			U-Joint (Cont.)		
1997	F-250 w/ 3 Joint Shaft Exc. 5.8L Eng.:		1997	F-250 w/ Ext. Cab, Short Bed & 5.8L Eng.:	
	[Type 2]			[Type 2]	
	U-Joint (Front)Ⓛ	UJ331		U-Joint (Front)Ⓛ	UJ331
	Brute Force Greaseable	UJ232		Brute Force Greaseable	UJ232
	Brute Force Non Greaseable	UJ231		Brute Force Non Greaseable	UJ231
	(For Aluminum Drive Shaft)	UJ331C		(For Aluminum Drive Shaft)	UJ331C
	Clamp Kit (Front)	UJ331-10		Clamp Kit (Front)	UJ331-10
	U-Joint (Center)Ⓛ	UJ331		U-Joint (Center)Ⓛ	UJ331
	Brute Force Greaseable	UJ232		Brute Force Greaseable	UJ232
	Brute Force Non Greaseable	UJ231		Brute Force Non Greaseable	UJ231
	(For Aluminum Drive Shaft)	UJ331C		(For Aluminum Drive Shaft)	UJ331C
	Clamp Kit (Center)	UJ331-10		Clamp Kit (Center)	UJ331-10
	U-Joint (Rear)Ⓛ	UJ331		U-Joint (Rear)Ⓛ	UJ331
	Brute Force Greaseable	UJ232		Brute Force Greaseable	UJ232
	Brute Force Non Greaseable	UJ231		Brute Force Non Greaseable	UJ231
	(For Aluminum Drive Shaft)	UJ331C		(For Aluminum Drive Shaft)	UJ331C
	Clamp Kit (Rear)	UJ331-10		Clamp Kit (Rear)	UJ331-10
1997	F-250 w/ Reg. Cab, Auto. Trans. & 5.8L Eng.:		1997	F-250 w/ Ext. Cab, Long Bed, Auto. Trans. & 5.8L Eng.:	
	[Type 1]			[Type 2]	
	U-Joint (Front)Ⓛ	UJ354		U-Joint (Front)Ⓛ	UJ354
	Brute Force Greaseable	UJ270		Brute Force Greaseable	UJ270
	Brute Force Non Greaseable	UJ254		Brute Force Non Greaseable	UJ254
	(For Aluminum Drive Shaft)	UJ354C		(For Aluminum Drive Shaft)	UJ354C
	U-Joint (Rear)Ⓛ	UJ434		U-Joint (Center)Ⓛ	UJ354
	Brute Force Greaseable	UJ265		Brute Force Greaseable	UJ270
	Brute Force Non Greaseable	UJ264		Brute Force Non Greaseable	UJ254
	U-Bolt Kit (Rear)	UJ534-10		(For Aluminum Drive Shaft)	UJ354C
1997	F-250 w/ Reg. Cab, Man. Trans. & 5.8L Eng.:		1997	F-250 w/ Ext. Cab, Long Bed, Man. Trans. & 5.8L Eng.:	
	[Type 2]			[Type 2]	
	U-Joint (Front)Ⓛ	UJ434		U-Joint (Front)Ⓛ	UJ434
	Brute Force Greaseable	UJ265		Brute Force Greaseable	UJ265
	Brute Force Non Greaseable	UJ264		Brute Force Non Greaseable	UJ264
	U-Bolt Kit (Front)	UJ534-10		U-Bolt Kit (Front)	UJ534-10
	U-Joint (Center)Ⓛ	UJ354		U-Joint (Center)Ⓛ	UJ354
	Brute Force Greaseable	UJ270		Brute Force Greaseable	UJ270
	Brute Force Non Greaseable	UJ254		Brute Force Non Greaseable	UJ254
	(For Aluminum Drive Shaft)	UJ354C		(For Aluminum Drive Shaft)	UJ354C
	U-Joint (Rear)Ⓛ	UJ434		U-Joint (Rear)Ⓛ	UJ434
	Brute Force Greaseable	UJ265		Brute Force Greaseable	UJ265
	Brute Force Non Greaseable	UJ264		Brute Force Non Greaseable	UJ264
	U-Bolt Kit (Rear)	UJ534-10		U-Bolt Kit (Rear)	UJ534-10

(Continued)

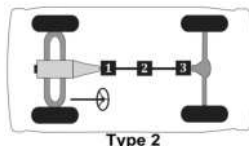
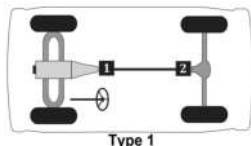

MFG./YEAR	MODEL & LOCATION	PART NO.	MFG./YEAR	MODEL & LOCATION	PART NO.
Drive Shaft (2 W/D) (Cont.)			Drive Shaft (2 W/D) (Cont.)		
U-Joint (Cont.)			U-Joint (Cont.)		
1997	F-250 w/ Crew Cab & 5.8L Eng.:		1996-1993	F-250 w/ 2 Joint Shaft & 4.9L & 5.8L	
	[Type 2]			Engs. [Type 1]	
	U-Joint (Front)Ⓢ	UJ331		U-Joint (Front)Ⓢ	UJ354
	Brute Force Greaseable	UJ232		Brute Force Greaseable	UJ270
	Brute Force Non Greaseable	UJ231		Brute Force Non Greaseable	UJ254
	(For Aluminum Drive Shaft)	UJ331C		(For Aluminum Drive Shaft)	UJ354C
	Clamp Kit (Front)	UJ331-10		U-Joint (Rear)Ⓢ	UJ434
	U-Joint (Center)Ⓢ	UJ331		Brute Force Greaseable	UJ265
	Brute Force Greaseable	UJ232		Brute Force Non Greaseable	UJ264
	Brute Force Non Greaseable	UJ231		U-Bolt Kit (Rear)	UJ534-10
	(For Aluminum Drive Shaft)	UJ331C		1996-1993 F-250 w/ 3 Joint Shaft & 4.9L & 5.8L	
	Clamp Kit (Center)	UJ331-10		Engs. [Type 2]	
	U-Joint (Rear)Ⓢ	UJ331		U-Joint (Front)Ⓢ	UJ354
	Brute Force Greaseable	UJ232		Brute Force Greaseable	UJ270
	Brute Force Non Greaseable	UJ231		Brute Force Non Greaseable	UJ254
	(For Aluminum Drive Shaft)	UJ331C		(For Aluminum Drive Shaft)	UJ354C
	Clamp Kit (Rear)	UJ331-10		U-Joint (Center)Ⓢ	UJ354
	1996-1995 F-250 w/ 2 Joint Shaft & 7.3L & 7.5L			Brute Force Greaseable	UJ270
	Engs. [Type 1]			Brute Force Non Greaseable	UJ254
	U-Joint (Front)Ⓢ	UJ331		(For Aluminum Drive Shaft)	UJ354C
	Brute Force Greaseable	UJ232		U-Joint (Rear)Ⓢ	UJ434
	Brute Force Non Greaseable	UJ231		Brute Force Greaseable	UJ265
	(For Aluminum Drive Shaft)	UJ331C		Brute Force Non Greaseable	UJ264
	Clamp Kit (Front)	UJ331-10		U-Bolt Kit (Rear)	UJ534-10
	U-Joint (Rear)Ⓢ	UJ331		1994-1993 F-250 w/ 2 Joint Shaft & 7.3L & 7.5L	
	Brute Force Greaseable	UJ232		Engs. [Type 1]	
	Brute Force Non Greaseable	UJ231		U-Joint (Front)Ⓢ	UJ354
	(For Aluminum Drive Shaft)	UJ331C		Brute Force Greaseable	UJ270
	Clamp Kit (Rear)	UJ331-10		Brute Force Non Greaseable	UJ254
	1996-1995 F-250 w/ 3 Joint Shaft & 7.3L & 7.5L			(For Aluminum Drive Shaft)	UJ354C
	Engs. [Type 2]			U-Joint (Rear)Ⓢ	UJ434
	U-Joint (Front)Ⓢ	UJ331		Brute Force Greaseable	UJ265
	Brute Force Greaseable	UJ232		Brute Force Non Greaseable	UJ264
	Brute Force Non Greaseable	UJ231		U-Bolt Kit (Rear)	UJ534-10
	(For Aluminum Drive Shaft)	UJ331C		1994-1993 F-250 w/ 3 Joint Shaft, Auto. Trans.,	
	Clamp Kit (Front)	UJ331-10		7.3L & 7.5L Engs. [Type 2]	
	U-Joint (Center)Ⓢ	UJ331		U-Joint (Front)Ⓢ	UJ354
	Brute Force Greaseable	UJ232		Brute Force Greaseable	UJ270
	Brute Force Non Greaseable	UJ231		Brute Force Non Greaseable	UJ254
	(For Aluminum Drive Shaft)	UJ331C		(For Aluminum Drive Shaft)	UJ354C
	Clamp Kit (Center)	UJ331-10		U-Joint (Center)Ⓢ	UJ354
	U-Joint (Rear)Ⓢ	UJ331		Brute Force Greaseable	UJ270
	Brute Force Greaseable	UJ232		Brute Force Non Greaseable	UJ254
	Brute Force Non Greaseable	UJ231		(For Aluminum Drive Shaft)	UJ354C
	(For Aluminum Drive Shaft)	UJ331C		U-Joint (Rear)Ⓢ	UJ434
	Clamp Kit (Rear)	UJ331-10		Brute Force Greaseable	UJ265
				Brute Force Non Greaseable	UJ264
				U-Bolt Kit (Rear)	UJ534-10

(Continued)

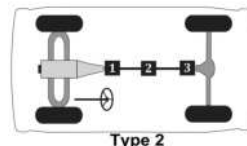
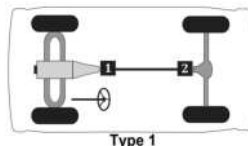

Passenger cars, light & medium trucks

Ford Truck 3/4 ton -- (Cont.)

MFG./YEAR	MODEL & LOCATION	PART NO.	MFG./YEAR	MODEL & LOCATION	PART NO.
Drive Shaft (2 W/D) (Cont.)			Drive Shaft (2 W/D) (Cont.)		
U-Joint (Cont.)			U-Joint (Cont.)		
1994-1993 F-250 w/ 3 Joint Shaft, Man. Trans., 7.3L & 7.5L Eng. [Type 2]			1992 F-250 w/ 3 Joint Shaft, Reg. Cab, 5.8L Eng. & HD 5 Spd. Man. Trans.: [Type 2]		
U-Joint (Front)Ⓛ		UJ331	U-Joint (Front)Ⓛ		UJ434
Brute Force Greaseable		UJ232	Brute Force Greaseable		UJ265
Brute Force Non Greaseable		UJ231	Brute Force Non Greaseable		UJ264
(For Aluminum Drive Shaft)		UJ331C	U-Bolt Kit (Front)		UJ534-10
Clamp Kit (Front)		UJ331-10	U-Joint (Center)Ⓞ		UJ354
U-Joint (Center)Ⓞ		UJ331	Brute Force Greaseable		UJ270
Brute Force Greaseable		UJ232	Brute Force Non Greaseable		UJ254
Brute Force Non Greaseable		UJ231	(For Aluminum Drive Shaft)		UJ354C
(For Aluminum Drive Shaft)		UJ331C	U-Joint (Rear)Ⓞ		UJ434
Clamp Kit (Center)		UJ331-10	Brute Force Greaseable		UJ265
U-Joint (Rear)Ⓞ		UJ331	Brute Force Non Greaseable		UJ264
Brute Force Greaseable		UJ232	U-Bolt Kit (Rear)		UJ534-10
Brute Force Non Greaseable		UJ231	1992 F-250 w/ 3 Joint Shaft, Reg. Cab, 7.3L, 7.5L Eng. & Man. Trans.: [Type 2]		
(For Aluminum Drive Shaft)		UJ331C	U-Joint (Front)Ⓛ		UJ331
Clamp Kit (Rear)		UJ331-10	Brute Force Greaseable		UJ232
1992 F-250 w/ 2 Joint Shaft & Standard Cab: [Type 1]			Brute Force Non Greaseable		UJ231
U-Joint (Front)Ⓛ		UJ354	(For Aluminum Drive Shaft)		UJ331C
Brute Force Greaseable		UJ270	Clamp Kit (Front)		UJ331-10
Brute Force Non Greaseable		UJ254	U-Joint (Center)Ⓞ		UJ331
(For Aluminum Drive Shaft)		UJ354C	Brute Force Greaseable		UJ232
U-Joint (Rear)Ⓞ		UJ434	Brute Force Non Greaseable		UJ231
Brute Force Greaseable		UJ265	(For Aluminum Drive Shaft)		UJ331C
Brute Force Non Greaseable		UJ264	Clamp Kit (Center)		UJ331-10
U-Bolt Kit (Rear)		UJ534-10	U-Joint (Rear)Ⓞ		UJ331
1992 F-250 w/ 3 Joint Shaft, Reg. Cab, 5.0L Eng. & 5 Spd. Man. Trans.: [Type 2]			Brute Force Greaseable		UJ232
U-Joint (Front)Ⓛ		UJ354	Brute Force Non Greaseable		UJ231
Brute Force Greaseable		UJ270	(For Aluminum Drive Shaft)		UJ331C
Brute Force Non Greaseable		UJ254	Clamp Kit (Rear)		UJ331-10
(For Aluminum Drive Shaft)		UJ354C	1992-1991 F-250 w/ 2 Joint Shaft & Ext. Cab: [Type 1]		
U-Joint (Center)Ⓞ		UJ354	U-Joint (Front)Ⓛ		UJ434
Brute Force Greaseable		UJ270	Brute Force Greaseable		UJ265
Brute Force Non Greaseable		UJ254	Brute Force Non Greaseable		UJ264
(For Aluminum Drive Shaft)		UJ354C	U-Bolt Kit (Front)		UJ534-10
U-Joint (Rear)Ⓞ		UJ434	U-Joint (Rear)Ⓞ		UJ434
Brute Force Greaseable		UJ265	Brute Force Greaseable		UJ265
Brute Force Non Greaseable		UJ264	Brute Force Non Greaseable		UJ264
U-Bolt Kit (Rear)		UJ534-10	U-Bolt Kit (Rear)		UJ534-10

(Continued)

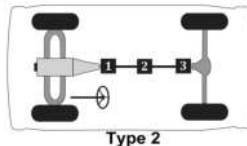
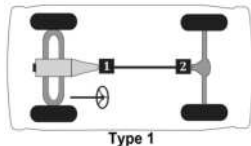

MFG./YEAR	MODEL & LOCATION	PART NO.	MFG./YEAR	MODEL & LOCATION	PART NO.
Drive Shaft (2 W/D) (Cont.)			Drive Shaft (2 W/D) (Cont.)		
U-Joint (Cont.)			U-Joint (Cont.)		
1992-1990 F-250 w/ 3 Joint Shaft, Reg. Cab, 4.9L Eng. & HD 5 Spd. Man. Trans.: [Type 2]			1992-1990 F-250 w/ 3 Joint Shaft, Ext. Cab, 7.3L & 7.5L Eng. [Type 2]		
	U-Joint (Front)Ⓢ	UJ434		U-Joint (Front)Ⓢ	UJ331
	<i>Brute Force Greaseable</i>	UJ265		<i>Brute Force Greaseable</i>	UJ232
	<i>Brute Force Non Greaseable</i>	UJ264		<i>Brute Force Non Greaseable</i>	UJ231
	U-Bolt Kit (Front)	UJ534-10		(For Aluminum Drive Shaft)	UJ331C
	U-Joint (Center)Ⓢ	UJ354		Clamp Kit (Front)	UJ331-10
	<i>Brute Force Greaseable</i>	UJ270		U-Joint (Center)Ⓢ	UJ331
	<i>Brute Force Non Greaseable</i>	UJ254		<i>Brute Force Greaseable</i>	UJ232
	(For Aluminum Drive Shaft)	UJ354C		<i>Brute Force Non Greaseable</i>	UJ231
	U-Joint (Rear)Ⓢ	UJ434		(For Aluminum Drive Shaft)	UJ331C
	<i>Brute Force Greaseable</i>	UJ265		Clamp Kit (Center)	UJ331-10
	<i>Brute Force Non Greaseable</i>	UJ264		U-Joint (Rear)Ⓢ	UJ331
	U-Bolt Kit (Rear)	UJ534-10		<i>Brute Force Greaseable</i>	UJ232
	1992-1990 F-250 w/ 3 Joint Shaft, Ext. Cab 5.8L Eng. & 4 Spd. Auto. Trans.: [Type 2]			<i>Brute Force Non Greaseable</i>	UJ231
	U-Joint (Front)Ⓢ	UJ331		(For Aluminum Drive Shaft)	UJ331C
	<i>Brute Force Greaseable</i>	UJ232		Clamp Kit (Center)	UJ331-10
	<i>Brute Force Non Greaseable</i>	UJ231		U-Joint (Rear)Ⓢ	UJ331
	(For Aluminum Drive Shaft)	UJ331C		<i>Brute Force Greaseable</i>	UJ232
	Clamp Kit (Front)	UJ331-10		<i>Brute Force Non Greaseable</i>	UJ231
	U-Joint (Center)Ⓢ	UJ331		(For Aluminum Drive Shaft)	UJ331C
	<i>Brute Force Greaseable</i>	UJ232		Clamp Kit (Rear)	UJ331-10
	<i>Brute Force Non Greaseable</i>	UJ231		U-Joint (Rear)Ⓢ	UJ331
	(For Aluminum Drive Shaft)	UJ331C		<i>Brute Force Greaseable</i>	UJ232
	Clamp Kit (Center)	UJ331-10		<i>Brute Force Non Greaseable</i>	UJ231
	U-Joint (Rear)Ⓢ	UJ331		(For Aluminum Drive Shaft)	UJ331C
	<i>Brute Force Greaseable</i>	UJ232		Clamp Kit (Rear)	UJ331-10
	<i>Brute Force Non Greaseable</i>	UJ231		1991 F-250 w/ 3 Joint Shaft, Reg. Cab & 5.0L Eng.: [Type 2]	
	(For Aluminum Drive Shaft)	UJ331C		U-Joint (Front)Ⓢ	UJ354
	Clamp Kit (Rear)	UJ331-10		<i>Brute Force Greaseable</i>	UJ270
	1992-1990 F-250 w/ 3 Joint Shaft, Ext. Cab, 5.8L Eng. & Man. Trans.: [Type 2]			<i>Brute Force Non Greaseable</i>	UJ254
	U-Joint (Front)Ⓢ	UJ434		(For Aluminum Drive Shaft)	UJ354C
	<i>Brute Force Greaseable</i>	UJ265		U-Joint (Center)Ⓢ	UJ354
	<i>Brute Force Non Greaseable</i>	UJ264		<i>Brute Force Greaseable</i>	UJ270
	U-Bolt Kit (Front)	UJ534-10		<i>Brute Force Non Greaseable</i>	UJ254
	U-Joint (Center)Ⓢ	UJ354		(For Aluminum Drive Shaft)	UJ354C
	<i>Brute Force Greaseable</i>	UJ270		U-Joint (Rear)Ⓢ	UJ434
	<i>Brute Force Non Greaseable</i>	UJ254		<i>Brute Force Greaseable</i>	UJ265
	(For Aluminum Drive Shaft)	UJ354C		<i>Brute Force Non Greaseable</i>	UJ264
	U-Joint (Rear)Ⓢ	UJ434		U-Bolt Kit (Rear)	UJ534-10
	<i>Brute Force Greaseable</i>	UJ265		1991 F-250 w/ 2 Joint Shaft, Reg. Cab, 5.0L Eng & Auto. Trans.: [Type 1]	
	<i>Brute Force Non Greaseable</i>	UJ264		U-Joint (Front)Ⓢ	UJ434
	U-Bolt Kit (Rear)	UJ534-10		<i>Brute Force Greaseable</i>	UJ265
	1991 F-250 w/ 2 Joint Shaft, Reg. Cab, 5.0L Eng & Man. Trans.: [Type 1]			<i>Brute Force Non Greaseable</i>	UJ264
	U-Joint (Front)Ⓢ	UJ354		U-Bolt Kit (Front)	UJ534-10
	<i>Brute Force Greaseable</i>	UJ270		U-Joint (Rear)Ⓢ	UJ434
	<i>Brute Force Non Greaseable</i>	UJ254		<i>Brute Force Greaseable</i>	UJ265
	(For Aluminum Drive Shaft)	UJ354C		<i>Brute Force Non Greaseable</i>	UJ264
	U-Joint (Rear)Ⓢ	UJ434		U-Bolt Kit (Rear)	UJ534-10
	<i>Brute Force Greaseable</i>	UJ265		1991 F-250 w/ 2 Joint Shaft, Reg. Cab, 5.0L Eng & Man. Trans.: [Type 1]	
	<i>Brute Force Non Greaseable</i>	UJ264		U-Joint (Front)Ⓢ	UJ354
	U-Bolt Kit (Rear)	UJ534-10		<i>Brute Force Greaseable</i>	UJ270
				<i>Brute Force Non Greaseable</i>	UJ254
				(For Aluminum Drive Shaft)	UJ354C
				U-Joint (Rear)Ⓢ	UJ434
				<i>Brute Force Greaseable</i>	UJ265
				<i>Brute Force Non Greaseable</i>	UJ264
				U-Bolt Kit (Rear)	UJ534-10

(Continued)

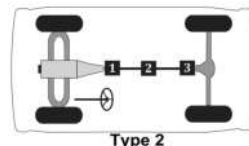
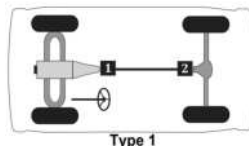

Passenger cars, light & medium trucks

Ford Truck 3/4 ton -- (Cont.)

MFG./YEAR	MODEL & LOCATION	PART NO.	MFG./YEAR	MODEL & LOCATION	PART NO.
Drive Shaft (2 W/D) (Cont.)			Drive Shaft (2 W/D) (Cont.)		
U-Joint (Cont.)			U-Joint (Cont.)		
1991-1990 F-250 w/ 2 Joint Shaft, Reg. Cab, 4.9L			1991-1990 F-250 w/ 3 Joint Shaft, Reg. Cab, 5.8L		
Eng. & 3 Spd. Auto. Trans.: [Type 1]			Eng & Man. Trans.. [Type 2]		
U-Joint (Front)ⓐ		UJ354	U-Joint (Front)ⓐ		UJ434
Brute Force Greaseable		UJ270	Brute Force Greaseable		UJ265
Brute Force Non Greaseable		UJ254	Brute Force Non Greaseable		UJ264
(For Aluminum Drive Shaft)		UJ354C	U-Bolt Kit (Front)		UJ534-10
U-Joint (Rear)ⓑ		UJ434	U-Joint (Center)ⓐ		UJ354
Brute Force Greaseable		UJ265	Brute Force Greaseable		UJ270
Brute Force Non Greaseable		UJ264	Brute Force Non Greaseable		UJ254
U-Bolt Kit (Rear)		UJ534-10	(For Aluminum Drive Shaft)		UJ354C
1991-1990 F-250 w/ 2 Joint Shaft, Reg. Cab, 4.9L			U-Joint (Rear)ⓑ		
Eng. & 4 Spd. Auto. Trans.: [Type 1]			Brute Force Greaseable		
U-Joint (Front)ⓐ		UJ434	UJ265		
Brute Force Greaseable		UJ265	Brute Force Non Greaseable		
Brute Force Non Greaseable		UJ264	UJ264		
U-Bolt Kit (Front)		UJ534-10	U-Bolt Kit (Rear)		
U-Joint (Rear)ⓑ		UJ434	UJ534-10		
Brute Force Greaseable		UJ265	1991-1990 F-250 w/ 2 Joint Shaft, Reg. Cab, 7.3L,		
Brute Force Non Greaseable		UJ264	7.5L Eng & Auto. Trans.: [Type 1]		
U-Bolt Kit (Rear)		UJ534-10	U-Joint (Front)ⓐ		
1991-1990 F-250 w/ 2 Joint Shaft, Reg. Cab, 4.9L			Brute Force Greaseable		
Eng. & 4 Spd. Man. Trans.: [Type 1]			UJ270		
U-Joint (Front)ⓐ		UJ354	Brute Force Non Greaseable		
Brute Force Greaseable		UJ270	UJ254		
Brute Force Non Greaseable		UJ264	U-Bolt Kit (Rear)		
(For Aluminum Drive Shaft)		UJ354C	UJ534-10		
U-Joint (Rear)ⓑ		UJ434	1991-1990 F-250 w/ 3 Joint Shaft, Reg. Cab, 7.3L,		
Brute Force Greaseable		UJ265	7.5L Eng & Man. Trans.: [Type 2]		
Brute Force Non Greaseable		UJ264	U-Joint (Front)ⓐ		
U-Bolt Kit (Rear)		UJ534-10	Brute Force Greaseable		
1991-1990 F-250 w/ 2 Joint Shaft, Reg. Cab, 4.9L			UJ270		
Eng. & Std. 5 Spd. Man. Trans.: [Type 1]			Brute Force Non Greaseable		
U-Joint (Front)ⓐ		UJ354	UJ231		
Brute Force Greaseable		UJ270	UJ331C		
Brute Force Non Greaseable		UJ254	(For Aluminum Drive Shaft)		
(For Aluminum Drive Shaft)		UJ354C	Clamp Kit (Front)		
U-Joint (Rear)ⓑ		UJ434	UJ331-10		
Brute Force Greaseable		UJ265	U-Joint (Center)ⓐ		
Brute Force Non Greaseable		UJ264	Brute Force Greaseable		
U-Bolt Kit (Rear)		UJ534-10	UJ232		
1991-1990 F-250 w/ 2 Joint Shaft, Reg. Cab, 5.8L			Brute Force Non Greaseable		
Eng & Auto. Trans.. [Type 1]			UJ231		
U-Joint (Front)ⓐ		UJ354	UJ331C		
Brute Force Greaseable		UJ270	(For Aluminum Drive Shaft)		
Brute Force Non Greaseable		UJ254	Clamp Kit (Center)		
(For Aluminum Drive Shaft)		UJ354C	UJ331-10		
U-Joint (Rear)ⓑ		UJ434	U-Joint (Rear)ⓑ		
Brute Force Greaseable		UJ265	Brute Force Greaseable		
Brute Force Non Greaseable		UJ264	UJ232		
U-Bolt Kit (Rear)		UJ534-10	Brute Force Non Greaseable		
1991-1990 F-250 w/ 2 Joint Shaft, Reg. Cab, 5.8L			UJ231		
Eng & Auto. Trans.. [Type 1]			(For Aluminum Drive Shaft)		
U-Joint (Front)ⓐ		UJ354	UJ331C		
Brute Force Greaseable		UJ270	Clamp Kit (Rear)		
Brute Force Non Greaseable		UJ254	UJ331-10		
(For Aluminum Drive Shaft)		UJ354C	1990 F-250 w/ 2 Joint Shaft, Reg. Cab, 5.0L		
U-Joint (Rear)ⓑ		UJ434	Eng & C6 3 Spd. Auto. Trans.: [Type 1]		
Brute Force Greaseable		UJ265	U-Joint (Front)ⓐ		
Brute Force Non Greaseable		UJ264	Brute Force Greaseable		
U-Bolt Kit (Rear)		UJ534-10	UJ265		
			Brute Force Non Greaseable		
			UJ264		
			U-Bolt Kit (Front)		
			UJ534-10		
			U-Joint (Rear)ⓑ		
			Brute Force Greaseable		
			UJ434		
			Brute Force Non Greaseable		
			UJ265		
			Brute Force Non Greaseable		
			UJ264		
			U-Bolt Kit (Rear)		
			UJ534-10		

(Continued)

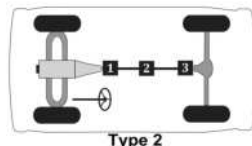
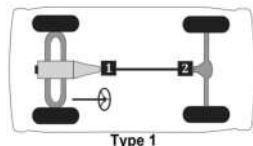

390 ▲ For Use w/ 1.063" Bearing Cap Application. ⓐ For Use w/ 1.188" Bearing Cap Application. ◇ For Use w/ Inner Lock Ring Application on Half Shaft. □ For Use w/ Outer Lock Ring Application on Half Shaft.



MFG./YEAR	MODEL & LOCATION	PART NO.	MFG./YEAR	MODEL & LOCATION	PART NO.
Drive Shaft (2 W/D) (Cont.)			Drive Shaft (2 W/D) (Cont.)		
U-Joint (Cont.)			U-Joint (Cont.)		
1990	F-250 w/ 2 Joint Shaft, Reg. Cab, 5.0L Eng Exc. C6 3 Spd. Auto. Trans.: [Type 1]		1990	F-250 w/ 3 Joint Shaft, Ext. Cab, 5.8L Eng. & 3 Spd. Auto. Trans.: [Type 2]	
	U-Joint (Front)Ⓢ	UJ354		U-Joint (Front)Ⓢ	UJ354
	<i>Brute Force Greaseable</i>	UJ270		<i>Brute Force Greaseable</i>	UJ270
	<i>Brute Force Non Greaseable</i>	UJ254		<i>Brute Force Non Greaseable</i>	UJ254
	(For Aluminum Drive Shaft)	UJ354C		(For Aluminum Drive Shaft)	UJ354C
	U-Joint (Rear)Ⓢ	UJ434		U-Joint (Center)Ⓢ	UJ354
	<i>Brute Force Greaseable</i>	UJ265		<i>Brute Force Greaseable</i>	UJ270
	<i>Brute Force Non Greaseable</i>	UJ264		<i>Brute Force Non Greaseable</i>	UJ254
	(For Aluminum Drive Shaft)	UJ354C		(For Aluminum Drive Shaft)	UJ354C
	U-Bolt Kit (Rear)	UJ534-10		U-Joint (Rear)Ⓢ	UJ434
1990	F-250 w/ 3 Joint Shaft, Reg. Cab & 5.0L Eng.: [Type 2]			<i>Brute Force Greaseable</i>	UJ265
	U-Joint (Front)Ⓢ	UJ354		<i>Brute Force Non Greaseable</i>	UJ264
	<i>Brute Force Greaseable</i>	UJ270		U-Bolt Kit (Rear)	UJ534-10
	<i>Brute Force Non Greaseable</i>	UJ254		1989-1988 F-250 w/ 2 Joint Shaft & HD 5 Spd.	
	(For Aluminum Drive Shaft)	UJ354C		Man. Trans.: [Type 1]	
	U-Joint (Center)Ⓢ	UJ354		U-Joint (Front)Ⓢ	UJ331
	<i>Brute Force Greaseable</i>	UJ270		<i>Brute Force Greaseable</i>	UJ232
	<i>Brute Force Non Greaseable</i>	UJ254		<i>Brute Force Non Greaseable</i>	UJ231
	(For Aluminum Drive Shaft)	UJ354C		(For Aluminum Drive Shaft)	UJ331C
	U-Joint (Rear)Ⓢ	UJ434		Clamp Kit (Front)	UJ331-10
	<i>Brute Force Greaseable</i>	UJ265		U-Joint (Rear)Ⓢ	UJ331
	<i>Brute Force Non Greaseable</i>	UJ264		<i>Brute Force Greaseable</i>	UJ232
	U-Bolt Kit (Rear)	UJ534-10		<i>Brute Force Non Greaseable</i>	UJ231
1990	F-250 w/ 3 Joint Shaft, Ext. Cab & 4.9L Eng.: [Type 2]			(For Aluminum Drive Shaft)	UJ331C
	U-Joint (Front)Ⓢ	UJ434		Clamp Kit (Rear)	UJ331-10
	<i>Brute Force Greaseable</i>	UJ265		1989-1988 F-250 w/ 2 Joint Shaft Exc. HD 5 Spd.	
	<i>Brute Force Non Greaseable</i>	UJ264		Man. Trans.: [Type 1]	
	U-Bolt Kit (Front)	UJ534-10		U-Joint (Front)Ⓢ	UJ354
	U-Joint (Center)Ⓢ	UJ354		<i>Brute Force Greaseable</i>	UJ270
	<i>Brute Force Greaseable</i>	UJ270		<i>Brute Force Non Greaseable</i>	UJ254
	<i>Brute Force Non Greaseable</i>	UJ254		(For Aluminum Drive Shaft)	UJ354C
	(For Aluminum Drive Shaft)	UJ354C		U-Joint (Rear)Ⓢ	UJ434
	U-Joint (Rear)Ⓢ	UJ434		<i>Brute Force Greaseable</i>	UJ265
	<i>Brute Force Greaseable</i>	UJ265		<i>Brute Force Non Greaseable</i>	UJ264
	<i>Brute Force Non Greaseable</i>	UJ264		U-Bolt Kit (Rear)	UJ534-10
	U-Bolt Kit (Rear)	UJ534-10		1989-1988 F-250 w/ 3 Joint Shaft & HD 5 Spd.	
				Man. Trans.: [Type 2]	
				U-Joint (Front)Ⓢ	UJ331
				<i>Brute Force Greaseable</i>	UJ232
				<i>Brute Force Non Greaseable</i>	UJ231
				(For Aluminum Drive Shaft)	UJ331C
				Clamp Kit (Front)	UJ331-10
				U-Joint (Center)Ⓢ	UJ354
				<i>Brute Force Greaseable</i>	UJ270
				<i>Brute Force Non Greaseable</i>	UJ254
				(For Aluminum Drive Shaft)	UJ354C
				U-Joint (Rear)Ⓢ	UJ331
				<i>Brute Force Greaseable</i>	UJ232
				<i>Brute Force Non Greaseable</i>	UJ231
				(For Aluminum Drive Shaft)	UJ331C
				Clamp Kit (Rear)	UJ331-10

(Continued)

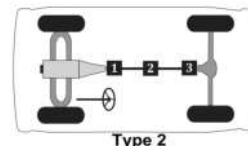
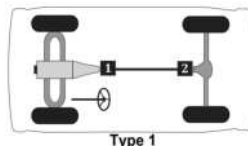

Passenger cars, light & medium trucks

Ford Truck 3/4 ton -- (Cont.)

MFG./YEAR	MODEL & LOCATION	PART NO.	MFG./YEAR	MODEL & LOCATION	PART NO.
Drive Shaft (2 W/D) (Cont.)			Drive Shaft (2 W/D) (Cont.)		
U-Joint (Cont.)			U-Joint (Cont.)		
1989-1988 F-250 w/ 3 Joint Shaft Exc. HD 5 Spd.			1986-1980 F-250 w/ 3 Joint Shaft: [Type 2]		
Man. Trans.: [Type 2]					
U-Joint (Front)Ⓛ		UJ354	U-Joint (Front)Ⓛ		UJ354
<i>Brute Force Greaseable</i>		UJ270	<i>Brute Force Greaseable</i>		UJ270
<i>Brute Force Non Greaseable</i>		UJ254	<i>Brute Force Non Greaseable</i>		UJ254
(For Aluminum Drive Shaft)		UJ354C	(For Aluminum Drive Shaft)		UJ354C
U-Joint (Center)Ⓛ		UJ354	U-Joint (Center)Ⓛ		UJ354
<i>Brute Force Greaseable</i>		UJ270	<i>Brute Force Greaseable</i>		UJ270
<i>Brute Force Non Greaseable</i>		UJ254	<i>Brute Force Non Greaseable</i>		UJ254
(For Aluminum Drive Shaft)		UJ354C	(For Aluminum Drive Shaft)		UJ354C
U-Joint (Rear)Ⓛ		UJ434	U-Joint (Rear)Ⓛ		UJ434
<i>Brute Force Greaseable</i>		UJ265	<i>Brute Force Greaseable</i>		UJ265
<i>Brute Force Non Greaseable</i>		UJ264	<i>Brute Force Non Greaseable</i>		UJ264
U-Bolt Kit (Rear)		UJ534-10	U-Bolt Kit (Rear)		UJ534-10
1987 F-250 w/ 5 Spd. Man. Trans.: [Type 1]			1979 F-250 w/ 133" & 138" Wheel Base & 3.73 Rear Axle Ratio Exc. 400 Eng.: [Type 2]		
U-Joint (Front)Ⓛ		UJ331	U-Joint (Front)Ⓛ		UJ354
<i>Brute Force Greaseable</i>		UJ232	<i>Brute Force Greaseable</i>		UJ270
<i>Brute Force Non Greaseable</i>		UJ231	<i>Brute Force Non Greaseable</i>		UJ254
(For Aluminum Drive Shaft)		UJ331C	(For Aluminum Drive Shaft)		UJ354C
Clamp Kit (Front)		UJ331-10	U-Joint (Center)Ⓛ		UJ354
U-Joint (Rear)Ⓛ		UJ331	<i>Brute Force Greaseable</i>		UJ270
<i>Brute Force Greaseable</i>		UJ232	<i>Brute Force Non Greaseable</i>		UJ254
<i>Brute Force Non Greaseable</i>		UJ231	(For Aluminum Drive Shaft)		UJ354C
(For Aluminum Drive Shaft)		UJ331C	U-Joint (Rear)Ⓛ		UJ434
Clamp Kit (Rear)		UJ331-10	<i>Brute Force Greaseable</i>		UJ265
1987 F-250 w/o 5 Spd. Man. Trans.: [Type 1]			<i>Brute Force Non Greaseable</i>		UJ264
U-Joint (Front)Ⓛ		UJ354	U-Bolt Kit (Rear)		UJ534-10
<i>Brute Force Greaseable</i>		UJ270	1979 F-250 w/ 133" & 138" Wheel Base Exc. 3.73 Rear Axle Ratio & 400 Eng.: [Type 2]		
<i>Brute Force Non Greaseable</i>		UJ254	U-Joint (Front)Ⓛ		UJ354
(For Aluminum Drive Shaft)		UJ354C	<i>Brute Force Greaseable</i>		UJ270
U-Joint (Rear)Ⓛ		UJ434	<i>Brute Force Non Greaseable</i>		UJ254
<i>Brute Force Greaseable</i>		UJ265	(For Aluminum Drive Shaft)		UJ354C
<i>Brute Force Non Greaseable</i>		UJ264	U-Joint (Center)Ⓛ		UJ354
U-Bolt Kit (Rear)		UJ534-10	<i>Brute Force Greaseable</i>		UJ270
1986-1980 F-250 w/ 2 Joint Shaft: [Type 1]			<i>Brute Force Non Greaseable</i>		UJ254
U-Joint (Front)Ⓛ		UJ354	(For Aluminum Drive Shaft)		UJ354C
<i>Brute Force Greaseable</i>		UJ270	U-Joint (Rear)Ⓛ		UJ331
<i>Brute Force Non Greaseable</i>		UJ254	<i>Brute Force Greaseable</i>		UJ232
(For Aluminum Drive Shaft)		UJ354C	<i>Brute Force Non Greaseable</i>		UJ231
U-Joint (Rear)Ⓛ		UJ434	(For Aluminum Drive Shaft)		UJ331C
<i>Brute Force Greaseable</i>		UJ265	U-Bolt Kit (Rear)		UJ330-10
<i>Brute Force Non Greaseable</i>		UJ264			
U-Bolt Kit (Rear)		UJ534-10			

(Continued)

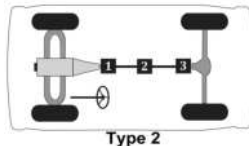
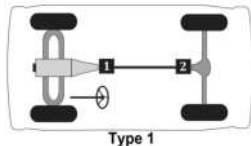

MFG./YEAR	MODEL & LOCATION	PART NO.	MFG./YEAR	MODEL & LOCATION	PART NO.
Drive Shaft (2 W/D) (Cont.)			Drive Shaft (2 W/D) (Cont.)		
U-Joint (Cont.)			U-Joint (Cont.)		
1979	F-250 w/ 150" Wheel Base Exc. 400 Eng.: [Type 2]		1978	F-250 w/ 3 Joint Shaft, 400 & 460 Eng.: [Type 2]	
	U-Joint (Front)⓪	UJ354		U-Joint (Front)⓪	UJ354
	Brute Force Greaseable	UJ270		Brute Force Greaseable	UJ270
	Brute Force Non Greaseable	UJ254		Brute Force Non Greaseable	UJ254
	(For Aluminum Drive Shaft)	UJ354C		(For Aluminum Drive Shaft)	UJ354C
	U-Joint (Center)⓪	UJ331		U-Joint (Center)⓪	▲ UJ354
	Brute Force Greaseable	UJ232		Brute Force Greaseable	UJ270
	Brute Force Non Greaseable	UJ231		Brute Force Non Greaseable	UJ254
	(For Aluminum Drive Shaft)	UJ331C		(For Aluminum Drive Shaft)	UJ354C
	U-Bolt Kit (Center)	UJ330-10		Clamp Kit (Center)	UJ331-10
	U-Joint (Rear)⓪	UJ331		U-Joint (Rear)⓪	⊙ UJ331
	Brute Force Greaseable	UJ232		Brute Force Greaseable	UJ232
	Brute Force Non Greaseable	UJ231		Brute Force Non Greaseable	UJ231
	(For Aluminum Drive Shaft)	UJ331C		(For Aluminum Drive Shaft)	UJ331C
	U-Bolt Kit (Rear)	UJ330-10		U-Joint (Rear)⓪	UJ354
1979	F-250 w/ 400 Eng.: [Type 2]			Brute Force Greaseable	UJ270
	U-Joint (Front)⓪	UJ331		Brute Force Non Greaseable	UJ254
	Brute Force Greaseable	UJ232		(For Aluminum Drive Shaft)	UJ354C
	Brute Force Non Greaseable	UJ231		1977 F-250 w/ 3.5" Yoke, 300 & 351 Eng.: [Type 2]	
	(For Aluminum Drive Shaft)	UJ331C		U-Joint (Front)⓪	UJ369
	Clamp Kit (Front)	UJ331-10		Brute Force Greaseable	UJ280
	U-Joint (Center)⓪	UJ331		Brute Force Non Greaseable	UJ269
	Brute Force Greaseable	UJ232		(For Aluminum Drive Shaft)	UJ369C
	Brute Force Non Greaseable	UJ231		U-Joint (Center)⓪	UJ369
	(For Aluminum Drive Shaft)	UJ331C		Brute Force Greaseable	UJ280
	Clamp Kit (Center)	UJ331-10		Brute Force Non Greaseable	UJ269
	U-Joint (Rear)⓪	UJ331		(For Aluminum Drive Shaft)	UJ369C
	Brute Force Greaseable	UJ232		U-Joint (Rear)⓪	UJ369
	Brute Force Non Greaseable	UJ231		Brute Force Greaseable	UJ280
	(For Aluminum Drive Shaft)	UJ331C		Brute Force Non Greaseable	UJ269
	Clamp Kit (Rear)	UJ331-10		(For Aluminum Drive Shaft)	UJ369C
1978	F-250 w/ 300 & 351 Eng.: [Type 2]		1977	F-250 w/ 3.875" Yoke, 300 & 351 Eng.: [Type 2]	
	U-Joint (Front)⓪	UJ369		U-Joint (Front)⓪	UJ353
	Brute Force Greaseable	UJ280		Brute Force Greaseable	UJ275
	Brute Force Non Greaseable	UJ269		U-Joint (Center)⓪	UJ353
	(For Aluminum Drive Shaft)	UJ369C		Brute Force Greaseable	UJ275
	U-Joint (Center)⓪	UJ369		U-Joint (Rear)⓪	UJ353
	Brute Force Greaseable	UJ280		Brute Force Greaseable	UJ275
	Brute Force Non Greaseable	UJ269		1977 F-250 w/ 2 Joint Shaft, 133" Wheel Base, 400 & 460 Eng.: [Type 2]	
	(For Aluminum Drive Shaft)	UJ369C		U-Joint (Front)⓪	UJ331
	U-Joint (Rear)⓪	UJ369		Brute Force Greaseable	UJ232
	Brute Force Greaseable	UJ280		Brute Force Non Greaseable	UJ231
	Brute Force Non Greaseable	UJ269		(For Aluminum Drive Shaft)	UJ331C
	(For Aluminum Drive Shaft)	UJ369C		Clamp Kit (Front)	UJ331-10
1978	F-250 w/ 2 Joint Shaft, 400 & 460 Eng.: [Type 1]			U-Joint (Center)⓪	UJ331
	U-Joint (Front)⓪	UJ354		Brute Force Greaseable	UJ232
	Brute Force Greaseable	UJ270		Brute Force Non Greaseable	UJ231
	Brute Force Non Greaseable	UJ254		(For Aluminum Drive Shaft)	UJ331C
	(For Aluminum Drive Shaft)	UJ354C		Clamp Kit (Center)	UJ331-10
	U-Joint (Rear)⓪	UJ354			
	Brute Force Greaseable	UJ270			
	Brute Force Non Greaseable	UJ254			
	(For Aluminum Drive Shaft)	UJ354C			

(Continued)

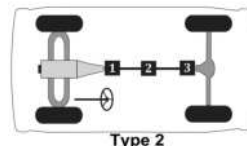
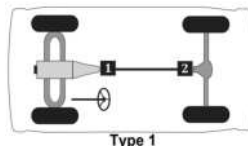

Passenger cars, light & medium trucks

Ford Truck 3/4 ton -- (Cont.)

MFG./YEAR	MODEL & LOCATION	PART NO.	MFG./YEAR	MODEL & LOCATION	PART NO.
Drive Shaft (2 W/D) (Cont.)			Drive Shaft (2 W/D) (Cont.)		
U-Joint (Cont.)			U-Joint (Cont.)		
1977	F-250 w/ 3 Joint Shaft, 133" & 138" Wheel Base, 1.063" Dia. Brg. Cap, 400 & 460 Engs.: [Type 2]		1977	F-250 w/ 3 Joint Shaft, 133" & 138" Wheel Base, 1.188" Dia. Brg. Cap, 400 & 460 Engs.: [Type 2]	
U-Joint (Front)ⓐ		UJ354	U-Joint (Front)ⓐ		UJ331
Brute Force Greaseable		UJ270	Brute Force Greaseable		UJ232
Brute Force Non Greaseable		UJ254	Brute Force Non Greaseable		UJ231
(For Aluminum Drive Shaft)		UJ354C	(For Aluminum Drive Shaft)		UJ331C
U-Joint (Center)ⓑ		UJ354	Clamp Kit (Front)		UJ331-10
Brute Force Greaseable		UJ270	U-Joint (Center)ⓑ		UJ331
Brute Force Non Greaseable		UJ254	Brute Force Greaseable		UJ232
(For Aluminum Drive Shaft)		UJ354C	Brute Force Non Greaseable		UJ231
U-Joint (Rear)ⓐ		UJ331	(For Aluminum Drive Shaft)		UJ331C
Brute Force Greaseable		UJ232	Clamp Kit (Center)		UJ331-10
Brute Force Non Greaseable		UJ231	U-Joint (Rear)ⓐ		UJ331
(For Aluminum Drive Shaft)		UJ331C	Brute Force Greaseable		UJ232
Clamp Kit (Rear)		UJ331-10	Brute Force Non Greaseable		UJ231
1977	F-250 w/ 3 Joint Shaft, 133" & 138" Wheel Base, 1.188" Dia. Brg. Cap, 400 & 460 Engs.: [Type 2]		(For Aluminum Drive Shaft)		UJ331C
U-Joint (Front)ⓐ		UJ331	Clamp Kit (Rear)		UJ331-10
Brute Force Greaseable		UJ232	1977	F-250 w/ 150" & 155" Wheel Base, 3.5" Yoke, 400 & 460 Engs.: [Type 2]	
Brute Force Non Greaseable		UJ231	U-Joint (Front)ⓐ		UJ369
(For Aluminum Drive Shaft)		UJ331C	Brute Force Greaseable		UJ280
Clamp Kit (Front)		UJ331-10	Brute Force Non Greaseable		UJ269
U-Joint (Center)ⓑ		UJ331	(For Aluminum Drive Shaft)		UJ369C
Brute Force Greaseable		UJ232	U-Joint (Center)ⓑ		UJ369
Brute Force Non Greaseable		UJ231	Brute Force Greaseable		UJ280
(For Aluminum Drive Shaft)		UJ331C	Brute Force Non Greaseable		UJ269
Clamp Kit (Center)		UJ331-10	(For Aluminum Drive Shaft)		UJ369C
U-Joint (Rear)ⓐ		UJ331	U-Joint (Rear)ⓐ		UJ369
Brute Force Greaseable		UJ232	Brute Force Greaseable		UJ280
Brute Force Non Greaseable		UJ231	Brute Force Non Greaseable		UJ269
(For Aluminum Drive Shaft)		UJ331C	(For Aluminum Drive Shaft)		UJ369C
Clamp Kit (Rear)		UJ331-10	1977	F-250 w/ 150" & 155" Wheel Base, 3.875" Yoke, 1.063" Dia. Brg. Cap, 400 & 460 Engs.: [Type 2]	
1977	F-250 w/ 3 Joint Shaft, 133" & 138" Wheel Base, 1.063" Dia. Brg. Cap, 400 & 460 Engs.: [Type 2]		U-Joint (Front)ⓐ		UJ354
U-Joint (Front)ⓐ		UJ354	Brute Force Greaseable		UJ270
Brute Force Greaseable		UJ270	Brute Force Non Greaseable		UJ254
Brute Force Non Greaseable		UJ254	(For Aluminum Drive Shaft)		UJ354C
(For Aluminum Drive Shaft)		UJ354C	U-Joint (Center)ⓑ		UJ354
U-Joint (Center)ⓑ		UJ354	Brute Force Greaseable		UJ270
Brute Force Greaseable		UJ270	Brute Force Non Greaseable		UJ254
Brute Force Non Greaseable		UJ254	(For Aluminum Drive Shaft)		UJ354C
(For Aluminum Drive Shaft)		UJ354C	U-Joint (Rear)ⓐ		UJ354
U-Joint (Rear)ⓐ		UJ331	Brute Force Greaseable		UJ270
Brute Force Greaseable		UJ232	Brute Force Non Greaseable		UJ254
Brute Force Non Greaseable		UJ231	(For Aluminum Drive Shaft)		UJ354C
(For Aluminum Drive Shaft)		UJ331C			(Continued)
Clamp Kit (Rear)		UJ331-10			

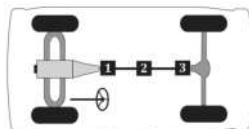

Type 2

SKF

Passenger cars, light & medium trucks

(Cont.) -- Ford Truck 3/4 ton

MFG./YEAR	MODEL & LOCATION	PART NO.	MFG./YEAR	MODEL & LOCATION	PART NO.
Drive Shaft (2 W/D) (Cont.)			Drive Shaft (2 W/D) (Cont.)		
U-Joint (Cont.)			U-Joint (Cont.)		
1977	F-250 w/ 150" & 155" Wheel Base, 3.875" Yoke, 1.188" Dia. Brg. Cap, 400 & 460 Engs.: [Type 2]		1976-1975	F-250 w/ 2 Joint Shaft, 133" Wheel Base, 390 & 460 Engs.: [Type 1]	
	U-Joint (Front)⓪	UJ331		U-Joint (Front)⓪	UJ331
	<i>Brute Force Greaseable</i>	UJ232		<i>Brute Force Greaseable</i>	UJ232
	<i>Brute Force Non Greaseable</i>	UJ231		<i>Brute Force Non Greaseable</i>	UJ231
	(For Aluminum Drive Shaft)	UJ331C		(For Aluminum Drive Shaft)	UJ331C
	Clamp Kit (Front)	UJ331-10		Clamp Kit (Front)	UJ331-10
	U-Joint (Center)⓪	UJ331		U-Joint (Rear)⓪	UJ331
	<i>Brute Force Greaseable</i>	UJ232		<i>Brute Force Greaseable</i>	UJ232
	<i>Brute Force Non Greaseable</i>	UJ231		<i>Brute Force Non Greaseable</i>	UJ231
	(For Aluminum Drive Shaft)	UJ331C		(For Aluminum Drive Shaft)	UJ331C
	Clamp Kit (Center)	UJ331-10		Clamp Kit (Rear)	UJ331-10
	U-Joint (Rear)⓪	UJ331		1976-1975 F-250 w/ 3 Joint Shaft, 133" & 138"	
	<i>Brute Force Greaseable</i>	UJ232		Wheel Base, 1.063" Dia. Brg. Cap, 390	
	<i>Brute Force Non Greaseable</i>	UJ231		& 460 Engs.: [Type 2]	
	(For Aluminum Drive Shaft)	UJ331C		U-Joint (Front)⓪	UJ354
	Clamp Kit (Rear)	UJ331-10		<i>Brute Force Greaseable</i>	UJ270
	1976-1975 F-250 w/ Ext. Cab, Man. Trans, 300 &			<i>Brute Force Non Greaseable</i>	UJ254
	360 Engs.: [Type 2]			(For Aluminum Drive Shaft)	UJ354C
	U-Joint (Front)⓪	UJ369		U-Joint (Center)⓪	UJ354
	<i>Brute Force Greaseable</i>	UJ280		<i>Brute Force Greaseable</i>	UJ270
	<i>Brute Force Non Greaseable</i>	UJ269		<i>Brute Force Non Greaseable</i>	UJ254
	(For Aluminum Drive Shaft)	UJ369C		(For Aluminum Drive Shaft)	UJ354C
	U-Joint (Center)⓪	UJ353		U-Joint (Rear)⓪	UJ331
	<i>Brute Force Greaseable</i>	UJ275		<i>Brute Force Greaseable</i>	UJ232
	U-Joint (Rear)⓪	UJ353		<i>Brute Force Non Greaseable</i>	UJ231
	<i>Brute Force Greaseable</i>	UJ275		(For Aluminum Drive Shaft)	UJ331C
	1976-1975 F-250 w/ 300 & 360 Engs. Exc. Ext.			Clamp Kit (Rear)	UJ331-10
	Cab w/ Man. Trans.: [Type 2]			1976-1975 F-250 w/ 3 Joint Shaft, 133" & 138"	
	U-Joint (Front)⓪	UJ369		Wheel Base, 1.188" Dia. Brg. Cap, 390	
	<i>Brute Force Greaseable</i>	UJ280		& 460 Engs.: [Type 2]	
	<i>Brute Force Non Greaseable</i>	UJ269		U-Joint (Front)⓪	UJ331
	(For Aluminum Drive Shaft)	UJ369C		<i>Brute Force Greaseable</i>	UJ232
	U-Joint (Center)⓪	UJ369		<i>Brute Force Non Greaseable</i>	UJ231
	<i>Brute Force Greaseable</i>	UJ280		(For Aluminum Drive Shaft)	UJ331C
	<i>Brute Force Non Greaseable</i>	UJ269		Clamp Kit (Front)	UJ331-10
	(For Aluminum Drive Shaft)	UJ369C		U-Joint (Center)⓪	UJ331
	U-Joint (Rear)⓪	UJ369		<i>Brute Force Greaseable</i>	UJ232
	<i>Brute Force Greaseable</i>	UJ280		<i>Brute Force Non Greaseable</i>	UJ231
	<i>Brute Force Non Greaseable</i>	UJ269		(For Aluminum Drive Shaft)	UJ331C
	(For Aluminum Drive Shaft)	UJ369C		Clamp Kit (Center)	UJ331-10
	U-Joint (Rear)⓪	UJ369		U-Joint (Rear)⓪	UJ331
	<i>Brute Force Greaseable</i>	UJ280		<i>Brute Force Greaseable</i>	UJ232
	<i>Brute Force Non Greaseable</i>	UJ269		<i>Brute Force Non Greaseable</i>	UJ231
	(For Aluminum Drive Shaft)	UJ369C		(For Aluminum Drive Shaft)	UJ331C
				Clamp Kit (Rear)	UJ331-10

(Continued)

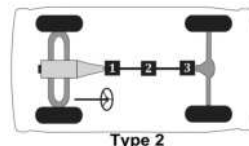
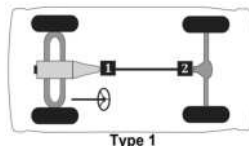

Passenger cars, light & medium trucks

Ford Truck 3/4 ton -- (Cont.)

MFG./YEAR	MODEL & LOCATION	PART NO.	MFG./YEAR	MODEL & LOCATION	PART NO.
Drive Shaft (2 W/D) (Cont.)			Drive Shaft (2 W/D) (Cont.)		
U-Joint (Cont.)			U-Joint (Cont.)		
1976-1975 F-250 w/ 150" & 155" Wheel Base, 3.5" Yoke, 390 & 460 Eng.s.: [Type 2]			1974-1973 F-250 w/ 300 & 360 Eng.s.: [Type 2]		
U-Joint (Front)Ⓚ		UJ369	U-Joint (Front)Ⓚ		UJ369
Brute Force Greaseable		UJ280	Brute Force Greaseable		UJ280
Brute Force Non Greaseable		UJ269	Brute Force Non Greaseable		UJ269
(For Aluminum Drive Shaft)		UJ369C	(For Aluminum Drive Shaft)		UJ369C
U-Joint (Center)Ⓚ		UJ369	U-Joint (Center)Ⓚ		UJ369
Brute Force Greaseable		UJ280	Brute Force Greaseable		UJ280
Brute Force Non Greaseable		UJ269	Brute Force Non Greaseable		UJ269
(For Aluminum Drive Shaft)		UJ369C	(For Aluminum Drive Shaft)		UJ369C
U-Joint (Rear)Ⓚ		UJ369	U-Joint (Rear)Ⓚ		UJ369
Brute Force Greaseable		UJ280	Brute Force Greaseable		UJ280
Brute Force Non Greaseable		UJ269	Brute Force Non Greaseable		UJ269
(For Aluminum Drive Shaft)		UJ369C	(For Aluminum Drive Shaft)		UJ369C
1976-1975 F-250 w/ 150" & 155" Wheel Base, 3.875" Yoke, 1.063" Dia. Brg. Cap, 390 & 460 Eng.s.: [Type 2]			1974-1968 F-250 w/ 390 & 460 Eng.s.: [Type 2]		
U-Joint (Front)Ⓚ		UJ354	U-Joint (Front)Ⓚ		UJ369
Brute Force Greaseable		UJ270	Brute Force Greaseable		UJ280
Brute Force Non Greaseable		UJ254	Brute Force Non Greaseable		UJ269
(For Aluminum Drive Shaft)		UJ354C	(For Aluminum Drive Shaft)		UJ369C
U-Joint (Center)Ⓚ		UJ354	U-Joint (Center)Ⓚ		UJ354
Brute Force Greaseable		UJ270	Brute Force Greaseable		UJ270
Brute Force Non Greaseable		UJ254	Brute Force Non Greaseable		UJ254
(For Aluminum Drive Shaft)		UJ354C	(For Aluminum Drive Shaft)		UJ354C
U-Joint (Rear)Ⓚ		UJ354	U-Joint (Rear)Ⓚ		UJ354
Brute Force Greaseable		UJ270	Brute Force Greaseable		UJ270
Brute Force Non Greaseable		UJ254	Brute Force Non Greaseable		UJ254
(For Aluminum Drive Shaft)		UJ354C	(For Aluminum Drive Shaft)		UJ354C
1976-1975 F-250 w/ 150" & 155" Wheel Base, 3.875" Yoke, 1.188" Dia. Brg. Cap, 390 & 460 Eng.s.: [Type 2]			1972-1968 F-250 w/ 240, 300 & 360 Eng.s.: [Type 2]		
U-Joint (Front)Ⓚ		UJ331	U-Joint (Front)Ⓚ		UJ369
Brute Force Greaseable		UJ232	Brute Force Greaseable		UJ280
Brute Force Non Greaseable		UJ231	Brute Force Non Greaseable		UJ269
(For Aluminum Drive Shaft)		UJ331C	(For Aluminum Drive Shaft)		UJ369C
Clamp Kit (Front)		UJ331-10	U-Joint (Center)Ⓚ		UJ369
U-Joint (Center)Ⓚ		UJ331	Brute Force Greaseable		UJ280
Brute Force Greaseable		UJ232	Brute Force Non Greaseable		UJ269
Brute Force Non Greaseable		UJ231	(For Aluminum Drive Shaft)		UJ369C
(For Aluminum Drive Shaft)		UJ331C	U-Joint (Rear)Ⓚ		UJ369
Clamp Kit (Center)		UJ331-10	Brute Force Greaseable		UJ280
U-Joint (Rear)Ⓚ		UJ331	Brute Force Non Greaseable		UJ269
Brute Force Greaseable		UJ232	(For Aluminum Drive Shaft)		UJ369C
Brute Force Non Greaseable		UJ231	1967-1953 F-250 w/ 2 Joint Shaft: [Type 1]		
(For Aluminum Drive Shaft)		UJ331C	U-Joint (Front)Ⓚ		UJ369
Clamp Kit (Rear)		UJ331-10	Brute Force Greaseable		UJ280
			Brute Force Non Greaseable		UJ269
			(For Aluminum Drive Shaft)		UJ369C
			U-Joint (Rear)Ⓚ		UJ369
			Brute Force Greaseable		UJ280
			Brute Force Non Greaseable		UJ269
			(For Aluminum Drive Shaft)		UJ369C

(Continued)

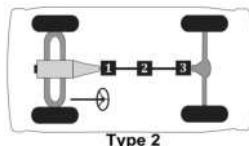
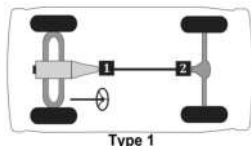

MFG./YEAR	MODEL & LOCATION	PART NO.	MFG./YEAR	MODEL & LOCATION	PART NO.
Drive Shaft (2 W/D) (Cont.)			Drive Shaft (4 W/D) (Cont.)		
U-Joint (Cont.)			U-Joint (Cont.)		
1967-1953 F-250 w/ 3 Joint Shaft: [Type 2]			2017-2011 F-250 Super Duty w/ 2 Joint Shaft & Narrow Frt. Axle Design: [Type 26]		
	U-Joint (Front)❶	UJ369		U-Joint (Frt. Shaft; Frt.)❶	UJ330
	Brute Force Greaseable	UJ280		Brute Force Greaseable	UJ295
	Brute Force Non Greaseable	UJ269		(For Aluminum Drive Shaft)	UJ330C
	(For Aluminum Drive Shaft)	UJ369C		Clamp Kit (Frt. Shaft; Frt.)	UJ331-10
	U-Joint (Center)❷	UJ369		U-Joint (Frt. Shaft; Rr.)❷	UJ331
	Brute Force Greaseable	UJ280		Brute Force Greaseable	UJ232
	Brute Force Non Greaseable	UJ269		Brute Force Non Greaseable	UJ231
	(For Aluminum Drive Shaft)	UJ369C		(For Aluminum Drive Shaft)	UJ331C
	U-Joint (Rear)❸	UJ369		U-Joint (Rr. Shaft; Frt.)❸	UJ330
	Brute Force Greaseable	UJ280		Brute Force Greaseable	UJ295
	Brute Force Non Greaseable	UJ269		(For Aluminum Drive Shaft)	UJ330C
	(For Aluminum Drive Shaft)	UJ369C		Clamp Kit (Rr. Shaft; Frt.)	UJ331-10
Drive Shaft (4 W/D)				U-Joint (Rr. Shaft; Rr.)❹	UJ330
U-Joint				Brute Force Greaseable	UJ295
2020-2018 F-250 Super Duty w/ 2 Joint Rear Shaft: [Type 26]				(For Aluminum Drive Shaft)	UJ330C
	U-Joint (Frt. Shaft; Frt.)❶	UJ330		Clamp Kit (Rr. Shaft; Rr.)	UJ331-10
	Brute Force Greaseable	UJ295		U-Joint (Wheel Joint)❺	UJ374
	(For Aluminum Drive Shaft)	UJ330C		Brute Force Non Greaseable	UJ374BF
	U-Joint (Frt. Shaft; Rr.)❷	UJ330	2017-2011 F-250 Super Duty w/ 3 Joint Shaft & Narrow Frt. Axle Design: [Type 27]		
	Brute Force Greaseable	UJ295		U-Joint (Frt. Shaft; Frt.)❶	UJ330
	(For Aluminum Drive Shaft)	UJ330C		Brute Force Greaseable	UJ295
	U-Joint (Rr. Shaft; Frt.)❸	UJ330		(For Aluminum Drive Shaft)	UJ330C
	Brute Force Greaseable	UJ295		Clamp Kit (Frt. Shaft; Frt.)	UJ331-10
	(For Aluminum Drive Shaft)	UJ330C		U-Joint (Frt. Shaft; Rr.)❷	UJ331
	U-Joint (Rr. Shaft; Rr.)❹	UJ330		Brute Force Greaseable	UJ232
	Brute Force Greaseable	UJ295		Brute Force Non Greaseable	UJ231
	(For Aluminum Drive Shaft)	UJ330C		(For Aluminum Drive Shaft)	UJ331C
	U-Joint (Wheel Joint)❺	UJ374		U-Joint (Rr. Shaft; Frt.)❸	UJ330
	Brute Force Non Greaseable	UJ374BF		Brute Force Greaseable	UJ295
2020-2018 F-250 Super Duty w/ 3 Joint Rear Shaft: [Type 27]				(For Aluminum Drive Shaft)	UJ330C
	U-Joint (Frt. Shaft; Frt.)❶	UJ330		Clamp Kit (Rr. Shaft; Frt.)	UJ331-10
	Brute Force Greaseable	UJ295		U-Joint (Rr. Shaft; Ctr.)❹	UJ330
	(For Aluminum Drive Shaft)	UJ330C		Brute Force Greaseable	UJ295
	U-Joint (Frt. Shaft; Rr.)❷	UJ330		(For Aluminum Drive Shaft)	UJ330C
	Brute Force Greaseable	UJ295		Clamp Kit (Rr. Shaft; Ctr.)	UJ331-10
	(For Aluminum Drive Shaft)	UJ330C		U-Joint (Rr. Shaft; Rr.)❺	UJ330
	U-Joint (Rr. Shaft; Frt.)❸	UJ330		Brute Force Greaseable	UJ295
	Brute Force Greaseable	UJ295		(For Aluminum Drive Shaft)	UJ330C
	(For Aluminum Drive Shaft)	UJ330C		Clamp Kit (Rr. Shaft; Rr.)	UJ331-10
	U-Joint (Rr. Shaft; Ctr.)❹	UJ330		U-Joint (Wheel Joint)❺	UJ374
	Brute Force Greaseable	UJ295		Brute Force Non Greaseable	UJ374BF
	(For Aluminum Drive Shaft)	UJ330C			(Continued)
	U-Joint (Rr. Shaft; Rr.)❺	UJ330			
	Brute Force Greaseable	UJ295			
	(For Aluminum Drive Shaft)	UJ330C			
	U-Joint (Wheel Joint)❺	UJ374			
	Brute Force Non Greaseable	UJ374BF			

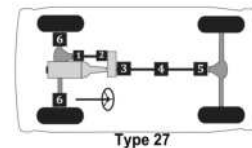
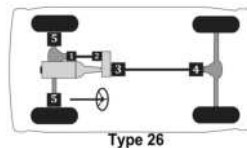
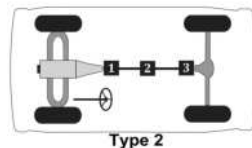

Passenger cars, light & medium trucks

Ford Truck 3/4 ton -- (Cont.)

MFG./YEAR	MODEL & LOCATION	PART NO.	MFG./YEAR	MODEL & LOCATION	PART NO.
Drive Shaft (4 W/D) (Cont.)			Drive Shaft (4 W/D) (Cont.)		
U-Joint (Cont.)			U-Joint (Cont.)		
2017-2011 F-250 Super Duty w/ 2 Joint Shaft & Wide Frt. Axle Design: [Type 26]			2010-2009 F-250 Super Duty w/ 2 Joint Shaft: [Type 28]		
U-Joint (Frt. Shaft; Frt.) [⊙]		UJ330	U-Joint (Frt. Shaft; Frt.) [⊙]		UJ330
Brute Force Greaseable		UJ295	Brute Force Greaseable		UJ295
(For Aluminum Drive Shaft)		UJ330C	(For Aluminum Drive Shaft)		UJ330C
Clamp Kit (Frt. Shaft; Frt.)		UJ331-10	Clamp Kit (Frt. Shaft; Frt.)		UJ331-10
U-Joint (Frt. Shaft; Rr.) [⊙]		UJ331	U-Joint (Rr. Shaft; Frt.) [⊙]		UJ330
Brute Force Greaseable		UJ232	Brute Force Greaseable		UJ295
Brute Force Non Greaseable		UJ231	(For Aluminum Drive Shaft)		UJ330C
(For Aluminum Drive Shaft)		UJ331C	Clamp Kit (Rr. Shaft; Frt.)		UJ331-10
U-Joint (Rr. Shaft; Frt.) [⊙]		UJ330	U-Joint (Rr. Shaft; Rr.) [⊙]		UJ330
Brute Force Greaseable		UJ295	Brute Force Greaseable		UJ295
(For Aluminum Drive Shaft)		UJ330C	(For Aluminum Drive Shaft)		UJ330C
Clamp Kit (Rr. Shaft; Frt.)		UJ331-10	Clamp Kit (Rr. Shaft; Rr.)		UJ331-10
U-Joint (Rr. Shaft; Rr.) [⊙]		UJ330	U-Joint (Wheel Joint) [⊙]		UJ374
Brute Force Greaseable		UJ295	Brute Force Non Greaseable		UJ374BF
(For Aluminum Drive Shaft)		UJ330C	2010-2009 F-250 Super Duty w/ 3 Joint Shaft: [Type 29]		
Clamp Kit (Rr. Shaft; Rr.)		UJ331-10	U-Joint (Frt. Shaft; Frt.) [⊙]		UJ330
U-Joint (Wheel Joint) [⊙]		UJ424	Brute Force Greaseable		UJ295
2017-2011 F-250 Super Duty w/ 3 Joint Shaft & Wide Frt. Axle Design: [Type 27]			(For Aluminum Drive Shaft)		UJ330C
U-Joint (Frt. Shaft; Frt.) [⊙]		UJ330	Clamp Kit (Frt. Shaft; Frt.)		UJ331-10
Brute Force Greaseable		UJ295	U-Joint (Rr. Shaft; Frt.) [⊙]		UJ330
(For Aluminum Drive Shaft)		UJ330C	Brute Force Greaseable		UJ295
Clamp Kit (Frt. Shaft; Frt.)		UJ331-10	(For Aluminum Drive Shaft)		UJ330C
U-Joint (Frt. Shaft; Rr.) [⊙]		UJ331	Clamp Kit (Rr. Shaft; Frt.)		UJ331-10
Brute Force Greaseable		UJ232	U-Joint (Rr. Shaft; Ctr.) [⊙]		UJ330
Brute Force Non Greaseable		UJ231	Brute Force Greaseable		UJ295
(For Aluminum Drive Shaft)		UJ331C	(For Aluminum Drive Shaft)		UJ330C
U-Joint (Rr. Shaft; Frt.) [⊙]		UJ330	Clamp Kit (Rr. Shaft; Ctr.)		UJ331-10
Brute Force Greaseable		UJ295	U-Joint (Rr. Shaft; Rr.) [⊙]		UJ330
(For Aluminum Drive Shaft)		UJ330C	Brute Force Greaseable		UJ295
Clamp Kit (Rr. Shaft; Frt.)		UJ331-10	(For Aluminum Drive Shaft)		UJ330C
U-Joint (Rr. Shaft; Ctr.) [⊙]		UJ330	Clamp Kit (Rr. Shaft; Rr.)		UJ331-10
Brute Force Greaseable		UJ295	U-Joint (Wheel Joint) [⊙]		UJ374
(For Aluminum Drive Shaft)		UJ330C	Brute Force Non Greaseable		UJ374BF
Clamp Kit (Rr. Shaft; Ctr.)		UJ331-10	2008-2005 F-250 Super Duty w/ 2 Joint Shaft: [Type 28]		
U-Joint (Rr. Shaft; Rr.) [⊙]		UJ330	U-Joint (Frt. Shaft; Frt.) [⊙]		UJ330
Brute Force Greaseable		UJ295	Brute Force Greaseable		UJ295
(For Aluminum Drive Shaft)		UJ330C	(For Aluminum Drive Shaft)		UJ330C
Clamp Kit (Rr. Shaft; Rr.)		UJ331-10	Clamp Kit (Frt. Shaft; Frt.)		UJ331-10
U-Joint (Wheel Joint) [⊙]		UJ424	U-Joint (Rr. Shaft; Frt.) [⊙]		UJ330
			Brute Force Greaseable		UJ295
			(For Aluminum Drive Shaft)		UJ330C
			U-Joint (Rr. Shaft; Rr.) [⊙]		UJ330
			Brute Force Greaseable		UJ295
			(For Aluminum Drive Shaft)		UJ330C
			Clamp Kit (Rr. Shaft; Rr.)		UJ331-10
			U-Joint (Wheel Joint) [⊙]		UJ374
			Brute Force Non Greaseable		UJ374BF

(Continued)

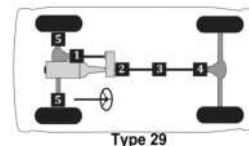
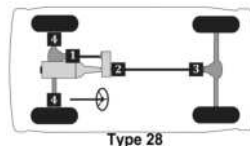
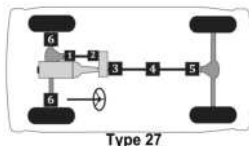
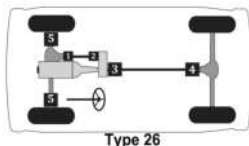

MFG./YEAR	MODEL & LOCATION	PART NO.	MFG./YEAR	MODEL & LOCATION	PART NO.
Drive Shaft (4 W/D) (Cont.)			Drive Shaft (4 W/D) (Cont.)		
U-Joint (Cont.)			U-Joint (Cont.)		
2008-2005 F-250 Super Duty w/ 3 Joint Shaft:			2004-1999 F-250 Super Duty w/ Ext. Cab, Short Bed & 5.4L Eng.: [Type 26]		
[Type 29]			[Type 26]		
	U-Joint (Fr. Shaft; Fr.) ①	UJ331		U-Joint (Fr. Shaft; Fr.) ①	UJ331
	<i>Brute Force Greaseable</i>	UJ232		<i>Brute Force Greaseable</i>	UJ232
	<i>Brute Force Non Greaseable</i>	UJ231		<i>Brute Force Non Greaseable</i>	UJ231
	(For Aluminum Drive Shaft)	UJ331C		(For Aluminum Drive Shaft)	UJ331C
	Clamp Kit (Fr. Shaft; Fr.)	UJ331-10		Clamp Kit (Fr. Shaft; Fr.)	UJ331-10
	U-Joint (Rr. Shaft; Fr.) ②	UJ330		U-Joint (Fr. Shaft; Rr.) ②	[2] UJ331
	<i>Brute Force Greaseable</i>	UJ295		<i>Brute Force Greaseable</i>	UJ232
	(For Aluminum Drive Shaft)	UJ330C		<i>Brute Force Non Greaseable</i>	UJ231
	U-Joint (Rr. Shaft; Ctr.) ③	UJ330		(For Aluminum Drive Shaft)	UJ331C
	<i>Brute Force Greaseable</i>	UJ295		Clamp Kit (Fr. Shaft; Rr.)	UJ331-10
	(For Aluminum Drive Shaft)	UJ330C		U-Joint (Rr. Shaft; Fr.) ④	[2] UJ331
	U-Joint (Rr. Shaft; Rr.) ④	UJ330		<i>Brute Force Greaseable</i>	UJ232
	<i>Brute Force Greaseable</i>	UJ295		<i>Brute Force Non Greaseable</i>	UJ231
	(For Aluminum Drive Shaft)	UJ330C		(For Aluminum Drive Shaft)	UJ331C
	U-Joint (Wheel Joint) ⑤	UJ374		Clamp Kit (Rr. Shaft; Fr.)	UJ331-10
	<i>Brute Force Non Greaseable</i>	UJ374BF		U-Joint (Rr. Shaft; Rr.) ⑤	UJ331
	2004-1999 F-250 Super Duty w/ Reg. Cab & 5.4L Eng.: [Type 26]			<i>Brute Force Greaseable</i>	UJ232
	U-Joint (Fr. Shaft; Fr.) ①	UJ331		<i>Brute Force Non Greaseable</i>	UJ231
	<i>Brute Force Greaseable</i>	UJ232		(For Aluminum Drive Shaft)	UJ331C
	<i>Brute Force Non Greaseable</i>	UJ231		Clamp Kit (Rr. Shaft; Rr.)	UJ331-10
	(For Aluminum Drive Shaft)	UJ331C		U-Joint (Wheel Joint) ⑥	UJ374
	Clamp Kit (Fr. Shaft; Fr.)	UJ331-10		<i>Brute Force Non Greaseable</i>	UJ374BF
	U-Joint (Fr. Shaft; Rr.) ②	[2] UJ331		Centering Ball Kit	UJ617
	<i>Brute Force Greaseable</i>	UJ232		Ball Seat Repair Kit	UJ606
	<i>Brute Force Non Greaseable</i>	UJ231		Flange Yoke	UJ630F
	(For Aluminum Drive Shaft)	UJ331C		H Yoke	UJ650
	Clamp Kit (Fr. Shaft; Rr.)	UJ331-10			(Continued)
	U-Joint (Rr. Shaft; Fr.) ③	[2] UJ331			
	<i>Brute Force Greaseable</i>	UJ232			
	<i>Brute Force Non Greaseable</i>	UJ231			
	(For Aluminum Drive Shaft)	UJ331C			
	Clamp Kit (Rr. Shaft; Fr.)	UJ331-10			
	U-Joint (Rr. Shaft; Rr.) ④	UJ331			
	<i>Brute Force Greaseable</i>	UJ232			
	<i>Brute Force Non Greaseable</i>	UJ231			
	(For Aluminum Drive Shaft)	UJ331C			
	Clamp Kit (Rr. Shaft; Rr.)	UJ331-10			
	U-Joint (Wheel Joint) ⑤	UJ374			
	<i>Brute Force Non Greaseable</i>	UJ374BF			

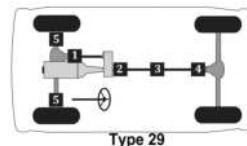
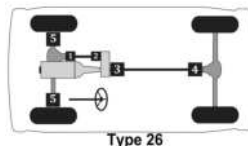

Passenger cars, light & medium trucks

Ford Truck 3/4 ton -- (Cont.)

MFG./YEAR	MODEL & LOCATION	PART NO.	MFG./YEAR	MODEL & LOCATION	PART NO.
Drive Shaft (4 W/D) (Cont.)			Drive Shaft (4 W/D) (Cont.)		
U-Joint (Cont.)			U-Joint (Cont.)		
2004-1999 F-250 Super Duty w/ Ext. Cab, Long Bed & 5.4L Eng.: [Type 27]			2004-1999 F-250 Super Duty w/ Crew Cab & 5.4L Eng.: [Type 27]		
U-Joint (Fr. Shaft; Fr.) ⊙		UJ331	U-Joint (Fr. Shaft; Fr.) ⊙		UJ331
<i>Brute Force Greaseable</i>		UJ232	<i>Brute Force Greaseable</i>		UJ232
<i>Brute Force Non Greaseable</i>		UJ231	<i>Brute Force Non Greaseable</i>		UJ231
(For Aluminum Drive Shaft)		UJ331C	(For Aluminum Drive Shaft)		UJ331C
Clamp Kit (Fr. Shaft; Fr.)		UJ331-10	Clamp Kit (Fr. Shaft; Fr.)		UJ331-10
U-Joint (Fr. Shaft; Rr.) ⊙	[2]	UJ331	U-Joint (Fr. Shaft; Rr.) ⊙	[2]	UJ331
<i>Brute Force Greaseable</i>		UJ232	<i>Brute Force Greaseable</i>		UJ232
<i>Brute Force Non Greaseable</i>		UJ231	<i>Brute Force Non Greaseable</i>		UJ231
(For Aluminum Drive Shaft)		UJ331C	(For Aluminum Drive Shaft)		UJ331C
Clamp Kit (Fr. Shaft; Rr.)		UJ331-10	Clamp Kit (Fr. Shaft; Rr.)		UJ331-10
U-Joint (Rr. Shaft; Fr.) ⊙		UJ331	U-Joint (Rr. Shaft; Fr.) ⊙		UJ331
<i>Brute Force Greaseable</i>		UJ232	<i>Brute Force Greaseable</i>		UJ232
<i>Brute Force Non Greaseable</i>		UJ231	<i>Brute Force Non Greaseable</i>		UJ231
(For Aluminum Drive Shaft)		UJ331C	(For Aluminum Drive Shaft)		UJ331C
Clamp Kit (Rr. Shaft; Fr.)		UJ331-10	Clamp Kit (Rr. Shaft; Fr.)		UJ331-10
U-Joint (Rr. Shaft; Ctr.) ⊙		UJ331	U-Joint (Rr. Shaft; Ctr.) ⊙		UJ331
<i>Brute Force Greaseable</i>		UJ232	<i>Brute Force Greaseable</i>		UJ232
<i>Brute Force Non Greaseable</i>		UJ231	<i>Brute Force Non Greaseable</i>		UJ231
(For Aluminum Drive Shaft)		UJ331C	(For Aluminum Drive Shaft)		UJ331C
Clamp Kit (Rr. Shaft; Ctr.)		UJ331-10	Clamp Kit (Rr. Shaft; Ctr.)		UJ331-10
U-Joint (Rr. Shaft; Rr.) ⊙		UJ331	U-Joint (Rr. Shaft; Rr.) ⊙		UJ331
<i>Brute Force Greaseable</i>		UJ232	<i>Brute Force Greaseable</i>		UJ232
<i>Brute Force Non Greaseable</i>		UJ231	<i>Brute Force Non Greaseable</i>		UJ231
(For Aluminum Drive Shaft)		UJ331C	(For Aluminum Drive Shaft)		UJ331C
Clamp Kit (Rr. Shaft; Rr.)		UJ331-10	Clamp Kit (Rr. Shaft; Rr.)		UJ331-10
U-Joint (Wheel Joint) ⊙		UJ374	U-Joint (Wheel Joint) ⊙		UJ374
<i>Brute Force Non Greaseable</i>		UJ374BF	<i>Brute Force Non Greaseable</i>		UJ374BF
Centering Ball Kit		UJ617	Centering Ball Kit		UJ617
Ball Seat Repair Kit		UJ606	Ball Seat Repair Kit		UJ606
Flange Yoke		UJ630F	Flange Yoke		UJ630F
H Yoke		UJ650	H Yoke		UJ650

(Continued)

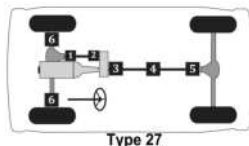

MFG./YEAR	MODEL & LOCATION	PART NO.	MFG./YEAR	MODEL & LOCATION	PART NO.
Drive Shaft (4 W/D) (Cont.)			Drive Shaft (4 W/D) (Cont.)		
U-Joint (Cont.)			U-Joint (Cont.)		
2004-1999 F-250 Super Duty Cab & Chassis w/			2004-1999 F-250 Super Duty w/ Reg. Cab, 6.0L,		
5.4L Eng.: [Type 27]			6.8L & 7.3L Eng.: [Type 26]		
U-Joint (Frnt. Shaft; Frnt.) [Ⓛ]		UJ331	U-Joint (Frnt. Shaft; Frnt.) [Ⓛ]		UJ331
Brute Force Greaseable		UJ232	Brute Force Greaseable		UJ232
Brute Force Non Greaseable		UJ231	Brute Force Non Greaseable		UJ231
(For Aluminum Drive Shaft)		UJ331C	(For Aluminum Drive Shaft)		UJ331C
Clamp Kit (Frnt. Shaft; Frnt.)		UJ331-10	Clamp Kit (Frnt. Shaft; Frnt.)		UJ331-10
U-Joint (Frnt. Shaft; Rr.) [Ⓡ]	[2]	UJ331	U-Joint (Frnt. Shaft; Rr.) [Ⓡ]	[2]	UJ331
Brute Force Greaseable		UJ232	Brute Force Greaseable		UJ232
Brute Force Non Greaseable		UJ231	Brute Force Non Greaseable		UJ231
(For Aluminum Drive Shaft)		UJ331C	(For Aluminum Drive Shaft)		UJ331C
Clamp Kit (Frnt. Shaft; Rr.)		UJ331-10	Clamp Kit (Frnt. Shaft; Rr.)		UJ331-10
U-Joint (Rr. Shaft; Frnt.) [Ⓛ]		UJ331	U-Joint (Rr. Shaft; Frnt.) [Ⓛ]	[2]	UJ331
Brute Force Greaseable		UJ232	Brute Force Greaseable		UJ232
Brute Force Non Greaseable		UJ231	Brute Force Non Greaseable		UJ231
(For Aluminum Drive Shaft)		UJ331C	(For Aluminum Drive Shaft)		UJ331C
Clamp Kit (Rr. Shaft; Frnt.)		UJ331-10	Clamp Kit (Rr. Shaft; Frnt.)		UJ331-10
U-Joint (Rr. Shaft; Ctr.) [Ⓡ]		UJ331	U-Joint (Rr. Shaft; Rr.) [Ⓡ]		UJ330
Brute Force Greaseable		UJ232	Brute Force Greaseable		UJ295
Brute Force Non Greaseable		UJ231	(For Aluminum Drive Shaft)		UJ330C
(For Aluminum Drive Shaft)		UJ331C	U-Joint (Wheel Joint) [Ⓡ]		UJ374
Clamp Kit (Rr. Shaft; Ctr.)		UJ331-10	Brute Force Non Greaseable		UJ374BF
U-Joint (Rr. Shaft; Rr.) [Ⓡ]		UJ331	Centering Ball Kit		UJ617
Brute Force Greaseable		UJ232	Ball Seat Repair Kit		UJ606
Brute Force Non Greaseable		UJ231	Flange Yoke		UJ630F
(For Aluminum Drive Shaft)		UJ331C	H Yoke		UJ650
Clamp Kit (Rr. Shaft; Rr.)		UJ331-10			(Continued)
U-Joint (Wheel Joint) [Ⓡ]		UJ374			
Brute Force Non Greaseable		UJ374BF			
Centering Ball Kit		UJ617			
Ball Seat Repair Kit		UJ606			
Flange Yoke		UJ630F			
H Yoke		UJ650			

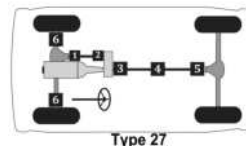
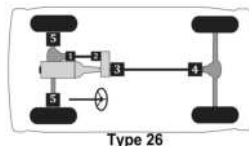

Passenger cars, light & medium trucks

Ford Truck 3/4 ton -- (Cont.)

MFG./YEAR	MODEL & LOCATION	PART NO.	MFG./YEAR	MODEL & LOCATION	PART NO.
-----------	------------------	----------	-----------	------------------	----------

Drive Shaft (4 W/D) (Cont.)

U-Joint (Cont.)

2004-1999 F-250 Super Duty w/ Ext. Cab, Short Bed, 6.0L, 6.8L & 7.3L Eng.s.: [Type 26]

U-Joint (Fr. Shaft; Frt.) ⓐ	UJ331
Brute Force Greaseable	UJ232
Brute Force Non Greaseable	UJ231
(For Aluminum Drive Shaft)	UJ331C
Clamp Kit (Fr. Shaft; Frt.)	UJ331-10
U-Joint (Fr. Shaft; Rr.) ⓑ	[2] UJ331
Brute Force Greaseable	UJ232
Brute Force Non Greaseable	UJ231
(For Aluminum Drive Shaft)	UJ331C
Clamp Kit (Fr. Shaft; Rr.)	UJ331-10
U-Joint (Rr. Shaft; Frt.) ⓐ	[2] UJ331
Brute Force Greaseable	UJ232
Brute Force Non Greaseable	UJ231
(For Aluminum Drive Shaft)	UJ331C
Clamp Kit (Rr. Shaft; Frt.)	UJ331-10
U-Joint (Rr. Shaft; Rr.) ⓑ	UJ330
Brute Force Greaseable	UJ295
(For Aluminum Drive Shaft)	UJ330C
U-Joint (Rr. Shaft; Ctr.) ⓑ	UJ330
Brute Force Greaseable	UJ295
(For Aluminum Drive Shaft)	UJ330C
U-Joint (Rr. Shaft; Rr.) ⓐ	UJ330
Brute Force Greaseable	UJ295
(For Aluminum Drive Shaft)	UJ330C
U-Joint (Wheel Joint) ⓐ	UJ374
Brute Force Non Greaseable	UJ374BF
Centering Ball Kit	UJ617
Ball Seat Repair Kit	UJ606
Flange Yoke	UJ630F
H Yoke	UJ650

Drive Shaft (4 W/D) (Cont.)

U-Joint (Cont.)

2004-1999 F-250 Super Duty w/ Ext. Cab, Long Bed, 6.0L, 6.8L & 7.3L Eng.s.: [Type 27]

U-Joint (Fr. Shaft; Frt.) ⓐ	UJ331
Brute Force Greaseable	UJ232
Brute Force Non Greaseable	UJ231
(For Aluminum Drive Shaft)	UJ331C
Clamp Kit (Fr. Shaft; Frt.)	UJ331-10
U-Joint (Fr. Shaft; Rr.) ⓑ	[2] UJ331
Brute Force Greaseable	UJ232
Brute Force Non Greaseable	UJ231
(For Aluminum Drive Shaft)	UJ331C
Clamp Kit (Fr. Shaft; Rr.)	UJ331-10
U-Joint (Rr. Shaft; Frt.) ⓐ	UJ330
Brute Force Greaseable	UJ295
(For Aluminum Drive Shaft)	UJ330C
U-Joint (Rr. Shaft; Ctr.) ⓑ	UJ330
Brute Force Greaseable	UJ295
(For Aluminum Drive Shaft)	UJ330C
U-Joint (Rr. Shaft; Rr.) ⓐ	UJ330
Brute Force Greaseable	UJ295
(For Aluminum Drive Shaft)	UJ330C
U-Joint (Wheel Joint) ⓐ	UJ374
Brute Force Non Greaseable	UJ374BF
Centering Ball Kit	UJ617
Ball Seat Repair Kit	UJ606
Flange Yoke	UJ630F
H Yoke	UJ650

(Continued)

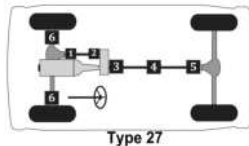
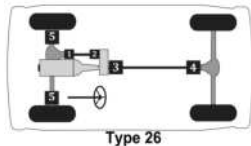

MFG./YEAR	MODEL & LOCATION	PART NO.	MFG./YEAR	MODEL & LOCATION	PART NO.
Drive Shaft (4 W/D) (Cont.)			Drive Shaft (4 W/D) (Cont.)		
U-Joint (Cont.)			U-Joint (Cont.)		
2004-1999 F-250 Super Duty w/ Crew Cab, 6.0L, 6.8L & 7.3L Engs.: [Type 27]			2004-1999 F-250 Super Duty Cab & Chassis w/ 6.0L, 6.8L & 7.3L Engs.: [Type 27]		
	U-Joint (Frnt. Shaft; Frnt.) ^①	UJ331		U-Joint (Frnt. Shaft; Frnt.) ^①	UJ331
	Brute Force Greaseable	UJ232		Brute Force Greaseable	UJ232
	Brute Force Non Greaseable	UJ231		Brute Force Non Greaseable	UJ231
	(For Aluminum Drive Shaft)	UJ331C		(For Aluminum Drive Shaft)	UJ331C
	Clamp Kit (Frnt. Shaft; Frnt.)	UJ331-10		Clamp Kit (Frnt. Shaft; Frnt.)	UJ331-10
	U-Joint (Frnt. Shaft; Rr.) ^②	[2] UJ331		U-Joint (Frnt. Shaft; Rr.) ^②	[2] UJ331
	Brute Force Greaseable	UJ232		Brute Force Greaseable	UJ232
	Brute Force Non Greaseable	UJ231		Brute Force Non Greaseable	UJ231
	(For Aluminum Drive Shaft)	UJ331C		(For Aluminum Drive Shaft)	UJ331C
	Clamp Kit (Frnt. Shaft; Rr.)	UJ331-10		Clamp Kit (Frnt. Shaft; Rr.)	UJ331-10
	U-Joint (Rr. Shaft; Frnt.) ^③	UJ330		U-Joint (Rr. Shaft; Frnt.) ^③	UJ330
	Brute Force Greaseable	UJ295		Brute Force Greaseable	UJ295
	(For Aluminum Drive Shaft)	UJ330C		(For Aluminum Drive Shaft)	UJ330C
	U-Joint (Rr. Shaft; Ctr.) ^④	UJ330		U-Joint (Rr. Shaft; Ctr.) ^④	UJ330
	Brute Force Greaseable	UJ295		Brute Force Greaseable	UJ295
	(For Aluminum Drive Shaft)	UJ330C		(For Aluminum Drive Shaft)	UJ330C
	U-Joint (Rr. Shaft; Rr.) ^⑤	UJ330		U-Joint (Rr. Shaft; Rr.) ^⑤	UJ330
	Brute Force Greaseable	UJ295		Brute Force Greaseable	UJ295
	(For Aluminum Drive Shaft)	UJ330C		(For Aluminum Drive Shaft)	UJ330C
	U-Joint (Wheel Joint) ^⑥	UJ374		U-Joint (Wheel Joint) ^⑥	UJ374
	Brute Force Non Greaseable	UJ374BF		Brute Force Non Greaseable	UJ374BF
	Centering Ball Kit	UJ617		Centering Ball Kit	UJ617
	Ball Seat Repair Kit	UJ606		Ball Seat Repair Kit	UJ606
	Flange Yoke	UJ630F		Flange Yoke	UJ630F
	H Yoke	UJ650		H Yoke	UJ650
			1999-1997 F-250 w/ 4.6L & 5.4L Engs.: [Type 13]		
	U-Joint (Frnt. Shaft; Frnt.) ^①	UJ354		U-Joint (Frnt. Shaft; Frnt.) ^①	UJ354
	Brute Force Greaseable	UJ270		Brute Force Greaseable	UJ270
	Brute Force Non Greaseable	UJ254		Brute Force Non Greaseable	UJ254
	(For Aluminum Drive Shaft)	UJ354C		(For Aluminum Drive Shaft)	UJ354C
	U-Joint (Frnt. Shaft; Rr.) ^②	UJ354		U-Joint (Frnt. Shaft; Rr.) ^②	UJ354
	Brute Force Greaseable	UJ270		Brute Force Greaseable	UJ270
	Brute Force Non Greaseable	UJ254		Brute Force Non Greaseable	UJ254
	(For Aluminum Drive Shaft)	UJ354C		(For Aluminum Drive Shaft)	UJ354C
	U-Joint (Rr. Shaft; Frnt.) ^③	UJ331		U-Joint (Rr. Shaft; Frnt.) ^③	UJ331
	Brute Force Greaseable	UJ232		Brute Force Greaseable	UJ232
	Brute Force Non Greaseable	UJ231		Brute Force Non Greaseable	UJ231
	(For Aluminum Drive Shaft)	UJ331C		(For Aluminum Drive Shaft)	UJ331C
	U-Joint (Rr. Shaft; Rr.) ^④	UJ331		U-Joint (Rr. Shaft; Rr.) ^④	UJ331
	Brute Force Greaseable	UJ232		Brute Force Greaseable	UJ232
	Brute Force Non Greaseable	UJ231		Brute Force Non Greaseable	UJ231
	(For Aluminum Drive Shaft)	UJ331C		(For Aluminum Drive Shaft)	UJ331C

(Continued)

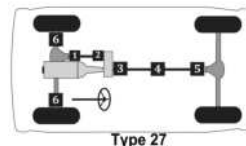
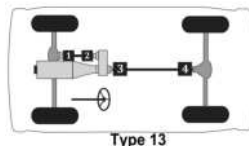

Passenger cars, light & medium trucks

Ford Truck 3/4 ton -- (Cont.)

MFG./YEAR	MODEL & LOCATION	PART NO.	MFG./YEAR	MODEL & LOCATION	PART NO.
Drive Shaft (4 W/D) (Cont.)			Drive Shaft (4 W/D) (Cont.)		
U-Joint (Cont.)			U-Joint (Cont.)		
1997	F-250 w/ 5.8L Eng., 2 Joint Rear Shaft & HD Front Axle: [Type 36]		1997	F-250 w/ 5.8L Eng., 3 Joint Rear Shaft & HD Front Axle: [Type 37]	
	U-Joint (Fr. Shaft; Fr.) [⊙]	UJ434		U-Joint (Fr. Shaft; Fr.) [⊙]	UJ434
	Brute Force Greaseable	UJ265		Brute Force Greaseable	UJ265
	Brute Force Non Greaseable	UJ264		Brute Force Non Greaseable	UJ264
	U-Bolt Kit (Fr. Shaft; Fr.)	UJ534-10		U-Bolt Kit (Fr. Shaft; Fr.)	UJ534-10
	U-Joint (Fr. Shaft; Rr.) [⊙]	UJ434		U-Joint (Fr. Shaft; Rr.) [⊙]	UJ434
	Brute Force Greaseable	UJ265		Brute Force Greaseable	UJ265
	Brute Force Non Greaseable	UJ264		Brute Force Non Greaseable	UJ264
	U-Bolt Kit (Fr. Shaft; Rr.)	UJ534-10		U-Bolt Kit (Fr. Shaft; Rr.)	UJ534-10
	U-Joint (Rr. Shaft; Fr.) [⊙]	UJ354		U-Joint (Rr. Shaft; Fr.) [⊙]	UJ354
	Brute Force Greaseable	UJ270		Brute Force Greaseable	UJ270
	Brute Force Non Greaseable	UJ254		Brute Force Non Greaseable	UJ254
	(For Aluminum Drive Shaft)	UJ354C		(For Aluminum Drive Shaft)	UJ354C
	U-Joint (Rr. Shaft; Rr.) [⊙]	UJ434		U-Joint (Rr. Shaft; Rr.) [⊙]	UJ434
	Brute Force Greaseable	UJ265		Brute Force Greaseable	UJ270
	Brute Force Non Greaseable	UJ264		Brute Force Non Greaseable	UJ254
	U-Bolt Kit (Rr. Shaft; Rr.)	UJ534-10		U-Bolt Kit (Rr. Shaft; Rr.)	UJ354C
	U-Joint (Front Axle Left Outer) [⊙]	<input type="checkbox"/> UJ231		U-Joint (Rr. Shaft; Rr.) [⊙]	UJ434
	(For Aluminum Drive Shaft)	UJ231C		Brute Force Greaseable	UJ265
	U-Joint (Front Axle Right Inner) [⊙]	<input type="checkbox"/> UJ231		Brute Force Non Greaseable	UJ264
	(For Aluminum Drive Shaft)	UJ231C		U-Bolt Kit (Rr. Shaft; Rr.)	UJ534-10
	U-Joint (Front Axle Right Outer) [⊙]	<input type="checkbox"/> UJ231		U-Joint (Front Axle Left Outer) [⊙]	<input type="checkbox"/> UJ231
	(For Aluminum Drive Shaft)	UJ231C		(For Aluminum Drive Shaft)	UJ231C
				U-Joint (Front Axle Right Inner) [⊙]	<input type="checkbox"/> UJ231
				(For Aluminum Drive Shaft)	UJ231C
				U-Joint (Front Axle Right Outer) [⊙]	<input type="checkbox"/> UJ231
				(For Aluminum Drive Shaft)	UJ231C

(Continued)

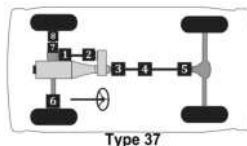
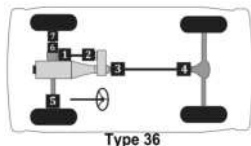

MFG./YEAR	MODEL & LOCATION	PART NO.	MFG./YEAR	MODEL & LOCATION	PART NO.
Drive Shaft (4 W/D) (Cont.)			Drive Shaft (4 W/D) (Cont.)		
U-Joint (Cont.)			U-Joint (Cont.)		
1997	F-250 w/ 7.3L & 7.5L Engs., 2 Joint Rear Shaft & HD Front Axle: [Type 36]		1997	F-250 w/ 7.3L & 7.5L Engs., 3 Joint Rear Shaft & HD Front Axle: [Type 37]	
	U-Joint (Frnt. Shaft; Frt.) ①	UJ434		U-Joint (Frnt. Shaft; Frt.) ①	UJ434
	<i>Brute Force Greaseable</i>	UJ265		<i>Brute Force Greaseable</i>	UJ265
	<i>Brute Force Non Greaseable</i>	UJ264		<i>Brute Force Non Greaseable</i>	UJ264
	U-Bolt Kit (Frnt. Shaft; Frt.)	UJ534-10		U-Bolt Kit (Frnt. Shaft; Frt.)	UJ534-10
	U-Joint (Frnt. Shaft; Rr.) ②	UJ434		U-Joint (Frnt. Shaft; Rr.) ②	UJ434
	<i>Brute Force Greaseable</i>	UJ265		<i>Brute Force Greaseable</i>	UJ265
	<i>Brute Force Non Greaseable</i>	UJ264		<i>Brute Force Non Greaseable</i>	UJ264
	U-Bolt Kit (Frnt. Shaft; Rr.)	UJ534-10		U-Bolt Kit (Frnt. Shaft; Rr.)	UJ534-10
	U-Joint (Rr. Shaft; Frt.) ③	UJ331		U-Joint (Rr. Shaft; Frt.) ③	UJ331
	<i>Brute Force Greaseable</i>	UJ232		<i>Brute Force Greaseable</i>	UJ232
	<i>Brute Force Non Greaseable</i>	UJ231		<i>Brute Force Non Greaseable</i>	UJ231
	(For Aluminum Drive Shaft)	UJ331C		(For Aluminum Drive Shaft)	UJ331C
	Clamp Kit (Rr. Shaft; Frt.)	UJ331-10		Clamp Kit (Rr. Shaft; Frt.)	UJ331-10
	U-Joint (Rr. Shaft; Rr.) ④	UJ331		U-Joint (Rr. Shaft; Rr.) ④	UJ331
	<i>Brute Force Greaseable</i>	UJ232		<i>Brute Force Greaseable</i>	UJ232
	<i>Brute Force Non Greaseable</i>	UJ231		<i>Brute Force Non Greaseable</i>	UJ231
	(For Aluminum Drive Shaft)	UJ331C		(For Aluminum Drive Shaft)	UJ331C
	Clamp Kit (Rr. Shaft; Rr.)	UJ331-10		Clamp Kit (Rr. Shaft; Rr.)	UJ331-10
	U-Joint (Front Axle Left Outer) ⑤	<input type="checkbox"/> UJ231		U-Joint (Rr. Shaft; Rr.) ⑤	UJ331
	(For Aluminum Drive Shaft)	UJ231C		<i>Brute Force Greaseable</i>	UJ232
	U-Joint (Front Axle Right Inner) ⑥	<input type="checkbox"/> UJ231		<i>Brute Force Non Greaseable</i>	UJ231
	(For Aluminum Drive Shaft)	UJ231C		(For Aluminum Drive Shaft)	UJ331C
	U-Joint (Front Axle Right Outer) ⑦	<input type="checkbox"/> UJ231		Clamp Kit (Rr. Shaft; Rr.)	UJ331-10
	(For Aluminum Drive Shaft)	UJ231C		U-Joint (Front Axle Left Outer) ⑧	<input type="checkbox"/> UJ231
				(For Aluminum Drive Shaft)	UJ231C
				U-Joint (Front Axle Right Inner) ⑨	<input type="checkbox"/> UJ231
				(For Aluminum Drive Shaft)	UJ231C
				U-Joint (Front Axle Right Outer) ⑩	<input type="checkbox"/> UJ231
				(For Aluminum Drive Shaft)	UJ231C

(Continued)

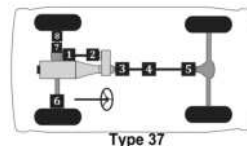
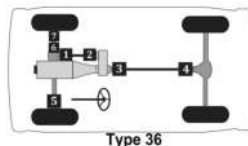

Passenger cars, light & medium trucks

Ford Truck 3/4 ton -- (Cont.)

MFG./YEAR	MODEL & LOCATION	PART NO.	MFG./YEAR	MODEL & LOCATION	PART NO.
Drive Shaft (4 W/D) (Cont.)			Drive Shaft (4 W/D) (Cont.)		
U-Joint (Cont.)			U-Joint (Cont.)		
1997	F-250 w/ 5.8L Eng., 2 Joint Rear Shaft & Std. Front Axle: [Type 36]		1997	F-250 w/ 5.8L Eng., 3 Joint Rear Shaft & Std. Front Axle: [Type 37]	
	U-Joint (Fr. Shaft; Fr.) [ⓐ]	UJ434		U-Joint (Fr. Shaft; Fr.) [ⓐ]	UJ434
	Brute Force Greaseable	UJ265		Brute Force Greaseable	UJ265
	Brute Force Non Greaseable	UJ264		Brute Force Non Greaseable	UJ264
	U-Bolt Kit (Fr. Shaft; Fr.)	UJ534-10		U-Bolt Kit (Fr. Shaft; Fr.)	UJ534-10
	U-Joint (Fr. Shaft; Rr.) [ⓐ]	UJ434		U-Joint (Fr. Shaft; Rr.) [ⓐ]	UJ434
	Brute Force Greaseable	UJ265		Brute Force Greaseable	UJ265
	Brute Force Non Greaseable	UJ264		Brute Force Non Greaseable	UJ264
	U-Bolt Kit (Fr. Shaft; Rr.)	UJ534-10		U-Bolt Kit (Fr. Shaft; Rr.)	UJ534-10
	U-Joint (Rr. Shaft; Fr.) [ⓐ]	UJ354		U-Joint (Rr. Shaft; Fr.) [ⓐ]	UJ354
	Brute Force Greaseable	UJ270		Brute Force Greaseable	UJ270
	Brute Force Non Greaseable	UJ254		Brute Force Non Greaseable	UJ254
	(For Aluminum Drive Shaft)	UJ354C		(For Aluminum Drive Shaft)	UJ354C
	U-Joint (Rr. Shaft; Rr.) [ⓐ]	UJ434		U-Joint (Rr. Shaft; Rr.) [ⓐ]	UJ434
	Brute Force Greaseable	UJ265		Brute Force Greaseable	UJ270
	Brute Force Non Greaseable	UJ264		Brute Force Non Greaseable	UJ254
	U-Bolt Kit (Rr. Shaft; Rr.)	UJ534-10		(For Aluminum Drive Shaft)	UJ354C
	U-Joint (Front Axle Left Outer) [ⓐ]	◇ UJ371		U-Joint (Rr. Shaft; Ctr.) [ⓐ]	UJ354
	Brute Force Greaseable	UJ377		Brute Force Greaseable	UJ270
	Brute Force Non Greaseable	UJ371		Brute Force Non Greaseable	UJ254
	U-Joint (Front Axle Right Inner) [ⓐ]	◇ UJ371		(For Aluminum Drive Shaft)	UJ354C
	Brute Force Greaseable	UJ377		U-Joint (Rr. Shaft; Rr.) [ⓐ]	UJ434
	Brute Force Non Greaseable	UJ371		Brute Force Greaseable	UJ265
	U-Joint (Front Axle Right Outer) [ⓐ]	◇ UJ371		Brute Force Non Greaseable	UJ264
	Brute Force Greaseable	UJ377		U-Bolt Kit (Rr. Shaft; Rr.)	UJ534-10
	Brute Force Non Greaseable	UJ371		U-Joint (Front Axle Left Outer) [ⓐ]	◇ UJ371
				Brute Force Greaseable	UJ377
				Brute Force Non Greaseable	UJ371
				U-Joint (Front Axle Right Inner) [ⓐ]	◇ UJ371
				Brute Force Greaseable	UJ377
				Brute Force Non Greaseable	UJ371
				U-Joint (Front Axle Right Outer) [ⓐ]	◇ UJ371
				Brute Force Greaseable	UJ377
				Brute Force Non Greaseable	UJ371

(Continued)

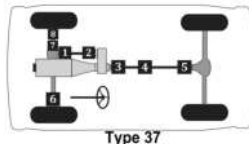
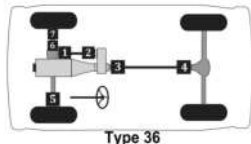

MFG./YEAR	MODEL & LOCATION	PART NO.	MFG./YEAR	MODEL & LOCATION	PART NO.
Drive Shaft (4 W/D) (Cont.)			Drive Shaft (4 W/D) (Cont.)		
U-Joint (Cont.)			U-Joint (Cont.)		
1997	F-250 w/ 7.3L & 7.5L Engs., 2 Joint Rear Shaft & Std. Front Axle: [Type 36]		1997	F-250 w/ 7.3L & 7.5L Engs., 3 Joint Rear Shaft & Std. Front Axle: [Type 37]	
	U-Joint (Frnt. Shaft; Frt.) ①	UJ434		U-Joint (Frnt. Shaft; Frt.) ①	UJ434
	<i>Brute Force Greaseable</i>	UJ265		<i>Brute Force Greaseable</i>	UJ265
	<i>Brute Force Non Greaseable</i>	UJ264		<i>Brute Force Non Greaseable</i>	UJ264
	U-Bolt Kit (Frnt. Shaft; Frt.)	UJ534-10		U-Bolt Kit (Frnt. Shaft; Frt.)	UJ534-10
	U-Joint (Frnt. Shaft; Rr.) ②	UJ434		U-Joint (Frnt. Shaft; Rr.) ②	UJ434
	<i>Brute Force Greaseable</i>	UJ265		<i>Brute Force Greaseable</i>	UJ265
	<i>Brute Force Non Greaseable</i>	UJ264		<i>Brute Force Non Greaseable</i>	UJ264
	U-Bolt Kit (Frnt. Shaft; Rr.)	UJ534-10		U-Bolt Kit (Frnt. Shaft; Rr.)	UJ534-10
	U-Joint (Rr. Shaft; Frt.) ③	UJ331		U-Joint (Rr. Shaft; Frt.) ③	UJ331
	<i>Brute Force Greaseable</i>	UJ232		<i>Brute Force Greaseable</i>	UJ232
	<i>Brute Force Non Greaseable</i>	UJ231		<i>Brute Force Non Greaseable</i>	UJ231
	(For Aluminum Drive Shaft)	UJ331C		(For Aluminum Drive Shaft)	UJ331C
	Clamp Kit (Rr. Shaft; Frt.)	UJ331-10		Clamp Kit (Rr. Shaft; Frt.)	UJ331-10
	U-Joint (Rr. Shaft; Rr.) ④	UJ331		U-Joint (Rr. Shaft; Ctr.) ④	UJ331
	<i>Brute Force Greaseable</i>	UJ232		<i>Brute Force Greaseable</i>	UJ232
	<i>Brute Force Non Greaseable</i>	UJ231		<i>Brute Force Non Greaseable</i>	UJ231
	(For Aluminum Drive Shaft)	UJ331C		(For Aluminum Drive Shaft)	UJ331C
	Clamp Kit (Rr. Shaft; Rr.)	UJ331-10		Clamp Kit (Rr. Shaft; Ctr.)	UJ331-10
	U-Joint (Front Axle Left Outer) ⑤	◇ UJ371		U-Joint (Rr. Shaft; Rr.) ⑤	UJ331
	<i>Brute Force Greaseable</i>	UJ377		<i>Brute Force Greaseable</i>	UJ232
	<i>Brute Force Non Greaseable</i>	UJ371		<i>Brute Force Non Greaseable</i>	UJ231
	U-Joint (Front Axle Right Inner) ⑥	◇ UJ371		(For Aluminum Drive Shaft)	UJ331C
	<i>Brute Force Greaseable</i>	UJ377		Clamp Kit (Rr. Shaft; Rr.)	UJ331-10
	<i>Brute Force Non Greaseable</i>	UJ371		U-Joint (Front Axle Left Outer) ⑥	◇ UJ371
	U-Joint (Front Axle Right Outer) ⑦	◇ UJ371		<i>Brute Force Greaseable</i>	UJ377
	<i>Brute Force Greaseable</i>	UJ377		<i>Brute Force Non Greaseable</i>	UJ371
	<i>Brute Force Non Greaseable</i>	UJ371		U-Joint (Front Axle Right Inner) ⑦	◇ UJ371
				<i>Brute Force Greaseable</i>	UJ377
				<i>Brute Force Non Greaseable</i>	UJ371
				U-Joint (Front Axle Right Outer) ⑧	◇ UJ371
				<i>Brute Force Greaseable</i>	UJ377
				<i>Brute Force Non Greaseable</i>	UJ371

(Continued)

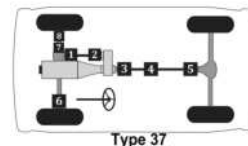
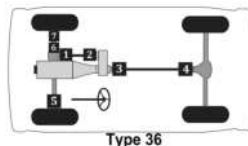

Passenger cars, light & medium trucks

Ford Truck 3/4 ton -- (Cont.)

MFG./YEAR	MODEL & LOCATION	PART NO.	MFG./YEAR	MODEL & LOCATION	PART NO.
-----------	------------------	----------	-----------	------------------	----------

Drive Shaft (4 W/D) (Cont.)

U-Joint (Cont.)

1996-1990 F250 Reg. Cab w/ 7.3L & 7.5L Engs.,
Auto. Trans. & Inner Lock Ring Wheel
Joints: [Type 26]

U-Joint (Fr. Shaft; Frt.) [ⓐ]	UJ434
Brute Force Greaseable	UJ265
Brute Force Non Greaseable	UJ264
U-Bolt Kit (Fr. Shaft; Frt.)	UJ534-10
U-Joint (Fr. Shaft; Rr.) [ⓑ]	UJ434
Brute Force Greaseable	UJ265
Brute Force Non Greaseable	UJ264
U-Bolt Kit (Fr. Shaft; Rr.)	UJ534-10
U-Joint (Rr. Shaft; Frt.) [ⓐ]	UJ434
Brute Force Greaseable	UJ265
Brute Force Non Greaseable	UJ264
U-Bolt Kit (Rr. Shaft; Frt.)	UJ534-10
U-Joint (Rr. Shaft; Rr.) [ⓑ]	UJ434
Brute Force Greaseable	UJ265
Brute Force Non Greaseable	UJ264
U-Bolt Kit (Rr. Shaft; Rr.)	UJ534-10
U-Joint (Wheel Joint) [ⓐ]	[3] UJ371
Brute Force Greaseable	UJ377
Brute Force Non Greaseable	UJ371

1996-1990 F250 Reg. Cab w/ 7.3L & 7.5L Engs.,
Auto. Trans. & Outer Lock Ring Wheel
Joints: [Type 26]

U-Joint (Fr. Shaft; Frt.) [ⓐ]	UJ434
Brute Force Greaseable	UJ265
Brute Force Non Greaseable	UJ264
U-Bolt Kit (Fr. Shaft; Frt.)	UJ534-10
U-Joint (Fr. Shaft; Rr.) [ⓑ]	UJ434
Brute Force Greaseable	UJ265
Brute Force Non Greaseable	UJ264
U-Bolt Kit (Fr. Shaft; Rr.)	UJ534-10
U-Joint (Rr. Shaft; Frt.) [ⓐ]	UJ434
Brute Force Greaseable	UJ265
Brute Force Non Greaseable	UJ264
U-Bolt Kit (Rr. Shaft; Frt.)	UJ534-10
U-Joint (Rr. Shaft; Rr.) [ⓑ]	UJ434
Brute Force Greaseable	UJ265
Brute Force Non Greaseable	UJ264
U-Bolt Kit (Rr. Shaft; Rr.)	UJ534-10
U-Joint (Wheel Joint) [ⓐ]	[3] UJ231
(For Aluminum Drive Shaft)	UJ231C

Drive Shaft (4 W/D) (Cont.)

U-Joint (Cont.)

1996-1990 F250 Crew Cab w/ 7.3L & 7.5L Engs.,
Auto. Trans. & Inner Lock Ring Wheel
Joints: [Type 26]

U-Joint (Fr. Shaft; Frt.) [ⓐ]	UJ434
Brute Force Greaseable	UJ265
Brute Force Non Greaseable	UJ264
U-Bolt Kit (Fr. Shaft; Frt.)	UJ534-10
U-Joint (Fr. Shaft; Rr.) [ⓑ]	UJ434
Brute Force Greaseable	UJ265
Brute Force Non Greaseable	UJ264
U-Bolt Kit (Fr. Shaft; Rr.)	UJ534-10
U-Joint (Rr. Shaft; Frt.) [ⓐ]	UJ434
Brute Force Greaseable	UJ265
Brute Force Non Greaseable	UJ264
U-Bolt Kit (Rr. Shaft; Frt.)	UJ534-10
U-Joint (Rr. Shaft; Rr.) [ⓑ]	UJ434
Brute Force Greaseable	UJ265
Brute Force Non Greaseable	UJ264
U-Bolt Kit (Rr. Shaft; Rr.)	UJ534-10
U-Joint (Wheel Joint) [ⓐ]	[3] UJ371
Brute Force Greaseable	UJ377
Brute Force Non Greaseable	UJ371

1996-1990 F250 Reg. Cab w/ 7.3L & 7.5L Engs.,
Man. Trans. & Outer Lock Ring Wheel
Joints: [Type 26]

U-Joint (Fr. Shaft; Frt.) [ⓐ]	UJ434
Brute Force Greaseable	UJ265
Brute Force Non Greaseable	UJ264
U-Bolt Kit (Fr. Shaft; Frt.)	UJ534-10
U-Joint (Fr. Shaft; Rr.) [ⓑ]	UJ434
Brute Force Greaseable	UJ265
Brute Force Non Greaseable	UJ264
U-Bolt Kit (Fr. Shaft; Rr.)	UJ534-10
U-Joint (Rr. Shaft; Frt.) [ⓐ]	UJ331
Brute Force Greaseable	UJ232
Brute Force Non Greaseable	UJ231
(For Aluminum Drive Shaft)	UJ331C
U-Bolt Kit (Rr. Shaft; Frt.)	UJ331-10
U-Joint (Rr. Shaft; Rr.) [ⓑ]	UJ331
Brute Force Greaseable	UJ232
Brute Force Non Greaseable	UJ231
(For Aluminum Drive Shaft)	UJ331C
U-Bolt Kit (Rr. Shaft; Rr.)	UJ331-10
U-Joint (Wheel Joint) [ⓐ]	[3] UJ231
(For Aluminum Drive Shaft)	UJ231C

(Continued)

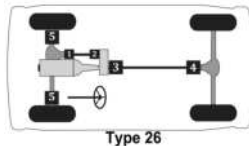

MFG./YEAR	MODEL & LOCATION	PART NO.	MFG./YEAR	MODEL & LOCATION	PART NO.
Drive Shaft (4 W/D) (Cont.)			Drive Shaft (4 W/D) (Cont.)		
U-Joint (Cont.)			U-Joint (Cont.)		
1996-1990 F250 Crew Cab w/ 7.3L & 7.5L Engs., Auto. Trans. & Outer Lock Ring Wheel Joints: [Type 26]			1996-1990 F250 Crew Cab w/ 7.3L & 7.5L Engs., Man. Trans. & Outer Lock Ring Wheel Joints: [Type 26]		
U-Joint (Frt. Shaft; Frt.)Ⓢ		UJ434	U-Joint (Frt. Shaft; Frt.)Ⓢ		UJ434
Brute Force Greaseable		UJ265	Brute Force Greaseable		UJ265
Brute Force Non Greaseable		UJ264	Brute Force Non Greaseable		UJ264
U-Bolt Kit (Frt. Shaft; Frt.)		UJ534-10	U-Bolt Kit (Frt. Shaft; Frt.)		UJ534-10
U-Joint (Frt. Shaft; Rr.)Ⓢ		UJ434	U-Joint (Frt. Shaft; Rr.)Ⓢ		UJ434
Brute Force Greaseable		UJ265	Brute Force Greaseable		UJ265
Brute Force Non Greaseable		UJ264	Brute Force Non Greaseable		UJ264
U-Bolt Kit (Frt. Shaft; Rr.)		UJ534-10	U-Bolt Kit (Frt. Shaft; Rr.)		UJ534-10
U-Joint (Rr. Shaft; Frt.)Ⓢ		UJ434	U-Joint (Rr. Shaft; Frt.)Ⓢ		UJ331
Brute Force Greaseable		UJ265	Brute Force Greaseable		UJ232
Brute Force Non Greaseable		UJ264	Brute Force Non Greaseable		UJ231
U-Bolt Kit (Rr. Shaft; Frt.)		UJ534-10	(For Aluminum Drive Shaft)		UJ331C
U-Joint (Rr. Shaft; Rr.)Ⓢ		UJ434	U-Bolt Kit (Rr. Shaft; Frt.)		UJ331-10
Brute Force Greaseable		UJ265	U-Joint (Rr. Shaft; Rr.)Ⓢ		UJ331
Brute Force Non Greaseable		UJ264	Brute Force Greaseable		UJ232
U-Bolt Kit (Rr. Shaft; Rr.)		UJ534-10	Brute Force Non Greaseable		UJ231
U-Joint (Wheel Joint)Ⓢ	[3]	UJ231	(For Aluminum Drive Shaft)		UJ331C
(For Aluminum Drive Shaft)		UJ231C	U-Bolt Kit (Rr. Shaft; Rr.)		UJ331-10
1996-1990 F250 Reg. Cab w/ 7.3L & 7.5L Engs., Man. Trans. & Inner Lock Ring Wheel Joints: [Type 26]			U-Joint (Wheel Joint)Ⓢ	[3]	UJ231
U-Joint (Frt. Shaft; Frt.)Ⓢ		UJ434	(For Aluminum Drive Shaft)		UJ231C
Brute Force Greaseable		UJ265	1996-1990 F250 Crew Cab w/ 7.3L & 7.5L Engs., Man. Trans. & Inner Lock Ring Wheel Joints: [Type 26]		
Brute Force Non Greaseable		UJ264	U-Joint (Frt. Shaft; Frt.)Ⓢ		UJ434
U-Bolt Kit (Frt. Shaft; Frt.)		UJ534-10	Brute Force Greaseable		UJ265
U-Joint (Frt. Shaft; Rr.)Ⓢ		UJ434	Brute Force Non Greaseable		UJ264
Brute Force Greaseable		UJ265	U-Bolt Kit (Frt. Shaft; Frt.)		UJ534-10
Brute Force Non Greaseable		UJ264	U-Joint (Frt. Shaft; Rr.)Ⓢ		UJ434
U-Bolt Kit (Frt. Shaft; Rr.)		UJ534-10	Brute Force Greaseable		UJ265
U-Joint (Rr. Shaft; Frt.)Ⓢ		UJ331	Brute Force Non Greaseable		UJ264
Brute Force Greaseable		UJ232	U-Bolt Kit (Frt. Shaft; Rr.)		UJ534-10
Brute Force Non Greaseable		UJ231	U-Joint (Rr. Shaft; Frt.)Ⓢ		UJ331
(For Aluminum Drive Shaft)		UJ331C	Brute Force Greaseable		UJ232
U-Bolt Kit (Rr. Shaft; Frt.)		UJ331-10	Brute Force Non Greaseable		UJ231
U-Joint (Rr. Shaft; Rr.)Ⓢ		UJ331	(For Aluminum Drive Shaft)		UJ331C
Brute Force Greaseable		UJ232	U-Bolt Kit (Rr. Shaft; Frt.)		UJ331-10
Brute Force Non Greaseable		UJ231	U-Joint (Rr. Shaft; Rr.)Ⓢ		UJ331
(For Aluminum Drive Shaft)		UJ331C	Brute Force Greaseable		UJ232
U-Bolt Kit (Rr. Shaft; Rr.)		UJ331-10	Brute Force Non Greaseable		UJ231
U-Joint (Wheel Joint)Ⓢ	[3]	UJ371	(For Aluminum Drive Shaft)		UJ331C
Brute Force Greaseable		UJ377	U-Bolt Kit (Rr. Shaft; Rr.)		UJ331-10
Brute Force Non Greaseable		UJ371	U-Joint (Wheel Joint)Ⓢ	[3]	UJ371
			Brute Force Greaseable		UJ377
			Brute Force Non Greaseable		UJ371

(Continued)

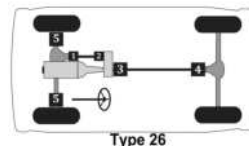

Passenger cars, light & medium trucks

Ford Truck 3/4 ton -- (Cont.)

MFG./YEAR	MODEL & LOCATION	PART NO.	MFG./YEAR	MODEL & LOCATION	PART NO.
Drive Shaft (4 W/D) (Cont.)			Drive Shaft (4 W/D) (Cont.)		
U-Joint (Cont.)			U-Joint (Cont.)		
1996-1990 F250 Reg. Cab w/ 4.9L, 5.0L, 5.8L			1996-1990 F250 Crew Cab w/ 4.9L, 5.0L, 5.8L		
Engs., Inner Lock Ring Wheel Joints & U-Bolts At Trans.: [Type 26]			Engs., Outer Lock Ring Wheel Joints & U-Bolts At Trans.: [Type 26]		
U-Joint (Frt. Shaft; Frt.)Ⓚ		UJ434	U-Joint (Frt. Shaft; Frt.)Ⓚ		UJ434
Brute Force Greaseable		UJ265	Brute Force Greaseable		UJ265
Brute Force Non Greaseable		UJ264	Brute Force Non Greaseable		UJ264
U-Bolt Kit (Frt. Shaft; Frt.)		UJ534-10	U-Bolt Kit (Frt. Shaft; Frt.)		UJ534-10
U-Joint (Frt. Shaft; Rr.)Ⓚ		UJ434	U-Joint (Frt. Shaft; Rr.)Ⓚ		UJ434
Brute Force Greaseable		UJ265	Brute Force Greaseable		UJ265
Brute Force Non Greaseable		UJ264	Brute Force Non Greaseable		UJ264
U-Bolt Kit (Frt. Shaft; Rr.)		UJ534-10	U-Bolt Kit (Frt. Shaft; Rr.)		UJ534-10
U-Joint (Rr. Shaft; Frt.)Ⓚ		UJ434	U-Joint (Rr. Shaft; Frt.)Ⓚ		UJ434
Brute Force Greaseable		UJ265	Brute Force Greaseable		UJ265
Brute Force Non Greaseable		UJ264	Brute Force Non Greaseable		UJ264
U-Bolt Kit (Rr. Shaft; Frt.)		UJ534-10	U-Bolt Kit (Rr. Shaft; Frt.)		UJ534-10
U-Joint (Rr. Shaft; Rr.)Ⓚ		UJ434	U-Joint (Rr. Shaft; Rr.)Ⓚ		UJ434
Brute Force Greaseable		UJ265	Brute Force Greaseable		UJ265
Brute Force Non Greaseable		UJ264	Brute Force Non Greaseable		UJ264
U-Bolt Kit (Rr. Shaft; Rr.)		UJ534-10	U-Bolt Kit (Rr. Shaft; Rr.)		UJ534-10
U-Joint (Wheel Joint)Ⓚ	[3]	UJ371	U-Joint (Wheel Joint)Ⓚ	[3]	UJ231
Brute Force Greaseable		UJ377	(For Aluminum Drive Shaft)		UJ231C
Brute Force Non Greaseable		UJ371			
1996-1990 F250 Crew Cab w/ 4.9L, 5.0L, 5.8L			1996-1990 F250 Reg. Cab w/ 4.9L, 5.0L, 5.8L		
Engs., Outer Lock Ring Wheel Joints w/o U-Bolts At Trans.: [Type 26]			Engs., Inner Lock Ring Wheel Joints & U-Bolts At Trans.: [Type 26]		
U-Joint (Frt. Shaft; Frt.)Ⓚ		UJ434	U-Joint (Frt. Shaft; Frt.)Ⓚ		UJ434
Brute Force Greaseable		UJ265	Brute Force Greaseable		UJ265
Brute Force Non Greaseable		UJ264	Brute Force Non Greaseable		UJ264
U-Bolt Kit (Frt. Shaft; Frt.)		UJ534-10	U-Bolt Kit (Frt. Shaft; Frt.)		UJ534-10
U-Joint (Frt. Shaft; Rr.)Ⓚ		UJ434	U-Joint (Frt. Shaft; Rr.)Ⓚ		UJ434
Brute Force Greaseable		UJ265	Brute Force Greaseable		UJ265
Brute Force Non Greaseable		UJ264	Brute Force Non Greaseable		UJ264
U-Bolt Kit (Frt. Shaft; Rr.)		UJ534-10	U-Bolt Kit (Frt. Shaft; Rr.)		UJ534-10
U-Joint (Rr. Shaft; Frt.)Ⓚ		UJ434	U-Joint (Rr. Shaft; Frt.)Ⓚ		UJ434
Brute Force Greaseable		UJ265	Brute Force Greaseable		UJ265
Brute Force Non Greaseable		UJ264	Brute Force Non Greaseable		UJ264
U-Bolt Kit (Rr. Shaft; Frt.)		UJ534-10	U-Bolt Kit (Rr. Shaft; Frt.)		UJ534-10
U-Joint (Rr. Shaft; Rr.)Ⓚ		UJ434	U-Joint (Rr. Shaft; Rr.)Ⓚ		UJ434
Brute Force Greaseable		UJ265	Brute Force Greaseable		UJ265
Brute Force Non Greaseable		UJ264	Brute Force Non Greaseable		UJ264
U-Bolt Kit (Rr. Shaft; Rr.)		UJ534-10	U-Bolt Kit (Rr. Shaft; Rr.)		UJ534-10
U-Joint (Wheel Joint)Ⓚ	[3]	UJ231	U-Joint (Wheel Joint)Ⓚ	[3]	UJ371
(For Aluminum Drive Shaft)		UJ231C	Brute Force Greaseable		UJ377
			Brute Force Non Greaseable		UJ371

(Continued)

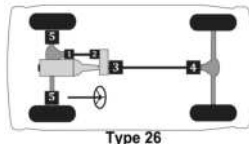

MFG./YEAR	MODEL & LOCATION	PART NO.	MFG./YEAR	MODEL & LOCATION	PART NO.
Drive Shaft (4 W/D) (Cont.)			Drive Shaft (4 W/D) (Cont.)		
U-Joint (Cont.)			U-Joint (Cont.)		
1996-1990 F250 Reg. Cab w/ 4.9L, 5.0L, 5.8L			1996-1990 F250 Reg. Cab w/ 4.9L, 5.0L, 5.8L		
Engs., Inner Lock Ring Wheel Joints			Engs., Outer Lock Ring Wheel Joints		
w/o U-Bolts At Trans.: [Type 26]			w/o U-Bolts At Trans.: [Type 26]		
U-Joint (Frnt. Shaft; Frnt.)ⓐ		UJ434	U-Joint (Frnt. Shaft; Frnt.)ⓐ		UJ434
Brute Force Greaseable		UJ265	Brute Force Greaseable		UJ265
Brute Force Non Greaseable		UJ264	Brute Force Non Greaseable		UJ264
U-Bolt Kit (Frnt. Shaft; Frnt.)		UJ534-10	U-Bolt Kit (Frnt. Shaft; Frnt.)		UJ534-10
U-Joint (Frnt. Shaft; Rr.)ⓑ		UJ434	U-Joint (Frnt. Shaft; Rr.)ⓑ		UJ434
Brute Force Greaseable		UJ265	Brute Force Greaseable		UJ265
Brute Force Non Greaseable		UJ264	Brute Force Non Greaseable		UJ264
U-Bolt Kit (Frnt. Shaft; Rr.)		UJ534-10	U-Bolt Kit (Frnt. Shaft; Rr.)		UJ534-10
U-Joint (Rr. Shaft; Frnt.)ⓐ		UJ434	U-Joint (Rr. Shaft; Frnt.)ⓐ		UJ434
Brute Force Greaseable		UJ265	Brute Force Greaseable		UJ265
Brute Force Non Greaseable		UJ264	Brute Force Non Greaseable		UJ264
U-Bolt Kit (Rr. Shaft; Frnt.)		UJ534-10	U-Bolt Kit (Rr. Shaft; Frnt.)		UJ534-10
U-Joint (Rr. Shaft; Rr.)ⓑ		UJ434	U-Joint (Rr. Shaft; Rr.)ⓑ		UJ434
Brute Force Greaseable		UJ265	Brute Force Greaseable		UJ265
Brute Force Non Greaseable		UJ264	Brute Force Non Greaseable		UJ264
U-Bolt Kit (Rr. Shaft; Rr.)		UJ534-10	U-Bolt Kit (Rr. Shaft; Rr.)		UJ534-10
U-Joint (Wheel Joint)ⓐ	[3]	UJ371	U-Joint (Wheel Joint)ⓐ	[3]	UJ231
Brute Force Greaseable		UJ377	(For Aluminum Drive Shaft)		UJ231C
Brute Force Non Greaseable		UJ371	1996-1990 F250 Reg. Cab w/ 4.9L, 5.0L, 5.8L		
1996-1990 F250 Crew Cab w/ 4.9L, 5.0L, 5.8L			Engs., Outer Lock Ring Wheel Joints		
Engs., Inner Lock Ring Wheel Joints & U-Bolts At Trans.: [Type 26]			& U-Bolts At Trans.: [Type 26]		
U-Joint (Frnt. Shaft; Frnt.)ⓐ		UJ434	U-Joint (Frnt. Shaft; Frnt.)ⓐ		UJ434
Brute Force Greaseable		UJ265	Brute Force Greaseable		UJ265
Brute Force Non Greaseable		UJ264	Brute Force Non Greaseable		UJ264
U-Bolt Kit (Frnt. Shaft; Frnt.)		UJ534-10	U-Bolt Kit (Frnt. Shaft; Frnt.)		UJ534-10
U-Joint (Frnt. Shaft; Rr.)ⓑ		UJ434	U-Joint (Frnt. Shaft; Rr.)ⓑ		UJ434
Brute Force Greaseable		UJ265	Brute Force Greaseable		UJ265
Brute Force Non Greaseable		UJ264	Brute Force Non Greaseable		UJ264
U-Bolt Kit (Frnt. Shaft; Rr.)		UJ534-10	U-Bolt Kit (Frnt. Shaft; Rr.)		UJ534-10
U-Joint (Rr. Shaft; Frnt.)ⓐ		UJ434	U-Joint (Rr. Shaft; Frnt.)ⓐ		UJ434
Brute Force Greaseable		UJ265	Brute Force Greaseable		UJ265
Brute Force Non Greaseable		UJ264	Brute Force Non Greaseable		UJ264
U-Bolt Kit (Rr. Shaft; Frnt.)		UJ534-10	U-Bolt Kit (Rr. Shaft; Frnt.)		UJ534-10
U-Joint (Rr. Shaft; Rr.)ⓑ		UJ434	U-Joint (Rr. Shaft; Rr.)ⓑ		UJ434
Brute Force Greaseable		UJ265	Brute Force Greaseable		UJ265
Brute Force Non Greaseable		UJ264	Brute Force Non Greaseable		UJ264
U-Bolt Kit (Rr. Shaft; Rr.)		UJ534-10	U-Bolt Kit (Rr. Shaft; Rr.)		UJ534-10
U-Joint (Wheel Joint)ⓐ	[3]	UJ371	U-Joint (Wheel Joint)ⓐ	[3]	UJ231
Brute Force Greaseable		UJ377	(For Aluminum Drive Shaft)		UJ231C
Brute Force Non Greaseable		UJ371			(Continued)

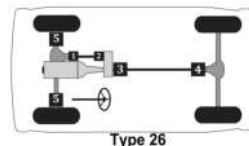

Passenger cars, light & medium trucks

Ford Truck 3/4 ton -- (Cont.)

MFG./YEAR	MODEL & LOCATION	PART NO.	MFG./YEAR	MODEL & LOCATION	PART NO.
Drive Shaft (4 W/D) (Cont.)			Drive Shaft (4 W/D) (Cont.)		
U-Joint (Cont.)			U-Joint (Cont.)		
1996-1990 F250 Ext. Cab w/ 7.3L & 7.5L Engs., Man. Trans. and Outer Lock Ring Wheel Joints: [Type 27]			1996-1990 F250 Ext. Cab w/ 4.9L, 5.0L, 5.8L Engs. & Outer Lock Ring Wheel Joints: [Type 27]		
U-Joint (Fr. Shaft; Frt.)⊙		UJ434	U-Joint (Fr. Shaft; Frt.)⊙		UJ434
Brute Force Greaseable		UJ265	Brute Force Greaseable		UJ265
Brute Force Non Greaseable		UJ264	Brute Force Non Greaseable		UJ264
U-Bolt Kit (Fr. Shaft; Frt.)		UJ534-10	U-Bolt Kit (Fr. Shaft; Frt.)		UJ534-10
U-Joint (Fr. Shaft; Rr.)⊙		UJ434	U-Joint (Fr. Shaft; Rr.)⊙		UJ434
Brute Force Greaseable		UJ265	Brute Force Greaseable		UJ265
Brute Force Non Greaseable		UJ264	Brute Force Non Greaseable		UJ264
U-Bolt Kit (Fr. Shaft; Rr.)		UJ534-10	U-Bolt Kit (Fr. Shaft; Rr.)		UJ534-10
U-Joint (Rr. Shaft; Frt.)⊙		UJ331	U-Joint (Rr. Shaft; Frt.)⊙		UJ434
Brute Force Greaseable		UJ232	Brute Force Greaseable		UJ265
Brute Force Non Greaseable		UJ231	Brute Force Non Greaseable		UJ264
(For Aluminum Drive Shaft)		UJ331C	U-Bolt Kit (Rr. Shaft; Frt.)		UJ534-10
U-Bolt Kit (Rr. Shaft; Frt.)		UJ331-10	U-Joint (Rr. Shaft; Ctr.)⊙		UJ434
U-Joint (Rr. Shaft; Ctr.)⊙		UJ331	Brute Force Greaseable		UJ265
Brute Force Greaseable		UJ232	Brute Force Non Greaseable		UJ264
Brute Force Non Greaseable		UJ231	U-Bolt Kit (Rr. Shaft; Ctr.)		UJ534-10
(For Aluminum Drive Shaft)		UJ331C	U-Joint (Rr. Shaft; Rr.)⊙		UJ434
U-Bolt Kit (Rr. Shaft; Ctr.)		UJ331-10	Brute Force Greaseable		UJ265
U-Joint (Rr. Shaft; Rr.)⊙		UJ331	Brute Force Non Greaseable		UJ264
Brute Force Greaseable		UJ232	U-Bolt Kit (Rr. Shaft; Rr.)		UJ534-10
Brute Force Non Greaseable		UJ231	U-Joint (Wheel Joint)⊙	[3]	UJ231
(For Aluminum Drive Shaft)		UJ331C	(For Aluminum Drive Shaft)		UJ231C
U-Bolt Kit (Rr. Shaft; Rr.)		UJ331-10			(Continued)
U-Joint (Wheel Joint)⊙	[3]	UJ231			
(For Aluminum Drive Shaft)		UJ231C			

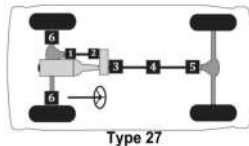

412 ▲ For Use w/ 1.063" Bearing Cap Application. ⊙ For Use w/ 1.188" Bearing Cap Application. ◇ For Use w/ Inner Lock Ring Application on Half Shaft. □ For Use w/ Outer Lock Ring Application on Half Shaft.

Passenger cars, light & medium trucks

(Cont.) -- Ford Truck 3/4 ton

MFG./YEAR	MODEL & LOCATION	PART NO.	MFG./YEAR	MODEL & LOCATION	PART NO.
Drive Shaft (4 W/D) (Cont.)			Drive Shaft (4 W/D) (Cont.)		
U-Joint (Cont.)			U-Joint (Cont.)		
1996-1990 F250 Ext. Cab w/ 7.3L & 7.5L Engs., Auto. Trans. and Outer Lock Ring Wheel Joints: [Type 27]			1996-1990 F250 Ext. Cab w/ 7.3L & 7.5L Engs., Man. Trans. and Inner Lock Ring Wheel Joints: [Type 27]		
	U-Joint (Frnt. Shaft; Frnt.) ^①	UJ434		U-Joint (Frnt. Shaft; Frnt.) ^①	UJ434
	Brute Force Greaseable	UJ265		Brute Force Greaseable	UJ265
	Brute Force Non Greaseable	UJ264		Brute Force Non Greaseable	UJ264
	U-Bolt Kit (Frnt. Shaft; Frnt.)	UJ534-10		U-Bolt Kit (Frnt. Shaft; Frnt.)	UJ534-10
	U-Joint (Frnt. Shaft; Rr.) ^②	UJ434		U-Joint (Frnt. Shaft; Rr.) ^②	UJ434
	Brute Force Greaseable	UJ265		Brute Force Greaseable	UJ265
	Brute Force Non Greaseable	UJ264		Brute Force Non Greaseable	UJ264
	U-Bolt Kit (Frnt. Shaft; Rr.)	UJ534-10		U-Bolt Kit (Frnt. Shaft; Rr.)	UJ534-10
	U-Joint (Rr. Shaft; Frnt.) ^③	UJ434		U-Joint (Rr. Shaft; Frnt.) ^③	UJ331
	Brute Force Greaseable	UJ265		Brute Force Greaseable	UJ232
	Brute Force Non Greaseable	UJ264		Brute Force Non Greaseable	UJ231
	U-Bolt Kit (Rr. Shaft; Frnt.)	UJ534-10		(For Aluminum Drive Shaft)	UJ331C
	U-Joint (Rr. Shaft; Ctr.) ^④	UJ434		U-Bolt Kit (Rr. Shaft; Frnt.)	UJ331-10
	Brute Force Greaseable	UJ265		U-Joint (Rr. Shaft; Ctr.) ^④	UJ331
	Brute Force Non Greaseable	UJ264		Brute Force Greaseable	UJ232
	U-Bolt Kit (Rr. Shaft; Ctr.)	UJ534-10		Brute Force Non Greaseable	UJ231
	U-Joint (Rr. Shaft; Rr.) ^⑤	UJ434		(For Aluminum Drive Shaft)	UJ331C
	Brute Force Greaseable	UJ265		U-Bolt Kit (Rr. Shaft; Ctr.)	UJ331-10
	Brute Force Non Greaseable	UJ264		U-Joint (Rr. Shaft; Rr.) ^⑤	UJ331
	U-Bolt Kit (Rr. Shaft; Rr.)	UJ534-10		Brute Force Greaseable	UJ232
	U-Joint (Wheel Joint) ^⑥	[3] UJ231		Brute Force Non Greaseable	UJ231
	(For Aluminum Drive Shaft)	UJ231C		(For Aluminum Drive Shaft)	UJ331C
				U-Bolt Kit (Rr. Shaft; Rr.)	UJ331-10
				U-Joint (Wheel Joint) ^⑥	[3] UJ371
				Brute Force Greaseable	UJ377
				Brute Force Non Greaseable	UJ371

(Continued)

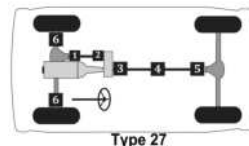

Passenger cars, light & medium trucks

Ford Truck 3/4 ton -- (Cont.)

MFG./YEAR	MODEL & LOCATION	PART NO.	MFG./YEAR	MODEL & LOCATION	PART NO.
Drive Shaft (4 W/D) (Cont.)			Drive Shaft (4 W/D) (Cont.)		
U-Joint (Cont.)			U-Joint (Cont.)		
1996-1990 F250 Ext. Cab w/ 4.9L, 5.0L, 5.8L Engs. & Inner Lock Ring Wheel Joints: [Type 27]			1996-1990 F250 Ext. Cab w/ 7.3L & 7.5L Engs., Auto. Trans. and Inner Lock Ring Wheel Joints: [Type 27]		
U-Joint (Fr. Shaft; Fr.)⊙		UJ434	U-Joint (Fr. Shaft; Fr.)⊙		UJ434
Brute Force Greaseable		UJ265	Brute Force Greaseable		UJ265
Brute Force Non Greaseable		UJ264	Brute Force Non Greaseable		UJ264
U-Bolt Kit (Fr. Shaft; Fr.)		UJ534-10	U-Bolt Kit (Fr. Shaft; Fr.)		UJ534-10
U-Joint (Fr. Shaft; Rr.)⊙		UJ434	U-Joint (Fr. Shaft; Rr.)⊙		UJ434
Brute Force Greaseable		UJ265	Brute Force Greaseable		UJ265
Brute Force Non Greaseable		UJ264	Brute Force Non Greaseable		UJ264
U-Bolt Kit (Fr. Shaft; Rr.)		UJ534-10	U-Bolt Kit (Fr. Shaft; Rr.)		UJ534-10
U-Joint (Rr. Shaft; Fr.)⊙		UJ434	U-Joint (Rr. Shaft; Fr.)⊙		UJ434
Brute Force Greaseable		UJ265	Brute Force Greaseable		UJ265
Brute Force Non Greaseable		UJ264	Brute Force Non Greaseable		UJ264
U-Bolt Kit (Rr. Shaft; Fr.)		UJ534-10	U-Bolt Kit (Rr. Shaft; Fr.)		UJ534-10
U-Joint (Rr. Shaft; Ctr.)⊙		UJ434	U-Joint (Rr. Shaft; Ctr.)⊙		UJ434
Brute Force Greaseable		UJ265	Brute Force Greaseable		UJ265
Brute Force Non Greaseable		UJ264	Brute Force Non Greaseable		UJ264
U-Bolt Kit (Rr. Shaft; Ctr.)		UJ534-10	U-Bolt Kit (Rr. Shaft; Ctr.)		UJ534-10
U-Joint (Rr. Shaft; Rr.)⊙		UJ434	U-Joint (Rr. Shaft; Rr.)⊙		UJ434
Brute Force Greaseable		UJ265	Brute Force Greaseable		UJ265
Brute Force Non Greaseable		UJ264	Brute Force Non Greaseable		UJ264
U-Bolt Kit (Rr. Shaft; Rr.)		UJ534-10	U-Bolt Kit (Rr. Shaft; Rr.)		UJ534-10
U-Joint (Wheel Joint)⊙	[3]	UJ371	U-Joint (Wheel Joint)⊙	[3]	UJ371
Brute Force Greaseable		UJ377	Brute Force Greaseable		UJ377
Brute Force Non Greaseable		UJ371	Brute Force Non Greaseable		UJ371

(Continued)

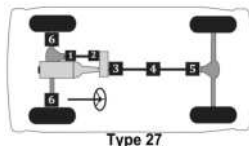

414 ▲ For Use w/ 1.063" Bearing Cap Application. ⊙ For Use w/ 1.188" Bearing Cap Application. ◇ For Use w/ Inner Lock Ring Application on Half Shaft. □ For Use w/ Outer Lock Ring Application on Half Shaft.

Passenger cars, light & medium trucks

(Cont.) -- Ford Truck 3/4 ton

MFG./YEAR	MODEL & LOCATION	PART NO.	MFG./YEAR	MODEL & LOCATION	PART NO.
Drive Shaft (4 W/D) (Cont.)			Drive Shaft (4 W/D) (Cont.)		
U-Joint (Cont.)			U-Joint (Cont.)		
1989	F-250 w/ 2 Joint Shaft, HD 5 Spd. Man. Trans. & Inner Lock Ring Wheel Joints: [Type 36]		1989	F-250 w/ 3 Joint Shaft, HD 5 Spd. Man. Trans. & Inner Lock Ring Wheel Joints: [Type 37]	
	U-Joint (Fr. Shaft; Fr.) ①	UJ434		U-Joint (Fr. Shaft; Fr.) ①	UJ434
	<i>Brute Force Greaseable</i>	UJ265		<i>Brute Force Greaseable</i>	UJ265
	<i>Brute Force Non Greaseable</i>	UJ264		<i>Brute Force Non Greaseable</i>	UJ264
	U-Bolt Kit (Fr. Shaft; Fr.)	UJ534-10		U-Bolt Kit (Fr. Shaft; Fr.)	UJ534-10
	U-Joint (Fr. Shaft; Rr.) ②	UJ434		U-Joint (Fr. Shaft; Rr.) ②	UJ434
	<i>Brute Force Greaseable</i>	UJ265		<i>Brute Force Greaseable</i>	UJ265
	<i>Brute Force Non Greaseable</i>	UJ264		<i>Brute Force Non Greaseable</i>	UJ264
	U-Bolt Kit (Fr. Shaft; Rr.)	UJ534-10		U-Bolt Kit (Fr. Shaft; Rr.)	UJ534-10
	U-Joint (Rr. Shaft; Fr.) ③	UJ331		U-Joint (Rr. Shaft; Fr.) ③	UJ331
	<i>Brute Force Greaseable</i>	UJ232		<i>Brute Force Greaseable</i>	UJ232
	<i>Brute Force Non Greaseable</i>	UJ231		<i>Brute Force Non Greaseable</i>	UJ231
	(For Aluminum Drive Shaft)	UJ331C		(For Aluminum Drive Shaft)	UJ331C
	Clamp Kit (Rr. Shaft; Fr.)	UJ331-10		Clamp Kit (Rr. Shaft; Fr.)	UJ331-10
	U-Joint (Rr. Shaft; Rr.) ④	UJ331		U-Joint (Rr. Shaft; Ctr.) ④	UJ331
	<i>Brute Force Greaseable</i>	UJ232		<i>Brute Force Greaseable</i>	UJ232
	<i>Brute Force Non Greaseable</i>	UJ231		<i>Brute Force Non Greaseable</i>	UJ231
	(For Aluminum Drive Shaft)	UJ331C		(For Aluminum Drive Shaft)	UJ331C
	Clamp Kit (Rr. Shaft; Rr.)	UJ331-10		Clamp Kit (Rr. Shaft; Ctr.)	UJ331-10
	U-Joint (Front Axle Left Outer) ⑤	UJ371		U-Joint (Rr. Shaft; Rr.) ⑤	UJ331
	<i>Brute Force Greaseable</i>	UJ377		<i>Brute Force Greaseable</i>	UJ232
	<i>Brute Force Non Greaseable</i>	UJ371		<i>Brute Force Non Greaseable</i>	UJ231
	U-Joint (Front Axle Right Inner) ⑥	UJ371		(For Aluminum Drive Shaft)	UJ331C
	<i>Brute Force Greaseable</i>	UJ377		Clamp Kit (Rr. Shaft; Rr.)	UJ331-10
	<i>Brute Force Non Greaseable</i>	UJ371		U-Joint (Front Axle Left Outer) ⑥	UJ371
	U-Joint (Front Axle Right Outer) ⑦	UJ371		<i>Brute Force Greaseable</i>	UJ377
	<i>Brute Force Greaseable</i>	UJ377		<i>Brute Force Non Greaseable</i>	UJ371
	<i>Brute Force Non Greaseable</i>	UJ371		U-Joint (Front Axle Right Inner) ⑦	UJ371
				<i>Brute Force Greaseable</i>	UJ377
				<i>Brute Force Non Greaseable</i>	UJ371
				U-Joint (Front Axle Right Outer) ⑧	UJ371
				<i>Brute Force Greaseable</i>	UJ377
				<i>Brute Force Non Greaseable</i>	UJ371

(Continued)

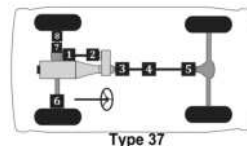
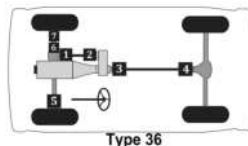

Passenger cars, light & medium trucks

Ford Truck 3/4 ton -- (Cont.)

MFG./YEAR	MODEL & LOCATION	PART NO.	MFG./YEAR	MODEL & LOCATION	PART NO.
Drive Shaft (4 W/D) (Cont.)			Drive Shaft (4 W/D) (Cont.)		
U-Joint (Cont.)			U-Joint (Cont.)		
1989	F-250 w/ 3 Joint Shaft, HD 5 Spd. Man. Trans. & Outer Lock Ring Wheel		1989	F-250 w/ 2 Joint Shaft, HD 5 Spd. Man. Trans. & Outer Lock Ring Wheel	
	Joints: [Type 37]			Joints: [Type 36]	
	U-Joint (Fr. Shaft; Frt.) Ⓚ	UJ434		U-Joint (Fr. Shaft; Frt.) Ⓚ	UJ434
	<i>Brute Force Greaseable</i>	UJ265		<i>Brute Force Greaseable</i>	UJ265
	<i>Brute Force Non Greaseable</i>	UJ264		<i>Brute Force Non Greaseable</i>	UJ264
	U-Bolt Kit (Fr. Shaft; Frt.)	UJ534-10		U-Bolt Kit (Fr. Shaft; Frt.)	UJ534-10
	U-Joint (Fr. Shaft; Rr.) Ⓚ	UJ434		U-Joint (Fr. Shaft; Rr.) Ⓚ	UJ434
	<i>Brute Force Greaseable</i>	UJ265		<i>Brute Force Greaseable</i>	UJ265
	<i>Brute Force Non Greaseable</i>	UJ264		<i>Brute Force Non Greaseable</i>	UJ264
	U-Bolt Kit (Fr. Shaft; Rr.)	UJ534-10		U-Bolt Kit (Fr. Shaft; Rr.)	UJ534-10
	U-Joint (Rr. Shaft; Frt.) Ⓚ	UJ331		U-Joint (Rr. Shaft; Frt.) Ⓚ	UJ331
	<i>Brute Force Greaseable</i>	UJ232		<i>Brute Force Greaseable</i>	UJ232
	<i>Brute Force Non Greaseable</i>	UJ231		<i>Brute Force Non Greaseable</i>	UJ231
	(For Aluminum Drive Shaft)	UJ331C		(For Aluminum Drive Shaft)	UJ331C
	Clamp Kit (Rr. Shaft; Frt.)	UJ331-10		Clamp Kit (Rr. Shaft; Frt.)	UJ331-10
	U-Joint (Rr. Shaft; Ctr.) Ⓚ	UJ331		U-Joint (Rr. Shaft; Rr.) Ⓚ	UJ331
	<i>Brute Force Greaseable</i>	UJ232		<i>Brute Force Greaseable</i>	UJ232
	<i>Brute Force Non Greaseable</i>	UJ231		<i>Brute Force Non Greaseable</i>	UJ231
	(For Aluminum Drive Shaft)	UJ331C		(For Aluminum Drive Shaft)	UJ331C
	Clamp Kit (Rr. Shaft; Ctr.)	UJ331-10		Clamp Kit (Rr. Shaft; Rr.)	UJ331-10
	U-Joint (Rr. Shaft; Rr.) Ⓚ	UJ331		U-Joint (Front Axle Left Outer) Ⓚ	UJ231
	<i>Brute Force Greaseable</i>	UJ232		(For Aluminum Drive Shaft)	UJ231C
	<i>Brute Force Non Greaseable</i>	UJ231		U-Joint (Front Axle Right Inner) Ⓚ	UJ231
	(For Aluminum Drive Shaft)	UJ331C		(For Aluminum Drive Shaft)	UJ231C
	Clamp Kit (Rr. Shaft; Rr.)	UJ331-10		U-Joint (Front Axle Right Outer) Ⓚ	UJ231
	U-Joint (Front Axle Left Outer) Ⓚ	UJ231		(For Aluminum Drive Shaft)	UJ231C
	(For Aluminum Drive Shaft)	UJ231C			
	U-Joint (Front Axle Right Inner) Ⓚ	UJ231			
	(For Aluminum Drive Shaft)	UJ231C			
	U-Joint (Front Axle Right Outer) Ⓚ	UJ231			
	(For Aluminum Drive Shaft)	UJ231C			

(Continued)

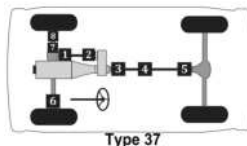
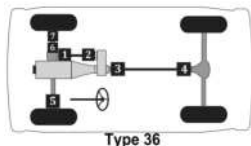

Passenger cars, light & medium trucks

(Cont.) -- Ford Truck 3/4 ton

MFG./YEAR	MODEL & LOCATION	PART NO.	MFG./YEAR	MODEL & LOCATION	PART NO.
Drive Shaft (4 W/D) (Cont.)			Drive Shaft (4 W/D) (Cont.)		
U-Joint (Cont.)			U-Joint (Cont.)		
1989-1988 F-250 w/ 2 Joint Shaft & Inner Lock			1989-1988 F-250 w/ 3 Joint Shaft & Inner Lock		
Ring Wheel Joints Exc. HD 5 Spd.			Ring Wheel Joints Exc. HD 5 Spd.		
Man. Trans.: [Type 36]			Man. Trans.: [Type 37]		
	U-Joint (Frnt. Shaft; Frnt.) ❶	UJ434		U-Joint (Frnt. Shaft; Frnt.) ❶	UJ434
	<i>Brute Force Greaseable</i>	UJ265		<i>Brute Force Greaseable</i>	UJ265
	<i>Brute Force Non Greaseable</i>	UJ264		<i>Brute Force Non Greaseable</i>	UJ264
	U-Bolt Kit (Frnt. Shaft; Frnt.)	UJ534-10		U-Bolt Kit (Frnt. Shaft; Frnt.)	UJ534-10
	U-Joint (Frnt. Shaft; Rr.) ❷	UJ434		U-Joint (Frnt. Shaft; Rr.) ❷	UJ434
	<i>Brute Force Greaseable</i>	UJ265		<i>Brute Force Greaseable</i>	UJ265
	<i>Brute Force Non Greaseable</i>	UJ264		<i>Brute Force Non Greaseable</i>	UJ264
	U-Bolt Kit (Frnt. Shaft; Rr.)	UJ534-10		U-Bolt Kit (Frnt. Shaft; Rr.)	UJ534-10
	U-Joint (Rr. Shaft; Frnt.) ❸	UJ354		U-Joint (Rr. Shaft; Frnt.) ❸	UJ354
	<i>Brute Force Greaseable</i>	UJ270		<i>Brute Force Greaseable</i>	UJ270
	<i>Brute Force Non Greaseable</i>	UJ254		<i>Brute Force Non Greaseable</i>	UJ254
	(For Aluminum Drive Shaft)	UJ354C		(For Aluminum Drive Shaft)	UJ354C
	U-Joint (Rr. Shaft; Rr.) ❹	UJ434		U-Joint (Rr. Shaft; Rr.) ❹	UJ434
	<i>Brute Force Greaseable</i>	UJ265		<i>Brute Force Greaseable</i>	UJ270
	<i>Brute Force Non Greaseable</i>	UJ264		<i>Brute Force Non Greaseable</i>	UJ254
	U-Bolt Kit (Rr. Shaft; Rr.)	UJ534-10		(For Aluminum Drive Shaft)	UJ354C
	U-Joint (Front Axle Left Outer) ❺	UJ371		U-Joint (Rr. Shaft; Rr.) ❺	UJ434
	<i>Brute Force Greaseable</i>	UJ377		<i>Brute Force Greaseable</i>	UJ265
	<i>Brute Force Non Greaseable</i>	UJ371		<i>Brute Force Non Greaseable</i>	UJ264
	U-Joint (Front Axle Right Inner) ❻	UJ371		U-Bolt Kit (Rr. Shaft; Rr.)	UJ534-10
	<i>Brute Force Greaseable</i>	UJ377		U-Joint (Front Axle Left Outer) ❻	UJ371
	<i>Brute Force Non Greaseable</i>	UJ371		<i>Brute Force Greaseable</i>	UJ377
	U-Joint (Front Axle Right Outer) ❼	UJ371		<i>Brute Force Non Greaseable</i>	UJ371
	<i>Brute Force Greaseable</i>	UJ377		U-Joint (Front Axle Right Inner) ❼	UJ371
	<i>Brute Force Non Greaseable</i>	UJ371		<i>Brute Force Greaseable</i>	UJ377
				<i>Brute Force Non Greaseable</i>	UJ371
				U-Joint (Front Axle Right Outer) ❽	UJ371
				<i>Brute Force Greaseable</i>	UJ377
				<i>Brute Force Non Greaseable</i>	UJ371
				<i>Brute Force Non Greaseable</i>	UJ371

(Continued)

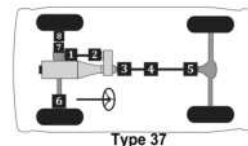
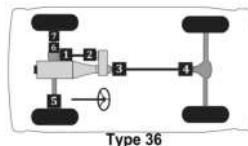

Passenger cars, light & medium trucks

Ford Truck 3/4 ton -- (Cont.)

MFG./YEAR	MODEL & LOCATION	PART NO.	MFG./YEAR	MODEL & LOCATION	PART NO.
Drive Shaft (4 W/D) (Cont.)			Drive Shaft (4 W/D) (Cont.)		
U-Joint (Cont.)			U-Joint (Cont.)		
1989-1988 F-250 w/ 3 Joint Shaft & Outer Lock			1989-1988 F-250 w/ 2 Joint Shaft & Outer Lock		
Ring Wheel Joints Exc. HD 5 Spd.			Ring Wheel Joints Exc. HD 5 Spd.		
Man. Trans.: [Type 37]			Man. Trans.: [Type 36]		
U-Joint (Fr. Shaft; Frt.) ^①		UJ434	U-Joint (Fr. Shaft; Frt.) ^①		UJ434
Brute Force Greaseable		UJ265	Brute Force Greaseable		UJ265
Brute Force Non Greaseable		UJ264	Brute Force Non Greaseable		UJ264
U-Bolt Kit (Fr. Shaft; Frt.)		UJ534-10	U-Bolt Kit (Fr. Shaft; Frt.)		UJ534-10
U-Joint (Fr. Shaft; Rr.) ^②		UJ434	U-Joint (Fr. Shaft; Rr.) ^②		UJ434
Brute Force Greaseable		UJ265	Brute Force Greaseable		UJ265
Brute Force Non Greaseable		UJ264	Brute Force Non Greaseable		UJ264
U-Bolt Kit (Fr. Shaft; Rr.)		UJ534-10	U-Bolt Kit (Fr. Shaft; Rr.)		UJ534-10
U-Joint (Rr. Shaft; Frt.) ^③		UJ354	U-Joint (Rr. Shaft; Frt.) ^③		UJ354
Brute Force Greaseable		UJ270	Brute Force Greaseable		UJ270
Brute Force Non Greaseable		UJ254	Brute Force Non Greaseable		UJ254
(For Aluminum Drive Shaft)		UJ354C	(For Aluminum Drive Shaft)		UJ354C
U-Joint (Rr. Shaft; Ctr.) ^④		UJ354	U-Joint (Rr. Shaft; Rr.) ^④		UJ434
Brute Force Greaseable		UJ270	Brute Force Greaseable		UJ265
Brute Force Non Greaseable		UJ254	Brute Force Non Greaseable		UJ264
(For Aluminum Drive Shaft)		UJ354C	U-Bolt Kit (Rr. Shaft; Rr.)		UJ534-10
U-Joint (Rr. Shaft; Rr.) ^⑤		UJ434	U-Joint (Front Axle Left Outer) ^⑥		UJ231
Brute Force Greaseable		UJ265	(For Aluminum Drive Shaft)		UJ231C
Brute Force Non Greaseable		UJ264	U-Joint (Front Axle Right Inner) ^⑥		UJ231
U-Bolt Kit (Rr. Shaft; Rr.)		UJ534-10	(For Aluminum Drive Shaft)		UJ231C
U-Joint (Front Axle Left Outer) ^⑥		UJ231	U-Joint (Front Axle Right Outer) ^⑦		UJ231
(For Aluminum Drive Shaft)		UJ231C	(For Aluminum Drive Shaft)		UJ231C
U-Joint (Front Axle Right Inner) ^⑥		UJ231			(Continued)
(For Aluminum Drive Shaft)		UJ231C			
U-Joint (Front Axle Right Outer) ^⑥		UJ231			
(For Aluminum Drive Shaft)		UJ231C			

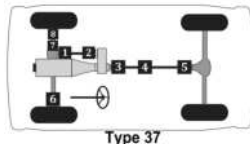
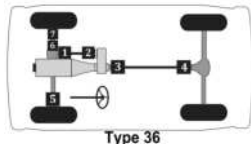

418 ▲ For Use w/ 1.063" Bearing Cap Application. ⊙ For Use w/ 1.188" Bearing Cap Application. ◇ For Use w/ Inner Lock Ring Application on Half Shaft. □ For Use w/ Outer Lock Ring Application on Half Shaft.

Passenger cars, light & medium trucks

(Cont.) -- Ford Truck 3/4 ton

MFG./YEAR	MODEL & LOCATION	PART NO.	MFG./YEAR	MODEL & LOCATION	PART NO.
Drive Shaft (4 W/D) (Cont.)			Drive Shaft (4 W/D) (Cont.)		
U-Joint (Cont.)			U-Joint (Cont.)		
1988	F-250 w/ Reg. Cab, 4.9L, 5.8L Engs., HD 5 Spd. Man. Trans. & Inner Lock Ring Wheel Joints: [Type 36]		1988	F-250 w/ Reg. Cab, 7.3L, 7.5L Engs., HD 5 Spd. Man. Trans. & Inner Lock Ring Wheel Joints: [Type 36]	
	U-Joint (Frnt. Shaft; Frt.) ①	UJ434		U-Joint (Frnt. Shaft; Frt.) ①	UJ434
	<i>Brute Force Greaseable</i>	UJ265		<i>Brute Force Greaseable</i>	UJ265
	<i>Brute Force Non Greaseable</i>	UJ264		<i>Brute Force Non Greaseable</i>	UJ264
	U-Bolt Kit (Frnt. Shaft; Frt.)	UJ534-10		U-Bolt Kit (Frnt. Shaft; Frt.)	UJ534-10
	U-Joint (Frnt. Shaft; Rr.) ②	UJ434		U-Joint (Frnt. Shaft; Rr.) ②	UJ434
	<i>Brute Force Greaseable</i>	UJ265		<i>Brute Force Greaseable</i>	UJ265
	<i>Brute Force Non Greaseable</i>	UJ264		<i>Brute Force Non Greaseable</i>	UJ264
	U-Bolt Kit (Frnt. Shaft; Rr.)	UJ534-10		U-Bolt Kit (Frnt. Shaft; Rr.)	UJ534-10
	U-Joint (Rr. Shaft; Frt.) ③	UJ354		U-Joint (Rr. Shaft; Frt.) ③	UJ331
	<i>Brute Force Greaseable</i>	UJ270		<i>Brute Force Greaseable</i>	UJ232
	<i>Brute Force Non Greaseable</i>	UJ254		<i>Brute Force Non Greaseable</i>	UJ231
	(For Aluminum Drive Shaft)	UJ354C		(For Aluminum Drive Shaft)	UJ331C
	U-Joint (Rr. Shaft; Rr.) ④	UJ434		U-Joint (Rr. Shaft; Rr.) ④	UJ331-10
	<i>Brute Force Greaseable</i>	UJ265		<i>Brute Force Greaseable</i>	UJ331
	<i>Brute Force Non Greaseable</i>	UJ264		<i>Brute Force Non Greaseable</i>	UJ232
	U-Bolt Kit (Rr. Shaft; Rr.)	UJ534-10		<i>Brute Force Non Greaseable</i>	UJ231
	U-Joint (Front Axle Left Outer) ⑤	UJ371		(For Aluminum Drive Shaft)	UJ331C
	<i>Brute Force Greaseable</i>	UJ377		Clamp Kit (Rr. Shaft; Frt.)	UJ331-10
	<i>Brute Force Non Greaseable</i>	UJ371		U-Joint (Rr. Shaft; Rr.) ④	UJ331
	U-Joint (Front Axle Right Inner) ⑥	UJ371		<i>Brute Force Greaseable</i>	UJ232
	<i>Brute Force Greaseable</i>	UJ377		<i>Brute Force Non Greaseable</i>	UJ231
	<i>Brute Force Non Greaseable</i>	UJ371		(For Aluminum Drive Shaft)	UJ331C
	U-Joint (Front Axle Right Outer) ⑦	UJ371		Clamp Kit (Rr. Shaft; Rr.)	UJ331-10
	<i>Brute Force Greaseable</i>	UJ377		U-Joint (Front Axle Left Outer) ⑤	UJ371
	<i>Brute Force Non Greaseable</i>	UJ371		<i>Brute Force Greaseable</i>	UJ377
				<i>Brute Force Non Greaseable</i>	UJ371
				U-Joint (Front Axle Right Inner) ⑥	UJ371
				<i>Brute Force Greaseable</i>	UJ377
				<i>Brute Force Non Greaseable</i>	UJ371
				U-Joint (Front Axle Right Outer) ⑦	UJ371
				<i>Brute Force Greaseable</i>	UJ377
				<i>Brute Force Non Greaseable</i>	UJ371
				<i>Brute Force Non Greaseable</i>	UJ371

(Continued)

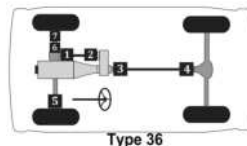

Passenger cars, light & medium trucks

Ford Truck 3/4 ton -- (Cont.)

MFG./YEAR	MODEL & LOCATION	PART NO.	MFG./YEAR	MODEL & LOCATION	PART NO.
Drive Shaft (4 W/D) (Cont.)			Drive Shaft (4 W/D) (Cont.)		
U-Joint (Cont.)			U-Joint (Cont.)		
1988	F-250 w/ Crew Cab, 5.8L Eng., HD 5 Spd. Man. Trans. Inner Lock Ring Wheel Joints: [Type 37]		1988	F-250 w/ Crew Cab, 7.3L, 7.5L Engs., HD 5 Spd. Man. Trans. Inner Lock Ring Wheel Joints: [Type 37]	
	U-Joint (Frt. Shaft; Frt.) ⓐ	UJ434		U-Joint (Frt. Shaft; Frt.) ⓐ	UJ434
	Brute Force Greaseable	UJ265		Brute Force Greaseable	UJ265
	Brute Force Non Greaseable	UJ264		Brute Force Non Greaseable	UJ264
	U-Bolt Kit (Frt. Shaft; Frt.)	UJ534-10		U-Bolt Kit (Frt. Shaft; Frt.)	UJ534-10
	U-Joint (Frt. Shaft; Rr.) ⓐ	UJ434		U-Joint (Frt. Shaft; Rr.) ⓐ	UJ434
	Brute Force Greaseable	UJ265		Brute Force Greaseable	UJ265
	Brute Force Non Greaseable	UJ264		Brute Force Non Greaseable	UJ264
	U-Bolt Kit (Frt. Shaft; Rr.)	UJ534-10		U-Bolt Kit (Frt. Shaft; Rr.)	UJ534-10
	U-Joint (Rr. Shaft; Frt.) ⓐ	UJ354		U-Joint (Rr. Shaft; Frt.) ⓐ	UJ331
	Brute Force Greaseable	UJ270		Brute Force Greaseable	UJ232
	Brute Force Non Greaseable	UJ254		Brute Force Non Greaseable	UJ231
	(For Aluminum Drive Shaft)	UJ354C		(For Aluminum Drive Shaft)	UJ331C
	U-Joint (Rr. Shaft; Ctr.) ⓐ	UJ354		U-Joint (Rr. Shaft; Ctr.) ⓐ	UJ331-10
	Brute Force Greaseable	UJ270		Brute Force Greaseable	UJ331
	Brute Force Non Greaseable	UJ254		Brute Force Non Greaseable	UJ232
	(For Aluminum Drive Shaft)	UJ354C		(For Aluminum Drive Shaft)	UJ231
	U-Joint (Rr. Shaft; Rr.) ⓐ	UJ434		U-Joint (Rr. Shaft; Rr.) ⓐ	UJ331
	Brute Force Greaseable	UJ265		Brute Force Greaseable	UJ232
	Brute Force Non Greaseable	UJ264		Brute Force Non Greaseable	UJ231
	U-Bolt Kit (Rr. Shaft; Rr.)	UJ534-10		U-Bolt Kit (Rr. Shaft; Rr.)	UJ331-10
	U-Joint (Front Axle Left Outer) ⓐ	UJ371		U-Joint (Front Axle Left Outer) ⓐ	UJ371
	Brute Force Greaseable	UJ377		Brute Force Greaseable	UJ377
	Brute Force Non Greaseable	UJ371		Brute Force Non Greaseable	UJ371
	U-Joint (Front Axle Right Inner) ⓐ	UJ371		U-Joint (Front Axle Right Inner) ⓐ	UJ371
	Brute Force Greaseable	UJ377		Brute Force Greaseable	UJ377
	Brute Force Non Greaseable	UJ371		Brute Force Non Greaseable	UJ371
	U-Joint (Front Axle Right Outer) ⓐ	UJ371		U-Joint (Front Axle Right Outer) ⓐ	UJ371
	Brute Force Greaseable	UJ377		Brute Force Greaseable	UJ377
	Brute Force Non Greaseable	UJ371		Brute Force Non Greaseable	UJ371

(Continued)

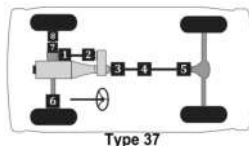

420 ▲ For Use w/ 1.063" Bearing Cap Application. ⓐ For Use w/ 1.188" Bearing Cap Application. ◇ For Use w/ Inner Lock Ring Application on Half Shaft. □ For Use w/ Outer Lock Ring Application on Half Shaft.



Passenger cars, light & medium trucks

(Cont.) -- Ford Truck 3/4 ton

MFG./YEAR	MODEL & LOCATION	PART NO.	MFG./YEAR	MODEL & LOCATION	PART NO.
Drive Shaft (4 W/D) (Cont.)			Drive Shaft (4 W/D) (Cont.)		
U-Joint (Cont.)			U-Joint (Cont.)		
1988	F-250 w/ Crew Cab, 7.3L, 7.5L Engs., HD 5 Spd. Man. Trans. Outer Lock Ring Wheel Joints: [Type 37]		1988	F-250 w/ Crew Cab, 5.8L Eng., HD 5 Spd. Man. Trans. Outer Lock Ring Wheel Joints: [Type 37]	
	U-Joint (Frt. Shaft; Frt.) ①	UJ434		U-Joint (Frt. Shaft; Frt.) ①	UJ434
	<i>Brute Force Greaseable</i>	UJ265		<i>Brute Force Greaseable</i>	UJ265
	<i>Brute Force Non Greaseable</i>	UJ264		<i>Brute Force Non Greaseable</i>	UJ264
	U-Bolt Kit (Frt. Shaft; Frt.)	UJ534-10		U-Bolt Kit (Frt. Shaft; Frt.)	UJ534-10
	U-Joint (Frt. Shaft; Rr.) ②	UJ434		U-Joint (Frt. Shaft; Rr.) ②	UJ434
	<i>Brute Force Greaseable</i>	UJ265		<i>Brute Force Greaseable</i>	UJ265
	<i>Brute Force Non Greaseable</i>	UJ264		<i>Brute Force Non Greaseable</i>	UJ264
	U-Bolt Kit (Frt. Shaft; Rr.)	UJ534-10		U-Bolt Kit (Frt. Shaft; Rr.)	UJ534-10
	U-Joint (Rr. Shaft; Frt.) ③	UJ331		U-Joint (Rr. Shaft; Frt.) ③	UJ354
	<i>Brute Force Greaseable</i>	UJ232		<i>Brute Force Greaseable</i>	UJ270
	<i>Brute Force Non Greaseable</i>	UJ231		<i>Brute Force Non Greaseable</i>	UJ254
	(For Aluminum Drive Shaft)	UJ331C		(For Aluminum Drive Shaft)	UJ354C
	Clamp Kit (Rr. Shaft; Frt.)	UJ331-10		U-Joint (Rr. Shaft; Ctr.) ④	UJ354
	U-Joint (Rr. Shaft; Ctr.) ④	UJ331		<i>Brute Force Greaseable</i>	UJ270
	<i>Brute Force Greaseable</i>	UJ232		<i>Brute Force Non Greaseable</i>	UJ254
	<i>Brute Force Non Greaseable</i>	UJ231		(For Aluminum Drive Shaft)	UJ354C
	(For Aluminum Drive Shaft)	UJ331C		U-Joint (Rr. Shaft; Rr.) ⑤	UJ434
	Clamp Kit (Rr. Shaft; Ctr.)	UJ331-10		<i>Brute Force Greaseable</i>	UJ265
	U-Joint (Rr. Shaft; Rr.) ⑤	UJ331		<i>Brute Force Non Greaseable</i>	UJ264
	<i>Brute Force Greaseable</i>	UJ232		U-Bolt Kit (Rr. Shaft; Rr.)	UJ534-10
	<i>Brute Force Non Greaseable</i>	UJ231		U-Joint (Front Axle Left Outer) ⑥	UJ231
	(For Aluminum Drive Shaft)	UJ331C		(For Aluminum Drive Shaft)	UJ231C
	Clamp Kit (Rr. Shaft; Rr.)	UJ331-10		U-Joint (Front Axle Right Inner) ⑦	UJ231
	U-Joint (Front Axle Left Outer) ⑥	UJ231		(For Aluminum Drive Shaft)	UJ231C
	(For Aluminum Drive Shaft)	UJ231C		U-Joint (Front Axle Right Outer) ⑧	UJ231
	U-Joint (Front Axle Right Inner) ⑦	UJ231		(For Aluminum Drive Shaft)	UJ231C
	(For Aluminum Drive Shaft)	UJ231C			(Continued)
	U-Joint (Front Axle Right Outer) ⑧	UJ231			
	(For Aluminum Drive Shaft)	UJ231C			

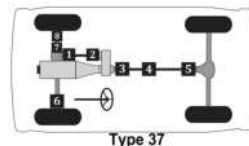

Passenger cars, light & medium trucks

Ford Truck 3/4 ton -- (Cont.)

MFG./YEAR	MODEL & LOCATION	PART NO.	MFG./YEAR	MODEL & LOCATION	PART NO.
Drive Shaft (4 W/D) (Cont.)			Drive Shaft (4 W/D) (Cont.)		
U-Joint (Cont.)			U-Joint (Cont.)		
1988	F-250 w/ Reg. Cab, 7.3L, 7.5L Engs., HD 5 Spd. Man. Trans. & Outer Lock Ring Wheel Joints: [Type 36]		1988	F-250 w/ Reg. Cab, 4.9L, 5.8L Engs., HD 5 Spd. Man. Trans. & Outer Lock Ring Wheel Joints: [Type 36]	
	U-Joint (Fr. Shaft; Frt.) Ⓐ	UJ434		U-Joint (Fr. Shaft; Frt.) Ⓐ	UJ434
	<i>Brute Force Greaseable</i>	UJ265		<i>Brute Force Greaseable</i>	UJ265
	<i>Brute Force Non Greaseable</i>	UJ264		<i>Brute Force Non Greaseable</i>	UJ264
	U-Bolt Kit (Fr. Shaft; Frt.)	UJ534-10		U-Bolt Kit (Fr. Shaft; Frt.)	UJ534-10
	U-Joint (Fr. Shaft; Rr.) Ⓐ	UJ434		U-Joint (Fr. Shaft; Rr.) Ⓐ	UJ434
	<i>Brute Force Greaseable</i>	UJ265		<i>Brute Force Greaseable</i>	UJ265
	<i>Brute Force Non Greaseable</i>	UJ264		<i>Brute Force Non Greaseable</i>	UJ264
	U-Bolt Kit (Fr. Shaft; Rr.)	UJ534-10		U-Bolt Kit (Fr. Shaft; Rr.)	UJ534-10
	U-Joint (Rr. Shaft; Frt.) Ⓐ	UJ331		U-Joint (Rr. Shaft; Frt.) Ⓐ	UJ354
	<i>Brute Force Greaseable</i>	UJ232		<i>Brute Force Greaseable</i>	UJ270
	<i>Brute Force Non Greaseable</i>	UJ231		<i>Brute Force Non Greaseable</i>	UJ254
	(For Aluminum Drive Shaft)	UJ331C		(For Aluminum Drive Shaft)	UJ354C
	Clamp Kit (Rr. Shaft; Frt.)	UJ331-10		U-Joint (Rr. Shaft; Rr.) Ⓐ	UJ434
	U-Joint (Rr. Shaft; Rr.) Ⓐ	UJ331		<i>Brute Force Greaseable</i>	UJ265
	<i>Brute Force Greaseable</i>	UJ232		<i>Brute Force Non Greaseable</i>	UJ264
	<i>Brute Force Non Greaseable</i>	UJ231		U-Bolt Kit (Rr. Shaft; Rr.)	UJ534-10
	(For Aluminum Drive Shaft)	UJ331C		U-Joint (Front Axle Left Outer) Ⓐ	UJ231
	Clamp Kit (Rr. Shaft; Rr.)	UJ331-10		(For Aluminum Drive Shaft)	UJ231C
	U-Joint (Front Axle Left Outer) Ⓐ	UJ231		U-Joint (Front Axle Right Inner) Ⓐ	UJ231
	(For Aluminum Drive Shaft)	UJ231C		(For Aluminum Drive Shaft)	UJ231C
	U-Joint (Front Axle Right Inner) Ⓐ	UJ231		U-Joint (Front Axle Right Outer) Ⓐ	UJ231
	(For Aluminum Drive Shaft)	UJ231C		(For Aluminum Drive Shaft)	UJ231C
	U-Joint (Front Axle Right Outer) Ⓐ	UJ231			
	(For Aluminum Drive Shaft)	UJ231C			(Continued)

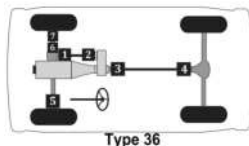

422 ▲ For Use w/ 1.063" Bearing Cap Application. Ⓐ For Use w/ 1.188" Bearing Cap Application. ◇ For Use w/ Inner Lock Ring Application on Half Shaft. □ For Use w/ Outer Lock Ring Application on Half Shaft.

Passenger cars, light & medium trucks

(Cont.) -- Ford Truck 3/4 ton

MFG./YEAR	MODEL & LOCATION	PART NO.	MFG./YEAR	MODEL & LOCATION	PART NO.
Drive Shaft (4 W/D) (Cont.)			Drive Shaft (4 W/D) (Cont.)		
U-Joint (Cont.)			U-Joint (Cont.)		
1987	F-250 w/ 2 Joint Shaft, 5 Spd. Man. Trans. & Inner Lock Ring Wheel Joints: [Type 36]		1987	F-250 w/ 2 Joint Shaft & Inner Lock Ring Wheel Joints Exc. 5 Spd. Man. Trans.: [Type 36]	
	U-Joint (Frt. Shaft; Frt.) ①	UJ434		U-Joint (Frt. Shaft; Frt.) ①	UJ434
	<i>Brute Force Greaseable</i>	UJ265		<i>Brute Force Greaseable</i>	UJ265
	<i>Brute Force Non Greaseable</i>	UJ264		<i>Brute Force Non Greaseable</i>	UJ264
	U-Bolt Kit (Frt. Shaft; Frt.)	UJ534-10		U-Bolt Kit (Frt. Shaft; Frt.)	UJ534-10
	U-Joint (Frt. Shaft; Rr.) ②	UJ354		U-Joint (Frt. Shaft; Rr.) ②	UJ354
	<i>Brute Force Greaseable</i>	UJ270		<i>Brute Force Greaseable</i>	UJ270
	<i>Brute Force Non Greaseable</i>	UJ254		<i>Brute Force Non Greaseable</i>	UJ254
	(For Aluminum Drive Shaft)	UJ354C		(For Aluminum Drive Shaft)	UJ354C
	U-Joint (Rr. Shaft; Frt.) ③	UJ331		U-Joint (Rr. Shaft; Frt.) ③	UJ331
	<i>Brute Force Greaseable</i>	UJ232		<i>Brute Force Greaseable</i>	UJ270
	<i>Brute Force Non Greaseable</i>	UJ231		<i>Brute Force Non Greaseable</i>	UJ254
	(For Aluminum Drive Shaft)	UJ331C		(For Aluminum Drive Shaft)	UJ354C
	Clamp Kit (Rr. Shaft; Frt.)	UJ331-10		U-Joint (Rr. Shaft; Rr.) ④	UJ434
	U-Joint (Rr. Shaft; Rr.) ④	UJ331		<i>Brute Force Greaseable</i>	UJ265
	<i>Brute Force Greaseable</i>	UJ232		<i>Brute Force Non Greaseable</i>	UJ264
	<i>Brute Force Non Greaseable</i>	UJ231		U-Bolt Kit (Rr. Shaft; Rr.)	UJ534-10
	(For Aluminum Drive Shaft)	UJ331C		U-Joint (Front Axle Left Outer) ⑤	[3] UJ371
	Clamp Kit (Rr. Shaft; Rr.)	UJ331-10		<i>Brute Force Greaseable</i>	UJ377
	U-Joint (Front Axle Left Outer) ⑤	UJ371		<i>Brute Force Non Greaseable</i>	UJ371
	<i>Brute Force Greaseable</i>	UJ377		U-Joint (Front Axle Right Inner) ⑥	UJ371
	<i>Brute Force Non Greaseable</i>	UJ371		<i>Brute Force Greaseable</i>	UJ377
	U-Joint (Front Axle Right Inner) ⑥	UJ371		<i>Brute Force Non Greaseable</i>	UJ371
	<i>Brute Force Greaseable</i>	UJ377		U-Joint (Front Axle Right Outer) ⑦	UJ371
	<i>Brute Force Non Greaseable</i>	UJ371		<i>Brute Force Greaseable</i>	UJ377
	U-Joint (Front Axle Right Outer) ⑦	UJ371		<i>Brute Force Non Greaseable</i>	UJ371
	<i>Brute Force Greaseable</i>	UJ377			
	<i>Brute Force Non Greaseable</i>	UJ371			(Continued)

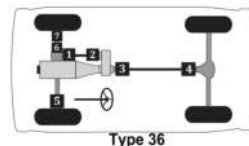

Passenger cars, light & medium trucks

Ford Truck 3/4 ton -- (Cont.)

MFG./YEAR	MODEL & LOCATION	PART NO.	MFG./YEAR	MODEL & LOCATION	PART NO.
Drive Shaft (4 W/D) (Cont.)			Drive Shaft (4 W/D) (Cont.)		
U-Joint (Cont.)			U-Joint (Cont.)		
1987	F-250 w/ 3 Joint Shaft & Inner Lock		1987	F-250 w/ 3 Joint Shaft & Outer Lock	
	Ring Wheel Joints: [Type 37]			Ring Wheel Joints: [Type 37]	
	U-Joint (Fr. Shaft; Fr.) [ⓐ]	UJ434		U-Joint (Fr. Shaft; Fr.) [ⓐ]	UJ434
	Brute Force Greaseable	UJ265		Brute Force Greaseable	UJ265
	Brute Force Non Greaseable	UJ264		Brute Force Non Greaseable	UJ264
	U-Bolt Kit (Fr. Shaft; Fr.)	UJ534-10		U-Bolt Kit (Fr. Shaft; Fr.)	UJ534-10
	U-Joint (Fr. Shaft; Rr.) [ⓑ]	UJ354		U-Joint (Fr. Shaft; Rr.) [ⓑ]	UJ354
	Brute Force Greaseable	UJ270		Brute Force Greaseable	UJ270
	Brute Force Non Greaseable	UJ254		Brute Force Non Greaseable	UJ254
	(For Aluminum Drive Shaft)	UJ354C		(For Aluminum Drive Shaft)	UJ354C
	U-Joint (Rr. Shaft; Fr.) [ⓐ]	UJ434		U-Joint (Rr. Shaft; Fr.) [ⓐ]	UJ434
	Brute Force Greaseable	UJ265		Brute Force Greaseable	UJ265
	Brute Force Non Greaseable	UJ264		Brute Force Non Greaseable	UJ264
	U-Bolt Kit (Rr. Shaft; Fr.)	UJ534-10		U-Bolt Kit (Rr. Shaft; Fr.)	UJ534-10
	U-Joint (Rr. Shaft; Ctr.) [ⓐ]	UJ354		U-Joint (Rr. Shaft; Ctr.) [ⓐ]	UJ354
	Brute Force Greaseable	UJ270		Brute Force Greaseable	UJ270
	Brute Force Non Greaseable	UJ254		Brute Force Non Greaseable	UJ254
	(For Aluminum Drive Shaft)	UJ354C		(For Aluminum Drive Shaft)	UJ354C
	U-Joint (Rr. Shaft; Rr.) [ⓑ]	UJ434		U-Joint (Rr. Shaft; Rr.) [ⓑ]	UJ434
	Brute Force Greaseable	UJ265		Brute Force Greaseable	UJ265
	Brute Force Non Greaseable	UJ264		Brute Force Non Greaseable	UJ264
	U-Bolt Kit (Rr. Shaft; Rr.)	UJ534-10		U-Bolt Kit (Rr. Shaft; Rr.)	UJ534-10
	U-Joint (Front Axle Left Outer) [ⓐ]	UJ371		U-Joint (Front Axle Left Outer) [ⓐ]	UJ231
	Brute Force Greaseable	UJ377		(For Aluminum Drive Shaft)	UJ231C
	Brute Force Non Greaseable	UJ371		U-Joint (Front Axle Right Inner) [ⓑ]	UJ231
	U-Joint (Front Axle Right Inner) [ⓑ]	UJ371		(For Aluminum Drive Shaft)	UJ231C
	Brute Force Greaseable	UJ377		U-Joint (Front Axle Right Outer) [ⓐ]	UJ231
	Brute Force Non Greaseable	UJ371		(For Aluminum Drive Shaft)	UJ231C
	U-Joint (Front Axle Right Outer) [ⓐ]	UJ371			
	Brute Force Greaseable	UJ377			
	Brute Force Non Greaseable	UJ371			

(Continued)

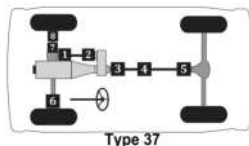

424 ▲ For Use w/ 1.063" Bearing Cap Application. ⓐ For Use w/ 1.188" Bearing Cap Application. ◇ For Use w/ Inner Lock Ring Application on Half Shaft. □ For Use w/ Outer Lock Ring Application on Half Shaft.

Passenger cars, light & medium trucks

(Cont.) -- Ford Truck 3/4 ton

MFG./YEAR	MODEL & LOCATION	PART NO.	MFG./YEAR	MODEL & LOCATION	PART NO.
Drive Shaft (4 W/D) (Cont.)			Drive Shaft (4 W/D) (Cont.)		
U-Joint (Cont.)			U-Joint (Cont.)		
1987	F-250 w/ 2 Joint Shaft & Outer Lock Ring Wheel Joints Exc. 5 Spd. Man. Trans.: [Type 36]		1987	F-250 w/ 2 Joint Shaft, 5 Spd. Man. Trans. & Outer Lock Ring Wheel Joints: [Type 36]	
	U-Joint (Frt. Shaft; Frt.) ①	UJ434		U-Joint (Frt. Shaft; Frt.) ①	UJ434
	<i>Brute Force Greaseable</i>	UJ265		<i>Brute Force Greaseable</i>	UJ265
	<i>Brute Force Non Greaseable</i>	UJ264		<i>Brute Force Non Greaseable</i>	UJ264
	U-Bolt Kit (Frt. Shaft; Frt.)	UJ534-10		U-Bolt Kit (Frt. Shaft; Frt.)	UJ534-10
	U-Joint (Frt. Shaft; Rr.) ②	UJ354		U-Joint (Frt. Shaft; Rr.) ②	UJ354
	<i>Brute Force Greaseable</i>	UJ270		<i>Brute Force Greaseable</i>	UJ270
	<i>Brute Force Non Greaseable</i>	UJ254		<i>Brute Force Non Greaseable</i>	UJ254
	(For Aluminum Drive Shaft)	UJ354C		(For Aluminum Drive Shaft)	UJ354C
	U-Joint (Rr. Shaft; Frt.) ③	UJ354		U-Joint (Rr. Shaft; Frt.) ③	UJ331
	<i>Brute Force Greaseable</i>	UJ270		<i>Brute Force Greaseable</i>	UJ232
	<i>Brute Force Non Greaseable</i>	UJ254		<i>Brute Force Non Greaseable</i>	UJ231
	(For Aluminum Drive Shaft)	UJ354C		(For Aluminum Drive Shaft)	UJ331C
	U-Joint (Rr. Shaft; Rr.) ④	UJ434		U-Joint (Rr. Shaft; Rr.) ④	UJ331-10
	<i>Brute Force Greaseable</i>	UJ265		<i>Brute Force Greaseable</i>	UJ331
	<i>Brute Force Non Greaseable</i>	UJ264		<i>Brute Force Non Greaseable</i>	UJ232
	U-Bolt Kit (Rr. Shaft; Rr.)	UJ534-10		<i>Brute Force Non Greaseable</i>	UJ231
	U-Joint (Front Axle Left Outer) ⑤	UJ231		(For Aluminum Drive Shaft)	UJ331C
	(For Aluminum Drive Shaft)	UJ231C		Clamp Kit (Rr. Shaft; Frt.)	UJ331-10
	U-Joint (Front Axle Right Inner) ⑥	UJ231		U-Joint (Rr. Shaft; Rr.) ④	UJ331
	(For Aluminum Drive Shaft)	UJ231C		<i>Brute Force Greaseable</i>	UJ232
	U-Joint (Front Axle Right Outer) ⑦	UJ231		<i>Brute Force Non Greaseable</i>	UJ231
	(For Aluminum Drive Shaft)	UJ231C		(For Aluminum Drive Shaft)	UJ331C
				U-Joint (Front Axle Left Outer) ⑤	UJ231
				(For Aluminum Drive Shaft)	UJ231C
				U-Joint (Front Axle Right Inner) ⑥	UJ231
				(For Aluminum Drive Shaft)	UJ231C
				U-Joint (Front Axle Right Outer) ⑦	UJ231
				(For Aluminum Drive Shaft)	UJ231C

(Continued)

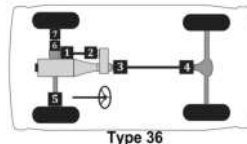

Type 36

Passenger cars, light & medium trucks

Ford Truck 3/4 ton -- (Cont.)

MFG./YEAR	MODEL & LOCATION	PART NO.	MFG./YEAR	MODEL & LOCATION	PART NO.
Drive Shaft (4 W/D) (Cont.)			Drive Shaft (4 W/D) (Cont.)		
U-Joint (Cont.)			U-Joint (Cont.)		
1986-1984 F-250 w/ 2 Joint Shaft & Inner Lock			1986-1984 F-250 w/ 2 Joint Shaft & Outer Lock		
Ring Wheel Joints: [Type 36]			Ring Wheel Joints: [Type 36]		
U-Joint (Frt. Shaft; Frt.) ^①		UJ434	U-Joint (Frt. Shaft; Frt.) ^①		UJ434
Brute Force Greaseable		UJ265	Brute Force Greaseable		UJ265
Brute Force Non Greaseable		UJ264	Brute Force Non Greaseable		UJ264
U-Bolt Kit (Frt. Shaft; Frt.)		UJ534-10	U-Bolt Kit (Frt. Shaft; Frt.)		UJ534-10
U-Joint (Frt. Shaft; Rr.) ^②		UJ434	U-Joint (Frt. Shaft; Rr.) ^②		UJ434
Brute Force Greaseable		UJ265	Brute Force Greaseable		UJ265
Brute Force Non Greaseable		UJ264	Brute Force Non Greaseable		UJ264
U-Bolt Kit (Frt. Shaft; Rr.)		UJ534-10	U-Bolt Kit (Frt. Shaft; Rr.)		UJ534-10
U-Joint (Rr. Shaft; Frt.) ^③		UJ354	U-Joint (Rr. Shaft; Frt.) ^③		UJ354
Brute Force Greaseable		UJ270	Brute Force Greaseable		UJ270
Brute Force Non Greaseable		UJ254	Brute Force Non Greaseable		UJ254
(For Aluminum Drive Shaft)		UJ354C	(For Aluminum Drive Shaft)		UJ354C
U-Joint (Rr. Shaft; Rr.) ^④		UJ434	U-Joint (Rr. Shaft; Rr.) ^④		UJ434
Brute Force Greaseable		UJ265	Brute Force Greaseable		UJ265
Brute Force Non Greaseable		UJ264	Brute Force Non Greaseable		UJ264
U-Bolt Kit (Rr. Shaft; Rr.)		UJ534-10	U-Bolt Kit (Rr. Shaft; Rr.)		UJ534-10
U-Joint (Front Axle Left Outer) ^⑤		UJ371	U-Joint (Front Axle Left Outer) ^⑤		UJ231
Brute Force Greaseable		UJ377	(For Aluminum Drive Shaft)		UJ231C
Brute Force Non Greaseable		UJ371	U-Joint (Front Axle Right Inner) ^⑥		UJ231
U-Joint (Front Axle Right Inner) ^⑥		UJ371	(For Aluminum Drive Shaft)		UJ231C
Brute Force Greaseable		UJ377	U-Joint (Front Axle Right Outer) ^⑦		UJ231
Brute Force Non Greaseable		UJ371	(For Aluminum Drive Shaft)		UJ231C
U-Joint (Front Axle Right Outer) ^⑦		UJ371			(Continued)
Brute Force Greaseable		UJ377			
Brute Force Non Greaseable		UJ371			

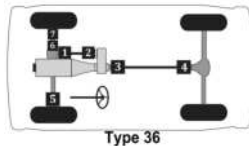

426 ▲ For Use w/ 1.063" Bearing Cap Application. ⊙ For Use w/ 1.188" Bearing Cap Application. ◇ For Use w/ Inner Lock Ring Application on Half Shaft. □ For Use w/ Outer Lock Ring Application on Half Shaft.

MFG./YEAR	MODEL & LOCATION	PART NO.	MFG./YEAR	MODEL & LOCATION	PART NO.
Drive Shaft (4 W/D) (Cont.)			Drive Shaft (4 W/D) (Cont.)		
U-Joint (Cont.)			U-Joint (Cont.)		
1986-1982 F-250 w/ 3 Joint Shaft & Inner Lock			1986-1982 F-250 w/ 3 Joint Shaft & Outer Lock		
Ring Wheel Joints: [Type 37]			Ring Wheel Joints: [Type 37]		
	U-Joint (Fr. Shaft; Fr.) ①	UJ434		U-Joint (Fr. Shaft; Fr.) ①	UJ434
	<i>Brute Force Greaseable</i>	UJ265		<i>Brute Force Greaseable</i>	UJ265
	<i>Brute Force Non Greaseable</i>	UJ264		<i>Brute Force Non Greaseable</i>	UJ264
	U-Bolt Kit (Fr. Shaft; Fr.)	UJ534-10		U-Bolt Kit (Fr. Shaft; Fr.)	UJ534-10
	U-Joint (Fr. Shaft; Rr.) ②	UJ434		U-Joint (Fr. Shaft; Rr.) ②	UJ434
	<i>Brute Force Greaseable</i>	UJ265		<i>Brute Force Greaseable</i>	UJ265
	<i>Brute Force Non Greaseable</i>	UJ264		<i>Brute Force Non Greaseable</i>	UJ264
	U-Bolt Kit (Fr. Shaft; Rr.)	UJ534-10		U-Bolt Kit (Fr. Shaft; Rr.)	UJ534-10
	U-Joint (Rr. Shaft; Fr.) ③	UJ434		U-Joint (Rr. Shaft; Fr.) ③	UJ434
	<i>Brute Force Greaseable</i>	UJ265		<i>Brute Force Greaseable</i>	UJ265
	<i>Brute Force Non Greaseable</i>	UJ264		<i>Brute Force Non Greaseable</i>	UJ264
	U-Bolt Kit (Rr. Shaft; Fr.)	UJ534-10		U-Bolt Kit (Rr. Shaft; Fr.)	UJ534-10
	U-Joint (Rr. Shaft; Ctr.) ④	UJ354		U-Joint (Rr. Shaft; Ctr.) ④	UJ354
	<i>Brute Force Greaseable</i>	UJ270		<i>Brute Force Greaseable</i>	UJ270
	<i>Brute Force Non Greaseable</i>	UJ254		<i>Brute Force Non Greaseable</i>	UJ254
	(For Aluminum Drive Shaft)	UJ354C		(For Aluminum Drive Shaft)	UJ354C
	U-Joint (Rr. Shaft; Rr.) ⑤	UJ434		U-Joint (Rr. Shaft; Rr.) ⑤	UJ434
	<i>Brute Force Greaseable</i>	UJ265		<i>Brute Force Greaseable</i>	UJ265
	<i>Brute Force Non Greaseable</i>	UJ264		<i>Brute Force Non Greaseable</i>	UJ264
	U-Bolt Kit (Rr. Shaft; Rr.)	UJ534-10		U-Bolt Kit (Rr. Shaft; Rr.)	UJ534-10
	U-Joint (Front Axle Left Outer) ⑥	UJ371		U-Joint (Front Axle Left Outer) ⑥	UJ231
	<i>Brute Force Greaseable</i>	UJ377		(For Aluminum Drive Shaft)	UJ231C
	<i>Brute Force Non Greaseable</i>	UJ371		U-Joint (Front Axle Right Inner) ⑦	UJ231
	U-Joint (Front Axle Right Inner) ⑦	UJ371		(For Aluminum Drive Shaft)	UJ231C
	<i>Brute Force Greaseable</i>	UJ377		U-Joint (Front Axle Right Outer) ⑧	UJ231
	<i>Brute Force Non Greaseable</i>	UJ371		(For Aluminum Drive Shaft)	UJ231C
	U-Joint (Front Axle Right Outer) ⑧	UJ371			
	<i>Brute Force Greaseable</i>	UJ377			
	<i>Brute Force Non Greaseable</i>	UJ371			

(Continued)

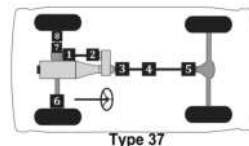

Passenger cars, light & medium trucks

Ford Truck 3/4 ton -- (Cont.)

MFG./YEAR	MODEL & LOCATION	PART NO.	MFG./YEAR	MODEL & LOCATION	PART NO.
Drive Shaft (4 W/D) (Cont.)			Drive Shaft (4 W/D) (Cont.)		
U-Joint (Cont.)			U-Joint (Cont.)		
1983-1982 F-250 w/ 2 Joint Shaft & Inner Lock			1983-1982 F-250 w/ 2 Joint Shaft & Outer Lock		
Ring Wheel Joints: [Type 36]			Ring Wheel Joints: [Type 36]		
U-Joint (Fr. Shaft; Fr.) ^①		UJ434	U-Joint (Fr. Shaft; Fr.) ^①		UJ434
Brute Force Greaseable		UJ265	Brute Force Greaseable		UJ265
Brute Force Non Greaseable		UJ264	Brute Force Non Greaseable		UJ264
U-Bolt Kit (Fr. Shaft; Fr.)		UJ534-10	U-Bolt Kit (Fr. Shaft; Fr.)		UJ534-10
U-Joint (Fr. Shaft; Rr.) ^②		UJ434	U-Joint (Fr. Shaft; Rr.) ^②		UJ434
Brute Force Greaseable		UJ265	Brute Force Greaseable		UJ265
Brute Force Non Greaseable		UJ264	Brute Force Non Greaseable		UJ264
U-Bolt Kit (Fr. Shaft; Rr.)		UJ534-10	U-Bolt Kit (Fr. Shaft; Rr.)		UJ534-10
U-Joint (Rr. Shaft; Fr.) ^③		UJ434	U-Joint (Rr. Shaft; Fr.) ^③		UJ434
Brute Force Greaseable		UJ265	Brute Force Greaseable		UJ265
Brute Force Non Greaseable		UJ264	Brute Force Non Greaseable		UJ264
U-Bolt Kit (Rr. Shaft; Fr.)		UJ534-10	U-Bolt Kit (Rr. Shaft; Fr.)		UJ534-10
U-Joint (Rr. Shaft; Rr.) ^④		UJ434	U-Joint (Rr. Shaft; Rr.) ^④		UJ434
Brute Force Greaseable		UJ265	Brute Force Greaseable		UJ265
Brute Force Non Greaseable		UJ264	Brute Force Non Greaseable		UJ264
U-Bolt Kit (Rr. Shaft; Rr.)		UJ534-10	U-Bolt Kit (Rr. Shaft; Rr.)		UJ534-10
U-Joint (Front Axle Left Outer) ^⑤		UJ371	U-Joint (Front Axle Left Outer) ^⑤		UJ231
Brute Force Greaseable		UJ377	(For Aluminum Drive Shaft)		UJ231C
Brute Force Non Greaseable		UJ371	U-Joint (Front Axle Right Inner) ^⑥		UJ231
U-Joint (Front Axle Right Inner) ^⑥		UJ371	(For Aluminum Drive Shaft)		UJ231C
Brute Force Greaseable		UJ377	U-Joint (Front Axle Right Outer) ^⑦		UJ231
Brute Force Non Greaseable		UJ371	(For Aluminum Drive Shaft)		UJ231C
U-Joint (Front Axle Right Outer) ^⑦		UJ371			(Continued)
Brute Force Greaseable		UJ377			
Brute Force Non Greaseable		UJ371			

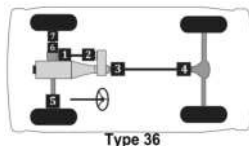

428 ▲ For Use w/ 1.063" Bearing Cap Application. Ⓞ For Use w/ 1.188" Bearing Cap Application. ◇ For Use w/ Inner Lock Ring Application on Half Shaft. □ For Use w/ Outer Lock Ring Application on Half Shaft.

MFG./YEAR	MODEL & LOCATION	PART NO.	MFG./YEAR	MODEL & LOCATION	PART NO.
Drive Shaft (4 W/D) (Cont.)			Drive Shaft (4 W/D) (Cont.)		
U-Joint (Cont.)			U-Joint (Cont.)		
1981-1980 F-250 w/ 2 Joint Shaft & Inner Lock			1981-1980 F-250 w/ 3 Joint Shaft & Inner Lock		
Ring Wheel Joints: [Type 36]			Ring Wheel Joints: [Type 37]		
U-Joint (Fr. Shaft; Fr.) ^①		• UJ434	U-Joint (Fr. Shaft; Fr.) ^①		• UJ434
Brute Force Greaseable		UJ265	Brute Force Greaseable		UJ265
Brute Force Non Greaseable		UJ264	Brute Force Non Greaseable		UJ264
U-Bolt Kit (Fr. Shaft; Fr.)		UJ534-10	U-Bolt Kit (Fr. Shaft; Fr.)		UJ534-10
U-Joint (Fr. Shaft; Fr.) ^①		■ UJ354	U-Joint (Fr. Shaft; Fr.) ^①		■ UJ354
Brute Force Greaseable		UJ270	Brute Force Greaseable		UJ270
Brute Force Non Greaseable		UJ254	Brute Force Non Greaseable		UJ254
(For Aluminum Drive Shaft)		UJ354C	(For Aluminum Drive Shaft)		UJ354C
U-Joint (Fr. Shaft; Rr.) ^②		• UJ434	U-Joint (Fr. Shaft; Rr.) ^②		• UJ434
Brute Force Greaseable		UJ265	Brute Force Greaseable		UJ265
Brute Force Non Greaseable		UJ264	Brute Force Non Greaseable		UJ264
U-Bolt Kit (Fr. Shaft; Rr.)		UJ534-10	U-Bolt Kit (Fr. Shaft; Rr.)		UJ534-10
U-Joint (Fr. Shaft; Rr.) ^②		■ UJ354	U-Joint (Fr. Shaft; Rr.) ^②		■ UJ354
Brute Force Greaseable		UJ270	Brute Force Greaseable		UJ270
Brute Force Non Greaseable		UJ254	Brute Force Non Greaseable		UJ254
(For Aluminum Drive Shaft)		UJ354C	(For Aluminum Drive Shaft)		UJ354C
U-Joint (Rr. Shaft; Fr.) ^③		UJ354	U-Joint (Rr. Shaft; Fr.) ^③		UJ354
Brute Force Greaseable		UJ270	Brute Force Greaseable		UJ270
Brute Force Non Greaseable		UJ254	Brute Force Non Greaseable		UJ254
(For Aluminum Drive Shaft)		UJ354C	(For Aluminum Drive Shaft)		UJ354C
U-Joint (Rr. Shaft; Rr.) ^④		UJ434	U-Joint (Rr. Shaft; Rr.) ^④		UJ434
Brute Force Greaseable		UJ265	Brute Force Greaseable		UJ265
Brute Force Non Greaseable		UJ264	Brute Force Non Greaseable		UJ264
U-Bolt Kit (Rr. Shaft; Rr.)		UJ534-10	U-Bolt Kit (Rr. Shaft; Rr.)		UJ534-10
U-Joint (Front Axle Left Outer) ^⑤		UJ371	U-Joint (Rr. Shaft; Rr.) ^⑤		UJ434
Brute Force Greaseable		UJ377	Brute Force Greaseable		UJ265
Brute Force Non Greaseable		UJ371	Brute Force Non Greaseable		UJ264
U-Joint (Front Axle Right Inner) ^⑥		UJ371	U-Bolt Kit (Rr. Shaft; Rr.)		UJ534-10
Brute Force Greaseable		UJ377	U-Joint (Front Axle Left Outer) ^⑥		UJ371
Brute Force Non Greaseable		UJ371	Brute Force Greaseable		UJ377
U-Joint (Front Axle Right Outer) ^⑦		UJ371	Brute Force Non Greaseable		UJ371
Brute Force Greaseable		UJ377	U-Joint (Front Axle Right Inner) ^⑦		UJ371
Brute Force Non Greaseable		UJ371	Brute Force Greaseable		UJ377
			Brute Force Non Greaseable		UJ371
			U-Joint (Front Axle Right Outer) ^⑧		UJ371
			Brute Force Greaseable		UJ377
			Brute Force Non Greaseable		UJ371

(Continued)

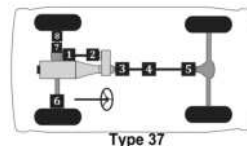
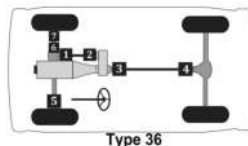

Passenger cars, light & medium trucks

Ford Truck 3/4 ton -- (Cont.)

MFG./YEAR	MODEL & LOCATION	PART NO.	MFG./YEAR	MODEL & LOCATION	PART NO.
Drive Shaft (4 W/D) (Cont.)			Drive Shaft (4 W/D) (Cont.)		
U-Joint (Cont.)			U-Joint (Cont.)		
1981-1980 F-250 w/ 3 Joint Shaft & Outer Lock			1981-1980 F-250 w/ 2 Joint Shaft & Outer Lock		
Ring Wheel Joints: [Type 37]			Ring Wheel Joints: [Type 36]		
U-Joint (Fr. Shaft; Frt.)⊙		• UJ434	U-Joint (Fr. Shaft; Frt.)⊙		• UJ434
Brute Force Greaseable		UJ265	Brute Force Greaseable		UJ265
Brute Force Non Greaseable		UJ264	Brute Force Non Greaseable		UJ264
U-Bolt Kit (Fr. Shaft; Frt.)		UJ534-10	U-Bolt Kit (Fr. Shaft; Frt.)		UJ534-10
U-Joint (Fr. Shaft; Rr.)⊙		■ UJ354	U-Joint (Fr. Shaft; Rr.)⊙		■ UJ354
Brute Force Greaseable		UJ270	Brute Force Greaseable		UJ270
Brute Force Non Greaseable		UJ254	Brute Force Non Greaseable		UJ254
(For Aluminum Drive Shaft)		UJ354C	(For Aluminum Drive Shaft)		UJ354C
U-Joint (Fr. Shaft; Rr.)⊙		• UJ434	U-Joint (Fr. Shaft; Rr.)⊙		• UJ434
Brute Force Greaseable		UJ265	Brute Force Greaseable		UJ265
Brute Force Non Greaseable		UJ264	Brute Force Non Greaseable		UJ264
U-Bolt Kit (Fr. Shaft; Rr.)		UJ534-10	U-Bolt Kit (Fr. Shaft; Rr.)		UJ534-10
U-Joint (Fr. Shaft; Rr.)⊙		■ UJ354	U-Joint (Fr. Shaft; Rr.)⊙		■ UJ354
Brute Force Greaseable		UJ270	Brute Force Greaseable		UJ270
Brute Force Non Greaseable		UJ254	Brute Force Non Greaseable		UJ254
(For Aluminum Drive Shaft)		UJ354C	(For Aluminum Drive Shaft)		UJ354C
U-Joint (Rr. Shaft; Frt.)⊙		UJ354	U-Joint (Rr. Shaft; Frt.)⊙		UJ354
Brute Force Greaseable		UJ270	Brute Force Greaseable		UJ270
Brute Force Non Greaseable		UJ254	Brute Force Non Greaseable		UJ254
(For Aluminum Drive Shaft)		UJ354C	(For Aluminum Drive Shaft)		UJ354C
U-Joint (Rr. Shaft; Ctr.)⊙		UJ354	U-Joint (Rr. Shaft; Rr.)⊙		UJ434
Brute Force Greaseable		UJ270	Brute Force Greaseable		UJ265
Brute Force Non Greaseable		UJ254	Brute Force Non Greaseable		UJ264
(For Aluminum Drive Shaft)		UJ354C	U-Bolt Kit (Rr. Shaft; Rr.)		UJ534-10
U-Joint (Rr. Shaft; Rr.)⊙		UJ434	U-Joint (Front Axle Left Outer)⊙		UJ231
Brute Force Greaseable		UJ265	(For Aluminum Drive Shaft)		UJ231C
Brute Force Non Greaseable		UJ264	U-Joint (Front Axle Right Inner)⊙		UJ231
U-Bolt Kit (Rr. Shaft; Rr.)		UJ534-10	(For Aluminum Drive Shaft)		UJ231C
U-Joint (Front Axle Left Outer)⊙		UJ231	U-Joint (Front Axle Right Outer)⊙		UJ231
(For Aluminum Drive Shaft)		UJ231C	(For Aluminum Drive Shaft)		UJ231C
U-Joint (Front Axle Right Inner)⊙		UJ231			(Continued)
(For Aluminum Drive Shaft)		UJ231C			
U-Joint (Front Axle Right Outer)⊙		UJ231			
(For Aluminum Drive Shaft)		UJ231C			

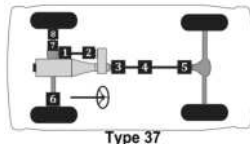
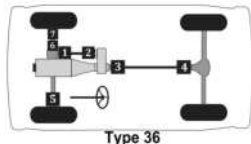

430 ▲ For Use w/ 1.063" Bearing Cap Application. ⊙ For Use w/ 1.188" Bearing Cap Application. ◇ For Use w/ Inner Lock Ring Application on Half Shaft. □ For Use w/ Outer Lock Ring Application on Half Shaft.

Passenger cars, light & medium trucks

(Cont.) -- Ford Truck 3/4 ton

MFG./YEAR	MODEL & LOCATION	PART NO.	MFG./YEAR	MODEL & LOCATION	PART NO.
Drive Shaft (4 W/D) (Cont.)			Drive Shaft (4 W/D) (Cont.)		
U-Joint (Cont.)			U-Joint (Cont.)		
1979	F-250 w/ 2 Joint Shaft & 1.188" O.D.		1979	F-250 w/ 3 Joint Shaft & 1.188" O.D.	
	Brg. Cap Wheel Joints: [Type 26]			Brg. Cap Wheel Joints: [Type 27]	
	U-Joint (Frt. Shaft; Frt.)①	UJ434		U-Joint (Frt. Shaft; Frt.)①	UJ434
	Brute Force Greaseable	UJ265		Brute Force Greaseable	UJ265
	Brute Force Non Greaseable	UJ264		Brute Force Non Greaseable	UJ264
	U-Bolt Kit (Frt. Shaft; Frt.)	UJ534-10		U-Bolt Kit (Frt. Shaft; Frt.)	UJ534-10
	U-Joint (Frt. Shaft; Rr.)②	[2] UJ354		U-Joint (Frt. Shaft; Rr.)②	[2] UJ354
	Brute Force Greaseable	UJ270		Brute Force Greaseable	UJ270
	Brute Force Non Greaseable	UJ254		Brute Force Non Greaseable	UJ254
	(For Aluminum Drive Shaft)	UJ354C		(For Aluminum Drive Shaft)	UJ354C
	U-Joint (Rr. Shaft; Frt.)③	UJ354		U-Joint (Rr. Shaft; Frt.)③	UJ354
	Brute Force Greaseable	UJ270		Brute Force Greaseable	UJ270
	Brute Force Non Greaseable	UJ254		Brute Force Non Greaseable	UJ254
	(For Aluminum Drive Shaft)	UJ354C		(For Aluminum Drive Shaft)	UJ354C
	U-Joint (Rr. Shaft; Rr.)④	UJ434		U-Joint (Rr. Shaft; Rr.)④	UJ354
	Brute Force Greaseable	UJ265		Brute Force Greaseable	UJ270
	Brute Force Non Greaseable	UJ264		Brute Force Non Greaseable	UJ254
	U-Bolt Kit (Rr. Shaft; Rr.)	UJ534-10		U-Bolt Kit (Rr. Shaft; Rr.)	UJ354C
	U-Joint (Wheel Joint)⑤	[2] UJ371		U-Joint (Rr. Shaft; Rr.)⑤	UJ434
	Brute Force Greaseable	UJ377		Brute Force Greaseable	UJ265
	Brute Force Non Greaseable	UJ371		Brute Force Non Greaseable	UJ264
	Centering Yoke	UJ608		U-Bolt Kit (Rr. Shaft; Rr.)	UJ534-10
	Weld Yoke	UJ638		U-Joint (Wheel Joint)⑥	[2] UJ371
	H Yoke	UJ648		Brute Force Greaseable	UJ377
				Brute Force Non Greaseable	UJ371
				Centering Yoke	UJ608
				Weld Yoke	UJ638
				H Yoke	UJ648

(Continued)

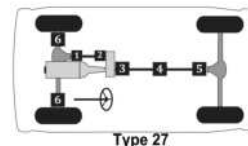
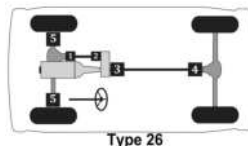

Passenger cars, light & medium trucks

Ford Truck 3/4 ton -- (Cont.)

MFG./YEAR	MODEL & LOCATION	PART NO.	MFG./YEAR	MODEL & LOCATION	PART NO.
Drive Shaft (4 W/D) (Cont.)			Drive Shaft (4 W/D) (Cont.)		
U-Joint (Cont.)			U-Joint (Cont.)		
1979	F-250 w/ 2 Joint Shaft & 1.375" O.D. Brg. Cap Wheel Joints: [Type 26]		1978	F-250 w/ 3.5" Intm. Shaft Yoke & 1.188" O.D. Brg. Cap Wheel Joints: [Type 34]	
U-Joint (Fr. Shaft; Fr.) [⊙]		UJ434	U-Joint (Fr. Shaft; Fr.) [⊙]		UJ354
Brute Force Greaseable		UJ265	Brute Force Greaseable		UJ270
Brute Force Non Greaseable		UJ264	Brute Force Non Greaseable		UJ254
U-Bolt Kit (Fr. Shaft; Fr.)		UJ534-10	(For Aluminum Drive Shaft)		UJ354C
U-Joint (Fr. Shaft; Rr.) [⊙]	[2]	UJ354	U-Joint (Fr. Shaft; Rr.) [⊙]	[2]	UJ379
Brute Force Greaseable		UJ270	Brute Force Greaseable		UJ280
Brute Force Non Greaseable		UJ254	Brute Force Non Greaseable		UJ269
(For Aluminum Drive Shaft)		UJ354C	U-Joint (Intmd. Shaft; Fr.) [⊙]		UJ369
U-Joint (Rr. Shaft; Fr.) [⊙]		UJ354	Brute Force Greaseable		UJ280
Brute Force Greaseable		UJ270	Brute Force Non Greaseable		UJ269
Brute Force Non Greaseable		UJ254	(For Aluminum Drive Shaft)		UJ369C
(For Aluminum Drive Shaft)		UJ354C	U-Joint (Intmd. Shaft; Rr.) [⊙]		UJ369
U-Joint (Rr. Shaft; Rr.) [⊙]		UJ434	Brute Force Greaseable		UJ280
Brute Force Greaseable		UJ265	Brute Force Non Greaseable		UJ269
Brute Force Non Greaseable		UJ264	(For Aluminum Drive Shaft)		UJ369C
U-Bolt Kit (Rr. Shaft; Rr.)		UJ534-10	U-Joint (Rr. Shaft; Fr.) [⊙]		UJ354
U-Joint (Wheel Joint) [⊙]	[2]	UJ374	Brute Force Greaseable		UJ270
Brute Force Non Greaseable		UJ374BF	Brute Force Non Greaseable		UJ254
Centering Yoke		UJ608	(For Aluminum Drive Shaft)		UJ354C
Weld Yoke		UJ638	U-Joint (Rr. Shaft; Rr.) [⊙]		UJ354
H Yoke		UJ648	Brute Force Greaseable		UJ270
1979	F-250 w/ 3 Joint Shaft & 1.375" O.D. Brg. Cap Wheel Joints: [Type 27]		Brute Force Non Greaseable		UJ254
U-Joint (Fr. Shaft; Fr.) [⊙]		UJ434	(For Aluminum Drive Shaft)		UJ354C
Brute Force Greaseable		UJ265	U-Joint (Wheel Joint) [⊙]	[2]	UJ371
Brute Force Non Greaseable		UJ264	Brute Force Greaseable		UJ377
U-Bolt Kit (Fr. Shaft; Fr.)		UJ534-10	Brute Force Non Greaseable		UJ371
U-Joint (Fr. Shaft; Rr.) [⊙]	[2]	UJ354	Centering Yoke		UJ607
Brute Force Greaseable		UJ270	H Yoke		UJ647
Brute Force Non Greaseable		UJ254			(Continued)
(For Aluminum Drive Shaft)		UJ354C			
U-Joint (Rr. Shaft; Fr.) [⊙]		UJ354			
Brute Force Greaseable		UJ270			
Brute Force Non Greaseable		UJ254			
(For Aluminum Drive Shaft)		UJ354C			
U-Joint (Rr. Shaft; Ctr.) [⊙]		UJ354			
Brute Force Greaseable		UJ270			
Brute Force Non Greaseable		UJ254			
(For Aluminum Drive Shaft)		UJ354C			
U-Joint (Rr. Shaft; Rr.) [⊙]		UJ434			
Brute Force Greaseable		UJ265			
Brute Force Non Greaseable		UJ264			
U-Bolt Kit (Rr. Shaft; Rr.)		UJ534-10			
U-Joint (Wheel Joint) [⊙]	[2]	UJ374			
Brute Force Non Greaseable		UJ374BF			
Centering Yoke		UJ608			
Weld Yoke		UJ638			
H Yoke		UJ648			

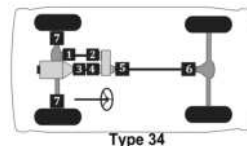
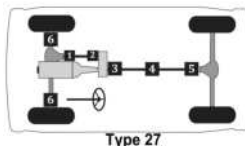
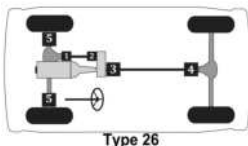

Passenger cars, light & medium trucks

(Cont.) -- Ford Truck 3/4 ton

MFG./YEAR	MODEL & LOCATION	PART NO.	MFG./YEAR	MODEL & LOCATION	PART NO.
Drive Shaft (4 W/D) (Cont.)			Drive Shaft (4 W/D) (Cont.)		
U-Joint (Cont.)			U-Joint (Cont.)		
1978	F-250 w/ 3.5" Intm. Shaft Yoke & 1.375" O.D. Brg. Cap Wheel Joints:		1978	F-250 w/ 3.875" Intm. Shaft Yoke & 1.188" O.D. Brg. Cap Wheel Joints:	
	[Type 34]			[Type 34]	
	U-Joint (Frnt. Shaft; Frnt.) ①	UJ354		U-Joint (Frnt. Shaft; Frnt.) ①	UJ354
	<i>Brute Force Greaseable</i>	UJ270		<i>Brute Force Greaseable</i>	UJ270
	<i>Brute Force Non Greaseable</i>	UJ254		<i>Brute Force Non Greaseable</i>	UJ254
	(For Aluminum Drive Shaft)	UJ354C		(For Aluminum Drive Shaft)	UJ354C
	U-Joint (Frnt. Shaft; Rr.) ②	[2] UJ379		U-Joint (Frnt. Shaft; Rr.) ②	[2] UJ379
	<i>Brute Force Greaseable</i>	UJ280		<i>Brute Force Greaseable</i>	UJ280
	<i>Brute Force Non Greaseable</i>	UJ269		<i>Brute Force Non Greaseable</i>	UJ269
	U-Joint (Intmd. Shaft; Frnt.) ③	UJ354		U-Joint (Intmd. Shaft; Frnt.) ③	UJ354
	<i>Brute Force Greaseable</i>	UJ270		<i>Brute Force Greaseable</i>	UJ270
	<i>Brute Force Non Greaseable</i>	UJ254		<i>Brute Force Non Greaseable</i>	UJ254
	(For Aluminum Drive Shaft)	UJ354C		(For Aluminum Drive Shaft)	UJ354C
	U-Joint (Intmd. Shaft; Rr.) ④	UJ354		U-Joint (Intmd. Shaft; Rr.) ④	UJ354
	<i>Brute Force Greaseable</i>	UJ270		<i>Brute Force Greaseable</i>	UJ270
	<i>Brute Force Non Greaseable</i>	UJ254		<i>Brute Force Non Greaseable</i>	UJ254
	(For Aluminum Drive Shaft)	UJ354C		(For Aluminum Drive Shaft)	UJ354C
	U-Joint (Rr. Shaft; Frnt.) ⑤	UJ354		U-Joint (Rr. Shaft; Frnt.) ⑤	UJ354
	<i>Brute Force Greaseable</i>	UJ270		<i>Brute Force Greaseable</i>	UJ270
	<i>Brute Force Non Greaseable</i>	UJ254		<i>Brute Force Non Greaseable</i>	UJ254
	(For Aluminum Drive Shaft)	UJ354C		(For Aluminum Drive Shaft)	UJ354C
	U-Joint (Rr. Shaft; Rr.) ⑥	UJ354		U-Joint (Rr. Shaft; Rr.) ⑥	UJ354
	<i>Brute Force Greaseable</i>	UJ270		<i>Brute Force Greaseable</i>	UJ270
	<i>Brute Force Non Greaseable</i>	UJ254		<i>Brute Force Non Greaseable</i>	UJ254
	(For Aluminum Drive Shaft)	UJ354C		(For Aluminum Drive Shaft)	UJ354C
	U-Joint (Wheel Joint) ⑦	[2] UJ374		U-Joint (Wheel Joint) ⑦	[2] UJ371
	<i>Brute Force Non Greaseable</i>	UJ374BF		<i>Brute Force Greaseable</i>	UJ377
	Centering Yoke	UJ607		<i>Brute Force Non Greaseable</i>	UJ371
	H Yoke	UJ647		Centering Yoke	UJ607
				H Yoke	UJ647

(Continued)

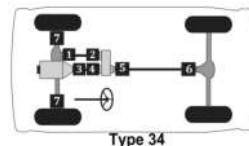

Passenger cars, light & medium trucks

Ford Truck 3/4 ton -- (Cont.)

MFG./YEAR	MODEL & LOCATION	PART NO.	MFG./YEAR	MODEL & LOCATION	PART NO.
Drive Shaft (4 W/D) (Cont.)			Drive Shaft (4 W/D) (Cont.)		
U-Joint (Cont.)			U-Joint (Cont.)		
1978	F-250 w/ 3.875" Intm. Shaft Yoke & 1.375" O.D. Brg. Cap Wheel Joints: [Type 34]		1977	F-250 w/ 3.5" Intm. Shaft Yoke, Full Time Transfer Case & Outer Lock Ring Wheel Joints: [Type 39]	
	U-Joint (Frnt. Shaft; Frnt.) Ⓐ	UJ354		U-Joint (Frnt. Shaft; Frnt.) Ⓐ	UJ369
	<i>Brute Force Greaseable</i>	UJ270		<i>Brute Force Greaseable</i>	UJ280
	<i>Brute Force Non Greaseable</i>	UJ254		<i>Brute Force Non Greaseable</i>	UJ269
	(For Aluminum Drive Shaft)	UJ354C		(For Aluminum Drive Shaft)	UJ369C
	U-Joint (Frnt. Shaft; Rr.) Ⓑ	[2] UJ379		U-Joint (Frnt. Shaft; Rr.) Ⓑ	[2] UJ379
	<i>Brute Force Greaseable</i>	UJ280		<i>Brute Force Greaseable</i>	UJ280
	<i>Brute Force Non Greaseable</i>	UJ269		<i>Brute Force Non Greaseable</i>	UJ269
	U-Joint (Intmd. Shaft; Frnt.) Ⓒ	UJ369		U-Joint (Intmd. Shaft; Frnt.) Ⓒ	UJ353
	<i>Brute Force Greaseable</i>	UJ280		<i>Brute Force Greaseable</i>	UJ275
	<i>Brute Force Non Greaseable</i>	UJ269		<i>Brute Force Non Greaseable</i>	UJ269
	(For Aluminum Drive Shaft)	UJ369C		(For Aluminum Drive Shaft)	UJ369C
	U-Joint (Intmd. Shaft; Rr.) Ⓓ	UJ369		U-Joint (Intmd. Shaft; Rr.) Ⓓ	UJ353
	<i>Brute Force Greaseable</i>	UJ280		<i>Brute Force Greaseable</i>	UJ275
	<i>Brute Force Non Greaseable</i>	UJ269		<i>Brute Force Non Greaseable</i>	UJ269
	(For Aluminum Drive Shaft)	UJ369C		(For Aluminum Drive Shaft)	UJ369C
	U-Joint (Rr. Shaft; Frnt.) Ⓔ	UJ354		U-Joint (Rr. Shaft; Frnt.) Ⓔ	UJ369
	<i>Brute Force Greaseable</i>	UJ270		<i>Brute Force Greaseable</i>	UJ280
	<i>Brute Force Non Greaseable</i>	UJ254		<i>Brute Force Non Greaseable</i>	UJ269
	(For Aluminum Drive Shaft)	UJ354C		(For Aluminum Drive Shaft)	UJ369C
	U-Joint (Rr. Shaft; Rr.) Ⓚ	UJ354		U-Joint (Rr. Shaft; Rr.) Ⓚ	UJ369
	<i>Brute Force Greaseable</i>	UJ270		<i>Brute Force Greaseable</i>	UJ280
	<i>Brute Force Non Greaseable</i>	UJ254		<i>Brute Force Non Greaseable</i>	UJ269
	(For Aluminum Drive Shaft)	UJ354C		(For Aluminum Drive Shaft)	UJ369C
	U-Joint (Wheel Joint) Ⓛ	[2] UJ374		U-Joint (Front Axle Left Outer) Ⓛ	UJ231
	<i>Brute Force Non Greaseable</i>	UJ374BF		(For Aluminum Drive Shaft)	UJ231C
	Centering Yoke	UJ607		U-Joint (Front Axle Right Inner) Ⓜ	UJ231
	H Yoke	UJ647		(For Aluminum Drive Shaft)	UJ231C
				Centering Yoke	UJ607
				U-Joint (Front Axle Right Outer) Ⓨ	UJ231
				(For Aluminum Drive Shaft)	UJ231C
				H Yoke	UJ647
					(Continued)

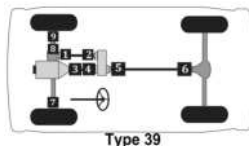
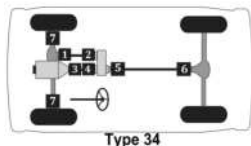

434 ▲ For Use w/ 1.063" Bearing Cap Application. Ⓐ For Use w/ 1.188" Bearing Cap Application. ◇ For Use w/ Inner Lock Ring Application on Half Shaft. □ For Use w/ Outer Lock Ring Application on Half Shaft.

Passenger cars, light & medium trucks

(Cont.) -- Ford Truck 3/4 ton

MFG./YEAR	MODEL & LOCATION	PART NO.	MFG./YEAR	MODEL & LOCATION	PART NO.
Drive Shaft (4 W/D) (Cont.)			Drive Shaft (4 W/D) (Cont.)		
U-Joint (Cont.)			U-Joint (Cont.)		
1977	F-250 w/ 3.5" Intm. Shaft Yoke, Part Time Transfer Case & Outer Lock Ring Wheel Joints: [Type 39]		1977	F-250 w/ 3.875" Intm. Shaft Yoke, Full Time Transfer Case & Outer Lock Ring Wheel Joints: [Type 39]	
	U-Joint (Frnt. Shaft; Frt.) ①	UJ353		U-Joint (Frnt. Shaft; Frt.) ①	UJ369
	<i>Brute Force Greaseable</i>	UJ275		<i>Brute Force Greaseable</i>	UJ280
	U-Joint (Frnt. Shaft; Rr.) ②	UJ353		<i>Brute Force Non Greaseable</i>	UJ269
	<i>Brute Force Greaseable</i>	UJ275		(For Aluminum Drive Shaft)	UJ369C
	U-Joint (Intmd. Shaft; Frt.) ③	UJ353		U-Joint (Frnt. Shaft; Rr.) ②	[2] UJ379
	<i>Brute Force Greaseable</i>	UJ275		<i>Brute Force Greaseable</i>	UJ280
	U-Joint (Intmd. Shaft; Rr.) ④	UJ353		<i>Brute Force Non Greaseable</i>	UJ269
	<i>Brute Force Greaseable</i>	UJ275		U-Joint (Intmd. Shaft; Frt.) ⑤	UJ354
	U-Joint (Rr. Shaft; Frt.) ⑥	UJ354		<i>Brute Force Greaseable</i>	UJ270
	<i>Brute Force Greaseable</i>	UJ270		<i>Brute Force Non Greaseable</i>	UJ254
	<i>Brute Force Non Greaseable</i>	UJ254		(For Aluminum Drive Shaft)	UJ354C
	(For Aluminum Drive Shaft)	UJ354C		U-Joint (Intmd. Shaft; Rr.) ④	UJ354
	U-Joint (Rr. Shaft; Rr.) ⑥	UJ354		<i>Brute Force Greaseable</i>	UJ270
	<i>Brute Force Greaseable</i>	UJ270		<i>Brute Force Non Greaseable</i>	UJ254
	<i>Brute Force Non Greaseable</i>	UJ254		(For Aluminum Drive Shaft)	UJ354C
	(For Aluminum Drive Shaft)	UJ354C		U-Joint (Rr. Shaft; Frt.) ⑤	[2] UJ379
	U-Joint (Front Axle Left Outer) ⑦	UJ231		<i>Brute Force Greaseable</i>	UJ280
	(For Aluminum Drive Shaft)	UJ231C		<i>Brute Force Non Greaseable</i>	UJ269
	U-Joint (Front Axle Right Inner) ⑧	UJ231		U-Joint (Rr. Shaft; Rr.) ⑥	UJ369
	(For Aluminum Drive Shaft)	UJ231C		<i>Brute Force Greaseable</i>	UJ280
	U-Joint (Front Axle Right Outer) ⑧	UJ231		<i>Brute Force Non Greaseable</i>	UJ269
	(For Aluminum Drive Shaft)	UJ231C		(For Aluminum Drive Shaft)	UJ369C
	H Yoke	UJ647		U-Joint (Front Axle Left Outer) ⑦	UJ231
				(For Aluminum Drive Shaft)	UJ231C
				U-Joint (Front Axle Right Inner) ⑧	UJ231
				(For Aluminum Drive Shaft)	UJ231C
				Centering Yoke	UJ607
				U-Joint (Front Axle Right Outer) ⑧	UJ231
				(For Aluminum Drive Shaft)	UJ231C
				H Yoke	UJ647

(Continued)

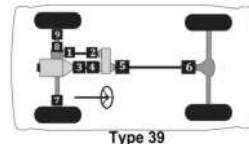

Passenger cars, light & medium trucks

Ford Truck 3/4 ton -- (Cont.)

MFG./YEAR	MODEL & LOCATION	PART NO.	MFG./YEAR	MODEL & LOCATION	PART NO.
Drive Shaft (4 W/D) (Cont.)			Drive Shaft (4 W/D) (Cont.)		
U-Joint (Cont.)			U-Joint (Cont.)		
1977	F-250 w/ 3.875" Intm. Shaft Yoke, Part Time Transfer Case & Outer Lock Ring Wheel Joints: [Type 39]		1977	F-250 w/ 3.875" Intm. Shaft Yoke, Part Time Transfer Case & Inner Lock Ring Wheel Joints: [Type 39]	
	U-Joint (Fr. Shaft; Frt.) Ⓐ	UJ353		U-Joint (Fr. Shaft; Frt.) Ⓐ	UJ353
	<i>Brute Force Greaseable</i>	UJ275		<i>Brute Force Greaseable</i>	UJ275
	U-Joint (Fr. Shaft; Rr.) Ⓑ	UJ353		U-Joint (Fr. Shaft; Rr.) Ⓑ	UJ353
	<i>Brute Force Greaseable</i>	UJ275		<i>Brute Force Greaseable</i>	UJ275
	U-Joint (Intmd. Shaft; Frt.) Ⓒ	UJ354		U-Joint (Intmd. Shaft; Frt.) Ⓒ	UJ354
	<i>Brute Force Greaseable</i>	UJ270		<i>Brute Force Greaseable</i>	UJ270
	<i>Brute Force Non Greaseable</i>	UJ254		<i>Brute Force Non Greaseable</i>	UJ254
	(For Aluminum Drive Shaft)	UJ354C		(For Aluminum Drive Shaft)	UJ354C
	U-Joint (Intmd. Shaft; Rr.) Ⓓ	UJ354		U-Joint (Intmd. Shaft; Rr.) Ⓓ	UJ354
	<i>Brute Force Greaseable</i>	UJ270		<i>Brute Force Greaseable</i>	UJ270
	<i>Brute Force Non Greaseable</i>	UJ254		<i>Brute Force Non Greaseable</i>	UJ254
	(For Aluminum Drive Shaft)	UJ354C		(For Aluminum Drive Shaft)	UJ354C
	U-Joint (Rr. Shaft; Frt.) Ⓔ	UJ354		U-Joint (Rr. Shaft; Frt.) Ⓔ	UJ354
	<i>Brute Force Greaseable</i>	UJ270		<i>Brute Force Greaseable</i>	UJ270
	<i>Brute Force Non Greaseable</i>	UJ254		<i>Brute Force Non Greaseable</i>	UJ254
	(For Aluminum Drive Shaft)	UJ354C		(For Aluminum Drive Shaft)	UJ354C
	U-Joint (Rr. Shaft; Rr.) Ⓕ	UJ354		U-Joint (Rr. Shaft; Rr.) Ⓕ	UJ354
	<i>Brute Force Greaseable</i>	UJ270		<i>Brute Force Greaseable</i>	UJ270
	<i>Brute Force Non Greaseable</i>	UJ254		<i>Brute Force Non Greaseable</i>	UJ254
	(For Aluminum Drive Shaft)	UJ354C		(For Aluminum Drive Shaft)	UJ354C
	U-Joint (Front Axle Left Outer) Ⓖ	UJ231		U-Joint (Front Axle Left Outer) Ⓖ	UJ371
	(For Aluminum Drive Shaft)	UJ231C		<i>Brute Force Greaseable</i>	UJ377
	U-Joint (Front Axle Right Inner) Ⓖ	UJ231		<i>Brute Force Non Greaseable</i>	UJ371
	(For Aluminum Drive Shaft)	UJ231C		U-Joint (Front Axle Right Inner) Ⓖ	UJ371
	U-Joint (Front Axle Right Outer) Ⓖ	UJ231		<i>Brute Force Greaseable</i>	UJ377
	(For Aluminum Drive Shaft)	UJ231C		<i>Brute Force Non Greaseable</i>	UJ371
	H Yoke	UJ647		U-Joint (Front Axle Right Outer) Ⓖ	UJ371
				<i>Brute Force Greaseable</i>	UJ377
				<i>Brute Force Non Greaseable</i>	UJ371
				H Yoke	UJ647

(Continued)

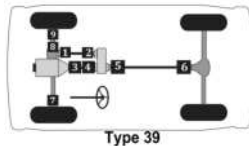

436 ▲ For Use w/ 1.063" Bearing Cap Application. Ⓐ For Use w/ 1.188" Bearing Cap Application. ◇ For Use w/ Inner Lock Ring Application on Half Shaft. □ For Use w/ Outer Lock Ring Application on Half Shaft.



Passenger cars, light & medium trucks

(Cont.) -- Ford Truck 3/4 ton

MFG./YEAR	MODEL & LOCATION	PART NO.	MFG./YEAR	MODEL & LOCATION	PART NO.
Drive Shaft (4 W/D) (Cont.)			Drive Shaft (4 W/D) (Cont.)		
U-Joint (Cont.)			U-Joint (Cont.)		
1977	F-250 w/ 3.875" Intm. Shaft Yoke, Full Time Transfer Case & Inner Lock Ring Wheel Joints: [Type 39]		1977	F-250 w/ 3.5" Intm. Shaft Yoke, Part Time Transfer Case & Inner Lock Ring Joints: [Type 39]	
	U-Joint (Frnt. Shaft; Frt.) ①	UJ369		U-Joint (Frnt. Shaft; Frt.) ①	UJ353
	<i>Brute Force Greaseable</i>	UJ280		<i>Brute Force Greaseable</i>	UJ275
	<i>Brute Force Non Greaseable</i>	UJ269		U-Joint (Frnt. Shaft; Rr.) ②	UJ353
	(For Aluminum Drive Shaft)	UJ369C		<i>Brute Force Greaseable</i>	UJ275
	U-Joint (Frnt. Shaft; Rr.) ②	[2] UJ379		U-Joint (Intmd. Shaft; Frt.) ③	UJ353
	<i>Brute Force Greaseable</i>	UJ280		<i>Brute Force Greaseable</i>	UJ275
	<i>Brute Force Non Greaseable</i>	UJ269		U-Joint (Intmd. Shaft; Rr.) ④	UJ353
	U-Joint (Intmd. Shaft; Frt.) ③	UJ354		<i>Brute Force Greaseable</i>	UJ275
	<i>Brute Force Greaseable</i>	UJ270		U-Joint (Rr. Shaft; Frt.) ⑤	UJ354
	<i>Brute Force Non Greaseable</i>	UJ254		<i>Brute Force Greaseable</i>	UJ270
	(For Aluminum Drive Shaft)	UJ354C		<i>Brute Force Non Greaseable</i>	UJ254
	U-Joint (Intmd. Shaft; Rr.) ④	UJ354		(For Aluminum Drive Shaft)	UJ354C
	<i>Brute Force Greaseable</i>	UJ270		U-Joint (Rr. Shaft; Rr.) ⑥	UJ354
	<i>Brute Force Non Greaseable</i>	UJ254		<i>Brute Force Greaseable</i>	UJ270
	(For Aluminum Drive Shaft)	UJ354C		<i>Brute Force Non Greaseable</i>	UJ254
	U-Joint (Rr. Shaft; Frt.) ⑤	[2] UJ379		(For Aluminum Drive Shaft)	UJ354C
	<i>Brute Force Greaseable</i>	UJ280		U-Joint (Front Axle Left Outer) ⑦	UJ371
	<i>Brute Force Non Greaseable</i>	UJ269		<i>Brute Force Greaseable</i>	UJ377
	U-Joint (Rr. Shaft; Rr.) ⑥	UJ369		<i>Brute Force Non Greaseable</i>	UJ371
	<i>Brute Force Greaseable</i>	UJ280		U-Joint (Front Axle Right Inner) ⑧	UJ371
	<i>Brute Force Non Greaseable</i>	UJ269		<i>Brute Force Greaseable</i>	UJ377
	(For Aluminum Drive Shaft)	UJ369C		<i>Brute Force Non Greaseable</i>	UJ371
	U-Joint (Front Axle Left Outer) ⑦	UJ371		U-Joint (Front Axle Right Outer) ⑨	UJ371
	<i>Brute Force Greaseable</i>	UJ377		<i>Brute Force Greaseable</i>	UJ377
	<i>Brute Force Non Greaseable</i>	UJ371		<i>Brute Force Non Greaseable</i>	UJ371
	U-Joint (Front Axle Right Inner) ⑧	UJ371		Centering Yoke	UJ607
	<i>Brute Force Greaseable</i>	UJ377		H Yoke	UJ647
	<i>Brute Force Non Greaseable</i>	UJ371			(Continued)
	U-Joint (Front Axle Right Outer) ⑨	UJ371			
	<i>Brute Force Greaseable</i>	UJ377			
	<i>Brute Force Non Greaseable</i>	UJ371			

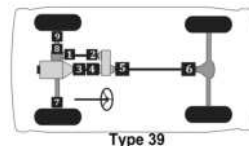

Passenger cars, light & medium trucks

Ford Truck 3/4 ton -- (Cont.)

MFG./YEAR	MODEL & LOCATION	PART NO.	MFG./YEAR	MODEL & LOCATION	PART NO.
Drive Shaft (4 W/D) (Cont.)			Drive Shaft (4 W/D) (Cont.)		
U-Joint (Cont.)			U-Joint (Cont.)		
1977	F-250 w/ 3.5" Intm. Shaft Yoke, Full Time Transfer Case & Inner Lock Ring Wheel Joints: [Type 39]		1976-1975	F-250 w/ Full Time Transfer Case & Outer Lock Ring Wheel Joints: [Type 39]	
	U-Joint (Frnt. Shaft; Frt.) ①	UJ369		U-Joint (Frnt. Shaft; Frt.) ①	UJ369
	<i>Brute Force Greaseable</i>	UJ280		<i>Brute Force Greaseable</i>	UJ280
	<i>Brute Force Non Greaseable</i>	UJ269		<i>Brute Force Non Greaseable</i>	UJ269
	(For Aluminum Drive Shaft)	UJ369C		(For Aluminum Drive Shaft)	UJ369C
	U-Joint (Frnt. Shaft; Rr.) ②	[2] UJ379		U-Joint (Frnt. Shaft; Rr.) ②	[2] UJ379
	<i>Brute Force Greaseable</i>	UJ280		<i>Brute Force Greaseable</i>	UJ280
	<i>Brute Force Non Greaseable</i>	UJ269		<i>Brute Force Non Greaseable</i>	UJ269
	U-Joint (Intmd. Shaft; Frt.) ③	UJ353		U-Joint (Intmd. Shaft; Frt.) ③	UJ353
	<i>Brute Force Greaseable</i>	UJ275		<i>Brute Force Greaseable</i>	UJ275
	U-Joint (Intmd. Shaft; Rr.) ④	UJ353		U-Joint (Intmd. Shaft; Rr.) ④	UJ369
	<i>Brute Force Greaseable</i>	UJ275		<i>Brute Force Greaseable</i>	UJ280
	U-Joint (Rr. Shaft; Frt.) ⑤	[2] UJ379		U-Joint (Rr. Shaft; Frt.) ⑤	UJ269
	<i>Brute Force Greaseable</i>	UJ280		(For Aluminum Drive Shaft)	UJ369C
	<i>Brute Force Non Greaseable</i>	UJ269		U-Joint (Rr. Shaft; Frt.) ⑤	[2] UJ379
	U-Joint (Rr. Shaft; Rr.) ⑥	UJ369		<i>Brute Force Greaseable</i>	UJ280
	<i>Brute Force Greaseable</i>	UJ280		<i>Brute Force Non Greaseable</i>	UJ269
	<i>Brute Force Non Greaseable</i>	UJ269		U-Joint (Rr. Shaft; Rr.) ⑥	UJ369
	(For Aluminum Drive Shaft)	UJ369C		<i>Brute Force Greaseable</i>	UJ280
	U-Joint (Front Axle Left Outer) ⑦	UJ371		<i>Brute Force Non Greaseable</i>	UJ269
	<i>Brute Force Greaseable</i>	UJ377		(For Aluminum Drive Shaft)	UJ369C
	<i>Brute Force Non Greaseable</i>	UJ371		U-Joint (Front Axle Left Outer) ⑦	UJ231
	U-Joint (Front Axle Right Inner) ⑧	UJ371		(For Aluminum Drive Shaft)	UJ231C
	<i>Brute Force Greaseable</i>	UJ377		U-Joint (Front Axle Right Inner) ⑧	UJ231
	<i>Brute Force Non Greaseable</i>	UJ371		(For Aluminum Drive Shaft)	UJ231C
	U-Joint (Front Axle Right Outer) ⑨	UJ371		U-Joint (Front Axle Right Outer) ⑨	UJ231
	<i>Brute Force Greaseable</i>	UJ377		(For Aluminum Drive Shaft)	UJ231C
	<i>Brute Force Non Greaseable</i>	UJ371		Centering Yoke	UJ607
	Centering Yoke	UJ607		H Yoke	UJ647
	H Yoke	UJ647			(Continued)

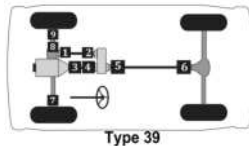

438 ▲ For Use w/ 1.063" Bearing Cap Application. ⊙ For Use w/ 1.188" Bearing Cap Application. ◇ For Use w/ Inner Lock Ring Application on Half Shaft. □ For Use w/ Outer Lock Ring Application on Half Shaft.

Passenger cars, light & medium trucks

(Cont.) -- Ford Truck 3/4 ton

MFG./YEAR	MODEL & LOCATION	PART NO.	MFG./YEAR	MODEL & LOCATION	PART NO.
Drive Shaft (4 W/D) (Cont.)			Drive Shaft (4 W/D) (Cont.)		
U-Joint (Cont.)			U-Joint (Cont.)		
1976-1975 F-250 w/ 3.5" Intm. Shaft Yoke, 133"			1976-1975 F-250 w/ 3.5" Intm. Shaft Yoke, 150"		
Wheel Base, Part Time Transfer Case & Outer Lock Ring Wheel Joints:			Wheel Base, Part Time Transfer Case & Outer Lock Ring Wheel Joints:		
[Type 39]			[Type 39]		
U-Joint (Frnt. Shaft; Frnt.) ^①		UJ353	U-Joint (Frnt. Shaft; Frnt.) ^①		UJ353
Brute Force Greaseable		UJ275	Brute Force Greaseable		UJ275
U-Joint (Frnt. Shaft; Rr.) ^②		UJ353	U-Joint (Frnt. Shaft; Rr.) ^②		UJ353
Brute Force Greaseable		UJ275	Brute Force Greaseable		UJ275
U-Joint (Intmd. Shaft; Frnt.) ^③		UJ369	U-Joint (Intmd. Shaft; Frnt.) ^③		UJ369
Brute Force Greaseable		UJ280	Brute Force Greaseable		UJ280
Brute Force Non Greaseable		UJ269	Brute Force Non Greaseable		UJ269
(For Aluminum Drive Shaft)		UJ369C	(For Aluminum Drive Shaft)		UJ369C
U-Joint (Intmd. Shaft; Rr.) ^④		UJ369	U-Joint (Intmd. Shaft; Rr.) ^④		UJ369
Brute Force Greaseable		UJ280	Brute Force Greaseable		UJ280
Brute Force Non Greaseable		UJ269	Brute Force Non Greaseable		UJ269
(For Aluminum Drive Shaft)		UJ369C	(For Aluminum Drive Shaft)		UJ369C
U-Joint (Rr. Shaft; Frnt.) ^⑤		UJ353	U-Joint (Rr. Shaft; Frnt.) ^⑤		UJ369
Brute Force Greaseable		UJ275	Brute Force Greaseable		UJ280
U-Joint (Rr. Shaft; Rr.) ^⑥		UJ353	Brute Force Non Greaseable		UJ269
Brute Force Greaseable		UJ275	(For Aluminum Drive Shaft)		UJ369C
U-Joint (Front Axle Left Outer) ^⑦		UJ231	U-Joint (Rr. Shaft; Rr.) ^⑥		UJ369
(For Aluminum Drive Shaft)		UJ231C	Brute Force Greaseable		UJ280
U-Joint (Front Axle Right Inner) ^⑧		UJ231	Brute Force Non Greaseable		UJ269
(For Aluminum Drive Shaft)		UJ231C	(For Aluminum Drive Shaft)		UJ369C
U-Joint (Front Axle Right Outer) ^⑨		UJ231	U-Joint (Front Axle Left Outer) ^⑦		UJ231
(For Aluminum Drive Shaft)		UJ231C	(For Aluminum Drive Shaft)		UJ231C
			U-Joint (Front Axle Right Inner) ^⑧		UJ231
			(For Aluminum Drive Shaft)		UJ231C
			U-Joint (Front Axle Right Outer) ^⑨		UJ231
			(For Aluminum Drive Shaft)		UJ231C

(Continued)

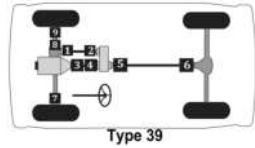

Passenger cars, light & medium trucks

Ford Truck 3/4 ton -- (Cont.)

MFG./YEAR	MODEL & LOCATION	PART NO.	MFG./YEAR	MODEL & LOCATION	PART NO.
-----------	------------------	----------	-----------	------------------	----------

Drive Shaft (4 W/D) (Cont.)

U-Joint (Cont.)

1976-1975 F-250 w/ 3.875" Intm. Shaft Yoke, 133"
Wheel Base, Part Time Transfer Case
& Outer Lock Ring Wheel Joints:

[Type 39]

U-Joint (Frt. Shaft; Frt.) ^①	UJ353
Brute Force Greaseable	UJ275
U-Joint (Frt. Shaft; Rr.) ^②	UJ353
Brute Force Greaseable	UJ275
U-Joint (Intmd. Shaft; Frt.) ^③	UJ353
Brute Force Greaseable	UJ275
U-Joint (Intmd. Shaft; Rr.) ^④	UJ353
Brute Force Greaseable	UJ275
U-Joint (Rr. Shaft; Frt.) ^⑤	UJ353
Brute Force Greaseable	UJ275
U-Joint (Rr. Shaft; Rr.) ^⑥	UJ353
Brute Force Greaseable	UJ275
U-Joint (Front Axle Left Outer) ^⑦	UJ231
(For Aluminum Drive Shaft)	UJ231C
U-Joint (Front Axle Right Inner) ^⑧	UJ231
(For Aluminum Drive Shaft)	UJ231C
U-Joint (Front Axle Right Outer) ^⑨	UJ231
(For Aluminum Drive Shaft)	UJ231C

Drive Shaft (4 W/D) (Cont.)

U-Joint (Cont.)

1976-1975 F-250 w/ 3.875" Intm. Shaft Yoke, 150"
Wheel Base, Part Time Transfer Case
& Outer Lock Ring Wheel Joints:

[Type 39]

U-Joint (Frt. Shaft; Frt.) ^①	UJ353
Brute Force Greaseable	UJ275
U-Joint (Frt. Shaft; Rr.) ^②	UJ353
Brute Force Greaseable	UJ275
U-Joint (Intmd. Shaft; Frt.) ^③	UJ353
Brute Force Greaseable	UJ275
U-Joint (Intmd. Shaft; Rr.) ^④	UJ353
Brute Force Greaseable	UJ275
U-Joint (Rr. Shaft; Frt.) ^⑤	UJ369
Brute Force Greaseable	UJ280
Brute Force Non Greaseable	UJ269
(For Aluminum Drive Shaft)	UJ369C
U-Joint (Rr. Shaft; Rr.) ^⑥	UJ369
Brute Force Greaseable	UJ280
Brute Force Non Greaseable	UJ269
(For Aluminum Drive Shaft)	UJ369C
U-Joint (Front Axle Left Outer) ^⑦	UJ231
(For Aluminum Drive Shaft)	UJ231C
U-Joint (Front Axle Right Inner) ^⑧	UJ231
(For Aluminum Drive Shaft)	UJ231C
U-Joint (Front Axle Right Outer) ^⑨	UJ231
(For Aluminum Drive Shaft)	UJ231C

(Continued)

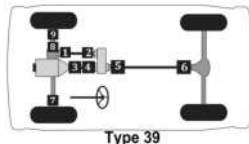

440 ▲ For Use w/ 1.063" Bearing Cap Application. ⊙ For Use w/ 1.188" Bearing Cap Application. ◇ For Use w/ Inner Lock Ring Application on Half Shaft. □ For Use w/ Outer Lock Ring Application on Half Shaft.

Passenger cars, light & medium trucks

(Cont.) -- Ford Truck 3/4 ton

MFG./YEAR	MODEL & LOCATION	PART NO.	MFG./YEAR	MODEL & LOCATION	PART NO.
Drive Shaft (4 W/D) (Cont.)			Drive Shaft (4 W/D) (Cont.)		
U-Joint (Cont.)			U-Joint (Cont.)		
1976-1975 F-250 w/ 3.875" Intm. Shaft Yoke, 150"			1976-1975 F-250 w/ 3.875" Intm. Shaft Yoke, 133"		
Wheel Base, Part Time Transfer Case & Inner Lock Ring Wheel Joints:			Wheel Base, Part Time Transfer Case & Inner Lock Ring Wheel Joints:		
[Type 39]			[Type 39]		
U-Joint (Frnt. Shaft; Frt.) ^①		UJ353	U-Joint (Frnt. Shaft; Frt.) ^①		UJ353
Brute Force Greaseable		UJ275	Brute Force Greaseable		UJ275
U-Joint (Frnt. Shaft; Rr.) ^②		UJ353	U-Joint (Frnt. Shaft; Rr.) ^②		UJ353
Brute Force Greaseable		UJ275	Brute Force Greaseable		UJ275
U-Joint (Intmd. Shaft; Frt.) ^③		UJ353	U-Joint (Intmd. Shaft; Frt.) ^③		UJ353
Brute Force Greaseable		UJ275	Brute Force Greaseable		UJ275
U-Joint (Intmd. Shaft; Rr.) ^④		UJ353	U-Joint (Intmd. Shaft; Rr.) ^④		UJ353
Brute Force Greaseable		UJ275	Brute Force Greaseable		UJ275
U-Joint (Rr. Shaft; Frt.) ^⑤		UJ369	U-Joint (Rr. Shaft; Frt.) ^⑤		UJ353
Brute Force Greaseable		UJ280	Brute Force Greaseable		UJ275
Brute Force Non Greaseable		UJ269	U-Joint (Rr. Shaft; Rr.) ^⑥		UJ353
(For Aluminum Drive Shaft)		UJ369C	Brute Force Greaseable		UJ275
U-Joint (Rr. Shaft; Rr.) ^⑥		UJ369	U-Joint (Front Axle Left Outer) ^⑦		UJ371
Brute Force Greaseable		UJ280	Brute Force Greaseable		UJ377
Brute Force Non Greaseable		UJ269	Brute Force Non Greaseable		UJ371
(For Aluminum Drive Shaft)		UJ369C	U-Joint (Front Axle Right Inner) ^⑧		UJ371
U-Joint (Front Axle Left Outer) ^⑦		UJ371	Brute Force Greaseable		UJ377
Brute Force Greaseable		UJ377	Brute Force Non Greaseable		UJ371
Brute Force Non Greaseable		UJ371	U-Joint (Front Axle Right Outer) ^⑨		UJ371
U-Joint (Front Axle Right Inner) ^⑧		UJ371	Brute Force Greaseable		UJ377
Brute Force Greaseable		UJ377	Brute Force Non Greaseable		UJ371
Brute Force Non Greaseable		UJ371			(Continued)
U-Joint (Front Axle Right Outer) ^⑨		UJ371			
Brute Force Greaseable		UJ377			
Brute Force Non Greaseable		UJ371			

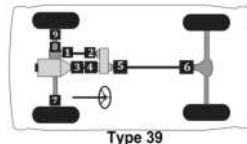

Passenger cars, light & medium trucks

Ford Truck 3/4 ton -- (Cont.)

MFG./YEAR	MODEL & LOCATION	PART NO.	MFG./YEAR	MODEL & LOCATION	PART NO.
-----------	------------------	----------	-----------	------------------	----------

Drive Shaft (4 W/D) (Cont.)

U-Joint (Cont.)

1976-1975 F-250 w/ 3.5" Intm. Shaft Yoke, 133"

Wheel Base, Part Time Transfer Case
& Inner Lock Ring Wheel Joints:

[Type 39]

U-Joint (Frt. Shaft; Frt.) [ⓐ]	UJ353
Brute Force Greaseable	UJ275
U-Joint (Frt. Shaft; Rr.) [ⓑ]	UJ353
Brute Force Greaseable	UJ275
U-Joint (Intmd. Shaft; Frt.) [ⓐ]	UJ369
Brute Force Greaseable	UJ280
Brute Force Non Greaseable	UJ269
(For Aluminum Drive Shaft)	UJ369C
U-Joint (Intmd. Shaft; Rr.) [ⓑ]	UJ369
Brute Force Greaseable	UJ280
Brute Force Non Greaseable	UJ269
(For Aluminum Drive Shaft)	UJ369C
U-Joint (Rr. Shaft; Frt.) [ⓐ]	UJ353
Brute Force Greaseable	UJ275
U-Joint (Rr. Shaft; Rr.) [ⓑ]	UJ353
Brute Force Greaseable	UJ275
U-Joint (Front Axle Left Outer) [ⓐ]	UJ371
Brute Force Greaseable	UJ377
Brute Force Non Greaseable	UJ371
U-Joint (Front Axle Right Inner) [ⓐ]	UJ371
Brute Force Greaseable	UJ377
Brute Force Non Greaseable	UJ371
U-Joint (Front Axle Right Outer) [ⓐ]	UJ371
Brute Force Greaseable	UJ377
Brute Force Non Greaseable	UJ371

Drive Shaft (4 W/D) (Cont.)

U-Joint (Cont.)

1976-1975 F-250 w/ 3.5" Intm. Shaft Yoke, 150"

Wheel Base, Part Time Transfer Case
& Inner Lock Ring Wheel Joints:

[Type 39]

U-Joint (Frt. Shaft; Frt.) [ⓐ]	UJ353
Brute Force Greaseable	UJ275
U-Joint (Frt. Shaft; Rr.) [ⓑ]	UJ353
Brute Force Greaseable	UJ275
U-Joint (Intmd. Shaft; Frt.) [ⓐ]	UJ369
Brute Force Greaseable	UJ280
Brute Force Non Greaseable	UJ269
(For Aluminum Drive Shaft)	UJ369C
U-Joint (Intmd. Shaft; Rr.) [ⓑ]	UJ369
Brute Force Greaseable	UJ280
Brute Force Non Greaseable	UJ269
(For Aluminum Drive Shaft)	UJ369C
U-Joint (Rr. Shaft; Frt.) [ⓐ]	UJ369
Brute Force Greaseable	UJ280
Brute Force Non Greaseable	UJ269
(For Aluminum Drive Shaft)	UJ369C
U-Joint (Rr. Shaft; Rr.) [ⓑ]	UJ369
Brute Force Greaseable	UJ280
Brute Force Non Greaseable	UJ269
(For Aluminum Drive Shaft)	UJ369C
U-Joint (Front Axle Left Outer) [ⓐ]	UJ371
Brute Force Greaseable	UJ377
Brute Force Non Greaseable	UJ371
U-Joint (Front Axle Right Inner) [ⓐ]	UJ371
Brute Force Greaseable	UJ377
Brute Force Non Greaseable	UJ371
U-Joint (Front Axle Right Outer) [ⓐ]	UJ371
Brute Force Greaseable	UJ377
Brute Force Non Greaseable	UJ371

(Continued)

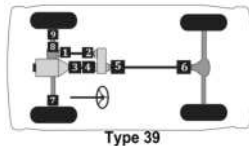

442 ▲ For Use w/ 1.063" Bearing Cap Application. ⓐ For Use w/ 1.188" Bearing Cap Application. ◇ For Use w/ Inner Lock Ring Application on Half Shaft. □ For Use w/ Outer Lock Ring Application on Half Shaft.

MFG./YEAR	MODEL & LOCATION	PART NO.	MFG./YEAR	MODEL & LOCATION	PART NO.
Drive Shaft (4 W/D) (Cont.)			Drive Shaft (4 W/D) (Cont.)		
U-Joint (Cont.)			U-Joint (Cont.)		
1976-1975 F-250 w/ Full Time Transfer Case & Inner Lock Ring Wheel Joints: [Type 39]			1974-1959 F-250 w/ Outer Lock Ring Wheel Joints: [Type 34]		
	U-Joint (Frnt. Shaft; Frt.) ①	UJ369		U-Joint (Frnt. Shaft; Frt.) ①	UJ353
	<i>Brute Force Greaseable</i>	UJ280		<i>Brute Force Greaseable</i>	UJ275
	<i>Brute Force Non Greaseable</i>	UJ269		U-Joint (Frnt. Shaft; Rr.) ②	UJ353
	(For Aluminum Drive Shaft)	UJ369C		<i>Brute Force Greaseable</i>	UJ275
	U-Joint (Frnt. Shaft; Rr.) ②	[2] UJ379		U-Joint (Intmd. Shaft; Frt.) ③	UJ369
	<i>Brute Force Greaseable</i>	UJ280		<i>Brute Force Greaseable</i>	UJ280
	<i>Brute Force Non Greaseable</i>	UJ269		<i>Brute Force Non Greaseable</i>	UJ269
	(For Aluminum Drive Shaft)	UJ369C		U-Joint (Intmd. Shaft; Rr.) ④	UJ369
	U-Joint (Intmd. Shaft; Frt.) ③	UJ353		<i>Brute Force Greaseable</i>	UJ280
	<i>Brute Force Greaseable</i>	UJ275		<i>Brute Force Non Greaseable</i>	UJ269
	U-Joint (Intmd. Shaft; Rr.) ④	UJ369		(For Aluminum Drive Shaft)	UJ369C
	<i>Brute Force Greaseable</i>	UJ280		U-Joint (Rr. Shaft; Frt.) ⑤	UJ353
	<i>Brute Force Non Greaseable</i>	UJ269		<i>Brute Force Greaseable</i>	UJ275
	(For Aluminum Drive Shaft)	UJ369C		U-Joint (Rr. Shaft; Rr.) ⑥	UJ353
	U-Joint (Rr. Shaft; Frt.) ⑤	[2] UJ379		<i>Brute Force Greaseable</i>	UJ275
	<i>Brute Force Greaseable</i>	UJ280		U-Joint (Wheel Joint) ⑦	[2] UJ231
	<i>Brute Force Non Greaseable</i>	UJ269		(For Aluminum Drive Shaft)	UJ231C
	U-Joint (Rr. Shaft; Rr.) ⑥	UJ369		1974-1959 F-250 w/ Inner Lock Ring Wheel Joints: [Type 34]	
	<i>Brute Force Greaseable</i>	UJ280		U-Joint (Frnt. Shaft; Frt.) ①	UJ353
	<i>Brute Force Non Greaseable</i>	UJ269		<i>Brute Force Greaseable</i>	UJ275
	(For Aluminum Drive Shaft)	UJ369C		U-Joint (Frnt. Shaft; Rr.) ②	UJ353
	U-Joint (Front Axle Left Outer) ⑦	UJ371		<i>Brute Force Greaseable</i>	UJ275
	<i>Brute Force Greaseable</i>	UJ377		U-Joint (Intmd. Shaft; Frt.) ③	UJ369
	<i>Brute Force Non Greaseable</i>	UJ371		<i>Brute Force Greaseable</i>	UJ280
	U-Joint (Front Axle Right Inner) ⑧	UJ371		<i>Brute Force Non Greaseable</i>	UJ269
	<i>Brute Force Greaseable</i>	UJ377		(For Aluminum Drive Shaft)	UJ369C
	<i>Brute Force Non Greaseable</i>	UJ371		U-Joint (Intmd. Shaft; Rr.) ④	UJ369
	U-Joint (Front Axle Right Outer) ⑧	UJ371		<i>Brute Force Greaseable</i>	UJ280
	<i>Brute Force Greaseable</i>	UJ377		<i>Brute Force Non Greaseable</i>	UJ269
	<i>Brute Force Non Greaseable</i>	UJ371		(For Aluminum Drive Shaft)	UJ369C
	H Yoke	UJ647		U-Joint (Rr. Shaft; Frt.) ⑤	UJ353
				<i>Brute Force Greaseable</i>	UJ275
				U-Joint (Rr. Shaft; Rr.) ⑥	UJ353
				<i>Brute Force Greaseable</i>	UJ275
				U-Joint (Wheel Joint) ⑦	[2] UJ365
				<i>Brute Force Greaseable</i>	UJ378
				<i>Brute Force Non Greaseable</i>	UJ365

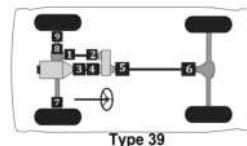
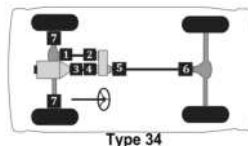

Passenger cars, light & medium trucks

Ford Truck 1 ton

MFG./YEAR	MODEL & LOCATION	PART NO.	MFG./YEAR	MODEL & LOCATION	PART NO.
Drive Shaft (2 W/D)			Drive Shaft (2 W/D) (Cont.)		
U-Joint			U-Joint (Cont.)		
2020-2007 F-350 Super Duty w/ Single Rear Whls. & 2 Joint Driveshaft: [Type 1]			2008-1999 F53 w/ 4 Joint Shaft: [Type 3]		
U-Joint (Front)Ⓛ		UJ330	U-Joint (Front)Ⓛ		UJ351
Brute Force Greaseable		UJ295	(For Aluminum Drive Shaft)		UJ351C
(For Aluminum Drive Shaft)		UJ330C	Brute Force Non Greaseable		UJ351BF
U-Joint (Rear)Ⓢ		UJ330	Clamp Kit (Front)		UJ351-10
Brute Force Greaseable		UJ295	U-Joint (Center; Front)Ⓢ		UJ351
(For Aluminum Drive Shaft)		UJ330C	(For Aluminum Drive Shaft)		UJ351C
2020-2007 F-350 Super Duty w/ Single Rear Whls. & 3 Joint Driveshaft: [Type 2]			Brute Force Non Greaseable		UJ351BF
U-Joint (Front)Ⓛ		UJ330	Clamp Kit (Center; Front)		UJ351-10
Brute Force Greaseable		UJ295	U-Joint (Center; Rear)Ⓢ		UJ351
(For Aluminum Drive Shaft)		UJ330C	(For Aluminum Drive Shaft)		UJ351C
U-Joint (Center)Ⓢ		UJ330	Brute Force Non Greaseable		UJ351BF
Brute Force Greaseable		UJ295	Clamp Kit (Center; Rear)		UJ351-10
(For Aluminum Drive Shaft)		UJ330C	U-Joint (Rear)Ⓢ		UJ351
U-Joint (Rear)Ⓢ		UJ330	(For Aluminum Drive Shaft)		UJ351C
Brute Force Greaseable		UJ295	Brute Force Non Greaseable		UJ351BF
(For Aluminum Drive Shaft)		UJ330C	Clamp Kit (Rear)		UJ351-10
2017-2007 F-350 Super Duty w/ Dual Rear Whls. & 3 Joint Driveshaft: [Type 2]			2006-2005 F-350 Super Duty w/ Reg. Cab & Auto. Trans.: [Type 1]		
U-Joint (Front)Ⓛ		UJ351	U-Joint (Front)Ⓛ		UJ330
(For Aluminum Drive Shaft)		UJ351C	Brute Force Greaseable		UJ295
Brute Force Non Greaseable		UJ351BF	(For Aluminum Drive Shaft)		UJ330C
U-Joint (Center)Ⓢ		UJ351	U-Joint (Rear)Ⓢ		UJ330
(For Aluminum Drive Shaft)		UJ351C	Brute Force Greaseable		UJ295
Brute Force Non Greaseable		UJ351BF	(For Aluminum Drive Shaft)		UJ330C
U-Joint (Rear)Ⓢ		UJ351	2006-2005 F-350 Super Duty w/ Reg. Cab & Man. Trans.: [Type 2]		
(For Aluminum Drive Shaft)		UJ351C	U-Joint (Front)Ⓛ		UJ330
Brute Force Non Greaseable		UJ351BF	Brute Force Greaseable		UJ295
2008-1999 F53 w/ 3 Joint Shaft: [Type 2]			(For Aluminum Drive Shaft)		UJ330C
U-Joint (Front)Ⓛ		UJ351	U-Joint (Center)Ⓢ		UJ330
(For Aluminum Drive Shaft)		UJ351C	Brute Force Greaseable		UJ295
Brute Force Non Greaseable		UJ351BF	(For Aluminum Drive Shaft)		UJ330C
Clamp Kit (Front)		UJ351-10	U-Joint (Rear)Ⓢ		UJ330
U-Joint (Center)Ⓢ		UJ351	Brute Force Greaseable		UJ295
(For Aluminum Drive Shaft)		UJ351C	(For Aluminum Drive Shaft)		UJ330C
Brute Force Non Greaseable		UJ351BF	2006-2005 F-350 Super Duty w/ Ext. Cab & Crew Cab: [Type 2]		
Clamp Kit (Center)		UJ351-10	U-Joint (Front)Ⓛ		UJ330
U-Joint (Rear)Ⓢ		UJ351	Brute Force Greaseable		UJ295
(For Aluminum Drive Shaft)		UJ351C	(For Aluminum Drive Shaft)		UJ330C
Brute Force Non Greaseable		UJ351BF	U-Joint (Center)Ⓢ		UJ330
Clamp Kit (Rear)		UJ351-10	Brute Force Greaseable		UJ295
			(For Aluminum Drive Shaft)		UJ330C
			U-Joint (Rear)Ⓢ		UJ330
			Brute Force Greaseable		UJ295
			(For Aluminum Drive Shaft)		UJ330C

(Continued)

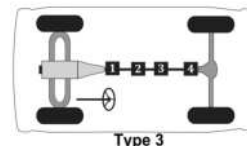
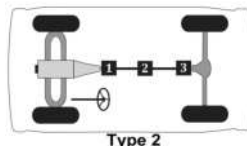
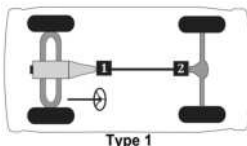

MFG./YEAR	MODEL & LOCATION	PART NO.	MFG./YEAR	MODEL & LOCATION	PART NO.
Drive Shaft (2 W/D) (Cont.)			Drive Shaft (2 W/D) (Cont.)		
U-Joint (Cont.)			U-Joint (Cont.)		
2004-1999 F-350 Super Duty w/ Reg. Cab, Auto.			2004-1999 F-350 Super Duty w/ Reg. Cab, Man.		
Trans. & 5.4L Eng.: [Type 1]			Trans. & 6.0L, 6.8L & 7.3L Engs.: [Type 2]		
U-Joint (Front)Ⓢ		UJ330	U-Joint (Front)Ⓢ		UJ330
Brute Force Greaseable		UJ295	Brute Force Greaseable		UJ295
(For Aluminum Drive Shaft)		UJ330C	(For Aluminum Drive Shaft)		UJ330C
Clamp Kit (Front)		UJ331-10	Clamp Kit (Front)		UJ331-10
U-Joint (Rear)Ⓢ		UJ330	U-Joint (Center)Ⓢ		UJ330
Brute Force Greaseable		UJ295	Brute Force Greaseable		UJ295
(For Aluminum Drive Shaft)		UJ330C	(For Aluminum Drive Shaft)		UJ330C
Clamp Kit (Rear)		UJ331-10	Clamp Kit (Center)		UJ331-10
2004-1999 F-350 Super Duty w/ Reg. Cab, Man.			2004-1999 F-350 Super Duty w/ Ext. Cab, Crew		
Trans. & 5.4L Eng.: [Type 2]			Cab & 6.0L, 6.8L & 7.3L Engs.: [Type 2]		
U-Joint (Front)Ⓢ		UJ330	U-Joint (Front)Ⓢ		UJ330
Brute Force Greaseable		UJ295	Brute Force Greaseable		UJ295
(For Aluminum Drive Shaft)		UJ330C	(For Aluminum Drive Shaft)		UJ330C
Clamp Kit (Front)		UJ331-10	Clamp Kit (Front)		UJ331-10
U-Joint (Center)Ⓢ		UJ330	U-Joint (Center)Ⓢ		UJ330
Brute Force Greaseable		UJ295	Brute Force Greaseable		UJ295
(For Aluminum Drive Shaft)		UJ330C	(For Aluminum Drive Shaft)		UJ330C
Clamp Kit (Center)		UJ331-10	Clamp Kit (Center)		UJ331-10
U-Joint (Rear)Ⓢ		UJ330	U-Joint (Rear)Ⓢ		UJ330
Brute Force Greaseable		UJ295	Brute Force Greaseable		UJ295
(For Aluminum Drive Shaft)		UJ330C	(For Aluminum Drive Shaft)		UJ330C
Clamp Kit (Rear)		UJ331-10	Clamp Kit (Rear)		UJ331-10
2004-1999 F-350 Super Duty w/ Ext. Cab, Crew			1997 F-350 w/ 2 Joint Shaft & 5.8L Eng.: [Type 1]		
Cab & 5.4L Eng.: [Type 2]			[Type 1]		
U-Joint (Front)Ⓢ		UJ330	U-Joint (Front)Ⓢ		UJ354
Brute Force Greaseable		UJ295	Brute Force Greaseable		UJ270
(For Aluminum Drive Shaft)		UJ330C	Brute Force Non Greaseable		UJ254
Clamp Kit (Front)		UJ331-10	(For Aluminum Drive Shaft)		UJ354C
U-Joint (Center)Ⓢ		UJ330	U-Joint (Rear)Ⓢ		UJ434
Brute Force Greaseable		UJ295	Brute Force Greaseable		UJ265
(For Aluminum Drive Shaft)		UJ330C	Brute Force Non Greaseable		UJ264
Clamp Kit (Center)		UJ331-10	U-Bolt Kit (Rear)		UJ534-10
U-Joint (Rear)Ⓢ		UJ330			(Continued)
Brute Force Greaseable		UJ295			
(For Aluminum Drive Shaft)		UJ330C			
Clamp Kit (Rear)		UJ331-10			
2004-1999 F-350 Super Duty w/ Reg. Cab, Auto.					
Trans. & 6.0L, 6.8L & 7.3L Engs.: [Type 1]					
U-Joint (Front)Ⓢ		UJ330			
Brute Force Greaseable		UJ295			
(For Aluminum Drive Shaft)		UJ330C			
Clamp Kit (Front)		UJ331-10			
U-Joint (Rear)Ⓢ		UJ330			
Brute Force Greaseable		UJ295			
(For Aluminum Drive Shaft)		UJ330C			
Clamp Kit (Rear)		UJ331-10			

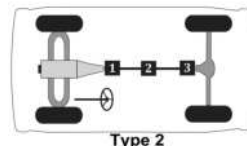
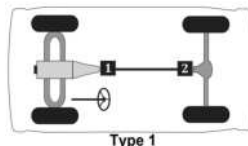

Passenger cars, light & medium trucks

Ford Truck 1 ton -- (Cont.)

MFG./YEAR	MODEL & LOCATION	PART NO.	MFG./YEAR	MODEL & LOCATION	PART NO.
Drive Shaft (2 W/D) (Cont.)			Drive Shaft (2 W/D) (Cont.)		
U-Joint (Cont.)			U-Joint (Cont.)		
1997	F-350 w/ 3 Joint Shaft, 136" & 160" Wheel Base, C6 Auto. Trans. & 5.8L Eng.: [Type 2]		1997	F-350 w/ Man. Trans. & 5.8L Eng.: [Type 2]	
	U-Joint (Front)Ⓚ	UJ331		U-Joint (Front)Ⓚ	UJ434
	Brute Force Greaseable	UJ232		Brute Force Greaseable	UJ265
	Brute Force Non Greaseable	UJ231		Brute Force Non Greaseable	UJ264
	(For Aluminum Drive Shaft)	UJ331C		U-Bolt Kit (Front)	UJ534-10
	Clamp Kit (Front)	UJ331-10		U-Joint (Center)Ⓚ	UJ354
	U-Joint (Center)Ⓚ	UJ331		Brute Force Greaseable	UJ270
	Brute Force Greaseable	UJ232		Brute Force Non Greaseable	UJ254
	Brute Force Non Greaseable	UJ231		(For Aluminum Drive Shaft)	UJ354C
	(For Aluminum Drive Shaft)	UJ331C		U-Joint (Rear)Ⓚ	UJ354
	Clamp Kit (Center)	UJ331-10		Brute Force Greaseable	UJ270
	U-Joint (Rear)Ⓚ	UJ331		Brute Force Non Greaseable	UJ254
	Brute Force Greaseable	UJ232		(For Aluminum Drive Shaft)	UJ354C
	Brute Force Non Greaseable	UJ231		1997-1995 F-350 w/ 2 Joint Shaft, 7.3L & 7.5L Eng.s.: [Type 1]	
	(For Aluminum Drive Shaft)	UJ331C		U-Joint (Front)Ⓚ	UJ331
	Clamp Kit (Rear)	UJ331-10		Brute Force Greaseable	UJ232
1997	F-350 w/ 3 Joint Shaft, 168" Wheel Base, C6 Auto. Trans. & 5.8L Eng.: [Type 2]			Brute Force Non Greaseable	UJ231
	U-Joint (Front)Ⓚ	UJ354		(For Aluminum Drive Shaft)	UJ331C
	Brute Force Greaseable	UJ270		Clamp Kit (Front)	UJ331-10
	Brute Force Non Greaseable	UJ254		U-Joint (Rear)Ⓚ	UJ331
	(For Aluminum Drive Shaft)	UJ354C		Brute Force Greaseable	UJ232
	U-Joint (Center)Ⓚ	UJ354		Brute Force Non Greaseable	UJ231
	Brute Force Greaseable	UJ270		(For Aluminum Drive Shaft)	UJ331C
	Brute Force Non Greaseable	UJ254		Clamp Kit (Rear)	UJ331-10
	(For Aluminum Drive Shaft)	UJ354C		1997-1995 F-350 w/ 3 Joint Shaft, 7.3L & 7.5L Eng.s.: [Type 2]	
	U-Joint (Rear)Ⓚ	UJ434		U-Joint (Front)Ⓚ	UJ331
	Brute Force Greaseable	UJ265		Brute Force Greaseable	UJ232
	Brute Force Non Greaseable	UJ264		Brute Force Non Greaseable	UJ231
	U-Bolt Kit (Rear)	UJ534-10		(For Aluminum Drive Shaft)	UJ331C
1997	F-350 w/ 3 Joint Shaft, E40D Auto. Trans. & 5.8L Eng.: [Type 2]			Clamp Kit (Front)	UJ331-10
	U-Joint (Front)Ⓚ	UJ331		U-Joint (Center)Ⓚ	UJ331
	Brute Force Greaseable	UJ232		Brute Force Greaseable	UJ232
	Brute Force Non Greaseable	UJ231		Brute Force Non Greaseable	UJ231
	(For Aluminum Drive Shaft)	UJ331C		(For Aluminum Drive Shaft)	UJ331C
	Clamp Kit (Front)	UJ331-10		Clamp Kit (Center)	UJ331-10
	U-Joint (Center)Ⓚ	UJ331		U-Joint (Rear)Ⓚ	UJ331
	Brute Force Greaseable	UJ232		Brute Force Greaseable	UJ232
	Brute Force Non Greaseable	UJ231		Brute Force Non Greaseable	UJ231
	(For Aluminum Drive Shaft)	UJ331C		(For Aluminum Drive Shaft)	UJ331C
	Clamp Kit (Center)	UJ331-10		Clamp Kit (Rear)	UJ331-10
	U-Joint (Rear)Ⓚ	UJ331			(Continued)
	Brute Force Greaseable	UJ232			
	Brute Force Non Greaseable	UJ231			
	(For Aluminum Drive Shaft)	UJ331C			
	Clamp Kit (Rear)	UJ331-10			

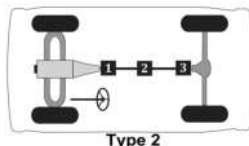
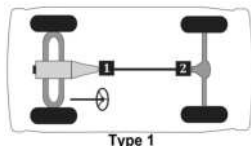

MFG./YEAR	MODEL & LOCATION	PART NO.	MFG./YEAR	MODEL & LOCATION	PART NO.
Drive Shaft (2 W/D) (Cont.)			Drive Shaft (2 W/D) (Cont.)		
U-Joint (Cont.)			U-Joint (Cont.)		
1997-1989 F53 w/ 3 Joint Shaft: [Type 2]			1996-1995 F-350 w/ 3 Joint Shaft & 4.9L Eng.:		
			[Type 2]		
	U-Joint (Front)Ⓢ	UJ330	U-Joint (Front)Ⓢ		UJ354
	<i>Brute Force Greaseable</i>	UJ295	<i>Brute Force Greaseable</i>		UJ270
	(For Aluminum Drive Shaft)	UJ330C	<i>Brute Force Non Greaseable</i>		UJ254
	Clamp Kit (Front)	UJ331-10	(For Aluminum Drive Shaft)		UJ354C
	U-Joint (Center)Ⓢ	UJ330	U-Joint (Center)Ⓢ		UJ354
	<i>Brute Force Greaseable</i>	UJ295	<i>Brute Force Greaseable</i>		UJ270
	(For Aluminum Drive Shaft)	UJ330C	<i>Brute Force Non Greaseable</i>		UJ254
	Clamp Kit (Center)	UJ331-10	(For Aluminum Drive Shaft)		UJ354C
	U-Joint (Rear)Ⓢ	UJ330	U-Joint (Rear)Ⓢ		UJ434
	<i>Brute Force Greaseable</i>	UJ295	<i>Brute Force Greaseable</i>		UJ265
	(For Aluminum Drive Shaft)	UJ330C	<i>Brute Force Non Greaseable</i>		UJ264
	Clamp Kit (Rear)	UJ331-10	U-Bolt Kit (Rear)		UJ534-10
1997-1989 F53 w/ 4 Joint Shaft: [Type 3]			1996-1995 F-350 w/ 2 Joint Shaft, 1.063" Dia. Brg.		
			Cap & 5.8L Eng.: [Type 1]		
	U-Joint (Front)Ⓢ	UJ330	U-Joint (Front)Ⓢ		UJ354
	<i>Brute Force Greaseable</i>	UJ295	<i>Brute Force Greaseable</i>		UJ270
	(For Aluminum Drive Shaft)	UJ330C	<i>Brute Force Non Greaseable</i>		UJ254
	Clamp Kit (Front)	UJ331-10	(For Aluminum Drive Shaft)		UJ354C
	U-Joint (Center; Front)Ⓢ	UJ330	U-Joint (Rear)Ⓢ		UJ434
	<i>Brute Force Greaseable</i>	UJ295	<i>Brute Force Greaseable</i>		UJ265
	(For Aluminum Drive Shaft)	UJ330C	<i>Brute Force Non Greaseable</i>		UJ264
	Clamp Kit (Center; Front)	UJ331-10	U-Bolt Kit (Rear)		UJ534-10
	U-Joint (Center; Rear)Ⓢ	UJ330	1996-1995 F-350 w/ 2 Joint Shaft, 1.188" Dia. Brg.		
	<i>Brute Force Greaseable</i>	UJ295	Cap & 5.8L Eng.: [Type 1]		
	(For Aluminum Drive Shaft)	UJ330C	U-Joint (Front)Ⓢ		UJ331
	Clamp Kit (Center; Rear)	UJ331-10	<i>Brute Force Greaseable</i>		UJ232
	U-Joint (Rear)Ⓢ	UJ330	<i>Brute Force Non Greaseable</i>		UJ231
	<i>Brute Force Greaseable</i>	UJ295	(For Aluminum Drive Shaft)		UJ331C
	(For Aluminum Drive Shaft)	UJ330C	Clamp Kit (Front)		UJ331-10
	Clamp Kit (Rear)	UJ331-10	U-Joint (Rear)Ⓢ		UJ331
1997-1988 F Super Duty: [Type 2]			<i>Brute Force Greaseable</i>		UJ232
	U-Joint (Front)Ⓢ	UJ330	<i>Brute Force Non Greaseable</i>		UJ231
	<i>Brute Force Greaseable</i>	UJ295	(For Aluminum Drive Shaft)		UJ331C
	(For Aluminum Drive Shaft)	UJ330C	Clamp Kit (Rear)		UJ331-10
	Clamp Kit (Front)	UJ331-10	1996-1995 F-350 w/ 3 Joint Shaft, 1.063" Dia. Brg.		
	U-Joint (Center)Ⓢ	UJ330	Cap & 5.8L Eng.: [Type 2]		
	<i>Brute Force Greaseable</i>	UJ295	U-Joint (Front)Ⓢ		UJ354
	(For Aluminum Drive Shaft)	UJ330C	<i>Brute Force Greaseable</i>		UJ270
	Clamp Kit (Center)	UJ331-10	<i>Brute Force Non Greaseable</i>		UJ254
	U-Joint (Rear)Ⓢ	UJ330	(For Aluminum Drive Shaft)		UJ354C
	<i>Brute Force Greaseable</i>	UJ295	U-Joint (Center)Ⓢ		UJ354
	(For Aluminum Drive Shaft)	UJ330C	<i>Brute Force Greaseable</i>		UJ270
	Clamp Kit (Rear)	UJ331-10	<i>Brute Force Non Greaseable</i>		UJ254
	U-Joint (PTO)	UJ338	(For Aluminum Drive Shaft)		UJ354C
1996-1995 F-350 w/ 2 Joint Shaft & 4.9L Eng.:			U-Joint (Rear)Ⓢ		UJ434
			<i>Brute Force Greaseable</i>		UJ265
			<i>Brute Force Non Greaseable</i>		UJ264
			U-Bolt Kit (Rear)		UJ534-10
					(Continued)

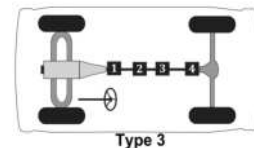
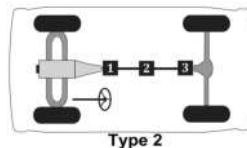
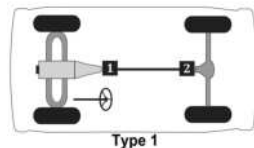

Passenger cars, light & medium trucks

Ford Truck 1 ton -- (Cont.)

MFG./YEAR	MODEL & LOCATION	PART NO.	MFG./YEAR	MODEL & LOCATION	PART NO.
Drive Shaft (2 W/D) (Cont.)			Drive Shaft (2 W/D) (Cont.)		
U-Joint (Cont.)			U-Joint (Cont.)		
1996-1995 F-350 w/ 3 Joint Shaft, 1.188" Dia. Brg.			1994-1992 F-350 w/ Reg. Cab, Man. Trans. & 7.3L		
Cap & 5.8L Eng.: [Type 2]			Eng.: [Type 2]		
U-Joint (Front)Ⓛ		UJ331	U-Joint (Front)Ⓛ		UJ434
Brute Force Greaseable		UJ232	Brute Force Greaseable		UJ265
Brute Force Non Greaseable		UJ231	Brute Force Non Greaseable		UJ264
(For Aluminum Drive Shaft)		UJ331C	U-Bolt Kit (Front)		UJ534-10
Clamp Kit (Front)		UJ331-10	U-Joint (Center)Ⓞ		UJ331
U-Joint (Center)Ⓞ		UJ331	Brute Force Greaseable		UJ232
Brute Force Greaseable		UJ232	Brute Force Non Greaseable		UJ231
Brute Force Non Greaseable		UJ231	(For Aluminum Drive Shaft)		UJ331C
(For Aluminum Drive Shaft)		UJ331C	Clamp Kit (Center)		UJ331-10
Clamp Kit (Center)		UJ331-10	U-Joint (Rear)Ⓞ		UJ331
U-Joint (Rear)Ⓞ		UJ331	Brute Force Greaseable		UJ232
Brute Force Greaseable		UJ232	Brute Force Non Greaseable		UJ231
Brute Force Non Greaseable		UJ231	(For Aluminum Drive Shaft)		UJ331C
(For Aluminum Drive Shaft)		UJ331C	Clamp Kit (Rear)		UJ331-10
Clamp Kit (Rear)		UJ331-10	1994-1992 F-350 w/ Reg. Cab, Man. Trans. & 7.5L		
1994-1992 F-350 w/ Reg. Cab, Auto. Trans., 4.9L			Eng.: [Type 2]		
& 5.8L Eng.: [Type 1]			U-Joint (Front)Ⓛ		UJ331
U-Joint (Front)Ⓛ		UJ354	Brute Force Greaseable		UJ232
Brute Force Greaseable		UJ270	Brute Force Non Greaseable		UJ231
Brute Force Non Greaseable		UJ254	(For Aluminum Drive Shaft)		UJ331C
(For Aluminum Drive Shaft)		UJ354C	Clamp Kit (Front)		UJ331-10
U-Joint (Rear)Ⓞ		UJ434	U-Joint (Center)Ⓞ		UJ331
Brute Force Greaseable		UJ265	Brute Force Greaseable		UJ232
Brute Force Non Greaseable		UJ264	Brute Force Non Greaseable		UJ231
U-Bolt Kit (Rear)		UJ534-10	(For Aluminum Drive Shaft)		UJ331C
1994-1992 F-350 w/ Reg. Cab, Man. Trans., 4.9L			Clamp Kit (Center)		UJ331-10
5.8L Eng.: [Type 2]			U-Joint (Rear)Ⓞ		UJ331
U-Joint (Front)Ⓛ		UJ434	Brute Force Greaseable		UJ232
Brute Force Greaseable		UJ265	Brute Force Non Greaseable		UJ231
Brute Force Non Greaseable		UJ264	(For Aluminum Drive Shaft)		UJ331C
U-Bolt Kit (Front)		UJ534-10	Clamp Kit (Rear)		UJ331-10
U-Joint (Center)Ⓞ		UJ354	1994-1992 F-350 w/ Ext. Cab: [Type 2]		
Brute Force Greaseable		UJ270	U-Joint (Front)Ⓛ		UJ331
Brute Force Non Greaseable		UJ254	Brute Force Greaseable		UJ232
(For Aluminum Drive Shaft)		UJ354C	Brute Force Non Greaseable		UJ231
U-Joint (Rear)Ⓞ		UJ434	(For Aluminum Drive Shaft)		UJ331C
Brute Force Greaseable		UJ265	Clamp Kit (Front)		UJ331-10
Brute Force Non Greaseable		UJ264	U-Joint (Center)Ⓞ		UJ331
U-Bolt Kit (Rear)		UJ534-10	Brute Force Greaseable		UJ232
1994-1992 F-350 w/ Reg. Cab, Auto. Trans., 7.3L			Brute Force Non Greaseable		UJ231
& 7.5L Eng.: [Type 1]			(For Aluminum Drive Shaft)		UJ331C
U-Joint (Front)Ⓛ		UJ354	Clamp Kit (Center)		UJ331-10
Brute Force Greaseable		UJ270	U-Joint (Rear)Ⓞ		UJ331
Brute Force Non Greaseable		UJ254	Brute Force Greaseable		UJ232
(For Aluminum Drive Shaft)		UJ354C	Brute Force Non Greaseable		UJ231
U-Joint (Rear)Ⓞ		UJ434	(For Aluminum Drive Shaft)		UJ331C
Brute Force Greaseable		UJ265	Clamp Kit (Rear)		UJ331-10
Brute Force Non Greaseable		UJ264			
U-Bolt Kit (Rear)		UJ534-10			

(Continued)

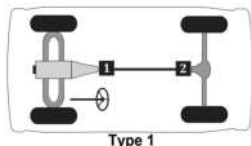

Type 1

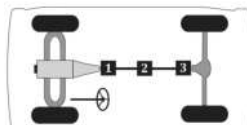

Type 2

MFG./YEAR	MODEL & LOCATION	PART NO.	MFG./YEAR	MODEL & LOCATION	PART NO.
Drive Shaft (2 W/D) (Cont.)			Drive Shaft (2 W/D) (Cont.)		
U-Joint (Cont.)			U-Joint (Cont.)		
1994-1992 F-350 w/ Crew Cab, Auto. Trans. & 5.8L Eng.: [Type 2]			1994-1992 F-350 w/ Crew Cab, Man. Trans. & 7.3L Eng.: [Type 2]		
	U-Joint (Front)Ⓢ	UJ354		U-Joint (Front)Ⓢ	UJ331
	<i>Brute Force Greaseable</i>	UJ270		<i>Brute Force Greaseable</i>	UJ232
	<i>Brute Force Non Greaseable</i>	UJ254		<i>Brute Force Non Greaseable</i>	UJ231
	(For Aluminum Drive Shaft)	UJ354C		(For Aluminum Drive Shaft)	UJ331C
	U-Joint (Center)Ⓢ	UJ354		Clamp Kit (Front)	UJ331-10
	<i>Brute Force Greaseable</i>	UJ270		U-Joint (Center)Ⓢ	UJ331
	<i>Brute Force Non Greaseable</i>	UJ254		<i>Brute Force Greaseable</i>	UJ232
	(For Aluminum Drive Shaft)	UJ354C		<i>Brute Force Non Greaseable</i>	UJ231
	U-Joint (Rear)Ⓢ	UJ434		(For Aluminum Drive Shaft)	UJ331C
	<i>Brute Force Greaseable</i>	UJ265		Clamp Kit (Center)	UJ331-10
	<i>Brute Force Non Greaseable</i>	UJ264		U-Joint (Rear)Ⓢ	UJ331
	U-Bolt Kit (Rear)	UJ534-10		<i>Brute Force Greaseable</i>	UJ232
	1994-1992 F-350 w/ Crew Cab, Man. Trans. & 5.8L Eng.: [Type 2]			<i>Brute Force Non Greaseable</i>	UJ231
	U-Joint (Front)Ⓢ	UJ434		(For Aluminum Drive Shaft)	UJ331C
	<i>Brute Force Greaseable</i>	UJ265		Clamp Kit (Rear)	UJ331-10
	<i>Brute Force Non Greaseable</i>	UJ264		1994-1992 F-350 w/ Crew Cab & 7.5L Eng.: [Type 2]	
	U-Bolt Kit (Front)	UJ534-10		U-Joint (Front)Ⓢ	UJ331
	U-Joint (Center)Ⓢ	UJ354		<i>Brute Force Greaseable</i>	UJ232
	<i>Brute Force Greaseable</i>	UJ270		<i>Brute Force Non Greaseable</i>	UJ231
	<i>Brute Force Non Greaseable</i>	UJ254		(For Aluminum Drive Shaft)	UJ331C
	(For Aluminum Drive Shaft)	UJ354C		Clamp Kit (Front)	UJ331-10
	U-Joint (Rear)Ⓢ	UJ434		U-Joint (Center)Ⓢ	UJ331
	<i>Brute Force Greaseable</i>	UJ265		<i>Brute Force Greaseable</i>	UJ232
	<i>Brute Force Non Greaseable</i>	UJ264		<i>Brute Force Non Greaseable</i>	UJ231
	U-Bolt Kit (Rear)	UJ534-10		(For Aluminum Drive Shaft)	UJ331C
	1994-1992 F-350 w/ Crew Cab, Auto. Trans. & 7.3L Eng.: [Type 2]			Clamp Kit (Center)	UJ331-10
	U-Joint (Front)Ⓢ	UJ354		U-Joint (Rear)Ⓢ	UJ331
	<i>Brute Force Greaseable</i>	UJ270		<i>Brute Force Greaseable</i>	UJ232
	<i>Brute Force Non Greaseable</i>	UJ254		<i>Brute Force Non Greaseable</i>	UJ231
	(For Aluminum Drive Shaft)	UJ354C		(For Aluminum Drive Shaft)	UJ331C
	U-Joint (Center)Ⓢ	UJ354		Clamp Kit (Rear)	UJ331-10
	<i>Brute Force Greaseable</i>	UJ270		1994-1992 F-350 Cab & Chassis: [Type 2]	
	<i>Brute Force Non Greaseable</i>	UJ254		U-Joint (Front)Ⓢ	UJ331
	(For Aluminum Drive Shaft)	UJ354C		<i>Brute Force Greaseable</i>	UJ232
	U-Joint (Rear)Ⓢ	UJ434		<i>Brute Force Non Greaseable</i>	UJ231
	<i>Brute Force Greaseable</i>	UJ265		(For Aluminum Drive Shaft)	UJ331C
	<i>Brute Force Non Greaseable</i>	UJ264		Clamp Kit (Front)	UJ331-10
	U-Bolt Kit (Rear)	UJ534-10		U-Joint (Center)Ⓢ	UJ331
				<i>Brute Force Greaseable</i>	UJ232
				<i>Brute Force Non Greaseable</i>	UJ231
				(For Aluminum Drive Shaft)	UJ331C
				Clamp Kit (Center)	UJ331-10
				U-Joint (Rear)Ⓢ	UJ331
				<i>Brute Force Greaseable</i>	UJ232
				<i>Brute Force Non Greaseable</i>	UJ231
				(For Aluminum Drive Shaft)	UJ331C
				Clamp Kit (Rear)	UJ331-10

(Continued)

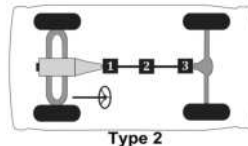

Passenger cars, light & medium trucks

Ford Truck 1 ton -- (Cont.)

MFG./YEAR	MODEL & LOCATION	PART NO.	MFG./YEAR	MODEL & LOCATION	PART NO.
Drive Shaft (2 W/D) (Cont.)			Drive Shaft (2 W/D) (Cont.)		
U-Joint (Cont.)			U-Joint (Cont.)		
1994-1989 F59 w/ 3 Joint Shaft: [Type 2]			1991 F-350 w/ Man. Trans. w/o 133" Wheel Base, 4.9L & 5.8L Eng.s.: [Type 2]		
U-Joint (Front)⊙		UJ330	U-Joint (Front)⊙		UJ331
Brute Force Greaseable		UJ295	Brute Force Greaseable		UJ232
(For Aluminum Drive Shaft)		UJ330C	Brute Force Non Greaseable		UJ231
Clamp Kit (Front)		UJ331-10	(For Aluminum Drive Shaft)		UJ331C
U-Joint (Center)⊙		UJ330	Clamp Kit (Front)		UJ331-10
Brute Force Greaseable		UJ295	U-Joint (Center)⊙		UJ331
(For Aluminum Drive Shaft)		UJ330C	Brute Force Greaseable		UJ232
Clamp Kit (Center)		UJ331-10	Brute Force Non Greaseable		UJ231
U-Joint (Rear)⊙		UJ330	(For Aluminum Drive Shaft)		UJ331C
Brute Force Greaseable		UJ295	Clamp Kit (Center)		UJ331-10
(For Aluminum Drive Shaft)		UJ330C	U-Joint (Rear)⊙		UJ331
Clamp Kit (Rear)		UJ331-10	Brute Force Greaseable		UJ232
1994-1989 F59 w/ 4 Joint Shaft: [Type 3]			Brute Force Non Greaseable		UJ231
U-Joint (Front)⊙		UJ330	(For Aluminum Drive Shaft)		UJ331C
Brute Force Greaseable		UJ295	Clamp Kit (Rear)		UJ331-10
(For Aluminum Drive Shaft)		UJ330C	1991 F-350 w/ 2 Joint Shaft & 3 Spd. Auto. Trans.: [Type 1]		
Clamp Kit (Front)		UJ331-10	U-Joint (Front)⊙		UJ354
U-Joint (Center; Front)⊙		UJ330	Brute Force Greaseable		UJ270
Brute Force Greaseable		UJ295	Brute Force Non Greaseable		UJ254
(For Aluminum Drive Shaft)		UJ330C	(For Aluminum Drive Shaft)		UJ354C
Clamp Kit (Center; Front)		UJ331-10	U-Joint (Rear)⊙		UJ434
U-Joint (Center; Rear)⊙		UJ330	Brute Force Greaseable		UJ265
Brute Force Greaseable		UJ295	Brute Force Non Greaseable		UJ264
(For Aluminum Drive Shaft)		UJ330C	U-Bolt Kit (Rear)		UJ534-10
Clamp Kit (Center; Rear)		UJ331-10	1991 F-350 w/ 3 Joint Shaft & 3 Spd. Auto. Trans.: [Type 2]		
U-Joint (Rear)⊙		UJ330	U-Joint (Front)⊙		UJ331
Brute Force Greaseable		UJ295	Brute Force Greaseable		UJ232
(For Aluminum Drive Shaft)		UJ330C	Brute Force Non Greaseable		UJ231
Clamp Kit (Rear)		UJ331-10	(For Aluminum Drive Shaft)		UJ331C
1991 F-350 w/ 133" Wheel Base, Man. Trans., 4.9L & 5.8L Eng.s.: [Type 2]			Clamp Kit (Front)		UJ331-10
U-Joint (Front)⊙		UJ434	U-Joint (Center)⊙		UJ331
Brute Force Greaseable		UJ265	Brute Force Greaseable		UJ232
Brute Force Non Greaseable		UJ264	Brute Force Non Greaseable		UJ231
U-Bolt Kit (Front)		UJ534-10	(For Aluminum Drive Shaft)		UJ331C
U-Joint (Center)⊙		UJ331	Clamp Kit (Center)		UJ331-10
Brute Force Greaseable		UJ232	U-Joint (Rear)⊙		UJ331
Brute Force Non Greaseable		UJ231	Brute Force Greaseable		UJ232
(For Aluminum Drive Shaft)		UJ331C	Brute Force Non Greaseable		UJ231
U-Joint (Rear)⊙		UJ331	(For Aluminum Drive Shaft)		UJ331C
Brute Force Greaseable		UJ232	Clamp Kit (Rear)		UJ331-10
Brute Force Non Greaseable		UJ231			
(For Aluminum Drive Shaft)		UJ331C			

(Continued)

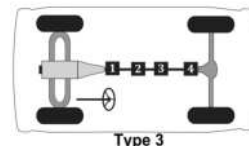
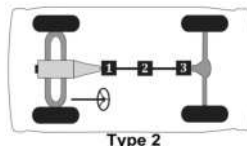
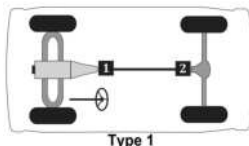

MFG./YEAR	MODEL & LOCATION	PART NO.	MFG./YEAR	MODEL & LOCATION	PART NO.
Drive Shaft (2 W/D) (Cont.)			Drive Shaft (2 W/D) (Cont.)		
U-Joint (Cont.)			U-Joint (Cont.)		
1991	F-350 w/ 3 Joint Shaft, 136" Wheel Base, 4 Spd. Auto. Trans. & 5.8L Eng.: [Type 2]		1991	F-350 w/ 3 Joint Shaft, 168" Wheel Base & 4 Spd. Auto. Trans.: [Type 2]	
	U-Joint (Front)Ⓢ	UJ434		U-Joint (Front)Ⓢ	UJ354
	<i>Brute Force Greaseable</i>	UJ265		<i>Brute Force Greaseable</i>	UJ270
	<i>Brute Force Non Greaseable</i>	UJ264		<i>Brute Force Non Greaseable</i>	UJ254
	U-Bolt Kit (Front)	UJ534-10		(For Aluminum Drive Shaft)	UJ354C
	U-Joint (Center)Ⓢ	UJ331		U-Joint (Center)Ⓢ	UJ354
	<i>Brute Force Greaseable</i>	UJ232		<i>Brute Force Greaseable</i>	UJ270
	<i>Brute Force Non Greaseable</i>	UJ231		<i>Brute Force Non Greaseable</i>	UJ254
	(For Aluminum Drive Shaft)	UJ331C		(For Aluminum Drive Shaft)	UJ354C
	Clamp Kit (Center)	UJ331-10		U-Joint (Rear)Ⓢ	UJ434
	U-Joint (Rear)Ⓢ	UJ331		<i>Brute Force Greaseable</i>	UJ265
	<i>Brute Force Greaseable</i>	UJ232		<i>Brute Force Non Greaseable</i>	UJ264
	<i>Brute Force Non Greaseable</i>	UJ231		U-Bolt Kit (Rear)	UJ534-10
	(For Aluminum Drive Shaft)	UJ331C	1990	F-350 w/ 133" Wheel Base, Man. Trans., 4.9L & 5.8L Eng.: [Type 2]	
	Clamp Kit (Rear)	UJ331-10		U-Joint (Front)Ⓢ	UJ434
1991	F-350 w/ 3 Joint Shaft, 136" Wheel Base, 4 Spd. Auto. Trans. & 7.3L & 7.5L Eng.: [Type 2]			<i>Brute Force Greaseable</i>	UJ265
	U-Joint (Front)Ⓢ	UJ331		<i>Brute Force Non Greaseable</i>	UJ264
	<i>Brute Force Greaseable</i>	UJ232		U-Bolt Kit (Front)	UJ534-10
	<i>Brute Force Non Greaseable</i>	UJ231		U-Joint (Center)Ⓢ	UJ354
	(For Aluminum Drive Shaft)	UJ331C		<i>Brute Force Greaseable</i>	UJ270
	Clamp Kit (Front)	UJ331-10		<i>Brute Force Non Greaseable</i>	UJ254
	U-Joint (Center)Ⓢ	UJ331		(For Aluminum Drive Shaft)	UJ354C
	<i>Brute Force Greaseable</i>	UJ232		U-Joint (Rear)Ⓢ	UJ434
	<i>Brute Force Non Greaseable</i>	UJ231		<i>Brute Force Greaseable</i>	UJ265
	(For Aluminum Drive Shaft)	UJ331C		<i>Brute Force Non Greaseable</i>	UJ264
	Clamp Kit (Center)	UJ331-10		U-Bolt Kit (Rear)	UJ534-10
	U-Joint (Rear)Ⓢ	UJ331	1990	F-350 w/ 136", 160" Wheel Base & Man. Trans.: [Type 2]	
	<i>Brute Force Greaseable</i>	UJ232		U-Joint (Front)Ⓢ	UJ434
	<i>Brute Force Non Greaseable</i>	UJ231		<i>Brute Force Greaseable</i>	UJ265
	(For Aluminum Drive Shaft)	UJ331C		<i>Brute Force Non Greaseable</i>	UJ264
	Clamp Kit (Rear)	UJ331-10		U-Bolt Kit (Front)	UJ534-10
1991	F-350 w/ 3 Joint Shaft, 155" & 160" Wheel Base & 4 Spd. Auto. Trans.: [Type 2]			U-Joint (Center)Ⓢ	UJ331
	U-Joint (Front)Ⓢ	UJ331		<i>Brute Force Greaseable</i>	UJ232
	<i>Brute Force Greaseable</i>	UJ232		<i>Brute Force Non Greaseable</i>	UJ231
	<i>Brute Force Non Greaseable</i>	UJ231		(For Aluminum Drive Shaft)	UJ331C
	(For Aluminum Drive Shaft)	UJ331C		U-Joint (Rear)Ⓢ	UJ331
	Clamp Kit (Front)	UJ331-10		<i>Brute Force Greaseable</i>	UJ232
	U-Joint (Center)Ⓢ	UJ331		<i>Brute Force Non Greaseable</i>	UJ231
	<i>Brute Force Greaseable</i>	UJ232		(For Aluminum Drive Shaft)	UJ331C
	<i>Brute Force Non Greaseable</i>	UJ231			
	(For Aluminum Drive Shaft)	UJ331C			
	Clamp Kit (Center)	UJ331-10			
	U-Joint (Rear)Ⓢ	UJ331			
	<i>Brute Force Greaseable</i>	UJ232			
	<i>Brute Force Non Greaseable</i>	UJ231			
	(For Aluminum Drive Shaft)	UJ331C			
	Clamp Kit (Rear)	UJ331-10			

(Continued)

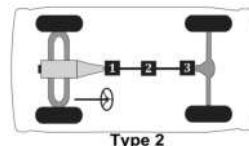

Type 2

Passenger cars, light & medium trucks

Ford Truck 1 ton -- (Cont.)

MFG./YEAR	MODEL & LOCATION	PART NO.	MFG./YEAR	MODEL & LOCATION	PART NO.
Drive Shaft (2 W/D) (Cont.)			Drive Shaft (2 W/D) (Cont.)		
U-Joint (Cont.)			U-Joint (Cont.)		
1990	F-350 w/ Man. Trans., 7.3L & 7.5L Eng.: [Type 2]		1990	F-350 w/ 160" Wheel Base, Auto. Trans. & 6 Cyl. Eng.: [Type 2]	
	U-Joint (Front) Ⓛ	UJ331		U-Joint (Front) Ⓛ	UJ434
	Brute Force Greaseable	UJ232		Brute Force Greaseable	UJ265
	Brute Force Non Greaseable	UJ231		Brute Force Non Greaseable	UJ264
	(For Aluminum Drive Shaft)	UJ331C		U-Bolt Kit (Front)	UJ534-10
	Clamp Kit (Front)	UJ331-10		U-Joint (Center) Ⓛ	UJ331
	U-Joint (Center) Ⓛ	UJ331		Brute Force Greaseable	UJ232
	Brute Force Greaseable	UJ232		Brute Force Non Greaseable	UJ231
	Brute Force Non Greaseable	UJ231		(For Aluminum Drive Shaft)	UJ331C
	(For Aluminum Drive Shaft)	UJ331C		U-Joint (Rear) Ⓛ	UJ331
	Clamp Kit (Center)	UJ331-10		Brute Force Greaseable	UJ232
	U-Joint (Rear) Ⓛ	UJ331		Brute Force Non Greaseable	UJ231
	Brute Force Greaseable	UJ232		(For Aluminum Drive Shaft)	UJ331C
	Brute Force Non Greaseable	UJ231		1990 F-350 w/ 160" Wheel Base, Auto.	
	(For Aluminum Drive Shaft)	UJ331C		Trans. & 8 Cyl. Eng.: [Type 2]	
	Clamp Kit (Rear)	UJ331-10		U-Joint (Front) Ⓛ	UJ331
1990	F-350 w/ 133" Wheel Base & Auto. Trans.: [Type 1]			Brute Force Greaseable	UJ232
	U-Joint (Front) Ⓛ	UJ354		Brute Force Non Greaseable	UJ231
	Brute Force Greaseable	UJ270		(For Aluminum Drive Shaft)	UJ331C
	Brute Force Non Greaseable	UJ254		Clamp Kit (Front)	UJ331-10
	(For Aluminum Drive Shaft)	UJ354C		U-Joint (Center) Ⓛ	UJ331
	U-Joint (Rear) Ⓛ	UJ434		Brute Force Greaseable	UJ232
	Brute Force Greaseable	UJ265		Brute Force Non Greaseable	UJ231
	Brute Force Non Greaseable	UJ264		(For Aluminum Drive Shaft)	UJ331C
	U-Bolt Kit (Rear)	UJ534-10		Clamp Kit (Center)	UJ331-10
1990	F-350 w/ 136", 155" Wheel Base & Auto. Trans.: [Type 2]			U-Joint (Rear) Ⓛ	UJ331
	U-Joint (Front) Ⓛ	UJ331		Brute Force Greaseable	UJ232
	Brute Force Greaseable	UJ232		Brute Force Non Greaseable	UJ231
	Brute Force Non Greaseable	UJ231		(For Aluminum Drive Shaft)	UJ331C
	(For Aluminum Drive Shaft)	UJ331C		Clamp Kit (Rear)	UJ331-10
	Clamp Kit (Front)	UJ331-10		1990 F-350 w/ 168" Wheel Base & Auto.	
	U-Joint (Center) Ⓛ	UJ331		Trans.: [Type 2]	
	Brute Force Greaseable	UJ232		U-Joint (Front) Ⓛ	UJ354
	Brute Force Non Greaseable	UJ231		Brute Force Greaseable	UJ270
	(For Aluminum Drive Shaft)	UJ331C		Brute Force Non Greaseable	UJ254
	Clamp Kit (Center)	UJ331-10		(For Aluminum Drive Shaft)	UJ354C
	U-Joint (Rear) Ⓛ	UJ331		U-Joint (Center) Ⓛ	UJ354
	Brute Force Greaseable	UJ232		Brute Force Greaseable	UJ270
	Brute Force Non Greaseable	UJ231		Brute Force Non Greaseable	UJ254
	(For Aluminum Drive Shaft)	UJ331C		(For Aluminum Drive Shaft)	UJ354C
	Clamp Kit (Rear)	UJ331-10		U-Joint (Rear) Ⓛ	UJ434
				Brute Force Greaseable	UJ265
				Brute Force Non Greaseable	UJ264
				U-Bolt Kit (Rear)	UJ534-10

(Continued)

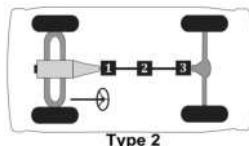
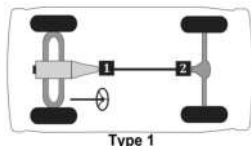

MFG./YEAR	MODEL & LOCATION	PART NO.	MFG./YEAR	MODEL & LOCATION	PART NO.
Drive Shaft (2 W/D) (Cont.)			Drive Shaft (2 W/D) (Cont.)		
U-Joint (Cont.)			U-Joint (Cont.)		
1989	F-350 w/ 3 Joint Shaft Exc. 5 Spd. Man. Trans.: [Type 2]		1989	F-350 w/ 5 Spd. Man. Trans., 7.3L & 7.5L Eng.: [Type 1]	
	U-Joint (Front)Ⓢ	UJ331		U-Joint (Front)Ⓢ	UJ331
	<i>Brute Force Greaseable</i>	UJ232		<i>Brute Force Greaseable</i>	UJ232
	<i>Brute Force Non Greaseable</i>	UJ231		<i>Brute Force Non Greaseable</i>	UJ231
	(For Aluminum Drive Shaft)	UJ331C		(For Aluminum Drive Shaft)	UJ331C
	Clamp Kit (Front)	UJ331-10		Clamp Kit (Front)	UJ331-10
	U-Joint (Center)Ⓢ	UJ331		U-Joint (Rear)Ⓢ	UJ331
	<i>Brute Force Greaseable</i>	UJ232		<i>Brute Force Greaseable</i>	UJ232
	<i>Brute Force Non Greaseable</i>	UJ231		<i>Brute Force Non Greaseable</i>	UJ231
	(For Aluminum Drive Shaft)	UJ331C		(For Aluminum Drive Shaft)	UJ331C
	Clamp Kit (Center)	UJ331-10		Clamp Kit (Rear)	UJ331-10
	U-Joint (Rear)Ⓢ	UJ331		1989-1987 F-350 w/ 2 Joint Shaft Exc. 5 Spd.	
	<i>Brute Force Greaseable</i>	UJ232		Man. Trans.: [Type 1]	
	<i>Brute Force Non Greaseable</i>	UJ231		U-Joint (Front)Ⓢ	UJ354
	(For Aluminum Drive Shaft)	UJ331C		<i>Brute Force Greaseable</i>	UJ270
	Clamp Kit (Rear)	UJ331-10		<i>Brute Force Non Greaseable</i>	UJ254
	1989 F-350 w/ 133" Wheel Base, 5 Spd.			(For Aluminum Drive Shaft)	UJ354C
	Man. Trans., 4.9L & 5.8L Eng.: [Type 1]			U-Joint (Rear)Ⓢ	UJ434
	U-Joint (Front)Ⓢ	UJ354		<i>Brute Force Greaseable</i>	UJ265
	<i>Brute Force Greaseable</i>	UJ270		<i>Brute Force Non Greaseable</i>	UJ264
	<i>Brute Force Non Greaseable</i>	UJ254		U-Bolt Kit (Rear)	UJ534-10
	(For Aluminum Drive Shaft)	UJ354C		1988 F-350 w/ 3 Joint Shaft & 5 Spd. Man.	
	U-Joint (Rear)Ⓢ	UJ434		Trans.: [Type 2]	
	<i>Brute Force Greaseable</i>	UJ265		U-Joint (Front)Ⓢ	UJ434
	<i>Brute Force Non Greaseable</i>	UJ264		<i>Brute Force Greaseable</i>	UJ265
	U-Bolt Kit (Rear)	UJ534-10		<i>Brute Force Non Greaseable</i>	UJ264
	1989 F-350 w/ 136", 160", 168" Wheel Base,			U-Bolt Kit (Front)	UJ534-10
	5 Spd. Man. Trans., 4.9L & 5.8L Eng.: [Type 2]			U-Joint (Center)Ⓢ	UJ354
	U-Joint (Front)Ⓢ	UJ434		<i>Brute Force Greaseable</i>	UJ270
	<i>Brute Force Greaseable</i>	UJ265		<i>Brute Force Non Greaseable</i>	UJ254
	<i>Brute Force Non Greaseable</i>	UJ264		(For Aluminum Drive Shaft)	UJ354C
	U-Bolt Kit (Front)	UJ534-10		U-Joint (Rear)Ⓢ	UJ434
	U-Joint (Center)Ⓢ	UJ331		<i>Brute Force Greaseable</i>	UJ265
	<i>Brute Force Greaseable</i>	UJ232		<i>Brute Force Non Greaseable</i>	UJ264
	<i>Brute Force Non Greaseable</i>	UJ231		U-Bolt Kit (Rear)	UJ534-10
	(For Aluminum Drive Shaft)	UJ331C			(Continued)
	Clamp Kit (Center)	UJ331-10			
	U-Joint (Rear)Ⓢ	UJ331			
	<i>Brute Force Greaseable</i>	UJ232			
	<i>Brute Force Non Greaseable</i>	UJ231			
	(For Aluminum Drive Shaft)	UJ331C			
	Clamp Kit (Rear)	UJ331-10			

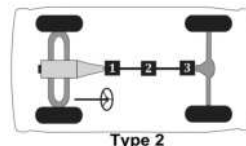
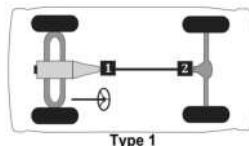

Passenger cars, light & medium trucks

Ford Truck 1 ton -- (Cont.)

MFG./YEAR	MODEL & LOCATION	PART NO.	MFG./YEAR	MODEL & LOCATION	PART NO.
Drive Shaft (2 W/D) (Cont.)			Drive Shaft (2 W/D) (Cont.)		
U-Joint (Cont.)			U-Joint (Cont.)		
1988	F-350 w/ 3 Joint Shaft, 7.3L & 7.5L Eng. Exc. 5 Spd. Man. Trans.: [Type 2]		1987	F-350 w/ 3 Joint Shaft & HD 5 Spd. Man. Trans.: [Type 2]	
U-Joint (Front)Ⓛ		UJ331	U-Joint (Front)Ⓛ		UJ331
<i>Brute Force Greaseable</i>		UJ232	<i>Brute Force Greaseable</i>		UJ232
<i>Brute Force Non Greaseable</i>		UJ231	<i>Brute Force Non Greaseable</i>		UJ231
(For Aluminum Drive Shaft)		UJ331C	(For Aluminum Drive Shaft)		UJ331C
Clamp Kit (Front)		UJ331-10	Clamp Kit (Front)		UJ331-10
U-Joint (Center)Ⓢ		UJ331	U-Joint (Center)Ⓢ		UJ331
<i>Brute Force Greaseable</i>		UJ232	<i>Brute Force Greaseable</i>		UJ232
<i>Brute Force Non Greaseable</i>		UJ231	<i>Brute Force Non Greaseable</i>		UJ231
(For Aluminum Drive Shaft)		UJ331C	(For Aluminum Drive Shaft)		UJ331C
Clamp Kit (Center)		UJ331-10	Clamp Kit (Center)		UJ331-10
U-Joint (Rear)Ⓢ		UJ331	U-Joint (Rear)Ⓢ		UJ331
<i>Brute Force Greaseable</i>		UJ232	<i>Brute Force Greaseable</i>		UJ232
<i>Brute Force Non Greaseable</i>		UJ231	<i>Brute Force Non Greaseable</i>		UJ231
(For Aluminum Drive Shaft)		UJ331C	(For Aluminum Drive Shaft)		UJ331C
Clamp Kit (Rear)		UJ331-10	Clamp Kit (Rear)		UJ331-10
1988-1987 F-350 w/ 2 Joint Shaft & 5 Spd. Man. Trans.: [Type 1]			1987 F-350 w/ 3 Joint Shaft & Auto. Trans.: [Type 2]		
U-Joint (Front)Ⓛ		UJ331	U-Joint (Front)Ⓛ		UJ354
<i>Brute Force Greaseable</i>		UJ232	<i>Brute Force Greaseable</i>		UJ270
<i>Brute Force Non Greaseable</i>		UJ231	<i>Brute Force Non Greaseable</i>		UJ254
(For Aluminum Drive Shaft)		UJ331C	(For Aluminum Drive Shaft)		UJ354C
Clamp Kit (Front)		UJ331-10	U-Joint (Center)Ⓢ		UJ354
U-Joint (Rear)Ⓢ		UJ331	<i>Brute Force Greaseable</i>		UJ270
<i>Brute Force Greaseable</i>		UJ232	<i>Brute Force Non Greaseable</i>		UJ254
<i>Brute Force Non Greaseable</i>		UJ231	(For Aluminum Drive Shaft)		UJ354C
(For Aluminum Drive Shaft)		UJ331C	U-Joint (Rear)Ⓢ		UJ434
Clamp Kit (Rear)		UJ331-10	<i>Brute Force Greaseable</i>		UJ265
1987 F-350 w/ 3 Joint Shaft & Man. Trans. Exc. HD Man. Trans.: [Type 2]			<i>Brute Force Non Greaseable</i>		UJ264
U-Joint (Front)Ⓛ		UJ434	U-Bolt Kit (Rear)		UJ534-10
<i>Brute Force Greaseable</i>		UJ265	1986-1984 F-350 w/ 3 Joint Shaft & Auto. Trans.: [Type 2]		
<i>Brute Force Non Greaseable</i>		UJ264	U-Joint (Front)Ⓛ		UJ354
U-Bolt Kit (Front)		UJ534-10	<i>Brute Force Greaseable</i>		UJ270
U-Joint (Center)Ⓢ		UJ354	<i>Brute Force Non Greaseable</i>		UJ254
<i>Brute Force Greaseable</i>		UJ270	(For Aluminum Drive Shaft)		UJ354C
<i>Brute Force Non Greaseable</i>		UJ254	U-Joint (Center)Ⓢ		UJ354
(For Aluminum Drive Shaft)		UJ354C	<i>Brute Force Greaseable</i>		UJ270
U-Joint (Rear)Ⓢ		UJ434	<i>Brute Force Non Greaseable</i>		UJ254
<i>Brute Force Greaseable</i>		UJ265	(For Aluminum Drive Shaft)		UJ354C
<i>Brute Force Non Greaseable</i>		UJ264	U-Joint (Rear)Ⓢ		UJ434
U-Bolt Kit (Rear)		UJ534-10	<i>Brute Force Greaseable</i>		UJ265
			<i>Brute Force Non Greaseable</i>		UJ264
			U-Bolt Kit (Rear)		UJ534-10

(Continued)

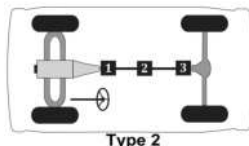
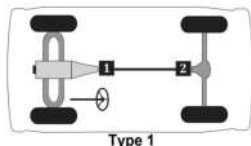

MFG./YEAR	MODEL & LOCATION	PART NO.	MFG./YEAR	MODEL & LOCATION	PART NO.
Drive Shaft (2 W/D) (Cont.)			Drive Shaft (2 W/D) (Cont.)		
U-Joint (Cont.)			U-Joint (Cont.)		
1986-1984 F-350 w/ 3 Joint Shaft & Man. Trans.:			1979 F-350 w/ 1.063" Dia. Brg. Cap: [Type		
[Type 2]			2]		
U-Joint (Front)Ⓢ		UJ434	U-Joint (Front)Ⓢ		UJ354
<i>Brute Force Greaseable</i>		UJ265	<i>Brute Force Greaseable</i>		UJ270
<i>Brute Force Non Greaseable</i>		UJ264	<i>Brute Force Non Greaseable</i>		UJ254
U-Bolt Kit (Front)		UJ534-10	(For Aluminum Drive Shaft)		UJ354C
U-Joint (Center)Ⓢ		UJ354	U-Joint (Center)Ⓢ		UJ354
<i>Brute Force Greaseable</i>		UJ270	<i>Brute Force Greaseable</i>		UJ270
<i>Brute Force Non Greaseable</i>		UJ254	<i>Brute Force Non Greaseable</i>		UJ254
(For Aluminum Drive Shaft)		UJ354C	(For Aluminum Drive Shaft)		UJ354C
U-Joint (Rear)Ⓢ		UJ434	U-Joint (Rear)Ⓢ		UJ434
<i>Brute Force Greaseable</i>		UJ265	<i>Brute Force Greaseable</i>		UJ265
<i>Brute Force Non Greaseable</i>		UJ264	<i>Brute Force Non Greaseable</i>		UJ264
U-Bolt Kit (Rear)		UJ534-10	U-Bolt Kit (Rear)		UJ534-10
1986-1980 F-350 w/ 2 Joint Shaft: [Type 1]			1979 F-350 w/ 1.188" Dia. Brg. Cap: [Type		
U-Joint (Front)Ⓢ			2]		
<i>Brute Force Greaseable</i>		UJ270	U-Joint (Front)Ⓢ		UJ354
<i>Brute Force Non Greaseable</i>		UJ254	<i>Brute Force Greaseable</i>		UJ270
(For Aluminum Drive Shaft)		UJ354C	<i>Brute Force Non Greaseable</i>		UJ254
U-Joint (Rear)Ⓢ		UJ434	(For Aluminum Drive Shaft)		UJ354C
<i>Brute Force Greaseable</i>		UJ265	U-Joint (Center)Ⓢ		UJ331
<i>Brute Force Non Greaseable</i>		UJ264	<i>Brute Force Greaseable</i>		UJ232
U-Bolt Kit (Rear)		UJ534-10	<i>Brute Force Non Greaseable</i>		UJ231
1983-1982 F-350 w/ 3 Joint Shaft: [Type 2]			(For Aluminum Drive Shaft)		UJ331C
U-Joint (Front)Ⓢ		UJ434	U-Joint (Rear)Ⓢ		UJ331
<i>Brute Force Greaseable</i>		UJ265	<i>Brute Force Greaseable</i>		UJ232
<i>Brute Force Non Greaseable</i>		UJ264	<i>Brute Force Non Greaseable</i>		UJ231
U-Bolt Kit (Front)		UJ534-10	(For Aluminum Drive Shaft)		UJ331C
U-Joint (Front)Ⓢ		UJ354	U-Joint (Rear)Ⓢ		UJ331
<i>Brute Force Greaseable</i>		UJ270	<i>Brute Force Greaseable</i>		UJ232
<i>Brute Force Non Greaseable</i>		UJ254	<i>Brute Force Non Greaseable</i>		UJ231
(For Aluminum Drive Shaft)		UJ354C	(For Aluminum Drive Shaft)		UJ331C
U-Joint (Center)Ⓢ		UJ354	1978-1977 F-350 w/ 1.063" Dia. Brg. Cap, 300, 302		
<i>Brute Force Greaseable</i>		UJ270	& 351 Engs.: [Type 2]		
<i>Brute Force Non Greaseable</i>		UJ254	U-Joint (Front)Ⓢ		UJ354
(For Aluminum Drive Shaft)		UJ354C	<i>Brute Force Greaseable</i>		UJ270
U-Joint (Center)Ⓢ		UJ354	<i>Brute Force Non Greaseable</i>		UJ254
<i>Brute Force Greaseable</i>		UJ270	(For Aluminum Drive Shaft)		UJ354C
<i>Brute Force Non Greaseable</i>		UJ254	U-Joint (Center)Ⓢ		UJ354
(For Aluminum Drive Shaft)		UJ354C	<i>Brute Force Greaseable</i>		UJ270
U-Joint (Rear)Ⓢ		UJ434	<i>Brute Force Non Greaseable</i>		UJ254
<i>Brute Force Greaseable</i>		UJ265	(For Aluminum Drive Shaft)		UJ354C
<i>Brute Force Non Greaseable</i>		UJ264	U-Joint (Rear)Ⓢ		UJ354
U-Bolt Kit (Rear)		UJ534-10	<i>Brute Force Greaseable</i>		UJ270
1981-1980 F-350 w/ 3 Joint Shaft: [Type 2]			<i>Brute Force Non Greaseable</i>		UJ254
U-Joint (Front)Ⓢ		UJ354	(For Aluminum Drive Shaft)		UJ354C
<i>Brute Force Greaseable</i>		UJ270	(Continued)		
<i>Brute Force Non Greaseable</i>		UJ254			
(For Aluminum Drive Shaft)		UJ354C			
U-Joint (Center)Ⓢ		UJ354			
<i>Brute Force Greaseable</i>		UJ270			
<i>Brute Force Non Greaseable</i>		UJ254			
(For Aluminum Drive Shaft)		UJ354C			
U-Joint (Rear)Ⓢ		UJ434			
<i>Brute Force Greaseable</i>		UJ265			
<i>Brute Force Non Greaseable</i>		UJ264			
U-Bolt Kit (Rear)		UJ534-10			

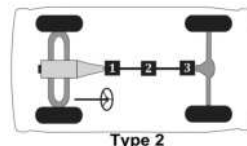
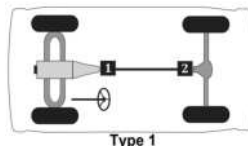

Passenger cars, light & medium trucks

Ford Truck 1 ton -- (Cont.)

MFG./YEAR	MODEL & LOCATION	PART NO.	MFG./YEAR	MODEL & LOCATION	PART NO.
Drive Shaft (2 W/D) (Cont.)			Drive Shaft (2 W/D) (Cont.)		
U-Joint (Cont.)			U-Joint (Cont.)		
1978-1977 F-350 w/ 1.188" Dia. Brg. Cap, 300, 302 & 351 Eng.s.: [Type 2]			1976-1975 F-350 w/o 155" Wheel Base, 390 & 460 Eng.s.: [Type 2]		
U-Joint (Front)Ⓛ		UJ354	U-Joint (Front)Ⓛ		UJ354
Brute Force Greaseable		UJ270	Brute Force Greaseable		UJ270
Brute Force Non Greaseable		UJ254	Brute Force Non Greaseable		UJ254
(For Aluminum Drive Shaft)		UJ354C	(For Aluminum Drive Shaft)		UJ354C
U-Joint (Center)Ⓟ		UJ331	U-Joint (Center)Ⓟ		UJ354
Brute Force Greaseable		UJ232	Brute Force Greaseable		UJ270
Brute Force Non Greaseable		UJ231	Brute Force Non Greaseable		UJ254
(For Aluminum Drive Shaft)		UJ331C	(For Aluminum Drive Shaft)		UJ354C
U-Joint (Rear)Ⓢ		UJ331	U-Joint (Rear)Ⓢ		UJ354
Brute Force Greaseable		UJ232	Brute Force Greaseable		UJ270
Brute Force Non Greaseable		UJ231	Brute Force Non Greaseable		UJ254
(For Aluminum Drive Shaft)		UJ331C	(For Aluminum Drive Shaft)		UJ354C
1978-1977 F-350 w/ Auto.Trans., 400 & 460 Eng.s.			1976-1975 F-350 w/ 390 & 460 Eng.s. Exc. 155"		
[Type 2]			Wheel Base: [Type 2]		
U-Joint (Front)Ⓛ		UJ354	U-Joint (Front)Ⓛ		UJ331
Brute Force Greaseable		UJ270	Brute Force Greaseable		UJ232
Brute Force Non Greaseable		UJ254	Brute Force Non Greaseable		UJ231
(For Aluminum Drive Shaft)		UJ354C	(For Aluminum Drive Shaft)		UJ331C
U-Joint (Center)Ⓟ		UJ331	U-Joint (Center)Ⓟ		UJ331
Brute Force Greaseable		UJ232	Brute Force Greaseable		UJ232
Brute Force Non Greaseable		UJ231	Brute Force Non Greaseable		UJ231
(For Aluminum Drive Shaft)		UJ331C	(For Aluminum Drive Shaft)		UJ331C
U-Joint (Rear)Ⓢ		UJ331	U-Joint (Rear)Ⓢ		UJ331
Brute Force Greaseable		UJ232	Brute Force Greaseable		UJ232
Brute Force Non Greaseable		UJ231	Brute Force Non Greaseable		UJ231
(For Aluminum Drive Shaft)		UJ331C	(For Aluminum Drive Shaft)		UJ331C
1978-1977 F-350 w/ Man. Trans., 400 & 460 Eng.s.: [Type 2]			1976-1975 F-350 w/ 155" Wheel Base: [Type 2]		
U-Joint (Front)Ⓛ		UJ331	U-Joint (Front)Ⓛ		UJ369
Brute Force Greaseable		UJ232	Brute Force Greaseable		UJ280
Brute Force Non Greaseable		UJ231	Brute Force Non Greaseable		UJ269
(For Aluminum Drive Shaft)		UJ331C	(For Aluminum Drive Shaft)		UJ369C
U-Joint (Center)Ⓟ		UJ331	U-Joint (Center)Ⓟ		UJ331
Brute Force Greaseable		UJ232	Brute Force Greaseable		UJ232
Brute Force Non Greaseable		UJ231	Brute Force Non Greaseable		UJ231
(For Aluminum Drive Shaft)		UJ331C	(For Aluminum Drive Shaft)		UJ331C
U-Joint (Rear)Ⓢ		UJ331	U-Joint (Rear)Ⓢ		UJ331
Brute Force Greaseable		UJ232	Brute Force Greaseable		UJ232
Brute Force Non Greaseable		UJ231	Brute Force Non Greaseable		UJ231
(For Aluminum Drive Shaft)		UJ331C	(For Aluminum Drive Shaft)		UJ331C

(Continued)

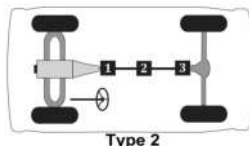

MFG./YEAR	MODEL & LOCATION	PART NO.	MFG./YEAR	MODEL & LOCATION	PART NO.
Drive Shaft (2 W/D) (Cont.)			Drive Shaft (4 W/D)		
U-Joint (Cont.)			U-Joint		
1974-1968 F-350 w/ 390 & 460 Eng.s.: [Type 2]			2020-2011 F-350 Super Duty w/ Single Rear Whls., 2 Joint Driveshaft & Narrow Frt. Axle: [Type 28]		
U-Joint (Front)Ⓢ		UJ354	U-Joint (Frt. Shaft; Frt.)Ⓢ		UJ331
Brute Force Greaseable		UJ270	Brute Force Greaseable		UJ232
Brute Force Non Greaseable		UJ254	Brute Force Non Greaseable		UJ231
(For Aluminum Drive Shaft)		UJ354C	(For Aluminum Drive Shaft)		UJ331C
U-Joint (Center)Ⓢ		UJ331	Clamp Kit (Frt. Shaft; Frt.)		UJ331-10
Brute Force Greaseable		UJ232	U-Joint (Rr. Shaft; Frt.)Ⓢ		UJ330
Brute Force Non Greaseable		UJ231	Brute Force Greaseable		UJ295
(For Aluminum Drive Shaft)		UJ331C	(For Aluminum Drive Shaft)		UJ330C
U-Joint (Rear)Ⓢ		UJ331	Clamp Kit (Rr. Shaft; Frt.)		UJ331-10
Brute Force Greaseable		UJ232	U-Joint (Rr. Shaft; Rr.)Ⓢ		UJ330
Brute Force Non Greaseable		UJ231	Brute Force Greaseable		UJ295
(For Aluminum Drive Shaft)		UJ331C	(For Aluminum Drive Shaft)		UJ330C
1974-1967 F-350 w/o 390 & 460 Eng.s.: [Type 2]			Clamp Kit (Rr. Shaft; Rr.)		UJ331-10
U-Joint (Front)Ⓢ		UJ369	U-Joint (Wheel Joint)Ⓢ	[2]	UJ374
Brute Force Greaseable		UJ280	Brute Force Non Greaseable		UJ374BF
Brute Force Non Greaseable		UJ269	2020-2011 F-350 Super Duty w/ Single Rear Whls., 3 Joint Driveshaft & Narrow Frt. Axle: [Type 29]		
(For Aluminum Drive Shaft)		UJ369C	U-Joint (Frt. Shaft; Frt.)Ⓢ		UJ331
U-Joint (Center)Ⓢ		UJ353	Brute Force Greaseable		UJ232
Brute Force Greaseable		UJ275	Brute Force Non Greaseable		UJ231
U-Joint (Rear)Ⓢ		UJ353	(For Aluminum Drive Shaft)		UJ331C
Brute Force Greaseable		UJ275	Clamp Kit (Frt. Shaft; Frt.)		UJ331-10
1966-1953 F-350 w/ 2 Joint Shaft: [Type 1]			U-Joint (Rr. Shaft; Frt.)Ⓢ		UJ330
U-Joint (Front)Ⓢ		UJ369	Brute Force Greaseable		UJ295
Brute Force Greaseable		UJ280	(For Aluminum Drive Shaft)		UJ330C
Brute Force Non Greaseable		UJ269	Clamp Kit (Rr. Shaft; Frt.)		UJ331-10
(For Aluminum Drive Shaft)		UJ369C	U-Joint (Rr. Shaft; Ctr.)Ⓢ		UJ330
U-Bolt Kit (Front)		UJ329-10	Brute Force Greaseable		UJ295
U-Joint (Rear)Ⓢ		UJ369	(For Aluminum Drive Shaft)		UJ330C
Brute Force Greaseable		UJ280	Clamp Kit (Rr. Shaft; Ctr.)		UJ331-10
Brute Force Non Greaseable		UJ269	U-Joint (Rr. Shaft; Rr.)Ⓢ		UJ330
(For Aluminum Drive Shaft)		UJ369C	Brute Force Greaseable		UJ295
U-Bolt Kit (Rear)		UJ329-10	(For Aluminum Drive Shaft)		UJ330C
1966-1953 F-350 w/ 3 Joint Shaft: [Type 2]			Clamp Kit (Rr. Shaft; Rr.)		UJ331-10
U-Joint (Front)Ⓢ		UJ369	U-Joint (Wheel Joint)Ⓢ	[2]	UJ374
Brute Force Greaseable		UJ280	Brute Force Non Greaseable		UJ374BF
Brute Force Non Greaseable		UJ269			(Continued)
(For Aluminum Drive Shaft)		UJ369C			
U-Bolt Kit (Front)		UJ329-10			
U-Joint (Center)Ⓢ		UJ369			
Brute Force Greaseable		UJ280			
Brute Force Non Greaseable		UJ269			
(For Aluminum Drive Shaft)		UJ369C			
U-Bolt Kit (Center)		UJ329-10			
U-Joint (Rear)Ⓢ		UJ369			
Brute Force Greaseable		UJ280			
Brute Force Non Greaseable		UJ269			
(For Aluminum Drive Shaft)		UJ369C			
U-Bolt Kit (Rear)		UJ329-10			

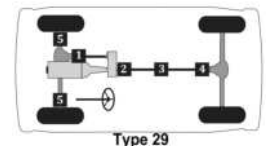
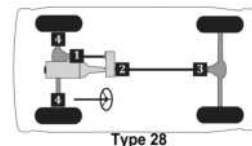
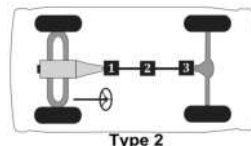
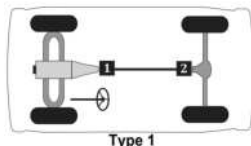

Passenger cars, light & medium trucks

Ford Truck 1 ton -- (Cont.)

MFG./YEAR	MODEL & LOCATION	PART NO.	MFG./YEAR	MODEL & LOCATION	PART NO.
Drive Shaft (4 W/D) (Cont.)			Drive Shaft (4 W/D) (Cont.)		
U-Joint (Cont.)			U-Joint (Cont.)		
2020-2011 F-350 Super Duty w/ Dual Rear Whls., 2 Joint Driveshaft & Narrow Frt. Axle:			2020-2011 F-350 Super Duty w/ Single Rear Whls., 3 Joint Driveshaft & Wide Frt. Axle: [Type 29]		
[Type 28]			[Type 29]		
U-Joint (Frt. Shaft; Frt.)ⓐ		UJ331	U-Joint (Frt. Shaft; Frt.)ⓐ		UJ331
Brute Force Greaseable		UJ232	Brute Force Greaseable		UJ232
Brute Force Non Greaseable		UJ231	Brute Force Non Greaseable		UJ231
(For Aluminum Drive Shaft)		UJ331C	(For Aluminum Drive Shaft)		UJ331C
Clamp Kit (Frt. Shaft; Frt.)		UJ331-10	Clamp Kit (Frt. Shaft; Frt.)		UJ331-10
U-Joint (Rr. Shaft; Frt.)ⓑ		UJ351	U-Joint (Rr. Shaft; Frt.)ⓑ		UJ330
(For Aluminum Drive Shaft)		UJ351C	Brute Force Greaseable		UJ295
Brute Force Non Greaseable		UJ351BF	(For Aluminum Drive Shaft)		UJ330C
U-Joint (Rr. Shaft; Rr.)ⓐ		UJ351	Clamp Kit (Rr. Shaft; Frt.)		UJ331-10
(For Aluminum Drive Shaft)		UJ351C	U-Joint (Rr. Shaft; Ctr.)ⓑ		UJ330
Brute Force Non Greaseable		UJ351BF	Brute Force Greaseable		UJ295
U-Joint (Wheel Joint)ⓐ	[2]	UJ374	(For Aluminum Drive Shaft)		UJ330C
Brute Force Non Greaseable		UJ374BF	Clamp Kit (Rr. Shaft; Ctr.)		UJ331-10
2020-2011 F-350 Super Duty w/ Dual Rear Whls., 3 Joint Driveshaft & Narrow Frt. Axle:			U-Joint (Rr. Shaft; Rr.)ⓐ		UJ330
[Type 29]			Brute Force Greaseable		UJ295
U-Joint (Frt. Shaft; Frt.)ⓐ		UJ331	(For Aluminum Drive Shaft)		UJ330C
Brute Force Greaseable		UJ232	Clamp Kit (Rr. Shaft; Rr.)		UJ331-10
Brute Force Non Greaseable		UJ231	U-Joint (Wheel Joint)ⓑ	[2]	UJ424
(For Aluminum Drive Shaft)		UJ331C	2020-2011 F-350 Super Duty w/ Dual Rear Whls., 2 Joint Driveshaft & Wide Frt. Axle:		
Clamp Kit (Frt. Shaft; Frt.)		UJ331-10	[Type 28]		
U-Joint (Rr. Shaft; Frt.)ⓑ		UJ351	U-Joint (Frt. Shaft; Frt.)ⓐ		UJ331
(For Aluminum Drive Shaft)		UJ351C	Brute Force Greaseable		UJ232
Brute Force Non Greaseable		UJ351BF	Brute Force Non Greaseable		UJ231
U-Joint (Rr. Shaft; Ctr.)ⓑ		UJ351	(For Aluminum Drive Shaft)		UJ331C
(For Aluminum Drive Shaft)		UJ351C	Clamp Kit (Frt. Shaft; Frt.)		UJ331-10
Brute Force Non Greaseable		UJ351BF	U-Joint (Rr. Shaft; Frt.)ⓑ		UJ351
U-Joint (Rr. Shaft; Rr.)ⓐ		UJ351	(For Aluminum Drive Shaft)		UJ351C
(For Aluminum Drive Shaft)		UJ351C	Brute Force Non Greaseable		UJ351BF
Brute Force Non Greaseable		UJ351BF	U-Joint (Rr. Shaft; Rr.)ⓑ		UJ351
U-Joint (Rr. Shaft; Rr.)ⓐ		UJ351	(For Aluminum Drive Shaft)		UJ351C
(For Aluminum Drive Shaft)		UJ351C	Brute Force Non Greaseable		UJ351BF
Brute Force Non Greaseable		UJ351BF	U-Joint (Wheel Joint)ⓐ	[2]	UJ424
U-Joint (Wheel Joint)ⓑ	[2]	UJ374			(Continued)
Brute Force Non Greaseable		UJ374BF			
2020-2011 F-350 Super Duty w/ Single Rear Whls., 2 Joint Driveshaft & Wide Frt. Axle: [Type 28]					
U-Joint (Frt. Shaft; Frt.)ⓐ		UJ331			
Brute Force Greaseable		UJ232			
Brute Force Non Greaseable		UJ231			
(For Aluminum Drive Shaft)		UJ331C			
Clamp Kit (Frt. Shaft; Frt.)		UJ331-10			
U-Joint (Rr. Shaft; Frt.)ⓑ		UJ330			
Brute Force Greaseable		UJ295			
(For Aluminum Drive Shaft)		UJ330C			
Clamp Kit (Rr. Shaft; Frt.)		UJ331-10			
U-Joint (Rr. Shaft; Rr.)ⓑ		UJ330			
Brute Force Greaseable		UJ295			
(For Aluminum Drive Shaft)		UJ330C			
Clamp Kit (Rr. Shaft; Rr.)		UJ331-10			
U-Joint (Wheel Joint)ⓐ	[2]	UJ424			

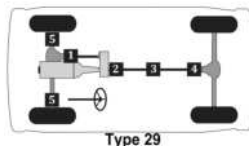
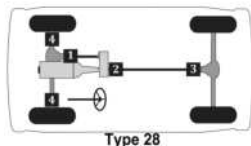

MFG./YEAR	MODEL & LOCATION	PART NO.	MFG./YEAR	MODEL & LOCATION	PART NO.
Drive Shaft (4 W/D) (Cont.)			Drive Shaft (4 W/D) (Cont.)		
U-Joint (Cont.)			U-Joint (Cont.)		
2020-2011 F-350 Super Duty w/ Dual Rear Whls., 3 Joint Driveshaft & Wide Frt. Axle: [Type 29]			2010-2009 F-350 Super Duty w/ Single Rear Whls. & 2 Joint Driveshaft: [Type 28]		
U-Joint (Frt. Shaft; Frt.) ① UJ331 <i>Brute Force Greaseable</i> UJ232 <i>Brute Force Non Greaseable</i> UJ231 (For Aluminum Drive Shaft) UJ331C Clamp Kit (Frt. Shaft; Frt.) UJ331-10 U-Joint (Rr. Shaft; Frt.) ② UJ351 (For Aluminum Drive Shaft) UJ351C <i>Brute Force Non Greaseable</i> UJ351BF U-Joint (Rr. Shaft; Ctr.) ③ UJ351 (For Aluminum Drive Shaft) UJ351C <i>Brute Force Non Greaseable</i> UJ351BF U-Joint (Rr. Shaft; Rr.) ④ UJ351 (For Aluminum Drive Shaft) UJ351C <i>Brute Force Non Greaseable</i> UJ351BF U-Joint (Wheel Joint) ⑤ [2] UJ424			U-Joint (Frt. Shaft; Frt.) ① UJ331 <i>Brute Force Greaseable</i> UJ232 <i>Brute Force Non Greaseable</i> UJ231 (For Aluminum Drive Shaft) UJ331C Clamp Kit (Frt. Shaft; Frt.) UJ331-10 U-Joint (Rr. Shaft; Frt.) ② UJ330 <i>Brute Force Greaseable</i> UJ295 (For Aluminum Drive Shaft) UJ330C Clamp Kit (Rr. Shaft; Frt.) UJ331-10 U-Joint (Rr. Shaft; Rr.) ③ UJ330 <i>Brute Force Greaseable</i> UJ295 (For Aluminum Drive Shaft) UJ330C Clamp Kit (Rr. Shaft; Rr.) UJ331-10 U-Joint (Wheel Joint) ⑤ [2] UJ374 <i>Brute Force Non Greaseable</i> UJ374BF 2010-2009 F-350 Super Duty w/ Single Rear Whls. & 3 Joint Driveshaft: [Type 29] U-Joint (Frt. Shaft; Frt.) ① UJ331 <i>Brute Force Greaseable</i> UJ232 <i>Brute Force Non Greaseable</i> UJ231 (For Aluminum Drive Shaft) UJ331C Clamp Kit (Frt. Shaft; Frt.) UJ331-10 U-Joint (Rr. Shaft; Frt.) ② UJ330 <i>Brute Force Greaseable</i> UJ295 (For Aluminum Drive Shaft) UJ330C Clamp Kit (Rr. Shaft; Frt.) UJ331-10 U-Joint (Rr. Shaft; Ctr.) ③ UJ330 <i>Brute Force Greaseable</i> UJ295 (For Aluminum Drive Shaft) UJ330C Clamp Kit (Rr. Shaft; Ctr.) UJ331-10 U-Joint (Rr. Shaft; Rr.) ④ UJ330 <i>Brute Force Greaseable</i> UJ295 (For Aluminum Drive Shaft) UJ330C Clamp Kit (Rr. Shaft; Rr.) UJ331-10 U-Joint (Wheel Joint) ⑤ [2] UJ374 <i>Brute Force Non Greaseable</i> UJ374BF		
2011-2009 F-350 Super Duty w/ CV Driveshaft Exc. Cab & Chassis: [Type 28]					
U-Joint (Frt. Shaft; Frt.) ① UJ331 <i>Brute Force Greaseable</i> UJ232 <i>Brute Force Non Greaseable</i> UJ231 (For Aluminum Drive Shaft) UJ331C Clamp Kit (Frt. Shaft; Frt.) UJ331-10 U-Joint (Rr. Shaft; Frt.) ② [2] UJ331 <i>Brute Force Greaseable</i> UJ232 <i>Brute Force Non Greaseable</i> UJ231 (For Aluminum Drive Shaft) UJ331C Clamp Kit (Rr. Shaft; Frt.) UJ331-10 U-Joint (Rr. Shaft; Rr.) ③ UJ330 <i>Brute Force Greaseable</i> UJ295 (For Aluminum Drive Shaft) UJ330C Clamp Kit (Rr. Shaft; Rr.) UJ331-10 U-Joint (Wheel Joint) ⑤ [2] UJ374 <i>Brute Force Non Greaseable</i> UJ374BF					

(Continued)

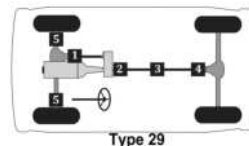
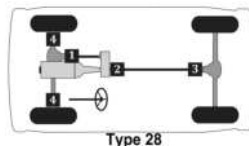

Passenger cars, light & medium trucks

Ford Truck 1 ton -- (Cont.)

MFG./YEAR	MODEL & LOCATION	PART NO.	MFG./YEAR	MODEL & LOCATION	PART NO.
Drive Shaft (4 W/D) (Cont.)			Drive Shaft (4 W/D) (Cont.)		
U-Joint (Cont.)			U-Joint (Cont.)		
2010-2009 F-350 Super Duty w/ Dual Rear Whls. & 2 Joint Driveshaft: [Type 28]			2008-2007 F-350 Super Duty Cab & Chassis w/ 3 Joint Shaft: [Type 29]		
U-Joint (Fr. Shaft; Frt.) [⊙]		UJ331	U-Joint (Fr. Shaft; Frt.) [⊙]		UJ331
Brute Force Greaseable		UJ232	Brute Force Greaseable		UJ232
Brute Force Non Greaseable		UJ231	Brute Force Non Greaseable		UJ231
(For Aluminum Drive Shaft)		UJ331C	(For Aluminum Drive Shaft)		UJ331C
Clamp Kit (Fr. Shaft; Frt.)		UJ331-10	Clamp Kit (Fr. Shaft; Frt.)		UJ331-10
U-Joint (Rr. Shaft; Frt.) [⊙]		UJ351	U-Joint (Rr. Shaft; Frt.) [⊙]		UJ351
(For Aluminum Drive Shaft)		UJ351C	(For Aluminum Drive Shaft)		UJ351C
Brute Force Non Greaseable		UJ351BF	Brute Force Non Greaseable		UJ351BF
U-Joint (Rr. Shaft; Rr.) [⊙]		UJ351	U-Joint (Rr. Shaft; Rr.) [⊙]		UJ351
(For Aluminum Drive Shaft)		UJ351C	(For Aluminum Drive Shaft)		UJ351C
Brute Force Non Greaseable		UJ351BF	Brute Force Non Greaseable		UJ351BF
U-Joint (Wheel Joint) [⊙]	[2]	UJ374	U-Joint (Rr. Shaft; Rr.) [⊙]		UJ351
Brute Force Non Greaseable		UJ374BF	(For Aluminum Drive Shaft)		UJ351C
			Brute Force Non Greaseable		UJ351BF
2010-2009 F-350 Super Duty w/ Dual Rear Whls. & 3 Joint Driveshaft: [Type 29]			2008-2007 F-350 Super Duty w/ 2 Joint Shaft Exc. Cab & Chassis: [Type 28]		
U-Joint (Fr. Shaft; Frt.) [⊙]		UJ331	U-Joint (Fr. Shaft; Frt.) [⊙]		UJ331
Brute Force Greaseable		UJ232	Brute Force Greaseable		UJ232
Brute Force Non Greaseable		UJ231	Brute Force Non Greaseable		UJ231
(For Aluminum Drive Shaft)		UJ331C	(For Aluminum Drive Shaft)		UJ331C
Clamp Kit (Fr. Shaft; Frt.)		UJ331-10	Clamp Kit (Fr. Shaft; Frt.)		UJ331-10
U-Joint (Rr. Shaft; Frt.) [⊙]		UJ351	U-Joint (Rr. Shaft; Frt.) [⊙]		UJ330
(For Aluminum Drive Shaft)		UJ351C	Brute Force Greaseable		UJ295
Brute Force Non Greaseable		UJ351BF	(For Aluminum Drive Shaft)		UJ330C
U-Joint (Rr. Shaft; Ctr.) [⊙]		UJ351	Clamp Kit (Rr. Shaft; Frt.)		UJ331-10
(For Aluminum Drive Shaft)		UJ351C	U-Joint (Rr. Shaft; Rr.) [⊙]		UJ330
Brute Force Non Greaseable		UJ351BF	Brute Force Greaseable		UJ295
U-Joint (Rr. Shaft; Rr.) [⊙]		UJ351	(For Aluminum Drive Shaft)		UJ330C
(For Aluminum Drive Shaft)		UJ351C	Clamp Kit (Rr. Shaft; Rr.)		UJ331-10
Brute Force Non Greaseable		UJ351BF	U-Joint (Wheel Joint) [⊙]	[2]	UJ374
U-Joint (Wheel Joint) [⊙]	[2]	UJ374	Brute Force Non Greaseable		UJ374BF
Brute Force Non Greaseable		UJ374BF			(Continued)
2008-2007 F-350 Super Duty Cab & Chassis w/ 2 Joint Shaft: [Type 28]					
U-Joint (Fr. Shaft; Frt.) [⊙]		UJ331			
Brute Force Greaseable		UJ232			
Brute Force Non Greaseable		UJ231			
(For Aluminum Drive Shaft)		UJ331C			
Clamp Kit (Fr. Shaft; Frt.)		UJ331-10			
U-Joint (Rr. Shaft; Frt.) [⊙]		UJ351			
(For Aluminum Drive Shaft)		UJ351C			
Brute Force Non Greaseable		UJ351BF			
U-Joint (Rr. Shaft; Rr.) [⊙]		UJ351			
(For Aluminum Drive Shaft)		UJ351C			
Brute Force Non Greaseable		UJ351BF			
U-Joint (Wheel Joint) [⊙]	[2]	UJ374			
Brute Force Non Greaseable		UJ374BF			

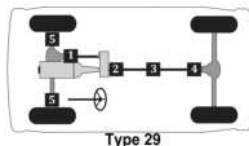
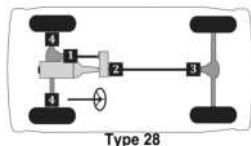

460 ▲ For Use w/ 1.063" Bearing Cap Application. ⊙ For Use w/ 1.188" Bearing Cap Application. ◇ For Use w/ Inner Lock Ring Application on Half Shaft. □ For Use w/ Outer Lock Ring Application on Half Shaft.

MFG./YEAR	MODEL & LOCATION	PART NO.	MFG./YEAR	MODEL & LOCATION	PART NO.
Drive Shaft (4 W/D) (Cont.)			Drive Shaft (4 W/D) (Cont.)		
U-Joint (Cont.)			U-Joint (Cont.)		
2008-2007 F-350 Super Duty w/ 3 Joint Shaft Exc.			2006-2005 F-350 Super Duty w/ 2 Joint Shaft:		
Cab & Chassis: [Type 29]			[Type 28]		
U-Joint (Fr. Shaft; Frt.)①		UJ331	U-Joint (Fr. Shaft; Frt.)①		UJ331
Brute Force Greaseable		UJ232	Brute Force Greaseable		UJ232
Brute Force Non Greaseable		UJ231	Brute Force Non Greaseable		UJ231
(For Aluminum Drive Shaft)		UJ331C	(For Aluminum Drive Shaft)		UJ331C
Clamp Kit (Fr. Shaft; Frt.)		UJ331-10	Clamp Kit (Fr. Shaft; Frt.)		UJ331-10
U-Joint (Rr. Shaft; Frt.)②		UJ330	U-Joint (Rr. Shaft; Frt.)②		UJ330
Brute Force Greaseable		UJ295	Brute Force Greaseable		UJ295
(For Aluminum Drive Shaft)		UJ330C	(For Aluminum Drive Shaft)		UJ330C
Clamp Kit (Rr. Shaft; Frt.)		UJ331-10	Clamp Kit (Rr. Shaft; Frt.)		UJ331-10
U-Joint (Rr. Shaft; Ctr.)③		UJ330	U-Joint (Rr. Shaft; Rr.)③		UJ330
Brute Force Greaseable		UJ295	Brute Force Greaseable		UJ295
(For Aluminum Drive Shaft)		UJ330C	(For Aluminum Drive Shaft)		UJ330C
Clamp Kit (Rr. Shaft; Ctr.)		UJ331-10	Clamp Kit (Rr. Shaft; Rr.)		UJ331-10
U-Joint (Rr. Shaft; Rr.)④		UJ330	U-Joint (Wheel Joint)⑤	[2]	UJ374
Brute Force Greaseable		UJ295	Brute Force Non Greaseable		UJ374BF
(For Aluminum Drive Shaft)		UJ330C	2006-2005 F-350 Super Duty w/ 3 Joint Shaft:		
Clamp Kit (Rr. Shaft; Rr.)		UJ331-10	[Type 29]		
U-Joint (Wheel Joint)⑤	[2]	UJ374	U-Joint (Fr. Shaft; Frt.)①		UJ331
Brute Force Non Greaseable		UJ374BF	Brute Force Greaseable		UJ232
2008-2007 F-350 Super Duty w/ CV Driveshaft			Brute Force Non Greaseable		UJ231
Exc. Cab & Chassis: [Type 28]			(For Aluminum Drive Shaft)		UJ331C
U-Joint (Fr. Shaft; Frt.)①		UJ331	Clamp Kit (Fr. Shaft; Frt.)		UJ331-10
Brute Force Greaseable		UJ232	U-Joint (Rr. Shaft; Frt.)②		UJ330
Brute Force Non Greaseable		UJ231	Brute Force Greaseable		UJ295
(For Aluminum Drive Shaft)		UJ331C	(For Aluminum Drive Shaft)		UJ330C
Clamp Kit (Fr. Shaft; Frt.)		UJ331-10	Clamp Kit (Rr. Shaft; Frt.)		UJ331-10
U-Joint (Rr. Shaft; Frt.)②	[2]	UJ331	U-Joint (Rr. Shaft; Ctr.)③		UJ330
Brute Force Greaseable		UJ232	Brute Force Greaseable		UJ295
Brute Force Non Greaseable		UJ231	(For Aluminum Drive Shaft)		UJ330C
(For Aluminum Drive Shaft)		UJ331C	Clamp Kit (Rr. Shaft; Ctr.)		UJ331-10
Clamp Kit (Rr. Shaft; Frt.)		UJ331-10	U-Joint (Rr. Shaft; Rr.)④		UJ330
U-Joint (Rr. Shaft; Rr.)③		UJ330	Brute Force Greaseable		UJ295
Brute Force Greaseable		UJ295	(For Aluminum Drive Shaft)		UJ330C
(For Aluminum Drive Shaft)		UJ330C	Clamp Kit (Rr. Shaft; Rr.)		UJ331-10
Clamp Kit (Rr. Shaft; Rr.)		UJ331-10	U-Joint (Wheel Joint)⑤	[2]	UJ374
U-Joint (Rr. Shaft; Rr.)④		UJ330	Brute Force Non Greaseable		UJ374BF
Brute Force Greaseable		UJ295			(Continued)
(For Aluminum Drive Shaft)		UJ330C			
Clamp Kit (Rr. Shaft; Rr.)		UJ331-10			
U-Joint (Wheel Joint)⑤	[2]	UJ374			
Brute Force Non Greaseable		UJ374BF			

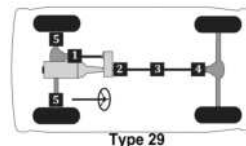
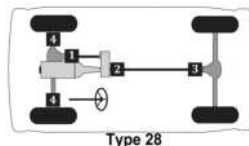

Passenger cars, light & medium trucks

Ford Truck 1 ton -- (Cont.)

MFG./YEAR	MODEL & LOCATION	PART NO.	MFG./YEAR	MODEL & LOCATION	PART NO.
Drive Shaft (4 W/D) (Cont.)			Drive Shaft (4 W/D) (Cont.)		
U-Joint (Cont.)			U-Joint (Cont.)		
2006-2005 F-350 Super Duty w/ CV Driveshaft:			2004-1999 F-350 Super Duty w/ 3 Joint Shaft & 5.4L Eng.: [Type 27]		
[Type 28]			[Type 27]		
U-Joint (Fr. Shaft; Fr.) ①		UJ331	U-Joint (Fr. Shaft; Fr.) ①		UJ331
<i>Brute Force Greaseable</i>		UJ232	<i>Brute Force Greaseable</i>		UJ232
<i>Brute Force Non Greaseable</i>		UJ231	<i>Brute Force Non Greaseable</i>		UJ231
(For Aluminum Drive Shaft)		UJ331C	(For Aluminum Drive Shaft)		UJ331C
Clamp Kit (Fr. Shaft; Fr.)		UJ331-10	Clamp Kit (Fr. Shaft; Fr.)		UJ331-10
U-Joint (Rr. Shaft; Fr.) ②	[2]	UJ331	U-Joint (Fr. Shaft; Rr.) ②	[2]	UJ331
<i>Brute Force Greaseable</i>		UJ232	<i>Brute Force Greaseable</i>		UJ232
<i>Brute Force Non Greaseable</i>		UJ231	<i>Brute Force Non Greaseable</i>		UJ231
(For Aluminum Drive Shaft)		UJ331C	(For Aluminum Drive Shaft)		UJ331C
Clamp Kit (Rr. Shaft; Fr.)		UJ331-10	Clamp Kit (Fr. Shaft; Rr.)		UJ331-10
U-Joint (Rr. Shaft; Rr.) ③		UJ330	U-Joint (Rr. Shaft; Fr.) ③		UJ331
<i>Brute Force Greaseable</i>		UJ295	<i>Brute Force Greaseable</i>		UJ232
(For Aluminum Drive Shaft)		UJ330C	<i>Brute Force Non Greaseable</i>		UJ231
Clamp Kit (Rr. Shaft; Rr.)		UJ331-10	(For Aluminum Drive Shaft)		UJ331C
U-Joint (Wheel Joint) ④	[2]	UJ374	Clamp Kit (Fr. Shaft; Rr.)		UJ331-10
<i>Brute Force Non Greaseable</i>		UJ374BF	U-Joint (Rr. Shaft; Rr.) ⑤		UJ331
2004-1999 F-350 Super Duty w/ 2 Joint Shaft & 5.4L Eng.: [Type 26]			<i>Brute Force Greaseable</i>		UJ232
U-Joint (Fr. Shaft; Fr.) ①		UJ331	<i>Brute Force Non Greaseable</i>		UJ231
<i>Brute Force Greaseable</i>		UJ232	(For Aluminum Drive Shaft)		UJ331C
<i>Brute Force Non Greaseable</i>		UJ231	Clamp Kit (Rr. Shaft; Rr.)		UJ331-10
(For Aluminum Drive Shaft)		UJ331C	U-Joint (Rr. Shaft; Ctr.) ⑥		UJ331
Clamp Kit (Fr. Shaft; Fr.)		UJ331-10	<i>Brute Force Greaseable</i>		UJ232
U-Joint (Fr. Shaft; Rr.) ②	[2]	UJ331	<i>Brute Force Non Greaseable</i>		UJ231
<i>Brute Force Greaseable</i>		UJ232	(For Aluminum Drive Shaft)		UJ331C
<i>Brute Force Non Greaseable</i>		UJ231	Clamp Kit (Rr. Shaft; Ctr.)		UJ331-10
(For Aluminum Drive Shaft)		UJ331C	U-Joint (Wheel Joint) ⑥	[2]	UJ374
Clamp Kit (Fr. Shaft; Rr.)		UJ331-10	<i>Brute Force Non Greaseable</i>		UJ374BF
U-Joint (Rr. Shaft; Fr.) ③		UJ331	Ball Seat Repair Kit		UJ617
<i>Brute Force Greaseable</i>		UJ232	Flange Yoke		UJ630F
<i>Brute Force Non Greaseable</i>		UJ231	H Yoke		UJ650
(For Aluminum Drive Shaft)		UJ331C			(Continued)
Clamp Kit (Rr. Shaft; Fr.)		UJ331-10			
U-Joint (Rr. Shaft; Rr.) ④		UJ331			
<i>Brute Force Greaseable</i>		UJ232			
<i>Brute Force Non Greaseable</i>		UJ231			
(For Aluminum Drive Shaft)		UJ331C			
Clamp Kit (Rr. Shaft; Rr.)		UJ331-10			
U-Joint (Wheel Joint) ⑤	[2]	UJ374			
<i>Brute Force Non Greaseable</i>		UJ374BF			
Ball Seat Repair Kit		UJ617			
Flange Yoke		UJ630F			
H Yoke		UJ650			

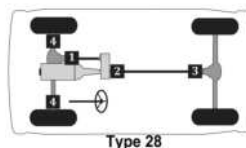
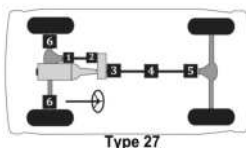
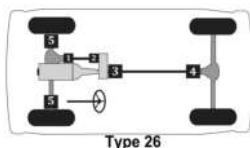

MFG./YEAR	MODEL & LOCATION	PART NO.	MFG./YEAR	MODEL & LOCATION	PART NO.
Drive Shaft (4 W/D) (Cont.)			Drive Shaft (4 W/D) (Cont.)		
U-Joint (Cont.)			U-Joint (Cont.)		
2004-1999 F-350 Super Duty w/ CV Driveshaft & 5.4L Eng.: [Type 26]			2004-1999 F-350 Super Duty w/ 2 Joint Shaft, 6.0L, 6.8L & 7.3L Eng.: [Type 26]		
	U-Joint (Frnt. Shaft; Frnt.) ①	UJ331		U-Joint (Frnt. Shaft; Frnt.) ①	UJ331
	<i>Brute Force Greaseable</i>	UJ232		<i>Brute Force Greaseable</i>	UJ232
	<i>Brute Force Non Greaseable</i>	UJ231		<i>Brute Force Non Greaseable</i>	UJ231
	(For Aluminum Drive Shaft)	UJ331C		(For Aluminum Drive Shaft)	UJ331C
	Clamp Kit (Frnt. Shaft; Frnt.)	UJ331-10		Clamp Kit (Frnt. Shaft; Frnt.)	UJ331-10
	U-Joint (Frnt. Shaft; Rr.) ②	[2] UJ331		U-Joint (Frnt. Shaft; Rr.) ②	[2] UJ331
	<i>Brute Force Greaseable</i>	UJ232		<i>Brute Force Greaseable</i>	UJ232
	<i>Brute Force Non Greaseable</i>	UJ231		<i>Brute Force Non Greaseable</i>	UJ231
	(For Aluminum Drive Shaft)	UJ331C		(For Aluminum Drive Shaft)	UJ331C
	Clamp Kit (Frnt. Shaft; Rr.)	UJ331-10		Clamp Kit (Frnt. Shaft; Rr.)	UJ331-10
	U-Joint (Rr. Shaft; Frnt.) ③	[2] UJ331		U-Joint (Rr. Shaft; Frnt.) ③	UJ330
	<i>Brute Force Greaseable</i>	UJ232		<i>Brute Force Greaseable</i>	UJ295
	<i>Brute Force Non Greaseable</i>	UJ231		(For Aluminum Drive Shaft)	UJ330C
	(For Aluminum Drive Shaft)	UJ331C		Clamp Kit (Rr. Shaft; Frnt.)	UJ331-10
	Clamp Kit (Rr. Shaft; Frnt.)	UJ331-10		U-Joint (Rr. Shaft; Rr.) ④	UJ330
	U-Joint (Rr. Shaft; Rr.) ④	UJ331		<i>Brute Force Greaseable</i>	UJ295
	<i>Brute Force Greaseable</i>	UJ232		(For Aluminum Drive Shaft)	UJ330C
	<i>Brute Force Non Greaseable</i>	UJ231		Clamp Kit (Rr. Shaft; Rr.)	UJ331-10
	(For Aluminum Drive Shaft)	UJ331C		U-Joint (Wheel Joint) ⑤	[2] UJ374
	Clamp Kit (Rr. Shaft; Rr.)	UJ331-10		<i>Brute Force Non Greaseable</i>	UJ374BF
	U-Joint (Wheel Joint) ⑤	[2] UJ374		Ball Seat Repair Kit	UJ617
	<i>Brute Force Non Greaseable</i>	UJ374BF		Flange Yoke	UJ630F
	Ball Seat Repair Kit	UJ617		H Yoke	UJ650
	Flange Yoke	UJ630F			(Continued)
	H Yoke	UJ650			

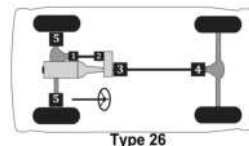

Passenger cars, light & medium trucks

Ford Truck 1 ton -- (Cont.)

MFG./YEAR	MODEL & LOCATION	PART NO.	MFG./YEAR	MODEL & LOCATION	PART NO.
Drive Shaft (4 W/D) (Cont.)			Drive Shaft (4 W/D) (Cont.)		
U-Joint (Cont.)			U-Joint (Cont.)		
2004-1999 F-350 Super Duty w/ 3 Joint Shaft, 6.0L, 6.8L & 7.3L Engs.: [Type 27]			2004-1999 F-350 Super Duty w/ CV Driveshaft, 6.0L, 6.8L & 7.3L Engs.: [Type 26]		
U-Joint (Fr. Shaft; Frt.) [⊙]		UJ331	U-Joint (Fr. Shaft; Frt.) [⊙]		UJ331
Brute Force Greaseable		UJ232	Brute Force Greaseable		UJ232
Brute Force Non Greaseable		UJ231	Brute Force Non Greaseable		UJ231
(For Aluminum Drive Shaft)		UJ331C	(For Aluminum Drive Shaft)		UJ331C
Clamp Kit (Fr. Shaft; Frt.)		UJ331-10	Clamp Kit (Fr. Shaft; Frt.)		UJ331-10
U-Joint (Fr. Shaft; Rr.) [⊙]	[2]	UJ331	U-Joint (Fr. Shaft; Rr.) [⊙]	[2]	UJ331
Brute Force Greaseable		UJ232	Brute Force Greaseable		UJ232
Brute Force Non Greaseable		UJ231	Brute Force Non Greaseable		UJ231
(For Aluminum Drive Shaft)		UJ331C	(For Aluminum Drive Shaft)		UJ331C
Clamp Kit (Fr. Shaft; Rr.)		UJ331-10	Clamp Kit (Fr. Shaft; Rr.)		UJ331-10
U-Joint (Rr. Shaft; Frt.) [⊙]		UJ330	U-Joint (Rr. Shaft; Frt.) [⊙]	[2]	UJ331
Brute Force Greaseable		UJ295	Brute Force Greaseable		UJ232
(For Aluminum Drive Shaft)		UJ330C	Brute Force Non Greaseable		UJ231
Clamp Kit (Rr. Shaft; Frt.)		UJ331-10	(For Aluminum Drive Shaft)		UJ331C
U-Joint (Rr. Shaft; Ctr.) [⊙]		UJ330	Clamp Kit (Rr. Shaft; Frt.)		UJ331-10
Brute Force Greaseable		UJ295	U-Joint (Rr. Shaft; Rr.) [⊙]		UJ330
(For Aluminum Drive Shaft)		UJ330C	Brute Force Greaseable		UJ295
Clamp Kit (Rr. Shaft; Ctr.)		UJ331-10	(For Aluminum Drive Shaft)		UJ330C
U-Joint (Rr. Shaft; Rr.) [⊙]		UJ330	Clamp Kit (Rr. Shaft; Rr.)		UJ331-10
Brute Force Greaseable		UJ295	U-Joint (Wheel Joint) [⊙]	[2]	UJ374
(For Aluminum Drive Shaft)		UJ330C	Brute Force Non Greaseable		UJ374BF
Clamp Kit (Rr. Shaft; Rr.)		UJ331-10	Ball Seat Repair Kit		UJ617
U-Joint (Wheel Joint) [⊙]	[2]	UJ374	Flange Yoke		UJ630F
Brute Force Non Greaseable		UJ374BF	H Yoke		UJ650
Ball Seat Repair Kit		UJ617	1997-1994 F-350 w/ 133" Wheel Base & 5.8L Eng.		
Flange Yoke		UJ630F	[Type 26]		
H Yoke		UJ650	U-Joint (Fr. Shaft; Frt.) [⊙]		UJ434
			Brute Force Greaseable		UJ265
			Brute Force Non Greaseable		UJ264
			U-Bolt Kit (Fr. Shaft; Frt.)		UJ534-10
			U-Joint (Fr. Shaft; Rr.) [⊙]	[2]	UJ354
			Brute Force Greaseable		UJ270
			Brute Force Non Greaseable		UJ254
			(For Aluminum Drive Shaft)		UJ354C
			U-Joint (Rr. Shaft; Frt.) [⊙]		UJ354
			Brute Force Greaseable		UJ270
			Brute Force Non Greaseable		UJ254
			(For Aluminum Drive Shaft)		UJ354C
			U-Joint (Rr. Shaft; Rr.) [⊙]		UJ434
			Brute Force Greaseable		UJ265
			Brute Force Non Greaseable		UJ264
			U-Bolt Kit (Rr. Shaft; Rr.)		UJ534-10
			U-Joint (Wheel Joint) [⊙]	[2]	UJ374
			Brute Force Non Greaseable		UJ374BF
			Centering Yoke		UJ608
			Weld Yoke		UJ638
			H Yoke		UJ648

(Continued)

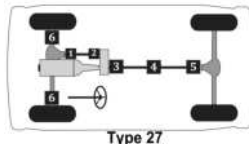
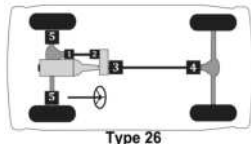

MFG./YEAR	MODEL & LOCATION	PART NO.	MFG./YEAR	MODEL & LOCATION	PART NO.
Drive Shaft (4 W/D) (Cont.)			Drive Shaft (4 W/D) (Cont.)		
U-Joint (Cont.)			U-Joint (Cont.)		
1997-1994 F-350 w/ 133" Wheel Base, 7.3L & 7.5L			1997-1990 F-350 w/ 160" & 168" Wheel Base:		
Engs.: [Type 26]			[Type 27]		
U-Joint (Fr. Shaft; Frt.)		UJ434	U-Joint (Fr. Shaft; Frt.)		UJ434
Brute Force Greaseable		UJ265	Brute Force Greaseable		UJ265
Brute Force Non Greaseable		UJ264	Brute Force Non Greaseable		UJ264
U-Bolt Kit (Fr. Shaft; Frt.)		UJ534-10	U-Bolt Kit (Fr. Shaft; Frt.)		UJ534-10
U-Joint (Fr. Shaft; Rr.)	[2]	UJ354	U-Joint (Fr. Shaft; Rr.)	[2]	UJ354
Brute Force Greaseable		UJ270	Brute Force Greaseable		UJ270
Brute Force Non Greaseable		UJ254	Brute Force Non Greaseable		UJ254
(For Aluminum Drive Shaft)		UJ354C	(For Aluminum Drive Shaft)		UJ354C
U-Joint (Rr. Shaft; Frt.)		UJ331	U-Joint (Rr. Shaft; Frt.)		UJ331
Brute Force Greaseable		UJ232	Brute Force Greaseable		UJ232
Brute Force Non Greaseable		UJ231	Brute Force Non Greaseable		UJ231
(For Aluminum Drive Shaft)		UJ331C	(For Aluminum Drive Shaft)		UJ331C
Clamp Kit (Rr. Shaft; Frt.)		UJ331-10	Clamp Kit (Rr. Shaft; Frt.)		UJ331-10
U-Joint (Rr. Shaft; Rr.)		UJ331	U-Joint (Rr. Shaft; Rr.)		UJ331
Brute Force Greaseable		UJ232	Brute Force Greaseable		UJ232
Brute Force Non Greaseable		UJ231	Brute Force Non Greaseable		UJ231
(For Aluminum Drive Shaft)		UJ331C	(For Aluminum Drive Shaft)		UJ331C
Clamp Kit (Rr. Shaft; Rr.)		UJ331-10	Clamp Kit (Rr. Shaft; Ctr.)		UJ331-10
U-Joint (Wheel Joint)	[2]	UJ374	U-Joint (Rr. Shaft; Rr.)		UJ331
Brute Force Non Greaseable		UJ374BF	Brute Force Greaseable		UJ232
Centering Yoke		UJ608	Brute Force Non Greaseable		UJ231
Weld Yoke		UJ638	(For Aluminum Drive Shaft)		UJ331C
H Yoke		UJ648	Clamp Kit (Rr. Shaft; Rr.)		UJ331-10
1997-1990 F-350 w/ 136" Wheel Base: [Type 26]			U-Joint (Wheel Joint)	[2]	UJ374
U-Joint (Fr. Shaft; Frt.)		UJ434	Brute Force Non Greaseable		UJ374BF
Brute Force Greaseable		UJ265	Centering Yoke		UJ608
Brute Force Non Greaseable		UJ264	Weld Yoke		UJ638
U-Bolt Kit (Fr. Shaft; Frt.)		UJ534-10			(Continued)
U-Joint (Fr. Shaft; Rr.)	[2]	UJ354			
Brute Force Greaseable		UJ270			
Brute Force Non Greaseable		UJ254			
(For Aluminum Drive Shaft)		UJ354C			
U-Joint (Rr. Shaft; Frt.)		UJ331			
Brute Force Greaseable		UJ232			
Brute Force Non Greaseable		UJ231			
(For Aluminum Drive Shaft)		UJ331C			
Clamp Kit (Rr. Shaft; Frt.)		UJ331-10			
U-Joint (Rr. Shaft; Rr.)		UJ331			
Brute Force Greaseable		UJ232			
Brute Force Non Greaseable		UJ231			
(For Aluminum Drive Shaft)		UJ331C			
Clamp Kit (Rr. Shaft; Rr.)		UJ331-10			
U-Joint (Wheel Joint)	[2]	UJ374			
Brute Force Non Greaseable		UJ374BF			
Centering Yoke		UJ608			
Weld Yoke		UJ638			

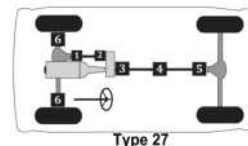
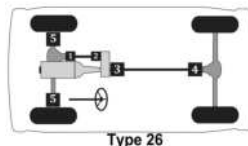

Passenger cars, light & medium trucks

Ford Truck 1 ton -- (Cont.)

MFG./YEAR	MODEL & LOCATION	PART NO.	MFG./YEAR	MODEL & LOCATION	PART NO.
Drive Shaft (4 W/D) (Cont.)			Drive Shaft (4 W/D) (Cont.)		
U-Joint (Cont.)			U-Joint (Cont.)		
1993-1990 F-350 w/ 133" Wheel Base & Auto.			1993-1990 F-350 w/ 133" Wheel Base, Man.		
Trans.: [Type 26]			Trans., 7.3L & 7.5L Eng.: [Type 26]		
U-Joint (Fr. Shaft; Frt.)⊙		UJ434	U-Joint (Fr. Shaft; Frt.)⊙		UJ434
Brute Force Greaseable		UJ265	Brute Force Greaseable		UJ265
Brute Force Non Greaseable		UJ264	Brute Force Non Greaseable		UJ264
U-Bolt Kit (Fr. Shaft; Frt.)		UJ534-10	U-Bolt Kit (Fr. Shaft; Frt.)		UJ534-10
U-Joint (Fr. Shaft; Rr.)⊙	[2]	UJ354	U-Joint (Fr. Shaft; Rr.)⊙	[2]	UJ354
Brute Force Greaseable		UJ270	Brute Force Greaseable		UJ270
Brute Force Non Greaseable		UJ254	Brute Force Non Greaseable		UJ254
(For Aluminum Drive Shaft)		UJ354C	(For Aluminum Drive Shaft)		UJ354C
U-Joint (Rr. Shaft; Frt.)⊙		UJ354	U-Joint (Rr. Shaft; Frt.)⊙		UJ331
Brute Force Greaseable		UJ270	Brute Force Greaseable		UJ232
Brute Force Non Greaseable		UJ254	Brute Force Non Greaseable		UJ231
(For Aluminum Drive Shaft)		UJ354C	(For Aluminum Drive Shaft)		UJ331C
U-Joint (Rr. Shaft; Rr.)⊙		UJ434	Clamp Kit (Rr. Shaft; Frt.)		UJ331-10
Brute Force Greaseable		UJ265	U-Joint (Rr. Shaft; Rr.)⊙		UJ331
Brute Force Non Greaseable		UJ264	Brute Force Greaseable		UJ232
U-Bolt Kit (Rr. Shaft; Rr.)		UJ534-10	Brute Force Non Greaseable		UJ231
U-Joint (Wheel Joint)⊙	[2]	UJ374	(For Aluminum Drive Shaft)		UJ331C
Brute Force Non Greaseable		UJ374BF	Clamp Kit (Rr. Shaft; Rr.)		UJ331-10
Centering Yoke		UJ608	U-Joint (Wheel Joint)⊙	[2]	UJ374
Weld Yoke		UJ638	Brute Force Non Greaseable		UJ374BF
H Yoke		UJ648	Centering Yoke		UJ608
			Weld Yoke		UJ638
			H Yoke		UJ648
1993-1990 F-350 w/ 133" Wheel Base, Man.			1989-1988 F-350 w/ Frt. Shaft Outer Lock Ring,		
Trans. & 5.8L Eng.: [Type 26]			133" WB & Auto. Trans.: [Type 26]		
U-Joint (Fr. Shaft; Frt.)⊙		UJ434	U-Joint (Fr. Shaft; Frt.)⊙		UJ434
Brute Force Greaseable		UJ265	Brute Force Greaseable		UJ265
Brute Force Non Greaseable		UJ264	Brute Force Non Greaseable		UJ264
U-Bolt Kit (Fr. Shaft; Frt.)		UJ534-10	U-Bolt Kit (Fr. Shaft; Frt.)		UJ534-10
U-Joint (Fr. Shaft; Rr.)⊙	[2]	UJ354	U-Joint (Fr. Shaft; Rr.)⊙	[2]	UJ354
Brute Force Greaseable		UJ270	Brute Force Greaseable		UJ270
Brute Force Non Greaseable		UJ254	Brute Force Non Greaseable		UJ254
(For Aluminum Drive Shaft)		UJ354C	(For Aluminum Drive Shaft)		UJ354C
U-Joint (Rr. Shaft; Frt.)⊙		UJ354	U-Joint (Rr. Shaft; Frt.)⊙		UJ354
Brute Force Greaseable		UJ270	Brute Force Greaseable		UJ270
Brute Force Non Greaseable		UJ254	Brute Force Non Greaseable		UJ254
(For Aluminum Drive Shaft)		UJ354C	(For Aluminum Drive Shaft)		UJ354C
U-Joint (Rr. Shaft; Rr.)⊙		UJ434	U-Joint (Rr. Shaft; Rr.)⊙		UJ434
Brute Force Greaseable		UJ265	Brute Force Greaseable		UJ265
Brute Force Non Greaseable		UJ264	Brute Force Non Greaseable		UJ264
U-Bolt Kit (Rr. Shaft; Rr.)		UJ534-10	U-Bolt Kit (Rr. Shaft; Rr.)		UJ534-10
U-Joint (Wheel Joint)⊙	[2]	UJ374	U-Joint (Wheel Joint)⊙	[2]	UJ374
Brute Force Non Greaseable		UJ374BF	Brute Force Non Greaseable		UJ374BF
Centering Yoke		UJ608	Centering Yoke		UJ608
Weld Yoke		UJ638	Weld Yoke		UJ638
H Yoke		UJ648	H Yoke		UJ648

(Continued)

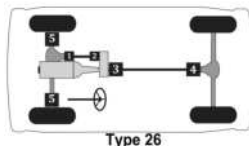

MFG./YEAR	MODEL & LOCATION	PART NO.	MFG./YEAR	MODEL & LOCATION	PART NO.
Drive Shaft (4 W/D) (Cont.)			Drive Shaft (4 W/D) (Cont.)		
U-Joint (Cont.)			U-Joint (Cont.)		
1989-1988 F-350 w/ Frt. Shaft Outer Lock Ring, 133" WB & Man. Trans. & 5.8L Eng.:			1989-1988 F-350 w/ Frt. Shaft Outer Lock Ring, 136" WB & HD 5 Spd. Man. Trans.:		
[Type 26]			[Type 26]		
U-Joint (Frt. Shaft; Frt.)Ⓛ		UJ434	U-Joint (Frt. Shaft; Frt.)Ⓛ		UJ434
Brute Force Greaseable		UJ265	Brute Force Greaseable		UJ265
Brute Force Non Greaseable		UJ264	Brute Force Non Greaseable		UJ264
U-Bolt Kit (Frt. Shaft; Frt.)		UJ534-10	U-Bolt Kit (Frt. Shaft; Frt.)		UJ534-10
U-Joint (Frt. Shaft; Rr.)Ⓛ	[2]	UJ354	U-Joint (Frt. Shaft; Rr.)Ⓛ	[2]	UJ354
Brute Force Greaseable		UJ270	Brute Force Greaseable		UJ270
Brute Force Non Greaseable		UJ254	Brute Force Non Greaseable		UJ254
(For Aluminum Drive Shaft)		UJ354C	(For Aluminum Drive Shaft)		UJ354C
U-Joint (Rr. Shaft; Frt.)Ⓛ		UJ354	U-Joint (Rr. Shaft; Frt.)Ⓛ		UJ354
Brute Force Greaseable		UJ270	Brute Force Greaseable		UJ270
Brute Force Non Greaseable		UJ254	Brute Force Non Greaseable		UJ254
(For Aluminum Drive Shaft)		UJ354C	(For Aluminum Drive Shaft)		UJ354C
U-Joint (Rr. Shaft; Rr.)Ⓛ		UJ434	U-Joint (Rr. Shaft; Rr.)Ⓛ		UJ434
Brute Force Greaseable		UJ265	Brute Force Greaseable		UJ265
Brute Force Non Greaseable		UJ264	Brute Force Non Greaseable		UJ264
U-Bolt Kit (Rr. Shaft; Rr.)		UJ534-10	U-Bolt Kit (Rr. Shaft; Rr.)		UJ534-10
U-Joint (Wheel Joint)Ⓛ	[2]	UJ374	U-Joint (Wheel Joint)Ⓛ	[2]	UJ374
Brute Force Non Greaseable		UJ374BF	Brute Force Non Greaseable		UJ374BF
Centering Yoke		UJ608	Centering Yoke		UJ608
Weld Yoke		UJ638	Weld Yoke		UJ638
H Yoke		UJ648	H Yoke		UJ648
1989-1988 F-350 w/ Frt. Shaft Outer Lock Ring, 133" WB & Man. Trans., 7.3L & 7.5L Eng.: [Type 26]			1989-1988 F-350 w/ Frt. Shaft Outer Lock Ring & 136" WB Exc. HD 5 Spd. Man. Trans.:		
[Type 26]			[Type 26]		
U-Joint (Frt. Shaft; Frt.)Ⓛ		UJ434	U-Joint (Frt. Shaft; Frt.)Ⓛ		UJ434
Brute Force Greaseable		UJ265	Brute Force Greaseable		UJ265
Brute Force Non Greaseable		UJ264	Brute Force Non Greaseable		UJ264
U-Bolt Kit (Frt. Shaft; Frt.)		UJ534-10	U-Bolt Kit (Frt. Shaft; Frt.)		UJ534-10
U-Joint (Frt. Shaft; Rr.)Ⓛ	[2]	UJ354	U-Joint (Frt. Shaft; Rr.)Ⓛ	[2]	UJ354
Brute Force Greaseable		UJ270	Brute Force Greaseable		UJ270
Brute Force Non Greaseable		UJ254	Brute Force Non Greaseable		UJ254
(For Aluminum Drive Shaft)		UJ354C	(For Aluminum Drive Shaft)		UJ354C
U-Joint (Rr. Shaft; Frt.)Ⓛ		UJ331	U-Joint (Rr. Shaft; Frt.)Ⓛ		UJ331
Brute Force Greaseable		UJ232	Brute Force Greaseable		UJ232
Brute Force Non Greaseable		UJ231	Brute Force Non Greaseable		UJ231
(For Aluminum Drive Shaft)		UJ331C	(For Aluminum Drive Shaft)		UJ331C
Clamp Kit (Rr. Shaft; Frt.)		UJ331-10	Clamp Kit (Rr. Shaft; Frt.)		UJ331-10
U-Joint (Rr. Shaft; Rr.)Ⓛ		UJ331	U-Joint (Rr. Shaft; Rr.)Ⓛ		UJ331
Brute Force Greaseable		UJ232	Brute Force Greaseable		UJ232
Brute Force Non Greaseable		UJ231	Brute Force Non Greaseable		UJ231
(For Aluminum Drive Shaft)		UJ331C	(For Aluminum Drive Shaft)		UJ331C
Clamp Kit (Rr. Shaft; Rr.)		UJ331-10	Clamp Kit (Rr. Shaft; Rr.)		UJ331-10
U-Joint (Wheel Joint)Ⓛ	[2]	UJ374	U-Joint (Wheel Joint)Ⓛ	[2]	UJ374
Brute Force Non Greaseable		UJ374BF	Brute Force Non Greaseable		UJ374BF
Centering Yoke		UJ608	Centering Yoke		UJ608
Weld Yoke		UJ638	Weld Yoke		UJ638
H Yoke		UJ648	H Yoke		UJ648

(Continued)

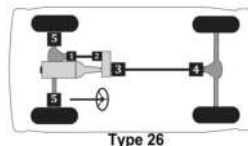

Passenger cars, light & medium trucks

Ford Truck 1 ton -- (Cont.)

MFG./YEAR	MODEL & LOCATION	PART NO.	MFG./YEAR	MODEL & LOCATION	PART NO.
Drive Shaft (4 W/D) (Cont.)			Drive Shaft (4 W/D) (Cont.)		
U-Joint (Cont.)			U-Joint (Cont.)		
1989-1988 F-350 w/ Frt. Shaft Outer Lock Ring & 160" Wheel Base: [Type 27]			1989-1988 F-350 w/ Frt. Shaft Outer Lock Ring, 2 Joint Shaft & 168" Wheel Base: [Type 26]		
	U-Joint (Frt. Shaft; Frt.) Ⓚ	UJ434		U-Joint (Frt. Shaft; Frt.) Ⓚ	UJ434
	<i>Brute Force Greaseable</i>	UJ265		<i>Brute Force Greaseable</i>	UJ265
	<i>Brute Force Non Greaseable</i>	UJ264		<i>Brute Force Non Greaseable</i>	UJ264
	U-Bolt Kit (Frt. Shaft; Frt.)	UJ534-10		U-Bolt Kit (Frt. Shaft; Frt.)	UJ534-10
	U-Joint (Frt. Shaft; Rr.) Ⓚ	[2] UJ354		U-Joint (Frt. Shaft; Rr.) Ⓚ	[2] UJ354
	<i>Brute Force Greaseable</i>	UJ270		<i>Brute Force Greaseable</i>	UJ270
	<i>Brute Force Non Greaseable</i>	UJ254		<i>Brute Force Non Greaseable</i>	UJ254
	(For Aluminum Drive Shaft)	UJ354C		(For Aluminum Drive Shaft)	UJ354C
	U-Joint (Rr. Shaft; Frt.) Ⓚ	UJ331		U-Joint (Rr. Shaft; Frt.) Ⓚ	UJ331
	<i>Brute Force Greaseable</i>	UJ232		<i>Brute Force Greaseable</i>	UJ232
	<i>Brute Force Non Greaseable</i>	UJ231		<i>Brute Force Non Greaseable</i>	UJ231
	(For Aluminum Drive Shaft)	UJ331C		(For Aluminum Drive Shaft)	UJ331C
	Clamp Kit (Rr. Shaft; Frt.)	UJ331-10		Clamp Kit (Rr. Shaft; Frt.)	UJ331-10
	U-Joint (Rr. Shaft; Ctr.) Ⓚ	UJ331		U-Joint (Rr. Shaft; Rr.) Ⓚ	UJ331
	<i>Brute Force Greaseable</i>	UJ232		<i>Brute Force Greaseable</i>	UJ232
	<i>Brute Force Non Greaseable</i>	UJ231		<i>Brute Force Non Greaseable</i>	UJ231
	(For Aluminum Drive Shaft)	UJ331C		(For Aluminum Drive Shaft)	UJ331C
	Clamp Kit (Rr. Shaft; Ctr.)	UJ331-10		Clamp Kit (Rr. Shaft; Rr.)	UJ331-10
	U-Joint (Rr. Shaft; Rr.) Ⓚ	UJ331		U-Joint (Wheel Joint) Ⓚ	[2] UJ374
	<i>Brute Force Greaseable</i>	UJ232		<i>Brute Force Non Greaseable</i>	UJ374BF
	<i>Brute Force Non Greaseable</i>	UJ231		Centering Yoke	UJ608
	(For Aluminum Drive Shaft)	UJ331C		Weld Yoke	UJ638
	Clamp Kit (Rr. Shaft; Rr.)	UJ331-10		H Yoke	UJ648
	U-Joint (Wheel Joint) Ⓚ	[2] UJ374			
	<i>Brute Force Non Greaseable</i>	UJ374BF			
	Centering Yoke	UJ608			
	Weld Yoke	UJ638			
	H Yoke	UJ648			

(Continued)

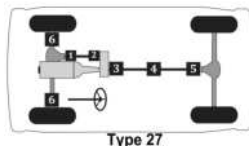
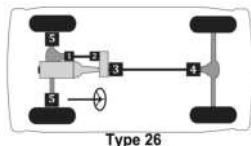

MFG./YEAR	MODEL & LOCATION	PART NO.	MFG./YEAR	MODEL & LOCATION	PART NO.
Drive Shaft (4 W/D) (Cont.)			Drive Shaft (4 W/D) (Cont.)		
U-Joint (Cont.)			U-Joint (Cont.)		
1989-1988 F-350 w/ Frt. Shaft Outer Lock Ring, 3 Joint Shaft & 168" Wheel Base: [Typ 27]			1989-1988 F-350 w/ Frt. Shaft Inner Lock Ring, 133" WB & Auto. Trans.: [Type 31]		
U-Joint (Frt. Shaft; Frt.) ^①		UJ434	U-Joint (Frt. Shaft; Frt.) ^①		UJ434
Brute Force Greaseable		UJ265	Brute Force Greaseable		UJ265
Brute Force Non Greaseable		UJ264	Brute Force Non Greaseable		UJ264
U-Bolt Kit (Frt. Shaft; Frt.)		UJ534-10	U-Bolt Kit (Frt. Shaft; Frt.)		UJ534-10
U-Joint (Frt. Shaft; Rr.) ^②	[2]	UJ354	U-Joint (Frt. Shaft; Ctr.) ^②		UJ534G
Brute Force Greaseable		UJ270	Brute Force Greaseable		UJ235
Brute Force Non Greaseable		UJ254	Brute Force Non Greaseable		UJ234
(For Aluminum Drive Shaft)		UJ354C	U-Joint (Frt. Shaft; Rr.) ^③		UJ355
U-Joint (Rr. Shaft; Frt.) ^③		UJ331	Brute Force Greaseable		UJ290
Brute Force Greaseable		UJ232	(For Aluminum Drive Shaft)		UJ355C
Brute Force Non Greaseable		UJ231	U-Joint (Rr. Shaft; Frt.) ^④		UJ354
(For Aluminum Drive Shaft)		UJ331C	Brute Force Greaseable		UJ270
Clamp Kit (Rr. Shaft; Frt.)		UJ331-10	Brute Force Non Greaseable		UJ254
U-Joint (Rr. Shaft; Ctr.) ^④		UJ331	(For Aluminum Drive Shaft)		UJ354C
Brute Force Greaseable		UJ232	U-Joint (Rr. Shaft; Rr.) ^⑤		UJ434
Brute Force Non Greaseable		UJ231	Brute Force Greaseable		UJ265
(For Aluminum Drive Shaft)		UJ331C	Brute Force Non Greaseable		UJ264
Clamp Kit (Rr. Shaft; Ctr.)		UJ331-10	U-Bolt Kit (Rr. Shaft; Rr.)		UJ534-10
U-Joint (Rr. Shaft; Rr.) ^⑤		UJ331	U-Joint (Wheel Joint) ^⑥	[2]	UJ374
Brute Force Greaseable		UJ232	Brute Force Non Greaseable		UJ374BF
Brute Force Non Greaseable		UJ231	1989-1988 F-350 w/ Frt. Shaft Inner Lock Ring, 133" WB & Man. Trans. & 5.8L Eng.: [Type 31]		
(For Aluminum Drive Shaft)		UJ331C	U-Joint (Frt. Shaft; Frt.) ^①		UJ434
Clamp Kit (Rr. Shaft; Rr.)		UJ331-10	Brute Force Greaseable		UJ265
U-Joint (Wheel Joint) ^⑥	[2]	UJ374	Brute Force Non Greaseable		UJ264
Brute Force Non Greaseable		UJ374BF	U-Bolt Kit (Frt. Shaft; Frt.)		UJ534-10
Centering Yoke		UJ608	U-Joint (Frt. Shaft; Ctr.) ^②		UJ534G
Weld Yoke		UJ638	Brute Force Greaseable		UJ235
H Yoke		UJ648	Brute Force Non Greaseable		UJ234
			U-Joint (Frt. Shaft; Rr.) ^③		UJ355
			Brute Force Greaseable		UJ290
			(For Aluminum Drive Shaft)		UJ355C
			U-Joint (Rr. Shaft; Frt.) ^④		UJ354
			Brute Force Greaseable		UJ270
			Brute Force Non Greaseable		UJ254
			(For Aluminum Drive Shaft)		UJ354C
			U-Joint (Rr. Shaft; Rr.) ^⑤		UJ434
			Brute Force Greaseable		UJ265
			Brute Force Non Greaseable		UJ264
			U-Bolt Kit (Rr. Shaft; Rr.)		UJ534-10
			U-Joint (Wheel Joint) ^⑥	[2]	UJ374
			Brute Force Non Greaseable		UJ374BF

(Continued)

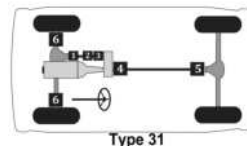
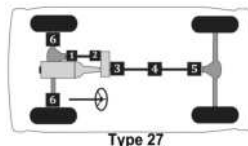

Passenger cars, light & medium trucks

Ford Truck 1 ton -- (Cont.)

MFG./YEAR	MODEL & LOCATION	PART NO.	MFG./YEAR	MODEL & LOCATION	PART NO.
Drive Shaft (4 W/D) (Cont.)			Drive Shaft (4 W/D) (Cont.)		
U-Joint (Cont.)			U-Joint (Cont.)		
1989-1988 F-350 w/ Frt. Shaft Inner Lock Ring, 133" WB & Man. Trans., 7.3L & 7.5L Engs.: [Type 31]			1989-1988 F-350 w/ Frt. Shaft Inner Lock Ring & 136" WB Exc. HD 5 Spd. Man. Trans.: [Type 31]		
U-Joint (Frt. Shaft; Frt.)ⓐ		UJ434	U-Joint (Frt. Shaft; Frt.)ⓐ		UJ434
Brute Force Greaseable		UJ265	Brute Force Greaseable		UJ265
Brute Force Non Greaseable		UJ264	Brute Force Non Greaseable		UJ264
U-Bolt Kit (Frt. Shaft; Frt.)		UJ534-10	U-Bolt Kit (Frt. Shaft; Frt.)		UJ534-10
U-Joint (Frt. Shaft; Ctr.)ⓑ		UJ534G	U-Joint (Frt. Shaft; Ctr.)ⓑ		UJ534G
Brute Force Greaseable		UJ235	Brute Force Greaseable		UJ235
Brute Force Non Greaseable		UJ234	Brute Force Non Greaseable		UJ234
U-Joint (Frt. Shaft; Rr.)ⓐ		UJ355	U-Joint (Frt. Shaft; Rr.)ⓐ		UJ355
Brute Force Greaseable		UJ290	Brute Force Greaseable		UJ290
(For Aluminum Drive Shaft)		UJ355C	(For Aluminum Drive Shaft)		UJ355C
U-Joint (Rr. Shaft; Frt.)ⓐ		UJ331	U-Joint (Rr. Shaft; Frt.)ⓐ		UJ331
Brute Force Greaseable		UJ232	Brute Force Greaseable		UJ232
Brute Force Non Greaseable		UJ231	Brute Force Non Greaseable		UJ231
(For Aluminum Drive Shaft)		UJ331C	(For Aluminum Drive Shaft)		UJ331C
Clamp Kit (Rr. Shaft; Frt.)		UJ331-10	Clamp Kit (Rr. Shaft; Frt.)		UJ331-10
U-Joint (Rr. Shaft; Rr.)ⓐ		UJ331	U-Joint (Rr. Shaft; Rr.)ⓐ		UJ331
Brute Force Greaseable		UJ232	Brute Force Greaseable		UJ232
Brute Force Non Greaseable		UJ231	Brute Force Non Greaseable		UJ231
(For Aluminum Drive Shaft)		UJ331C	(For Aluminum Drive Shaft)		UJ331C
Clamp Kit (Rr. Shaft; Rr.)		UJ331-10	Clamp Kit (Rr. Shaft; Rr.)		UJ331-10
U-Joint (Wheel Joint)ⓐ	[2]	UJ374	U-Joint (Wheel Joint)ⓐ	[2]	UJ374
Brute Force Non Greaseable		UJ374BF	Brute Force Non Greaseable		UJ374BF
1989-1988 F-350 w/ Frt. Shaft Inner Lock Ring, 136" WB & HD 5 Spd. Man. Trans.: [Type 31]					
U-Joint (Frt. Shaft; Frt.)ⓐ		UJ434			
Brute Force Greaseable		UJ265			
Brute Force Non Greaseable		UJ264			
U-Bolt Kit (Frt. Shaft; Frt.)		UJ534-10			
U-Joint (Frt. Shaft; Ctr.)ⓑ		UJ534G			
Brute Force Greaseable		UJ235			
Brute Force Non Greaseable		UJ234			
U-Joint (Frt. Shaft; Rr.)ⓐ		UJ355			
Brute Force Greaseable		UJ290			
(For Aluminum Drive Shaft)		UJ355C			
U-Joint (Rr. Shaft; Frt.)ⓐ		UJ354			
Brute Force Greaseable		UJ270			
Brute Force Non Greaseable		UJ254			
(For Aluminum Drive Shaft)		UJ354C			
U-Joint (Rr. Shaft; Rr.)ⓐ		UJ434			
Brute Force Greaseable		UJ265			
Brute Force Non Greaseable		UJ264			
U-Bolt Kit (Rr. Shaft; Rr.)		UJ534-10			
U-Joint (Wheel Joint)ⓐ	[2]	UJ374			
Brute Force Non Greaseable		UJ374BF			

(Continued)

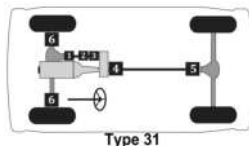

470 ▲ For Use w/ 1.063" Bearing Cap Application. ⓐ For Use w/ 1.188" Bearing Cap Application. ◇ For Use w/ Inner Lock Ring Application on Half Shaft. □ For Use w/ Outer Lock Ring Application on Half Shaft.

MFG./YEAR	MODEL & LOCATION	PART NO.	MFG./YEAR	MODEL & LOCATION	PART NO.
Drive Shaft (4 W/D) (Cont.)			Drive Shaft (4 W/D) (Cont.)		
U-Joint (Cont.)			U-Joint (Cont.)		
1989-1988 F-350 w/ Frt. Shaft Inner Lock Ring & 160" Wheel Base: [Type 32]			1989-1988 F-350 w/ Frt. Shaft Inner Lock Ring, 2 Joint Shaft & 168" Wheel Base: [Type 31]		
	U-Joint (Frt. Shaft; Frt.) ①	UJ434		U-Joint (Frt. Shaft; Frt.) ①	UJ434
	<i>Brute Force Greaseable</i>	UJ265		<i>Brute Force Greaseable</i>	UJ265
	<i>Brute Force Non Greaseable</i>	UJ264		<i>Brute Force Non Greaseable</i>	UJ264
	U-Bolt Kit (Frt. Shaft; Frt.)	UJ534-10		U-Bolt Kit (Frt. Shaft; Frt.)	UJ534-10
	U-Joint (Frt. Shaft; Ctr.) ②	UJ534G		U-Joint (Frt. Shaft; Ctr.) ②	UJ534G
	<i>Brute Force Greaseable</i>	UJ235		<i>Brute Force Greaseable</i>	UJ235
	<i>Brute Force Non Greaseable</i>	UJ234		<i>Brute Force Non Greaseable</i>	UJ234
	U-Joint (Frt. Shaft; Rr.) ③	UJ355		U-Joint (Frt. Shaft; Rr.) ③	UJ355
	<i>Brute Force Greaseable</i>	UJ290		<i>Brute Force Greaseable</i>	UJ290
	(For Aluminum Drive Shaft)	UJ355C		(For Aluminum Drive Shaft)	UJ355C
	U-Joint (Rr. Shaft; Frt.) ④	UJ331		U-Joint (Rr. Shaft; Frt.) ④	UJ331
	<i>Brute Force Greaseable</i>	UJ232		<i>Brute Force Greaseable</i>	UJ232
	<i>Brute Force Non Greaseable</i>	UJ231		<i>Brute Force Non Greaseable</i>	UJ231
	(For Aluminum Drive Shaft)	UJ331C		(For Aluminum Drive Shaft)	UJ331C
	Clamp Kit (Rr. Shaft; Frt.)	UJ331-10		Clamp Kit (Rr. Shaft; Frt.)	UJ331-10
	U-Joint (Rr. Shaft; Ctr.) ⑤	UJ331		U-Joint (Rr. Shaft; Ctr.) ⑤	UJ331
	<i>Brute Force Greaseable</i>	UJ232		<i>Brute Force Greaseable</i>	UJ232
	<i>Brute Force Non Greaseable</i>	UJ231		<i>Brute Force Non Greaseable</i>	UJ231
	(For Aluminum Drive Shaft)	UJ331C		(For Aluminum Drive Shaft)	UJ331C
	Clamp Kit (Rr. Shaft; Ctr.)	UJ331-10		Clamp Kit (Rr. Shaft; Ctr.)	UJ331-10
	U-Joint (Rr. Shaft; Rr.) ⑥	UJ331		U-Joint (Rr. Shaft; Rr.) ⑥	UJ331
	<i>Brute Force Greaseable</i>	UJ232		<i>Brute Force Greaseable</i>	UJ232
	<i>Brute Force Non Greaseable</i>	UJ231		<i>Brute Force Non Greaseable</i>	UJ231
	(For Aluminum Drive Shaft)	UJ331C		(For Aluminum Drive Shaft)	UJ331C
	Clamp Kit (Rr. Shaft; Rr.)	UJ331-10		Clamp Kit (Rr. Shaft; Rr.)	UJ331-10
	U-Joint (Wheel Joint) ⑦	[2] UJ374		U-Joint (Wheel Joint) ⑦	[2] UJ374
	<i>Brute Force Non Greaseable</i>	UJ374BF		<i>Brute Force Non Greaseable</i>	UJ374BF

(Continued)

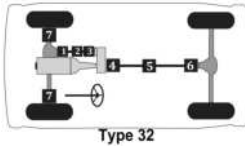
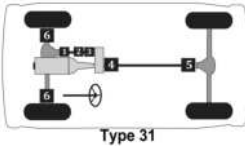

Passenger cars, light & medium trucks

Ford Truck 1 ton -- (Cont.)

MFG./YEAR	MODEL & LOCATION	PART NO.	MFG./YEAR	MODEL & LOCATION	PART NO.
Drive Shaft (4 W/D) (Cont.)			Drive Shaft (4 W/D) (Cont.)		
U-Joint (Cont.)			U-Joint (Cont.)		
1989-1988 F-350 w/ Frt. Shaft Inner Lock Ring, 3 Joint Shaft & 168" Wheel Base: [Typ 32]			1987 F-350 w/ Frt. Shaft Inner Lock Ring, 2 Joint Shaft & Full Time Transfer Case Exc. 5 Spd. Man. Trans.: [Type 31]		
U-Joint (Frt. Shaft; Frt.) ^①		UJ434	U-Joint (Frt. Shaft; Frt.) ^①		UJ434
Brute Force Greaseable		UJ265	Brute Force Greaseable		UJ265
Brute Force Non Greaseable		UJ264	Brute Force Non Greaseable		UJ264
U-Bolt Kit (Frt. Shaft; Frt.)		UJ534-10	U-Bolt Kit (Frt. Shaft; Frt.)		UJ534-10
U-Joint (Frt. Shaft; Ctr.) ^②		UJ534G	U-Joint (Frt. Shaft; Ctr.) ^②		UJ534G
Brute Force Greaseable		UJ235	Brute Force Greaseable		UJ235
Brute Force Non Greaseable		UJ234	Brute Force Non Greaseable		UJ234
U-Joint (Frt. Shaft; Rr.) ^③		UJ355	U-Joint (Frt. Shaft; Rr.) ^③		UJ355
Brute Force Greaseable		UJ290	Brute Force Greaseable		UJ290
(For Aluminum Drive Shaft)		UJ355C	(For Aluminum Drive Shaft)		UJ355C
U-Joint (Rr. Shaft; Frt.) ^④		UJ331	U-Joint (Rr. Shaft; Frt.) ^④		UJ434
Brute Force Greaseable		UJ232	Brute Force Greaseable		UJ265
Brute Force Non Greaseable		UJ231	Brute Force Non Greaseable		UJ264
(For Aluminum Drive Shaft)		UJ331C	U-Bolt Kit (Rr. Shaft; Frt.)		UJ534-10
Clamp Kit (Rr. Shaft; Frt.)		UJ331-10	U-Joint (Rr. Shaft; Rr.) ^⑤		UJ434
U-Joint (Rr. Shaft; Ctr.) ^⑥		UJ331	Brute Force Greaseable		UJ265
Brute Force Greaseable		UJ232	Brute Force Non Greaseable		UJ264
Brute Force Non Greaseable		UJ231	U-Bolt Kit (Rr. Shaft; Rr.)		UJ534-10
(For Aluminum Drive Shaft)		UJ331C	U-Joint (Wheel Joint) ^⑦	[2]	UJ374
Clamp Kit (Rr. Shaft; Ctr.)		UJ331-10	Brute Force Non Greaseable		UJ374BF
U-Joint (Rr. Shaft; Rr.) ^⑧		UJ331			(Continued)
Brute Force Greaseable		UJ232			
Brute Force Non Greaseable		UJ231			
(For Aluminum Drive Shaft)		UJ331C			
Clamp Kit (Rr. Shaft; Rr.)		UJ331-10			
U-Joint (Wheel Joint) ^⑨	[2]	UJ374			
Brute Force Non Greaseable		UJ374BF			

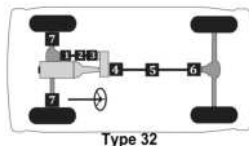
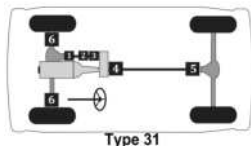

472 ▲ For Use w/ 1.063" Bearing Cap Application. ⊙ For Use w/ 1.188" Bearing Cap Application. ◇ For Use w/ Inner Lock Ring Application on Half Shaft. □ For Use w/ Outer Lock Ring Application on Half Shaft.



Passenger cars, light & medium trucks

(Cont.) -- Ford Truck 1 ton

MFG./YEAR	MODEL & LOCATION	PART NO.	MFG./YEAR	MODEL & LOCATION	PART NO.
Drive Shaft (4 W/D) (Cont.)			Drive Shaft (4 W/D) (Cont.)		
U-Joint (Cont.)			U-Joint (Cont.)		
1987	F-350 w/ Frt. Shaft Inner Lock Ring, 3 Joint Shaft & Full Time Transfer Case Exc. 5 Spd. Man. Trans.: [Type 32]		1987	F-350 w/ Frt. Shaft Inner Lock Ring, 3 Joint Shaft & Part Time Transfer Case Exc. 5 Spd. Man. Trans.: [Type 32]	
	U-Joint (Frt. Shaft; Frt.)①	UJ434		U-Joint (Frt. Shaft; Frt.)①	UJ434
	Brute Force Greaseable	UJ265		Brute Force Greaseable	UJ265
	Brute Force Non Greaseable	UJ264		Brute Force Non Greaseable	UJ264
	U-Bolt Kit (Frt. Shaft; Frt.)	UJ534-10		U-Bolt Kit (Frt. Shaft; Frt.)	UJ534-10
	U-Joint (Frt. Shaft; Ctr.)②	UJ534G		U-Joint (Frt. Shaft; Ctr.)②	UJ534G
	Brute Force Greaseable	UJ235		Brute Force Greaseable	UJ235
	Brute Force Non Greaseable	UJ234		Brute Force Non Greaseable	UJ234
	U-Joint (Frt. Shaft; Rr.)③	UJ355		U-Joint (Frt. Shaft; Rr.)③	UJ355
	Brute Force Greaseable	UJ290		Brute Force Greaseable	UJ290
	(For Aluminum Drive Shaft)	UJ355C		(For Aluminum Drive Shaft)	UJ355C
	U-Joint (Rr. Shaft; Frt.)④	UJ434		U-Joint (Rr. Shaft; Frt.)④	UJ354
	Brute Force Greaseable	UJ265		Brute Force Greaseable	UJ270
	Brute Force Non Greaseable	UJ264		Brute Force Non Greaseable	UJ254
	U-Bolt Kit (Rr. Shaft; Frt.)	UJ534-10		U-Bolt Kit (Rr. Shaft; Frt.)	UJ354C
	U-Joint (Rr. Shaft; Ctr.)⑤	UJ354		U-Joint (Rr. Shaft; Ctr.)⑤	UJ354
	Brute Force Greaseable	UJ270		Brute Force Greaseable	UJ270
	Brute Force Non Greaseable	UJ254		Brute Force Non Greaseable	UJ254
	(For Aluminum Drive Shaft)	UJ354C		(For Aluminum Drive Shaft)	UJ354C
	U-Joint (Rr. Shaft; Rr.)⑥	UJ434		U-Joint (Rr. Shaft; Rr.)⑥	UJ434
	Brute Force Greaseable	UJ265		Brute Force Greaseable	UJ265
	Brute Force Non Greaseable	UJ264		Brute Force Non Greaseable	UJ264
	U-Bolt Kit (Rr. Shaft; Rr.)	UJ534-10		U-Bolt Kit (Rr. Shaft; Rr.)	UJ534-10
	U-Joint (Wheel Joint)⑦	[2] UJ374		U-Joint (Wheel Joint)⑦	[2] UJ374
	Brute Force Non Greaseable	UJ374BF		Brute Force Non Greaseable	UJ374BF
1987	F-350 w/ Frt. Shaft Inner Lock Ring, 2 Joint Shaft & Part Time Transfer Case Exc. 5 Spd. Man. Trans.: [Type 31]				
	U-Joint (Frt. Shaft; Frt.)①	UJ434			
	Brute Force Greaseable	UJ265			
	Brute Force Non Greaseable	UJ264			
	U-Bolt Kit (Frt. Shaft; Frt.)	UJ534-10			
	U-Joint (Frt. Shaft; Ctr.)②	UJ534G			
	Brute Force Greaseable	UJ235			
	Brute Force Non Greaseable	UJ234			
	U-Joint (Frt. Shaft; Rr.)③	UJ355			
	Brute Force Greaseable	UJ290			
	(For Aluminum Drive Shaft)	UJ355C			
	U-Joint (Rr. Shaft; Frt.)④	UJ354			
	Brute Force Greaseable	UJ270			
	Brute Force Non Greaseable	UJ254			
	(For Aluminum Drive Shaft)	UJ354C			
	U-Joint (Rr. Shaft; Rr.)⑤	UJ434			
	Brute Force Greaseable	UJ265			
	Brute Force Non Greaseable	UJ264			
	U-Bolt Kit (Rr. Shaft; Rr.)	UJ534-10			
	U-Joint (Wheel Joint)⑥	[2] UJ374			
	Brute Force Non Greaseable	UJ374BF			

(Continued)

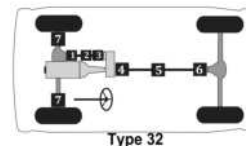
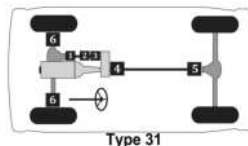

Passenger cars, light & medium trucks

Ford Truck 1 ton -- (Cont.)

MFG./YEAR	MODEL & LOCATION	PART NO.	MFG./YEAR	MODEL & LOCATION	PART NO.
Drive Shaft (4 W/D) (Cont.)			Drive Shaft (4 W/D) (Cont.)		
U-Joint (Cont.)			U-Joint (Cont.)		
1987	F-350 w/ Frt. Shaft Outer Lock Ring, 2 Joint Shaft & Full Time Transfer Case Exc. 5 Spd. Man. Trans.: [Type 26]		1987	F-350 w/ Frt. Shaft Outer Lock Ring, 3 Joint Shaft & Full Time Transfer Case Exc. 5 Spd. Man. Trans.: [Type 27]	
	U-Joint (Frt. Shaft; Frt.) ⓐ	UJ434		U-Joint (Frt. Shaft; Frt.) ⓐ	UJ434
	<i>Brute Force Greaseable</i>	UJ265		<i>Brute Force Greaseable</i>	UJ265
	<i>Brute Force Non Greaseable</i>	UJ264		<i>Brute Force Non Greaseable</i>	UJ264
	U-Bolt Kit (Frt. Shaft; Frt.)	UJ534-10		U-Bolt Kit (Frt. Shaft; Frt.)	UJ534-10
	U-Joint (Frt. Shaft; Rr.) ⓐ	[2] UJ354		U-Joint (Frt. Shaft; Rr.) ⓐ	[2] UJ354
	<i>Brute Force Greaseable</i>	UJ270		<i>Brute Force Greaseable</i>	UJ270
	<i>Brute Force Non Greaseable</i>	UJ254		<i>Brute Force Non Greaseable</i>	UJ254
	(For Aluminum Drive Shaft)	UJ354C		(For Aluminum Drive Shaft)	UJ354C
	U-Joint (Rr. Shaft; Frt.) ⓐ	UJ434		U-Joint (Rr. Shaft; Frt.) ⓐ	UJ434
	<i>Brute Force Greaseable</i>	UJ265		<i>Brute Force Greaseable</i>	UJ265
	<i>Brute Force Non Greaseable</i>	UJ264		<i>Brute Force Non Greaseable</i>	UJ264
	U-Bolt Kit (Rr. Shaft; Frt.)	UJ534-10		U-Bolt Kit (Rr. Shaft; Frt.)	UJ534-10
	U-Joint (Rr. Shaft; Rr.) ⓐ	UJ434		U-Joint (Rr. Shaft; Rr.) ⓐ	UJ354
	<i>Brute Force Greaseable</i>	UJ265		<i>Brute Force Greaseable</i>	UJ270
	<i>Brute Force Non Greaseable</i>	UJ264		<i>Brute Force Non Greaseable</i>	UJ254
	U-Bolt Kit (Rr. Shaft; Rr.)	UJ534-10		(For Aluminum Drive Shaft)	UJ354C
	U-Joint (Wheel Joint) ⓐ	[2] UJ374		U-Joint (Rr. Shaft; Rr.) ⓐ	UJ434
	<i>Brute Force Non Greaseable</i>	UJ374BF		<i>Brute Force Greaseable</i>	UJ265
	Centering Yoke	UJ608		<i>Brute Force Non Greaseable</i>	UJ264
	Weld Yoke	UJ638		U-Bolt Kit (Rr. Shaft; Rr.)	UJ534-10
	H Yoke	UJ648		U-Joint (Wheel Joint) ⓐ	[2] UJ374
				<i>Brute Force Non Greaseable</i>	UJ374BF
				Centering Yoke	UJ608
				Weld Yoke	UJ638
				H Yoke	UJ648

(Continued)

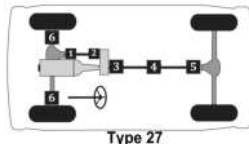
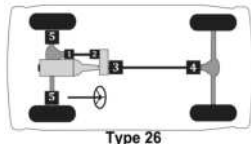

474 ▲ For Use w/ 1.063" Bearing Cap Application. ⓐ For Use w/ 1.188" Bearing Cap Application. ◇ For Use w/ Inner Lock Ring Application on Half Shaft. □ For Use w/ Outer Lock Ring Application on Half Shaft.

MFG./YEAR	MODEL & LOCATION	PART NO.	MFG./YEAR	MODEL & LOCATION	PART NO.
Drive Shaft (4 W/D) (Cont.)			Drive Shaft (4 W/D) (Cont.)		
U-Joint (Cont.)			U-Joint (Cont.)		
1987	F-350 w/ Frt. Shaft Outer Lock Ring, 2 Joint Shaft & Part Time Transfer Case Exc. 5 Spd. Man. Trans.: [Type 26]		1987	F-350 w/ Frt. Shaft Outer Lock Ring, 3 Joint Shaft & Part Time Transfer Case Exc. 5 Spd. Man. Trans.: [Type 27]	
	U-Joint (Frt. Shaft; Frt.) ^①	UJ434		U-Joint (Frt. Shaft; Frt.) ^①	UJ434
	Brute Force Greaseable	UJ265		Brute Force Greaseable	UJ265
	Brute Force Non Greaseable	UJ264		Brute Force Non Greaseable	UJ264
	U-Bolt Kit (Frt. Shaft; Frt.)	UJ534-10		U-Bolt Kit (Frt. Shaft; Frt.)	UJ534-10
	U-Joint (Frt. Shaft; Rr.) ^②	[2] UJ354		U-Joint (Frt. Shaft; Rr.) ^②	[2] UJ354
	Brute Force Greaseable	UJ270		Brute Force Greaseable	UJ270
	Brute Force Non Greaseable	UJ254		Brute Force Non Greaseable	UJ254
	(For Aluminum Drive Shaft)	UJ354C		(For Aluminum Drive Shaft)	UJ354C
	U-Joint (Rr. Shaft; Frt.) ^③	UJ354		U-Joint (Rr. Shaft; Frt.) ^③	UJ354
	Brute Force Greaseable	UJ270		Brute Force Greaseable	UJ270
	Brute Force Non Greaseable	UJ254		Brute Force Non Greaseable	UJ254
	(For Aluminum Drive Shaft)	UJ354C		(For Aluminum Drive Shaft)	UJ354C
	U-Joint (Rr. Shaft; Rr.) ^④	UJ434		U-Joint (Rr. Shaft; Rr.) ^④	UJ434
	Brute Force Greaseable	UJ265		Brute Force Greaseable	UJ270
	Brute Force Non Greaseable	UJ264		Brute Force Non Greaseable	UJ254
	U-Bolt Kit (Rr. Shaft; Rr.)	UJ534-10		U-Bolt Kit (Rr. Shaft; Rr.)	UJ354C
	U-Joint (Wheel Joint) ^⑤	[2] UJ374		U-Joint (Rr. Shaft; Rr.) ^⑤	UJ434
	Brute Force Non Greaseable	UJ374BF		Brute Force Greaseable	UJ265
	Centering Yoke	UJ608		Brute Force Non Greaseable	UJ264
	Weld Yoke	UJ638		U-Bolt Kit (Rr. Shaft; Rr.)	UJ534-10
	H Yoke	UJ648		U-Joint (Wheel Joint) ^⑥	[2] UJ374
				Brute Force Non Greaseable	UJ374BF
				Centering Yoke	UJ608
				Weld Yoke	UJ638
				H Yoke	UJ648

(Continued)

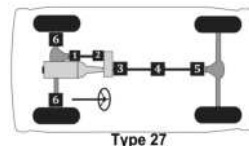
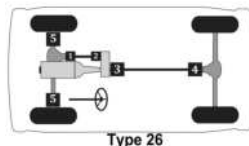

Passenger cars, light & medium trucks

Ford Truck 1 ton -- (Cont.)

MFG./YEAR	MODEL & LOCATION	PART NO.	MFG./YEAR	MODEL & LOCATION	PART NO.
Drive Shaft (4 W/D) (Cont.)			Drive Shaft (4 W/D) (Cont.)		
U-Joint (Cont.)			U-Joint (Cont.)		
1987	F-350 w/ Frt. Shaft Inner Lock Ring, 2 Joint Shaft & 5 Spd. Man. Trans.:		1987	F-350 w/ Frt. Shaft Inner Lock Ring, 3 Joint Shaft & 5 Spd. Man. Trans.:	
	[Type 31]			[Type 32]	
	U-Joint (Frt. Shaft; Frt.) ①	UJ434		U-Joint (Frt. Shaft; Frt.) ①	UJ434
	<i>Brute Force Greaseable</i>	UJ265		<i>Brute Force Greaseable</i>	UJ265
	<i>Brute Force Non Greaseable</i>	UJ264		<i>Brute Force Non Greaseable</i>	UJ264
	U-Bolt Kit (Frt. Shaft; Frt.)	UJ534-10		U-Bolt Kit (Frt. Shaft; Frt.)	UJ534-10
	U-Joint (Frt. Shaft; Ctr.) ②	UJ534G		U-Joint (Frt. Shaft; Ctr.) ②	UJ534G
	<i>Brute Force Greaseable</i>	UJ235		<i>Brute Force Greaseable</i>	UJ235
	<i>Brute Force Non Greaseable</i>	UJ234		<i>Brute Force Non Greaseable</i>	UJ234
	U-Joint (Frt. Shaft; Rr.) ③	UJ355		U-Joint (Frt. Shaft; Rr.) ③	UJ355
	<i>Brute Force Greaseable</i>	UJ290		<i>Brute Force Greaseable</i>	UJ290
	(For Aluminum Drive Shaft)	UJ355C		(For Aluminum Drive Shaft)	UJ355C
	U-Joint (Rr. Shaft; Frt.) ④	UJ331		U-Joint (Rr. Shaft; Frt.) ④	UJ331
	<i>Brute Force Greaseable</i>	UJ232		<i>Brute Force Greaseable</i>	UJ232
	<i>Brute Force Non Greaseable</i>	UJ231		<i>Brute Force Non Greaseable</i>	UJ231
	(For Aluminum Drive Shaft)	UJ331C		(For Aluminum Drive Shaft)	UJ331C
	Clamp Kit (Rr. Shaft; Frt.)	UJ331-10		Clamp Kit (Rr. Shaft; Frt.)	UJ331-10
	U-Joint (Rr. Shaft; Rr.) ⑤	UJ331		U-Joint (Rr. Shaft; Rr.) ⑤	UJ331
	<i>Brute Force Greaseable</i>	UJ232		<i>Brute Force Greaseable</i>	UJ232
	<i>Brute Force Non Greaseable</i>	UJ231		<i>Brute Force Non Greaseable</i>	UJ231
	(For Aluminum Drive Shaft)	UJ331C		(For Aluminum Drive Shaft)	UJ331C
	Clamp Kit (Rr. Shaft; Rr.)	UJ331-10		Clamp Kit (Rr. Shaft; Rr.)	UJ331-10
	U-Joint (Wheel Joint) ⑥	[2] UJ374		U-Joint (Wheel Joint) ⑦	[2] UJ374
	<i>Brute Force Non Greaseable</i>	UJ374BF		<i>Brute Force Non Greaseable</i>	UJ374BF
				(Continued)	

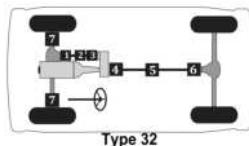
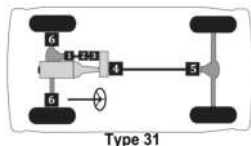

476 ▲ For Use w/ 1.063" Bearing Cap Application. ⊙ For Use w/ 1.188" Bearing Cap Application. ◇ For Use w/ Inner Lock Ring Application on Half Shaft. □ For Use w/ Outer Lock Ring Application on Half Shaft.

MFG./YEAR	MODEL & LOCATION	PART NO.	MFG./YEAR	MODEL & LOCATION	PART NO.
Drive Shaft (4 W/D) (Cont.)			Drive Shaft (4 W/D) (Cont.)		
U-Joint (Cont.)			U-Joint (Cont.)		
1987	F-350 w/ Frt. Shaft Outer Lock Ring, 2 Joint Shaft & 5 Spd. Man. Trans.:		1987	F-350 w/ Frt. Shaft Outer Lock Ring, 3 Joint Shaft & 5 Spd. Man. Trans.:	
	[Type 26]			[Type 27]	
	U-Joint (Frt. Shaft; Frt.) ①	UJ434		U-Joint (Frt. Shaft; Frt.) ①	UJ434
	<i>Brute Force Greaseable</i>	UJ265		<i>Brute Force Greaseable</i>	UJ265
	<i>Brute Force Non Greaseable</i>	UJ264		<i>Brute Force Non Greaseable</i>	UJ264
	U-Bolt Kit (Frt. Shaft; Frt.)	UJ534-10		U-Bolt Kit (Frt. Shaft; Frt.)	UJ534-10
	U-Joint (Frt. Shaft; Rr.) ②	[2] UJ354		U-Joint (Frt. Shaft; Rr.) ②	[2] UJ354
	<i>Brute Force Greaseable</i>	UJ270		<i>Brute Force Greaseable</i>	UJ270
	<i>Brute Force Non Greaseable</i>	UJ254		<i>Brute Force Non Greaseable</i>	UJ254
	(For Aluminum Drive Shaft)	UJ354C		(For Aluminum Drive Shaft)	UJ354C
	U-Joint (Rr. Shaft; Frt.) ③	UJ331		U-Joint (Rr. Shaft; Frt.) ③	UJ331
	<i>Brute Force Greaseable</i>	UJ232		<i>Brute Force Greaseable</i>	UJ232
	<i>Brute Force Non Greaseable</i>	UJ231		<i>Brute Force Non Greaseable</i>	UJ231
	(For Aluminum Drive Shaft)	UJ331C		(For Aluminum Drive Shaft)	UJ331C
	Clamp Kit (Rr. Shaft; Frt.)	UJ331-10		Clamp Kit (Rr. Shaft; Frt.)	UJ331-10
	U-Joint (Rr. Shaft; Rr.) ④	UJ331		U-Joint (Rr. Shaft; Rr.) ④	UJ331
	<i>Brute Force Greaseable</i>	UJ232		<i>Brute Force Greaseable</i>	UJ232
	<i>Brute Force Non Greaseable</i>	UJ231		<i>Brute Force Non Greaseable</i>	UJ231
	(For Aluminum Drive Shaft)	UJ331C		(For Aluminum Drive Shaft)	UJ331C
	Clamp Kit (Rr. Shaft; Rr.)	UJ331-10		Clamp Kit (Rr. Shaft; Rr.)	UJ331-10
	U-Joint (Wheel Joint) ⑤	[2] UJ374		U-Joint (Rr. Shaft; Rr.) ⑤	UJ331
	<i>Brute Force Non Greaseable</i>	UJ374BF		<i>Brute Force Greaseable</i>	UJ232
	Centering Yoke	UJ608		<i>Brute Force Non Greaseable</i>	UJ231
	Weld Yoke	UJ638		(For Aluminum Drive Shaft)	UJ331C
	H Yoke	UJ648		Clamp Kit (Rr. Shaft; Rr.)	UJ331-10
				U-Joint (Wheel Joint) ⑥	[2] UJ374
				<i>Brute Force Non Greaseable</i>	UJ374BF
				Centering Yoke	UJ608
				Weld Yoke	UJ638
				H Yoke	UJ648

(Continued)

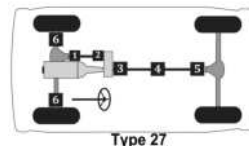
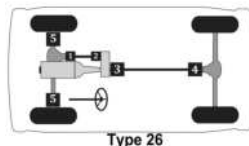

Passenger cars, light & medium trucks

Ford Truck 1 ton -- (Cont.)

MFG./YEAR	MODEL & LOCATION	PART NO.	MFG./YEAR	MODEL & LOCATION	PART NO.
Drive Shaft (4 W/D) (Cont.)			Drive Shaft (4 W/D) (Cont.)		
U-Joint (Cont.)			U-Joint (Cont.)		
1986	F-350 w/ 2 Joint Shaft: [Type 26]		1985	F-350 w/ IFS Front Axle & 2 Joint Rear Shaft: [Type 36]	
U-Joint (Fr. Shaft; Frt.)ⓐ		UJ434	U-Joint (Fr. Shaft; Frt.)ⓐ		UJ434
Brute Force Greaseable		UJ265	Brute Force Greaseable		UJ265
Brute Force Non Greaseable		UJ264	Brute Force Non Greaseable		UJ264
U-Bolt Kit (Fr. Shaft; Frt.)		UJ534-10	U-Bolt Kit (Fr. Shaft; Frt.)		UJ534-10
U-Joint (Fr. Shaft; Rr.)ⓑ	[2]	UJ354	U-Joint (Fr. Shaft; Rr.)ⓑ		UJ434
Brute Force Greaseable		UJ270	Brute Force Greaseable		UJ265
Brute Force Non Greaseable		UJ254	Brute Force Non Greaseable		UJ264
(For Aluminum Drive Shaft)		UJ354C	U-Bolt Kit (Fr. Shaft; Rr.)		UJ534-10
U-Joint (Rr. Shaft; Frt.)ⓐ		UJ434	U-Joint (Rr. Shaft; Frt.)ⓐ		UJ434
Brute Force Greaseable		UJ265	Brute Force Greaseable		UJ265
Brute Force Non Greaseable		UJ264	Brute Force Non Greaseable		UJ264
U-Bolt Kit (Rr. Shaft; Frt.)		UJ534-10	U-Bolt Kit (Rr. Shaft; Frt.)		UJ534-10
U-Joint (Rr. Shaft; Rr.)ⓑ		UJ434	U-Joint (Rr. Shaft; Rr.)ⓑ		UJ434
Brute Force Greaseable		UJ265	Brute Force Greaseable		UJ265
Brute Force Non Greaseable		UJ264	Brute Force Non Greaseable		UJ264
U-Bolt Kit (Rr. Shaft; Rr.)		UJ534-10	U-Bolt Kit (Rr. Shaft; Rr.)		UJ534-10
U-Joint (Wheel Joint)ⓐ	[2]	UJ374	U-Joint (Rr. Shaft; Rr.)ⓐ		UJ434
Brute Force Non Greaseable		UJ374BF	Brute Force Greaseable		UJ265
Centering Yoke		UJ608	Brute Force Non Greaseable		UJ264
H Yoke		UJ648	U-Bolt Kit (Rr. Shaft; Rr.)		UJ534-10
1986	F-350 w/ 3 Joint Shaft: [Type 27]		U-Joint (Front Axle Left Outer)ⓐ		UJ231
U-Joint (Fr. Shaft; Frt.)ⓐ		UJ434	(For Aluminum Drive Shaft)		UJ231C
Brute Force Greaseable		UJ265	U-Joint (Front Axle Right Inner)ⓐ		UJ231
Brute Force Non Greaseable		UJ264	(For Aluminum Drive Shaft)		UJ231C
U-Bolt Kit (Fr. Shaft; Frt.)		UJ534-10	U-Joint (Front Axle Right Outer)ⓑ		UJ231
U-Joint (Fr. Shaft; Rr.)ⓑ	[2]	UJ354	(For Aluminum Drive Shaft)		UJ231C
Brute Force Greaseable		UJ270			(Continued)
Brute Force Non Greaseable		UJ254			
(For Aluminum Drive Shaft)		UJ354C			
U-Joint (Rr. Shaft; Frt.)ⓐ		UJ434			
Brute Force Greaseable		UJ265			
Brute Force Non Greaseable		UJ264			
U-Bolt Kit (Rr. Shaft; Frt.)		UJ534-10			
U-Joint (Rr. Shaft; Ctr.)ⓐ		UJ354			
Brute Force Greaseable		UJ270			
Brute Force Non Greaseable		UJ254			
(For Aluminum Drive Shaft)		UJ354C			
U-Joint (Rr. Shaft; Rr.)ⓐ		UJ434			
Brute Force Greaseable		UJ265			
Brute Force Non Greaseable		UJ264			
U-Bolt Kit (Rr. Shaft; Rr.)		UJ534-10			
U-Joint (Wheel Joint)ⓐ	[2]	UJ374			
Brute Force Non Greaseable		UJ374BF			
Centering Yoke		UJ608			
H Yoke		UJ648			

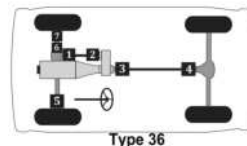
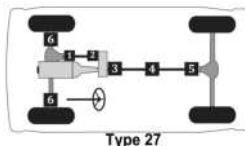
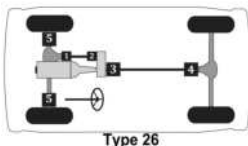

478 ▲ For Use w/ 1.063" Bearing Cap Application. ⓐ For Use w/ 1.188" Bearing Cap Application. ◇ For Use w/ Inner Lock Ring Application on Half Shaft. □ For Use w/ Outer Lock Ring Application on Half Shaft.

MFG./YEAR	MODEL & LOCATION	PART NO.	MFG./YEAR	MODEL & LOCATION	PART NO.
Drive Shaft (4 W/D) (Cont.)			Drive Shaft (4 W/D) (Cont.)		
U-Joint (Cont.)			U-Joint (Cont.)		
1985	F-350 w/ IFS Front Axle & 3 Joint Rear Shaft: [Type 37]		1985	F-350 w/ Monobeam Front Axle & 2 Joint Rear Shaft: [Type 31]	
	U-Joint (Fr. Shaft; Fr.) ①	UJ434		U-Joint (Fr. Shaft; Fr.) ①	UJ354
	<i>Brute Force Greaseable</i>	UJ265		<i>Brute Force Greaseable</i>	UJ270
	<i>Brute Force Non Greaseable</i>	UJ264		<i>Brute Force Non Greaseable</i>	UJ254
	U-Bolt Kit (Fr. Shaft; Fr.)	UJ534-10		(For Aluminum Drive Shaft)	UJ354C
	U-Joint (Fr. Shaft; Rr.) ②	UJ434		U-Joint (Fr. Shaft; Ctr.) ②	UJ354
	<i>Brute Force Greaseable</i>	UJ265		<i>Brute Force Greaseable</i>	UJ270
	<i>Brute Force Non Greaseable</i>	UJ264		<i>Brute Force Non Greaseable</i>	UJ254
	U-Bolt Kit (Fr. Shaft; Rr.)	UJ534-10		(For Aluminum Drive Shaft)	UJ354C
	U-Joint (Rr. Shaft; Fr.) ③	UJ434		U-Joint (Fr. Shaft; Rr.) ③	UJ354
	<i>Brute Force Greaseable</i>	UJ265		<i>Brute Force Greaseable</i>	UJ270
	<i>Brute Force Non Greaseable</i>	UJ264		<i>Brute Force Non Greaseable</i>	UJ254
	U-Bolt Kit (Rr. Shaft; Fr.)	UJ534-10		(For Aluminum Drive Shaft)	UJ354C
	U-Joint (Rr. Shaft; Ctr.) ④	UJ354		U-Joint (Rr. Shaft; Fr.) ④	UJ434
	<i>Brute Force Greaseable</i>	UJ270		<i>Brute Force Greaseable</i>	UJ265
	<i>Brute Force Non Greaseable</i>	UJ254		<i>Brute Force Non Greaseable</i>	UJ264
	(For Aluminum Drive Shaft)	UJ354C		U-Bolt Kit (Rr. Shaft; Fr.)	UJ534-10
	U-Joint (Rr. Shaft; Rr.) ⑤	UJ434		U-Joint (Rr. Shaft; Rr.) ⑤	UJ434
	<i>Brute Force Greaseable</i>	UJ265		<i>Brute Force Greaseable</i>	UJ265
	<i>Brute Force Non Greaseable</i>	UJ264		<i>Brute Force Non Greaseable</i>	UJ264
	U-Bolt Kit (Rr. Shaft; Rr.)	UJ534-10		U-Bolt Kit (Rr. Shaft; Rr.)	UJ534-10
	U-Joint (Front Axle Left Outer) ⑥	UJ231		U-Joint (Wheel Joint) ⑥	[2] UJ374
	(For Aluminum Drive Shaft)	UJ231C		<i>Brute Force Non Greaseable</i>	UJ374BF
	U-Joint (Front Axle Right Inner) ⑦	UJ231		Centering Yoke	UJ608
	(For Aluminum Drive Shaft)	UJ231C		H Yoke	UJ648
	U-Joint (Front Axle Right Outer) ⑧	UJ231			
	(For Aluminum Drive Shaft)	UJ231C			(Continued)

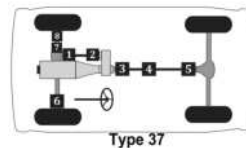
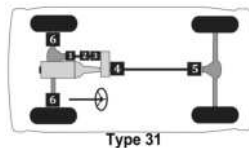

Ford Truck 1 ton -- (Cont.)

MFG./YEAR	MODEL & LOCATION	PART NO.	MFG./YEAR	MODEL & LOCATION	PART NO.
Drive Shaft (4 W/D) (Cont.)			Drive Shaft (4 W/D) (Cont.)		
U-Joint (Cont.)			U-Joint (Cont.)		
1985	F-350 w/ Monobeam Front Axle & 3 Joint Rear Shaft: [Type 32]		1984-1982	F-350 w/ 2 Joint Shaft: [Type 36]	
	U-Joint (Fr. Shaft; Frt.) ⊙	UJ354		U-Joint (Fr. Shaft; Frt.) ⊙	UJ434
	<i>Brute Force Greaseable</i>	UJ270		<i>Brute Force Greaseable</i>	UJ265
	<i>Brute Force Non Greaseable</i>	UJ254		<i>Brute Force Non Greaseable</i>	UJ264
	(For Aluminum Drive Shaft)	UJ354C		U-Bolt Kit (Fr. Shaft; Frt.)	UJ534-10
	U-Joint (Fr. Shaft; Ctr.) ⊙	UJ354		U-Joint (Fr. Shaft; Rr.) ⊙	UJ434
	<i>Brute Force Greaseable</i>	UJ270		<i>Brute Force Greaseable</i>	UJ265
	<i>Brute Force Non Greaseable</i>	UJ254		<i>Brute Force Non Greaseable</i>	UJ264
	(For Aluminum Drive Shaft)	UJ354C		U-Bolt Kit (Fr. Shaft; Rr.)	UJ534-10
	U-Joint (Rr. Shaft; Frt.) ⊙	UJ354		U-Joint (Rr. Shaft; Frt.) ⊙	UJ434
	<i>Brute Force Greaseable</i>	UJ270		<i>Brute Force Greaseable</i>	UJ265
	<i>Brute Force Non Greaseable</i>	UJ254		<i>Brute Force Non Greaseable</i>	UJ264
	(For Aluminum Drive Shaft)	UJ354C		U-Bolt Kit (Rr. Shaft; Frt.)	UJ534-10
	U-Joint (Rr. Shaft; Rr.) ⊙	UJ434		U-Joint (Rr. Shaft; Rr.) ⊙	UJ434
	<i>Brute Force Greaseable</i>	UJ265		<i>Brute Force Greaseable</i>	UJ265
	<i>Brute Force Non Greaseable</i>	UJ264		<i>Brute Force Non Greaseable</i>	UJ264
	U-Bolt Kit (Rr. Shaft; Rr.)	UJ534-10		U-Bolt Kit (Rr. Shaft; Rr.)	UJ534-10
	U-Joint (Rr. Shaft; Ctr.) ⊙	UJ354		U-Joint (Front Axle Left Outer) ⊙	UJ231
	<i>Brute Force Greaseable</i>	UJ270		(For Aluminum Drive Shaft)	UJ231C
	<i>Brute Force Non Greaseable</i>	UJ254		U-Joint (Front Axle Right Inner) ⊙	UJ231
	(For Aluminum Drive Shaft)	UJ354C		(For Aluminum Drive Shaft)	UJ231C
	U-Joint (Rr. Shaft; Rr.) ⊙	UJ434		U-Joint (Front Axle Right Outer) ⊙	UJ231
	<i>Brute Force Greaseable</i>	UJ265		(For Aluminum Drive Shaft)	UJ231C
	<i>Brute Force Non Greaseable</i>	UJ264			(Continued)
	U-Bolt Kit (Rr. Shaft; Rr.)	UJ534-10			
	U-Joint (Wheel Joint) ⊙	[2] UJ374			
	<i>Brute Force Non Greaseable</i>	UJ374BF			
	Centering Yoke	UJ608			

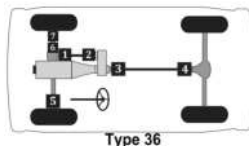
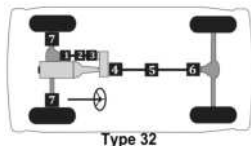

480 ▲ For Use w/ 1.063" Bearing Cap Application. ⊙ For Use w/ 1.188" Bearing Cap Application. ◇ For Use w/ Inner Lock Ring Application on Half Shaft. □ For Use w/ Outer Lock Ring Application on Half Shaft.

MFG./YEAR	MODEL & LOCATION	PART NO.	MFG./YEAR	MODEL & LOCATION	PART NO.
Drive Shaft (4 W/D) (Cont.)			Drive Shaft (4 W/D) (Cont.)		
U-Joint (Cont.)			U-Joint (Cont.)		
1984-1982 F-350 w/ 3 Joint Shaft: [Type 37]			1981-1980 F-350 w/ Front Axle Inner Lock Rings:		
				[Type 36]	
	U-Joint (Fr. Shaft; Fr.) ①	UJ434		U-Joint (Fr. Shaft; Fr.) ①	UJ354
	<i>Brute Force Greaseable</i>	UJ265		<i>Brute Force Greaseable</i>	UJ270
	<i>Brute Force Non Greaseable</i>	UJ264		<i>Brute Force Non Greaseable</i>	UJ254
	U-Bolt Kit (Fr. Shaft; Fr.)	UJ534-10		(For Aluminum Drive Shaft)	UJ354C
	U-Joint (Fr. Shaft; Rr.) ②	UJ434		U-Joint (Fr. Shaft; Rr.) ②	UJ434
	<i>Brute Force Greaseable</i>	UJ265		<i>Brute Force Greaseable</i>	UJ265
	<i>Brute Force Non Greaseable</i>	UJ264		<i>Brute Force Non Greaseable</i>	UJ264
	U-Bolt Kit (Fr. Shaft; Rr.)	UJ534-10		U-Bolt Kit (Fr. Shaft; Rr.)	UJ534-10
	U-Joint (Rr. Shaft; Fr.) ③	UJ434		U-Joint (Rr. Shaft; Fr.) ③	UJ354
	<i>Brute Force Greaseable</i>	UJ265		<i>Brute Force Greaseable</i>	UJ270
	<i>Brute Force Non Greaseable</i>	UJ264		<i>Brute Force Non Greaseable</i>	UJ254
	U-Bolt Kit (Rr. Shaft; Fr.)	UJ534-10		(For Aluminum Drive Shaft)	UJ354C
	U-Joint (Rr. Shaft; Ctr.) ④	UJ354		U-Joint (Rr. Shaft; Rr.) ⑤	UJ434
	<i>Brute Force Greaseable</i>	UJ270		<i>Brute Force Greaseable</i>	UJ265
	<i>Brute Force Non Greaseable</i>	UJ254		<i>Brute Force Non Greaseable</i>	UJ264
	(For Aluminum Drive Shaft)	UJ354C		U-Bolt Kit (Rr. Shaft; Rr.)	UJ534-10
	U-Joint (Rr. Shaft; Rr.) ⑥	UJ434		U-Joint (Front Axle Left Outer) ⑦	UJ371
	<i>Brute Force Greaseable</i>	UJ265		<i>Brute Force Greaseable</i>	UJ377
	<i>Brute Force Non Greaseable</i>	UJ264		<i>Brute Force Non Greaseable</i>	UJ371
	U-Bolt Kit (Rr. Shaft; Rr.)	UJ534-10		U-Joint (Front Axle Right Inner) ⑧	UJ371
	U-Joint (Front Axle Left Outer) ⑥	UJ231		<i>Brute Force Greaseable</i>	UJ377
	(For Aluminum Drive Shaft)	UJ231C		<i>Brute Force Non Greaseable</i>	UJ371
	U-Joint (Front Axle Right Inner) ⑦	UJ231		U-Joint (Front Axle Right Outer) ⑨	UJ371
	(For Aluminum Drive Shaft)	UJ231C		<i>Brute Force Greaseable</i>	UJ377
	U-Joint (Front Axle Right Outer) ⑧	UJ231		<i>Brute Force Non Greaseable</i>	UJ371
	(For Aluminum Drive Shaft)	UJ231C			

(Continued)

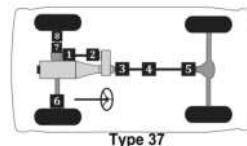
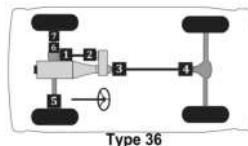

Passenger cars, light & medium trucks

Ford Truck 1 ton -- (Cont.)

MFG./YEAR	MODEL & LOCATION	PART NO.	MFG./YEAR	MODEL & LOCATION	PART NO.
-----------	------------------	----------	-----------	------------------	----------

Drive Shaft (4 W/D) (Cont.)

U-Joint (Cont.)

1981-1980 F-350 w/ Front Axle Outer Lock Rings:

[Type 36]

U-Joint (Fr. Shaft; Fr.) [Ⓢ]	UJ354
Brute Force Greaseable	UJ270
Brute Force Non Greaseable	UJ254
(For Aluminum Drive Shaft)	UJ354C
U-Joint (Fr. Shaft; Rr.) [Ⓢ]	UJ434
Brute Force Greaseable	UJ265
Brute Force Non Greaseable	UJ264
U-Bolt Kit (Fr. Shaft; Rr.)	UJ534-10
U-Joint (Rr. Shaft; Fr.) [Ⓢ]	UJ354
Brute Force Greaseable	UJ270
Brute Force Non Greaseable	UJ254
(For Aluminum Drive Shaft)	UJ354C
U-Joint (Rr. Shaft; Rr.) [Ⓢ]	UJ434
Brute Force Greaseable	UJ265
Brute Force Non Greaseable	UJ264
U-Bolt Kit (Rr. Shaft; Rr.)	UJ534-10
U-Joint (Front Axle Left Outer) [Ⓢ]	UJ231
(For Aluminum Drive Shaft)	UJ231C
U-Joint (Front Axle Right Inner) [Ⓢ]	UJ231
(For Aluminum Drive Shaft)	UJ231C
U-Joint (Front Axle Right Outer) [Ⓢ]	UJ231
(For Aluminum Drive Shaft)	UJ231C

Drive Shaft (4 W/D) (Cont.)

U-Joint (Cont.)

1979 F-350 w/ 2 Joint Shaft: [Type 26]

U-Joint (Fr. Shaft; Fr.) [Ⓢ]	UJ434
Brute Force Greaseable	UJ265
Brute Force Non Greaseable	UJ264
U-Bolt Kit (Fr. Shaft; Fr.)	UJ534-10
U-Joint (Fr. Shaft; Rr.) [Ⓢ]	[2] UJ354
Brute Force Greaseable	UJ270
Brute Force Non Greaseable	UJ254
(For Aluminum Drive Shaft)	UJ354C
U-Joint (Rr. Shaft; Fr.) [Ⓢ]	UJ354
Brute Force Greaseable	UJ270
Brute Force Non Greaseable	UJ254
(For Aluminum Drive Shaft)	UJ354C
U-Joint (Rr. Shaft; Rr.) [Ⓢ]	UJ434
Brute Force Greaseable	UJ265
Brute Force Non Greaseable	UJ264
U-Bolt Kit (Rr. Shaft; Rr.)	UJ534-10
U-Joint (Wheel Joint) [Ⓢ]	[2] UJ374
Brute Force Non Greaseable	UJ374BF
Centering Yoke	UJ608
Weld Yoke	UJ638
H Yoke	UJ648

(Continued)

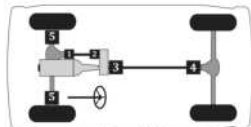

Type 26

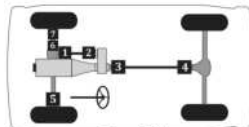

Type 36

Passenger cars, light & medium trucks

(Cont.) -- Ford Truck 1 ton

MFG./YEAR	MODEL & LOCATION	PART NO.	MFG./YEAR	MODEL & LOCATION	PART NO.
Drive Shaft (4 W/D) (Cont.) U-Joint (Cont.)			Drive Shaft (4 W/D) (Cont.) U-Joint (Cont.)		
			1979 F-350 w/ 3 Joint Shaft: [Type 27]		
			U-Joint (Frt. Shaft; Frt.) ①		
			Brute Force Greaseable UJ434		
			Brute Force Non Greaseable UJ265		
			U-Bolt Kit (Frt. Shaft; Frt.) UJ534-10		
			U-Joint (Frt. Shaft; Rr.) ②		
			Brute Force Greaseable [2] UJ354		
			Brute Force Non Greaseable UJ270		
			(For Aluminum Drive Shaft) UJ254		
			U-Joint (Rr. Shaft; Frt.) ③		
			Brute Force Greaseable UJ354		
			Brute Force Non Greaseable UJ270		
			(For Aluminum Drive Shaft) UJ254		
			U-Joint (Rr. Shaft; Ctr.) ④		
			Brute Force Greaseable UJ354		
			Brute Force Non Greaseable UJ270		
			(For Aluminum Drive Shaft) UJ254		
			U-Joint (Rr. Shaft; Rr.) ⑤		
			Brute Force Greaseable UJ434		
			Brute Force Non Greaseable UJ265		
			U-Bolt Kit (Rr. Shaft; Rr.) UJ534-10		
			U-Joint (Wheel Joint) ⑥		
			Brute Force Non Greaseable [2] UJ374		
			Brute Force Non Greaseable UJ374BF		

Ford Truck 1 1/2 ton, 2 1/2 ton

Drive Shaft (4 X 2) U-Joint			Drive Shaft (4 X 2) (Cont.) U-Joint (Cont.)		
2020-1999 F-450 & F-550 w/ 3 Joint Shaft: [Type 2]			2020-1999 F-450 & F-550 w/ 4 Joint Shaft: [Type 3]		
U-Joint (Front) ①			U-Joint (Front) ①		
(For Aluminum Drive Shaft) UJ351			(For Aluminum Drive Shaft) UJ351		
Brute Force Non Greaseable UJ351C			Brute Force Non Greaseable UJ351C		
Clamp Kit (Front) UJ351BF			Clamp Kit (Front) UJ351BF		
U-Joint (Center) ②			U-Joint (Center; Front) ②		
(For Aluminum Drive Shaft) UJ351			(For Aluminum Drive Shaft) UJ351		
Brute Force Non Greaseable UJ351C			Brute Force Non Greaseable UJ351C		
Clamp Kit (Center) UJ351BF			Clamp Kit (Center; Front) UJ351BF		
Clamp Kit (Center) UJ351-10			Clamp Kit (Center; Front) UJ351-10		
U-Joint (Rear) ③			U-Joint (Center; Rear) ③		
(For Aluminum Drive Shaft) UJ351			(For Aluminum Drive Shaft) UJ351		
Brute Force Non Greaseable UJ351C			Brute Force Non Greaseable UJ351C		
Clamp Kit (Rear) UJ351BF			Clamp Kit (Center; Rear) UJ351BF		
Clamp Kit (Rear) UJ351-10			Clamp Kit (Center; Rear) UJ351-10		
			U-Joint (Rear) ④		
			(For Aluminum Drive Shaft) UJ351		
			Brute Force Non Greaseable UJ351C		
			Brute Force Non Greaseable UJ351BF		
			Clamp Kit (Rear) UJ351-10		
			Clamp Kit (Rear) UJ351-10		
			(Continued)		

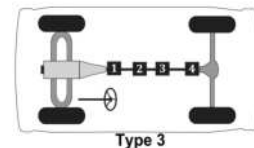
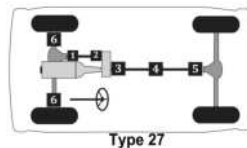
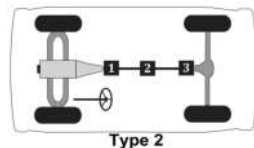

Passenger cars, light & medium trucks

Ford Truck 1 1/2 ton, 2 1/2 ton -- (Cont.)

MFG./YEAR	MODEL & LOCATION	PART NO.	MFG./YEAR	MODEL & LOCATION	PART NO.
Drive Shaft (4 X 4)			Drive Shaft (4 X 4) (Cont.)		
U-Joint			U-Joint (Cont.)		
2020-2009 F-450 & F-550 w/ 2 Joint Shaft: [Type 28]			2008-2005 F-450 & F-550 w/ 3 Joint Shaft: [Type 29]		
U-Joint (Fr. Shaft; Frt.)Ⓚ		UJ330	U-Joint (Fr. Shaft; Frt.)Ⓚ		UJ331
Brute Force Greaseable		UJ295	Brute Force Greaseable		UJ232
(For Aluminum Drive Shaft)		UJ330C	Brute Force Non Greaseable		UJ231
Clamp Kit (Fr. Shaft; Frt.)		UJ331-10	(For Aluminum Drive Shaft)		UJ331C
U-Joint (Rr. Shaft; Frt.)Ⓛ		UJ351	Clamp Kit (Fr. Shaft; Frt.)		UJ331-10
(For Aluminum Drive Shaft)		UJ351C	U-Joint (Rr. Shaft; Frt.)Ⓛ		UJ351
Brute Force Non Greaseable		UJ351BF	(For Aluminum Drive Shaft)		UJ351C
Clamp Kit (Rr. Shaft; Frt.)		UJ351-10	Brute Force Non Greaseable		UJ351BF
U-Joint (Rr. Shaft; Rr.)Ⓛ		UJ351	Clamp Kit (Rr. Shaft; Frt.)		UJ351-10
(For Aluminum Drive Shaft)		UJ351C	U-Joint (Rr. Shaft; Rr.)Ⓛ		UJ351
Brute Force Non Greaseable		UJ351BF	(For Aluminum Drive Shaft)		UJ351C
Clamp Kit (Rr. Shaft; Rr.)		UJ351-10	Brute Force Non Greaseable		UJ351BF
U-Joint (Wheel Joint)Ⓛ	[2]	UJ424	Clamp Kit (Rr. Shaft; Ctr.)		UJ351-10
2020-2009 F-450 & F-550 w/ 3 Joint Shaft: [Type 29]			U-Joint (Rr. Shaft; Rr.)Ⓛ		UJ351
U-Joint (Fr. Shaft; Frt.)Ⓚ		UJ330	(For Aluminum Drive Shaft)		UJ351C
Brute Force Greaseable		UJ295	Brute Force Non Greaseable		UJ351BF
(For Aluminum Drive Shaft)		UJ330C	Clamp Kit (Rr. Shaft; Rr.)		UJ351-10
Clamp Kit (Fr. Shaft; Frt.)		UJ331-10	U-Joint (Wheel Joint)Ⓛ	[2]	UJ424
U-Joint (Rr. Shaft; Frt.)Ⓛ		UJ351	2004-1999 F-450 & F-550 w/ 2 Joint Shaft: [Type 26]		
(For Aluminum Drive Shaft)		UJ351C	U-Joint (Fr. Shaft; Frt.)Ⓚ		UJ331
Brute Force Non Greaseable		UJ351BF	Brute Force Greaseable		UJ232
Clamp Kit (Rr. Shaft; Frt.)		UJ351-10	Brute Force Non Greaseable		UJ231
U-Joint (Rr. Shaft; Ctr.)Ⓛ		UJ351	(For Aluminum Drive Shaft)		UJ331C
(For Aluminum Drive Shaft)		UJ351C	Clamp Kit (Fr. Shaft; Frt.)		UJ331-10
Brute Force Non Greaseable		UJ351BF	U-Joint (Fr. Shaft; Rr.)Ⓛ	[2]	UJ331
Clamp Kit (Rr. Shaft; Ctr.)		UJ351-10	Brute Force Greaseable		UJ232
U-Joint (Rr. Shaft; Rr.)Ⓛ		UJ351	Brute Force Non Greaseable		UJ231
(For Aluminum Drive Shaft)		UJ351C	(For Aluminum Drive Shaft)		UJ331C
Brute Force Non Greaseable		UJ351BF	Clamp Kit (Fr. Shaft; Rr.)		UJ331-10
Clamp Kit (Rr. Shaft; Rr.)		UJ351-10	U-Joint (Rr. Shaft; Frt.)Ⓛ		UJ351
U-Joint (Wheel Joint)Ⓛ	[2]	UJ424	(For Aluminum Drive Shaft)		UJ351C
2008-2005 F-450 & F-550 w/ 2 Joint Shaft: [Type 28]			Brute Force Non Greaseable		UJ351BF
U-Joint (Fr. Shaft; Frt.)Ⓚ		UJ331	Clamp Kit (Rr. Shaft; Frt.)		UJ351-10
Brute Force Greaseable		UJ232	U-Joint (Rr. Shaft; Rr.)Ⓛ		UJ351
Brute Force Non Greaseable		UJ231	(For Aluminum Drive Shaft)		UJ351C
(For Aluminum Drive Shaft)		UJ331C	Brute Force Non Greaseable		UJ351BF
Clamp Kit (Fr. Shaft; Frt.)		UJ331-10	Clamp Kit (Rr. Shaft; Rr.)		UJ351-10
U-Joint (Rr. Shaft; Frt.)Ⓛ		UJ351	Ball Seat Repair Kit		UJ606
(For Aluminum Drive Shaft)		UJ351C	U-Joint (Wheel Joint)Ⓛ	[2]	UJ374
Brute Force Non Greaseable		UJ351BF	Brute Force Non Greaseable		UJ374BF
Clamp Kit (Rr. Shaft; Frt.)		UJ351-10	Flange Yoke		UJ630F
U-Joint (Rr. Shaft; Rr.)Ⓛ		UJ351	H Yoke		UJ650
(For Aluminum Drive Shaft)		UJ351C			(Continued)
Brute Force Non Greaseable		UJ351BF			
Clamp Kit (Rr. Shaft; Rr.)		UJ351-10			
U-Joint (Wheel Joint)Ⓛ	[2]	UJ424			

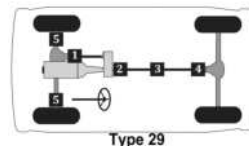
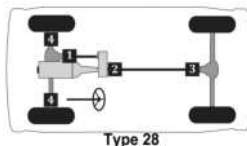
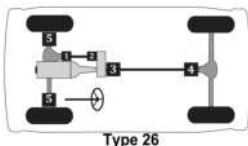

Passenger cars, light & medium trucks

(Cont.) -- Ford Truck 1 1/2 ton, 2 1/2 ton

MFG./YEAR	MODEL & LOCATION	PART NO.	MFG./YEAR	MODEL & LOCATION	PART NO.
Drive Shaft (4 X 4) (Cont.) U-Joint (Cont.)			Drive Shaft (4 X 4) (Cont.) U-Joint (Cont.)		
			2004-1999 F-450 & F-550 w/ 3 Joint Shaft: [Type 27]		
			U-Joint (Frnt. Shaft; Frt.)① UJ331		
			Brute Force Greaseable UJ232		
			Brute Force Non Greaseable UJ231		
			(For Aluminum Drive Shaft) UJ331C		
			Clamp Kit (Frnt. Shaft; Frt.) UJ331-10		
			U-Joint (Frnt. Shaft; Rr.)② [2] UJ331		
			Brute Force Greaseable UJ232		
			Brute Force Non Greaseable UJ231		
			(For Aluminum Drive Shaft) UJ331C		
			Clamp Kit (Frnt. Shaft; Rr.) UJ331-10		
			U-Joint (Rr. Shaft; Frt.)③ UJ351		
			(For Aluminum Drive Shaft) UJ351C		
			Brute Force Non Greaseable UJ351BF		
			Clamp Kit (Rr. Shaft; Frt.) UJ351-10		
			U-Joint (Rr. Shaft; Ctr.)④ UJ351		
			(For Aluminum Drive Shaft) UJ351C		
			Brute Force Non Greaseable UJ351BF		
			Clamp Kit (Rr. Shaft; Ctr.) UJ351-10		
			U-Joint (Rr. Shaft; Rr.)⑤ UJ351		
			(For Aluminum Drive Shaft) UJ351C		
			Brute Force Non Greaseable UJ351BF		
			Clamp Kit (Rr. Shaft; Rr.) UJ374BF		

Geo Tracker (1989-1997), (from 1998) See-Chevrolet/GMC Truck

Drive Shaft (2 W/D) U-Joint			Drive Shaft (4 W/D) U-Joint		
1997-1989 Tracker: [Type 1]			1997-1989 Tracker: [Type 13]		
U-Joint (Front)① UJ398			U-Joint (Frnt. Shaft; Frt.)① UJ398		
U-Joint (Rear)② UJ398			U-Joint (Frnt. Shaft; Rr.)② UJ398		
			U-Joint (Rr. Shaft; Frt.)③ UJ398		
			U-Joint (Rr. Shaft; Rr.)④ UJ398		

Hino Truck 145, 165

Drive Shaft U-Joint			Drive Shaft (Cont.) U-Joint (Cont.)		
2007-2005 145 & 165 w/ 3 Joint Shaft: [Type 2]			2007-2005 145 & 165 w/ 4 Joint Shaft: [Type 3]		
U-Joint (Front)① UJ358			U-Joint (Front)① UJ358		
Brute Force Non Greaseable UJ358BF			Brute Force Non Greaseable UJ358BF		
U-Joint (Center)② UJ358			U-Joint (Center; Front)② UJ358		
Brute Force Non Greaseable UJ358BF			Brute Force Non Greaseable UJ358BF		
U-Joint (Rear)③ UJ358			U-Joint (Center; Rear)③ UJ358		
Brute Force Non Greaseable UJ358BF			Brute Force Non Greaseable UJ358BF		
			U-Joint (Rear)④ UJ358		
			Brute Force Non Greaseable UJ358BF		

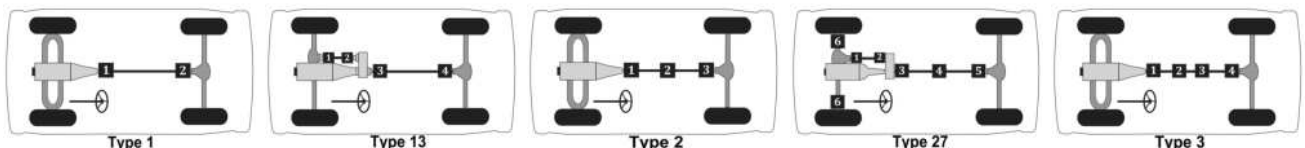

Passenger cars, light & medium trucks

Hino Truck 185

MFG./YEAR	MODEL & LOCATION	PART NO.	MFG./YEAR	MODEL & LOCATION	PART NO.
Drive Shaft			Drive Shaft (Cont.)		
U-Joint			U-Joint (Cont.)		
2007-2005 185 w/ 3 Joint Shaft: [Type 2]			2007-2005 185 w/ 4 Joint Shaft: [Type 3]		
U-Joint (Front)①		UJ358	U-Joint (Front)①		UJ358
Brute Force Non Greaseable		UJ358BF	Brute Force Non Greaseable		UJ358BF
U-Joint (Center)②		UJ358	U-Joint (Center; Front)②		UJ358
Brute Force Non Greaseable		UJ358BF	Brute Force Non Greaseable		UJ358BF
U-Joint (Rear)③		UJ358	U-Joint (Center; Rear)③		UJ358
Brute Force Non Greaseable		UJ358BF	Brute Force Non Greaseable		UJ358BF
			U-Joint (Rear)④		UJ358
			Brute Force Non Greaseable		UJ358BF

Hino Truck 238

Drive Shaft	
U-Joint	
2007-2005 238 w/ 3 Joint Shaft: [Type 2]	
U-Joint (Front)①	UJ460
U-Joint (Center)②	UJ460
U-Joint (Rear)③	UJ460
2007-2005 238 w/ 4 Joint Shaft: [Type 3]	
U-Joint (Front)①	UJ460
U-Joint (Center; Front)②	UJ460
U-Joint (Center; Rear)③	UJ460
U-Joint (Rear)④	UJ460

Hino Truck 258LP

Drive Shaft	
U-Joint	
2007-2006 258LP w/ 3 Joint Shaft: [Type 2]	
U-Joint (Front)①	UJ460
U-Joint (Center)②	UJ460
U-Joint (Rear)③	UJ460
2007-2006 258LP w/ 4 Joint Shaft: [Type 3]	
U-Joint (Front)①	UJ460
U-Joint (Center; Front)②	UJ460
U-Joint (Center; Rear)③	UJ460
U-Joint (Rear)④	UJ460

Hino Truck 268

Drive Shaft	
U-Joint	
2007-2005 268 w/ 3 Joint Shaft: [Type 2]	
U-Joint (Front)①	UJ460
U-Joint (Center)②	UJ460
U-Joint (Rear)③	UJ460
2007-2005 268 w/ 4 Joint Shaft: [Type 3]	
U-Joint (Front)①	UJ460
U-Joint (Center; Front)②	UJ460
U-Joint (Center; Rear)③	UJ460
U-Joint (Rear)④	UJ460

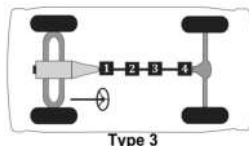
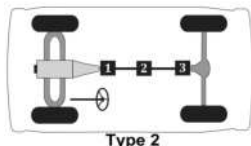

MFG./YEAR	MODEL & LOCATION	PART NO.	MFG./YEAR	MODEL & LOCATION	PART NO.
Drive Shaft (2 W/D)			Drive Shaft (4 W/D)		
U-Joint			U-Joint		
2002-1998 Passport: [Type 1]			2002-1998 Passport: [Type 13]		
	U-Joint (Front) ❶	UJ369		U-Joint (Fr. Shaft; Frt.) ❶	UJ369
	<i>Brute Force Greaseable</i>	UJ280		<i>Brute Force Greaseable</i>	UJ280
	<i>Brute Force Non Greaseable</i>	UJ269		<i>Brute Force Non Greaseable</i>	UJ269
	(For Aluminum Drive Shaft)	UJ369C		(For Aluminum Drive Shaft)	UJ369C
	Clamp Kit (Front)	UJ437-10		Clamp Kit (Fr. Shaft; Frt.)	UJ437-10
	U-Joint (Rear) ❷	UJ369		U-Joint (Fr. Shaft; Rr.) ❷	UJ369
	<i>Brute Force Greaseable</i>	UJ280		<i>Brute Force Greaseable</i>	UJ280
	<i>Brute Force Non Greaseable</i>	UJ269		<i>Brute Force Non Greaseable</i>	UJ269
	(For Aluminum Drive Shaft)	UJ369C		(For Aluminum Drive Shaft)	UJ369C
	Clamp Kit (Rear)	UJ437-10		Clamp Kit (Fr. Shaft; Rr.)	UJ437-10
	1997-1994 Passport: [Type 2]			U-Joint (Rr. Shaft; Frt.) ❸	UJ369
	U-Joint (Front) ❶	UJ369		<i>Brute Force Greaseable</i>	UJ280
	<i>Brute Force Greaseable</i>	UJ280		<i>Brute Force Non Greaseable</i>	UJ269
	<i>Brute Force Non Greaseable</i>	UJ269		(For Aluminum Drive Shaft)	UJ369C
	(For Aluminum Drive Shaft)	UJ369C		Clamp Kit (Rr. Shaft; Frt.)	UJ437-10
	Clamp Kit (Front)	UJ437-10		U-Joint (Rr. Shaft; Rr.) ❹	UJ369
	U-Joint (Center) ❸	UJ369		<i>Brute Force Greaseable</i>	UJ280
	<i>Brute Force Greaseable</i>	UJ280		<i>Brute Force Non Greaseable</i>	UJ269
	<i>Brute Force Non Greaseable</i>	UJ269		(For Aluminum Drive Shaft)	UJ369C
	(For Aluminum Drive Shaft)	UJ369C		Clamp Kit (Rr. Shaft; Rr.)	UJ437-10
	Clamp Kit (Center)	UJ437-10		1997-1994 Passport: [Type 14]	
	U-Joint (Rear) ❷	UJ369		U-Joint (Fr. Shaft; Frt.) ❶	UJ383
	<i>Brute Force Greaseable</i>	UJ280		U-Joint (Fr. Shaft; Rr.) ❷	UJ383
	<i>Brute Force Non Greaseable</i>	UJ269		U-Joint (Rr. Shaft; Frt.) ❸	UJ369
	(For Aluminum Drive Shaft)	UJ369C		<i>Brute Force Greaseable</i>	UJ280
	Clamp Kit (Rear)	UJ437-10		<i>Brute Force Non Greaseable</i>	UJ269
				(For Aluminum Drive Shaft)	UJ369C
				Clamp Kit (Rr. Shaft; Frt.)	UJ437-10
				U-Joint (Rr. Shaft; Ctr.) ❹	UJ369
				<i>Brute Force Greaseable</i>	UJ280
				<i>Brute Force Non Greaseable</i>	UJ269
				(For Aluminum Drive Shaft)	UJ369C
				Clamp Kit (Rr. Shaft; Ctr.)	UJ437-10
				U-Joint (Rr. Shaft; Rr.) ❸	UJ369
				<i>Brute Force Greaseable</i>	UJ280
				<i>Brute Force Non Greaseable</i>	UJ269
				(For Aluminum Drive Shaft)	UJ369C
				Clamp Kit (Rr. Shaft; Rr.)	UJ437-10

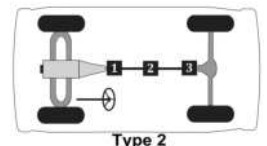
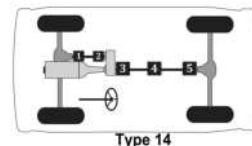
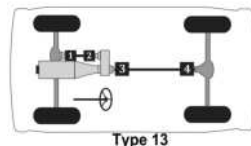
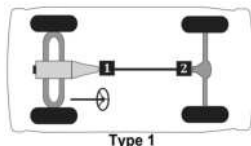

Hummer H1, H2, H3

MFG./YEAR	MODEL & LOCATION	PART NO.	MFG./YEAR	MODEL & LOCATION	PART NO.
-----------	------------------	----------	-----------	------------------	----------

Drive Shaft (4 W/D)

U-Joint

2009-2006 H3 & H3T: [Type 15]

U-Joint (Fr. Shaft; Frt.) ^①	UJ445
Brute Force Greaseable	UJ225
Clamp Kit (Fr. Shaft; Frt.)	UJ360-10
U-Joint (Rr. Shaft; Frt.) ^②	UJ331A
Brute Force Greaseable	UJ232A
Clamp Kit (Rr. Shaft; Frt.)	UJ492-10
U-Joint (Rr. Shaft; Rr.) ^③	UJ331A
Brute Force Greaseable	UJ232A
Clamp Kit (Rr. Shaft; Rr.)	UJ492-10

2009-2003 H2: [Type 13]

U-Joint (Fr. Shaft; Frt.) ^①	UJ534G
Brute Force Greaseable	UJ235
Brute Force Non Greaseable	UJ234
Clamp Kit (Fr. Shaft; Frt.)	UJ530-10
U-Joint (Fr. Shaft; Rr.) ^②	UJ534G
Brute Force Greaseable	UJ235
Brute Force Non Greaseable	UJ234
Clamp Kit (Fr. Shaft; Rr.)	UJ530-10
U-Joint (Rr. Shaft; Frt.) ^③	UJ331A
Brute Force Greaseable	UJ232A
Clamp Kit (Rr. Shaft; Frt.)	UJ492-10
U-Joint (Rr. Shaft; Rr.) ^④	UJ331A
Brute Force Greaseable	UJ232A
Clamp Kit (Rr. Shaft; Rr.)	UJ492-10

Drive Shaft (4 W/D) (Cont.)

U-Joint (Cont.)

2006 H1: [Type 24]

U-Joint (Fr. Shaft; Frt.) ^①	UJ354
Brute Force Greaseable	UJ270
Brute Force Non Greaseable	UJ254
(For Aluminum Drive Shaft)	UJ354C
U-Joint (Fr. Shaft; Ctr.) ^②	UJ354
Brute Force Greaseable	UJ270
Brute Force Non Greaseable	UJ254
(For Aluminum Drive Shaft)	UJ354C
U-Joint (Fr. Shaft; Rr.) ^③	UJ354
Brute Force Greaseable	UJ270
Brute Force Non Greaseable	UJ254
(For Aluminum Drive Shaft)	UJ354C
U-Joint (Rr. Shaft; Frt.) ^④	UJ331
Brute Force Greaseable	UJ232
Brute Force Non Greaseable	UJ231
(For Aluminum Drive Shaft)	UJ331C
U-Joint (Rr. Shaft; Rr.) ^⑤	UJ331
Brute Force Greaseable	UJ232
Brute Force Non Greaseable	UJ231
(For Aluminum Drive Shaft)	UJ331C

(Continued)

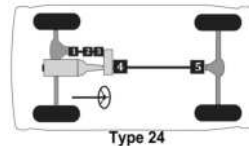
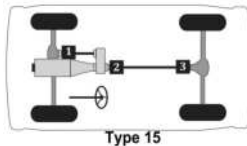
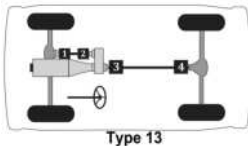

488 ▲ For Use w/ 1.063" Bearing Cap Application. ⊙ For Use w/ 1.188" Bearing Cap Application. ◇ For Use w/ Inner Lock Ring Application on Half Shaft. □ For Use w/ Outer Lock Ring Application on Half Shaft.

Passenger cars, light & medium trucks

(Cont.) -- Hummer H1, H2, H3

MFG./YEAR	MODEL & LOCATION	PART NO.	MFG./YEAR	MODEL & LOCATION	PART NO.
Drive Shaft (4 W/D) (Cont.)			Drive Shaft (4 W/D) (Cont.)		
U-Joint (Cont.)			U-Joint (Cont.)		
			2004-2002 H1: [Type 24]		
	U-Joint (Frnt. Shaft; Frt.) ^①	UJ354		Brute Force Greaseable	UJ270
	Brute Force Non Greaseable	UJ254		(For Aluminum Drive Shaft)	UJ354C
	U-Joint (Frnt. Shaft; Ctr.) ^②	UJ354		Brute Force Greaseable	UJ270
	Brute Force Non Greaseable	UJ254		(For Aluminum Drive Shaft)	UJ354C
	U-Joint (Frnt. Shaft; Rr.) ^③	UJ354		Brute Force Greaseable	UJ270
	Brute Force Non Greaseable	UJ254		(For Aluminum Drive Shaft)	UJ354C
	U-Joint (Rr. Shaft; Frt.) ^④	UJ331		Brute Force Greaseable	UJ232
	Brute Force Non Greaseable	UJ231		(For Aluminum Drive Shaft)	UJ331C
	U-Joint (Rr. Shaft; Rr.) ^⑤	UJ331		Brute Force Greaseable	UJ232
	Brute Force Non Greaseable	UJ231			

IHC Light Truck Scout, Scout II

Drive Shaft (2 W/D)			Drive Shaft (4 W/D)		
U-Joint			U-Joint		
1980-1970 Scout & Scout II: [Type 1]			Drive Shaft (4 W/D) (Cont.)		
	U-Joint (Front) ^①	UJ369	U-Joint (Cont.)		
	Brute Force Greaseable	UJ280	1980-1974 Scout II: [Type 26]		
	Brute Force Non Greaseable	UJ269		U-Joint (Frnt. Shaft; Frt.) ^①	UJ369
	(For Aluminum Drive Shaft)	UJ369C		Brute Force Greaseable	UJ280
	U-Bolt Kit (Front)	UJ329-10		Brute Force Non Greaseable	UJ269
	U-Joint (Rear) ^②	UJ369		(For Aluminum Drive Shaft)	UJ369C
	Brute Force Greaseable	UJ280		U-Bolt Kit (Frnt. Shaft; Frt.)	UJ329-10
	Brute Force Non Greaseable	UJ269		U-Joint (Frnt. Shaft; Rr.) ^②	UJ369
	(For Aluminum Drive Shaft)	UJ369C		Brute Force Greaseable	UJ280
	U-Bolt Kit (Rear)	UJ329-10		Brute Force Non Greaseable	UJ269
	1968-1966 Scout: [Type 1]			(For Aluminum Drive Shaft)	UJ369C
	U-Joint (Front) ^①	UJ429		U-Bolt Kit (Frnt. Shaft; Rr.)	UJ329-10
	Brute Force Greaseable	UJ250		U-Joint (Rr. Shaft; Frt.) ^③	UJ369
	U-Joint (Rear) ^②	UJ429		Brute Force Greaseable	UJ280
	Brute Force Greaseable	UJ250		Brute Force Non Greaseable	UJ269
	1965-1961 Scout: [Type 1]			(For Aluminum Drive Shaft)	UJ369C
	U-Joint (Front) ^①	UJ505		U-Bolt Kit (Rr. Shaft; Frt.)	UJ329-10
	U-Joint (Rear) ^②	UJ505		U-Joint (Rr. Shaft; Rr.) ^④	UJ369
				Brute Force Greaseable	UJ280
				Brute Force Non Greaseable	UJ269
				(For Aluminum Drive Shaft)	UJ369C
				U-Bolt Kit (Rr. Shaft; Rr.)	UJ329-10
				U-Joint (Wheel Joint) ^⑤	[2] UJ371
				Brute Force Greaseable	UJ377
				Brute Force Non Greaseable	UJ371

(Continued)

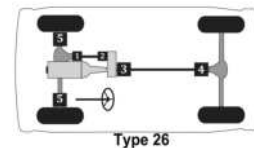
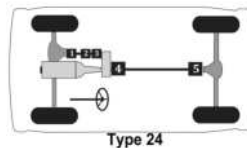
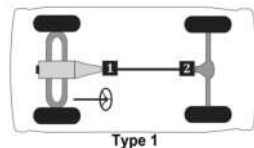

Passenger cars, light & medium trucks

IHC Light Truck Scout, Scout II -- (Cont.)

MFG./YEAR	MODEL & LOCATION	PART NO.	MFG./YEAR	MODEL & LOCATION	PART NO.
Drive Shaft (4 W/D) (Cont.)			Drive Shaft (4 W/D) (Cont.)		
U-Joint (Cont.)			U-Joint (Cont.)		
			1973-1971 Scout II: [Type 26]		
			U-Joint (Frt. Shaft; Frt.) ●		
			Brute Force Greaseable UJ369		
			Brute Force Non Greaseable UJ280		
			(For Aluminum Drive Shaft) UJ269		
			U-Bolt Kit (Frt. Shaft; Frt.) UJ369C		
			U-Joint (Frt. Shaft; Rr.) ⊕		
			Brute Force Greaseable UJ369		
			Brute Force Non Greaseable UJ280		
			(For Aluminum Drive Shaft) UJ269		
			U-Bolt Kit (Frt. Shaft; Rr.) UJ369C		
			U-Joint (Rr. Shaft; Frt.) ⊕		
			Brute Force Greaseable UJ369		
			Brute Force Non Greaseable UJ280		
			(For Aluminum Drive Shaft) UJ269		
			U-Bolt Kit (Rr. Shaft; Frt.) UJ369C		
			U-Joint (Rr. Shaft; Rr.) ⊕		
			Brute Force Greaseable UJ369		
			Brute Force Non Greaseable UJ280		
			(For Aluminum Drive Shaft) UJ269		
			U-Bolt Kit (Rr. Shaft; Rr.) UJ369C		
			U-Joint (Wheel Joint) ⊕		
			[2] UJ365		

IHC Light Truck Metro, 1/2 thru 1 1/2 ton models

Drive Shaft

U-Joint

1972-1968 M1200: [Type 2]

U-Joint (Front) ●	UJ423
U-Joint (Center) ⊕	UJ423
U-Joint (Rear) ⊕	UJ423

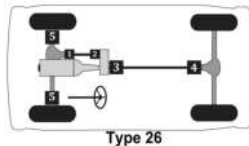
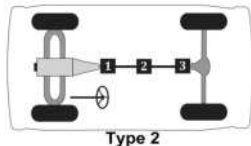

MFG./YEAR	MODEL & LOCATION	PART NO.	MFG./YEAR	MODEL & LOCATION	PART NO.
Drive Shaft (4 W/D)					
U-Joint					
1975-1974 Travelall: [Type 34]					
	U-Joint (Frnt. Shaft; Frt.) ①	UJ369			
	<i>Brute Force Greaseable</i>	UJ280			
	<i>Brute Force Non Greaseable</i>	UJ269			
	(For Aluminum Drive Shaft)	UJ369C			
	U-Joint (Frnt. Shaft; Rr.) ②	UJ369			
	<i>Brute Force Greaseable</i>	UJ280			
	<i>Brute Force Non Greaseable</i>	UJ269			
	(For Aluminum Drive Shaft)	UJ369C			
	U-Joint (Intmd. Shaft; Frt.) ③	UJ369			
	<i>Brute Force Greaseable</i>	UJ280			
	<i>Brute Force Non Greaseable</i>	UJ269			
	(For Aluminum Drive Shaft)	UJ369C			
	U-Joint (Intmd. Shaft; Rr.) ④	UJ369			
	<i>Brute Force Greaseable</i>	UJ280			
	<i>Brute Force Non Greaseable</i>	UJ269			
	(For Aluminum Drive Shaft)	UJ369C			
	U-Joint (Rr. Shaft; Frt.) ⑤	UJ369			
	<i>Brute Force Greaseable</i>	UJ280			
	<i>Brute Force Non Greaseable</i>	UJ269			
	(For Aluminum Drive Shaft)	UJ369C			
	U-Joint (Rr. Shaft; Rr.) ⑥	UJ369			
	<i>Brute Force Greaseable</i>	UJ280			

Infiniti Truck

Drive Shaft (2 W/D)	
U-Joint	
2006-2004 QX56: [Type 2]	
	U-Joint (Front) ①
	<i>Brute Force Greaseable</i>
	<i>Brute Force Non Greaseable</i>
	(For Aluminum Drive Shaft)
	U-Joint (Center) ②
	<i>Brute Force Greaseable</i>
	<i>Brute Force Non Greaseable</i>
	(For Aluminum Drive Shaft)
	U-Joint (Rear) ③
	<i>Brute Force Greaseable</i>
	<i>Brute Force Non Greaseable</i>
	(For Aluminum Drive Shaft)
	2003-2001 QX4: [Type 1]
	U-Joint (Front) ①
	U-Joint (Rear) ②

Drive Shaft (4 W/D)	
U-Joint	
2006-2004 QX56: [Type 13]	
	U-Joint (Frnt. Shaft; Frt.) ①
	<i>Brute Force Greaseable</i>
	<i>Brute Force Non Greaseable</i>
	(For Aluminum Drive Shaft)
	U-Joint (Frnt. Shaft; Rr.) ②
	<i>Brute Force Greaseable</i>
	<i>Brute Force Non Greaseable</i>
	(For Aluminum Drive Shaft)
	U-Joint (Rr. Shaft; Frt.) ③
	<i>Brute Force Greaseable</i>
	<i>Brute Force Non Greaseable</i>
	(For Aluminum Drive Shaft)
	2003-1997 QX4: [Type 13]
	U-Joint (Frnt. Shaft; Frt.) ①
	U-Joint (Frnt. Shaft; Rr.) ②
	U-Joint (Rr. Shaft; Frt.) ③
	U-Joint (Rr. Shaft; Rr.) ④

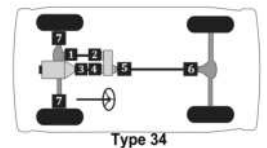
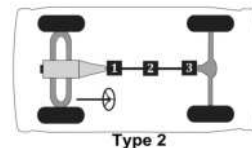
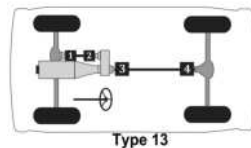
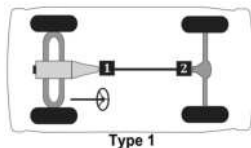

Passenger cars, light & medium trucks

Isuzu Truck Amigo, Ascender, Axiom, Hombre, i-280, i-290, i-350, i-370, Pickup, Rodeo, Rodeo Sport, Trooper, Vehicross

MFG./YEAR	MODEL & LOCATION	PART NO.	MFG./YEAR	MODEL & LOCATION	PART NO.
-----------	------------------	----------	-----------	------------------	----------

Drive Shaft (2 W/D)

U-Joint

2008-2006 i-280, i-290, & i-370 w/ 2 Joint Shaft:

[Type 1]

U-Joint (Front) ⊙	UJ354
Brute Force Greaseable	UJ270
Brute Force Non Greaseable	UJ254
(For Aluminum Drive Shaft)	UJ354C
U-Joint (Rear) ⊙	UJ355
Brute Force Greaseable	UJ290
(For Aluminum Drive Shaft)	UJ355C
Clamp Kit (Rear)	UJ530-10

2008-2006 i-280, i-290, & i-370 w/ 3 Joint Shaft:

[Type 2]

U-Joint (Front) ⊙	UJ354
Brute Force Greaseable	UJ270
Brute Force Non Greaseable	UJ254
(For Aluminum Drive Shaft)	UJ354C
U-Joint (Center) ⊙	UJ354
Brute Force Greaseable	UJ270
Brute Force Non Greaseable	UJ254
(For Aluminum Drive Shaft)	UJ354C
Clamp Kit (Center)	UJ437-10
U-Joint (Rear) ⊙	UJ355
Brute Force Greaseable	UJ290
(For Aluminum Drive Shaft)	UJ355C
Clamp Kit (Rear)	UJ530-10

2008-2003 Ascender: [Type 1]

U-Joint (Front) ⊙	UJ534G
Brute Force Greaseable	UJ235
Brute Force Non Greaseable	UJ234
Clamp Kit (Front)	UJ530-10
U-Joint (Rear) ⊙	UJ534G
Brute Force Greaseable	UJ235
Brute Force Non Greaseable	UJ234
Clamp Kit (Rear)	UJ530-10

2004-2002 Axiom: [Type 1]

U-Joint (Front) ⊙	UJ369
Brute Force Greaseable	UJ280
Brute Force Non Greaseable	UJ269
(For Aluminum Drive Shaft)	UJ369C
U-Joint (Rear) ⊙	UJ369
Brute Force Greaseable	UJ280
Brute Force Non Greaseable	UJ269
(For Aluminum Drive Shaft)	UJ369C

Drive Shaft (2 W/D) (Cont.)

U-Joint (Cont.)

2004-1998 Rodeo: [Type 1]

U-Joint (Front) ⊙	UJ369
Brute Force Greaseable	UJ280
Brute Force Non Greaseable	UJ269
(For Aluminum Drive Shaft)	UJ369C
Clamp Kit (Front)	UJ437-10
U-Joint (Rear) ⊙	UJ369
Brute Force Greaseable	UJ280
Brute Force Non Greaseable	UJ269
(For Aluminum Drive Shaft)	UJ369C
Clamp Kit (Rear)	UJ437-10

2003-2001 Rodeo Sport: [Type 1]

U-Joint (Front) ⊙	UJ369
Brute Force Greaseable	UJ280
Brute Force Non Greaseable	UJ269
(For Aluminum Drive Shaft)	UJ369C
Clamp Kit (Front)	UJ437-10
U-Joint (Rear) ⊙	UJ369
Brute Force Greaseable	UJ280
Brute Force Non Greaseable	UJ269
(For Aluminum Drive Shaft)	UJ369C
Clamp Kit (Rear)	UJ437-10

2002-2000 Trooper: [Type 2]

U-Joint (Front) ⊙	UJ411
U-Joint (Center) ⊙	UJ411
U-Joint (Rear) ⊙	UJ411

2000-1998 Amigo: [Type 1]

U-Joint (Front) ⊙	UJ369
Brute Force Greaseable	UJ280
Brute Force Non Greaseable	UJ269
(For Aluminum Drive Shaft)	UJ369C
U-Joint (Rear) ⊙	UJ369
Brute Force Greaseable	UJ280
Brute Force Non Greaseable	UJ269
(For Aluminum Drive Shaft)	UJ369C

2000-1996 Hombre w/ Standard Cab: [Type 1]

U-Joint (Front) ⊙	UJ534G
Brute Force Greaseable	UJ235
Brute Force Non Greaseable	UJ234
Clamp Kit (Front)	UJ530-10
U-Joint (Rear) ⊙	UJ534G
Brute Force Greaseable	UJ235
Brute Force Non Greaseable	UJ234
Clamp Kit (Rear)	UJ530-10

(Continued)

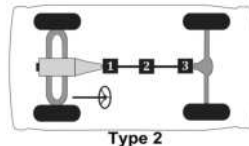
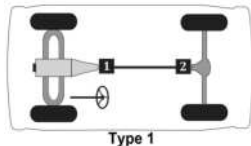

Passenger cars, light & medium trucks

(Cont.) -- Isuzu Truck Amigo, Ascender, Axiom, Hombre, i-280, i-290, i-350, i-370, Pickup, Rodeo, Rodeo Sport, Trooper, Vehicross

MFG./YEAR	MODEL & LOCATION	PART NO.	MFG./YEAR	MODEL & LOCATION	PART NO.
Drive Shaft (2 W/D) (Cont.)			Drive Shaft (2 W/D) (Cont.)		
U-Joint (Cont.)			U-Joint (Cont.)		
2000-1996 Hombre w/ Extended Cab: [Type 2]			1995-1990 Pickup w/ 119.2" WB, U.S. Built from 1/90: [Type 2]		
	U-Joint (Front)⓪	UJ534G		U-Joint (Front)⓪	UJ369
	Brute Force Greaseable	UJ235		Brute Force Greaseable	UJ280
	Brute Force Non Greaseable	UJ234		Brute Force Non Greaseable	UJ269
	Clamp Kit (Front)	UJ530-10		(For Aluminum Drive Shaft)	UJ369C
	U-Joint (Center)⓪	UJ534G		Clamp Kit (Front)	UJ437-10
	Brute Force Greaseable	UJ235		U-Joint (Center)⓪	UJ369
	Brute Force Non Greaseable	UJ234		Brute Force Greaseable	UJ280
	Clamp Kit (Center)	UJ530-10		Brute Force Non Greaseable	UJ269
	U-Joint (Rear)⓪	UJ534G		(For Aluminum Drive Shaft)	UJ369C
	Brute Force Greaseable	UJ235		Clamp Kit (Center)	UJ437-10
	Brute Force Non Greaseable	UJ234		U-Joint (Rear)⓪	UJ369
	Clamp Kit (Rear)	UJ530-10		Brute Force Greaseable	UJ280
1997-1991 Rodeo: [Type 2]				Brute Force Non Greaseable	UJ269
	U-Joint (Front)⓪	UJ369		(For Aluminum Drive Shaft)	UJ369C
	Brute Force Greaseable	UJ280		Clamp Kit (Rear)	UJ437-10
	Brute Force Non Greaseable	UJ269		Clamp Kit (Center)	UJ437-10
	(For Aluminum Drive Shaft)	UJ369C		U-Joint (Rear)⓪	UJ369
	Clamp Kit (Front)	UJ437-10		Brute Force Greaseable	UJ280
	U-Joint (Center)⓪	UJ369		Brute Force Non Greaseable	UJ269
	Brute Force Greaseable	UJ280		(For Aluminum Drive Shaft)	UJ369C
	Brute Force Non Greaseable	UJ269		1995-1990 Pickup w/ 105.6" WB, U.S. Built from 1/90: [Type 1]	
	(For Aluminum Drive Shaft)	UJ369C		U-Joint (Front)⓪	UJ369
	Clamp Kit (Rear)	UJ437-10		Brute Force Greaseable	UJ280
	Clamp Kit (Center)	UJ437-10		Brute Force Non Greaseable	UJ269
	U-Joint (Rear)⓪	UJ369		(For Aluminum Drive Shaft)	UJ369C
	Brute Force Greaseable	UJ280		1995-1990 Pickup w/ 119.2" WB, U.S. Built from 1/90: [Type 2]	
	Brute Force Non Greaseable	UJ269		U-Joint (Front)⓪	UJ369
	(For Aluminum Drive Shaft)	UJ369C		Brute Force Greaseable	UJ280
	Clamp Kit (Rear)	UJ437-10		Brute Force Non Greaseable	UJ269
	Clamp Kit (Center)	UJ437-10		(For Aluminum Drive Shaft)	UJ369C
	U-Joint (Rear)⓪	UJ369		1995-1990 Pickup w/ 105.6" WB, Japan Built from 1/90: [Type 1]	
	Brute Force Greaseable	UJ280		U-Joint (Front)⓪	UJ383
	Brute Force Non Greaseable	UJ269		U-Joint (Rear)⓪	UJ383
	(For Aluminum Drive Shaft)	UJ369C		1995-1990 Pickup w/ 119.2" WB, Japan Built from 1/90: [Type 2]	
	Clamp Kit (Rear)	UJ437-10		U-Joint (Front)⓪	UJ383
	Clamp Kit (Center)	UJ437-10		U-Joint (Center)⓪	UJ383
	U-Joint (Rear)⓪	UJ369		U-Joint (Rear)⓪	UJ383
	Brute Force Greaseable	UJ280		1994-1989 Amigo: [Type 1]	
	Brute Force Non Greaseable	UJ269		U-Joint (Front)⓪	UJ383
	(For Aluminum Drive Shaft)	UJ369C		U-Joint (Rear)⓪	UJ383
	Clamp Kit (Rear)	UJ437-10		1990-1988 Pickup w/ 105.6" WB From 12/87 Thru 12/90: [Type 1]	
	Clamp Kit (Center)	UJ437-10		U-Joint (Front)⓪	UJ383
	U-Joint (Rear)⓪	UJ369		U-Joint (Rear)⓪	UJ383
	Brute Force Greaseable	UJ280		1990-1988 Pickup w/ 119.2" WB From 12/87 Thru 12/90: [Type 2]	
	Brute Force Non Greaseable	UJ269		U-Joint (Front)⓪	UJ383
	(For Aluminum Drive Shaft)	UJ369C		U-Joint (Center)⓪	UJ383
	Clamp Kit (Rear)	UJ437-10		U-Joint (Rear)⓪	UJ383
	Clamp Kit (Center)	UJ437-10		1988-1986 2.0L & 2.2L Gas Eng. w/ 104.3" WB Thru 11/87: [Type 1]	
	U-Joint (Rear)⓪	UJ369		U-Joint (Front)⓪	UJ341
	Brute Force Greaseable	UJ280		U-Joint (Rear)⓪	UJ341
	Brute Force Non Greaseable	UJ269		1988-1986 2.0L & 2.2L Gas Eng. w/ 117.9" WB Thru 11/87: [Type 2]	
	(For Aluminum Drive Shaft)	UJ369C		U-Joint (Front)⓪	UJ341
	Clamp Kit (Rear)	UJ437-10		U-Joint (Center)⓪	UJ341
				U-Joint (Rear)⓪	UJ341
				1988-1986 2.2L Diesel & 2.3L Gas Eng. w/ 104.3 WB Thru 11/87: [Type 1]	
				U-Joint (Front)⓪	UJ341
				U-Joint (Rear)⓪	UJ383

(Continued)

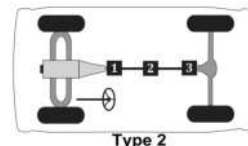
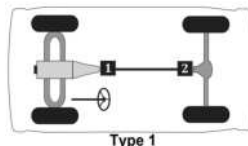

Passenger cars, light & medium trucks

Isuzu Truck Amigo, Ascender, Axiom, Hombre, i-280, i-290, i-350, i-370, Pickup, Rodeo, Rodeo Sport, Trooper, Vehicross -- (Cont.)

MFG./YEAR	MODEL & LOCATION	PART NO.	MFG./YEAR	MODEL & LOCATION	PART NO.
Drive Shaft (2 W/D) (Cont.)			Drive Shaft (4 W/D) (Cont.)		
U-Joint (Cont.)			U-Joint (Cont.)		
1988-1986 2.2L Diesel & 2.3L Gas Eng. w/ 117.9 WB Thru 11/87: [Type 2]			2004-1998 Rodeo & Rodeo Sport: [Type 13]		
	U-Joint (Front)⓪	UJ341		U-Joint (Fr. Shaft; Frt.)⓪	UJ369
	U-Joint (Center)⓪	UJ341		Brute Force Greaseable	UJ280
	U-Joint (Rear)⓪	UJ383		Brute Force Non Greaseable	UJ269
1985-1981 Pickup w/ 104.3" WB: [Type 1]				(For Aluminum Drive Shaft)	UJ369C
	U-Joint (Front)⓪	UJ341		U-Joint (Fr. Shaft; Rr.)⓪	UJ369
	U-Joint (Rear)⓪	UJ341		Brute Force Greaseable	UJ280
1985-1981 Pickup w/ 117.9" WB: [Type 2]				Brute Force Non Greaseable	UJ269
	U-Joint (Front)⓪	UJ341		(For Aluminum Drive Shaft)	UJ369C
	U-Joint (Center)⓪	UJ341		U-Joint (Rr. Shaft; Frt.)⓪	UJ369
	U-Joint (Rear)⓪	UJ341		Brute Force Greaseable	UJ280
Drive Shaft (4 W/D)				Brute Force Non Greaseable	UJ269
U-Joint				(For Aluminum Drive Shaft)	UJ369C
2008-2006 i-350 & i-370: [Type 15]				U-Joint (Rr. Shaft; Rr.)⓪	UJ369
	U-Joint (Fr. Shaft; Frt.)⓪	UJ369		Brute Force Greaseable	UJ280
	Brute Force Greaseable	UJ280		Brute Force Non Greaseable	UJ269
	Brute Force Non Greaseable	UJ269		(For Aluminum Drive Shaft)	UJ369C
	(For Aluminum Drive Shaft)	UJ369C		U-Joint (Fr. Shaft; Frt.)⓪	UJ369
	Clamp Kit (Fr. Shaft; Frt.)	UJ360-10		Brute Force Greaseable	UJ280
	U-Joint (Rr. Shaft; Frt.)⓪	UJ354		Brute Force Non Greaseable	UJ269
	Brute Force Greaseable	UJ270		(For Aluminum Drive Shaft)	UJ369C
	Brute Force Non Greaseable	UJ254		U-Joint (Fr. Shaft; Rr.)⓪	UJ369
	(For Aluminum Drive Shaft)	UJ354C		Brute Force Greaseable	UJ280
	U-Joint (Rr. Shaft; Rr.)⓪	UJ355		Brute Force Non Greaseable	UJ269
	Brute Force Greaseable	UJ290		(For Aluminum Drive Shaft)	UJ369C
	(For Aluminum Drive Shaft)	UJ355C		U-Joint (Rr. Shaft; Frt.)⓪	UJ369
	Clamp Kit (Rr. Shaft; Rr.)	UJ530-10		Brute Force Greaseable	UJ280
2008-2003 Ascender: [Type 15]				Brute Force Non Greaseable	UJ269
	U-Joint (Fr. Shaft; Frt.)⓪	UJ445		(For Aluminum Drive Shaft)	UJ369C
	Brute Force Greaseable	UJ225		U-Joint (Rr. Shaft; Frt.)⓪	UJ369
	Clamp Kit (Fr. Shaft; Frt.)	UJ360-10		Brute Force Greaseable	UJ280
	U-Joint (Rr. Shaft; Frt.)⓪	UJ534G		Brute Force Non Greaseable	UJ269
	Brute Force Greaseable	UJ235		(For Aluminum Drive Shaft)	UJ369C
	Brute Force Non Greaseable	UJ234		U-Joint (Fr. Shaft; Rr.)⓪	UJ369
	Clamp Kit (Rr. Shaft; Frt.)	UJ530-10		Brute Force Greaseable	UJ280
	U-Joint (Rr. Shaft; Rr.)⓪	UJ534G		Brute Force Non Greaseable	UJ269
	Brute Force Greaseable	UJ235		(For Aluminum Drive Shaft)	UJ369C
	Brute Force Non Greaseable	UJ234		U-Joint (Rr. Shaft; Rr.)⓪	UJ369
	Clamp Kit (Rr. Shaft; Rr.)	UJ530-10		Brute Force Greaseable	UJ280
2004-2002 Axiom: [Type 17]				Brute Force Non Greaseable	UJ269
	U-Joint (Rr. Shaft; Frt.)⓪	UJ369		(For Aluminum Drive Shaft)	UJ369C
	Brute Force Greaseable	UJ280			
	Brute Force Non Greaseable	UJ269			
	(For Aluminum Drive Shaft)	UJ369C			
	U-Joint (Rr. Shaft; Rr.)⓪	UJ369			
	Brute Force Greaseable	UJ280			
	Brute Force Non Greaseable	UJ269			
	(For Aluminum Drive Shaft)	UJ369C			

(Continued)

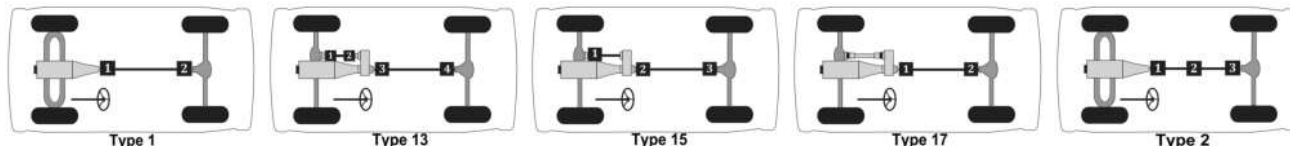

494 ▲ For Use w/ 1.063" Bearing Cap Application. ⓪ For Use w/ 1.188" Bearing Cap Application. ◇ For Use w/ Inner Lock Ring Application on Half Shaft. □ For Use w/ Outer Lock Ring Application on Half Shaft.

Passenger cars, light & medium trucks

(Cont.) -- Isuzu Truck Amigo, Ascender, Axiom, Hombre, i-280, i-290, i-350, i-370, Pickup, Rodeo, Rodeo Sport, Trooper, Vehicross

MFG./YEAR	MODEL & LOCATION	PART NO.	MFG./YEAR	MODEL & LOCATION	PART NO.
Drive Shaft (4 W/D) (Cont.)			Drive Shaft (4 W/D) (Cont.)		
U-Joint (Cont.)			U-Joint (Cont.)		
2000-1998 Hombre: [Type 15]			1995-1990 Pickup American Built From 11/90:		
	U-Joint (Fr. Shaft; Frt.) ^①	UJ445		[Type 14]	
	Brute Force Greaseable	UJ225		U-Joint (Fr. Shaft; Frt.) ^①	UJ383
	Clamp Kit (Fr. Shaft; Frt.)	UJ360-10		U-Joint (Fr. Shaft; Rr.) ^②	UJ383
	U-Joint (Rr. Shaft; Frt.) ^②	UJ534G		U-Joint (Rr. Shaft; Frt.) ^③	UJ369
	Brute Force Greaseable	UJ235		Brute Force Greaseable	UJ280
	Brute Force Non Greaseable	UJ234		Brute Force Non Greaseable	UJ269
	Clamp Kit (Rr. Shaft; Frt.)	UJ530-10		(For Aluminum Drive Shaft)	UJ369C
	U-Joint (Rr. Shaft; Rr.) ^③	UJ534G		Clamp Kit (Rr. Shaft; Frt.)	UJ437-10
	Brute Force Greaseable	UJ235		U-Joint (Rr. Shaft; Ctr.) ^④	UJ369
	Brute Force Non Greaseable	UJ234		Brute Force Greaseable	UJ280
	Clamp Kit (Rr. Shaft; Rr.)	UJ530-10		Brute Force Non Greaseable	UJ269
	1997-1991 Rodeo: [Type 14]			(For Aluminum Drive Shaft)	UJ369C
	U-Joint (Fr. Shaft; Frt.) ^①	UJ383		Clamp Kit (Rr. Shaft; Ctr.)	UJ437-10
	U-Joint (Fr. Shaft; Rr.) ^②	UJ383		U-Joint (Rr. Shaft; Rr.) ^⑤	UJ369
	U-Joint (Rr. Shaft; Frt.) ^③	UJ369		Brute Force Greaseable	UJ280
	Brute Force Greaseable	UJ280		Brute Force Non Greaseable	UJ269
	Brute Force Non Greaseable	UJ269		(For Aluminum Drive Shaft)	UJ369C
	(For Aluminum Drive Shaft)	UJ369C		Clamp Kit (Rr. Shaft; Rr.)	UJ437-10
	U-Joint (Rr. Shaft; Ctr.) ^④	UJ369		1991-1988 Pickup From 12/87 Thru 10/90: [Type 14]	
	Brute Force Greaseable	UJ280		U-Joint (Fr. Shaft; Frt.) ^①	UJ383
	Brute Force Non Greaseable	UJ269		U-Joint (Fr. Shaft; Rr.) ^②	UJ383
	(For Aluminum Drive Shaft)	UJ369C		U-Joint (Rr. Shaft; Frt.) ^③	UJ383
	Clamp Kit (Rr. Shaft; Ctr.)	UJ437-10		U-Joint (Rr. Shaft; Ctr.) ^④	UJ383
	U-Joint (Rr. Shaft; Rr.) ^⑤	UJ369		U-Joint (Rr. Shaft; Rr.) ^⑤	UJ383
	Brute Force Greaseable	UJ280		1988-1986 Pickup Thru 11/87: [Type 14]	
	Brute Force Non Greaseable	UJ269		U-Joint (Fr. Shaft; Frt.) ^①	UJ341
	(For Aluminum Drive Shaft)	UJ369C		U-Joint (Fr. Shaft; Rr.) ^②	UJ383
	1997-1987 Trooper & Trooper II w/ 3 Joint Rr.			U-Joint (Rr. Shaft; Frt.) ^③	UJ341
	Shaft From 11/86: [Type 14]			U-Joint (Rr. Shaft; Ctr.) ^④	UJ341
	U-Joint (Fr. Shaft; Frt.) ^①	UJ383		U-Joint (Rr. Shaft; Rr.) ^⑤	UJ383
	U-Joint (Fr. Shaft; Rr.) ^②	UJ383		1987-1984 Trooper II Thru 6/87: [Type 14]	
	U-Joint (Rr. Shaft; Frt.) ^③	UJ383		U-Joint (Fr. Shaft; Frt.) ^①	UJ341
	U-Joint (Rr. Shaft; Ctr.) ^④	UJ383		U-Joint (Fr. Shaft; Rr.) ^②	UJ383
	U-Joint (Rr. Shaft; Rr.) ^⑤	UJ383		U-Joint (Rr. Shaft; Frt.) ^③	UJ341
	1997-1987 Trooper & Trooper II w/ 2 Joint Rr.			U-Joint (Rr. Shaft; Ctr.) ^④	UJ341
	Shaft From 7/87: [Type 13]			U-Joint (Rr. Shaft; Rr.) ^⑤	UJ341
	U-Joint (Fr. Shaft; Frt.) ^①	UJ383		1985-1981 Pickup: [Type 14]	
	U-Joint (Fr. Shaft; Rr.) ^②	UJ383		U-Joint (Fr. Shaft; Frt.) ^①	UJ341
	U-Joint (Rr. Shaft; Frt.) ^③	UJ383		U-Joint (Fr. Shaft; Rr.) ^②	UJ383
	U-Joint (Rr. Shaft; Rr.) ^⑤	UJ383		U-Joint (Rr. Shaft; Frt.) ^③	UJ341
	1995-1991 Pickup Japan Built From 11/90:			U-Joint (Rr. Shaft; Ctr.) ^④	UJ341
	[Type 14]			U-Joint (Rr. Shaft; Rr.) ^⑤	UJ341
	U-Joint (Fr. Shaft; Frt.) ^①	UJ383			
	U-Joint (Fr. Shaft; Rr.) ^②	UJ383			
	U-Joint (Rr. Shaft; Frt.) ^③	UJ383			
	U-Joint (Rr. Shaft; Ctr.) ^④	UJ383			
	U-Joint (Rr. Shaft; Rr.) ^⑤	UJ383			

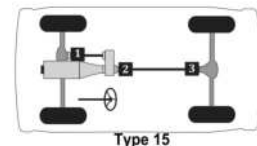
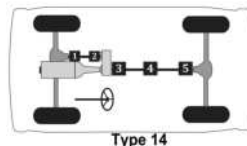
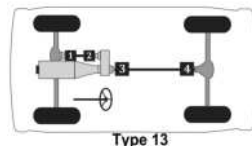

Passenger cars, light & medium trucks

Isuzu Truck EVR, FRR, FSR, FTR, FVR, HTR, HVR, NPR, NQR, NRR

MFG./YEAR MODEL & LOCATION PART NO. MFG./YEAR MODEL & LOCATION PART NO.

Drive Shaft

U-Joint

2004-1996 NPR w/ Diesel Eng. From 3/96: [Type 2]	
U-Joint (Front)Ⓛ	UJ382
U-Joint (Center)Ⓜ	UJ382
U-Joint (Rear)Ⓢ	UJ382
2004-1996 NPR w/ Gasoline Eng. From 3/96: [Type 2]	
U-Joint (Front)Ⓛ	UJ330
Brute Force Greaseable	UJ295
(For Aluminum Drive Shaft)	UJ330C
U-Joint (Center)Ⓜ	UJ330
Brute Force Greaseable	UJ295
(For Aluminum Drive Shaft)	UJ330C
U-Joint (Rear)Ⓢ	UJ330
Brute Force Greaseable	UJ295
(For Aluminum Drive Shaft)	UJ330C
1996-1992 NPR w/ Diesel Eng. & 2 Joint Shaft From 8/92 Thru 2/96: [Type 1]	
U-Joint (Front)Ⓛ	UJ382
U-Joint (Rear)Ⓢ	UJ382
1996-1992 NPR w/ Diesel Eng. & 3 Joint Shaft From 8/92 Thru 2/96: [Type 2]	
U-Joint (Front)Ⓛ	UJ382
U-Joint (Center)Ⓜ	UJ382
U-Joint (Rear)Ⓢ	UJ382
1996-1992 NPR w/ Gas Eng. & 2 Joint Shaft From 8/92 Thru 2/96: [Type 1]	
U-Joint (Front)Ⓛ	UJ330
Brute Force Greaseable	UJ295
(For Aluminum Drive Shaft)	UJ330C
Clamp Kit (Front)	UJ331-10
U-Joint (Rear)Ⓢ	UJ330
Brute Force Greaseable	UJ295
(For Aluminum Drive Shaft)	UJ330C
Clamp Kit (Rear)	UJ331-10

Drive Shaft (Cont.)

U-Joint (Cont.)

1996-1992 NPR w/ Gas Eng. & 3 Joint Shaft From 8/92 Thru 2/96: [Type 2]	
U-Joint (Front)Ⓛ	UJ330
Brute Force Greaseable	UJ295
(For Aluminum Drive Shaft)	UJ330C
Clamp Kit (Front)	UJ331-10
U-Joint (Center)Ⓜ	UJ330
Brute Force Greaseable	UJ295
(For Aluminum Drive Shaft)	UJ330C
Clamp Kit (Center)	UJ331-10
U-Joint (Rear)Ⓢ	UJ330
Brute Force Greaseable	UJ295
(For Aluminum Drive Shaft)	UJ330C
Clamp Kit (Rear)	UJ331-10
1995-1994 NRR & FRR w/ 2 Joint Shaft From 2/94: [Type 1]	
U-Joint (Front)Ⓛ	UJ460
U-Joint (Rear)Ⓢ	UJ460
1995-1994 NRR & FRR w/ 3 Joint Shaft From 2/94: [Type 2]	
U-Joint (Front)Ⓛ	UJ460
U-Joint (Center)Ⓜ	UJ460
U-Joint (Rear)Ⓢ	UJ460
1994-1991 NRR w/ 2 Joint Shaft From 2/91 Thru 1/94: [Type 1]	
U-Joint (Front)Ⓛ	UJ358
Brute Force Non Greaseable	UJ358BF
U-Joint (Rear)Ⓢ	UJ358
Brute Force Non Greaseable	UJ358BF
1994-1991 NRR w/ 3 Joint Shaft From 2/91 Thru 1/94: [Type 2]	
U-Joint (Front)Ⓛ	UJ358
Brute Force Non Greaseable	UJ358BF
U-Joint (Center)Ⓜ	UJ358
Brute Force Non Greaseable	UJ358BF
U-Joint (Rear)Ⓢ	UJ358
Brute Force Non Greaseable	UJ358BF
1992-1986 NPR w/ 2 Joint Shaft Thru 7/92: [Type 1]	
U-Joint (Front)Ⓛ	UJ382
U-Joint (Rear)Ⓢ	UJ382
1992-1986 NPR w/ 3 Joint Shaft Thru 7/92: [Type 2]	
U-Joint (Front)Ⓛ	UJ382
U-Joint (Center)Ⓜ	UJ382
U-Joint (Rear)Ⓢ	UJ382
1991-1988 NRR w/ 2 Joint Shaft From 11/87 Thru 1/91: [Type 1]	
U-Joint (Front)Ⓛ	UJ461
U-Joint (Rear)Ⓢ	UJ461

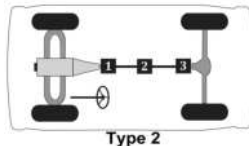
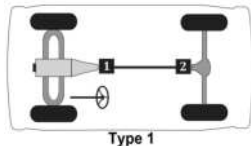

Passenger cars, light & medium trucks

(Cont.) -- Isuzu Truck EVR, FRR, FSR, FTR, FVR, HTR, HVR, NPR, NQR, NRR

MFG./YEAR	MODEL & LOCATION	PART NO.	MFG./YEAR	MODEL & LOCATION	PART NO.
Drive Shaft (Cont.)					
U-Joint (Cont.)					
1991-1988 NRR w/ 3 Joint Shaft From 11/87 Thru					
1/91: [Type 2]					
	U-Joint (Front)Ⓢ	UJ461			
	U-Joint (Center)Ⓢ	UJ461			
	U-Joint (Rear)Ⓢ	UJ461			

Jeep CJ, Commando, Jeepsters VJ, Scrambler, TJ, Wrangler

Drive Shaft (4 W/D)	
U-Joint	
2018-2013 Wrangler: [Type 33]	
U-Joint (Wheel Joint)Ⓢ	[2] UJ20057
2012-2007 Wrangler w/ Trulok Diff.: [Type 33]	
U-Joint (Wheel Joint)Ⓢ	[2] UJ20057
2012-2007 Wrangler w/o Trulok Diff.: [Type 33]	
U-Joint (Wheel Joint)Ⓢ	[4] UJ371
Brute Force Greaseable	UJ377
Brute Force Non Greaseable	UJ371
2006-2005 Wrangler Exc. Rubicon: [Type 26]	
U-Joint (Frnt. Shaft; Frt.)Ⓢ	UJ369
Brute Force Greaseable	UJ280
Brute Force Non Greaseable	UJ269
(For Aluminum Drive Shaft)	UJ369C
Clamp Kit (Frnt. Shaft; Frt.)	UJ437-10
U-Joint (Frnt. Shaft; Rr.)Ⓢ	[2] UJ380
Brute Force Greaseable	UJ280
Brute Force Non Greaseable	UJ269
U-Joint (Rr. Shaft; Frt.)Ⓢ	UJ369
Brute Force Greaseable	UJ280
Brute Force Non Greaseable	UJ269
(For Aluminum Drive Shaft)	UJ369C
Clamp Kit (Rr. Shaft; Frt.)	UJ437-10
U-Joint (Rr. Shaft; Rr.)Ⓢ	UJ369
Brute Force Greaseable	UJ280
Brute Force Non Greaseable	UJ269
(For Aluminum Drive Shaft)	UJ369C
Clamp Kit (Rr. Shaft; Rr.)	UJ437-10
U-Joint (Wheel Joint)Ⓢ	[2] UJ371
Brute Force Greaseable	UJ377
Brute Force Non Greaseable	UJ371
Centering Ball Kit	UJ617
H Yoke	UJ647

Drive Shaft (4 W/D) (Cont.)	
U-Joint (Cont.)	
2006-2005 Wrangler Rubicon: [Type 26]	
U-Joint (Frnt. Shaft; Frt.)Ⓢ	UJ355
Brute Force Greaseable	UJ290
(For Aluminum Drive Shaft)	UJ355C
U-Joint (Frnt. Shaft; Rr.)Ⓢ	[2] UJ354
Brute Force Greaseable	UJ270
Brute Force Non Greaseable	UJ254
(For Aluminum Drive Shaft)	UJ354C
U-Joint (Rr. Shaft; Frt.)Ⓢ	UJ534G
Brute Force Greaseable	UJ235
Brute Force Non Greaseable	UJ234
U-Joint (Rr. Shaft; Rr.)Ⓢ	UJ355
Brute Force Greaseable	UJ290
(For Aluminum Drive Shaft)	UJ355C
Clamp Kit (Rr. Shaft; Rr.)	UJ437-10
U-Joint (Wheel Joint)Ⓢ	[4] UJ371
Brute Force Greaseable	UJ377
Brute Force Non Greaseable	UJ371
Centering Ball Kit	UJ617
H Yoke	UJ648
(Continued)	

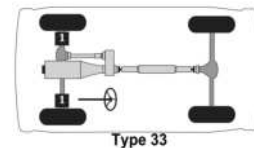
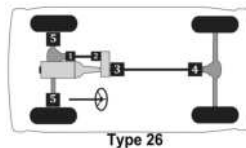
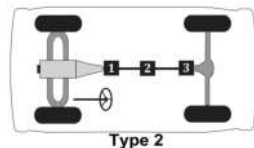

Passenger cars, light & medium trucks

Jeep CJ, Commando, Jeepsters VJ, Scrambler, TJ, Wrangler -- (Cont.)

MFG./YEAR	MODEL & LOCATION	PART NO.	MFG./YEAR	MODEL & LOCATION	PART NO.
Drive Shaft (4 W/D) (Cont.)			Drive Shaft (4 W/D) (Cont.)		
U-Joint (Cont.)			U-Joint (Cont.)		
2006-2005 Wrangler Unlimited Rubicon: [Type 13]			2004-2003 Wrangler Exc. Rubicon: [Type 26]		
	U-Joint (Fr. Shaft; Frt.) ●	UJ355		U-Joint (Fr. Shaft; Frt.) ●	UJ369
	<i>Brute Force Greaseable</i>	UJ290		<i>Brute Force Greaseable</i>	UJ280
	(For Aluminum Drive Shaft)	UJ355C		<i>Brute Force Non Greaseable</i>	UJ269
	U-Joint (Rr. Shaft; Rr.) ⊕	UJ354 [2]		(For Aluminum Drive Shaft)	UJ369C
	<i>Brute Force Greaseable</i>	UJ270		Clamp Kit (Fr. Shaft; Frt.)	UJ437-10
	<i>Brute Force Non Greaseable</i>	UJ254		U-Joint (Fr. Shaft; Rr.) ⊕	UJ380 [2]
	(For Aluminum Drive Shaft)	UJ354C		<i>Brute Force Greaseable</i>	UJ280
	U-Joint (Rr. Shaft; Frt.) ⊕	UJ369		<i>Brute Force Non Greaseable</i>	UJ269
	<i>Brute Force Greaseable</i>	UJ280		(For Aluminum Drive Shaft)	UJ369C
	<i>Brute Force Non Greaseable</i>	UJ269		Clamp Kit (Rr. Shaft; Frt.)	UJ437-10
	(For Aluminum Drive Shaft)	UJ369C		U-Joint (Rr. Shaft; Rr.) ⊕	UJ369
	Clamp Kit (Rr. Shaft; Frt.)	UJ437-10		<i>Brute Force Greaseable</i>	UJ280
	U-Joint (Rr. Shaft; Rr.) ⊕	UJ369		<i>Brute Force Non Greaseable</i>	UJ269
	<i>Brute Force Greaseable</i>	UJ280		(For Aluminum Drive Shaft)	UJ369C
	<i>Brute Force Non Greaseable</i>	UJ269		Clamp Kit (Rr. Shaft; Rr.)	UJ437-10
	(For Aluminum Drive Shaft)	UJ369C		Centering Ball Kit	UJ617
	Clamp Kit (Rr. Shaft; Rr.)	UJ437-10		H Yoke	UJ648
	Centering Ball Kit	UJ617		2006-2005 Wrangler Exc. Rubicon: [Type 26]	
	H Yoke	UJ648		U-Joint (Fr. Shaft; Frt.) ●	UJ369
	2006-2005 Wrangler Exc. Rubicon: [Type 26]			<i>Brute Force Greaseable</i>	UJ280
	U-Joint (Fr. Shaft; Frt.) ●	UJ369		<i>Brute Force Non Greaseable</i>	UJ269
	<i>Brute Force Greaseable</i>	UJ280		(For Aluminum Drive Shaft)	UJ369C
	<i>Brute Force Non Greaseable</i>	UJ269		Clamp Kit (Fr. Shaft; Frt.)	UJ437-10
	(For Aluminum Drive Shaft)	UJ369C		U-Joint (Fr. Shaft; Rr.) ⊕	UJ380 [2]
	Clamp Kit (Fr. Shaft; Frt.)	UJ437-10		<i>Brute Force Greaseable</i>	UJ280
	U-Joint (Fr. Shaft; Rr.) ⊕	UJ380 [2]		<i>Brute Force Non Greaseable</i>	UJ269
	<i>Brute Force Greaseable</i>	UJ280		(For Aluminum Drive Shaft)	UJ369C
	<i>Brute Force Non Greaseable</i>	UJ269		Clamp Kit (Rr. Shaft; Frt.)	UJ437-10
	(For Aluminum Drive Shaft)	UJ369C		U-Joint (Rr. Shaft; Rr.) ⊕	UJ369
	Clamp Kit (Rr. Shaft; Frt.)	UJ437-10		<i>Brute Force Greaseable</i>	UJ280
	U-Joint (Rr. Shaft; Rr.) ⊕	UJ369		<i>Brute Force Non Greaseable</i>	UJ269
	<i>Brute Force Greaseable</i>	UJ280		(For Aluminum Drive Shaft)	UJ369C
	<i>Brute Force Non Greaseable</i>	UJ269		Clamp Kit (Rr. Shaft; Rr.)	UJ437-10
	(For Aluminum Drive Shaft)	UJ369C		U-Joint (Wheel Joint) ⊕	UJ371 [2]
	Clamp Kit (Rr. Shaft; Rr.)	UJ437-10		<i>Brute Force Greaseable</i>	UJ377
	U-Joint (Wheel Joint) ⊕	UJ371 [2]		<i>Brute Force Non Greaseable</i>	UJ371
	<i>Brute Force Greaseable</i>	UJ377		Centering Ball Kit	UJ617
	<i>Brute Force Non Greaseable</i>	UJ371		H Yoke	UJ648
	Centering Ball Kit	UJ617			
	H Yoke	UJ648			
					(Continued)

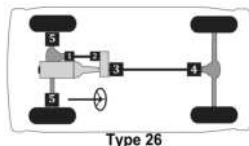
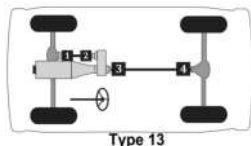

Passenger cars, light & medium trucks

(Cont.) -- Jeep CJ, Commando, Jeepsters VJ, Scrambler, TJ, Wrangler

MFG./YEAR	MODEL & LOCATION	PART NO.	MFG./YEAR	MODEL & LOCATION	PART NO.
Drive Shaft (4 W/D) (Cont.)			Drive Shaft (4 W/D) (Cont.)		
U-Joint (Cont.)			U-Joint (Cont.)		
2002-1999 Wrangler: [Type 26]			1995-1994 Wrangler w/ 4" Rr. Axle Yoke Exc.		
U-Joint (Frnt. Shaft; Frnt.)^①			ABS: [Type 26]		
	<i>Brute Force Greaseable</i>	UJ369		U-Joint (Frnt. Shaft; Frnt.)^①	UJ369
	<i>Brute Force Non Greaseable</i>	UJ280		<i>Brute Force Greaseable</i>	UJ280
	(For Aluminum Drive Shaft)	UJ369C		<i>Brute Force Non Greaseable</i>	UJ269
	Clamp Kit (Frnt. Shaft; Frnt.)	UJ437-10		(For Aluminum Drive Shaft)	UJ369C
	U-Joint (Frnt. Shaft; Rr.)^②	[2] UJ380		Clamp Kit (Frnt. Shaft; Frnt.)	UJ437-10
	<i>Brute Force Greaseable</i>	UJ280		U-Joint (Frnt. Shaft; Rr.)^②	UJ369
	<i>Brute Force Non Greaseable</i>	UJ269		<i>Brute Force Greaseable</i>	UJ280
	U-Joint (Rr. Shaft; Frnt.)^③	UJ369		<i>Brute Force Non Greaseable</i>	UJ269
	<i>Brute Force Greaseable</i>	UJ280		(For Aluminum Drive Shaft)	UJ369C
	<i>Brute Force Non Greaseable</i>	UJ269		Clamp Kit (Frnt. Shaft; Rr.)	UJ437-10
	(For Aluminum Drive Shaft)	UJ369C		U-Joint (Rr. Shaft; Frnt.)^③	UJ369
	Clamp Kit (Rr. Shaft; Frnt.)	UJ437-10		<i>Brute Force Greaseable</i>	UJ280
	U-Joint (Rr. Shaft; Rr.)^④	UJ369		<i>Brute Force Non Greaseable</i>	UJ269
	<i>Brute Force Greaseable</i>	UJ280		(For Aluminum Drive Shaft)	UJ369C
	<i>Brute Force Non Greaseable</i>	UJ269		Clamp Kit (Rr. Shaft; Frnt.)	UJ437-10
	(For Aluminum Drive Shaft)	UJ369C		U-Joint (Rr. Shaft; Rr.)^④	UJ354
	Clamp Kit (Rr. Shaft; Rr.)	UJ437-10		<i>Brute Force Greaseable</i>	UJ270
	U-Joint (Wheel Joint)^⑤	[4] UJ371		<i>Brute Force Non Greaseable</i>	UJ254
	<i>Brute Force Greaseable</i>	UJ377		(For Aluminum Drive Shaft)	UJ354C
	<i>Brute Force Non Greaseable</i>	UJ371		U-Joint (Wheel Joint)^⑤	[2] UJ365
	Centering Ball Kit	UJ617		<i>Brute Force Greaseable</i>	UJ378
	H Yoke	UJ647		<i>Brute Force Non Greaseable</i>	UJ365
1998-1997 Wrangler: [Type 26]			1995-1994 Wrangler w/ 3.5" Rr. Axle Yoke Exc.		
U-Joint (Frnt. Shaft; Frnt.)^①			ABS: [Type 26]		
	<i>Brute Force Greaseable</i>	UJ369		U-Joint (Frnt. Shaft; Frnt.)^①	UJ369
	<i>Brute Force Non Greaseable</i>	UJ280		<i>Brute Force Greaseable</i>	UJ280
	(For Aluminum Drive Shaft)	UJ369C		<i>Brute Force Non Greaseable</i>	UJ269
	Clamp Kit (Frnt. Shaft; Frnt.)	UJ437-10		(For Aluminum Drive Shaft)	UJ369C
	U-Joint (Frnt. Shaft; Rr.)^②	UJ369		Clamp Kit (Frnt. Shaft; Frnt.)	UJ437-10
	<i>Brute Force Greaseable</i>	UJ280		U-Joint (Frnt. Shaft; Rr.)^②	UJ369
	<i>Brute Force Non Greaseable</i>	UJ269		<i>Brute Force Greaseable</i>	UJ280
	(For Aluminum Drive Shaft)	UJ369C		<i>Brute Force Non Greaseable</i>	UJ269
	Clamp Kit (Frnt. Shaft; Rr.)	UJ437-10		(For Aluminum Drive Shaft)	UJ369C
	U-Joint (Rr. Shaft; Frnt.)^③	UJ369		Clamp Kit (Frnt. Shaft; Rr.)	UJ437-10
	<i>Brute Force Greaseable</i>	UJ280		U-Joint (Rr. Shaft; Frnt.)^③	UJ369
	<i>Brute Force Non Greaseable</i>	UJ269		<i>Brute Force Greaseable</i>	UJ280
	(For Aluminum Drive Shaft)	UJ369C		<i>Brute Force Non Greaseable</i>	UJ269
	Clamp Kit (Rr. Shaft; Frnt.)	UJ437-10		(For Aluminum Drive Shaft)	UJ369C
	U-Joint (Rr. Shaft; Rr.)^④	UJ369		Clamp Kit (Rr. Shaft; Frnt.)	UJ437-10
	<i>Brute Force Greaseable</i>	UJ280		U-Joint (Rr. Shaft; Rr.)^④	UJ369
	<i>Brute Force Non Greaseable</i>	UJ269		<i>Brute Force Greaseable</i>	UJ280
	(For Aluminum Drive Shaft)	UJ369C		<i>Brute Force Non Greaseable</i>	UJ269
	Clamp Kit (Rr. Shaft; Rr.)	UJ437-10		(For Aluminum Drive Shaft)	UJ369C
	U-Joint (Wheel Joint)^⑤	[2] UJ371		Clamp Kit (Rr. Shaft; Rr.)	UJ437-10
	<i>Brute Force Greaseable</i>	UJ377		U-Joint (Wheel Joint)^⑤	[2] UJ365
	<i>Brute Force Non Greaseable</i>	UJ371		<i>Brute Force Greaseable</i>	UJ378
				<i>Brute Force Non Greaseable</i>	UJ365

(Continued)

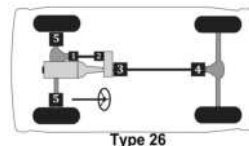

Passenger cars, light & medium trucks

Jeep CJ, Commando, Jeepsters VJ, Scrambler, TJ, Wrangler -- (Cont.)

MFG./YEAR	MODEL & LOCATION	PART NO.	MFG./YEAR	MODEL & LOCATION	PART NO.
Drive Shaft (4 W/D) (Cont.)			Drive Shaft (4 W/D) (Cont.)		
U-Joint (Cont.)			U-Joint (Cont.)		
1995-1994 Wrangler w/ ABS & 4" Rr. Axle Yoke:			1993-1987 Wrangler: [Type 26]		
	[Type 26]				
	U-Joint (Fr. Shaft; Frt.) ⊙	UJ369		U-Joint (Fr. Shaft; Frt.) ⊙	UJ369
	<i>Brute Force Greaseable</i>	UJ280		<i>Brute Force Greaseable</i>	UJ280
	<i>Brute Force Non Greaseable</i>	UJ269		<i>Brute Force Non Greaseable</i>	UJ269
	(For Aluminum Drive Shaft)	UJ369C		(For Aluminum Drive Shaft)	UJ369C
	Clamp Kit (Fr. Shaft; Frt.)	UJ437-10		Clamp Kit (Fr. Shaft; Frt.)	UJ437-10
	U-Joint (Fr. Shaft; Rr.) ⊙	UJ369		U-Joint (Fr. Shaft; Rr.) ⊙	UJ369
	<i>Brute Force Greaseable</i>	UJ280		<i>Brute Force Greaseable</i>	UJ280
	<i>Brute Force Non Greaseable</i>	UJ269		<i>Brute Force Non Greaseable</i>	UJ269
	(For Aluminum Drive Shaft)	UJ369C		(For Aluminum Drive Shaft)	UJ369C
	Clamp Kit (Fr. Shaft; Rr.)	UJ437-10		Clamp Kit (Fr. Shaft; Rr.)	UJ437-10
	U-Joint (Rr. Shaft; Frt.) ⊙	UJ369		U-Joint (Rr. Shaft; Frt.) ⊙	UJ369
	<i>Brute Force Greaseable</i>	UJ280		<i>Brute Force Greaseable</i>	UJ280
	<i>Brute Force Non Greaseable</i>	UJ269		<i>Brute Force Non Greaseable</i>	UJ269
	(For Aluminum Drive Shaft)	UJ369C		(For Aluminum Drive Shaft)	UJ369C
	Clamp Kit (Rr. Shaft; Frt.)	UJ437-10		Clamp Kit (Rr. Shaft; Frt.)	UJ437-10
	U-Joint (Rr. Shaft; Rr.) ⊙	UJ354		U-Joint (Rr. Shaft; Rr.) ⊙	UJ369
	<i>Brute Force Greaseable</i>	UJ270		<i>Brute Force Greaseable</i>	UJ280
	<i>Brute Force Non Greaseable</i>	UJ254		<i>Brute Force Non Greaseable</i>	UJ269
	(For Aluminum Drive Shaft)	UJ354C		(For Aluminum Drive Shaft)	UJ369C
	U-Joint (Wheel Joint) ⊙	[2] UJ371		U-Joint (Wheel Joint) ⊙	[2] UJ365
	<i>Brute Force Greaseable</i>	UJ377		<i>Brute Force Greaseable</i>	UJ378
	<i>Brute Force Non Greaseable</i>	UJ371		<i>Brute Force Non Greaseable</i>	UJ365
	1995-1994 Wrangler w/ ABS & 3.5" Rr. Axle Yoke:		1986-1982 CJ7 & Scrambler: [Type 26]		
	[Type 26]				
	U-Joint (Fr. Shaft; Frt.) ⊙	UJ369		U-Joint (Fr. Shaft; Frt.) ⊙	UJ369
	<i>Brute Force Greaseable</i>	UJ280		<i>Brute Force Greaseable</i>	UJ280
	<i>Brute Force Non Greaseable</i>	UJ269		<i>Brute Force Non Greaseable</i>	UJ269
	(For Aluminum Drive Shaft)	UJ369C		(For Aluminum Drive Shaft)	UJ369C
	Clamp Kit (Fr. Shaft; Frt.)	UJ437-10		U-Joint (Fr. Shaft; Rr.) ⊙	UJ369
	U-Joint (Fr. Shaft; Rr.) ⊙	UJ369		<i>Brute Force Greaseable</i>	UJ280
	<i>Brute Force Greaseable</i>	UJ280		<i>Brute Force Non Greaseable</i>	UJ269
	<i>Brute Force Non Greaseable</i>	UJ269		(For Aluminum Drive Shaft)	UJ369C
	(For Aluminum Drive Shaft)	UJ369C		U-Joint (Rr. Shaft; Frt.) ⊙	UJ369
	Clamp Kit (Fr. Shaft; Rr.)	UJ437-10		<i>Brute Force Greaseable</i>	UJ280
	U-Joint (Rr. Shaft; Frt.) ⊙	UJ369		<i>Brute Force Non Greaseable</i>	UJ269
	<i>Brute Force Greaseable</i>	UJ280		(For Aluminum Drive Shaft)	UJ369C
	<i>Brute Force Non Greaseable</i>	UJ269		U-Joint (Rr. Shaft; Rr.) ⊙	UJ369
	(For Aluminum Drive Shaft)	UJ369C		<i>Brute Force Greaseable</i>	UJ280
	Clamp Kit (Rr. Shaft; Frt.)	UJ437-10		<i>Brute Force Non Greaseable</i>	UJ269
	U-Joint (Rr. Shaft; Rr.) ⊙	UJ369		(For Aluminum Drive Shaft)	UJ369C
	<i>Brute Force Greaseable</i>	UJ280		U-Joint (Wheel Joint) ⊙	[2] UJ365
	<i>Brute Force Non Greaseable</i>	UJ269		<i>Brute Force Greaseable</i>	UJ378
	(For Aluminum Drive Shaft)	UJ369C		<i>Brute Force Non Greaseable</i>	UJ365
	Clamp Kit (Rr. Shaft; Rr.)	UJ437-10			(Continued)
	U-Joint (Wheel Joint) ⊙	[2] UJ371			
	<i>Brute Force Greaseable</i>	UJ377			
	<i>Brute Force Non Greaseable</i>	UJ371			

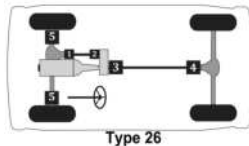

Passenger cars, light & medium trucks

(Cont.) -- Jeep CJ, Commando, Jeepsters VJ, Scrambler, TJ, Wrangler

MFG./YEAR	MODEL & LOCATION	PART NO.	MFG./YEAR	MODEL & LOCATION	PART NO.
Drive Shaft (4 W/D) (Cont.)			Drive Shaft (4 W/D) (Cont.)		
U-Joint (Cont.)			U-Joint (Cont.)		
1983-1982 CJ5:			1981-1980 CJ Series & Scrambler w/ 2 Joint Frt.		
U-Joint (Frt. Shaft; Frt.)UJ369			Shaft: [Type 26]		
<i>Brute Force Greaseable</i>UJ280			U-Joint (Frt. Shaft; Frt.) ①UJ369		
<i>Brute Force Non Greaseable</i>UJ269			<i>Brute Force Greaseable</i>UJ280		
(For Aluminum Drive Shaft)UJ369C			<i>Brute Force Non Greaseable</i>UJ269		
U-Joint (Frt. Shaft; Rr.)UJ369			(For Aluminum Drive Shaft)UJ369C		
<i>Brute Force Greaseable</i>UJ280			U-Joint (Frt. Shaft; Rr.) ②UJ369		
<i>Brute Force Non Greaseable</i>UJ269			<i>Brute Force Greaseable</i>UJ280		
(For Aluminum Drive Shaft)UJ369C			<i>Brute Force Non Greaseable</i>UJ269		
U-Joint (Rr. Shaft; Frt.)UJ369			(For Aluminum Drive Shaft)UJ369C		
<i>Brute Force Greaseable</i>UJ280			U-Joint (Rr. Shaft; Frt.) ③UJ369		
<i>Brute Force Non Greaseable</i>UJ269			<i>Brute Force Greaseable</i>UJ280		
(For Aluminum Drive Shaft)UJ369C			<i>Brute Force Non Greaseable</i>UJ269		
U-Joint (Rr. Shaft; Rr.)UJ369			(For Aluminum Drive Shaft)UJ369C		
<i>Brute Force Greaseable</i>UJ280			U-Joint (Rr. Shaft; Rr.) ④UJ369		
<i>Brute Force Non Greaseable</i>UJ269			<i>Brute Force Greaseable</i>UJ280		
(For Aluminum Drive Shaft)UJ369C			<i>Brute Force Non Greaseable</i>UJ269		
U-Joint (Wheel Joint) [2] UJ365			U-Joint (Wheel Joint) ⑤ [2] UJ365		
<i>Brute Force Greaseable</i>UJ378			<i>Brute Force Greaseable</i>UJ378		
<i>Brute Force Non Greaseable</i>UJ365			<i>Brute Force Non Greaseable</i>UJ365		
1981-1980 CJ Series & Scrambler w/ 3 Joint Frt.			<i>H Yoke</i>UJ647		
Shaft: [Type 26]			1979-1974 CJ Series & Scrambler w/ 2 Joint Frt.		
U-Joint (Frt. Shaft; Frt.) ①UJ369			Shaft: [Type 26]		
<i>Brute Force Greaseable</i>UJ280			U-Joint (Frt. Shaft; Frt.) ①UJ369		
<i>Brute Force Non Greaseable</i>UJ269			<i>Brute Force Greaseable</i>UJ280		
(For Aluminum Drive Shaft)UJ369C			<i>Brute Force Non Greaseable</i>UJ269		
U-Joint (Frt. Shaft; Rr.) ② [2] UJ380			(For Aluminum Drive Shaft)UJ369C		
<i>Brute Force Greaseable</i>UJ280			U-Bolt Kit (Frt. Shaft; Frt.)UJ329-10		
<i>Brute Force Non Greaseable</i>UJ269			U-Joint (Frt. Shaft; Rr.) ②UJ369		
U-Joint (Rr. Shaft; Frt.) ③UJ369			<i>Brute Force Greaseable</i>UJ280		
<i>Brute Force Greaseable</i>UJ280			<i>Brute Force Non Greaseable</i>UJ269		
<i>Brute Force Non Greaseable</i>UJ269			(For Aluminum Drive Shaft)UJ369C		
(For Aluminum Drive Shaft)UJ369C			U-Bolt Kit (Frt. Shaft; Rr.)UJ329-10		
U-Joint (Rr. Shaft; Rr.) ④UJ369			U-Joint (Rr. Shaft; Frt.) ③UJ369		
<i>Brute Force Greaseable</i>UJ280			<i>Brute Force Greaseable</i>UJ280		
<i>Brute Force Non Greaseable</i>UJ269			<i>Brute Force Non Greaseable</i>UJ269		
(For Aluminum Drive Shaft)UJ369C			(For Aluminum Drive Shaft)UJ369C		
U-Joint (Rr. Shaft; Rr.) ④UJ369			U-Bolt Kit (Rr. Shaft; Frt.)UJ329-10		
<i>Brute Force Greaseable</i>UJ280			U-Joint (Rr. Shaft; Rr.) ④UJ369		
<i>Brute Force Non Greaseable</i>UJ269			<i>Brute Force Greaseable</i>UJ280		
(For Aluminum Drive Shaft)UJ369C			<i>Brute Force Non Greaseable</i>UJ269		
U-Joint (Wheel Joint) ⑤ [2] UJ365			(For Aluminum Drive Shaft)UJ369C		
<i>Brute Force Greaseable</i>UJ378			U-Bolt Kit (Rr. Shaft; Rr.)UJ329-10		
<i>Brute Force Non Greaseable</i>UJ365			U-Joint (Wheel Joint) ⑤ [2] UJ365		
Centering YokeUJ607			<i>Brute Force Greaseable</i>UJ378		
<i>H Yoke</i>UJ647			<i>Brute Force Non Greaseable</i>UJ365		
			<i>H Yoke</i>UJ647		
			(Continued)		

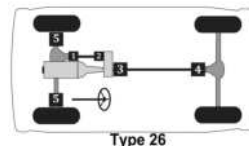

Passenger cars, light & medium trucks

Jeep CJ, Commando, Jeepsters VJ, Scrambler, TJ, Wrangler -- (Cont.)

MFG./YEAR	MODEL & LOCATION	PART NO.	MFG./YEAR	MODEL & LOCATION	PART NO.
Drive Shaft (4 W/D) (Cont.)			Drive Shaft (4 W/D) (Cont.)		
U-Joint (Cont.)			U-Joint (Cont.)		
1979-1974 CJ Series & Scrambler w/ 3 Joint Frt.			1973-1968 CJ Series w/ 2 Grooved & 2 Plain Frt.		
Shaft: [Type 26]			Shaft Brgs. [Type 26]		
U-Joint (Frt. Shaft; Frt.) ^①		UJ369	U-Joint (Frt. Shaft; Frt.) ^①		UJ361
Brute Force Greaseable		UJ280	U-Bolt Kit (Frt. Shaft; Frt.)		UJ329-10
Brute Force Non Greaseable		UJ269	U-Joint (Frt. Shaft; Rr.) ^②		UJ361
(For Aluminum Drive Shaft)		UJ369C	U-Bolt Kit (Frt. Shaft; Rr.)		UJ329-10
U-Bolt Kit (Frt. Shaft; Frt.)		UJ329-10	U-Joint (Rr. Shaft; Frt.) ^③		UJ369
U-Joint (Frt. Shaft; Rr.) ^②	[2]	UJ380	Brute Force Greaseable		UJ280
Brute Force Greaseable		UJ280	Brute Force Non Greaseable		UJ269
Brute Force Non Greaseable		UJ269	(For Aluminum Drive Shaft)		UJ369C
U-Joint (Rr. Shaft; Frt.) ^③		UJ369	U-Bolt Kit (Rr. Shaft; Frt.)		UJ329-10
Brute Force Greaseable		UJ280	U-Joint (Rr. Shaft; Rr.) ^④		UJ369
Brute Force Non Greaseable		UJ269	Brute Force Greaseable		UJ280
(For Aluminum Drive Shaft)		UJ369C	Brute Force Non Greaseable		UJ269
U-Bolt Kit (Rr. Shaft; Frt.)		UJ329-10	(For Aluminum Drive Shaft)		UJ369C
U-Joint (Rr. Shaft; Rr.) ^④		UJ369	U-Bolt Kit (Rr. Shaft; Rr.)		UJ329-10
Brute Force Greaseable		UJ280	U-Joint (Wheel Joint) ^⑤	[2]	UJ365
Brute Force Non Greaseable		UJ269	Brute Force Greaseable		UJ378
(For Aluminum Drive Shaft)		UJ369C	Brute Force Non Greaseable		UJ365
U-Bolt Kit (Rr. Shaft; Rr.)		UJ329-10	1973-1968 CJ Series w/ 4 Plain Frt. Shaft Brgs.:		
U-Joint (Wheel Joint) ^⑤	[2]	UJ365	[Type 26]		
Brute Force Greaseable		UJ378	U-Joint (Frt. Shaft; Frt.) ^①		UJ369
Brute Force Non Greaseable		UJ365	Brute Force Greaseable		UJ280
Centering Yoke		UJ607	Brute Force Non Greaseable		UJ269
H Yoke		UJ647	(For Aluminum Drive Shaft)		UJ369C
1973-1972 Jeepster & Commando: [Type 26]			U-Bolt Kit (Frt. Shaft; Frt.)		UJ329-10
U-Joint (Frt. Shaft; Frt.) ^①		UJ369	U-Joint (Frt. Shaft; Rr.) ^②		UJ369
Brute Force Greaseable		UJ280	Brute Force Greaseable		UJ280
Brute Force Non Greaseable		UJ269	Brute Force Non Greaseable		UJ269
(For Aluminum Drive Shaft)		UJ369C	(For Aluminum Drive Shaft)		UJ369C
U-Bolt Kit (Frt. Shaft; Frt.)		UJ329-10	U-Bolt Kit (Frt. Shaft; Rr.)		UJ329-10
U-Joint (Frt. Shaft; Rr.) ^②		UJ369	U-Joint (Rr. Shaft; Frt.) ^③		UJ369
Brute Force Greaseable		UJ280	Brute Force Greaseable		UJ280
Brute Force Non Greaseable		UJ269	Brute Force Non Greaseable		UJ269
(For Aluminum Drive Shaft)		UJ369C	(For Aluminum Drive Shaft)		UJ369C
U-Bolt Kit (Frt. Shaft; Rr.)		UJ329-10	U-Bolt Kit (Rr. Shaft; Frt.)		UJ329-10
U-Joint (Rr. Shaft; Frt.) ^③		UJ369	U-Joint (Rr. Shaft; Rr.) ^④		UJ369
Brute Force Greaseable		UJ280	Brute Force Greaseable		UJ280
Brute Force Non Greaseable		UJ269	Brute Force Non Greaseable		UJ269
(For Aluminum Drive Shaft)		UJ369C	(For Aluminum Drive Shaft)		UJ369C
U-Bolt Kit (Rr. Shaft; Frt.)		UJ329-10	U-Bolt Kit (Rr. Shaft; Rr.)		UJ329-10
U-Joint (Rr. Shaft; Rr.) ^④		UJ369	U-Joint (Wheel Joint) ^⑤	[2]	UJ365
Brute Force Greaseable		UJ280	Brute Force Greaseable		UJ378
Brute Force Non Greaseable		UJ269	Brute Force Non Greaseable		UJ365
(For Aluminum Drive Shaft)		UJ369C	(Continued)		
U-Bolt Kit (Rr. Shaft; Rr.)		UJ329-10			
U-Joint (Wheel Joint) ^⑤	[2]	UJ365			
Brute Force Greaseable		UJ378			
Brute Force Non Greaseable		UJ365			

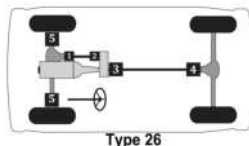

502 ▲ For Use w/ 1.063" Bearing Cap Application. Ⓞ For Use w/ 1.188" Bearing Cap Application. ◇ For Use w/ Inner Lock Ring Application on Half Shaft. □ For Use w/ Outer Lock Ring Application on Half Shaft.

Passenger cars, light & medium trucks

(Cont.) -- Jeep CJ, Commando, Jeepsters VJ, Scrambler, TJ, Wrangler

MFG./YEAR	MODEL & LOCATION	PART NO.	MFG./YEAR	MODEL & LOCATION	PART NO.
Drive Shaft (4 W/D) (Cont.)			Drive Shaft (4 W/D) (Cont.)		
U-Joint (Cont.)			U-Joint (Cont.)		
1971-1967 Jeepster & Commando w/ 4 Cyl. Eng.:			1967-1960 CJ Series w/ Outer Lock Rings:		
[Type 26]			[Type 26]		
U-Joint (Frnt. Shaft; Frt.) ^①		UJ361	U-Joint (Frnt. Shaft; Frt.) ^①		UJ369
U-Bolt Kit (Frnt. Shaft; Frt.)		UJ329-10	Brute Force Greaseable		UJ280
U-Joint (Frnt. Shaft; Rr.) ^②		UJ361	Brute Force Non Greaseable		UJ269
U-Bolt Kit (Frnt. Shaft; Rr.)		UJ329-10	(For Aluminum Drive Shaft)		UJ369C
U-Joint (Rr. Shaft; Frt.) ^③		UJ369	U-Bolt Kit (Frnt. Shaft; Frt.)		UJ329-10
Brute Force Greaseable		UJ280	U-Joint (Frnt. Shaft; Rr.) ^④		UJ369
Brute Force Non Greaseable		UJ269	Brute Force Greaseable		UJ280
(For Aluminum Drive Shaft)		UJ369C	Brute Force Non Greaseable		UJ269
U-Bolt Kit (Rr. Shaft; Frt.)		UJ329-10	(For Aluminum Drive Shaft)		UJ369C
U-Joint (Rr. Shaft; Rr.) ^⑤		UJ369	U-Bolt Kit (Frnt. Shaft; Rr.)		UJ329-10
Brute Force Greaseable		UJ280	U-Joint (Rr. Shaft; Frt.) ^⑥		UJ369
Brute Force Non Greaseable		UJ269	Brute Force Greaseable		UJ280
(For Aluminum Drive Shaft)		UJ369C	Brute Force Non Greaseable		UJ269
U-Bolt Kit (Rr. Shaft; Rr.)		UJ329-10	(For Aluminum Drive Shaft)		UJ369C
U-Joint (Wheel Joint) ^⑦	[2]	UJ365	U-Bolt Kit (Rr. Shaft; Frt.)		UJ329-10
Brute Force Greaseable		UJ378	U-Joint (Rr. Shaft; Rr.) ^⑧		UJ369
Brute Force Non Greaseable		UJ365	Brute Force Greaseable		UJ280
1971-1967 Jeepster & Commando w/ 6 Cyl. Eng.:			Brute Force Non Greaseable		UJ269
[Type 31]			(For Aluminum Drive Shaft)		UJ369C
U-Joint (Frnt. Shaft; Frt.) ^①		UJ361	U-Bolt Kit (Rr. Shaft; Rr.)		UJ329-10
U-Bolt Kit (Frnt. Shaft; Frt.)		UJ329-10	U-Joint (Wheel Joint) ^⑨	[2]	UJ365
U-Joint (Frnt. Shaft; Ctr.) ^②		UJ514G	Brute Force Greaseable		UJ378
U-Joint (Frnt. Shaft; Rr.) ^③		UJ361	Brute Force Non Greaseable		UJ365
U-Bolt Kit (Frnt. Shaft; Rr.)		UJ329-10	1959 CJ Series: [Type 26]		
U-Joint (Rr. Shaft; Frt.) ^④		UJ369	U-Joint (Frnt. Shaft; Frt.) ^①		UJ369
Brute Force Greaseable		UJ280	Brute Force Greaseable		UJ280
Brute Force Non Greaseable		UJ269	Brute Force Non Greaseable		UJ269
(For Aluminum Drive Shaft)		UJ369C	(For Aluminum Drive Shaft)		UJ369C
U-Bolt Kit (Rr. Shaft; Frt.)		UJ329-10	U-Bolt Kit (Frnt. Shaft; Frt.)		UJ329-10
U-Joint (Rr. Shaft; Rr.) ^⑤		UJ369	U-Joint (Frnt. Shaft; Rr.) ^②		UJ369
Brute Force Greaseable		UJ280	Brute Force Greaseable		UJ280
Brute Force Non Greaseable		UJ269	Brute Force Non Greaseable		UJ269
(For Aluminum Drive Shaft)		UJ369C	(For Aluminum Drive Shaft)		UJ369C
U-Bolt Kit (Rr. Shaft; Rr.)		UJ329-10	U-Bolt Kit (Frnt. Shaft; Rr.)		UJ329-10
U-Joint (Wheel Joint) ^⑥	[2]	UJ365	U-Joint (Rr. Shaft; Frt.) ^③		UJ369
Brute Force Greaseable		UJ378	Brute Force Greaseable		UJ280
Brute Force Non Greaseable		UJ365	Brute Force Non Greaseable		UJ269
			(For Aluminum Drive Shaft)		UJ369C
			U-Bolt Kit (Rr. Shaft; Frt.)		UJ329-10
			U-Joint (Rr. Shaft; Rr.) ^④		UJ369
			Brute Force Greaseable		UJ280
			Brute Force Non Greaseable		UJ269
			(For Aluminum Drive Shaft)		UJ369C
			U-Bolt Kit (Rr. Shaft; Rr.)		UJ329-10
			U-Joint (Wheel Joint) ^⑤	[2]	UJ365
			Brute Force Greaseable		UJ378
			Brute Force Non Greaseable		UJ365

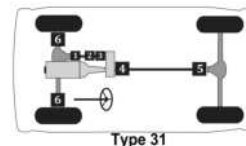
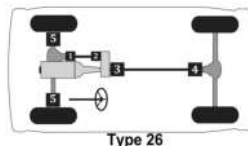

Passenger cars, light & medium trucks

Jeep Cherokee (thru 2001), Comanche, Commander, Grand Cherokee, Liberty, Wagoneer

MFG./YEAR	MODEL & LOCATION	PART NO.	MFG./YEAR	MODEL & LOCATION	PART NO.
Drive Shaft (2 W/D)			Drive Shaft (2 W/D) (Cont.)		
U-Joint			U-Joint (Cont.)		
2007-2004 Commander, Grand Cherokee & Liberty: [Type 1]			2002 Liberty w/ 2.4L Eng.: [Type 1]		
	U-Joint (Front)⊙	UJ369		U-Joint (Front)⊙	UJ369
	Brute Force Greaseable	UJ280		Brute Force Greaseable	UJ280
	Brute Force Non Greaseable	UJ269		Brute Force Non Greaseable	UJ269
	(For Aluminum Drive Shaft)	UJ369C		(For Aluminum Drive Shaft)	UJ369C
	Clamp Kit (Front)	UJ437-10		Clamp Kit (Front)	UJ437-10
	U-Joint (Rear)⊙	UJ369		U-Joint (Rear)⊙	UJ354
	Brute Force Greaseable	UJ280		Brute Force Greaseable	UJ270
	Brute Force Non Greaseable	UJ269		Brute Force Non Greaseable	UJ254
	(For Aluminum Drive Shaft)	UJ369C		(For Aluminum Drive Shaft)	UJ354C
	Clamp Kit (Rear)	UJ437-10		Clamp Kit (Rear)	UJ437-10
2003 Liberty w/ 3.5" Yoke: [Type 1]			2002 Liberty w/ 3.7L Eng. & Auto. Trans.: [Type 1]		
	U-Joint (Front)⊙	UJ369		U-Joint (Front)⊙	UJ354
	Brute Force Greaseable	UJ280		Brute Force Greaseable	UJ270
	Brute Force Non Greaseable	UJ269		Brute Force Non Greaseable	UJ254
	(For Aluminum Drive Shaft)	UJ369C		(For Aluminum Drive Shaft)	UJ354C
	Clamp Kit (Front)	UJ437-10		Clamp Kit (Front)	UJ437-10
	U-Joint (Rear)⊙	UJ369		U-Joint (Rear)⊙	UJ354
	Brute Force Greaseable	UJ280		Brute Force Greaseable	UJ270
	Brute Force Non Greaseable	UJ269		Brute Force Non Greaseable	UJ254
	(For Aluminum Drive Shaft)	UJ369C		(For Aluminum Drive Shaft)	UJ354C
	Clamp Kit (Rear)	UJ437-10		Clamp Kit (Rear)	UJ437-10
2003 Liberty w/ 4" Yoke: [Type 1]			2002 Liberty w/ 3.7L Eng. & Man. Trans.: [Type 1]		
	U-Joint (Front)⊙	UJ354		U-Joint (Front)⊙	UJ354
	Brute Force Greaseable	UJ270		Brute Force Greaseable	UJ270
	Brute Force Non Greaseable	UJ254		Brute Force Non Greaseable	UJ254
	(For Aluminum Drive Shaft)	UJ354C		(For Aluminum Drive Shaft)	UJ354C
	Clamp Kit (Front)	UJ437-10		Clamp Kit (Front)	UJ437-10
	U-Joint (Rear)⊙	UJ354		U-Joint (Rear)⊙	UJ354
	Brute Force Greaseable	UJ270		Brute Force Greaseable	UJ270
	Brute Force Non Greaseable	UJ254		Brute Force Non Greaseable	UJ254
	(For Aluminum Drive Shaft)	UJ354C		(For Aluminum Drive Shaft)	UJ354C
	Clamp Kit (Rear)	UJ437-10		Clamp Kit (Rear)	UJ437-10
2003-2002 Grand Cherokee: [Type 1]			2001-2000 Cherokee & Grand Cherokee w/ 4.0L Eng.: [Type 1]		
	U-Joint (Front)⊙	UJ369		U-Joint (Front)⊙	UJ369
	Brute Force Greaseable	UJ280		Brute Force Greaseable	UJ280
	Brute Force Non Greaseable	UJ269		Brute Force Non Greaseable	UJ269
	(For Aluminum Drive Shaft)	UJ369C		(For Aluminum Drive Shaft)	UJ369C
	Clamp Kit (Front)	UJ437-10		Clamp Kit (Front)	UJ437-10
	U-Joint (Rear)⊙	UJ369		U-Joint (Rear)⊙	UJ369
	Brute Force Greaseable	UJ280		Brute Force Greaseable	UJ280
	Brute Force Non Greaseable	UJ269		Brute Force Non Greaseable	UJ269
	(For Aluminum Drive Shaft)	UJ369C		(For Aluminum Drive Shaft)	UJ369C
	Clamp Kit (Rear)	UJ437-10		Clamp Kit (Rear)	UJ437-10

(Continued)

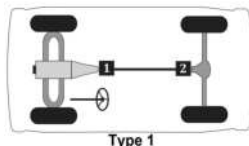

Passenger cars, light & medium trucks

(Cont.) -- Jeep Cherokee (thru 2001), Comanche, Commander, Grand Cherokee, Liberty, Wagoneer

MFG./YEAR	MODEL & LOCATION	PART NO.	MFG./YEAR	MODEL & LOCATION	PART NO.
Drive Shaft (2 W/D) (Cont.)			Drive Shaft (2 W/D) (Cont.)		
U-Joint (Cont.)			U-Joint (Cont.)		
2001-2000 Grand Cherokee w/ 4.7L Eng.: [Type 1]			1969-1966 Wagoneer: [Type 7]		
	U-Joint (Front) ①	UJ354		U-Joint (Rear) ①	UJ315G
	<i>Brute Force Greaseable</i>	UJ270		<i>Brute Force Greaseable</i>	UJ246
	<i>Brute Force Non Greaseable</i>	UJ254		Clamp Kit	UJ318-10
	(For Aluminum Drive Shaft)	UJ354C	1965-1964 Wagoneer w/ Auto. Trans.: [Type 1]		
	U-Joint (Rear) ②	UJ369		U-Joint (Front) ①	UJ507
	<i>Brute Force Greaseable</i>	UJ280		U-Joint (Rear) ②	UJ505
	<i>Brute Force Non Greaseable</i>	UJ269		U-Bolt Kit (Rear)	UJ329-10
	(For Aluminum Drive Shaft)	UJ369C	1965-1964 Wagoneer w/ Man. Trans.: [Type 1]		
	Clamp Kit (Rear)	UJ437-10		U-Joint (Front) ①	UJ369
1999-1985 All: [Type 1]				<i>Brute Force Greaseable</i>	UJ280
	U-Joint (Front) ①	UJ369		<i>Brute Force Non Greaseable</i>	UJ269
	<i>Brute Force Greaseable</i>	UJ280		(For Aluminum Drive Shaft)	UJ369C
	<i>Brute Force Non Greaseable</i>	UJ269		U-Bolt Kit (Front)	UJ329-10
	(For Aluminum Drive Shaft)	UJ369C		U-Joint (Rear) ②	UJ369
	Clamp Kit (Front)	UJ437-10		<i>Brute Force Greaseable</i>	UJ280
	U-Joint (Rear) ②	UJ369		<i>Brute Force Non Greaseable</i>	UJ269
	<i>Brute Force Greaseable</i>	UJ280		(For Aluminum Drive Shaft)	UJ369C
	<i>Brute Force Non Greaseable</i>	UJ269		U-Bolt Kit (Rear)	UJ329-10
	(For Aluminum Drive Shaft)	UJ369C	1963 Wagoneer: [Type 1]		
	Clamp Kit (Rear)	UJ437-10		U-Joint (Front) ①	UJ369
1984-1975 w/ Inner Lock Rings: [Type 1]				<i>Brute Force Greaseable</i>	UJ280
	U-Joint (Front) ①	UJ315G		<i>Brute Force Non Greaseable</i>	UJ269
	<i>Brute Force Greaseable</i>	UJ246		(For Aluminum Drive Shaft)	UJ369C
	Clamp Kit	UJ318-10		U-Bolt Kit (Front)	UJ329-10
	U-Joint (Rear) ②	UJ315G		U-Joint (Rear) ②	UJ369
	<i>Brute Force Greaseable</i>	UJ246		<i>Brute Force Greaseable</i>	UJ280
	Clamp Kit	UJ318-10		<i>Brute Force Non Greaseable</i>	UJ269
	(For Aluminum Drive Shaft)	UJ369C		(For Aluminum Drive Shaft)	UJ369C
1984-1975 w/ Outer Lock Rings: [Type 1]				U-Bolt Kit (Rear)	UJ329-10
	U-Joint (Front) ①	UJ369	Drive Shaft (4 W/D)		
	<i>Brute Force Greaseable</i>	UJ280	U-Joint		
	<i>Brute Force Non Greaseable</i>	UJ269	2007-2005 Liberty w/ Man. Trans.: [Type 17]		
	(For Aluminum Drive Shaft)	UJ369C		U-Joint (Rr. Shaft; Frt.) ①	UJ354
	U-Bolt Kit (Front)	UJ329-10		<i>Brute Force Greaseable</i>	UJ270
	U-Joint (Rear) ②	UJ369		<i>Brute Force Non Greaseable</i>	UJ254
	<i>Brute Force Greaseable</i>	UJ280		(For Aluminum Drive Shaft)	UJ354C
	<i>Brute Force Non Greaseable</i>	UJ269		U-Joint (Rr. Shaft; Rr.) ②	UJ369
	(For Aluminum Drive Shaft)	UJ369C		<i>Brute Force Greaseable</i>	UJ280
	U-Bolt Kit (Rear)	UJ329-10		<i>Brute Force Non Greaseable</i>	UJ269
1974-1970 Wagoneer: [Type 1]				(For Aluminum Drive Shaft)	UJ369C
	U-Joint (Front) ①	UJ369	2007-2005 Liberty w/ Auto. Trans.: [Type 17]		
	<i>Brute Force Greaseable</i>	UJ280		U-Joint (Rr. Shaft; Frt.) ①	UJ369
	<i>Brute Force Non Greaseable</i>	UJ269		<i>Brute Force Greaseable</i>	UJ280
	(For Aluminum Drive Shaft)	UJ369C		<i>Brute Force Non Greaseable</i>	UJ269
	U-Bolt Kit (Front)	UJ329-10		(For Aluminum Drive Shaft)	UJ369C
	U-Joint (Rear) ②	UJ369		U-Joint (Rr. Shaft; Rr.) ②	UJ369
	<i>Brute Force Greaseable</i>	UJ280		<i>Brute Force Greaseable</i>	UJ280
	<i>Brute Force Non Greaseable</i>	UJ269		<i>Brute Force Non Greaseable</i>	UJ269
	(For Aluminum Drive Shaft)	UJ369C		(For Aluminum Drive Shaft)	UJ369C
	U-Bolt Kit (Rear)	UJ329-10	(Continued)		

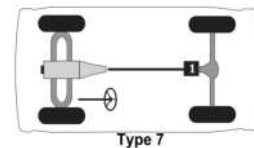
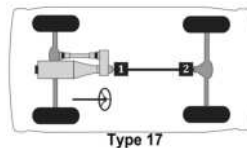
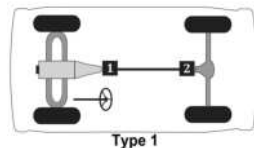

Passenger cars, light & medium trucks

Jeep Cherokee (thru 2001), Comanche, Commander, Grand Cherokee, Liberty, Wagoneer -- (Cont.)

MFG./YEAR	MODEL & LOCATION	PART NO.	MFG./YEAR	MODEL & LOCATION	PART NO.
Drive Shaft (4 W/D) (Cont.)			Drive Shaft (4 W/D) (Cont.)		
U-Joint (Cont.)			U-Joint (Cont.)		
2004	Grand Cherokee w/ 6 Cyl. Eng.:		2003	Liberty w/ 3.5" Yoke: [Type 17]	
	[Type 15]				
	U-Joint (Fr. Shaft; Frt.)⊙	UJ369		U-Joint (Rr. Shaft; Frt.)⊙	UJ369
	Brute Force Greaseable	UJ280		Brute Force Greaseable	UJ280
	Brute Force Non Greaseable	UJ269		Brute Force Non Greaseable	UJ269
	(For Aluminum Drive Shaft)	UJ369C		(For Aluminum Drive Shaft)	UJ369C
	Clamp Kit (Fr. Shaft; Frt.)	UJ437-10		Clamp Kit (Rr. Shaft; Frt.)	UJ437-10
	U-Joint (Rr. Shaft; Rr.)⊙	UJ369		U-Joint (Rr. Shaft; Rr.)⊙	UJ369
	Brute Force Greaseable	UJ280		Brute Force Greaseable	UJ280
	Brute Force Non Greaseable	UJ269		Brute Force Non Greaseable	UJ269
	(For Aluminum Drive Shaft)	UJ369C		(For Aluminum Drive Shaft)	UJ369C
	Clamp Kit (Rr. Shaft; Frt.)	UJ437-10		Clamp Kit (Rr. Shaft; Rr.)	UJ437-10
2004	Grand Cherokee w/ 4.7L Eng.: [Type 13]		2003	Liberty w/ 3.875" Yoke: [Type 17]	
	U-Joint (Fr. Shaft; Frt.)⊙	UJ369		U-Joint (Rr. Shaft; Frt.)⊙	UJ354
	Brute Force Greaseable	UJ280		Brute Force Greaseable	UJ270
	Brute Force Non Greaseable	UJ269		Brute Force Non Greaseable	UJ254
	(For Aluminum Drive Shaft)	UJ369C		(For Aluminum Drive Shaft)	UJ354C
	Clamp Kit (Fr. Shaft; Frt.)	UJ437-10		Clamp Kit (Rr. Shaft; Frt.)	UJ437-10
	U-Joint (Fr. Shaft; Rr.)⊙	[2] UJ380		U-Joint (Rr. Shaft; Rr.)⊙	UJ354
	Brute Force Greaseable	UJ280		Brute Force Greaseable	UJ270
	Brute Force Non Greaseable	UJ269		Brute Force Non Greaseable	UJ254
	(For Aluminum Drive Shaft)	UJ369C		(For Aluminum Drive Shaft)	UJ354C
	Clamp Kit (Rr. Shaft; Frt.)	UJ437-10		Clamp Kit (Rr. Shaft; Rr.)	UJ437-10
	U-Joint (Rr. Shaft; Rr.)⊙	UJ369		2003-2002 Grand Cherokee w/ 4.7L Eng. Exc.	
	Brute Force Greaseable	UJ280		Selec-Trac: [Type 13]	
	Brute Force Non Greaseable	UJ269		U-Joint (Fr. Shaft; Frt.)⊙	UJ369
	(For Aluminum Drive Shaft)	UJ369C		Brute Force Greaseable	UJ280
	Clamp Kit (Fr. Shaft; Frt.)	UJ437-10		Brute Force Non Greaseable	UJ269
	U-Joint (Fr. Shaft; Rr.)⊙	[2] UJ380		(For Aluminum Drive Shaft)	UJ369C
	Brute Force Greaseable	UJ280		Clamp Kit (Fr. Shaft; Frt.)	UJ437-10
	Brute Force Non Greaseable	UJ269		U-Joint (Fr. Shaft; Rr.)⊙	[2] UJ380
	(For Aluminum Drive Shaft)	UJ369C		Brute Force Greaseable	UJ280
	Clamp Kit (Rr. Shaft; Frt.)	UJ437-10		Brute Force Non Greaseable	UJ269
	U-Joint (Rr. Shaft; Rr.)⊙	UJ369		U-Joint (Rr. Shaft; Frt.)⊙	UJ369
	Brute Force Greaseable	UJ280		Brute Force Greaseable	UJ280
	Brute Force Non Greaseable	UJ269		Brute Force Non Greaseable	UJ269
	(For Aluminum Drive Shaft)	UJ369C		(For Aluminum Drive Shaft)	UJ369C
	Clamp Kit (Rr. Shaft; Rr.)	UJ437-10		Clamp Kit (Rr. Shaft; Frt.)	UJ437-10
	H Yoke	UJ647		U-Joint (Rr. Shaft; Rr.)⊙	UJ369
2004	Liberty: [Type 17]			Brute Force Greaseable	UJ280
	U-Joint (Rr. Shaft; Frt.)⊙	UJ369		Brute Force Non Greaseable	UJ269
	Brute Force Greaseable	UJ280		(For Aluminum Drive Shaft)	UJ369C
	Brute Force Non Greaseable	UJ269		Clamp Kit (Rr. Shaft; Rr.)	UJ437-10
	(For Aluminum Drive Shaft)	UJ369C		H Yoke	UJ647
	Clamp Kit (Rr. Shaft; Frt.)	UJ437-10			(Continued)
	U-Joint (Rr. Shaft; Rr.)⊙	UJ369			
	Brute Force Greaseable	UJ280			
	Brute Force Non Greaseable	UJ269			
	(For Aluminum Drive Shaft)	UJ369C			
	Clamp Kit (Rr. Shaft; Rr.)	UJ437-10			

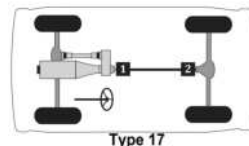
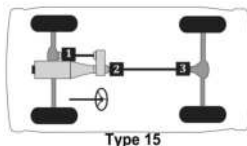
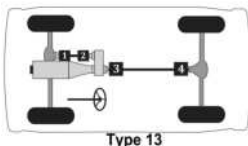

Passenger cars, light & medium trucks

(Cont.) -- Jeep Cherokee (thru 2001), Comanche, Commander, Grand Cherokee, Liberty, Wagoneer

MFG./YEAR	MODEL & LOCATION	PART NO.	MFG./YEAR	MODEL & LOCATION	PART NO.
Drive Shaft (4 W/D) (Cont.)			Drive Shaft (4 W/D) (Cont.)		
U-Joint (Cont.)			U-Joint (Cont.)		
2003-2002 Grand Cherokee w/ 4.7L Eng. & Selec-Trac: [Type 13]			2002 Liberty w/ 3.7L Eng.: [Type 17]		
	U-Joint (Fr. Shaft; Frt.) ①	UJ369		U-Joint (Rr. Shaft; Frt.) ①	UJ354
	<i>Brute Force Greaseable</i>	UJ280		<i>Brute Force Greaseable</i>	UJ270
	<i>Brute Force Non Greaseable</i>	UJ269		<i>Brute Force Non Greaseable</i>	UJ254
	(For Aluminum Drive Shaft)	UJ369C		(For Aluminum Drive Shaft)	UJ354C
	Clamp Kit (Fr. Shaft; Frt.)	UJ437-10		U-Joint (Rr. Shaft; Rr.) ②	UJ354
	U-Joint (Fr. Shaft; Rr.) ②	[2] UJ380		<i>Brute Force Greaseable</i>	UJ270
	<i>Brute Force Greaseable</i>	UJ280		<i>Brute Force Non Greaseable</i>	UJ254
	<i>Brute Force Non Greaseable</i>	UJ269		(For Aluminum Drive Shaft)	UJ354C
	U-Joint (Rr. Shaft; Frt.) ③	UJ354	2001 Grand Cherokee w/ 4.0L Eng.: [Type 17]		
	<i>Brute Force Greaseable</i>	UJ270		U-Joint (Rr. Shaft; Frt.) ①	UJ369
	<i>Brute Force Non Greaseable</i>	UJ254		<i>Brute Force Greaseable</i>	UJ280
	(For Aluminum Drive Shaft)	UJ354C		<i>Brute Force Non Greaseable</i>	UJ269
	U-Joint (Rr. Shaft; Rr.) ④	UJ369		(For Aluminum Drive Shaft)	UJ369C
	<i>Brute Force Greaseable</i>	UJ280		Clamp Kit (Rr. Shaft; Frt.)	UJ437-10
	<i>Brute Force Non Greaseable</i>	UJ269		U-Joint (Rr. Shaft; Rr.) ⑤	UJ369
	(For Aluminum Drive Shaft)	UJ369C		<i>Brute Force Greaseable</i>	UJ280
	Clamp Kit (Rr. Shaft; Rr.)	UJ437-10		<i>Brute Force Non Greaseable</i>	UJ269
	H Yoke	UJ647		(For Aluminum Drive Shaft)	UJ369C
	2003-2002 Grand Cherokee w/ 4.0L Eng.: [Type 15]			Clamp Kit (Rr. Shaft; Rr.)	UJ437-10
	U-Joint (Fr. Shaft; Frt.) ①	UJ369	2001 Grand Cherokee w/ 4.7L Eng. & Selec-Trac: [Type 13]		
	<i>Brute Force Greaseable</i>	UJ280		U-Joint (Fr. Shaft; Frt.) ①	UJ369
	<i>Brute Force Non Greaseable</i>	UJ269		<i>Brute Force Greaseable</i>	UJ280
	(For Aluminum Drive Shaft)	UJ369C		<i>Brute Force Non Greaseable</i>	UJ269
	Clamp Kit (Fr. Shaft; Frt.)	UJ437-10		(For Aluminum Drive Shaft)	UJ369C
	U-Joint (Rr. Shaft; Frt.) ②	UJ369		Clamp Kit (Fr. Shaft; Frt.)	UJ437-10
	<i>Brute Force Greaseable</i>	UJ280		U-Joint (Fr. Shaft; Rr.) ②	[2] UJ380
	<i>Brute Force Non Greaseable</i>	UJ269		<i>Brute Force Greaseable</i>	UJ280
	(For Aluminum Drive Shaft)	UJ369C		<i>Brute Force Non Greaseable</i>	UJ269
	Clamp Kit (Rr. Shaft; Frt.)	UJ437-10		U-Joint (Rr. Shaft; Frt.) ③	UJ369
	U-Joint (Rr. Shaft; Rr.) ③	UJ369		<i>Brute Force Greaseable</i>	UJ280
	<i>Brute Force Greaseable</i>	UJ280		<i>Brute Force Non Greaseable</i>	UJ269
	<i>Brute Force Non Greaseable</i>	UJ269		(For Aluminum Drive Shaft)	UJ369C
	(For Aluminum Drive Shaft)	UJ369C		Clamp Kit (Rr. Shaft; Frt.)	UJ437-10
	Clamp Kit (Rr. Shaft; Rr.)	UJ437-10		U-Joint (Rr. Shaft; Rr.) ④	UJ354
	2002 Liberty w/ 2.4L Eng.: [Type 17]			<i>Brute Force Greaseable</i>	UJ270
	U-Joint (Rr. Shaft; Frt.) ①	UJ369		<i>Brute Force Non Greaseable</i>	UJ254
	<i>Brute Force Greaseable</i>	UJ280		(For Aluminum Drive Shaft)	UJ354C
	<i>Brute Force Non Greaseable</i>	UJ269		H Yoke	UJ647
	(For Aluminum Drive Shaft)	UJ369C			(Continued)
	Clamp Kit (Rr. Shaft; Frt.)	UJ437-10			
	U-Joint (Rr. Shaft; Rr.) ②	UJ369			
	<i>Brute Force Greaseable</i>	UJ280			
	<i>Brute Force Non Greaseable</i>	UJ269			
	(For Aluminum Drive Shaft)	UJ369C			
	Clamp Kit (Rr. Shaft; Rr.)	UJ437-10			

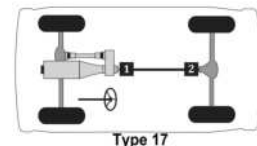
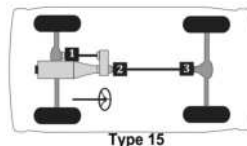
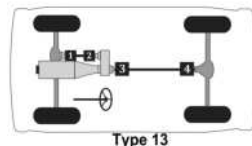

Passenger cars, light & medium trucks

Jeep Cherokee (thru 2001), Comanche, Commander, Grand Cherokee, Liberty, Wagoneer -- (Cont.)

MFG./YEAR	MODEL & LOCATION	PART NO.	MFG./YEAR	MODEL & LOCATION	PART NO.
Drive Shaft (4 W/D) (Cont.)			Drive Shaft (4 W/D) (Cont.)		
U-Joint (Cont.)			U-Joint (Cont.)		
2001	Grand Cherokee w/ 4.7L Eng. Exc. Selec-Trac: [Type 13]		2001-1999 Cherokee w/ Auto. Trans.: [Type 26]		
	U-Joint (Fr. Shaft; Frt.)⊙	UJ369		U-Joint (Fr. Shaft; Frt.)⊙	UJ369
	Brute Force Greaseable	UJ280		Brute Force Greaseable	UJ280
	Brute Force Non Greaseable	UJ269		Brute Force Non Greaseable	UJ269
	(For Aluminum Drive Shaft)	UJ369C		(For Aluminum Drive Shaft)	UJ369C
	Clamp Kit (Fr. Shaft; Frt.)	UJ437-10		Clamp Kit (Fr. Shaft; Frt.)	UJ437-10
	U-Joint (Fr. Shaft; Rr.)⊙	[2] UJ380		U-Joint (Fr. Shaft; Rr.)⊙	[2] UJ380
	Brute Force Greaseable	UJ280		Brute Force Greaseable	UJ280
	Brute Force Non Greaseable	UJ269		Brute Force Non Greaseable	UJ269
	U-Joint (Rr. Shaft; Frt.)⊙	UJ369		U-Joint (Rr. Shaft; Frt.)⊙	UJ369
	Brute Force Greaseable	UJ280		Brute Force Greaseable	UJ280
	Brute Force Non Greaseable	UJ269		Brute Force Non Greaseable	UJ269
	(For Aluminum Drive Shaft)	UJ369C		(For Aluminum Drive Shaft)	UJ369C
	Clamp Kit (Rr. Shaft; Frt.)	UJ437-10		Clamp Kit (Rr. Shaft; Frt.)	UJ437-10
	U-Joint (Rr. Shaft; Rr.)⊙	UJ369		U-Joint (Rr. Shaft; Rr.)⊙	UJ369
	Brute Force Greaseable	UJ280		Brute Force Greaseable	UJ280
	Brute Force Non Greaseable	UJ269		Brute Force Non Greaseable	UJ269
	(For Aluminum Drive Shaft)	UJ369C		(For Aluminum Drive Shaft)	UJ369C
	Clamp Kit (Rr. Shaft; Rr.)	UJ437-10		Clamp Kit (Rr. Shaft; Rr.)	UJ437-10
	H Yoke	UJ647		U-Joint (Wheel Joint)⊙	[2] UJ371
	2001-1999 Cherokee w/ Man. Trans.: [Type 26]			Brute Force Greaseable	UJ377
	U-Joint (Fr. Shaft; Frt.)⊙	UJ369		Brute Force Non Greaseable	UJ371
	Brute Force Greaseable	UJ280		H Yoke	UJ647
	Brute Force Non Greaseable	UJ269		Centering Ball Kit	UJ617
	(For Aluminum Drive Shaft)	UJ369C		2000-1999 Grand Cherokee w/ 4.0L Eng.: [Type 17]	
	Clamp Kit (Fr. Shaft; Frt.)	UJ437-10		U-Joint (Rr. Shaft; Frt.)⊙	UJ369
	U-Joint (Fr. Shaft; Rr.)⊙	[2] UJ380		Brute Force Greaseable	UJ280
	Brute Force Greaseable	UJ280		Brute Force Non Greaseable	UJ269
	Brute Force Non Greaseable	UJ269		(For Aluminum Drive Shaft)	UJ369C
	U-Joint (Rr. Shaft; Frt.)⊙	UJ354		Clamp Kit (Rr. Shaft; Frt.)	UJ437-10
	Brute Force Greaseable	UJ270		U-Joint (Rr. Shaft; Rr.)⊙	UJ369
	Brute Force Non Greaseable	UJ254		Brute Force Greaseable	UJ280
	(For Aluminum Drive Shaft)	UJ354C		Brute Force Non Greaseable	UJ269
	U-Joint (Rr. Shaft; Rr.)⊙	UJ369		(For Aluminum Drive Shaft)	UJ369C
	Brute Force Greaseable	UJ280		Clamp Kit (Rr. Shaft; Rr.)	UJ437-10
	Brute Force Non Greaseable	UJ269		2000-1999 Grand Cherokee w/ 4.7L Eng. & Selec-Trac: [Type 17]	
	(For Aluminum Drive Shaft)	UJ369C		U-Joint (Rr. Shaft; Frt.)⊙	UJ354
	Clamp Kit (Rr. Shaft; Rr.)	UJ437-10		Brute Force Greaseable	UJ270
	U-Joint (Wheel Joint)⊙	[2] UJ371		Brute Force Non Greaseable	UJ254
	Brute Force Greaseable	UJ377		(For Aluminum Drive Shaft)	UJ354C
	Brute Force Non Greaseable	UJ371		U-Joint (Rr. Shaft; Rr.)⊙	UJ369
	H Yoke	UJ647		Brute Force Greaseable	UJ280
	Centering Ball Kit	UJ617		Brute Force Non Greaseable	UJ269
				(For Aluminum Drive Shaft)	UJ369C
				Clamp Kit (Rr. Shaft; Rr.)	UJ437-10

(Continued)

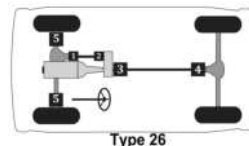
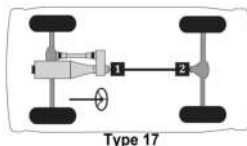
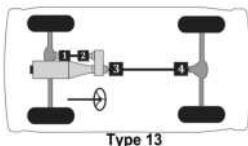

Passenger cars, light & medium trucks

(Cont.) -- Jeep Cherokee (thru 2001), Comanche, Commander, Grand Cherokee, Liberty, Wagoneer

MFG./YEAR	MODEL & LOCATION	PART NO.	MFG./YEAR	MODEL & LOCATION	PART NO.
Drive Shaft (4 W/D) (Cont.)			Drive Shaft (4 W/D) (Cont.)		
U-Joint (Cont.)			U-Joint (Cont.)		
2000-1999 Grand Cherokee w/ 4.7L Eng. Exc.			1998 Grand Cherokee w/ 5.9L Eng.: [Type		
Selec-Trac: [Type 17]			26]		
	U-Joint (Rr. Shaft; Frt.) [Ⓢ]	UJ369		U-Joint (Frt. Shaft; Frt.) [Ⓢ]	UJ369
	Brute Force Greaseable	UJ280		Brute Force Greaseable	UJ280
	Brute Force Non Greaseable	UJ269		Brute Force Non Greaseable	UJ269
	(For Aluminum Drive Shaft)	UJ369C		(For Aluminum Drive Shaft)	UJ369C
	Clamp Kit (Rr. Shaft; Frt.)	UJ437-10		Clamp Kit (Frt. Shaft; Frt.)	UJ437-10
	U-Joint (Rr. Shaft; Rr.) [Ⓢ]	UJ369		U-Joint (Frt. Shaft; Rr.) [Ⓢ]	UJ380 [2]
	Brute Force Greaseable	UJ280		Brute Force Greaseable	UJ280
	Brute Force Non Greaseable	UJ269		Brute Force Non Greaseable	UJ269
	(For Aluminum Drive Shaft)	UJ369C		U-Joint (Rr. Shaft; Frt.) [Ⓢ]	UJ354
	Clamp Kit (Rr. Shaft; Rr.)	UJ437-10		Brute Force Greaseable	UJ270
	1998 Grand Cherokee w/ 4.0L & 5.2L Eng.s:			Brute Force Non Greaseable	UJ254
	[Type 26]			(For Aluminum Drive Shaft)	UJ354C
	U-Joint (Frt. Shaft; Frt.) [Ⓢ]	UJ369		U-Joint (Rr. Shaft; Rr.) [Ⓢ]	UJ354
	Brute Force Greaseable	UJ280		Brute Force Greaseable	UJ270
	Brute Force Non Greaseable	UJ269		Brute Force Non Greaseable	UJ254
	(For Aluminum Drive Shaft)	UJ369C		(For Aluminum Drive Shaft)	UJ354C
	Clamp Kit (Frt. Shaft; Frt.)	UJ437-10		U-Joint (Wheel Joint) [Ⓢ]	UJ371 [2]
	U-Joint (Frt. Shaft; Rr.) [Ⓢ]	UJ380 [2]		Brute Force Greaseable	UJ377
	Brute Force Greaseable	UJ280		Brute Force Non Greaseable	UJ371
	Brute Force Non Greaseable	UJ269		H Yoke	UJ647
	U-Joint (Rr. Shaft; Frt.) [Ⓢ]	UJ369		Centering Ball Kit	UJ617
	Brute Force Greaseable	UJ280		1998-1996 Cherokee: [Type 26]	
	Brute Force Non Greaseable	UJ269		U-Joint (Frt. Shaft; Frt.) [Ⓢ]	UJ369
	(For Aluminum Drive Shaft)	UJ369C		Brute Force Greaseable	UJ280
	Clamp Kit (Rr. Shaft; Frt.)	UJ437-10		Brute Force Non Greaseable	UJ269
	U-Joint (Rr. Shaft; Rr.) [Ⓢ]	UJ369		(For Aluminum Drive Shaft)	UJ369C
	Brute Force Greaseable	UJ280		Clamp Kit (Frt. Shaft; Frt.)	UJ437-10
	Brute Force Non Greaseable	UJ269		U-Joint (Frt. Shaft; Rr.) [Ⓢ]	UJ380 [2]
	(For Aluminum Drive Shaft)	UJ369C		Brute Force Greaseable	UJ280
	Clamp Kit (Rr. Shaft; Rr.)	UJ437-10		Brute Force Non Greaseable	UJ269
	U-Joint (Wheel Joint) [Ⓢ]	UJ371 [2]		U-Joint (Rr. Shaft; Frt.) [Ⓢ]	UJ369
	Brute Force Greaseable	UJ377		Brute Force Greaseable	UJ280
	Brute Force Non Greaseable	UJ371		Brute Force Non Greaseable	UJ269
	H Yoke	UJ647		(For Aluminum Drive Shaft)	UJ369C
	Centering Ball Kit	UJ617		Clamp Kit (Rr. Shaft; Frt.)	UJ437-10
				U-Joint (Rr. Shaft; Rr.) [Ⓢ]	UJ369
				Brute Force Greaseable	UJ280
				Brute Force Non Greaseable	UJ269
				(For Aluminum Drive Shaft)	UJ369C
				Clamp Kit (Rr. Shaft; Rr.)	UJ437-10
				U-Joint (Wheel Joint) [Ⓢ]	UJ371 [2]
				Brute Force Greaseable	UJ377
				Brute Force Non Greaseable	UJ371
				H Yoke	UJ647
				Centering Ball Kit	UJ617

(Continued)

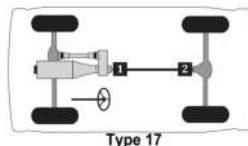

Type 17

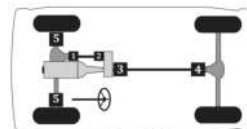

Type 26

Passenger cars, light & medium trucks

Jeep Cherokee (thru 2001), Comanche, Commander, Grand Cherokee, Liberty, Wagoneer -- (Cont.)

MFG./YEAR	MODEL & LOCATION	PART NO.	MFG./YEAR	MODEL & LOCATION	PART NO.
Drive Shaft (4 W/D) (Cont.)			Drive Shaft (4 W/D) (Cont.)		
U-Joint (Cont.)			U-Joint (Cont.)		
1997-1993 Grand Cherokee: [Type 26]			1995-1994 Cherokee w/o ABS: [Type 26]		
	U-Joint (Fr. Shaft; Frt.) ⊙	UJ369		U-Joint (Fr. Shaft; Frt.) ⊙	UJ369
	Brute Force Greaseable	UJ280		Brute Force Greaseable	UJ280
	Brute Force Non Greaseable	UJ269		Brute Force Non Greaseable	UJ269
	(For Aluminum Drive Shaft)	UJ369C		(For Aluminum Drive Shaft)	UJ369C
	Clamp Kit (Fr. Shaft; Frt.)	UJ437-10		Clamp Kit (Fr. Shaft; Frt.)	UJ437-10
	U-Joint (Fr. Shaft; Rr.) ⊙	[2] UJ380		U-Joint (Fr. Shaft; Rr.) ⊙	[2] UJ380
	Brute Force Greaseable	UJ280		Brute Force Greaseable	UJ280
	Brute Force Non Greaseable	UJ269		Brute Force Non Greaseable	UJ269
	U-Joint (Rr. Shaft; Frt.) ⊙	UJ369		U-Joint (Rr. Shaft; Frt.) ⊙	UJ369
	Brute Force Greaseable	UJ280		Brute Force Greaseable	UJ280
	Brute Force Non Greaseable	UJ269		Brute Force Non Greaseable	UJ269
	(For Aluminum Drive Shaft)	UJ369C		(For Aluminum Drive Shaft)	UJ369C
	Clamp Kit (Rr. Shaft; Frt.)	UJ437-10		Clamp Kit (Rr. Shaft; Frt.)	UJ437-10
	U-Joint (Rr. Shaft; Rr.) ⊙	UJ369		U-Joint (Rr. Shaft; Rr.) ⊙	UJ369
	Brute Force Greaseable	UJ280		Brute Force Greaseable	UJ280
	Brute Force Non Greaseable	UJ269		Brute Force Non Greaseable	UJ269
	(For Aluminum Drive Shaft)	UJ369C		(For Aluminum Drive Shaft)	UJ369C
	Clamp Kit (Rr. Shaft; Rr.)	UJ437-10		Clamp Kit (Rr. Shaft; Rr.)	UJ437-10
	U-Joint (Wheel Joint) ⊙	[2] UJ371		U-Joint (Wheel Joint) ⊙	[2] UJ365
	Brute Force Greaseable	UJ377		Brute Force Greaseable	UJ378
	Brute Force Non Greaseable	UJ371		Brute Force Non Greaseable	UJ365
	H Yoke	UJ647		H Yoke	UJ647
	Centering Ball Kit	UJ617		Centering Ball Kit	UJ617
1995-1994 Cherokee w/ ABS: [Type 26]			1993 Cherokee: [Type 26]		
	U-Joint (Fr. Shaft; Frt.) ⊙	UJ369		U-Joint (Fr. Shaft; Frt.) ⊙	UJ369
	Brute Force Greaseable	UJ280		Brute Force Greaseable	UJ280
	Brute Force Non Greaseable	UJ269		Brute Force Non Greaseable	UJ269
	(For Aluminum Drive Shaft)	UJ369C		(For Aluminum Drive Shaft)	UJ369C
	Clamp Kit (Fr. Shaft; Frt.)	UJ437-10		Clamp Kit (Fr. Shaft; Frt.)	UJ437-10
	U-Joint (Fr. Shaft; Rr.) ⊙	[2] UJ380		U-Joint (Fr. Shaft; Rr.) ⊙	[2] UJ380
	Brute Force Greaseable	UJ280		Brute Force Greaseable	UJ280
	Brute Force Non Greaseable	UJ269		Brute Force Non Greaseable	UJ269
	U-Joint (Rr. Shaft; Frt.) ⊙	UJ369		U-Joint (Rr. Shaft; Frt.) ⊙	UJ369
	Brute Force Greaseable	UJ280		Brute Force Greaseable	UJ280
	Brute Force Non Greaseable	UJ269		Brute Force Non Greaseable	UJ269
	(For Aluminum Drive Shaft)	UJ369C		(For Aluminum Drive Shaft)	UJ369C
	Clamp Kit (Rr. Shaft; Frt.)	UJ437-10		Clamp Kit (Rr. Shaft; Frt.)	UJ437-10
	U-Joint (Rr. Shaft; Rr.) ⊙	UJ369		U-Joint (Rr. Shaft; Rr.) ⊙	UJ369
	Brute Force Greaseable	UJ280		Brute Force Greaseable	UJ280
	Brute Force Non Greaseable	UJ269		Brute Force Non Greaseable	UJ269
	(For Aluminum Drive Shaft)	UJ369C		(For Aluminum Drive Shaft)	UJ369C
	Clamp Kit (Rr. Shaft; Rr.)	UJ437-10		Clamp Kit (Rr. Shaft; Rr.)	UJ437-10
	U-Joint (Wheel Joint) ⊙	[2] UJ371		U-Joint (Wheel Joint) ⊙	[2] UJ365
	Brute Force Greaseable	UJ377		Brute Force Greaseable	UJ378
	Brute Force Non Greaseable	UJ371		Brute Force Non Greaseable	UJ365
	H Yoke	UJ647		H Yoke	UJ647
	Centering Ball Kit	UJ617		Centering Ball Kit	UJ617

(Continued)

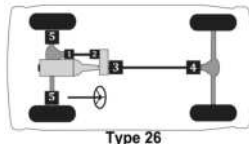

510 ▲ For Use w/ 1.063" Bearing Cap Application. ⊙ For Use w/ 1.188" Bearing Cap Application. ◇ For Use w/ Inner Lock Ring Application on Half Shaft. □ For Use w/ Outer Lock Ring Application on Half Shaft.

Passenger cars, light & medium trucks

(Cont.) -- Jeep Cherokee (thru 2001), Comanche, Commander, Grand Cherokee, Liberty, Wagoneer

MFG./YEAR	MODEL & LOCATION	PART NO.	MFG./YEAR	MODEL & LOCATION	PART NO.
Drive Shaft (4 W/D) (Cont.)			Drive Shaft (4 W/D) (Cont.)		
U-Joint (Cont.)			U-Joint (Cont.)		
1992 Cherokee: [Type 26]			1991-1984 Grand Wagoneer w/ U-Joints at Transfer Case: [Type 26]		
	U-Joint (Frnt. Shaft; Frnt.)	UJ369		U-Joint (Frnt. Shaft; Frnt.)	UJ369
	Brute Force Greaseable	UJ280		Brute Force Greaseable	UJ280
	Brute Force Non Greaseable	UJ269		Brute Force Non Greaseable	UJ269
	(For Aluminum Drive Shaft)	UJ369C		(For Aluminum Drive Shaft)	UJ369C
	Clamp Kit (Frnt. Shaft; Frnt.)	UJ437-10		Clamp Kit (Frnt. Shaft; Frnt.)	UJ437-10
	U-Joint (Frnt. Shaft; Rr.)	[2] UJ380		U-Joint (Frnt. Shaft; Rr.)	[2] UJ380
	Brute Force Greaseable	UJ280		Brute Force Greaseable	UJ280
	Brute Force Non Greaseable	UJ269		Brute Force Non Greaseable	UJ269
	U-Joint (Rr. Shaft; Frnt.)	UJ369		U-Joint (Rr. Shaft; Frnt.)	UJ369
	Brute Force Greaseable	UJ280		Brute Force Greaseable	UJ280
	Brute Force Non Greaseable	UJ269		Brute Force Non Greaseable	UJ269
	(For Aluminum Drive Shaft)	UJ369C		(For Aluminum Drive Shaft)	UJ369C
	Clamp Kit (Rr. Shaft; Frnt.)	UJ437-10		Clamp Kit (Rr. Shaft; Frnt.)	UJ437-10
	U-Joint (Rr. Shaft; Rr.)	UJ369		U-Joint (Rr. Shaft; Rr.)	UJ369
	Brute Force Greaseable	UJ280		Brute Force Greaseable	UJ280
	Brute Force Non Greaseable	UJ269		Brute Force Non Greaseable	UJ269
	(For Aluminum Drive Shaft)	UJ369C		(For Aluminum Drive Shaft)	UJ369C
	Clamp Kit (Rr. Shaft; Rr.)	UJ437-10		Clamp Kit (Rr. Shaft; Rr.)	UJ437-10
	U-Joint (Wheel Joint)	[2] UJ365		U-Joint (Wheel Joint)	[2] UJ365
	Brute Force Greaseable	UJ378		Brute Force Greaseable	UJ378
	Brute Force Non Greaseable	UJ365		Brute Force Non Greaseable	UJ365
	H Yoke	UJ647		H Yoke	UJ647
	Centering Ball Kit	UJ617		Centering Yoke	UJ607
	1992-1986 Comanche: [Type 26]			H Yoke	UJ647
	U-Joint (Frnt. Shaft; Frnt.)	UJ369		1991-1984 Grand Wagoneer w/ CV Joint at Transfer Case: [Type 28]	
	Brute Force Greaseable	UJ280		U-Joint (Frnt. Shaft; Frnt.)	UJ369
	Brute Force Non Greaseable	UJ269		Brute Force Greaseable	UJ280
	(For Aluminum Drive Shaft)	UJ369C		Brute Force Non Greaseable	UJ269
	Clamp Kit (Frnt. Shaft; Frnt.)	UJ437-10		(For Aluminum Drive Shaft)	UJ369C
	U-Joint (Frnt. Shaft; Rr.)	[2] UJ380		Clamp Kit (Frnt. Shaft; Frnt.)	UJ437-10
	Brute Force Greaseable	UJ280		U-Joint (Rr. Shaft; Frnt.)	UJ369
	Brute Force Non Greaseable	UJ269		Brute Force Greaseable	UJ280
	U-Joint (Rr. Shaft; Frnt.)	UJ369		Brute Force Non Greaseable	UJ269
	Brute Force Greaseable	UJ280		(For Aluminum Drive Shaft)	UJ369C
	Brute Force Non Greaseable	UJ269		Clamp Kit (Rr. Shaft; Frnt.)	UJ437-10
	(For Aluminum Drive Shaft)	UJ369C		U-Joint (Rr. Shaft; Rr.)	UJ369
	Clamp Kit (Rr. Shaft; Frnt.)	UJ437-10		Brute Force Greaseable	UJ280
	U-Joint (Rr. Shaft; Rr.)	UJ369		Brute Force Non Greaseable	UJ269
	Brute Force Greaseable	UJ280		(For Aluminum Drive Shaft)	UJ369C
	Brute Force Non Greaseable	UJ269		Clamp Kit (Rr. Shaft; Rr.)	UJ437-10
	(For Aluminum Drive Shaft)	UJ369C		U-Joint (Wheel Joint)	[2] UJ371
	Clamp Kit (Rr. Shaft; Rr.)	UJ437-10		Brute Force Greaseable	UJ377
	U-Joint (Wheel Joint)	[2] UJ365		Brute Force Non Greaseable	UJ371
	Brute Force Greaseable	UJ378		H Yoke	UJ647
	Brute Force Non Greaseable	UJ365			
	Centering Yoke	UJ607			
	H Yoke	UJ647			

(Continued)

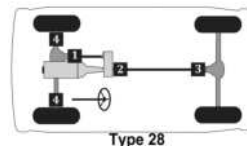
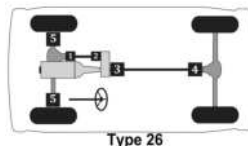

Passenger cars, light & medium trucks

Jeep Cherokee (thru 2001), Comanche, Commander, Grand Cherokee, Liberty, Wagoneer -- (Cont.)

MFG./YEAR	MODEL & LOCATION	PART NO.	MFG./YEAR	MODEL & LOCATION	PART NO.
-----------	------------------	----------	-----------	------------------	----------

Drive Shaft (4 W/D) (Cont.)

U-Joint (Cont.)

1991-1984 Cherokee w/ U-Joints at Transfer

Case: [Type 26]

U-Joint (Fr. Shaft; Frt.) [⊙]	UJ369
Brute Force Greaseable	UJ280
Brute Force Non Greaseable	UJ269
(For Aluminum Drive Shaft)	UJ369C
Clamp Kit (Fr. Shaft; Frt.)	UJ437-10
U-Joint (Fr. Shaft; Rr.) [⊙] [2]	UJ380
Brute Force Greaseable	UJ280
Brute Force Non Greaseable	UJ269
U-Joint (Rr. Shaft; Frt.) [⊙]	UJ369
Brute Force Greaseable	UJ280
Brute Force Non Greaseable	UJ269
(For Aluminum Drive Shaft)	UJ369C
Clamp Kit (Rr. Shaft; Frt.)	UJ437-10
U-Joint (Rr. Shaft; Rr.) [⊙]	UJ369
Brute Force Greaseable	UJ280
Brute Force Non Greaseable	UJ269
(For Aluminum Drive Shaft)	UJ369C
Clamp Kit (Rr. Shaft; Rr.)	UJ437-10
U-Joint (Wheel Joint) [⊙] [2]	UJ365
Brute Force Greaseable	UJ378
Brute Force Non Greaseable	UJ365
Centering Yoke	UJ607
H Yoke	UJ647

1991-1984 Cherokee w/ CV Joint at Transfer

Case: [Type 28]

U-Joint (Fr. Shaft; Frt.) [⊙]	UJ369
Brute Force Greaseable	UJ280
Brute Force Non Greaseable	UJ269
(For Aluminum Drive Shaft)	UJ369C
Clamp Kit (Fr. Shaft; Frt.)	UJ437-10
U-Joint (Rr. Shaft; Frt.) [⊙]	UJ369
Brute Force Greaseable	UJ280
Brute Force Non Greaseable	UJ269
(For Aluminum Drive Shaft)	UJ369C
Clamp Kit (Rr. Shaft; Frt.)	UJ437-10
U-Joint (Rr. Shaft; Rr.) [⊙]	UJ369
Brute Force Greaseable	UJ280
Brute Force Non Greaseable	UJ269
(For Aluminum Drive Shaft)	UJ369C
Clamp Kit (Rr. Shaft; Rr.)	UJ437-10
U-Joint (Wheel Joint) [⊙] [2]	UJ365
Brute Force Greaseable	UJ378
Brute Force Non Greaseable	UJ365
H Yoke	UJ647

Drive Shaft (4 W/D) (Cont.)

U-Joint (Cont.)

1990-1984 Wagoneer w/ U-Joints at Transfer

Case: [Type 26]

U-Joint (Fr. Shaft; Frt.) [⊙]	UJ369
Brute Force Greaseable	UJ280
Brute Force Non Greaseable	UJ269
(For Aluminum Drive Shaft)	UJ369C
Clamp Kit (Fr. Shaft; Frt.)	UJ437-10
U-Joint (Fr. Shaft; Rr.) [⊙] [2]	UJ380
Brute Force Greaseable	UJ280
Brute Force Non Greaseable	UJ269
U-Joint (Rr. Shaft; Frt.) [⊙]	UJ369
Brute Force Greaseable	UJ280
Brute Force Non Greaseable	UJ269
(For Aluminum Drive Shaft)	UJ369C
Clamp Kit (Rr. Shaft; Frt.)	UJ437-10
U-Joint (Rr. Shaft; Rr.) [⊙]	UJ369
Brute Force Greaseable	UJ280
Brute Force Non Greaseable	UJ269
(For Aluminum Drive Shaft)	UJ369C
Clamp Kit (Rr. Shaft; Rr.)	UJ437-10
U-Joint (Wheel Joint) [⊙] [2]	UJ365
Brute Force Greaseable	UJ378
Brute Force Non Greaseable	UJ365
H Yoke	UJ647

1990-1984 Wagoneer w/ CV Joint at Transfer

Case: [Type 28]

U-Joint (Fr. Shaft; Frt.) [⊙]	UJ369
Brute Force Greaseable	UJ280
Brute Force Non Greaseable	UJ269
(For Aluminum Drive Shaft)	UJ369C
Clamp Kit (Fr. Shaft; Frt.)	UJ437-10
U-Joint (Rr. Shaft; Frt.) [⊙]	UJ369
Brute Force Greaseable	UJ280
Brute Force Non Greaseable	UJ269
(For Aluminum Drive Shaft)	UJ369C
Clamp Kit (Rr. Shaft; Frt.)	UJ437-10
U-Joint (Rr. Shaft; Rr.) [⊙]	UJ369
Brute Force Greaseable	UJ280
Brute Force Non Greaseable	UJ269
(For Aluminum Drive Shaft)	UJ369C
Clamp Kit (Rr. Shaft; Rr.)	UJ437-10
U-Joint (Wheel Joint) [⊙] [2]	UJ365
Brute Force Greaseable	UJ378
Brute Force Non Greaseable	UJ365
H Yoke	UJ647

(Continued)

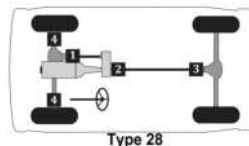
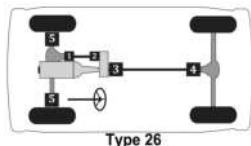

Passenger cars, light & medium trucks

(Cont.) -- Jeep Cherokee (thru 2001), Comanche, Commander, Grand Cherokee, Liberty, Wagoneer

MFG./YEAR	MODEL & LOCATION	PART NO.	MFG./YEAR	MODEL & LOCATION	PART NO.
Drive Shaft (4 W/D) (Cont.)			Drive Shaft (4 W/D) (Cont.)		
U-Joint (Cont.)			U-Joint (Cont.)		
1983-1980 Cherokee & Wagoneer: [Type 26]			1979-1974 Cherokee & Wagoneer w/ Man. Trans.:		
			[Type 26]		
	U-Joint (Frnt. Shaft; Frt.) ①	UJ369	U-Joint (Frnt. Shaft; Frt.) ①		UJ369
	<i>Brute Force Greaseable</i>	UJ280	<i>Brute Force Greaseable</i>		UJ280
	<i>Brute Force Non Greaseable</i>	UJ269	<i>Brute Force Non Greaseable</i>		UJ269
	(For Aluminum Drive Shaft)	UJ369C	(For Aluminum Drive Shaft)		UJ369C
	Clamp Kit (Frnt. Shaft; Frt.)	UJ437-10	U-Bolt Kit (Frnt. Shaft; Frt.)		UJ329-10
	U-Joint (Frnt. Shaft; Rr.) ②	[2] UJ380	U-Joint (Frnt. Shaft; Rr.) ②	[2]	UJ380
	<i>Brute Force Greaseable</i>	UJ280	<i>Brute Force Greaseable</i>		UJ280
	<i>Brute Force Non Greaseable</i>	UJ269	<i>Brute Force Non Greaseable</i>		UJ269
	U-Joint (Rr. Shaft; Frt.) ③	UJ369	U-Joint (Rr. Shaft; Rr.) ④		UJ315G
	<i>Brute Force Greaseable</i>	UJ280	<i>Brute Force Greaseable</i>		UJ246
	<i>Brute Force Non Greaseable</i>	UJ269	Clamp Kit (Rr. Shaft; Rr.)		UJ318-10
	(For Aluminum Drive Shaft)	UJ369C	U-Joint (Wheel Joint) ⑤	[2]	UJ371
	Clamp Kit (Rr. Shaft; Frt.)	UJ437-10	<i>Brute Force Greaseable</i>		UJ377
	U-Joint (Rr. Shaft; Rr.) ④	UJ369	<i>Brute Force Non Greaseable</i>		UJ371
	<i>Brute Force Greaseable</i>	UJ280	Centering Yoke		UJ607
	<i>Brute Force Non Greaseable</i>	UJ269	H Yoke		UJ647
	(For Aluminum Drive Shaft)	UJ369C	1973-1970 Wagoneer w/ Outer Lock Rings:		
	Clamp Kit (Rr. Shaft; Rr.)	UJ437-10	[Type 26]		
	U-Joint (Wheel Joint) ⑤	[2] UJ371	U-Joint (Frnt. Shaft; Frt.) ①		UJ369
	<i>Brute Force Greaseable</i>	UJ377	<i>Brute Force Greaseable</i>		UJ280
	<i>Brute Force Non Greaseable</i>	UJ371	<i>Brute Force Non Greaseable</i>		UJ269
	Centering Yoke	UJ607	(For Aluminum Drive Shaft)		UJ369C
	H Yoke	UJ647	U-Bolt Kit (Frnt. Shaft; Frt.)		UJ329-10
1979-1974 Cherokee & Wagoneer w/ Auto. Trans.: [Type 26]			U-Joint (Frnt. Shaft; Rr.) ②		UJ369
	U-Joint (Frnt. Shaft; Frt.) ①	UJ369	<i>Brute Force Greaseable</i>		UJ280
	<i>Brute Force Greaseable</i>	UJ280	<i>Brute Force Non Greaseable</i>		UJ269
	<i>Brute Force Non Greaseable</i>	UJ269	(For Aluminum Drive Shaft)		UJ369C
	(For Aluminum Drive Shaft)	UJ369C	U-Bolt Kit (Frnt. Shaft; Rr.)		UJ329-10
	U-Bolt Kit (Frnt. Shaft; Frt.)	UJ329-10	U-Joint (Rr. Shaft; Frt.) ③		UJ369
	U-Joint (Frnt. Shaft; Rr.) ②	[2] UJ380	<i>Brute Force Greaseable</i>		UJ280
	<i>Brute Force Greaseable</i>	UJ280	<i>Brute Force Non Greaseable</i>		UJ269
	<i>Brute Force Non Greaseable</i>	UJ269	(For Aluminum Drive Shaft)		UJ369C
	U-Joint (Rr. Shaft; Frt.) ③	UJ369	U-Bolt Kit (Rr. Shaft; Frt.)		UJ329-10
	<i>Brute Force Greaseable</i>	UJ280	U-Joint (Rr. Shaft; Rr.) ④		UJ369
	<i>Brute Force Non Greaseable</i>	UJ269	<i>Brute Force Greaseable</i>		UJ280
	(For Aluminum Drive Shaft)	UJ369C	<i>Brute Force Non Greaseable</i>		UJ269
	U-Bolt Kit (Rr. Shaft; Frt.)	UJ329-10	(For Aluminum Drive Shaft)		UJ369C
	U-Joint (Rr. Shaft; Rr.) ④	UJ369	U-Bolt Kit (Rr. Shaft; Rr.)		UJ329-10
	<i>Brute Force Greaseable</i>	UJ280	U-Joint (Wheel Joint) ⑤	[2]	UJ365
	<i>Brute Force Non Greaseable</i>	UJ269	<i>Brute Force Greaseable</i>		UJ378
	(For Aluminum Drive Shaft)	UJ369C	<i>Brute Force Non Greaseable</i>		UJ365
	U-Bolt Kit (Rr. Shaft; Rr.)	UJ329-10	(Continued)		
	U-Joint (Wheel Joint) ⑤	[2] UJ371			
	<i>Brute Force Greaseable</i>	UJ377			
	<i>Brute Force Non Greaseable</i>	UJ371			
	Centering Yoke	UJ607			
	H Yoke	UJ647			

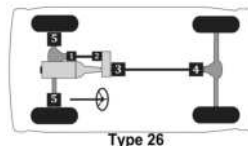

Passenger cars, light & medium trucks

Jeep Cherokee (thru 2001), Comanche, Commander, Grand Cherokee, Liberty, Wagoneer -- (Cont.)

MFG./YEAR	MODEL & LOCATION	PART NO.	MFG./YEAR	MODEL & LOCATION	PART NO.
Drive Shaft (4 W/D) (Cont.)			Drive Shaft (4 W/D) (Cont.)		
U-Joint (Cont.)			U-Joint (Cont.)		
1973-1970 Wagoneer w/ Inner Lock Rings:			1967-1966 Wagoneer w/ Outer Lock Rings:		
[Type 26]			[Type 26]		
U-Joint (Frt. Shaft; Frt.) ^①		UJ361	U-Joint (Frt. Shaft; Frt.) ^①		UJ369
U-Bolt Kit (Frt. Shaft; Frt.)		UJ329-10	<i>Brute Force Greaseable</i>		UJ280
U-Joint (Frt. Shaft; Rr.) ^②		UJ361	<i>Brute Force Non Greaseable</i>		UJ269
U-Bolt Kit (Frt. Shaft; Rr.)		UJ329-10	(For Aluminum Drive Shaft)		UJ369C
U-Joint (Rr. Shaft; Frt.) ^③		UJ361	U-Bolt Kit (Frt. Shaft; Frt.)		UJ329-10
U-Bolt Kit (Rr. Shaft; Frt.)		UJ329-10	U-Joint (Frt. Shaft; Rr.) ^②		UJ369
U-Joint (Rr. Shaft; Rr.) ^④		UJ361	<i>Brute Force Greaseable</i>		UJ280
U-Bolt Kit (Rr. Shaft; Rr.)		UJ329-10	<i>Brute Force Non Greaseable</i>		UJ269
U-Joint (Wheel Joint) ^⑤	[2]	UJ365	(For Aluminum Drive Shaft)		UJ369C
<i>Brute Force Greaseable</i>		UJ378	U-Bolt Kit (Frt. Shaft; Rr.)		UJ329-10
<i>Brute Force Non Greaseable</i>		UJ365	U-Joint (Rr. Shaft; Rr.) ^④		UJ315G
1969-1968 Wagoneer w/ 3.8L Eng.:		[Type 26]	<i>Brute Force Greaseable</i>		UJ246
U-Joint (Frt. Shaft; Frt.) ^①		UJ361	Clamp Kit (Rr. Shaft; Rr.)		UJ318-10
U-Bolt Kit (Frt. Shaft; Frt.)		UJ329-10	U-Joint (Wheel Joint) ^⑤	[2]	UJ365
U-Joint (Frt. Shaft; Rr.) ^②		UJ361	<i>Brute Force Greaseable</i>		UJ378
U-Bolt Kit (Frt. Shaft; Rr.)		UJ329-10	<i>Brute Force Non Greaseable</i>		UJ365
U-Joint (Rr. Shaft; Rr.) ^④		UJ315G	1967-1966 Wagoneer w/ Inner Lock Rings:		
<i>Brute Force Greaseable</i>		UJ246	[Type 26]		
Clamp Kit (Rr. Shaft; Rr.)		UJ318-10	U-Joint (Frt. Shaft; Frt.) ^①		UJ361
U-Joint (Wheel Joint) ^⑤	[2]	UJ365	U-Joint (Frt. Shaft; Rr.) ^②		UJ361
<i>Brute Force Greaseable</i>		UJ378	U-Joint (Rr. Shaft; Rr.) ^④		UJ315G
<i>Brute Force Non Greaseable</i>		UJ365	<i>Brute Force Greaseable</i>		UJ246
1969-1968 Wagoneer w/ 5.3L & 5.7L Eng.:		[Type 31]	Clamp Kit (Rr. Shaft; Rr.)		UJ318-10
[Type 31]			U-Joint (Wheel Joint) ^⑤	[2]	UJ365
U-Joint (Frt. Shaft; Frt.) ^①		UJ505	<i>Brute Force Greaseable</i>		UJ378
U-Bolt Kit (Frt. Shaft; Frt.)		UJ329-10	<i>Brute Force Non Greaseable</i>		UJ365
U-Joint (Frt. Shaft; Ctr.) ^②		UJ513	1965-1964 Wagoneer:		[Type 26]
U-Joint (Frt. Shaft; Rr.) ^③		UJ497	U-Joint (Frt. Shaft; Frt.) ^①		UJ361
U-Bolt Kit (Frt. Shaft; Rr.)		UJ329-10	U-Joint (Frt. Shaft; Rr.) ^②		UJ361
U-Joint (Rr. Shaft; Rr.) ^④		UJ315G	U-Joint (Rr. Shaft; Frt.) ^③		UJ507
<i>Brute Force Greaseable</i>		UJ246	U-Joint (Rr. Shaft; Rr.) ^④		UJ505
Clamp Kit (Rr. Shaft; Rr.)		UJ318-10	U-Bolt Kit (Rr. Shaft; Rr.)		UJ329-10
U-Joint (Wheel Joint) ^⑤	[2]	UJ365	U-Joint (Wheel Joint) ^⑤	[2]	UJ365
<i>Brute Force Greaseable</i>		UJ378	<i>Brute Force Greaseable</i>		UJ378
<i>Brute Force Non Greaseable</i>		UJ365	<i>Brute Force Non Greaseable</i>		UJ365

(Continued)

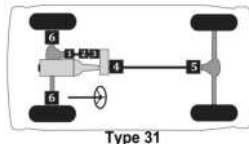
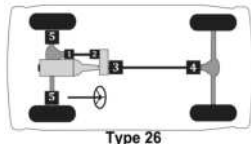

Passenger cars, light & medium trucks

(Cont.) -- Jeep Cherokee (thru 2001), Comanche, Commander, Grand Cherokee, Liberty, Wagoneer

MFG./YEAR	MODEL & LOCATION	PART NO.	MFG./YEAR	MODEL & LOCATION	PART NO.
Drive Shaft (4 W/D) (Cont.)			Drive Shaft (4 W/D) (Cont.)		
U-Joint (Cont.)			U-Joint (Cont.)		
			1963 Wagoneer: [Type 26]		
			U-Joint (Fr. Shaft; Fr.) ①		
			<i>Brute Force Greaseable</i> UJ280		
			<i>Brute Force Non Greaseable</i> UJ269		
			(For Aluminum Drive Shaft) UJ369C		
			U-Bolt Kit (Fr. Shaft; Fr.) UJ329-10		
			U-Joint (Fr. Shaft; Rr.) ②		
			<i>Brute Force Greaseable</i> UJ280		
			<i>Brute Force Non Greaseable</i> UJ269		
			(For Aluminum Drive Shaft) UJ369C		
			U-Bolt Kit (Fr. Shaft; Rr.) UJ329-10		
			U-Joint (Rr. Shaft; Fr.) ③		
			<i>Brute Force Greaseable</i> UJ280		
			<i>Brute Force Non Greaseable</i> UJ269		
			(For Aluminum Drive Shaft) UJ369C		
			U-Bolt Kit (Rr. Shaft; Fr.) UJ329-10		
			U-Joint (Rr. Shaft; Rr.) ④		
			<i>Brute Force Greaseable</i> UJ280		
			<i>Brute Force Non Greaseable</i> UJ269		
			(For Aluminum Drive Shaft) UJ369C		
			U-Bolt Kit (Rr. Shaft; Rr.) UJ329-10		
			U-Joint (Wheel Joint) ⑤		
			[2] UJ365		

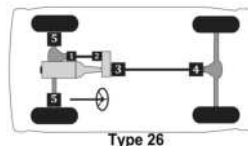

Passenger cars, light & medium trucks

Jeep F4 Pickup, Gladiator, J series

MFG./YEAR	MODEL & LOCATION	PART NO.	MFG./YEAR	MODEL & LOCATION	PART NO.
Drive Shaft (4 W/D)			Drive Shaft (4 W/D) (Cont.)		
U-Joint			U-Joint (Cont.)		
1988-1980 J Series: [Type 26]			1973-1970 J Series & Gladiator: [Type 26]		
	U-Joint (Frt. Shaft; Frt.) ⊙	UJ369		U-Joint (Frt. Shaft; Frt.) ⊙	UJ369
	<i>Brute Force Greaseable</i>	UJ280		<i>Brute Force Greaseable</i>	UJ280
	<i>Brute Force Non Greaseable</i>	UJ269		<i>Brute Force Non Greaseable</i>	UJ269
	(For Aluminum Drive Shaft)	UJ369C		(For Aluminum Drive Shaft)	UJ369C
	Clamp Kit (Frt. Shaft; Frt.)	UJ437-10		U-Bolt Kit (Frt. Shaft; Frt.)	UJ329-10
	U-Joint (Frt. Shaft; Rr.) ⊙	[2] UJ380		U-Joint (Frt. Shaft; Rr.) ⊙	UJ369
	<i>Brute Force Greaseable</i>	UJ280		<i>Brute Force Greaseable</i>	UJ280
	<i>Brute Force Non Greaseable</i>	UJ269		<i>Brute Force Non Greaseable</i>	UJ269
	U-Joint (Rr. Shaft; Frt.) ⊙	UJ369		(For Aluminum Drive Shaft)	UJ369C
	<i>Brute Force Greaseable</i>	UJ280		U-Bolt Kit (Frt. Shaft; Rr.)	UJ329-10
	<i>Brute Force Non Greaseable</i>	UJ269		U-Joint (Rr. Shaft; Frt.) ⊙	UJ369
	(For Aluminum Drive Shaft)	UJ369C		<i>Brute Force Greaseable</i>	UJ280
	Clamp Kit (Rr. Shaft; Frt.)	UJ437-10		<i>Brute Force Non Greaseable</i>	UJ269
	U-Joint (Rr. Shaft; Rr.) ⊙	UJ369		(For Aluminum Drive Shaft)	UJ369C
	<i>Brute Force Greaseable</i>	UJ280		U-Bolt Kit (Rr. Shaft; Frt.)	UJ329-10
	<i>Brute Force Non Greaseable</i>	UJ269		U-Joint (Rr. Shaft; Rr.) ⊙	UJ369
	(For Aluminum Drive Shaft)	UJ369C		<i>Brute Force Greaseable</i>	UJ280
	Clamp Kit (Rr. Shaft; Rr.)	UJ437-10		<i>Brute Force Non Greaseable</i>	UJ269
	U-Joint (Wheel Joint) ⊙	[2] UJ371		(For Aluminum Drive Shaft)	UJ369C
	<i>Brute Force Greaseable</i>	UJ377		U-Bolt Kit (Rr. Shaft; Rr.)	UJ329-10
	<i>Brute Force Non Greaseable</i>	UJ371		U-Joint (Wheel Joint) ⊙	[2] UJ365
	Centering Yoke	UJ607		<i>Brute Force Greaseable</i>	UJ378
	1979-1974 J Series: [Type 26]			<i>Brute Force Non Greaseable</i>	UJ365
	U-Joint (Frt. Shaft; Frt.) ⊙	UJ369		1969-1968 J Series & Gladiator w/ Outer Lock	
	<i>Brute Force Greaseable</i>	UJ280		Rings: [Type 26]	
	<i>Brute Force Non Greaseable</i>	UJ269		U-Joint (Frt. Shaft; Frt.) ⊙	UJ369
	(For Aluminum Drive Shaft)	UJ369C		<i>Brute Force Greaseable</i>	UJ280
	U-Bolt Kit (Frt. Shaft; Frt.)	UJ329-10		<i>Brute Force Non Greaseable</i>	UJ269
	U-Joint (Frt. Shaft; Rr.) ⊙	[2] UJ380		(For Aluminum Drive Shaft)	UJ369C
	<i>Brute Force Greaseable</i>	UJ280		U-Bolt Kit (Frt. Shaft; Frt.)	UJ329-10
	<i>Brute Force Non Greaseable</i>	UJ269		U-Joint (Frt. Shaft; Rr.) ⊙	UJ369
	U-Joint (Rr. Shaft; Frt.) ⊙	UJ369		<i>Brute Force Greaseable</i>	UJ280
	<i>Brute Force Greaseable</i>	UJ280		<i>Brute Force Non Greaseable</i>	UJ269
	<i>Brute Force Non Greaseable</i>	UJ269		(For Aluminum Drive Shaft)	UJ369C
	(For Aluminum Drive Shaft)	UJ369C		U-Bolt Kit (Frt. Shaft; Rr.)	UJ329-10
	U-Bolt Kit (Rr. Shaft; Frt.)	UJ329-10		U-Joint (Rr. Shaft; Frt.) ⊙	UJ369
	U-Joint (Rr. Shaft; Rr.) ⊙	UJ369		<i>Brute Force Greaseable</i>	UJ280
	<i>Brute Force Greaseable</i>	UJ280		<i>Brute Force Non Greaseable</i>	UJ269
	<i>Brute Force Non Greaseable</i>	UJ269		(For Aluminum Drive Shaft)	UJ369C
	(For Aluminum Drive Shaft)	UJ369C		U-Bolt Kit (Rr. Shaft; Frt.)	UJ329-10
	U-Bolt Kit (Rr. Shaft; Rr.)	UJ329-10		U-Joint (Rr. Shaft; Rr.) ⊙	UJ369
	U-Joint (Wheel Joint) ⊙	[2] UJ371		<i>Brute Force Greaseable</i>	UJ280
	<i>Brute Force Greaseable</i>	UJ377		<i>Brute Force Non Greaseable</i>	UJ269
	<i>Brute Force Non Greaseable</i>	UJ371		(For Aluminum Drive Shaft)	UJ369C
	Centering Yoke	UJ607		U-Bolt Kit (Rr. Shaft; Rr.)	UJ329-10
				U-Joint (Wheel Joint) ⊙	[2] UJ365
				<i>Brute Force Greaseable</i>	UJ378
				<i>Brute Force Non Greaseable</i>	UJ365

(Continued)

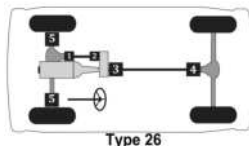

Passenger cars, light & medium trucks

(Cont.) -- Jeep F4 Pickup, Gladiator, J series

MFG./YEAR	MODEL & LOCATION	PART NO.	MFG./YEAR	MODEL & LOCATION	PART NO.
Drive Shaft (4 W/D) (Cont.)			Drive Shaft (4 W/D) (Cont.)		
U-Joint (Cont.)			U-Joint (Cont.)		
1969-1968 J Series & Gladiator w/ Inner Lock			1962-1960 F4 Series Pickup: [Type 26]		
Rings: [Type 31]					
U-Joint (Frnt. Shaft; Frt.) ^①		UJ505	U-Joint (Frnt. Shaft; Frt.) ^①		UJ369
U-Joint (Frnt. Shaft; Ctr.) ^②		UJ513	Brute Force Greaseable		UJ280
U-Joint (Frnt. Shaft; Rr.) ^③		UJ497	Brute Force Non Greaseable		UJ269
U-Bolt Kit (Frnt. Shaft; Rr.)		UJ329-10	(For Aluminum Drive Shaft)		UJ369C
U-Joint (Rr. Shaft; Frt.) ^④		UJ369	U-Joint (Frnt. Shaft; Rr.) ^⑤		UJ369
Brute Force Greaseable		UJ280	Brute Force Greaseable		UJ280
Brute Force Non Greaseable		UJ269	Brute Force Non Greaseable		UJ269
(For Aluminum Drive Shaft)		UJ369C	(For Aluminum Drive Shaft)		UJ369C
U-Bolt Kit (Rr. Shaft; Frt.)		UJ329-10	U-Joint (Rr. Shaft; Frt.) ^⑥		UJ369
U-Joint (Rr. Shaft; Rr.) ^⑦		UJ369	Brute Force Greaseable		UJ280
Brute Force Greaseable		UJ280	Brute Force Non Greaseable		UJ269
Brute Force Non Greaseable		UJ269	(For Aluminum Drive Shaft)		UJ369C
(For Aluminum Drive Shaft)		UJ369C	U-Joint (Rr. Shaft; Rr.) ^⑧		UJ369
U-Bolt Kit (Rr. Shaft; Rr.)		UJ329-10	Brute Force Greaseable		UJ280
U-Joint (Wheel Joint) ^⑨	[2]	UJ365	Brute Force Non Greaseable		UJ269
Brute Force Greaseable		UJ378	(For Aluminum Drive Shaft)		UJ369C
Brute Force Non Greaseable		UJ365	U-Joint (Wheel Joint) ^⑩	[2]	UJ365
1967-1963 J Series & Gladiator: [Type 26]			Brute Force Greaseable		UJ378
U-Joint (Frnt. Shaft; Frt.) ^①		UJ369	Brute Force Non Greaseable		UJ365
Brute Force Greaseable		UJ280	1959-1957 F4 Series Pickup: [Type 26]		
Brute Force Non Greaseable		UJ269	U-Joint (Frnt. Shaft; Frt.) ^①		UJ369
(For Aluminum Drive Shaft)		UJ369C	Brute Force Greaseable		UJ280
U-Bolt Kit (Frnt. Shaft; Frt.)		UJ329-10	Brute Force Non Greaseable		UJ269
U-Joint (Frnt. Shaft; Rr.) ^②		UJ369	(For Aluminum Drive Shaft)		UJ369C
Brute Force Greaseable		UJ280	U-Joint (Frnt. Shaft; Rr.) ^②		UJ369
Brute Force Non Greaseable		UJ269	Brute Force Greaseable		UJ280
(For Aluminum Drive Shaft)		UJ369C	Brute Force Non Greaseable		UJ269
U-Bolt Kit (Frnt. Shaft; Rr.)		UJ329-10	(For Aluminum Drive Shaft)		UJ369C
U-Joint (Rr. Shaft; Frt.) ^③		UJ369	U-Joint (Rr. Shaft; Frt.) ^③		UJ369
Brute Force Greaseable		UJ280	Brute Force Greaseable		UJ280
Brute Force Non Greaseable		UJ269	Brute Force Non Greaseable		UJ269
(For Aluminum Drive Shaft)		UJ369C	(For Aluminum Drive Shaft)		UJ369C
U-Bolt Kit (Rr. Shaft; Frt.)		UJ329-10	U-Joint (Rr. Shaft; Rr.) ^④		UJ369
U-Joint (Rr. Shaft; Rr.) ^④		UJ369	Brute Force Greaseable		UJ280
Brute Force Greaseable		UJ280	Brute Force Non Greaseable		UJ269
Brute Force Non Greaseable		UJ269	(For Aluminum Drive Shaft)		UJ369C
(For Aluminum Drive Shaft)		UJ369C	U-Joint (Rr. Shaft; Rr.) ^④		UJ369
U-Bolt Kit (Rr. Shaft; Rr.)		UJ329-10	Brute Force Greaseable		UJ280
U-Joint (Rr. Shaft; Rr.) ^⑤		UJ369	Brute Force Non Greaseable		UJ269
Brute Force Greaseable		UJ280	(For Aluminum Drive Shaft)		UJ369C
Brute Force Non Greaseable		UJ269	U-Joint (Wheel Joint) ^⑤	[2]	UJ365
(For Aluminum Drive Shaft)		UJ369C	Brute Force Greaseable		UJ378
U-Bolt Kit (Rr. Shaft; Rr.)		UJ329-10	Brute Force Non Greaseable		UJ365
U-Joint (Wheel Joint) ^⑥	[2]	UJ365			
Brute Force Greaseable		UJ378			
Brute Force Non Greaseable		UJ365			

Kia CUV Niro, Seltos, Sorento, Sportage

Drive Shaft (AWD)

U-Joint

2010-2007 Sportage: [Type 44]

U-Joint (Front)^① UJ386

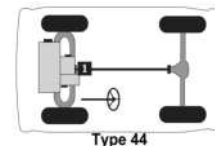
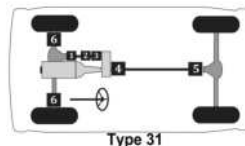
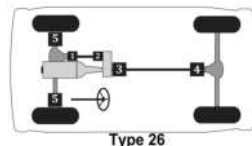

Passenger cars, light & medium trucks

(Cont.) -- Lexus Truck GX460, GX470, LX450, LX470, LX570

MFG./YEAR	MODEL & LOCATION	PART NO.	MFG./YEAR	MODEL & LOCATION	PART NO.
Drive Shaft (4 W/D) (Cont.)			Drive Shaft (AWD) (Cont.)		
U-Joint (Cont.)			U-Joint (Cont.)		
1997-1996 LX450: [Type 13]			2015-2013 LX570: [Type 13]		
	U-Joint (Frnt. Shaft; Frt.) ^①	UJ387		U-Joint (Frnt. Shaft; Frt.) ^①	UJ387
	Brute Force Greaseable	UJ285		Brute Force Greaseable	UJ285
	Brute Force Non Greaseable	UJ287		Brute Force Non Greaseable	UJ287
	U-Joint (Frnt. Shaft; Rr.) ^②	UJ387		U-Joint (Frnt. Shaft; Rr.) ^②	UJ387
	Brute Force Greaseable	UJ285		Brute Force Greaseable	UJ285
	Brute Force Non Greaseable	UJ287		Brute Force Non Greaseable	UJ287
	U-Joint (Rr. Shaft; Frt.) ^③	UJ389		U-Joint (Rr. Shaft; Frt.) ^③	UJ387
	U-Joint (Rr. Shaft; Rr.) ^④	UJ389		Brute Force Greaseable	UJ285
Drive Shaft (AWD)				Brute Force Non Greaseable	UJ287
U-Joint				U-Joint (Rr. Shaft; Rr.) ^④	UJ387
2019-2010 GX460: [Type 13]				Brute Force Greaseable	UJ285
	U-Joint (Frnt. Shaft; Frt.) ^①	UJ387		Brute Force Non Greaseable	UJ287
	Brute Force Greaseable	UJ285	2011-2008 LX570: [Type 13]		
	Brute Force Non Greaseable	UJ287		U-Joint (Frnt. Shaft; Frt.) ^①	UJ387
	U-Joint (Frnt. Shaft; Rr.) ^②	UJ387		Brute Force Greaseable	UJ285
	Brute Force Greaseable	UJ285		Brute Force Non Greaseable	UJ287
	Brute Force Non Greaseable	UJ287		U-Joint (Frnt. Shaft; Rr.) ^②	UJ387
	U-Joint (Rr. Shaft; Frt.) ^③	UJ387		Brute Force Greaseable	UJ285
	Brute Force Greaseable	UJ285		Brute Force Non Greaseable	UJ287
	Brute Force Non Greaseable	UJ287		U-Joint (Rr. Shaft; Frt.) ^③	UJ387
	U-Joint (Rr. Shaft; Rr.) ^④	UJ387		Brute Force Greaseable	UJ285
	Brute Force Greaseable	UJ285		Brute Force Non Greaseable	UJ287
	Brute Force Non Greaseable	UJ287		U-Joint (Rr. Shaft; Rr.) ^④	UJ387
				Brute Force Greaseable	UJ285
				Brute Force Non Greaseable	UJ287

Lincoln Truck Aviator

Drive Shaft (2 W/D)			Drive Shaft (AWD)		
U-Joint			U-Joint		
2005-2003 All: [Type 1]			2005-2003 All: [Type 15]		
	U-Joint (Front) ^①	UJ354		U-Joint (Frnt. Shaft; Frt.) ^①	UJ369
	Brute Force Greaseable	UJ270		Brute Force Greaseable	UJ280
	Brute Force Non Greaseable	UJ254		Brute Force Non Greaseable	UJ269
	(For Aluminum Drive Shaft)	UJ354C		(For Aluminum Drive Shaft)	UJ369C
	U-Joint (Rear) ^②	UJ354		Clamp Kit (Frnt. Shaft; Frt.)	UJ437-10
	Brute Force Greaseable	UJ270		U-Joint (Rr. Shaft; Frt.) ^②	UJ354
	Brute Force Non Greaseable	UJ254		Brute Force Greaseable	UJ270
	(For Aluminum Drive Shaft)	UJ354C		Brute Force Non Greaseable	UJ254
				(For Aluminum Drive Shaft)	UJ354C
				U-Joint (Rr. Shaft; Rr.) ^③	UJ354
				Brute Force Greaseable	UJ270
				Brute Force Non Greaseable	UJ254
				(For Aluminum Drive Shaft)	UJ354C

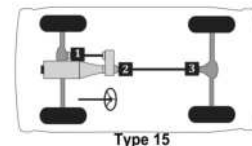
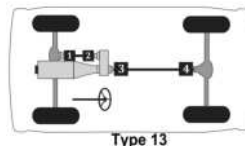
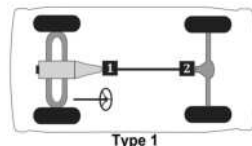

Lincoln Truck Blackwood

MFG./YEAR	MODEL & LOCATION	PART NO.	MFG./YEAR	MODEL & LOCATION	PART NO.
Drive Shaft (2 W/D)					
U-Joint					
2002 All: [Type 1]					
	U-Joint (Front)Ⓛ	UJ331			
	Brute Force Greaseable	UJ232			
	Brute Force Non Greaseable	UJ231			
	(For Aluminum Drive Shaft)	UJ331C			
	U-Joint (Rear)Ⓢ	UJ331			
	Brute Force Greaseable	UJ232			
	Brute Force Non Greaseable	UJ231			
	(For Aluminum Drive Shaft)	UJ331C			

Lincoln Truck Mark LT

Drive Shaft (2 W/D)			Drive Shaft (4 W/D)		
U-Joint			U-Joint		
2008-2006 2 Joint Shaft: [Type 1]			2008-2006 All: [Type 13]		
	U-Joint (Front)Ⓛ	UJ331	U-Joint (Fr. Shaft; Fr.)Ⓛ	UJ354	
	Brute Force Greaseable	UJ232	Brute Force Greaseable	UJ270	
	Brute Force Non Greaseable	UJ231	Brute Force Non Greaseable	UJ254	
	(For Aluminum Drive Shaft)	UJ331C	(For Aluminum Drive Shaft)	UJ354C	
	U-Joint (Rear)Ⓢ	UJ331	U-Joint (Fr. Shaft; Rr.)Ⓢ	UJ354	
	Brute Force Greaseable	UJ232	Brute Force Greaseable	UJ270	
	Brute Force Non Greaseable	UJ231	Brute Force Non Greaseable	UJ254	
	(For Aluminum Drive Shaft)	UJ331C	(For Aluminum Drive Shaft)	UJ354C	
	2008-2006 3 Joint Shaft: [Type 2]		U-Joint (Rr. Shaft; Fr.)Ⓢ	UJ331	
	U-Joint (Front)Ⓛ	UJ331	Brute Force Greaseable	UJ232	
	Brute Force Greaseable	UJ232	Brute Force Non Greaseable	UJ231	
	Brute Force Non Greaseable	UJ231	(For Aluminum Drive Shaft)	UJ331C	
	(For Aluminum Drive Shaft)	UJ331C	U-Joint (Rr. Shaft; Rr.)Ⓢ	UJ331	
	U-Joint (Center)Ⓢ	UJ331	Brute Force Greaseable	UJ232	
	Brute Force Greaseable	UJ232	Brute Force Non Greaseable	UJ231	
	Brute Force Non Greaseable	UJ231	(For Aluminum Drive Shaft)	UJ331C	
	(For Aluminum Drive Shaft)	UJ331C			
	U-Joint (Rear)Ⓢ	UJ331			
	Brute Force Greaseable	UJ232			
	Brute Force Non Greaseable	UJ231			
	(For Aluminum Drive Shaft)	UJ331C			

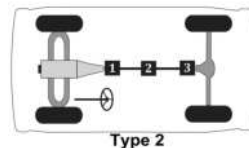
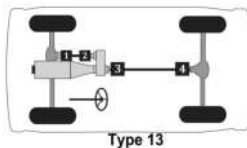
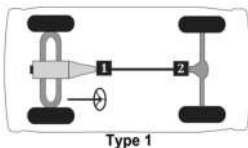

MFG./YEAR	MODEL & LOCATION	PART NO.	MFG./YEAR	MODEL & LOCATION	PART NO.
Drive Shaft (2 W/D)			Drive Shaft (4 W/D)		
U-Joint			U-Joint		
2021-2007 All: [Type 6]			2021-2007 All: [Type 17]		
	U-Joint (Center)⓪	UJ331		U-Joint (Rr. Shaft; Frt.)⓪	UJ331
	<i>Brute Force Greaseable</i>	UJ232		<i>Brute Force Greaseable</i>	UJ232
	<i>Brute Force Non Greaseable</i>	UJ231		<i>Brute Force Non Greaseable</i>	UJ231
	(For Aluminum Drive Shaft)	UJ331C		(For Aluminum Drive Shaft)	UJ331C
	U-Joint (Rear)⓪	UJ331		U-Joint (Rr. Shaft; Rr.)⓪	UJ331
	<i>Brute Force Greaseable</i>	UJ232		<i>Brute Force Greaseable</i>	UJ232
	<i>Brute Force Non Greaseable</i>	UJ231		<i>Brute Force Non Greaseable</i>	UJ231
	(For Aluminum Drive Shaft)	UJ331C		(For Aluminum Drive Shaft)	UJ331C
2006-2005 Exc. Staked U-Joints: [Type 6]			2006-1998 All: [Type 13]		
	U-Joint (Center)⓪	UJ354		U-Joint (Frt. Shaft; Frt.)⓪	UJ354
	<i>Brute Force Greaseable</i>	UJ270		<i>Brute Force Greaseable</i>	UJ270
	<i>Brute Force Non Greaseable</i>	UJ254		<i>Brute Force Non Greaseable</i>	UJ254
	(For Aluminum Drive Shaft)	UJ354C		(For Aluminum Drive Shaft)	UJ354C
	U-Joint (Rear)⓪	UJ354		U-Joint (Frt. Shaft; Rr.)⓪	UJ354
	<i>Brute Force Greaseable</i>	UJ270		<i>Brute Force Greaseable</i>	UJ270
	<i>Brute Force Non Greaseable</i>	UJ254		<i>Brute Force Non Greaseable</i>	UJ254
	(For Aluminum Drive Shaft)	UJ354C		(For Aluminum Drive Shaft)	UJ354C
2006-2005 w/ Staked U-Joints: [Type 1]				U-Joint (Rr. Shaft; Frt.)⓪	UJ331
	U-Joint (Front)⓪	[1] UJ30488		<i>Brute Force Greaseable</i>	UJ232
	U-Joint (Rear)⓪	[1] UJ30488		<i>Brute Force Non Greaseable</i>	UJ231
	(For Aluminum Drive Shaft)			(For Aluminum Drive Shaft)	UJ331C
2004-2003 All: [Type 7]				U-Joint (Rr. Shaft; Rr.)⓪	UJ331
	U-Joint (Rear)⓪	UJ331		<i>Brute Force Greaseable</i>	UJ232
	<i>Brute Force Greaseable</i>	UJ232		<i>Brute Force Non Greaseable</i>	UJ231
	<i>Brute Force Non Greaseable</i>	UJ231		(For Aluminum Drive Shaft)	UJ331C
	(For Aluminum Drive Shaft)	UJ331C		U-Joint (Rr. Shaft; Rr.)⓪	UJ331
2002-1998 All: [Type 1]				<i>Brute Force Greaseable</i>	UJ232
	U-Joint (Front)⓪	UJ331		<i>Brute Force Non Greaseable</i>	UJ231
	<i>Brute Force Greaseable</i>	UJ232		(For Aluminum Drive Shaft)	UJ331C
	<i>Brute Force Non Greaseable</i>	UJ231		U-Joint (Rear)⓪	UJ331
	(For Aluminum Drive Shaft)	UJ331C		<i>Brute Force Greaseable</i>	UJ232
	U-Joint (Rear)⓪	UJ331		<i>Brute Force Non Greaseable</i>	UJ231
	<i>Brute Force Greaseable</i>	UJ232		(For Aluminum Drive Shaft)	UJ331C
	<i>Brute Force Non Greaseable</i>	UJ231			
	(For Aluminum Drive Shaft)	UJ331C			

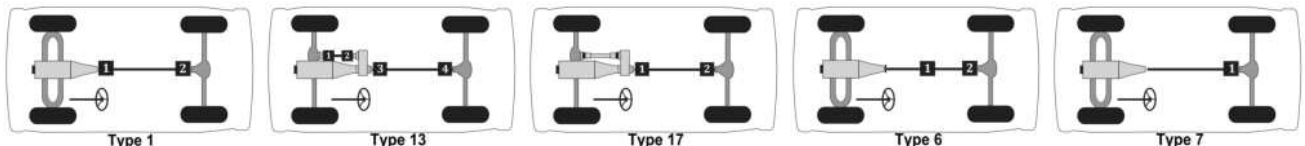

Passenger cars, light & medium trucks

Mazda CUV CX-30

MFG./YEAR	MODEL & LOCATION	PART NO.	MFG./YEAR	MODEL & LOCATION	PART NO.
Drive Shaft (4 W/D)			Drive Shaft (AWD)		
U-Joint			U-Joint		
2004-2001 Tribute: [Type 43]			2006-2005 Tribute: [Type 43]		
	U-Joint (Rr. Shaft; Ctr.) ①	UJ369		U-Joint (Rr. Shaft; Ctr.) ①	UJ369
	<i>Brute Force Greaseable</i>	UJ280		<i>Brute Force Greaseable</i>	UJ280
	<i>Brute Force Non Greaseable</i>	UJ269		<i>Brute Force Non Greaseable</i>	UJ269
	(For Aluminum Drive Shaft)	UJ369C		(For Aluminum Drive Shaft)	UJ369C
	Clamp Kit (Rr. Shaft; Ctr.)	UJ437-10		Clamp Kit (Rr. Shaft; Ctr.)	UJ437-10
	U-Joint (Rr. Shaft; Rr.) ②	UJ369		U-Joint (Rr. Shaft; Rr.) ②	UJ369
	<i>Brute Force Greaseable</i>	UJ280		<i>Brute Force Greaseable</i>	UJ280
	<i>Brute Force Non Greaseable</i>	UJ269		<i>Brute Force Non Greaseable</i>	UJ269
	(For Aluminum Drive Shaft)	UJ369C		(For Aluminum Drive Shaft)	UJ369C
	Clamp Kit (Rr. Shaft; Rr.)	UJ437-10		Clamp Kit (Rr. Shaft; Rr.)	UJ437-10

Mazda Truck B2000, B2200, B2300, B2500, B2600, B3000, B4000, Navajo

MFG./YEAR	MODEL & LOCATION	PART NO.	MFG./YEAR	MODEL & LOCATION	PART NO.
Drive Shaft (2 W/D)			Drive Shaft (2 W/D) (Cont.)		
U-Joint			U-Joint (Cont.)		
2009-1998 B2300, B2500, B3000 & B4000: [Type 1]			1997-1994 B2300, B3000 & B4000 w/ Cab Plus: [Type 2]		
	U-Joint (Front) ①	UJ354		U-Joint (Front) ①	UJ369
	<i>Brute Force Greaseable</i>	UJ270		<i>Brute Force Greaseable</i>	UJ280
	<i>Brute Force Non Greaseable</i>	UJ254		<i>Brute Force Non Greaseable</i>	UJ269
	(For Aluminum Drive Shaft)	UJ354C		(For Aluminum Drive Shaft)	UJ369C
	U-Joint (Rear) ②	UJ354		Clamp Kit (Front)	UJ437-10
	<i>Brute Force Greaseable</i>	UJ270		U-Joint (Center) ③	UJ369
	<i>Brute Force Non Greaseable</i>	UJ254		<i>Brute Force Greaseable</i>	UJ280
	(For Aluminum Drive Shaft)	UJ354C		<i>Brute Force Non Greaseable</i>	UJ269
	1997-1994 B2300, B3000 & B4000 w/ Regular Cab: [Type 1]			(For Aluminum Drive Shaft)	UJ369C
	U-Joint (Front) ①	UJ369		Clamp Kit (Center)	UJ437-10
	<i>Brute Force Greaseable</i>	UJ280		U-Joint (Rear) ④	UJ369
	<i>Brute Force Non Greaseable</i>	UJ269		<i>Brute Force Greaseable</i>	UJ280
	(For Aluminum Drive Shaft)	UJ369C		<i>Brute Force Non Greaseable</i>	UJ269
	Clamp Kit (Front)	UJ437-10		(For Aluminum Drive Shaft)	UJ369C
	U-Joint (Rear) ②	UJ369		Clamp Kit (Rear)	UJ437-10
	<i>Brute Force Greaseable</i>	UJ280		1994-1992 Navajo: [Type 1]	
	<i>Brute Force Non Greaseable</i>	UJ269		U-Joint (Front) ①	UJ369
	(For Aluminum Drive Shaft)	UJ369C		<i>Brute Force Greaseable</i>	UJ280
	Clamp Kit (Rear)	UJ437-10		<i>Brute Force Non Greaseable</i>	UJ269
				(For Aluminum Drive Shaft)	UJ369C
				U-Joint (Rear) ②	UJ369
				<i>Brute Force Greaseable</i>	UJ280
				<i>Brute Force Non Greaseable</i>	UJ269
				(For Aluminum Drive Shaft)	UJ369C
				1993-1987 B2200 & B2600: [Type 6]	
				U-Joint (Center) ①	UJ384
				1987-1986 B2000: [Type 6]	
				U-Joint (Center) ①	UJ384
				1984-1972 2 Joint Shaft: [Type 1]	
				U-Joint (Front) ①	UJ384
				U-Joint (Rear) ②	UJ384
				1984-1972 3 Joint Shaft: [Type 2]	
				U-Joint (Front) ①	UJ384
				U-Joint (Center) ②	UJ384
				U-Joint (Rear) ③	UJ384

(Continued)

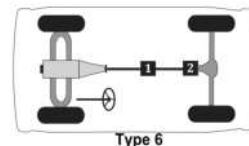
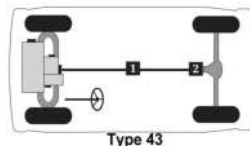
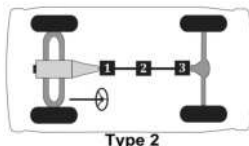
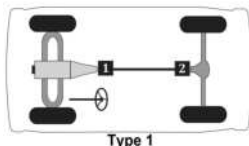

Passenger cars, light & medium trucks

(Cont.) -- Mazda Truck B2000, B2200, B2300, B2500, B2600, B3000, B4000, Navajo

MFG./YEAR	MODEL & LOCATION	PART NO.	MFG./YEAR	MODEL & LOCATION	PART NO.
Drive Shaft (4 W/D)			Drive Shaft (4 W/D) (Cont.)		
U-Joint			U-Joint (Cont.)		
2009-2002 B2300, B3000 & B4000: [Type 15]			1997-1994 B2300, B3000 & B4000 w/ 125" Wheelbase & 3 Joint Frt. Shaft: [Type 27]		
	U-Joint (Frt. Shaft; Frt.)①	UJ369		U-Joint (Frt. Shaft; Frt.)①	UJ369
	Brute Force Greaseable	UJ280		Brute Force Greaseable	UJ280
	Brute Force Non Greaseable	UJ269		Brute Force Non Greaseable	UJ269
	(For Aluminum Drive Shaft)	UJ369C		(For Aluminum Drive Shaft)	UJ369C
	Clamp Kit (Frt. Shaft; Frt.)	UJ437-10		Clamp Kit (Frt. Shaft; Frt.)	UJ437-10
	U-Joint (Rr. Shaft; Frt.)②	UJ354		U-Joint (Frt. Shaft; Rr.)②	[2] UJ379
	Brute Force Greaseable	UJ270		Brute Force Greaseable	UJ280
	Brute Force Non Greaseable	UJ254		Brute Force Non Greaseable	UJ269
	(For Aluminum Drive Shaft)	UJ354C		(For Aluminum Drive Shaft)	UJ369C
	U-Joint (Rr. Shaft; Rr.)③	UJ354		U-Joint (Rr. Shaft; Frt.)③	UJ369
	Brute Force Greaseable	UJ270		Brute Force Greaseable	UJ280
	Brute Force Non Greaseable	UJ254		Brute Force Non Greaseable	UJ269
	(For Aluminum Drive Shaft)	UJ354C		(For Aluminum Drive Shaft)	UJ369C
	2001-1998 B2300, B2500, B3000 & B4000 w/ Reg. Cab: [Type 22]			Clamp Kit (Rr. Shaft; Frt.)	UJ437-10
	U-Joint (Frt. Shaft; Frt.)①	UJ369		U-Joint (Rr. Shaft; Ctr.)④	UJ369
	Brute Force Greaseable	UJ280		Brute Force Greaseable	UJ280
	Brute Force Non Greaseable	UJ269		Brute Force Non Greaseable	UJ269
	(For Aluminum Drive Shaft)	UJ369C		(For Aluminum Drive Shaft)	UJ369C
	Clamp Kit (Frt. Shaft; Frt.)	UJ437-10		Clamp Kit (Rr. Shaft; Ctr.)	UJ437-10
	U-Joint (Rr. Shaft; Rr.)②	UJ354		U-Joint (Rr. Shaft; Rr.)⑤	UJ369
	Brute Force Greaseable	UJ270		Brute Force Greaseable	UJ280
	Brute Force Non Greaseable	UJ254		Brute Force Non Greaseable	UJ269
	(For Aluminum Drive Shaft)	UJ354C		(For Aluminum Drive Shaft)	UJ369C
	2001-1998 B2300, B2500, B3000 & B4000 w/ Cab Plus: [Type 15]			Clamp Kit (Rr. Shaft; Rr.)	UJ437-10
	U-Joint (Frt. Shaft; Frt.)①	UJ369		U-Joint (Wheel Joint)⑥	[3] UJ371
	Brute Force Greaseable	UJ280		Brute Force Greaseable	UJ377
	Brute Force Non Greaseable	UJ269		Brute Force Non Greaseable	UJ371
	(For Aluminum Drive Shaft)	UJ369C		H Yoke	UJ647
	Clamp Kit (Frt. Shaft; Frt.)	UJ437-10			(Continued)
	U-Joint (Rr. Shaft; Frt.)②	UJ354			
	Brute Force Greaseable	UJ270			
	Brute Force Non Greaseable	UJ254			
	(For Aluminum Drive Shaft)	UJ354C			
	U-Joint (Rr. Shaft; Rr.)③	UJ354			
	Brute Force Greaseable	UJ270			
	Brute Force Non Greaseable	UJ254			
	(For Aluminum Drive Shaft)	UJ354C			

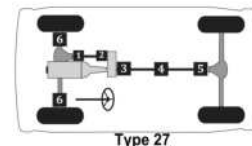
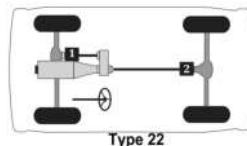
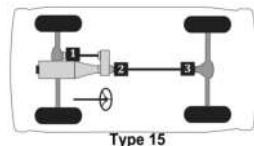

Passenger cars, light & medium trucks

Mazda Truck B2000, B2200, B2300, B2500, B2600, B3000, B4000, Navajo -- (Cont.)

MFG./YEAR	MODEL & LOCATION	PART NO.	MFG./YEAR	MODEL & LOCATION	PART NO.
Drive Shaft (4 W/D) (Cont.)			Drive Shaft (4 W/D) (Cont.)		
U-Joint (Cont.)			U-Joint (Cont.)		
1997-1994 B2300, B3000 & B4000 w/ 108" Wheelbase & 2 Joint Frt. Shaft: [Type 26]			1997-1994 B2300, B3000 & B4000 w/ 125" Wheelbase & 2 Joint Frt. Shaft: [Type 27]		
U-Joint (Frt. Shaft; Frt.)⊙		UJ369	U-Joint (Frt. Shaft; Frt.)⊙		UJ369
Brute Force Greaseable		UJ280	Brute Force Greaseable		UJ280
Brute Force Non Greaseable		UJ269	Brute Force Non Greaseable		UJ269
(For Aluminum Drive Shaft)		UJ369C	(For Aluminum Drive Shaft)		UJ369C
Clamp Kit (Frt. Shaft; Frt.)		UJ437-10	Clamp Kit (Frt. Shaft; Frt.)		UJ437-10
U-Joint (Frt. Shaft; Rr.)⊙		UJ369	U-Joint (Frt. Shaft; Rr.)⊙		UJ369
Brute Force Greaseable		UJ280	Brute Force Greaseable		UJ280
Brute Force Non Greaseable		UJ269	Brute Force Non Greaseable		UJ269
(For Aluminum Drive Shaft)		UJ369C	(For Aluminum Drive Shaft)		UJ369C
Clamp Kit (Frt. Shaft; Rr.)		UJ437-10	Clamp Kit (Frt. Shaft; Rr.)		UJ437-10
U-Joint (Rr. Shaft; Frt.)⊙	[2]	UJ379	U-Joint (Rr. Shaft; Frt.)⊙		UJ369
Brute Force Greaseable		UJ280	Brute Force Greaseable		UJ280
Brute Force Non Greaseable		UJ269	Brute Force Non Greaseable		UJ269
U-Joint (Rr. Shaft; Rr.)⊙		UJ369	U-Joint (Rr. Shaft; Rr.)⊙		UJ369C
Brute Force Greaseable		UJ280	Brute Force Greaseable		UJ280
Brute Force Non Greaseable		UJ269	Brute Force Non Greaseable		UJ269
(For Aluminum Drive Shaft)		UJ369C	(For Aluminum Drive Shaft)		UJ369C
Clamp Kit (Rr. Shaft; Rr.)		UJ437-10	Clamp Kit (Rr. Shaft; Frt.)		UJ437-10
U-Joint (Wheel Joint)⊙	[3]	UJ371	U-Joint (Rr. Shaft; Ctr.)⊙		UJ369
Brute Force Greaseable		UJ377	Brute Force Greaseable		UJ280
Brute Force Non Greaseable		UJ371	Brute Force Non Greaseable		UJ269
1997-1994 B2300, B3000 & B4000 w/ 114" Wheelbase & 2 Joint Frt. Shaft: [Type 26]			(For Aluminum Drive Shaft)		UJ369C
U-Joint (Frt. Shaft; Frt.)⊙		UJ369	Clamp Kit (Rr. Shaft; Rr.)		UJ437-10
Brute Force Greaseable		UJ280	U-Joint (Wheel Joint)⊙	[3]	UJ371
Brute Force Non Greaseable		UJ269	Brute Force Greaseable		UJ377
(For Aluminum Drive Shaft)		UJ369C	Brute Force Non Greaseable		UJ371
Clamp Kit (Frt. Shaft; Frt.)		UJ437-10			(Continued)
U-Joint (Frt. Shaft; Rr.)⊙		UJ369			
Brute Force Greaseable		UJ280			
Brute Force Non Greaseable		UJ269			
(For Aluminum Drive Shaft)		UJ369C			
Clamp Kit (Frt. Shaft; Rr.)		UJ437-10			
U-Joint (Rr. Shaft; Frt.)⊙		UJ354			
Brute Force Greaseable		UJ270			
Brute Force Non Greaseable		UJ254			
(For Aluminum Drive Shaft)		UJ354C			
U-Joint (Rr. Shaft; Rr.)⊙		UJ354			
Brute Force Greaseable		UJ270			
Brute Force Non Greaseable		UJ254			
(For Aluminum Drive Shaft)		UJ354C			
U-Joint (Wheel Joint)⊙	[3]	UJ371			
Brute Force Greaseable		UJ377			
Brute Force Non Greaseable		UJ371			

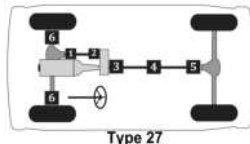
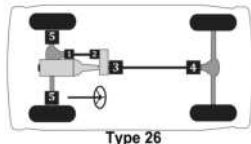

Passenger cars, light & medium trucks

(Cont.) -- Mazda Truck B2000, B2200, B2300, B2500, B2600, B3000, B4000, Navajo

MFG./YEAR	MODEL & LOCATION	PART NO.	MFG./YEAR	MODEL & LOCATION	PART NO.
Drive Shaft (4 W/D) (Cont.)			Drive Shaft (4 W/D) (Cont.)		
U-Joint (Cont.)			U-Joint (Cont.)		
1997-1994 B2300, B3000 & B4000 w/ 108" Wheelbase & 3 Joint Frt. Shaft: [Type 26]			1994-1993 Navajo: [Type 26]		
	U-Joint (Frt. Shaft; Frt.) ^①	UJ369		U-Joint (Frt. Shaft; Frt.) ^①	UJ369
	Brute Force Greaseable	UJ280		Brute Force Greaseable	UJ280
	Brute Force Non Greaseable	UJ269		Brute Force Non Greaseable	UJ269
	(For Aluminum Drive Shaft)	UJ369C		(For Aluminum Drive Shaft)	UJ369C
	Clamp Kit (Frt. Shaft; Frt.)	UJ437-10		Clamp Kit (Frt. Shaft; Frt.)	UJ437-10
	U-Joint (Frt. Shaft; Rr.) ^②	UJ369		U-Joint (Frt. Shaft; Rr.) ^②	UJ369
	Brute Force Greaseable	UJ280		Brute Force Greaseable	UJ280
	Brute Force Non Greaseable	UJ269		Brute Force Non Greaseable	UJ269
	(For Aluminum Drive Shaft)	UJ369C		(For Aluminum Drive Shaft)	UJ369C
	Clamp Kit (Frt. Shaft; Rr.)	UJ437-10		Clamp Kit (Frt. Shaft; Rr.)	UJ437-10
	U-Joint (Rr. Shaft; Frt.) ^③	[2] UJ379		U-Joint (Rr. Shaft; Frt.) ^③	UJ369
	Brute Force Greaseable	UJ280		Brute Force Greaseable	UJ280
	Brute Force Non Greaseable	UJ269		Brute Force Non Greaseable	UJ269
	(For Aluminum Drive Shaft)	UJ369C		(For Aluminum Drive Shaft)	UJ369C
	Clamp Kit (Rr. Shaft; Frt.)	UJ437-10		Clamp Kit (Rr. Shaft; Frt.)	UJ437-10
	U-Joint (Rr. Shaft; Rr.) ^④	UJ369		U-Joint (Rr. Shaft; Rr.) ^④	UJ369
	Brute Force Greaseable	UJ280		Brute Force Greaseable	UJ280
	Brute Force Non Greaseable	UJ269		Brute Force Non Greaseable	UJ269
	(For Aluminum Drive Shaft)	UJ369C		(For Aluminum Drive Shaft)	UJ369C
	Clamp Kit (Rr. Shaft; Rr.)	UJ437-10		Clamp Kit (Rr. Shaft; Rr.)	UJ437-10
	U-Joint (Wheel Joint) ^⑤	[3] UJ371		U-Joint (Wheel Joint) ^⑤	UJ371
	Brute Force Greaseable	UJ377		Brute Force Greaseable	UJ377
	Brute Force Non Greaseable	UJ371		Brute Force Non Greaseable	UJ371
	H Yoke	UJ647		Brute Force Greaseable	UJ377
				Brute Force Non Greaseable	UJ371
	1997-1994 B2300, B3000 & B4000 w/ 114" Wheelbase & 3 Joint Frt. Shaft: [Type 26]			1993-1987 B2200 & B2600 w/ Long Bed: [Type 14]	
	U-Joint (Frt. Shaft; Frt.) ^①	UJ369		U-Joint (Frt. Shaft; Frt.) ^①	UJ386
	Brute Force Greaseable	UJ280		U-Joint (Frt. Shaft; Rr.) ^②	UJ386
	Brute Force Non Greaseable	UJ269		U-Joint (Rr. Shaft; Frt.) ^③	UJ384
	(For Aluminum Drive Shaft)	UJ369C		U-Joint (Rr. Shaft; Ctr.) ^④	UJ384
	Clamp Kit (Frt. Shaft; Frt.)	UJ437-10		U-Joint (Rr. Shaft; Rr.) ^⑤	UJ384
	U-Joint (Frt. Shaft; Rr.) ^②	[2] UJ379		1993-1987 B2200 & B2600 w/ Std. Bed: [Type 13]	
	Brute Force Greaseable	UJ280		U-Joint (Frt. Shaft; Frt.) ^①	UJ386
	Brute Force Non Greaseable	UJ269		U-Joint (Frt. Shaft; Rr.) ^②	UJ386
	(For Aluminum Drive Shaft)	UJ369C		U-Joint (Rr. Shaft; Frt.) ^③	UJ384
	Clamp Kit (Frt. Shaft; Rr.)	UJ437-10		U-Joint (Rr. Shaft; Rr.) ^④	UJ384
	U-Joint (Rr. Shaft; Frt.) ^③	[2] UJ379		1993-1987 B2200 & B2600 w/ Cab Plus: [Type 14]	
	Brute Force Greaseable	UJ280		U-Joint (Frt. Shaft; Frt.) ^①	UJ386
	Brute Force Non Greaseable	UJ269		U-Joint (Frt. Shaft; Rr.) ^②	UJ386
	(For Aluminum Drive Shaft)	UJ369C		U-Joint (Rr. Shaft; Frt.) ^③	UJ384
	Clamp Kit (Rr. Shaft; Frt.)	UJ437-10		U-Joint (Rr. Shaft; Ctr.) ^④	UJ384
	U-Joint (Rr. Shaft; Rr.) ^④	UJ354		U-Joint (Rr. Shaft; Rr.) ^⑤	UJ384
	Brute Force Greaseable	UJ270			
	Brute Force Non Greaseable	UJ254			
	(For Aluminum Drive Shaft)	UJ354C			
	U-Joint (Rr. Shaft; Frt.) ^③	UJ354			
	Brute Force Greaseable	UJ270			
	Brute Force Non Greaseable	UJ254			
	(For Aluminum Drive Shaft)	UJ354C			
	U-Joint (Wheel Joint) ^⑤	[3] UJ371			
	Brute Force Greaseable	UJ377			
	Brute Force Non Greaseable	UJ371			
	H Yoke	UJ647			

(Continued)

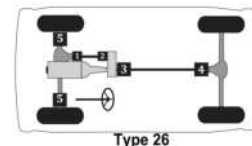
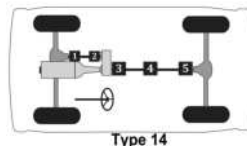
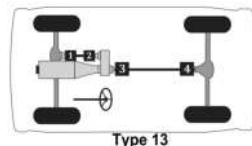

Passenger cars, light & medium trucks

Mazda Truck B2000, B2200, B2300, B2500, B2600, B3000, B4000, Navajo -- (Cont.)

MFG./YEAR	MODEL & LOCATION	PART NO.	MFG./YEAR	MODEL & LOCATION	PART NO.
Drive Shaft (4 W/D) (Cont.)			Drive Shaft (4 W/D) (Cont.)		
U-Joint (Cont.)			U-Joint (Cont.)		
1992-1991 Navajo w/ 1.063" Dia. Whl. Joint Brg.			1992-1991 Navajo w/ 1.188" Dia. Whl. Joint Brg.		
Caps: [Type 26]			Caps: [Type 26]		
	U-Joint (Fr. Shaft; Frt.)⊙	UJ369		U-Joint (Fr. Shaft; Frt.)⊙	UJ369
	Brute Force Greaseable	UJ280		Brute Force Greaseable	UJ280
	Brute Force Non Greaseable	UJ269		Brute Force Non Greaseable	UJ269
	(For Aluminum Drive Shaft)	UJ369C		(For Aluminum Drive Shaft)	UJ369C
	Clamp Kit (Fr. Shaft; Frt.)	UJ437-10		Clamp Kit (Fr. Shaft; Frt.)	UJ437-10
	U-Joint (Fr. Shaft; Rr.)⊙ [2]	UJ379		U-Joint (Fr. Shaft; Rr.)⊙ [2]	UJ379
	Brute Force Greaseable	UJ280		Brute Force Greaseable	UJ280
	Brute Force Non Greaseable	UJ269		Brute Force Non Greaseable	UJ269
	U-Joint (Rr. Shaft; Frt.)⊙	UJ369		U-Joint (Rr. Shaft; Frt.)⊙	UJ369
	Brute Force Greaseable	UJ280		Brute Force Greaseable	UJ280
	Brute Force Non Greaseable	UJ269		Brute Force Non Greaseable	UJ269
	(For Aluminum Drive Shaft)	UJ369C		(For Aluminum Drive Shaft)	UJ369C
	Clamp Kit (Rr. Shaft; Frt.)	UJ437-10		Clamp Kit (Rr. Shaft; Frt.)	UJ437-10
	U-Joint (Rr. Shaft; Rr.)⊙	UJ369		U-Joint (Rr. Shaft; Rr.)⊙	UJ369
	Brute Force Greaseable	UJ280		Brute Force Greaseable	UJ280
	Brute Force Non Greaseable	UJ269		Brute Force Non Greaseable	UJ269
	(For Aluminum Drive Shaft)	UJ369C		(For Aluminum Drive Shaft)	UJ369C
	Clamp Kit (Rr. Shaft; Rr.)	UJ437-10		Clamp Kit (Rr. Shaft; Rr.)	UJ437-10
	U-Joint (Wheel Joint)⊙ [3]	UJ436		U-Joint (Wheel Joint)⊙ [3]	UJ371
	Brute Force Greaseable	UJ466		Brute Force Greaseable	UJ377
	Brute Force Non Greaseable	UJ436		Brute Force Non Greaseable	UJ371
	H Yoke	UJ647		H Yoke	UJ647

Mercury CUV Mariner

Drive Shaft (4 W/D)

U-Joint

2007-2005 Mariner: [Type 43]

U-Joint (Rr. Shaft; Ctr.)⊙	UJ369
Brute Force Greaseable	UJ280
Brute Force Non Greaseable	UJ269
(For Aluminum Drive Shaft)	UJ369C
Clamp Kit (Rr. Shaft; Ctr.)	UJ437-10
U-Joint (Rr. Shaft; Rr.)⊙	UJ369
Brute Force Greaseable	UJ280
Brute Force Non Greaseable	UJ269
(For Aluminum Drive Shaft)	UJ369C
Clamp Kit (Rr. Shaft; Rr.)	UJ437-10

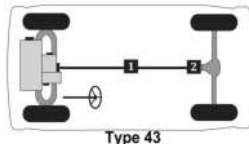
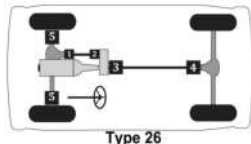

MFG./YEAR	MODEL & LOCATION	PART NO.	MFG./YEAR	MODEL & LOCATION	PART NO.
Drive Shaft (2 W/D)			Drive Shaft (4 W/D) (Cont.)		
U-Joint			U-Joint (Cont.)		
2010-1997 All: [Type 1]			1997 From 7/24/96: [Type 15]		
	U-Joint (Front) ①	UJ354		U-Joint (Fr. Shaft; Fr.) ①	UJ369
	<i>Brute Force Greaseable</i>	UJ270		<i>Brute Force Greaseable</i>	UJ280
	<i>Brute Force Non Greaseable</i>	UJ254		<i>Brute Force Non Greaseable</i>	UJ269
	(For Aluminum Drive Shaft)	UJ354C		(For Aluminum Drive Shaft)	UJ369C
	U-Joint (Rear) ②	UJ354		Clamp Kit (Fr. Shaft; Fr.)	UJ437-10
	<i>Brute Force Greaseable</i>	UJ270		U-Joint (Rr. Shaft; Fr.) ②	UJ354
	<i>Brute Force Non Greaseable</i>	UJ254		<i>Brute Force Greaseable</i>	UJ270
	(For Aluminum Drive Shaft)	UJ354C		<i>Brute Force Non Greaseable</i>	UJ254
				(For Aluminum Drive Shaft)	UJ354C
Drive Shaft (4 W/D)			U-Joint (Rr. Shaft; Rr.) ③		
U-Joint			<i>Brute Force Greaseable</i>		
2003-1998 All: [Type 15]			<i>Brute Force Non Greaseable</i>		
	U-Joint (Fr. Shaft; Fr.) ①	UJ369	Drive Shaft (AWD)		
	<i>Brute Force Greaseable</i>	UJ280	U-Joint		
	<i>Brute Force Non Greaseable</i>	UJ269	2010-2006 All: [Type 15]		
	(For Aluminum Drive Shaft)	UJ369C	U-Joint (Fr. Shaft; Fr.) ①		
	Clamp Kit (Fr. Shaft; Fr.)	UJ437-10	<i>Brute Force Greaseable</i>		
	U-Joint (Rr. Shaft; Fr.) ②	UJ354	<i>Brute Force Non Greaseable</i>		
	<i>Brute Force Greaseable</i>	UJ270	(For Aluminum Drive Shaft)		
	<i>Brute Force Non Greaseable</i>	UJ254	Clamp Kit (Fr. Shaft; Fr.)		
	(For Aluminum Drive Shaft)	UJ354C	U-Joint (Rr. Shaft; Fr.) ②		
	U-Joint (Rr. Shaft; Rr.) ③	UJ354	<i>Brute Force Greaseable</i>		
	<i>Brute Force Greaseable</i>	UJ270	<i>Brute Force Non Greaseable</i>		
	<i>Brute Force Non Greaseable</i>	UJ254	(For Aluminum Drive Shaft)		
	(For Aluminum Drive Shaft)	UJ354C	U-Joint (Rr. Shaft; Rr.) ③		
	1997 Thru 7/23/96: [Type 13]		<i>Brute Force Greaseable</i>		
	U-Joint (Fr. Shaft; Fr.) ①	UJ369	<i>Brute Force Non Greaseable</i>		
	<i>Brute Force Greaseable</i>	UJ280	(For Aluminum Drive Shaft)		
	<i>Brute Force Non Greaseable</i>	UJ269	Clamp Kit (Fr. Shaft; Fr.)		
	(For Aluminum Drive Shaft)	UJ369C	U-Joint (Rr. Shaft; Fr.) ②		
	Clamp Kit (Fr. Shaft; Fr.)	UJ437-10	<i>Brute Force Greaseable</i>		
	U-Joint (Fr. Shaft; Rr.) ②	[2] UJ379	<i>Brute Force Non Greaseable</i>		
	<i>Brute Force Greaseable</i>	UJ280	(For Aluminum Drive Shaft)		
	<i>Brute Force Non Greaseable</i>	UJ269	U-Joint (Rr. Shaft; Rr.) ③		
	U-Joint (Rr. Shaft; Fr.) ③	UJ354	<i>Brute Force Greaseable</i>		
	<i>Brute Force Greaseable</i>	UJ270	<i>Brute Force Non Greaseable</i>		
	<i>Brute Force Non Greaseable</i>	UJ254	(For Aluminum Drive Shaft)		
	(For Aluminum Drive Shaft)	UJ354C	U-Joint (Rr. Shaft; Rr.) ③		
	U-Joint (Rr. Shaft; Rr.) ④	UJ354	<i>Brute Force Greaseable</i>		
	<i>Brute Force Greaseable</i>	UJ270	<i>Brute Force Non Greaseable</i>		
	<i>Brute Force Non Greaseable</i>	UJ254	(For Aluminum Drive Shaft)		
	(For Aluminum Drive Shaft)	UJ354C	U-Joint (Rr. Shaft; Rr.) ④		
	H Yoke	UJ647	<i>Brute Force Greaseable</i>		
			<i>Brute Force Non Greaseable</i>		
			(For Aluminum Drive Shaft)		
			UJ354C		
			(Continued)		

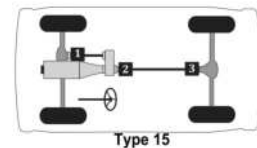
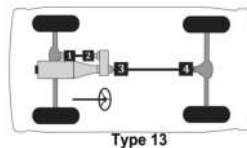
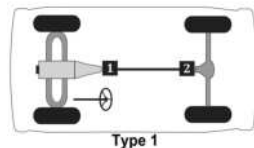

Passenger cars, light & medium trucks

Mercury Truck Mountaineer -- (Cont.)

MFG./YEAR	MODEL & LOCATION	PART NO.	MFG./YEAR	MODEL & LOCATION	PART NO.
Drive Shaft (AWD) (Cont.)			Drive Shaft (AWD) (Cont.)		
U-Joint (Cont.)			U-Joint (Cont.)		
1997	From 7/24/96: [Type 15]		1997	Thru 7/23/96: [Type 13]	
	U-Joint (Fr. Shaft; Frt.) ⊙	UJ369		U-Joint (Fr. Shaft; Frt.) ⊙	UJ369
	<i>Brute Force Greaseable</i>	UJ280		<i>Brute Force Greaseable</i>	UJ280
	<i>Brute Force Non Greaseable</i>	UJ269		<i>Brute Force Non Greaseable</i>	UJ269
	(For Aluminum Drive Shaft)	UJ369C		(For Aluminum Drive Shaft)	UJ369C
	Clamp Kit (Fr. Shaft; Frt.)	UJ437-10		Clamp Kit (Fr. Shaft; Frt.)	UJ437-10
	U-Joint (Rr. Shaft; Rr.) ⊙	UJ354		U-Joint (Fr. Shaft; Rr.) ⊙	[2] UJ379
	<i>Brute Force Greaseable</i>	UJ270		<i>Brute Force Greaseable</i>	UJ280
	<i>Brute Force Non Greaseable</i>	UJ254		<i>Brute Force Non Greaseable</i>	UJ269
	(For Aluminum Drive Shaft)	UJ354C		U-Joint (Rr. Shaft; Frt.) ⊙	UJ354
	U-Joint (Rr. Shaft; Rr.) ⊙	UJ354		<i>Brute Force Greaseable</i>	UJ270
	<i>Brute Force Greaseable</i>	UJ270		<i>Brute Force Non Greaseable</i>	UJ254
	<i>Brute Force Non Greaseable</i>	UJ254		(For Aluminum Drive Shaft)	UJ354C
	(For Aluminum Drive Shaft)	UJ354C		U-Joint (Rr. Shaft; Rr.) ⊙	UJ354
				<i>Brute Force Greaseable</i>	UJ270
				<i>Brute Force Non Greaseable</i>	UJ254
				(For Aluminum Drive Shaft)	UJ354C
				H Yoke	UJ647

Mitsubishi CUV Eclipse Cross, Endeavor, Outlander, Outlander Sport

Drive Shaft (AWD)	
U-Joint	
2006-2003 Outlander:	[Type 41]
U-Joint (Rr. Shaft; Frt.) ⊙	UJ398
U-Joint (Rr. Shaft; Rr.) ⊙	UJ398

Mitsubishi Truck Mighty Max, Montero, Montero Sport, Raider

<table border="1" style="width: 100%; border-collapse: collapse;"> <tbody> <tr> <td colspan="2">Drive Shaft (2 W/D)</td> </tr> <tr> <td colspan="2">U-Joint</td> </tr> <tr> <td>2009-2006 Raider w/ 2 Joint Shaft:</td> <td>[Type 1]</td> </tr> <tr> <td>U-Joint (Front)⊙</td> <td>UJ354</td> </tr> <tr> <td><i>Brute Force Greaseable</i></td> <td>UJ270</td> </tr> <tr> <td><i>Brute Force Non Greaseable</i></td> <td>UJ254</td> </tr> <tr> <td>(For Aluminum Drive Shaft)</td> <td>UJ354C</td> </tr> <tr> <td>U-Joint (Rear)⊙</td> <td>UJ354</td> </tr> <tr> <td><i>Brute Force Greaseable</i></td> <td>UJ270</td> </tr> <tr> <td><i>Brute Force Non Greaseable</i></td> <td>UJ254</td> </tr> <tr> <td>(For Aluminum Drive Shaft)</td> <td>UJ354C</td> </tr> </tbody> </table>	Drive Shaft (2 W/D)		U-Joint		2009-2006 Raider w/ 2 Joint Shaft:	[Type 1]	U-Joint (Front) ⊙	UJ354	<i>Brute Force Greaseable</i>	UJ270	<i>Brute Force Non Greaseable</i>	UJ254	(For Aluminum Drive Shaft)	UJ354C	U-Joint (Rear) ⊙	UJ354	<i>Brute Force Greaseable</i>	UJ270	<i>Brute Force Non Greaseable</i>	UJ254	(For Aluminum Drive Shaft)	UJ354C	<table border="1" style="width: 100%; border-collapse: collapse;"> <tbody> <tr> <td colspan="2">Drive Shaft (2 W/D) (Cont.)</td> </tr> <tr> <td colspan="2">U-Joint (Cont.)</td> </tr> <tr> <td>2009-2006 Raider w/ 3 Joint Shaft:</td> <td>[Type 2]</td> </tr> <tr> <td>U-Joint (Front)⊙</td> <td>UJ354</td> </tr> <tr> <td><i>Brute Force Greaseable</i></td> <td>UJ270</td> </tr> <tr> <td><i>Brute Force Non Greaseable</i></td> <td>UJ254</td> </tr> <tr> <td>(For Aluminum Drive Shaft)</td> <td>UJ354C</td> </tr> <tr> <td>U-Joint (Center)⊙</td> <td>UJ354</td> </tr> <tr> <td><i>Brute Force Greaseable</i></td> <td>UJ270</td> </tr> <tr> <td><i>Brute Force Non Greaseable</i></td> <td>UJ254</td> </tr> <tr> <td>(For Aluminum Drive Shaft)</td> <td>UJ354C</td> </tr> <tr> <td>U-Joint (Rear)⊙</td> <td>UJ354</td> </tr> <tr> <td><i>Brute Force Greaseable</i></td> <td>UJ270</td> </tr> <tr> <td><i>Brute Force Non Greaseable</i></td> <td>UJ254</td> </tr> <tr> <td>(For Aluminum Drive Shaft)</td> <td>UJ354C</td> </tr> <tr> <td>2003-2000 Montero Sport w/ 3.5L Eng.:</td> <td>[Type 6]</td> </tr> <tr> <td>U-Joint (Center)⊙</td> <td>UJ450</td> </tr> <tr> <td>U-Joint (Rear)⊙</td> <td>UJ450</td> </tr> <tr> <td>2003-1997 Montero Sport w/ 3.0L Eng.:</td> <td>[Type 2]</td> </tr> <tr> <td>U-Joint (Front)⊙</td> <td>UJ450</td> </tr> <tr> <td>U-Joint (Center)⊙</td> <td>UJ450</td> </tr> <tr> <td>U-Joint (Rear)⊙</td> <td>UJ450</td> </tr> </tbody> </table>	Drive Shaft (2 W/D) (Cont.)		U-Joint (Cont.)		2009-2006 Raider w/ 3 Joint Shaft:	[Type 2]	U-Joint (Front) ⊙	UJ354	<i>Brute Force Greaseable</i>	UJ270	<i>Brute Force Non Greaseable</i>	UJ254	(For Aluminum Drive Shaft)	UJ354C	U-Joint (Center) ⊙	UJ354	<i>Brute Force Greaseable</i>	UJ270	<i>Brute Force Non Greaseable</i>	UJ254	(For Aluminum Drive Shaft)	UJ354C	U-Joint (Rear) ⊙	UJ354	<i>Brute Force Greaseable</i>	UJ270	<i>Brute Force Non Greaseable</i>	UJ254	(For Aluminum Drive Shaft)	UJ354C	2003-2000 Montero Sport w/ 3.5L Eng.:	[Type 6]	U-Joint (Center) ⊙	UJ450	U-Joint (Rear) ⊙	UJ450	2003-1997 Montero Sport w/ 3.0L Eng.:	[Type 2]	U-Joint (Front) ⊙	UJ450	U-Joint (Center) ⊙	UJ450	U-Joint (Rear) ⊙	UJ450
Drive Shaft (2 W/D)																																																																			
U-Joint																																																																			
2009-2006 Raider w/ 2 Joint Shaft:	[Type 1]																																																																		
U-Joint (Front) ⊙	UJ354																																																																		
<i>Brute Force Greaseable</i>	UJ270																																																																		
<i>Brute Force Non Greaseable</i>	UJ254																																																																		
(For Aluminum Drive Shaft)	UJ354C																																																																		
U-Joint (Rear) ⊙	UJ354																																																																		
<i>Brute Force Greaseable</i>	UJ270																																																																		
<i>Brute Force Non Greaseable</i>	UJ254																																																																		
(For Aluminum Drive Shaft)	UJ354C																																																																		
Drive Shaft (2 W/D) (Cont.)																																																																			
U-Joint (Cont.)																																																																			
2009-2006 Raider w/ 3 Joint Shaft:	[Type 2]																																																																		
U-Joint (Front) ⊙	UJ354																																																																		
<i>Brute Force Greaseable</i>	UJ270																																																																		
<i>Brute Force Non Greaseable</i>	UJ254																																																																		
(For Aluminum Drive Shaft)	UJ354C																																																																		
U-Joint (Center) ⊙	UJ354																																																																		
<i>Brute Force Greaseable</i>	UJ270																																																																		
<i>Brute Force Non Greaseable</i>	UJ254																																																																		
(For Aluminum Drive Shaft)	UJ354C																																																																		
U-Joint (Rear) ⊙	UJ354																																																																		
<i>Brute Force Greaseable</i>	UJ270																																																																		
<i>Brute Force Non Greaseable</i>	UJ254																																																																		
(For Aluminum Drive Shaft)	UJ354C																																																																		
2003-2000 Montero Sport w/ 3.5L Eng.:	[Type 6]																																																																		
U-Joint (Center) ⊙	UJ450																																																																		
U-Joint (Rear) ⊙	UJ450																																																																		
2003-1997 Montero Sport w/ 3.0L Eng.:	[Type 2]																																																																		
U-Joint (Front) ⊙	UJ450																																																																		
U-Joint (Center) ⊙	UJ450																																																																		
U-Joint (Rear) ⊙	UJ450																																																																		

(Continued)

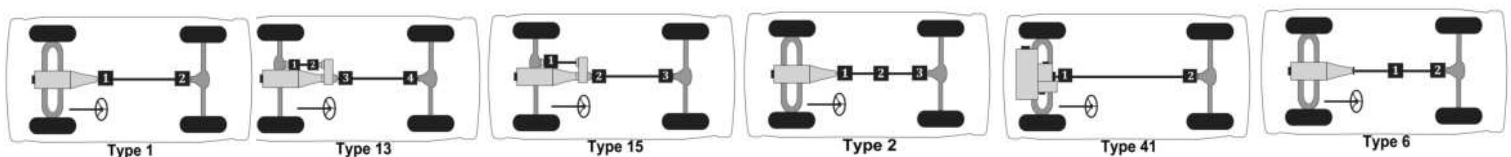

Passenger cars, light & medium trucks

(Cont.) -- Mitsubishi Truck Mighty Max, Montero, Montero Sport, Raider

MFG./YEAR	MODEL & LOCATION	PART NO.	MFG./YEAR	MODEL & LOCATION	PART NO.
Drive Shaft (2 W/D) (Cont.)			Drive Shaft (4 W/D)		
U-Joint (Cont.)			U-Joint		
1999-1997 Montero Sport w/ 2.4L Eng.: [Type 2]			2009-2006 Raider: [Type 15]		
	U-Joint (Front)ⓐ	UJ399		U-Joint (Frnt. Shaft; Frt.)ⓐ	UJ369
	U-Joint (Center)ⓑ	UJ399		Brute Force Greaseable	UJ280
	U-Joint (Rear)ⓐ	UJ399		Brute Force Non Greaseable	UJ269
1996-1989 Mighty Max w/ Standard Cab & Auto. Trans.: [Type 1]				(For Aluminum Drive Shaft)	UJ369C
	U-Joint (Front)ⓐ	UJ398		U-Joint (Rr. Shaft; Frt.)ⓑ	UJ354
	U-Joint (Rear)ⓑ	UJ398		Brute Force Greaseable	UJ270
1996-1989 Mighty Max w/ Standard Cab & Man. Trans.: [Type 1]				Brute Force Non Greaseable	UJ254
	U-Joint (Front)ⓐ	UJ399		(For Aluminum Drive Shaft)	UJ354C
	U-Joint (Rear)ⓑ	UJ399		U-Joint (Rr. Shaft; Rr.)ⓐ	UJ354
1996-1989 Mighty Max w/ Extended Cab & Auto. Trans.: [Type 2]				Brute Force Greaseable	UJ270
	U-Joint (Front)ⓐ	UJ398		Brute Force Non Greaseable	UJ254
	U-Joint (Center)ⓑ	UJ398		(For Aluminum Drive Shaft)	UJ354C
	U-Joint (Rear)ⓐ	UJ398	2006-2001 Montero: [Type 22]		
1996-1989 Mighty Max w/ Extended Cab & Man. Trans.: [Type 2]				U-Joint (Frnt. Shaft; Frt.)ⓐ	UJ398
	U-Joint (Front)ⓐ	UJ399	2004-2001 Montero Sport: [Type 15]		
	U-Joint (Center)ⓑ	UJ399		U-Joint (Frnt. Shaft; Frt.)ⓐ	UJ398
	U-Joint (Rear)ⓐ	UJ399		U-Joint (Rr. Shaft; Frt.)ⓑ	UJ450
1988-1983 Mighty Max w/ 2 Joint Shaft & 2.0L Eng.: [Type 1]				U-Joint (Rr. Shaft; Rr.)ⓐ	UJ450
	U-Joint (Front)ⓐ	UJ398	2000 Montero Sport: [Type 15]		
	U-Joint (Rear)ⓑ	UJ398		U-Joint (Frnt. Shaft; Frt.)ⓐ	UJ398
1988-1983 Mighty Max w/ 3 Joint Shaft & 2.0L Eng.: [Type 2]				U-Joint (Rr. Shaft; Frt.)ⓑ	UJ450
	U-Joint (Front)ⓐ	UJ398		U-Joint (Rr. Shaft; Rr.)ⓐ	UJ450
	U-Joint (Center)ⓑ	UJ398	2000-1999 Montero w/ Man. Trans.: [Type 22]		
	U-Joint (Rear)ⓐ	UJ398		U-Joint (Frnt. Shaft; Frt.)ⓐ	UJ398
1988-1983 Mighty Max w/ 2 Joint Shaft & 2.6L Eng.: [Type 1]				2000-1999 Montero w/ Auto. Trans.: [Type 22]	
	U-Joint (Front)ⓐ	UJ399		U-Joint (Frnt. Shaft; Frt.)ⓐ	UJ398
	U-Joint (Rear)ⓑ	UJ399		U-Joint (Rr. Shaft; Rr.)ⓑ	UJ450
1988-1983 Mighty Max w/ 3 Joint Shaft & 2.6L Eng.: [Type 2]				1999 Montero Sport Exc. LTD w/ 3.5L Eng.: [Type 15]	
	U-Joint (Front)ⓐ	UJ399		U-Joint (Frnt. Shaft; Frt.)ⓐ	UJ398
	U-Joint (Center)ⓑ	UJ399		U-Joint (Rr. Shaft; Frt.)ⓑ	UJ450
	U-Joint (Rear)ⓐ	UJ399		U-Joint (Rr. Shaft; Rr.)ⓐ	UJ450
1985-1983 Mighty Max w/ 2.3L Eng.: [Type 2]				1999 Montero Sport LTD w/ 3.5L Eng.: [Type 15]	
	U-Joint (Front)ⓐ	UJ399		U-Joint (Frnt. Shaft; Frt.)ⓐ	UJ399
	U-Joint (Center)ⓑ	UJ399		U-Joint (Rr. Shaft; Frt.)ⓑ	UJ450
	U-Joint (Rear)ⓐ	UJ399		U-Joint (Rr. Shaft; Rr.)ⓐ	UJ450
1985-1983 Mighty Max w/ 2.3L Eng.: [Type 2]				1998-1997 Montero w/ Auto. Trans.: [Type 20]	
	U-Joint (Front)ⓐ	UJ399		U-Joint (Frnt. Shaft; Frt.)ⓐ	UJ399
	U-Joint (Center)ⓑ	UJ399		U-Joint (Frnt. Shaft; Rr.)ⓑ	UJ399
	U-Joint (Rear)ⓐ	UJ399		U-Joint (Rr. Shaft; Rr.)ⓐ	UJ450
1985-1983 Mighty Max w/ 2.3L Eng.: [Type 2]				1998-1997 Montero w/ Man. Trans.: [Type 20]	
	U-Joint (Front)ⓐ	UJ399		U-Joint (Frnt. Shaft; Frt.)ⓐ	UJ399
	U-Joint (Center)ⓑ	UJ399		U-Joint (Frnt. Shaft; Rr.)ⓑ	UJ399
	U-Joint (Rear)ⓐ	UJ399		U-Joint (Rr. Shaft; Rr.)ⓐ	UJ450
1985-1983 Mighty Max w/ 2.3L Eng.: [Type 2]				1998-1997 Montero Sport: [Type 15]	
	U-Joint (Front)ⓐ	UJ399		U-Joint (Frnt. Shaft; Frt.)ⓐ	UJ398
	U-Joint (Center)ⓑ	UJ399		U-Joint (Rr. Shaft; Frt.)ⓑ	UJ450
	U-Joint (Rear)ⓐ	UJ399		U-Joint (Rr. Shaft; Rr.)ⓐ	UJ450
1985-1983 Mighty Max w/ 2.3L Eng.: [Type 2]				1996-1994 Montero w/ 3.0L Eng.: [Type 13]	
	U-Joint (Front)ⓐ	UJ399		U-Joint (Frnt. Shaft; Frt.)ⓐ	UJ398
	U-Joint (Center)ⓑ	UJ399		U-Joint (Frnt. Shaft; Rr.)ⓑ	UJ398
	U-Joint (Rear)ⓐ	UJ399		U-Joint (Rr. Shaft; Frt.)ⓑ	UJ450
1985-1983 Mighty Max w/ 2.3L Eng.: [Type 2]				U-Joint (Rr. Shaft; Rr.)ⓐ	UJ450

(Continued)

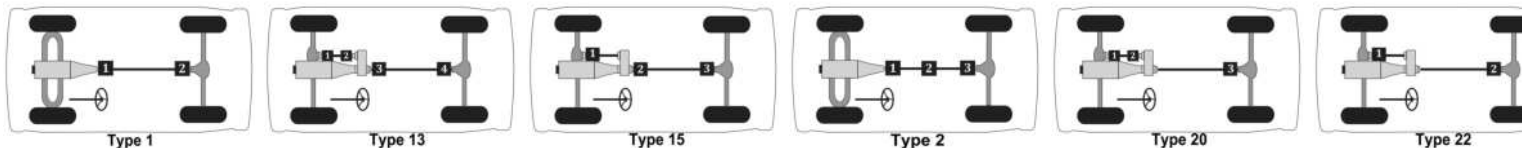

Passenger cars, light & medium trucks

Mitsubishi Truck Mighty Max, Montero, Montero Sport, Raider -- (Cont.)

MFG./YEAR	MODEL & LOCATION	PART NO.	MFG./YEAR	MODEL & LOCATION	PART NO.
Drive Shaft (4 W/D) (Cont.)			Drive Shaft (4 W/D) (Cont.)		
U-Joint (Cont.)			U-Joint (Cont.)		
1996-1994 Montero w/ 3.5L Eng. From 12/2/93:			1989 Montero w/ 2.6L Eng.: [Type 13]		
[Type 13]			U-Joint (Fr. Shaft; Fr.) [⊙] UJ398		
U-Joint (Fr. Shaft; Fr.) [⊙] UJ399			U-Joint (Fr. Shaft; Rr.) [⊙] UJ398		
U-Joint (Fr. Shaft; Rr.) [⊙] UJ399			U-Joint (Rr. Shaft; Fr.) [⊙] UJ399		
U-Joint (Rr. Shaft; Fr.) [⊙] UJ450			U-Joint (Rr. Shaft; Rr.) [⊙] UJ399		
U-Joint (Rr. Shaft; Rr.) [⊙] UJ450			1989 Montero w/ 3.0L Eng.: [Type 13]		
1996-1990 Mighty Max w/ 2 Joint Shaft: [Type 13]			U-Joint (Fr. Shaft; Fr.) [⊙] UJ398		
U-Joint (Fr. Shaft; Fr.) [⊙] UJ398			U-Joint (Fr. Shaft; Rr.) [⊙] UJ398		
U-Joint (Fr. Shaft; Rr.) [⊙] UJ398			U-Joint (Rr. Shaft; Fr.) [⊙] UJ450		
U-Joint (Rr. Shaft; Fr.) [⊙] UJ450			U-Joint (Rr. Shaft; Rr.) [⊙] UJ450		
U-Joint (Rr. Shaft; Rr.) [⊙] UJ450			1989-1983 Mighty Max: [Type 13]		
1996-1990 Mighty Max w/ 3 Joint Shaft: [Type 14]			U-Joint (Fr. Shaft; Fr.) [⊙] UJ398		
U-Joint (Fr. Shaft; Fr.) [⊙] UJ398			U-Joint (Fr. Shaft; Rr.) [⊙] UJ398		
U-Joint (Fr. Shaft; Rr.) [⊙] UJ398			U-Joint (Rr. Shaft; Fr.) [⊙] UJ399		
U-Joint (Rr. Shaft; Fr.) [⊙] UJ450			U-Joint (Rr. Shaft; Rr.) [⊙] UJ399		
U-Joint (Rr. Shaft; Ctr.) [⊙] UJ450			1988-1983 Montero: [Type 13]		
U-Joint (Rr. Shaft; Rr.) [⊙] UJ450			U-Joint (Fr. Shaft; Fr.) [⊙] UJ398		
1994 Montero w/ 3.5L Eng. Thru 12/1/93:			U-Joint (Fr. Shaft; Rr.) [⊙] UJ398		
[Type 13]			U-Joint (Rr. Shaft; Fr.) [⊙] UJ399		
U-Joint (Fr. Shaft; Fr.) [⊙] UJ399			U-Joint (Rr. Shaft; Rr.) [⊙] UJ399		
U-Joint (Fr. Shaft; Rr.) [⊙] UJ399					
1993-1990 Montero: [Type 13]					
U-Joint (Fr. Shaft; Fr.) [⊙] UJ398					
U-Joint (Fr. Shaft; Rr.) [⊙] UJ398					
U-Joint (Rr. Shaft; Fr.) [⊙] UJ450					
U-Joint (Rr. Shaft; Rr.) [⊙] UJ450					

Nissan Truck US & Canada

<p>Drive Shaft (2 W/D)</p> <p>U-Joint</p> <p>2019-2016 NV2500 & NV3500: [Type 2]</p> <p>U-Joint (Front)[⊙] UJ330A</p> <p>Brute Force Greaseable UJ295A</p> <p>U-Joint (Center)[⊙] UJ330A</p> <p>Brute Force Greaseable UJ295A</p> <p>U-Joint (Rear)[⊙] UJ330A</p> <p>Brute Force Greaseable UJ295A</p> <p>2019-2012 NV1500: [Type 2]</p> <p>U-Joint (Front)[⊙] UJ331A</p> <p>Brute Force Greaseable UJ232A</p> <p>U-Joint (Center)[⊙] UJ331A</p> <p>Brute Force Greaseable UJ232A</p> <p>U-Joint (Rear)[⊙] UJ331A</p> <p>Brute Force Greaseable UJ232A</p>	<p>Drive Shaft (2 W/D) (Cont.)</p> <p>U-Joint (Cont.)</p> <p>2019-2005 Frontier w/ 4 Cyl. Eng.: [Type 2]</p> <p>U-Joint (Front)[⊙] UJ369</p> <p>Brute Force Greaseable UJ280</p> <p>Brute Force Non Greaseable UJ269</p> <p>(For Aluminum Drive Shaft) UJ369C</p> <p>U-Joint (Center)[⊙] UJ369</p> <p>Brute Force Greaseable UJ280</p> <p>Brute Force Non Greaseable UJ269</p> <p>(For Aluminum Drive Shaft) UJ369C</p> <p>U-Joint (Rear)[⊙] UJ369</p> <p>Brute Force Greaseable UJ280</p> <p>Brute Force Non Greaseable UJ269</p> <p>(For Aluminum Drive Shaft) UJ369C</p> <p style="text-align: right;">(Continued)</p>
--	--

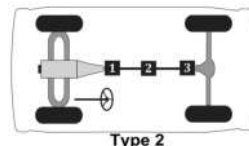
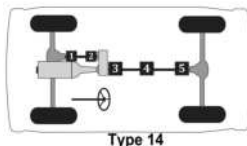
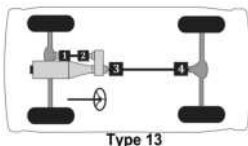

530 ▲ For Use w/ 1.063" Bearing Cap Application. ⊙ For Use w/ 1.188" Bearing Cap Application. ◇ For Use w/ Inner Lock Ring Application on Half Shaft. □ For Use w/ Outer Lock Ring Application on Half Shaft.

Passenger cars, light & medium trucks

(Cont.) -- Nissan Truck US & Canada

MFG./YEAR	MODEL & LOCATION	PART NO.	MFG./YEAR	MODEL & LOCATION	PART NO.
Drive Shaft (2 W/D) (Cont.)			Drive Shaft (2 W/D) (Cont.)		
U-Joint (Cont.)			U-Joint (Cont.)		
2019-2005 Frontier w/ 6 Cyl. Eng.: [Type 2]			2015-2005 Xterra: [Type 1]		
	U-Joint (Front)Ⓢ	UJ354		U-Joint (Front)Ⓢ	UJ354
	Brute Force Greaseable	UJ270		Brute Force Greaseable	UJ270
	Brute Force Non Greaseable	UJ254		Brute Force Non Greaseable	UJ254
	(For Aluminum Drive Shaft)	UJ354C		(For Aluminum Drive Shaft)	UJ354C
	U-Joint (Center)Ⓢ	UJ354		U-Joint (Rear)Ⓢ	UJ354
	Brute Force Greaseable	UJ270		Brute Force Greaseable	UJ270
	Brute Force Non Greaseable	UJ254		Brute Force Non Greaseable	UJ254
	(For Aluminum Drive Shaft)	UJ354C		(For Aluminum Drive Shaft)	UJ354C
	U-Joint (Rear)Ⓢ	UJ354		2012 Pathfinder: [Type 1]	
	Brute Force Greaseable	UJ270		U-Joint (Front)Ⓢ	UJ354
	Brute Force Non Greaseable	UJ254		Brute Force Greaseable	UJ270
	(For Aluminum Drive Shaft)	UJ354C		Brute Force Non Greaseable	UJ254
	2015-2012 NV2500 & NV3500 w/ 4.0L Eng.:			(For Aluminum Drive Shaft)	UJ354C
	[Type 2]			U-Joint (Rear)Ⓢ	UJ354
	U-Joint (Front)Ⓢ	UJ331A		Brute Force Greaseable	UJ270
	Brute Force Greaseable	UJ232A		Brute Force Non Greaseable	UJ254
	U-Joint (Center)Ⓢ	UJ331A		(For Aluminum Drive Shaft)	UJ354C
	Brute Force Greaseable	UJ232A		2011-2009 Pathfinder: [Type 1]	
	U-Joint (Rear)Ⓢ	UJ331A		U-Joint (Front)Ⓢ	UJ331
	Brute Force Greaseable	UJ232A		Brute Force Greaseable	UJ232
	2015-2012 NV2500 & NV3500 w/ 5.6L Eng.:			Brute Force Non Greaseable	UJ231
	[Type 2]			(For Aluminum Drive Shaft)	UJ331C
	U-Joint (Front)Ⓢ	UJ330A		U-Joint (Rear)Ⓢ	UJ331
	Brute Force Greaseable	UJ295A		Brute Force Greaseable	UJ232
	U-Joint (Center)Ⓢ	UJ330A		Brute Force Non Greaseable	UJ231
	Brute Force Greaseable	UJ295A		(For Aluminum Drive Shaft)	UJ331C
	U-Joint (Rear)Ⓢ	UJ330A		2008-2005 Pathfinder: [Type 1]	
	Brute Force Greaseable	UJ295A		U-Joint (Front)Ⓢ	UJ354
	2015-2007 Titan: [Type 2]			Brute Force Greaseable	UJ270
	U-Joint (Front)Ⓢ	UJ330		Brute Force Non Greaseable	UJ254
	Brute Force Greaseable	UJ295		(For Aluminum Drive Shaft)	UJ354C
	(For Aluminum Drive Shaft)	UJ330C		U-Joint (Rear)Ⓢ	UJ354
	U-Joint (Center)Ⓢ	UJ330		Brute Force Greaseable	UJ270
	Brute Force Greaseable	UJ295		Brute Force Non Greaseable	UJ254
	(For Aluminum Drive Shaft)	UJ330C		(For Aluminum Drive Shaft)	UJ354C
	U-Joint (Rear)Ⓢ	UJ330		2006-2004 Titan: [Type 2]	
	Brute Force Greaseable	UJ295		U-Joint (Front)Ⓢ	UJ331
	(For Aluminum Drive Shaft)	UJ330C		Brute Force Greaseable	UJ232
	2015-2005 Armada: [Type 1]			Brute Force Non Greaseable	UJ231
	U-Joint (Front)Ⓢ	UJ331		(For Aluminum Drive Shaft)	UJ331C
	Brute Force Greaseable	UJ232		U-Joint (Center)Ⓢ	UJ331
	Brute Force Non Greaseable	UJ231		Brute Force Greaseable	UJ232
	(For Aluminum Drive Shaft)	UJ331C		Brute Force Non Greaseable	UJ231
	U-Joint (Rear)Ⓢ	UJ331		(For Aluminum Drive Shaft)	UJ331C
	Brute Force Greaseable	UJ232		U-Joint (Rear)Ⓢ	UJ331
	Brute Force Non Greaseable	UJ231		Brute Force Greaseable	UJ232
	(For Aluminum Drive Shaft)	UJ331C		Brute Force Non Greaseable	UJ231
				(For Aluminum Drive Shaft)	UJ331C

(Continued)

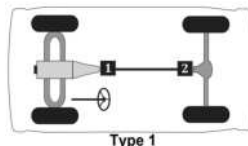

Type 1

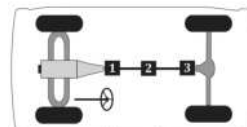

Type 2

Passenger cars, light & medium trucks

Nissan Truck US & Canada -- (Cont.)

MFG./YEAR	MODEL & LOCATION	PART NO.	MFG./YEAR	MODEL & LOCATION	PART NO.
Drive Shaft (2 W/D) (Cont.)			Drive Shaft (2 W/D) (Cont.)		
U-Joint (Cont.)			U-Joint (Cont.)		
2004 Pathfinder Armada: [Type 1]			1994-1986 Pickup w/ 2 Joint Shaft: [Type 1]		
U-Joint (Front)Ⓛ		UJ331	U-Joint (Front)Ⓛ		UJ369
Brute Force Greaseable		UJ232	Brute Force Greaseable		UJ280
Brute Force Non Greaseable		UJ231	Brute Force Non Greaseable		UJ269
(For Aluminum Drive Shaft)		UJ331C	(For Aluminum Drive Shaft)		UJ369C
U-Joint (Rear)Ⓢ		UJ331	U-Joint (Rear)Ⓢ		UJ369
Brute Force Greaseable		UJ232	Brute Force Greaseable		UJ280
Brute Force Non Greaseable		UJ231	Brute Force Non Greaseable		UJ269
(For Aluminum Drive Shaft)		UJ331C	(For Aluminum Drive Shaft)		UJ369C
2004-2002 Frontier w/ 2 Joint Shaft: [Type 1]			1985-1965 520, 521, 620 & 720 w/ 2 Joint Shaft:		
U-Joint (Front)Ⓛ		UJ369	[Type 1]		
Brute Force Greaseable		UJ280	U-Joint (Front)Ⓛ		UJ391
Brute Force Non Greaseable		UJ269	U-Joint (Rear)Ⓢ		UJ391
(For Aluminum Drive Shaft)		UJ369C	1985-1965 520, 521, 620 & 720 w/ 3 Joint Shaft:		
U-Joint (Rear)Ⓢ		UJ369	[Type 2]		
Brute Force Greaseable		UJ280	U-Joint (Front)Ⓛ		UJ391
Brute Force Non Greaseable		UJ269	U-Joint (Center)Ⓢ		UJ391
(For Aluminum Drive Shaft)		UJ369C	U-Joint (Rear)Ⓢ		UJ391
2004-2002 Frontier w/ 3 Joint Shaft: [Type 2]			Drive Shaft (4 W/D)		
U-Joint (Front)Ⓛ		UJ369	U-Joint		
Brute Force Greaseable		UJ280	2019-2016 Titan XD:		
Brute Force Non Greaseable		UJ269	U-Joint (Fr. Shaft; Fr.)		UJ270
(For Aluminum Drive Shaft)		UJ369C	U-Joint (Fr. Shaft; Rr.)		UJ270
U-Joint (Center)Ⓢ		UJ369	U-Joint (Rr. Shaft; Fr.)		UJ270
Brute Force Greaseable		UJ280	U-Joint (Rr. Shaft; Rr.)		UJ270
Brute Force Non Greaseable		UJ269	2019-2005 Frontier & Xterra: [Type 13]		
(For Aluminum Drive Shaft)		UJ369C	U-Joint (Fr. Shaft; Fr.)Ⓛ		UJ369
U-Joint (Rear)Ⓢ		UJ369	Brute Force Greaseable		UJ280
Brute Force Greaseable		UJ280	Brute Force Non Greaseable		UJ269
Brute Force Non Greaseable		UJ269	(For Aluminum Drive Shaft)		UJ369C
(For Aluminum Drive Shaft)		UJ369C	U-Joint (Fr. Shaft; Rr.)Ⓢ		UJ369
2004-2001 Pathfinder: [Type 1]			Brute Force Greaseable		UJ280
U-Joint (Front)Ⓛ		UJ393	Brute Force Non Greaseable		UJ269
U-Joint (Rear)Ⓢ		UJ393	(For Aluminum Drive Shaft)		UJ369C
2000-1989 Pathfinder: [Type 2]			U-Joint (Rr. Shaft; Fr.)Ⓢ		UJ354
U-Joint (Front)Ⓛ		UJ399	Brute Force Greaseable		UJ270
U-Joint (Center)Ⓢ		UJ399	Brute Force Non Greaseable		UJ254
U-Joint (Rear)Ⓢ		UJ399	(For Aluminum Drive Shaft)		UJ354C
1997-1986 Pickup w/ 3 Joint Shaft: [Type 2]			U-Joint (Rr. Shaft; Rr.)Ⓢ		UJ354
U-Joint (Front)Ⓛ		UJ369	Brute Force Greaseable		UJ270
Brute Force Greaseable		UJ280	Brute Force Non Greaseable		UJ254
Brute Force Non Greaseable		UJ269	(For Aluminum Drive Shaft)		UJ354C
(For Aluminum Drive Shaft)		UJ369C	(Continued)		
U-Joint (Center)Ⓢ		UJ369			
Brute Force Greaseable		UJ280			
Brute Force Non Greaseable		UJ269			
(For Aluminum Drive Shaft)		UJ369C			
Clamp Kit (Center)		UJ437-10			
U-Joint (Rear)Ⓢ		UJ369			
Brute Force Greaseable		UJ280			
Brute Force Non Greaseable		UJ269			
(For Aluminum Drive Shaft)		UJ369C			

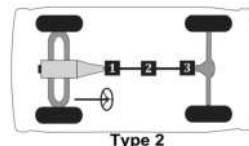
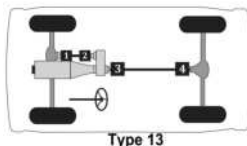
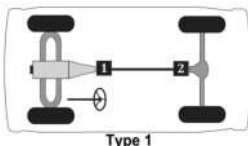

MFG./YEAR	MODEL & LOCATION	PART NO.	MFG./YEAR	MODEL & LOCATION	PART NO.
Drive Shaft (4 W/D) (Cont.)			Drive Shaft (4 W/D) (Cont.)		
U-Joint (Cont.)			U-Joint (Cont.)		
2015-2007 Armada & Titan: [Type 13]			2008-2005 Pathfinder: [Type 13]		
	U-Joint (Frnt. Shaft; Frnt.)❶	UJ369		U-Joint (Frnt. Shaft; Frnt.)❶	UJ369
	Brute Force Greaseable	UJ280		Brute Force Greaseable	UJ280
	Brute Force Non Greaseable	UJ269		Brute Force Non Greaseable	UJ269
	(For Aluminum Drive Shaft)	UJ369C		(For Aluminum Drive Shaft)	UJ369C
	U-Joint (Rr. Shaft; Rr.)❷	UJ369		U-Joint (Frnt. Shaft; Rr.)❷	UJ369
	Brute Force Greaseable	UJ280		Brute Force Greaseable	UJ280
	Brute Force Non Greaseable	UJ269		Brute Force Non Greaseable	UJ269
	(For Aluminum Drive Shaft)	UJ369C		(For Aluminum Drive Shaft)	UJ369C
	U-Joint (Rr. Shaft; Frnt.)❸	UJ330		U-Joint (Rr. Shaft; Frnt.)❸	UJ354
	Brute Force Greaseable	UJ295		Brute Force Greaseable	UJ270
	(For Aluminum Drive Shaft)	UJ330C		Brute Force Non Greaseable	UJ254
	U-Joint (Rr. Shaft; Rr.)❹	UJ330		(For Aluminum Drive Shaft)	UJ354C
	Brute Force Greaseable	UJ295		U-Joint (Rr. Shaft; Rr.)❹	UJ354
	(For Aluminum Drive Shaft)	UJ330C		Brute Force Greaseable	UJ270
				Brute Force Non Greaseable	UJ254
				(For Aluminum Drive Shaft)	UJ354C
				2006-2005 Armada: [Type 13]	
				U-Joint (Frnt. Shaft; Frnt.)❶	UJ369
				Brute Force Greaseable	UJ280
				Brute Force Non Greaseable	UJ269
				(For Aluminum Drive Shaft)	UJ369C
				U-Joint (Frnt. Shaft; Rr.)❷	UJ369
				Brute Force Greaseable	UJ280
				Brute Force Non Greaseable	UJ269
				(For Aluminum Drive Shaft)	UJ369C
				U-Joint (Rr. Shaft; Frnt.)❸	UJ331
				Brute Force Greaseable	UJ232
				Brute Force Non Greaseable	UJ231
				(For Aluminum Drive Shaft)	UJ331C
				U-Joint (Rr. Shaft; Rr.)❹	UJ331
				Brute Force Greaseable	UJ232
				Brute Force Non Greaseable	UJ231
				(For Aluminum Drive Shaft)	UJ331C
				2006-2004 Titan: [Type 13]	
				U-Joint (Frnt. Shaft; Frnt.)❶	UJ369
				Brute Force Greaseable	UJ280
				Brute Force Non Greaseable	UJ269
				(For Aluminum Drive Shaft)	UJ369C
				U-Joint (Frnt. Shaft; Rr.)❷	UJ369
				Brute Force Greaseable	UJ280
				Brute Force Non Greaseable	UJ269
				(For Aluminum Drive Shaft)	UJ369C
				U-Joint (Rr. Shaft; Frnt.)❸	UJ331
				Brute Force Greaseable	UJ232
				Brute Force Non Greaseable	UJ231
				(For Aluminum Drive Shaft)	UJ331C
				U-Joint (Rr. Shaft; Rr.)❹	UJ331
				Brute Force Greaseable	UJ232
				Brute Force Non Greaseable	UJ231
				(For Aluminum Drive Shaft)	UJ331C

(Continued)

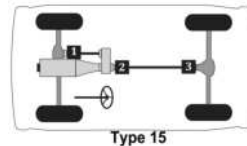
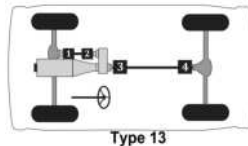

Nissan Truck US & Canada -- (Cont.)

MFG./YEAR	MODEL & LOCATION	PART NO.	MFG./YEAR	MODEL & LOCATION	PART NO.
Drive Shaft (4 W/D) (Cont.)			Drive Shaft (4 W/D) (Cont.)		
U-Joint (Cont.)			U-Joint (Cont.)		
2004 Pathfinder Armada: [Type 13]			2004-1998 Frontier w/ 3 Joint Rear Shaft: [Type 14]		
U-Joint (Fr. Shaft; Fr.) [⊙]		UJ369	U-Joint (Fr. Shaft; Fr.) [⊙]		UJ369
Brute Force Greaseable		UJ280	Brute Force Greaseable		UJ280
Brute Force Non Greaseable		UJ269	Brute Force Non Greaseable		UJ269
(For Aluminum Drive Shaft)		UJ369C	(For Aluminum Drive Shaft)		UJ369C
U-Joint (Fr. Shaft; Rr.) [⊙]		UJ369	U-Joint (Fr. Shaft; Rr.) [⊙]		UJ369
Brute Force Greaseable		UJ280	Brute Force Greaseable		UJ280
Brute Force Non Greaseable		UJ269	Brute Force Non Greaseable		UJ269
(For Aluminum Drive Shaft)		UJ369C	(For Aluminum Drive Shaft)		UJ369C
U-Joint (Rr. Shaft; Fr.) [⊙]		UJ331	U-Joint (Rr. Shaft; Fr.) [⊙]		UJ369
Brute Force Greaseable		UJ232	Brute Force Greaseable		UJ280
Brute Force Non Greaseable		UJ231	Brute Force Non Greaseable		UJ269
(For Aluminum Drive Shaft)		UJ331C	(For Aluminum Drive Shaft)		UJ369C
U-Joint (Rr. Shaft; Rr.) [⊙]		UJ331	U-Joint (Rr. Shaft; Rr.) [⊙]		UJ369
Brute Force Greaseable		UJ232	Brute Force Greaseable		UJ280
Brute Force Non Greaseable		UJ231	Brute Force Non Greaseable		UJ269
(For Aluminum Drive Shaft)		UJ331C	(For Aluminum Drive Shaft)		UJ369C
2004-1998 Frontier w/ 2 Joint Rear Shaft: [Type 13]			2004-1990 Pathfinder w/ Rear Shaft Inner Lock		
U-Joint (Fr. Shaft; Fr.) [⊙]		UJ369	Rings: [Type 13]		
Brute Force Greaseable		UJ280	U-Joint (Fr. Shaft; Fr.) [⊙]		UJ446
Brute Force Non Greaseable		UJ269	U-Joint (Fr. Shaft; Rr.) [⊙]		UJ446
(For Aluminum Drive Shaft)		UJ369C	U-Joint (Rr. Shaft; Fr.) [⊙]		UJ393
U-Joint (Fr. Shaft; Rr.) [⊙]		UJ369	U-Joint (Rr. Shaft; Rr.) [⊙]		UJ393
Brute Force Greaseable		UJ280	2004-1990 Pathfinder w/ Rear Shaft Outer Lock		
Brute Force Non Greaseable		UJ269	Rings: [Type 13]		
(For Aluminum Drive Shaft)		UJ369C	U-Joint (Fr. Shaft; Fr.) [⊙]		UJ446
U-Joint (Rr. Shaft; Fr.) [⊙]		UJ369	U-Joint (Fr. Shaft; Rr.) [⊙]		UJ446
Brute Force Greaseable		UJ280	U-Joint (Rr. Shaft; Fr.) [⊙]		UJ369
Brute Force Non Greaseable		UJ269	Brute Force Greaseable		UJ280
(For Aluminum Drive Shaft)		UJ369C	Brute Force Non Greaseable		UJ269
U-Joint (Rr. Shaft; Rr.) [⊙]		UJ369	(For Aluminum Drive Shaft)		UJ369C
Brute Force Greaseable		UJ280	U-Joint (Rr. Shaft; Rr.) [⊙]		UJ369
Brute Force Non Greaseable		UJ269	Brute Force Greaseable		UJ280
(For Aluminum Drive Shaft)		UJ369C	Brute Force Non Greaseable		UJ269
			(For Aluminum Drive Shaft)		UJ369C

(Continued)

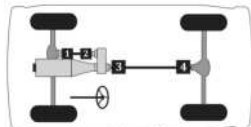

Type 13

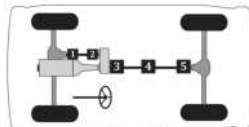

Type 14

534 ▲ For Use w/ 1.063" Bearing Cap Application. ⊙ For Use w/ 1.188" Bearing Cap Application. ◇ For Use w/ Inner Lock Ring Application on Half Shaft. □ For Use w/ Outer Lock Ring Application on Half Shaft.

Passenger cars, light & medium trucks

(Cont.) -- Nissan Truck US & Canada

MFG./YEAR	MODEL & LOCATION	PART NO.	MFG./YEAR	MODEL & LOCATION	PART NO.
Drive Shaft (4 W/D) (Cont.)			Drive Shaft (4 W/D) (Cont.)		
U-Joint (Cont.)			U-Joint (Cont.)		
1997-1986 Pickup American Built w/ 2 Joint			1989-1988 Pickup Japan Built w/ 2 Joint Shaft &		
Shaft: [Type 13]			6 Cyl. Eng.: [Type 13]		
U-Joint (Frnt. Shaft; Frnt.) ^①		UJ369	U-Joint (Frnt. Shaft; Frnt.) ^①		UJ446
Brute Force Greaseable		UJ280	U-Joint (Frnt. Shaft; Rr.) ^②		UJ446
Brute Force Non Greaseable		UJ269	U-Joint (Rr. Shaft; Frnt.) ^③		UJ393
(For Aluminum Drive Shaft)		UJ369C	U-Joint (Rr. Shaft; Rr.) ^④		UJ393
U-Joint (Frnt. Shaft; Rr.) ^②		UJ369	1989-1988 Pickup Japan Built w/ 3 Joint Shaft &		
Brute Force Greaseable		UJ280	6 Cyl. Eng.: [Type 14]		
Brute Force Non Greaseable		UJ269	U-Joint (Frnt. Shaft; Frnt.) ^①		UJ446
(For Aluminum Drive Shaft)		UJ369C	U-Joint (Frnt. Shaft; Rr.) ^②		UJ446
U-Joint (Rr. Shaft; Frnt.) ^③		UJ369	U-Joint (Rr. Shaft; Frnt.) ^③		UJ393
Brute Force Greaseable		UJ280	U-Joint (Rr. Shaft; Ctr.) ^④		UJ393
Brute Force Non Greaseable		UJ269	U-Joint (Rr. Shaft; Rr.) ^④		UJ393
(For Aluminum Drive Shaft)		UJ369C	1989-1987 Pathfinder: [Type 13]		
U-Joint (Rr. Shaft; Rr.) ^④		UJ369	U-Joint (Frnt. Shaft; Frnt.) ^①		UJ446
Brute Force Greaseable		UJ280	U-Joint (Frnt. Shaft; Rr.) ^②		UJ446
Brute Force Non Greaseable		UJ269	U-Joint (Rr. Shaft; Frnt.) ^③		UJ393
(For Aluminum Drive Shaft)		UJ369C	U-Joint (Rr. Shaft; Rr.) ^④		UJ393
1997-1986 Pickup American Built w/ 3 Joint			1987-1986 Pickup Japan Built w/ 2 Joint Shaft:		
Shaft: [Type 14]			[Type 13]		
U-Joint (Frnt. Shaft; Frnt.) ^①		UJ369	U-Joint (Frnt. Shaft; Frnt.) ^①		UJ446
Brute Force Greaseable		UJ280	U-Joint (Frnt. Shaft; Rr.) ^②		UJ446
Brute Force Non Greaseable		UJ269	U-Joint (Rr. Shaft; Frnt.) ^③		UJ393
(For Aluminum Drive Shaft)		UJ369C	U-Joint (Rr. Shaft; Rr.) ^④		UJ393
U-Joint (Frnt. Shaft; Rr.) ^②		UJ369	1987-1986 Pickup Japan Built w/ 3 Joint Shaft:		
Brute Force Greaseable		UJ280	[Type 14]		
Brute Force Non Greaseable		UJ269	U-Joint (Frnt. Shaft; Frnt.) ^①		UJ446
(For Aluminum Drive Shaft)		UJ369C	U-Joint (Frnt. Shaft; Rr.) ^②		UJ446
U-Joint (Rr. Shaft; Frnt.) ^③		UJ369	U-Joint (Rr. Shaft; Frnt.) ^③		UJ393
Brute Force Greaseable		UJ280	U-Joint (Rr. Shaft; Ctr.) ^④		UJ393
Brute Force Non Greaseable		UJ269	U-Joint (Rr. Shaft; Rr.) ^④		UJ393
(For Aluminum Drive Shaft)		UJ369C	1986-1983 720 Pickup: [Type 25]		
U-Joint (Rr. Shaft; Rr.) ^④		UJ369	U-Joint (Frnt. Shaft; Frnt.) ^①		UJ393
Brute Force Greaseable		UJ280	U-Joint (Frnt. Shaft; Rr.) ^②		UJ393
Brute Force Non Greaseable		UJ269	U-Joint (Intmd. Shaft; Frnt.) ^⑤		UJ393
(For Aluminum Drive Shaft)		UJ369C	U-Joint (Intmd. Shaft; Rr.) ^⑥		UJ393
U-Joint (Rr. Shaft; Frnt.) ^③		UJ369	U-Joint (Rr. Shaft; Frnt.) ^③		UJ393
Brute Force Greaseable		UJ280	U-Joint (Rr. Shaft; Rr.) ^④		UJ393
Brute Force Non Greaseable		UJ269	1982-1980 720 Pickup: [Type 25]		
(For Aluminum Drive Shaft)		UJ369C	U-Joint (Frnt. Shaft; Frnt.) ^①		UJ391
1989-1988 Pickup Japan Built w/ 2 Joint Shaft &			U-Joint (Frnt. Shaft; Rr.) ^②		UJ391
4 Cyl. Eng.: [Type 13]			U-Joint (Intmd. Shaft; Frnt.) ^⑤		UJ391
U-Joint (Frnt. Shaft; Frnt.) ^①		UJ391	U-Joint (Intmd. Shaft; Rr.) ^⑥		UJ391
U-Joint (Frnt. Shaft; Rr.) ^②		UJ391	U-Joint (Rr. Shaft; Frnt.) ^③		UJ391
U-Joint (Rr. Shaft; Frnt.) ^③		UJ446	U-Joint (Rr. Shaft; Rr.) ^④		UJ391
U-Joint (Rr. Shaft; Rr.) ^④		UJ446			
1989-1988 Pickup Japan Built w/ 3 Joint Shaft &					
4 Cyl. Eng.: [Type 14]					
U-Joint (Frnt. Shaft; Frnt.) ^①		UJ391			
U-Joint (Frnt. Shaft; Rr.) ^②		UJ391			
U-Joint (Rr. Shaft; Frnt.) ^③		UJ446			
U-Joint (Rr. Shaft; Ctr.) ^④		UJ446			
U-Joint (Rr. Shaft; Rr.) ^④		UJ446			

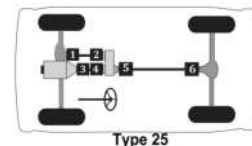
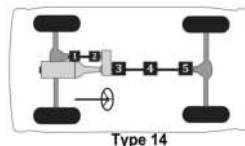
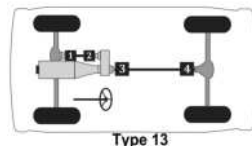

Passenger cars, light & medium trucks

Oldsmobile Truck Bravada

MFG./YEAR	MODEL & LOCATION	PART NO.	MFG./YEAR	MODEL & LOCATION	PART NO.
Drive Shaft (2 W/D)			Drive Shaft (AWD) (Cont.)		
U-Joint			U-Joint (Cont.)		
2004-2002 All: [Type 1]			1994-1991 w/ 2.75" Front Shaft Yoke: [Type 21]		
	U-Joint (Front)❶	UJ534G		U-Joint (Fr. Shaft; Rr.)❶ [2]	UJ437G
	Brute Force Greaseable	UJ235		Brute Force Greaseable	UJ240
	Brute Force Non Greaseable	UJ234		Brute Force Non Greaseable	UJ237
	Clamp Kit (Front)	UJ530-10		Clamp Kit (Fr. Shaft; Rr.)	UJ437-10
	U-Joint (Rear)❷	UJ534G		U-Joint (Rr. Shaft; Frt.)❷	UJ534G
	Brute Force Greaseable	UJ235		Brute Force Greaseable	UJ235
	Brute Force Non Greaseable	UJ234		Brute Force Non Greaseable	UJ234
	Clamp Kit (Rear)	UJ530-10		Clamp Kit (Rr. Shaft; Frt.)	UJ530-10
Drive Shaft (AWD)				U-Joint (Rr. Shaft; Rr.)❸	UJ534G
U-Joint				Brute Force Greaseable	UJ235
2004-1998 All: [Type 15]				Brute Force Non Greaseable	UJ234
	U-Joint (Fr. Shaft; Frt.)❶	UJ445		Clamp Kit (Rr. Shaft; Rr.)	UJ530-10
	Brute Force Greaseable	UJ225		1994-1991 w/ 3.5" Front Shaft Yoke: [Type 21]	
	Clamp Kit (Fr. Shaft; Frt.)	UJ360-10		U-Joint (Fr. Shaft; Rr.)❶ [2]	UJ379
	U-Joint (Rr. Shaft; Frt.)❷	UJ534G		Brute Force Greaseable	UJ280
	Brute Force Greaseable	UJ235		Brute Force Non Greaseable	UJ269
	Brute Force Non Greaseable	UJ234		U-Joint (Rr. Shaft; Frt.)❷	UJ534G
	Clamp Kit (Rr. Shaft; Frt.)	UJ530-10		Brute Force Greaseable	UJ235
	U-Joint (Rr. Shaft; Rr.)❸	UJ534G		Brute Force Non Greaseable	UJ234
	Brute Force Greaseable	UJ235		Clamp Kit (Rr. Shaft; Frt.)	UJ530-10
	Brute Force Non Greaseable	UJ234		U-Joint (Rr. Shaft; Rr.)❸	UJ534G
	Clamp Kit (Rr. Shaft; Rr.)	UJ530-10		Brute Force Greaseable	UJ235
	1997-1996 All: [Type 21]			Brute Force Non Greaseable	UJ234
	U-Joint (Fr. Shaft; Rr.)❶ [2]	UJ534G		Clamp Kit (Rr. Shaft; Rr.)	UJ530-10
	Brute Force Greaseable	UJ235			
	Brute Force Non Greaseable	UJ234			
	Clamp Kit (Fr. Shaft; Rr.)	UJ530-10			
	U-Joint (Rr. Shaft; Frt.)❷	UJ534G			
	Brute Force Greaseable	UJ235			
	Brute Force Non Greaseable	UJ234			
	Clamp Kit (Rr. Shaft; Frt.)	UJ530-10			
	U-Joint (Rr. Shaft; Rr.)❸	UJ534G			
	Brute Force Greaseable	UJ235			
	Brute Force Non Greaseable	UJ234			
	Clamp Kit (Rr. Shaft; Rr.)	UJ530-10			
	Ball Seat Repair Kit	UJ606			
	Flange Yoke	UJ626			
	H Yoke	UJ646			

Plymouth Truck Arrow Pickup

Drive Shaft (2 W/D)	
U-Joint	
1982-1979 2.0L Eng.: [Type 1]	
U-Joint (Front)❶	UJ398
U-Joint (Rear)❷	UJ398
1982-1979 2.6L Eng.: [Type 1]	
U-Joint (Front)❶	UJ399
U-Joint (Rear)❷	UJ399

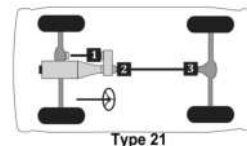
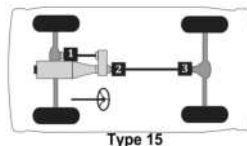
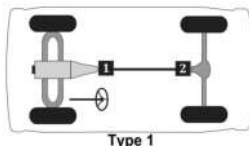

MFG./YEAR	MODEL & LOCATION	PART NO.	MFG./YEAR	MODEL & LOCATION	PART NO.
-----------	------------------	----------	-----------	------------------	----------

Drive Shaft (2 W/D)

U-Joint

1981-1975 w/ 2.125" Yoke: [Type 1]

U-Joint (Front)❶	UJ315G
Brute Force Greaseable	UJ246
Clamp Kit (Front)	UJ318-10
U-Joint (Rear)❷	UJ315G
Brute Force Greaseable	UJ246
Clamp Kit (Rear)	UJ318-10
1981-1975 w/ 2.625" Yoke: [Type 1]		
U-Joint (Front)❶	UJ316
Brute Force Greaseable	UJ248
Clamp Kit (Front)	UJ316-10
U-Joint (Rear)❷	UJ316
Brute Force Greaseable	UJ248
Clamp Kit (Rear)	UJ316-10

Drive Shaft (4 W/D)

U-Joint

1981-1977 w/ 2.125" Rear Shaft Yoke: [Type 26]

U-Joint (Frnt. Shaft; Frt.)❶	UJ315G
Brute Force Greaseable	UJ246
Clamp Kit (Frnt. Shaft; Frt.)	UJ318-10
U-Joint (Frnt. Shaft; Rr.)❷ [2]	UJ534G
Brute Force Greaseable	UJ235
Brute Force Non Greaseable	UJ234
U-Joint (Rr. Shaft; Frt.)❸	UJ315G
Brute Force Greaseable	UJ246
Clamp Kit (Rr. Shaft; Frt.)	UJ318-10
U-Joint (Rr. Shaft; Rr.)❹	UJ315G
Brute Force Greaseable	UJ246
Clamp Kit (Rr. Shaft; Rr.)	UJ318-10
U-Joint (Wheel Joint)❺ [2]	UJ371
Brute Force Greaseable	UJ377
Brute Force Non Greaseable	UJ371
Ball Seat Repair Kit	UJ606
Flange Yoke	UJ626
H Yoke	UJ646

Drive Shaft (4 W/D) (Cont.)

U-Joint (Cont.)

1981-1977 w/ 2.625" Rear Shaft Yoke: [Type 26]

U-Joint (Frnt. Shaft; Frt.)❶	UJ315G
Brute Force Greaseable	UJ246
Clamp Kit (Frnt. Shaft; Frt.)	UJ318-10
U-Joint (Frnt. Shaft; Rr.)❷ [2]	UJ534G
Brute Force Greaseable	UJ235
Brute Force Non Greaseable	UJ234
U-Joint (Rr. Shaft; Frt.)❸	UJ315G
Brute Force Greaseable	UJ246
Clamp Kit (Rr. Shaft; Frt.)	UJ318-10
U-Joint (Rr. Shaft; Rr.)❹	UJ316
Brute Force Greaseable	UJ248
Clamp Kit (Rr. Shaft; Rr.)	UJ316-10
U-Joint (Wheel Joint)❺ [2]	UJ371
Brute Force Greaseable	UJ377
Brute Force Non Greaseable	UJ371
Ball Seat Repair Kit	UJ606
Flange Yoke	UJ626
H Yoke	UJ646
1976-1974 w/ Frnt. Shaft Inner Lock Rings & 2.125" Rear Shaft Yoke: [Type 26]		
U-Joint (Frnt. Shaft; Frt.)❶	UJ315G
Brute Force Greaseable	UJ246
Clamp Kit (Frnt. Shaft; Frt.)	UJ318-10
U-Joint (Frnt. Shaft; Rr.)❷ [2]	UJ534G
Brute Force Greaseable	UJ235
Brute Force Non Greaseable	UJ234
U-Joint (Rr. Shaft; Frt.)❸	UJ315G
Brute Force Greaseable	UJ246
Clamp Kit (Rr. Shaft; Frt.)	UJ318-10
U-Joint (Rr. Shaft; Rr.)❹	UJ315G
Brute Force Greaseable	UJ246
Clamp Kit (Rr. Shaft; Rr.)	UJ318-10
U-Joint (Wheel Joint)❺ [2]	UJ371
Brute Force Greaseable	UJ377
Brute Force Non Greaseable	UJ371
Ball Seat Repair Kit	UJ606
Flange Yoke	UJ626
H Yoke	UJ646

(Continued)

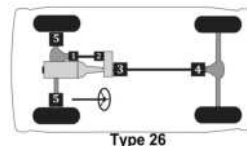
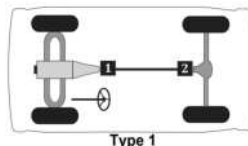

Passenger cars, light & medium trucks

Plymouth Truck Trailduster -- (Cont.)

MFG./YEAR	MODEL & LOCATION	PART NO.	MFG./YEAR	MODEL & LOCATION	PART NO.
Drive Shaft (4 W/D) (Cont.)			Drive Shaft (4 W/D) (Cont.)		
U-Joint (Cont.)			U-Joint (Cont.)		
1976-1974 w/ Frt. Shaft Inner Lock Rings & 2.625" Rear Shaft Yoke: [Type 26]			1976-1974 w/ Frt. Shaft Outer Lock Rings & 2.125" Rear Shaft Yoke: [Type 26]		
U-Joint (Frt. Shaft; Frt.) [⊙]		UJ315G	U-Joint (Frt. Shaft; Frt.) [⊙]		UJ315G
Brute Force Greaseable		UJ246	Brute Force Greaseable		UJ246
Clamp Kit (Frt. Shaft; Frt.)		UJ318-10	Clamp Kit (Frt. Shaft; Frt.)		UJ318-10
U-Joint (Frt. Shaft; Rr.) [⊙]	[2]	UJ534G	U-Joint (Frt. Shaft; Rr.) [⊙]	[2]	UJ379
Brute Force Greaseable		UJ235	Brute Force Greaseable		UJ280
Brute Force Non Greaseable		UJ234	Brute Force Non Greaseable		UJ269
U-Joint (Rr. Shaft; Frt.) [⊙]		UJ315G	U-Joint (Rr. Shaft; Frt.) [⊙]		UJ315G
Brute Force Greaseable		UJ246	Brute Force Greaseable		UJ246
Clamp Kit (Rr. Shaft; Frt.)		UJ318-10	Clamp Kit (Rr. Shaft; Frt.)		UJ318-10
U-Joint (Rr. Shaft; Rr.) [⊙]		UJ316	U-Joint (Rr. Shaft; Rr.) [⊙]		UJ315G
Brute Force Greaseable		UJ248	Brute Force Greaseable		UJ246
Clamp Kit (Rr. Shaft; Rr.)		UJ316-10	Clamp Kit (Rr. Shaft; Rr.)		UJ318-10
U-Joint (Wheel Joint) [⊙]	[2]	UJ371	U-Joint (Wheel Joint) [⊙]	[2]	UJ371
Brute Force Greaseable		UJ377	Brute Force Greaseable		UJ377
Brute Force Non Greaseable		UJ371	Brute Force Non Greaseable		UJ371
Ball Seat Repair Kit		UJ606	Centering Yoke		UJ607
Flange Yoke		UJ626	H Yoke		UJ647
H Yoke		UJ646			(Continued)

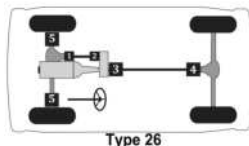

538 ▲ For Use w/ 1.063" Bearing Cap Application. ⊙ For Use w/ 1.188" Bearing Cap Application. ◇ For Use w/ Inner Lock Ring Application on Half Shaft. □ For Use w/ Outer Lock Ring Application on Half Shaft.

Passenger cars, light & medium trucks

(Cont.) -- Plymouth Truck Trailduster

MFG./YEAR	MODEL & LOCATION	PART NO.	MFG./YEAR	MODEL & LOCATION	PART NO.
Drive Shaft (4 W/D) (Cont.)			Drive Shaft (4 W/D) (Cont.)		
U-Joint (Cont.)			U-Joint (Cont.)		
			1976-1974 w/ Frt. Shaft Outer Lock Rings & 2.625" Rear Shaft Yoke: [Type 26]		
	U-Joint (Frt. Shaft; Frt.) ①	UJ315G		U-Joint (Rr. Shaft; Frt.) ③	UJ315G
	<i>Brute Force Greaseable</i>	UJ246		<i>Brute Force Greaseable</i>	UJ246
	Clamp Kit (Frt. Shaft; Frt.)	UJ318-10		Clamp Kit (Rr. Shaft; Frt.)	UJ318-10
	U-Joint (Frt. Shaft; Rr.) ②	[2] UJ379		U-Joint (Rr. Shaft; Rr.) ④	UJ316
	<i>Brute Force Greaseable</i>	UJ280		<i>Brute Force Greaseable</i>	UJ248
	<i>Brute Force Non Greaseable</i>	UJ269		Clamp Kit (Rr. Shaft; Rr.)	UJ316-10
	U-Joint (Rr. Shaft; Frt.) ③	UJ315G		U-Joint (Wheel Joint) ⑤	[2] UJ371
	<i>Brute Force Greaseable</i>	UJ246		<i>Brute Force Greaseable</i>	UJ377
	<i>Brute Force Non Greaseable</i>	UJ269		<i>Brute Force Non Greaseable</i>	UJ371
	U-Joint (Rr. Shaft; Rr.) ④	UJ316		Centering Yoke	UJ607
	<i>Brute Force Greaseable</i>	UJ248		H Yoke	UJ647
	Clamp Kit (Rr. Shaft; Frt.)	UJ318-10			
	U-Joint (Rr. Shaft; Rr.) ④	UJ316			
	<i>Brute Force Greaseable</i>	UJ248			
	Clamp Kit (Rr. Shaft; Rr.)	UJ316-10			
	U-Joint (Wheel Joint) ⑤	[2] UJ371			
	<i>Brute Force Greaseable</i>	UJ377			
	<i>Brute Force Non Greaseable</i>	UJ371			
	Centering Yoke	UJ607			
	H Yoke	UJ647			

Pontiac CUV Torrent

Drive Shaft (AWD)		
U-Joint		
2006	All: [Type 43]	
	U-Joint (Rr. Shaft; Ctr.) ①	UJ10439
	U-Joint (Rr. Shaft; Rr.) ②	UJ409

RAM 1/2 Ton

Drive Shaft (2 W/D)		
U-Joint		
2022-2019 1500 w/ 2 Joint Shaft:		
	U-Joint (Front)	UJ331
	<i>Brute Force Greaseable</i>	UJ232
	<i>Brute Force Non Greaseable</i>	UJ231
	(For Aluminum Drive Shaft)	UJ331C
	U-Joint (Rear)	UJ331
	<i>Brute Force Greaseable</i>	UJ232
	<i>Brute Force Non Greaseable</i>	UJ231
	(For Aluminum Drive Shaft)	UJ331C

Drive Shaft (2 W/D) (Cont.)		
U-Joint (Cont.)		
2022-2019 1500 w/ 3 Joint Shaft:		
	U-Joint (Front)	UJ331
	<i>Brute Force Greaseable</i>	UJ232
	<i>Brute Force Non Greaseable</i>	UJ231
	(For Aluminum Drive Shaft)	UJ331C
	U-Joint (Center)	UJ331
	<i>Brute Force Greaseable</i>	UJ232
	<i>Brute Force Non Greaseable</i>	UJ231
	(For Aluminum Drive Shaft)	UJ331C
	U-Joint (Rear)	UJ331
	<i>Brute Force Greaseable</i>	UJ232
	<i>Brute Force Non Greaseable</i>	UJ231
	(For Aluminum Drive Shaft)	UJ331C
		(Continued)

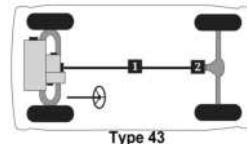
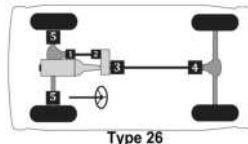

Passenger cars, light & medium trucks

RAM 1/2 Ton -- (Cont.)

MFG./YEAR	MODEL & LOCATION	PART NO.	MFG./YEAR	MODEL & LOCATION	PART NO.
Drive Shaft (2 W/D) (Cont.)			Drive Shaft (2 W/D) (Cont.)		
U-Joint (Cont.)			U-Joint (Cont.)		
2018-2014 1500 w/ 2 Joint Shaft: [Type 1]			2011 Dakota w/ 3 Joint Shaft: [Type 2]		
U-Joint (Front)Ⓛ		UJ331	U-Joint (Front)Ⓛ		UJ354
Brute Force Greaseable		UJ232	Brute Force Greaseable		UJ270
Brute Force Non Greaseable		UJ231	Brute Force Non Greaseable		UJ254
(For Aluminum Drive Shaft)		UJ331C	(For Aluminum Drive Shaft)		UJ354C
U-Joint (Rear)Ⓢ		UJ331	U-Joint (Center)Ⓢ		UJ354
Brute Force Greaseable		UJ232	Brute Force Greaseable		UJ270
Brute Force Non Greaseable		UJ231	Brute Force Non Greaseable		UJ254
(For Aluminum Drive Shaft)		UJ331C	(For Aluminum Drive Shaft)		UJ354C
2018-2014 1500 w/ 3 Joint Shaft: [Type 2]			U-Joint (Rear)Ⓢ		
U-Joint (Front)Ⓛ		UJ331	Brute Force Greaseable		UJ270
Brute Force Greaseable		UJ232	Brute Force Non Greaseable		UJ254
Brute Force Non Greaseable		UJ231	(For Aluminum Drive Shaft)		UJ354C
(For Aluminum Drive Shaft)		UJ331C	Drive Shaft (4 W/D)		
U-Joint (Center)Ⓢ		UJ331	U-Joint		
Brute Force Greaseable		UJ232	2022-2019 1500 w/ 2 Joint Shaft:		
Brute Force Non Greaseable		UJ231	U-Joint (Rr. Shaft; Frt.)		UJ331
(For Aluminum Drive Shaft)		UJ331C	Brute Force Greaseable		UJ232
U-Joint (Rear)Ⓢ		UJ331	Brute Force Non Greaseable		UJ231
Brute Force Greaseable		UJ232	(For Aluminum Drive Shaft)		UJ331C
Brute Force Non Greaseable		UJ231	U-Joint (Rr. Shaft; Rr.)		UJ331
(For Aluminum Drive Shaft)		UJ331C	Brute Force Greaseable		UJ232
2013-2011 1500 w/ 2 Joint Shaft: [Type 1]			Brute Force Non Greaseable		UJ231
U-Joint (Front)Ⓛ		UJ331	(For Aluminum Drive Shaft)		UJ331C
Brute Force Greaseable		UJ232	2022-2019 1500 w/ 3 Joint Shaft:		
Brute Force Non Greaseable		UJ231	U-Joint (Rr. Shaft; Frt.)		UJ331
(For Aluminum Drive Shaft)		UJ331C	Brute Force Greaseable		UJ232
U-Joint (Rear)Ⓢ		UJ331	Brute Force Non Greaseable		UJ231
Brute Force Greaseable		UJ232	(For Aluminum Drive Shaft)		UJ331C
Brute Force Non Greaseable		UJ231	U-Joint (Rr. Shaft; Ctr.)		UJ331
(For Aluminum Drive Shaft)		UJ331C	Brute Force Greaseable		UJ232
2013-2011 1500 w/ 3 Joint Shaft: [Type 2]			Brute Force Non Greaseable		UJ231
U-Joint (Front)Ⓛ		UJ354	(For Aluminum Drive Shaft)		UJ331C
Brute Force Greaseable		UJ270	U-Joint (Rr. Shaft; Rr.)		UJ331
Brute Force Non Greaseable		UJ254	Brute Force Greaseable		UJ232
(For Aluminum Drive Shaft)		UJ354C	Brute Force Non Greaseable		UJ231
U-Joint (Center)Ⓢ		UJ354	(For Aluminum Drive Shaft)		UJ331C
Brute Force Greaseable		UJ270	2018-2014 1500 w/ 2 Joint Shaft: [Type 17]		
Brute Force Non Greaseable		UJ254	U-Joint (Rr. Shaft; Frt.)Ⓛ		UJ331
(For Aluminum Drive Shaft)		UJ354C	Brute Force Greaseable		UJ232
U-Joint (Rear)Ⓢ		UJ354	Brute Force Non Greaseable		UJ231
Brute Force Greaseable		UJ270	(For Aluminum Drive Shaft)		UJ331C
Brute Force Non Greaseable		UJ254	U-Joint (Rr. Shaft; Rr.)Ⓢ		UJ331
(For Aluminum Drive Shaft)		UJ354C	Brute Force Greaseable		UJ232
2011 Dakota w/ 2 Joint Shaft: [Type 1]			Brute Force Non Greaseable		UJ231
U-Joint (Front)Ⓛ		UJ354	(For Aluminum Drive Shaft)		UJ331C
Brute Force Greaseable		UJ270	(Continued)		
Brute Force Non Greaseable		UJ254			
(For Aluminum Drive Shaft)		UJ354C			
U-Joint (Rear)Ⓢ		UJ354			
Brute Force Greaseable		UJ270			
Brute Force Non Greaseable		UJ254			
(For Aluminum Drive Shaft)		UJ354C			

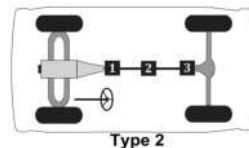
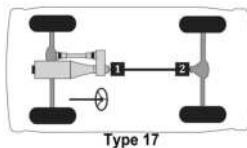
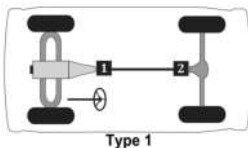

MFG./YEAR	MODEL & LOCATION	PART NO.	MFG./YEAR	MODEL & LOCATION	PART NO.
Drive Shaft (4 W/D) (Cont.)			Drive Shaft (4 W/D) (Cont.)		
U-Joint (Cont.)			U-Joint (Cont.)		
2018-2014 1500 w/ 3 Joint Shaft: [Type 18]			2013-2011 1500 w/ 3 Joint Shaft: [Type 16]		
	U-Joint (Rr. Shaft; Frt.) [Ⓢ]	UJ331		U-Joint (Frt. Shaft; Frt.) [Ⓢ]	UJ354
	Brute Force Greaseable	UJ232		Brute Force Greaseable	UJ270
	Brute Force Non Greaseable	UJ231		Brute Force Non Greaseable	UJ254
	(For Aluminum Drive Shaft)	UJ331C		(For Aluminum Drive Shaft)	UJ354C
	U-Joint (Rr. Shaft; Ctr.) [Ⓢ]	UJ331		U-Joint (Rr. Shaft; Frt.) [Ⓢ]	UJ354
	Brute Force Greaseable	UJ232		Brute Force Greaseable	UJ270
	Brute Force Non Greaseable	UJ231		Brute Force Non Greaseable	UJ254
	(For Aluminum Drive Shaft)	UJ331C		(For Aluminum Drive Shaft)	UJ354C
	U-Joint (Rr. Shaft; Rr.) [Ⓢ]	UJ331		U-Joint (Rr. Shaft; Ctr.) [Ⓢ]	UJ354
	Brute Force Greaseable	UJ232		Brute Force Greaseable	UJ270
	Brute Force Non Greaseable	UJ231		Brute Force Non Greaseable	UJ254
	(For Aluminum Drive Shaft)	UJ331C		(For Aluminum Drive Shaft)	UJ354C
	2013-2011 1500 w/ 2 Joint Shaft: [Type 15]			U-Joint (Rr. Shaft; Rr.)[Ⓢ]	UJ354
	U-Joint (Frt. Shaft; Frt.) [Ⓢ]	UJ354		Brute Force Greaseable	UJ270
	Brute Force Greaseable	UJ270		Brute Force Non Greaseable	UJ254
	Brute Force Non Greaseable	UJ254		(For Aluminum Drive Shaft)	UJ354C
	(For Aluminum Drive Shaft)	UJ354C		2011 Dakota: [Type 15]	
	U-Joint (Rr. Shaft; Frt.) [Ⓢ]	UJ331		U-Joint (Frt. Shaft; Frt.) [Ⓢ]	UJ369
	Brute Force Greaseable	UJ232		Brute Force Greaseable	UJ280
	Brute Force Non Greaseable	UJ231		Brute Force Non Greaseable	UJ269
	(For Aluminum Drive Shaft)	UJ331C		(For Aluminum Drive Shaft)	UJ369C
	U-Joint (Rr. Shaft; Rr.) [Ⓢ]	UJ331		U-Joint (Rr. Shaft; Frt.) [Ⓢ]	UJ354
	Brute Force Greaseable	UJ232		Brute Force Greaseable	UJ270
	Brute Force Non Greaseable	UJ231		Brute Force Non Greaseable	UJ254
	(For Aluminum Drive Shaft)	UJ331C		(For Aluminum Drive Shaft)	UJ354C
				U-Joint (Rr. Shaft; Rr.) [Ⓢ]	UJ354
				Brute Force Greaseable	UJ270
				Brute Force Non Greaseable	UJ254
				(For Aluminum Drive Shaft)	UJ354C

RAM 3/4 Ton

Drive Shaft (2 W/D)			Drive Shaft (2 W/D) (Cont.)		
U-Joint			U-Joint (Cont.)		
2019-2013 2500 w/ 2 Joint Shaft: [Type 1]			2012-2011 2500 w/ Gas Eng. & 2 Joint Shaft: [Type 1]		
	U-Joint (Front) [Ⓢ]	UJ330A		U-Joint (Front) [Ⓢ]	UJ330A
	Brute Force Greaseable	UJ295A		Brute Force Greaseable	UJ295A
	U-Joint (Rear) [Ⓢ]	UJ330A		U-Joint (Rear) [Ⓢ]	UJ330A
	Brute Force Greaseable	UJ295A		Brute Force Greaseable	UJ295A
2019-2013 2500 w/ 3 Joint Shaft: [Type 2]			2012-2011 2500 w/ Diesel Eng. & 3 Joint Shaft: [Type 2]		
	U-Joint (Front) [Ⓢ]	UJ358		U-Joint (Front) [Ⓢ]	UJ351A
	Brute Force Non Greaseable	UJ358BF		Brute Force Non Greaseable	UJ351ABF
	U-Joint (Center) [Ⓢ]	UJ358		U-Joint (Center) [Ⓢ]	UJ351A
	Brute Force Non Greaseable	UJ358BF		Brute Force Non Greaseable	UJ351ABF
	U-Joint (Rear) [Ⓢ]	UJ358		U-Joint (Rear) [Ⓢ]	UJ351A
	Brute Force Non Greaseable	UJ358BF		Brute Force Non Greaseable	UJ351ABF
2012-2011 2500 w/ Diesel Eng. & 2 Joint Shaft: [Type 1]					
	U-Joint (Front) [Ⓢ]	UJ351A			
	Brute Force Non Greaseable	UJ351ABF			
	U-Joint (Rear) [Ⓢ]	UJ351A			
	Brute Force Non Greaseable	UJ351ABF			

(Continued)

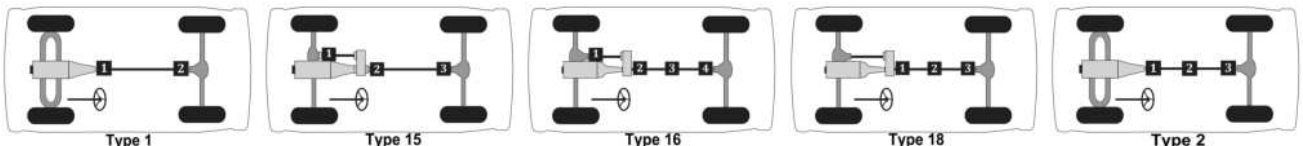

Passenger cars, light & medium trucks

RAM 3/4 Ton -- (Cont.)

MFG./YEAR MODEL & LOCATION PART NO. MFG./YEAR MODEL & LOCATION PART NO.

Drive Shaft (2 W/D) (Cont.)

U-Joint (Cont.)

2012-2011 2500 w/ Gas Eng. & 3 Joint Shaft:

[Type 2]

U-Joint (Front)Ⓚ	UJ330A
Brute Force Greaseable	UJ295A
U-Joint (Center)Ⓚ	UJ330A
Brute Force Greaseable	UJ295A
U-Joint (Rear)Ⓚ	UJ330A
Brute Force Greaseable	UJ295A

Drive Shaft (4 W/D)

U-Joint

2019-2013 2500 w/ 2 Joint Rr. Shaft Serrated Frt.

Pin. Flange: [Type 26]

U-Joint (Frt. Shaft; Frt.)Ⓚ	UJ331
Brute Force Greaseable	UJ232
Brute Force Non Greaseable	UJ231
(For Aluminum Drive Shaft)	UJ331C
U-Joint (Frt. Shaft; Rr.)Ⓚ	[2] UJ331
Brute Force Greaseable	UJ232
Brute Force Non Greaseable	UJ231
(For Aluminum Drive Shaft)	UJ331C
U-Joint (Rr. Shaft; Frt.)Ⓚ	UJ330A
Brute Force Greaseable	UJ295A
U-Joint (Rr. Shaft; Rr.)Ⓚ	UJ330A
Brute Force Greaseable	UJ295A
U-Joint (Wheel Joint)Ⓚ	[2] UJ479
Centering Ball Kit	UJ617
H Yoke	UJ650

2019-2013 2500 w/ 3 Joint Rr. Shaft Serrated Frt.

Pin. Flange: [Type 27]

U-Joint (Frt. Shaft; Frt.)Ⓚ	UJ331
Brute Force Greaseable	UJ232
Brute Force Non Greaseable	UJ231
(For Aluminum Drive Shaft)	UJ331C
U-Joint (Frt. Shaft; Rr.)Ⓚ	[2] UJ331
Brute Force Greaseable	UJ232
Brute Force Non Greaseable	UJ231
(For Aluminum Drive Shaft)	UJ331C
U-Joint (Rr. Shaft; Frt.)Ⓚ	UJ358
Brute Force Non Greaseable	UJ358BF
U-Joint (Rr. Shaft; Ctr.)Ⓚ	UJ358
Brute Force Non Greaseable	UJ358BF
U-Joint (Rr. Shaft; Rr.)Ⓚ	UJ358
Brute Force Non Greaseable	UJ358BF
U-Joint (Wheel Joint)Ⓚ	[2] UJ479
Centering Ball Kit	UJ617
H Yoke	UJ650

Drive Shaft (4 W/D) (Cont.)

U-Joint (Cont.)

2019-2013 2500 w/ 2 Joint Rr. Shaft Flat Faced

Frnt. Pin. Flange: [Type 26]

U-Joint (Frt. Shaft; Frt.)Ⓚ	UJ330
Brute Force Greaseable	UJ295
(For Aluminum Drive Shaft)	UJ330C
U-Joint (Frt. Shaft; Rr.)Ⓚ	[2] UJ330
Brute Force Greaseable	UJ295
(For Aluminum Drive Shaft)	UJ330C
U-Joint (Rr. Shaft; Frt.)Ⓚ	UJ330A
Brute Force Greaseable	UJ295A
U-Joint (Rr. Shaft; Rr.)Ⓚ	UJ330A
Brute Force Greaseable	UJ295A
U-Joint (Wheel Joint)Ⓚ	[2] UJ479
Centering Ball Kit	UJ617
H Yoke	UJ650

2019-2013 2500 w/ 3 Joint Rr. Shaft Flat Faced

Frnt. Pin. Flange: [Type 27]

U-Joint (Frt. Shaft; Frt.)Ⓚ	UJ330
Brute Force Greaseable	UJ295
(For Aluminum Drive Shaft)	UJ330C
U-Joint (Frt. Shaft; Rr.)Ⓚ	[2] UJ330
Brute Force Greaseable	UJ295
(For Aluminum Drive Shaft)	UJ330C
U-Joint (Rr. Shaft; Frt.)Ⓚ	UJ358
Brute Force Non Greaseable	UJ358BF
U-Joint (Rr. Shaft; Ctr.)Ⓚ	UJ358
Brute Force Non Greaseable	UJ358BF
U-Joint (Rr. Shaft; Rr.)Ⓚ	UJ358
Brute Force Non Greaseable	UJ358BF
U-Joint (Wheel Joint)Ⓚ	[2] UJ479
Centering Ball Kit	UJ617
H Yoke	UJ650

2012-2011 2500 w/ Gas Eng. & 2 Joint Shaft:

[Type 26]

U-Joint (Frt. Shaft; Frt.)Ⓚ	UJ331
Brute Force Greaseable	UJ232
Brute Force Non Greaseable	UJ231
(For Aluminum Drive Shaft)	UJ331C
U-Joint (Frt. Shaft; Rr.)Ⓚ	[2] UJ331
Brute Force Greaseable	UJ232
Brute Force Non Greaseable	UJ231
(For Aluminum Drive Shaft)	UJ331C
U-Joint (Rr. Shaft; Frt.)Ⓚ	UJ330A
Brute Force Greaseable	UJ295A
U-Joint (Rr. Shaft; Rr.)Ⓚ	UJ330A
Brute Force Greaseable	UJ295A
U-Joint (Wheel Joint)Ⓚ	[2] UJ479
Centering Ball Kit	UJ617
H Yoke	UJ650

(Continued)

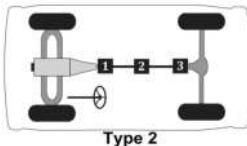

Type 2

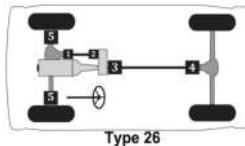

Type 26

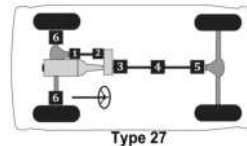

Type 27

SKF

MFG./YEAR	MODEL & LOCATION	PART NO.	MFG./YEAR	MODEL & LOCATION	PART NO.
Drive Shaft (4 W/D) (Cont.)			Drive Shaft (4 W/D) (Cont.)		
U-Joint (Cont.)			U-Joint (Cont.)		
2012-2011 2500 w/ Gas Eng. & 3 Joint Shaft:			2012-2011 2500 w/ Diesel Eng. & 3 Joint Shaft:		
[Type 27]			[Type 27]		
U-Joint (Fr. Shaft; Fr.) ^①		UJ331	U-Joint (Fr. Shaft; Fr.) ^①		UJ331
Brute Force Greaseable		UJ232	Brute Force Greaseable		UJ232
Brute Force Non Greaseable		UJ231	Brute Force Non Greaseable		UJ231
(For Aluminum Drive Shaft)		UJ331C	(For Aluminum Drive Shaft)		UJ331C
U-Joint (Fr. Shaft; Rr.) ^②	[2]	UJ331	U-Joint (Fr. Shaft; Rr.) ^②	[2]	UJ331
Brute Force Greaseable		UJ232	Brute Force Greaseable		UJ232
Brute Force Non Greaseable		UJ231	Brute Force Non Greaseable		UJ231
(For Aluminum Drive Shaft)		UJ331C	(For Aluminum Drive Shaft)		UJ331C
U-Joint (Rr. Shaft; Fr.) ^③		UJ330A	U-Joint (Rr. Shaft; Fr.) ^③		UJ351A
Brute Force Greaseable		UJ295A	Brute Force Non Greaseable		UJ351ABF
U-Joint (Rr. Shaft; Ctr.) ^④		UJ330A	U-Joint (Rr. Shaft; Ctr.) ^④		UJ351A
Brute Force Greaseable		UJ295A	Brute Force Non Greaseable		UJ351ABF
U-Joint (Rr. Shaft; Rr.) ^⑤		UJ330A	U-Joint (Rr. Shaft; Rr.) ^⑤		UJ351A
Brute Force Greaseable		UJ295A	Brute Force Non Greaseable		UJ351ABF
U-Joint (Wheel Joint) ^⑥	[2]	UJ479	U-Joint (Wheel Joint) ^⑥	[2]	UJ479
Centering Ball Kit		UJ617	Centering Ball Kit		UJ617
H Yoke		UJ650	H Yoke		UJ650
2012-2011 2500 w/ Diesel Eng. & 2 Joint Shaft:					
[Type 26]					
U-Joint (Fr. Shaft; Fr.) ^①		UJ331			
Brute Force Greaseable		UJ232			
Brute Force Non Greaseable		UJ231			
(For Aluminum Drive Shaft)		UJ331C			
U-Joint (Fr. Shaft; Rr.) ^②	[2]	UJ331			
Brute Force Greaseable		UJ232			
Brute Force Non Greaseable		UJ231			
(For Aluminum Drive Shaft)		UJ331C			
U-Joint (Rr. Shaft; Fr.) ^③		UJ351A			
Brute Force Non Greaseable		UJ351ABF			
U-Joint (Rr. Shaft; Rr.) ^④		UJ351A			
Brute Force Non Greaseable		UJ351ABF			
U-Joint (Wheel Joint) ^⑥	[2]	UJ479			
Centering Ball Kit		UJ617			
H Yoke		UJ650			

RAM 1 Ton

Drive Shaft (2 W/D)

U-Joint

2019-2013 3500 w/ 2 Joint Rr. Shaft: [Type 1]

U-Joint (Front)^① UJ358SP

U-Joint (Rear)^② UJ358SP

2019-2013 3500 w/ 3 Joint Rr. Shaft: [Type 2]

U-Joint (Front)^① UJ358SP

U-Joint (Center)^③ UJ358SP

U-Joint (Rear)^④ UJ358SP

Drive Shaft (2 W/D) (Cont.)

U-Joint (Cont.)

2012-2011 3500 w/ 2 Joint Shaft & Single Rear
Wheels: [Type 1]

U-Joint (Front)^① UJ351A

Brute Force Non Greaseable UJ351ABF

U-Joint (Rear)^② UJ351A

Brute Force Non Greaseable UJ351ABF

(Continued)

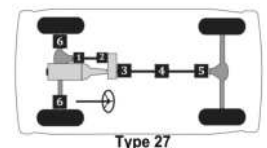
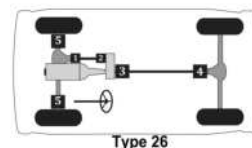
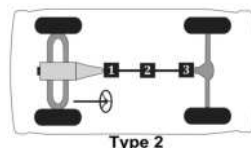
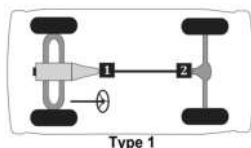

Passenger cars, light & medium trucks

RAM 1 Ton -- (Cont.)

MFG./YEAR	MODEL & LOCATION	PART NO.	MFG./YEAR	MODEL & LOCATION	PART NO.
Drive Shaft (2 W/D) (Cont.)			Drive Shaft (4 W/D) (Cont.)		
U-Joint (Cont.)			U-Joint (Cont.)		
2012-2011 3500 w/ 2 Joint Shaft & Dual Rear			2019-2013 3500 w/ 3 Joint Rr. Shaft & Flat Faced		
Wheels: [Type 1]			Frnt. Pin. Flange: [Type 27]		
U-Joint (Front)Ⓚ		UJ358A	U-Joint (Frnt. Shaft; Frnt.)Ⓚ		UJ330
Brute Force Non Greaseable		UJ358ABF	Brute Force Greaseable		UJ295
U-Joint (Rear)Ⓚ		UJ358A	(For Aluminum Drive Shaft)		UJ330C
Brute Force Non Greaseable		UJ358ABF	U-Joint (Frnt. Shaft; Rr.)Ⓚ		UJ330
2012-2011 3500 w/ 3 Joint Shaft & Single Rear			Brute Force Greaseable		UJ295
Wheels: [Type 2]			(For Aluminum Drive Shaft)		UJ330C
U-Joint (Front)Ⓚ		UJ351A	U-Joint (Rr. Shaft; Frnt.)Ⓚ	[1]	UJ358SP
Brute Force Non Greaseable		UJ351ABF	U-Joint (Rr. Shaft; Ctr.)Ⓚ	[1]	UJ358SP
U-Joint (Center)Ⓚ		UJ351A	U-Joint (Rr. Shaft; Rr.)Ⓚ	[1]	UJ358SP
Brute Force Non Greaseable		UJ351ABF	U-Joint (Wheel Joint)Ⓚ	[2]	UJ479
U-Joint (Rear)Ⓚ		UJ351A	2019-2013 3500 w/ 3 Joint Rr. Shaft & Serrated		
Brute Force Non Greaseable		UJ351ABF	Frnt. Pin. Flange: [Type 27]		
2012-2011 3500 w/ 3 Joint Shaft & Dual Rear			U-Joint (Frnt. Shaft; Frnt.)Ⓚ		UJ331
Wheels: [Type 2]			Brute Force Greaseable		UJ232
U-Joint (Front)Ⓚ		UJ358A	Brute Force Non Greaseable		UJ231
Brute Force Non Greaseable		UJ358ABF	(For Aluminum Drive Shaft)		UJ331C
U-Joint (Center)Ⓚ		UJ358A	U-Joint (Frnt. Shaft; Rr.)Ⓚ		UJ331
Brute Force Non Greaseable		UJ358ABF	Brute Force Greaseable		UJ232
U-Joint (Rear)Ⓚ		UJ358A	Brute Force Non Greaseable		UJ231
Brute Force Non Greaseable		UJ358ABF	(For Aluminum Drive Shaft)		UJ331C
Drive Shaft (4 W/D)			U-Joint (Rr. Shaft; Frnt.)Ⓚ		UJ358SP
U-Joint			U-Joint (Rr. Shaft; Ctr.)Ⓚ		UJ358SP
2019-2013 3500 w/ 2 Joint Rr. Shaft & Flat Faced			U-Joint (Rr. Shaft; Rr.)Ⓚ		UJ358SP
Frnt. Pin. Flange: [Type 26]			U-Joint (Wheel Joint)Ⓚ	[2]	UJ479
U-Joint (Frnt. Shaft; Frnt.)Ⓚ		UJ330	2012-2011 3500 w/ 2 Joint Shaft & Dual Rear		
Brute Force Greaseable		UJ295	Wheels: [Type 26]		
(For Aluminum Drive Shaft)		UJ330C	U-Joint (Frnt. Shaft; Frnt.)Ⓚ		UJ331
U-Joint (Frnt. Shaft; Rr.)Ⓚ		UJ330	Brute Force Greaseable		UJ232
Brute Force Greaseable		UJ295	Brute Force Non Greaseable		UJ231
(For Aluminum Drive Shaft)		UJ330C	(For Aluminum Drive Shaft)		UJ331C
U-Joint (Rr. Shaft; Frnt.)Ⓚ		UJ358SP	U-Joint (Frnt. Shaft; Rr.)Ⓚ	[2]	UJ331
U-Joint (Rr. Shaft; Rr.)Ⓚ		UJ358SP	Brute Force Greaseable		UJ232
U-Joint (Wheel Joint)Ⓚ	[2]	UJ479	Brute Force Non Greaseable		UJ231
2019-2013 3500 w/ 2 Joint Rr. Shaft & Serrated			(For Aluminum Drive Shaft)		UJ331C
Frnt. Pin. Flange: [Type 26]			U-Joint (Rr. Shaft; Frnt.)Ⓚ		UJ358A
U-Joint (Frnt. Shaft; Frnt.)Ⓚ		UJ331	Brute Force Non Greaseable		UJ358ABF
Brute Force Greaseable		UJ232	U-Joint (Rr. Shaft; Rr.)Ⓚ		UJ358A
Brute Force Non Greaseable		UJ231	Brute Force Non Greaseable		UJ358ABF
(For Aluminum Drive Shaft)		UJ331C	U-Joint (Wheel Joint)Ⓚ	[2]	UJ479
U-Joint (Frnt. Shaft; Rr.)Ⓚ		UJ331	Centering Ball Kit		UJ617
Brute Force Greaseable		UJ232	H Yoke		UJ650
Brute Force Non Greaseable		UJ231			(Continued)
(For Aluminum Drive Shaft)		UJ331C			
U-Joint (Rr. Shaft; Frnt.)Ⓚ		UJ358SP			
U-Joint (Rr. Shaft; Rr.)Ⓚ		UJ358SP			
U-Joint (Wheel Joint)Ⓚ	[2]	UJ479			

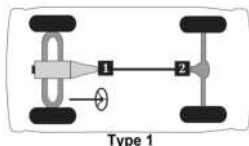

Type 1

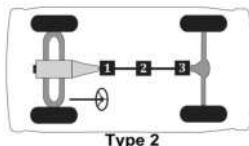

Type 2

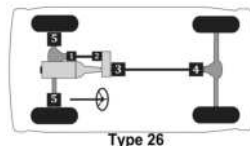

Type 26

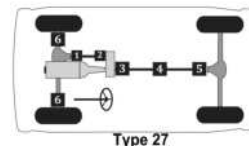

Type 27

SKF

MFG./YEAR	MODEL & LOCATION	PART NO.	MFG./YEAR	MODEL & LOCATION	PART NO.
Drive Shaft (4 W/D) (Cont.)			Drive Shaft (4 W/D) (Cont.)		
U-Joint (Cont.)			U-Joint (Cont.)		
2012-2011 3500 w/ 2 Joint Shaft & Single Rear			2012-2011 3500 w/ 3 Joint Shaft & Dual Rear		
Wheels: [Type 26]			Wheels: [Type 27]		
U-Joint (Frnt. Shaft; Frnt.) ^①		UJ331	U-Joint (Frnt. Shaft; Frnt.) ^①		UJ331
Brute Force Greaseable		UJ232	Brute Force Greaseable		UJ232
Brute Force Non Greaseable		UJ231	Brute Force Non Greaseable		UJ231
(For Aluminum Drive Shaft)		UJ331C	(For Aluminum Drive Shaft)		UJ331C
U-Joint (Frnt. Shaft; Rr.) ^②	[2]	UJ331	U-Joint (Frnt. Shaft; Rr.) ^②	[2]	UJ331
Brute Force Greaseable		UJ232	Brute Force Greaseable		UJ232
Brute Force Non Greaseable		UJ231	Brute Force Non Greaseable		UJ231
(For Aluminum Drive Shaft)		UJ331C	(For Aluminum Drive Shaft)		UJ331C
U-Joint (Rr. Shaft; Frnt.) ^③		UJ351A	U-Joint (Rr. Shaft; Frnt.) ^③		UJ358A
Brute Force Non Greaseable		UJ351ABF	Brute Force Non Greaseable		UJ358ABF
U-Joint (Rr. Shaft; Rr.) ^④		UJ351A	U-Joint (Rr. Shaft; Ctr.) ^④		UJ358A
Brute Force Non Greaseable		UJ351ABF	Brute Force Non Greaseable		UJ358ABF
U-Joint (Wheel Joint) ^⑤	[2]	UJ479	U-Joint (Rr. Shaft; Rr.) ^⑤		UJ358A
Centering Ball Kit		UJ617	Brute Force Non Greaseable		UJ358ABF
H Yoke		UJ650	U-Joint (Wheel Joint) ^⑥	[2]	UJ479
			Centering Ball Kit		UJ617
			H Yoke		UJ650
2012-2011 3500 w/ 3 Joint Shaft & Single Rear			2012-2011 3500 Cab & Chassis w/ 2 Joint Rr.		
Wheels: [Type 27]			Shaft: [Type 26]		
U-Joint (Frnt. Shaft; Frnt.) ^①		UJ331	U-Joint (Frnt. Shaft; Frnt.) ^①		UJ331
Brute Force Greaseable		UJ232	Brute Force Greaseable		UJ232
Brute Force Non Greaseable		UJ231	Brute Force Non Greaseable		UJ231
(For Aluminum Drive Shaft)		UJ331C	(For Aluminum Drive Shaft)		UJ331C
U-Joint (Frnt. Shaft; Rr.) ^②	[2]	UJ331	U-Joint (Frnt. Shaft; Rr.) ^②	[2]	UJ331
Brute Force Greaseable		UJ232	Brute Force Greaseable		UJ232
Brute Force Non Greaseable		UJ231	Brute Force Non Greaseable		UJ231
(For Aluminum Drive Shaft)		UJ331C	(For Aluminum Drive Shaft)		UJ331C
U-Joint (Rr. Shaft; Frnt.) ^③		UJ351A	U-Joint (Rr. Shaft; Frnt.) ^③		UJ358A
Brute Force Non Greaseable		UJ351ABF	Brute Force Non Greaseable		UJ358ABF
U-Joint (Rr. Shaft; Ctr.) ^④		UJ351A	U-Joint (Rr. Shaft; Rr.) ^④		UJ358A
Brute Force Non Greaseable		UJ351ABF	Brute Force Non Greaseable		UJ358ABF
U-Joint (Rr. Shaft; Rr.) ^⑤		UJ351A	U-Joint (Rr. Shaft; Rr.) ^⑤		UJ358A
Brute Force Non Greaseable		UJ351ABF	Brute Force Non Greaseable		UJ358ABF
U-Joint (Wheel Joint) ^⑥	[2]	UJ479	U-Joint (Wheel Joint) ^⑥	[2]	UJ479
Centering Ball Kit		UJ617	Centering Ball Kit		UJ617
H Yoke		UJ650	H Yoke		UJ650

(Continued)

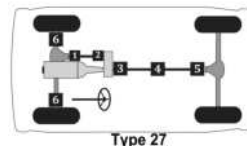
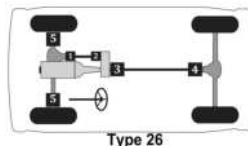

Passenger cars, light & medium trucks

RAM 1 Ton -- (Cont.)

MFG./YEAR	MODEL & LOCATION	PART NO.	MFG./YEAR	MODEL & LOCATION	PART NO.
Drive Shaft (4 W/D) (Cont.)			Drive Shaft (4 W/D) (Cont.)		
U-Joint (Cont.)			U-Joint (Cont.)		
2012-2011 3500 Cab & Chassis w/ 3 Joint Rr. Shaft & Dual Rr. Whls.: [Type 27]			2012-2011 R3500 Cab & Chassis w/ 3 Joint Rr. Shaft & Single Rr. Whls.: [Type 27]		
U-Joint (Fr. Shaft; Frt.)		UJ331	U-Joint (Fr. Shaft; Frt.)		UJ331
Brute Force Greaseable		UJ232	Brute Force Greaseable		UJ232
Brute Force Non Greaseable		UJ231	Brute Force Non Greaseable		UJ231
(For Aluminum Drive Shaft)		UJ331C	(For Aluminum Drive Shaft)		UJ331C
U-Joint (Rr. Shaft; Rr.)	[2]	UJ331	U-Joint (Rr. Shaft; Rr.)	[2]	UJ331
Brute Force Greaseable		UJ232	Brute Force Greaseable		UJ232
Brute Force Non Greaseable		UJ231	Brute Force Non Greaseable		UJ231
(For Aluminum Drive Shaft)		UJ331C	(For Aluminum Drive Shaft)		UJ331C
U-Joint (Rr. Shaft; Frt.)		UJ358A	U-Joint (Rr. Shaft; Frt.)		UJ351A
Brute Force Non Greaseable		UJ358ABF	Brute Force Non Greaseable		UJ351ABF
U-Joint (Rr. Shaft; Ctr.)		UJ358A	U-Joint (Rr. Shaft; Ctr.)		UJ351A
Brute Force Non Greaseable		UJ358ABF	Brute Force Non Greaseable		UJ351ABF
U-Joint (Rr. Shaft; Rr.)		UJ358A	U-Joint (Rr. Shaft; Rr.)		UJ351A
Brute Force Non Greaseable		UJ358ABF	Brute Force Non Greaseable		UJ351ABF
U-Joint (Wheel Joint)	[2]	UJ479	U-Joint (Wheel Joint)	[2]	UJ479
Centering Ball Kit		UJ617	Centering Ball Kit		UJ617
H Yoke		UJ650	H Yoke		UJ650

RAM 1 1/2 Ton, 2 Ton

Drive Shaft (4 X 2)			Drive Shaft (4 X 4)		
U-Joint			U-Joint		
2019-2011 4500 & 5500 w/ 2 Joint Shaft: [Type 1]			2019-2013 4500 & 5500 w/ 2 Joint Shaft: [Type 26]		
U-Joint (Front)		UJ358	U-Joint (Fr. Shaft; Frt.)		UJ330
Brute Force Non Greaseable		UJ358BF	Brute Force Greaseable		UJ295
U-Joint (Rear)		UJ358	(For Aluminum Drive Shaft)		UJ330C
Brute Force Non Greaseable		UJ358BF	U-Joint (Fr. Shaft; Rr.)		UJ330
2019-2011 4500 & 5500 w/ 4 Joint Shaft: [Type 3]			Brute Force Greaseable		UJ295
U-Joint (Front)		UJ358	(For Aluminum Drive Shaft)		UJ330C
Brute Force Non Greaseable		UJ358BF	U-Joint (Rr. Shaft; Frt.)		UJ358SP
U-Joint (Center; Front)		UJ358	U-Joint (Rr. Shaft; Rr.)		UJ358SP
Brute Force Non Greaseable		UJ358BF	U-Joint (Wheel Joint)	[2]	UJ822
U-Joint (Center; Rear)		UJ358	2019-2013 4500 & 5500 w/ 3 Joint Shaft: [Type 27]		
Brute Force Non Greaseable		UJ358BF	U-Joint (Fr. Shaft; Frt.)		UJ330
U-Joint (Rear)		UJ358	Brute Force Greaseable		UJ295
Brute Force Non Greaseable		UJ358BF	(For Aluminum Drive Shaft)		UJ330C
2017-2011 4500 & 5500 w/ 3 Joint Shaft: [Type 2]			U-Joint (Fr. Shaft; Rr.)		UJ330
U-Joint (Front)		UJ358	Brute Force Greaseable		UJ295
Brute Force Non Greaseable		UJ358BF	(For Aluminum Drive Shaft)		UJ330C
U-Joint (Center)		UJ358	U-Joint (Rr. Shaft; Frt.)		UJ358SP
Brute Force Non Greaseable		UJ358BF	U-Joint (Rr. Shaft; Ctr.)		UJ358SP
U-Joint (Rear)		UJ358	U-Joint (Rr. Shaft; Rr.)		UJ358SP
Brute Force Non Greaseable		UJ358BF	U-Joint (Wheel Joint)	[2]	UJ822

(Continued)

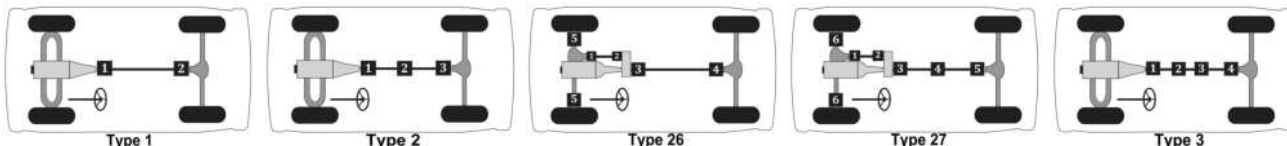

Passenger cars, light & medium trucks

(Cont.) -- RAM 1 1/2 Ton, 2 Ton

MFG./YEAR	MODEL & LOCATION	PART NO.	MFG./YEAR	MODEL & LOCATION	PART NO.
Drive Shaft (4 X 4) (Cont.)			Drive Shaft (4 X 4) (Cont.)		
U-Joint (Cont.)			U-Joint (Cont.)		
2012-2011 4500 & 5500 w/ 2 Joint Shaft: [Type 26]			2012-2011 4500 & 5500 w/ 3 Joint Shaft: [Type 27]		
	U-Joint (Frt. Shaft; Frt.)①	UJ331		U-Joint (Frt. Shaft; Frt.)①	UJ331
	Brute Force Greaseable	UJ232		Brute Force Greaseable	UJ232
	Brute Force Non Greaseable	UJ231		Brute Force Non Greaseable	UJ231
	(For Aluminum Drive Shaft)	UJ331C		(For Aluminum Drive Shaft)	UJ331C
	U-Joint (Frt. Shaft; Rr.)②	[2] UJ331		U-Joint (Frt. Shaft; Rr.)②	[2] UJ331
	Brute Force Greaseable	UJ232		Brute Force Greaseable	UJ232
	Brute Force Non Greaseable	UJ231		Brute Force Non Greaseable	UJ231
	(For Aluminum Drive Shaft)	UJ331C		(For Aluminum Drive Shaft)	UJ331C
	U-Joint (Rr. Shaft; Frt.)③	UJ358SP		U-Joint (Rr. Shaft; Frt.)③	UJ358SP
	U-Joint (Rr. Shaft; Rr.)④	UJ358SP		U-Joint (Rr. Shaft; Ctr.)④	UJ358SP
	U-Joint (Wheel Joint)⑤	[2] UJ822		U-Joint (Rr. Shaft; Rr.)⑤	UJ358SP
	H Yoke	UJ650		U-Joint (Wheel Joint)⑥	[2] UJ822
				H Yoke	UJ650

Rover Discovery, LR4

Drive Shaft (4 W/D)			Drive Shaft (4 W/D) (Cont.)		
U-Joint			U-Joint (Cont.)		
2004-1999 Discovery: [Type 19]			1974-1971 All: [Type 13]		
	U-Joint (Frt. Shaft; Frt.)①	UJ344		U-Joint (Frt. Shaft; Frt.)①	UJ369
	U-Joint (Frt. Shaft; Rr.)②	[2] UJ344		Brute Force Greaseable	UJ280
	U-Joint (Rr. Shaft; Frt.)③	UJ344		Brute Force Non Greaseable	UJ269
	2002-1998 Range Rover: [Type 19]			(For Aluminum Drive Shaft)	UJ369C
	U-Joint (Frt. Shaft; Frt.)①	UJ344		U-Joint (Frt. Shaft; Rr.)②	UJ369
	U-Joint (Frt. Shaft; Rr.)②	UJ344		Brute Force Greaseable	UJ280
	U-Joint (Rr. Shaft; Frt.)③	UJ344		Brute Force Non Greaseable	UJ269
	1998-1994 Discovery: [Type 13]			(For Aluminum Drive Shaft)	UJ369C
	U-Joint (Frt. Shaft; Frt.)①	UJ344		U-Joint (Rr. Shaft; Frt.)③	UJ369
	U-Joint (Frt. Shaft; Rr.)②	UJ344		Brute Force Greaseable	UJ280
	U-Joint (Rr. Shaft; Frt.)③	UJ344		Brute Force Non Greaseable	UJ269
	U-Joint (Rr. Shaft; Rr.)④	UJ344		(For Aluminum Drive Shaft)	UJ369C
	1997-1986 Defender & Range Rover: [Type 13]			U-Joint (Rr. Shaft; Rr.)④	UJ369
	U-Joint (Frt. Shaft; Frt.)①	UJ344		Brute Force Greaseable	UJ280
	U-Joint (Frt. Shaft; Rr.)②	UJ344		Brute Force Non Greaseable	UJ269
	U-Joint (Rr. Shaft; Frt.)③	UJ344		(For Aluminum Drive Shaft)	UJ369C
	U-Joint (Rr. Shaft; Rr.)④	UJ344			(Continued)

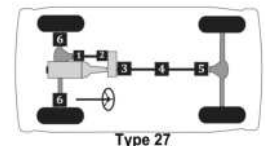
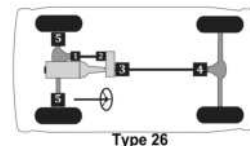
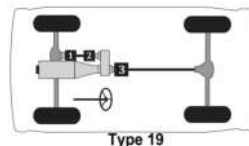
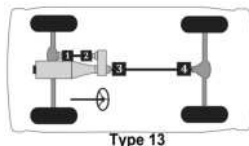

Passenger cars, light & medium trucks

Rover Discovery, LR4 -- (Cont.)

MFG./YEAR	MODEL & LOCATION	PART NO.	MFG./YEAR	MODEL & LOCATION	PART NO.
Drive Shaft (4 W/D) (Cont.)			Drive Shaft (4 W/D) (Cont.)		
U-Joint (Cont.)			U-Joint (Cont.)		
1970-1962 3.5" Rr. Shaft Yokes: [Type 13]			1970-1962 3.25" Rr. Shaft Yokes: [Type 13]		
	U-Joint (Frnt. Shaft; Frnt.) [⊙]	UJ369		U-Joint (Frnt. Shaft; Frnt.) [⊙]	UJ369
	Brute Force Greaseable	UJ280		Brute Force Greaseable	UJ280
	Brute Force Non Greaseable	UJ269		Brute Force Non Greaseable	UJ269
	(For Aluminum Drive Shaft)	UJ369C		(For Aluminum Drive Shaft)	UJ369C
	U-Joint (Frnt. Shaft; Rr.) [⊙]	UJ369		U-Joint (Frnt. Shaft; Rr.) [⊙]	UJ369
	Brute Force Greaseable	UJ280		Brute Force Greaseable	UJ280
	Brute Force Non Greaseable	UJ269		Brute Force Non Greaseable	UJ269
	(For Aluminum Drive Shaft)	UJ369C		(For Aluminum Drive Shaft)	UJ369C
	U-Joint (Rr. Shaft; Frnt.) [⊙]	UJ369		U-Joint (Rr. Shaft; Frnt.) [⊙]	UJ344
	Brute Force Greaseable	UJ280		U-Joint (Rr. Shaft; Rr.) [⊙]	UJ344
	Brute Force Non Greaseable	UJ269		U-Joint (PTO)	UJ369
	(For Aluminum Drive Shaft)	UJ369C		Brute Force Greaseable	UJ280
	U-Joint (Rr. Shaft; Rr.) [⊙]	UJ369		Brute Force Non Greaseable	UJ269
	Brute Force Greaseable	UJ280		(For Aluminum Drive Shaft)	UJ369C
	Brute Force Non Greaseable	UJ269		1961-1950 All: [Type 13]	
	(For Aluminum Drive Shaft)	UJ369C		U-Joint (Frnt. Shaft; Frnt.) [⊙]	UJ344
	U-Joint (PTO)	UJ369		U-Joint (Frnt. Shaft; Rr.) [⊙]	UJ344
	Brute Force Greaseable	UJ280		U-Joint (Rr. Shaft; Frnt.) [⊙]	UJ344
	Brute Force Non Greaseable	UJ269		U-Joint (Rr. Shaft; Rr.) [⊙]	UJ344
	(For Aluminum Drive Shaft)	UJ369C			
	U-Joint (AWD)				
	U-Joint				
	2005-2002 Freelander: [Type 18]				
	U-Joint (Rr. Shaft; Frnt.) [⊙]	UJ341			
	U-Joint (Rr. Shaft; Ctr.) [⊙]	UJ341			
	U-Joint (Rr. Shaft; Rr.) [⊙]	UJ341			

Saab Truck

<p>Drive Shaft (AWD)</p> <p>U-Joint</p> <p>2009-2008 9-7X Aero: [Type 15]</p> <p>U-Joint (Frnt. Shaft; Frnt.)[⊙]UJ445</p> <p>Brute Force GreaseableUJ225</p> <p>Clamp Kit (Frnt. Shaft; Frnt.)UJ360-10</p> <p>U-Joint (Rr. Shaft; Frnt.)[⊙]UJ331A</p> <p>Brute Force GreaseableUJ232A</p> <p>Clamp Kit (Rr. Shaft; Frnt.)UJ492-10</p> <p>U-Joint (Rr. Shaft; Rr.)[⊙]UJ331A</p> <p>Brute Force GreaseableUJ232A</p> <p>Clamp Kit (Rr. Shaft; Rr.)UJ492-10</p>	<p>Drive Shaft (AWD) (Cont.)</p> <p>U-Joint (Cont.)</p> <p>2009-2008 9-7X Exc. Aero: [Type 15]</p> <p>U-Joint (Frnt. Shaft; Frnt.)[⊙]UJ445</p> <p>Brute Force GreaseableUJ225</p> <p>Clamp Kit (Frnt. Shaft; Frnt.)UJ360-10</p> <p>U-Joint (Rr. Shaft; Frnt.)[⊙]UJ534G</p> <p>Brute Force GreaseableUJ235</p> <p>Brute Force Non GreaseableUJ234</p> <p>Clamp Kit (Rr. Shaft; Frnt.)UJ530-10</p> <p>U-Joint (Rr. Shaft; Rr.)[⊙]UJ534G</p> <p>Brute Force GreaseableUJ235</p> <p>Brute Force Non GreaseableUJ234</p> <p>Clamp Kit (Rr. Shaft; Rr.)UJ530-10</p> <p style="text-align: right;">(Continued)</p>
--	---

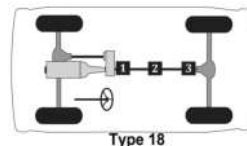
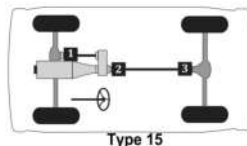
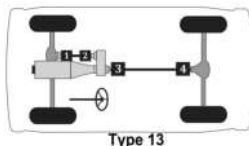

548 ▲ For Use w/ 1.063" Bearing Cap Application. ⊙ For Use w/ 1.188" Bearing Cap Application. ◇ For Use w/ Inner Lock Ring Application on Half Shaft. □ For Use w/ Outer Lock Ring Application on Half Shaft.

Passenger cars, light & medium trucks

(Cont.) -- Saab Truck

MFG./YEAR	MODEL & LOCATION	PART NO.	MFG./YEAR	MODEL & LOCATION	PART NO.
Drive Shaft (AWD) (Cont.)					
U-Joint (Cont.)					
2007-2005 All: [Type 15]					
	U-Joint (Frnt. Shaft; Frt.) [Ⓛ]	UJ445			
	<i>Brute Force Greaseable</i>	UJ225			
	Clamp Kit (Frnt. Shaft; Frt.)	UJ360-10			
	U-Joint (Rr. Shaft; Frt.) [Ⓢ]	UJ534G			
	<i>Brute Force Greaseable</i>	UJ235			
	<i>Brute Force Non Greaseable</i>	UJ234			
	Clamp Kit (Rr. Shaft; Frt.)	UJ530-10			
	U-Joint (Rr. Shaft; Rr.) [Ⓢ]	UJ534G			
	<i>Brute Force Greaseable</i>	UJ235			
	<i>Brute Force Non Greaseable</i>	UJ234			
	Clamp Kit (Rr. Shaft; Rr.)	UJ530-10			

Saturn CUV

Drive Shaft (AWD)					
U-Joint					
2007-2002 Vue: [Type 43]					
	U-Joint (Rr. Shaft; Ctr.) [Ⓛ]	UJ409			
	U-Joint (Rr. Shaft; Rr.) [Ⓢ]	UJ10439			

Subaru CUV Ascent, Forester

Drive Shaft (AWD)					
U-Joint					
2005-1998 Forester: [Type 41]					
	U-Joint (Rr. Shaft; Frt.) [Ⓛ]	[1] UJ10430			
	U-Joint (Rr. Shaft; Rr.) [Ⓢ]	[1] UJ10430			

Toyota CUV C-HR

Drive Shaft (AWD)					
U-Joint					
2007-2001 Highlander Exc. Hybrid Eng.: [Type 41]					
	U-Joint (Rr. Shaft; Frt.) [Ⓛ]	UJ10430			
	U-Joint (Rr. Shaft; Rr.) [Ⓢ]	UJ10430			
2001-1996 RAV4: [Type 41]					
	U-Joint (Rr. Shaft; Frt.) [Ⓛ]	UJ10430			
	U-Joint (Rr. Shaft; Rr.) [Ⓢ]	UJ10430			

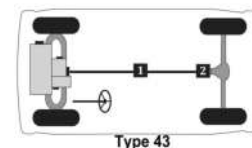
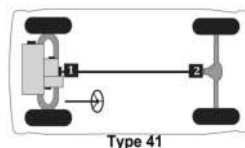
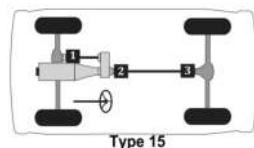

Passenger cars, light & medium trucks

Toyota Truck

MFG./YEAR	MODEL & LOCATION	PART NO.	MFG./YEAR	MODEL & LOCATION	PART NO.
Drive Shaft (2 W/D)			Drive Shaft (2 W/D) (Cont.)		
U-Joint			U-Joint (Cont.)		
2019-2008 Sequoia: [Type 1]			2019-1990 4Runner: [Type 1]		
	U-Joint (Front)❶	UJ331		U-Joint (Front)❶	UJ387
	Brute Force Greaseable	UJ232		Brute Force Greaseable	UJ285
	Brute Force Non Greaseable	UJ231		Brute Force Non Greaseable	UJ287
	(For Aluminum Drive Shaft)	UJ331C		U-Joint (Rear)❷	UJ387
	U-Joint (Rear)❷	UJ331		Brute Force Greaseable	UJ285
	Brute Force Greaseable	UJ232		Brute Force Non Greaseable	UJ287
	Brute Force Non Greaseable	UJ231		2014-2007 FJ Cruiser: [Type 1]	
	(For Aluminum Drive Shaft)	UJ331C		U-Joint (Front)❶	UJ387
	2019-2007 Tundra w/ 2 Joint Shaft: [Type 1]			Brute Force Greaseable	UJ285
	U-Joint (Front)❶	UJ331		Brute Force Non Greaseable	UJ287
	Brute Force Greaseable	UJ232		U-Joint (Rear)❷	UJ387
	Brute Force Non Greaseable	UJ231		Brute Force Greaseable	UJ285
	(For Aluminum Drive Shaft)	UJ331C		Brute Force Non Greaseable	UJ287
	U-Joint (Rear)❷	UJ331		2006-2005 Tundra: [Type 2]	
	Brute Force Greaseable	UJ232		U-Joint (Front)❶	UJ354
	Brute Force Non Greaseable	UJ231		Brute Force Greaseable	UJ270
	(For Aluminum Drive Shaft)	UJ331C		Brute Force Non Greaseable	UJ254
	2019-2007 Tundra w/ 3 Joint Shaft: [Type 2]			(For Aluminum Drive Shaft)	UJ354C
	U-Joint (Front)❶	UJ331		U-Joint (Center)❸	UJ354
	Brute Force Greaseable	UJ232		Brute Force Greaseable	UJ270
	Brute Force Non Greaseable	UJ231		Brute Force Non Greaseable	UJ254
	(For Aluminum Drive Shaft)	UJ331C		(For Aluminum Drive Shaft)	UJ354C
	U-Joint (Center)❸	UJ331		U-Joint (Rear)❷	UJ354
	Brute Force Greaseable	UJ232		Brute Force Greaseable	UJ270
	Brute Force Non Greaseable	UJ231		Brute Force Non Greaseable	UJ254
	(For Aluminum Drive Shaft)	UJ331C		(For Aluminum Drive Shaft)	UJ354C
	U-Joint (Rear)❷	UJ331		2004-2001 Sequoia: [Type 1]	
	Brute Force Greaseable	UJ232		U-Joint (Front)❶	UJ369
	Brute Force Non Greaseable	UJ231		Brute Force Greaseable	UJ280
	(For Aluminum Drive Shaft)	UJ331C		Brute Force Non Greaseable	UJ269
	2019-2005 Tacoma w/ 2 Joint Shaft: [Type 1]			(For Aluminum Drive Shaft)	UJ369C
	U-Joint (Front)❶	UJ354		U-Joint (Rear)❷	UJ369
	Brute Force Greaseable	UJ270		Brute Force Greaseable	UJ280
	Brute Force Non Greaseable	UJ254		Brute Force Non Greaseable	UJ269
	(For Aluminum Drive Shaft)	UJ354C		(For Aluminum Drive Shaft)	UJ369C
	U-Joint (Rear)❷	UJ354		2004-2001 Tacoma w/ Reg. Cab & Inner Lock	
	Brute Force Greaseable	UJ270		Rings: [Type 7]	
	Brute Force Non Greaseable	UJ254		U-Joint (Rear)❶	UJ387
	(For Aluminum Drive Shaft)	UJ354C		Brute Force Greaseable	UJ285
	2019-2005 Tacoma w/ 3 Joint Shaft: [Type 2]			Brute Force Non Greaseable	UJ287
	U-Joint (Front)❶	UJ354		2004-2001 Tacoma w/ Reg. Cab & Outer Lock	
	Brute Force Greaseable	UJ270		Rings: [Type 7]	
	Brute Force Non Greaseable	UJ254		U-Joint (Rear)❶	UJ369
	(For Aluminum Drive Shaft)	UJ354C		Brute Force Greaseable	UJ280
	U-Joint (Center)❸	UJ354		Brute Force Non Greaseable	UJ269
	Brute Force Greaseable	UJ270		(For Aluminum Drive Shaft)	UJ369C
	Brute Force Non Greaseable	UJ254			(Continued)
	(For Aluminum Drive Shaft)	UJ354C			
	U-Joint (Rear)❷	UJ354			
	Brute Force Greaseable	UJ270			
	Brute Force Non Greaseable	UJ254			
	(For Aluminum Drive Shaft)	UJ354C			

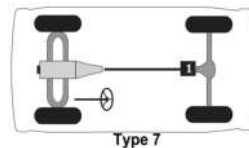
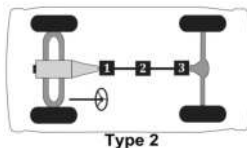
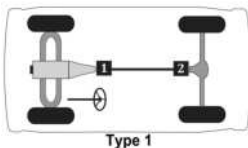

550 ▲ For Use w/ 1.063" Bearing Cap Application. ❶ For Use w/ 1.188" Bearing Cap Application. ❷ For Use w/ Inner Lock Ring Application on Half Shaft. ❸ For Use w/ Outer Lock Ring Application on Half Shaft.

MFG./YEAR	MODEL & LOCATION	PART NO.	MFG./YEAR	MODEL & LOCATION	PART NO.
Drive Shaft (2 W/D) (Cont.)			Drive Shaft (2 W/D) (Cont.)		
U-Joint (Cont.)			U-Joint (Cont.)		
2004-2001 Tacoma w/ Ext. Cab Exc. PreRunner & S-Runner: [Type 2]			2000-1999 Tacoma w/ Ext. Cab Exc. PreRunner: [Type 2]		
U-Joint (Front)ⓐ		UJ387	U-Joint (Front)ⓐ		UJ387
Brute Force Greaseable		UJ285	Brute Force Greaseable		UJ285
Brute Force Non Greaseable		UJ287	Brute Force Non Greaseable		UJ287
U-Joint (Center)ⓑ		UJ387	U-Joint (Center)ⓑ		UJ387
Brute Force Greaseable		UJ285	Brute Force Greaseable		UJ285
Brute Force Non Greaseable		UJ287	Brute Force Non Greaseable		UJ287
U-Joint (Rear)ⓐ		UJ387	U-Joint (Rear)ⓐ		UJ387
Brute Force Greaseable		UJ285	Brute Force Greaseable		UJ285
Brute Force Non Greaseable		UJ287	Brute Force Non Greaseable		UJ287
2004-2001 Tacoma PreRunner & S-Runner w/ Ext. Cab: [Type 1]			2000-1999 Tacoma PreRunner w/ Ext. Cab: [Type 1]		
U-Joint (Front)ⓐ		UJ387	U-Joint (Front)ⓐ		UJ387
Brute Force Greaseable		UJ285	Brute Force Greaseable		UJ285
Brute Force Non Greaseable		UJ287	Brute Force Non Greaseable		UJ287
U-Joint (Rear)ⓑ		UJ387	U-Joint (Rear)ⓑ		UJ387
Brute Force Greaseable		UJ285	Brute Force Greaseable		UJ285
Brute Force Non Greaseable		UJ287	Brute Force Non Greaseable		UJ287
2004-2001 Tacoma PreRunner & S-Runner w/ Crew Cab: [Type 1]			2000-1999 Tacoma w/ Reg. Cab & Outer Lock Rings Exc. PreRunner: [Type 1]		
U-Joint (Front)ⓐ		UJ387	U-Joint (Front)ⓐ		UJ369
Brute Force Greaseable		UJ285	Brute Force Greaseable		UJ280
Brute Force Non Greaseable		UJ287	Brute Force Non Greaseable		UJ269
U-Joint (Rear)ⓑ		UJ387	(For Aluminum Drive Shaft)		UJ369C
Brute Force Greaseable		UJ285	U-Joint (Rear)ⓑ		UJ369
Brute Force Non Greaseable		UJ287	Brute Force Greaseable		UJ280
2004-2000 Tundra: [Type 2]			Brute Force Non Greaseable		
U-Joint (Front)ⓐ		UJ369	(For Aluminum Drive Shaft)		UJ369C
Brute Force Greaseable		UJ280	U-Joint (Front)ⓐ		UJ369
Brute Force Non Greaseable		UJ269	Brute Force Greaseable		UJ280
(For Aluminum Drive Shaft)		UJ369C	Brute Force Non Greaseable		UJ269
U-Joint (Center)ⓑ		UJ369	(For Aluminum Drive Shaft)		UJ369C
Brute Force Greaseable		UJ280	U-Joint (Rear)ⓑ		UJ369
Brute Force Non Greaseable		UJ269	Brute Force Greaseable		UJ280
(For Aluminum Drive Shaft)		UJ369C	Brute Force Non Greaseable		UJ269
U-Joint (Rear)ⓐ		UJ369	(For Aluminum Drive Shaft)		UJ369C
Brute Force Greaseable		UJ280	1998 Tacoma w/ Reg. Cab & Inner Lock Rings: [Type 1]		
Brute Force Non Greaseable		UJ269	U-Joint (Front)ⓐ		UJ387
(For Aluminum Drive Shaft)		UJ369C	Brute Force Greaseable		UJ285
2000-1999 Tacoma w/ Reg. Cab & Inner Lock Rings Exc. PreRunner: [Type 1]			Brute Force Non Greaseable		UJ287
U-Joint (Front)ⓐ		UJ387	U-Joint (Rear)ⓑ		UJ387
Brute Force Greaseable		UJ285	Brute Force Greaseable		UJ285
Brute Force Non Greaseable		UJ287	Brute Force Non Greaseable		UJ287
U-Joint (Rear)ⓑ		UJ387	2000-1999 Tacoma PreRunner w/ Reg. Cab: [Type 7]		
Brute Force Greaseable		UJ285	U-Joint (Rear)ⓐ		UJ387
Brute Force Non Greaseable		UJ287	Brute Force Greaseable		UJ285
2000-1999 Tacoma PreRunner w/ Reg. Cab: [Type 7]			Brute Force Non Greaseable		UJ287
U-Joint (Rear)ⓐ		UJ387			
Brute Force Greaseable		UJ285			
Brute Force Non Greaseable		UJ287			

(Continued)

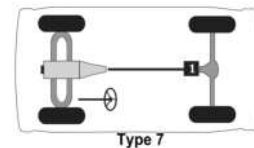
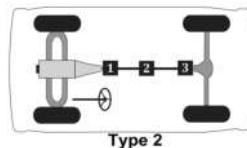
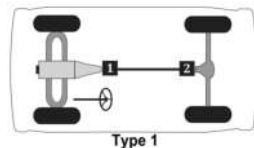

Passenger cars, light & medium trucks

Toyota Truck -- (Cont.)

MFG./YEAR	MODEL & LOCATION	PART NO.	MFG./YEAR	MODEL & LOCATION	PART NO.
Drive Shaft (2 W/D) (Cont.)			Drive Shaft (2 W/D) (Cont.)		
U-Joint (Cont.)			U-Joint (Cont.)		
1998	Tacoma w/ Ext. Cab Exc. PreRunner:		1997-1995	Tacoma w/ Ext. Cab: [Type 2]	
	[Type 2]		U-Joint (Front) ①		UJ387
	U-Joint (Front) ①	UJ387	<i>Brute Force Greaseable</i>		UJ285
	<i>Brute Force Greaseable</i>	UJ285	<i>Brute Force Non Greaseable</i>		UJ287
	<i>Brute Force Non Greaseable</i>	UJ287	U-Joint (Center) ②		UJ387
	U-Joint (Center) ②	UJ387	<i>Brute Force Greaseable</i>		UJ285
	<i>Brute Force Greaseable</i>	UJ285	<i>Brute Force Non Greaseable</i>		UJ287
	<i>Brute Force Non Greaseable</i>	UJ287	U-Joint (Rear) ③		UJ387
	U-Joint (Rear) ③	UJ387	<i>Brute Force Greaseable</i>		UJ285
	<i>Brute Force Greaseable</i>	UJ285	<i>Brute Force Non Greaseable</i>		UJ287
	<i>Brute Force Non Greaseable</i>	UJ287	1996-1993 T100 w/ Inner Lock Rings: [Type 2]		
1998	Tacoma PreRunner w/ Ext. Cab:		U-Joint (Front) ①		UJ387
	[Type 1]		<i>Brute Force Greaseable</i>		UJ285
	U-Joint (Front) ①	UJ387	<i>Brute Force Non Greaseable</i>		UJ287
	<i>Brute Force Greaseable</i>	UJ285	U-Joint (Center) ②		UJ387
	<i>Brute Force Non Greaseable</i>	UJ287	<i>Brute Force Greaseable</i>		UJ285
	U-Joint (Rear) ③	UJ387	<i>Brute Force Non Greaseable</i>		UJ287
	<i>Brute Force Greaseable</i>	UJ285	U-Joint (Rear) ③		UJ387
	<i>Brute Force Non Greaseable</i>	UJ287	<i>Brute Force Greaseable</i>		UJ285
	1998-1997 T100: [Type 2]		<i>Brute Force Non Greaseable</i>		UJ287
	U-Joint (Front) ①	UJ369	1996-1993 T100 w/ Outer Lock Rings: [Type 2]		
	<i>Brute Force Greaseable</i>	UJ280	U-Joint (Front) ①		UJ369
	<i>Brute Force Non Greaseable</i>	UJ269	<i>Brute Force Greaseable</i>		UJ280
	(For Aluminum Drive Shaft)	UJ369C	<i>Brute Force Non Greaseable</i>		UJ269
	U-Joint (Center) ②	UJ369	(For Aluminum Drive Shaft)		UJ369C
	<i>Brute Force Greaseable</i>	UJ280	U-Joint (Center) ②		UJ369
	<i>Brute Force Non Greaseable</i>	UJ269	<i>Brute Force Greaseable</i>		UJ280
	(For Aluminum Drive Shaft)	UJ369C	<i>Brute Force Non Greaseable</i>		UJ269
	U-Joint (Rear) ③	UJ369	(For Aluminum Drive Shaft)		UJ369C
	<i>Brute Force Greaseable</i>	UJ280	U-Joint (Rear) ③		UJ369
	<i>Brute Force Non Greaseable</i>	UJ269	<i>Brute Force Greaseable</i>		UJ280
	(For Aluminum Drive Shaft)	UJ369C	<i>Brute Force Non Greaseable</i>		UJ269
	1997-1995 Tacoma w/ Reg. Cab & Outer Lock Rings: [Type 1]		(For Aluminum Drive Shaft)		UJ369C
	U-Joint (Front) ①	UJ369	1995-1992 Pickup w/ 2 Joint Shaft & Inner Lock Rings: [Type 1]		
	<i>Brute Force Greaseable</i>	UJ280	U-Joint (Front) ①		UJ387
	<i>Brute Force Non Greaseable</i>	UJ269	<i>Brute Force Greaseable</i>		UJ285
	(For Aluminum Drive Shaft)	UJ369C	<i>Brute Force Non Greaseable</i>		UJ287
	U-Joint (Rear) ③	UJ369	U-Joint (Rear) ③		UJ387
	<i>Brute Force Greaseable</i>	UJ280	<i>Brute Force Greaseable</i>		UJ285
	<i>Brute Force Non Greaseable</i>	UJ269	<i>Brute Force Non Greaseable</i>		UJ287
	(For Aluminum Drive Shaft)	UJ369C	1995-1992 Pickup w/ 2 Joint Shaft & Outer Lock Rings: [Type 1]		
	1997-1995 Tacoma w/ Reg. Cab & Inner Lock Rings: [Type 1]		U-Joint (Front) ①		UJ369
	U-Joint (Front) ①	UJ387	<i>Brute Force Greaseable</i>		UJ280
	<i>Brute Force Greaseable</i>	UJ285	<i>Brute Force Non Greaseable</i>		UJ269
	<i>Brute Force Non Greaseable</i>	UJ287	(For Aluminum Drive Shaft)		UJ369C
	U-Joint (Rear) ③	UJ387	U-Joint (Rear) ③		UJ369
	<i>Brute Force Greaseable</i>	UJ285	<i>Brute Force Greaseable</i>		UJ280
	<i>Brute Force Non Greaseable</i>	UJ287	<i>Brute Force Non Greaseable</i>		UJ269
	(For Aluminum Drive Shaft)	UJ369C	(For Aluminum Drive Shaft)		UJ369C

(Continued)

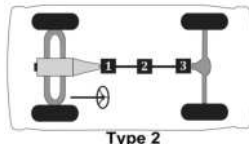
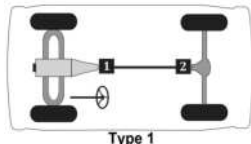

MFG./YEAR	MODEL & LOCATION	PART NO.	MFG./YEAR	MODEL & LOCATION	PART NO.
Drive Shaft (2 W/D) (Cont.)			Drive Shaft (2 W/D) (Cont.)		
U-Joint (Cont.)			U-Joint (Cont.)		
1995-1989 Pickup w/ 3 Joint Shaft: [Type 2]			1974-1969 Hi Lux: [Type 2]		
	U-Joint (Front)ⓐ	UJ387		U-Joint (Front)ⓐ	UJ390
	Brute Force Greaseable	UJ285		U-Joint (Center)ⓑ	UJ390
	Brute Force Non Greaseable	UJ287		U-Joint (Rear)ⓒ	UJ390
	U-Joint (Center)ⓑ	UJ387	Drive Shaft (4 W/D)		
	Brute Force Greaseable	UJ285	U-Joint		
	Brute Force Non Greaseable	UJ287	2020-2017 Land Cruiser:		
	U-Joint (Rear)ⓒ	UJ387		U-Joint (Frnt. Shaft; Frt.)	UJ389
	Brute Force Greaseable	UJ285		U-Joint (Frnt. Shaft; Rr.)	UJ389
	Brute Force Non Greaseable	UJ287		U-Joint (Rr. Shaft; Frt.)	UJ389
	U-Joint (Rear)ⓒ	UJ387		U-Joint (Rr. Shaft; Rr.)	UJ389
	Brute Force Greaseable	UJ285	2019-2016 Tacoma w/ 2 Joint Shaft:		
	Brute Force Non Greaseable	UJ287		U-Joint (Rr. Shaft; Frt.)	UJ331
	U-Joint (Front)ⓐ	UJ387		Brute Force Greaseable	UJ232
	Brute Force Greaseable	UJ285		Brute Force Non Greaseable	UJ231
	Brute Force Non Greaseable	UJ287		(For Aluminum Drive Shaft)	UJ331C
	U-Joint (Center)ⓑ	UJ387		U-Joint (Rr. Shaft; Rr.)	UJ331
	Brute Force Greaseable	UJ285		Brute Force Greaseable	UJ232
	Brute Force Non Greaseable	UJ287		Brute Force Non Greaseable	UJ231
	U-Joint (Rear)ⓒ	UJ387		(For Aluminum Drive Shaft)	UJ331C
	Brute Force Greaseable	UJ285	2019-2016 Tacoma w/ 3 Joint Shaft:		
	Brute Force Non Greaseable	UJ287		U-Joint (Rr. Shaft; Frt.)	UJ331
	1988-1984 Pickup w/ 2 Joint Shaft & 4 Speed			Brute Force Greaseable	UJ232
	Man. Trans.: [Type 1]			Brute Force Non Greaseable	UJ231
	U-Joint (Front)ⓐ	UJ390		(For Aluminum Drive Shaft)	UJ331C
	U-Joint (Rear)ⓑ	UJ390		U-Joint (Rr. Shaft; Ctr.)	UJ331
	1988-1984 Pickup w/ 3 Joint Shaft & 4 Speed			Brute Force Greaseable	UJ232
	Man. Trans.: [Type 2]			Brute Force Non Greaseable	UJ231
	U-Joint (Front)ⓐ	UJ390		(For Aluminum Drive Shaft)	UJ331C
	U-Joint (Center)ⓑ	UJ390		U-Joint (Rr. Shaft; Rr.)	UJ331
	U-Joint (Rear)ⓒ	UJ390		Brute Force Greaseable	UJ232
	1988-1984 Pickup w/ 2 Joint Shaft Exc. 4 Spd.			Brute Force Non Greaseable	UJ231
	Man. Trans.: [Type 1]			(For Aluminum Drive Shaft)	UJ331C
	U-Joint (Front)ⓐ	UJ387	2019-2008 Sequoia: [Type 13]		
	Brute Force Greaseable	UJ285		U-Joint (Frnt. Shaft; Frt.)ⓐ	UJ354
	Brute Force Non Greaseable	UJ287		Brute Force Greaseable	UJ270
	U-Joint (Rear)ⓑ	UJ387		Brute Force Non Greaseable	UJ254
	Brute Force Greaseable	UJ285		(For Aluminum Drive Shaft)	UJ354C
	Brute Force Non Greaseable	UJ287		U-Joint (Frnt. Shaft; Rr.)ⓑ	UJ354
	1988-1984 Pickup w/ 3 Joint Shaft Exc. 4 Spd.			Brute Force Greaseable	UJ270
	Man. Trans.: [Type 2]			Brute Force Non Greaseable	UJ254
	U-Joint (Front)ⓐ	UJ387		(For Aluminum Drive Shaft)	UJ354C
	Brute Force Greaseable	UJ285		U-Joint (Rr. Shaft; Frt.)ⓒ	UJ331
	Brute Force Non Greaseable	UJ287		Brute Force Greaseable	UJ232
	U-Joint (Center)ⓑ	UJ387		Brute Force Non Greaseable	UJ231
	Brute Force Greaseable	UJ285		(For Aluminum Drive Shaft)	UJ331C
	Brute Force Non Greaseable	UJ287		U-Joint (Rr. Shaft; Rr.)ⓑ	UJ331
	U-Joint (Rear)ⓒ	UJ387		Brute Force Greaseable	UJ232
	Brute Force Greaseable	UJ285		Brute Force Non Greaseable	UJ231
	Brute Force Non Greaseable	UJ287		(For Aluminum Drive Shaft)	UJ331C
	1983-1979 Pickup w/ 2 Joint Shaft: [Type 1]			U-Joint (Rr. Shaft; Rr.)ⓑ	UJ331
	U-Joint (Front)ⓐ	UJ390		Brute Force Greaseable	UJ232
	U-Joint (Rear)ⓑ	UJ390		Brute Force Non Greaseable	UJ231
	1983-1979 Pickup w/ 3 Joint Shaft: [Type 2]			(For Aluminum Drive Shaft)	UJ331C
	U-Joint (Front)ⓐ	UJ390			
	U-Joint (Center)ⓑ	UJ390			
	U-Joint (Rear)ⓒ	UJ390			

(Continued)

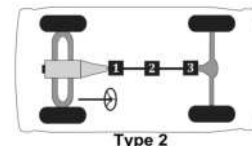
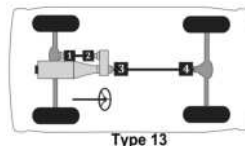
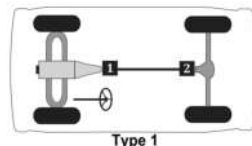

Passenger cars, light & medium trucks

Toyota Truck -- (Cont.)

MFG./YEAR	MODEL & LOCATION	PART NO.	MFG./YEAR	MODEL & LOCATION	PART NO.
Drive Shaft (4 W/D) (Cont.)			Drive Shaft (4 W/D) (Cont.)		
U-Joint (Cont.)			U-Joint (Cont.)		
2019-2007 Tundra w/ 2 Joint Shaft: [Type 13]			2016-2013 Land Cruiser: [Type 13]		
	U-Joint (Frnt. Shaft; Frnt.) [Ⓚ]	UJ354		U-Joint (Frnt. Shaft; Frnt.) [Ⓚ]	UJ387
	Brute Force Greaseable	UJ270		Brute Force Greaseable	UJ285
	Brute Force Non Greaseable	UJ254		Brute Force Non Greaseable	UJ287
	(For Aluminum Drive Shaft)	UJ354C		U-Joint (Frnt. Shaft; Rr.) [Ⓚ]	UJ387
	U-Joint (Frnt. Shaft; Rr.) [Ⓚ]	UJ354		Brute Force Greaseable	UJ285
	Brute Force Greaseable	UJ270		Brute Force Non Greaseable	UJ287
	Brute Force Non Greaseable	UJ254		U-Joint (Rr. Shaft; Frnt.) [Ⓚ]	UJ387
	(For Aluminum Drive Shaft)	UJ354C		Brute Force Greaseable	UJ285
	U-Joint (Rr. Shaft; Frnt.) [Ⓚ]	UJ331		Brute Force Non Greaseable	UJ287
	Brute Force Greaseable	UJ232		U-Joint (Rr. Shaft; Rr.) [Ⓚ]	UJ387
	Brute Force Non Greaseable	UJ231		Brute Force Greaseable	UJ285
	(For Aluminum Drive Shaft)	UJ331C		Brute Force Non Greaseable	UJ287
	U-Joint (Rr. Shaft; Rr.) [Ⓚ]	UJ331		2015-2005 Tacoma w/ 2 Joint Shaft: [Type 17]	
	Brute Force Greaseable	UJ232		U-Joint (Rr. Shaft; Frnt.) [Ⓚ]	UJ354
	Brute Force Non Greaseable	UJ231		Brute Force Greaseable	UJ270
	(For Aluminum Drive Shaft)	UJ331C		Brute Force Non Greaseable	UJ254
	2019-2007 Tundra w/ 3 Joint Shaft: [Type 14]			(For Aluminum Drive Shaft)	UJ354C
	U-Joint (Frnt. Shaft; Frnt.) [Ⓚ]	UJ354		U-Bolt Kit (Rr. Shaft; Frnt.)	[1] UJ329-10
	Brute Force Greaseable	UJ270		U-Joint (Rr. Shaft; Rr.) [Ⓚ]	UJ354
	Brute Force Non Greaseable	UJ254		Brute Force Greaseable	UJ270
	(For Aluminum Drive Shaft)	UJ354C		Brute Force Non Greaseable	UJ254
	U-Joint (Frnt. Shaft; Rr.) [Ⓚ]	UJ354		(For Aluminum Drive Shaft)	UJ354C
	Brute Force Greaseable	UJ270		U-Bolt Kit (Rr. Shaft; Rr.)	[1] UJ329-10
	Brute Force Non Greaseable	UJ254		2015-2005 Tacoma w/ 3 Joint Shaft: [Type 18]	
	(For Aluminum Drive Shaft)	UJ354C		U-Joint (Rr. Shaft; Frnt.) [Ⓚ]	UJ354
	U-Joint (Rr. Shaft; Frnt.) [Ⓚ]	UJ331		Brute Force Greaseable	UJ270
	Brute Force Greaseable	UJ232		Brute Force Non Greaseable	UJ254
	Brute Force Non Greaseable	UJ231		(For Aluminum Drive Shaft)	UJ354C
	(For Aluminum Drive Shaft)	UJ331C		U-Bolt Kit (Rr. Shaft; Frnt.)	[1] UJ329-10
	U-Joint (Rr. Shaft; Ctr.) [Ⓚ]	UJ331		U-Joint (Rr. Shaft; Ctr.) [Ⓚ]	UJ354
	Brute Force Greaseable	UJ232		Brute Force Greaseable	UJ270
	Brute Force Non Greaseable	UJ231		Brute Force Non Greaseable	UJ254
	(For Aluminum Drive Shaft)	UJ331C		(For Aluminum Drive Shaft)	UJ354C
	U-Joint (Rr. Shaft; Rr.) [Ⓚ]	UJ331		U-Bolt Kit (Rr. Shaft; Ctr.)	[1] UJ329-10
	Brute Force Greaseable	UJ232		U-Joint (Rr. Shaft; Rr.) [Ⓚ]	UJ354
	Brute Force Non Greaseable	UJ231		Brute Force Greaseable	UJ270
	(For Aluminum Drive Shaft)	UJ331C		Brute Force Non Greaseable	UJ254
	2019-1996 4Runner: [Type 13]			(For Aluminum Drive Shaft)	UJ354C
	U-Joint (Frnt. Shaft; Frnt.) [Ⓚ]	UJ387		U-Bolt Kit (Rr. Shaft; Rr.)	[1] UJ329-10
	Brute Force Greaseable	UJ285		U-Joint (Rr. Shaft; Rr.) [Ⓚ]	UJ354
	Brute Force Non Greaseable	UJ287		Brute Force Greaseable	UJ270
	U-Joint (Frnt. Shaft; Rr.) [Ⓚ]	UJ387		Brute Force Non Greaseable	UJ254
	Brute Force Greaseable	UJ285		(For Aluminum Drive Shaft)	UJ354C
	Brute Force Non Greaseable	UJ287		U-Joint (Rr. Shaft; Rr.)	[1] UJ329-10
	U-Joint (Rr. Shaft; Frnt.) [Ⓚ]	UJ387			(Continued)
	Brute Force Greaseable	UJ285			
	Brute Force Non Greaseable	UJ287			
	U-Joint (Rr. Shaft; Rr.) [Ⓚ]	UJ387			
	Brute Force Greaseable	UJ285			
	Brute Force Non Greaseable	UJ287			
	U-Joint (Rr. Shaft; Rr.) [Ⓚ]	UJ387			
	Brute Force Greaseable	UJ285			
	Brute Force Non Greaseable	UJ287			

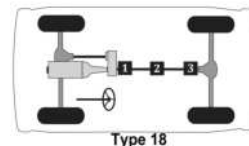
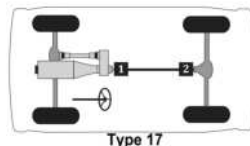
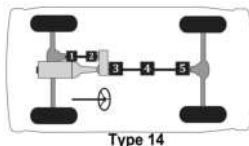
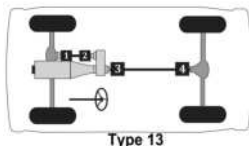

554 ▲ For Use w/ 1.063" Bearing Cap Application. Ⓚ For Use w/ 1.188" Bearing Cap Application. ◇ For Use w/ Inner Lock Ring Application on Half Shaft. □ For Use w/ Outer Lock Ring Application on Half Shaft.

MFG./YEAR	MODEL & LOCATION	PART NO.	MFG./YEAR	MODEL & LOCATION	PART NO.
Drive Shaft (4 W/D) (Cont.)			Drive Shaft (4 W/D) (Cont.)		
U-Joint (Cont.)			U-Joint (Cont.)		
2014-2007 FJ Cruiser: [Type 13]			2004-2001 Sequoia: [Type 13]		
	U-Joint (Frnt. Shaft; Frt.) ^①	UJ387		U-Joint (Frnt. Shaft; Frt.) ^①	UJ369
	Brute Force Greaseable	UJ285		Brute Force Greaseable	UJ280
	Brute Force Non Greaseable	UJ287		Brute Force Non Greaseable	UJ269
	U-Joint (Frnt. Shaft; Rr.) ^②	UJ387		(For Aluminum Drive Shaft)	UJ369C
	Brute Force Greaseable	UJ285		U-Joint (Frnt. Shaft; Rr.) ^②	UJ369
	Brute Force Non Greaseable	UJ287		Brute Force Greaseable	UJ280
	U-Joint (Rr. Shaft; Frt.) ^③	UJ387		Brute Force Non Greaseable	UJ269
	Brute Force Greaseable	UJ285		(For Aluminum Drive Shaft)	UJ369C
	Brute Force Non Greaseable	UJ287		U-Joint (Rr. Shaft; Frt.) ^③	UJ387
	U-Joint (Rr. Shaft; Rr.) ^④	UJ387		Brute Force Greaseable	UJ285
	Brute Force Greaseable	UJ285		Brute Force Non Greaseable	UJ287
	Brute Force Non Greaseable	UJ287		U-Joint (Rr. Shaft; Rr.) ^④	UJ387
	2011-2003 Land Cruiser: [Type 13]			Brute Force Greaseable	UJ285
	U-Joint (Frnt. Shaft; Frt.) ^①	UJ387		Brute Force Non Greaseable	UJ287
	Brute Force Greaseable	UJ285		2004-1995 Tacoma: [Type 13]	
	Brute Force Non Greaseable	UJ287		U-Joint (Frnt. Shaft; Frt.) ^①	UJ387
	U-Joint (Frnt. Shaft; Rr.) ^②	UJ387		Brute Force Greaseable	UJ285
	Brute Force Greaseable	UJ285		Brute Force Non Greaseable	UJ287
	Brute Force Non Greaseable	UJ287		U-Joint (Frnt. Shaft; Rr.) ^②	UJ387
	U-Joint (Rr. Shaft; Frt.) ^③	UJ387		Brute Force Greaseable	UJ285
	Brute Force Greaseable	UJ285		Brute Force Non Greaseable	UJ287
	Brute Force Non Greaseable	UJ287		U-Joint (Rr. Shaft; Frt.) ^③	UJ387
	U-Joint (Rr. Shaft; Rr.) ^④	UJ387		Brute Force Greaseable	UJ285
	Brute Force Greaseable	UJ285		Brute Force Non Greaseable	UJ287
	Brute Force Non Greaseable	UJ287		U-Joint (Rr. Shaft; Rr.) ^④	UJ387
	2007-2005 Sequoia: [Type 17]			Brute Force Greaseable	UJ285
	U-Joint (Rr. Shaft; Frt.) ^①	UJ389		Brute Force Non Greaseable	UJ287
	U-Joint (Rr. Shaft; Rr.) ^②	UJ389		2002-1998 Land Cruiser: [Type 17]	
	2006-2000 Tundra: [Type 13]			U-Joint (Rr. Shaft; Frt.) ^①	UJ387
	U-Joint (Frnt. Shaft; Frt.) ^①	UJ369		Brute Force Greaseable	UJ285
	Brute Force Greaseable	UJ280		Brute Force Non Greaseable	UJ287
	Brute Force Non Greaseable	UJ269		U-Joint (Rr. Shaft; Rr.) ^②	UJ387
	(For Aluminum Drive Shaft)	UJ369C		Brute Force Greaseable	UJ285
	U-Joint (Frnt. Shaft; Rr.) ^②	UJ369		Brute Force Non Greaseable	UJ287
	Brute Force Greaseable	UJ280		1998-1993 T100: [Type 15]	
	Brute Force Non Greaseable	UJ269		U-Joint (Frnt. Shaft; Frt.) ^①	UJ387
	(For Aluminum Drive Shaft)	UJ369C		Brute Force Greaseable	UJ285
	U-Joint (Rr. Shaft; Frt.) ^③	UJ387		Brute Force Non Greaseable	UJ287
	Brute Force Greaseable	UJ285		U-Joint (Rr. Shaft; Frt.) ^②	UJ387
	Brute Force Non Greaseable	UJ287		Brute Force Greaseable	UJ285
	U-Joint (Rr. Shaft; Rr.) ^④	UJ387		Brute Force Non Greaseable	UJ287
	Brute Force Greaseable	UJ285		U-Joint (Rr. Shaft; Rr.) ^③	UJ387
	Brute Force Non Greaseable	UJ287		Brute Force Greaseable	UJ285
				Brute Force Non Greaseable	UJ287
				U-Joint (Rr. Shaft; Rr.) ^④	UJ387
				Brute Force Greaseable	UJ285
				Brute Force Non Greaseable	UJ287

(Continued)

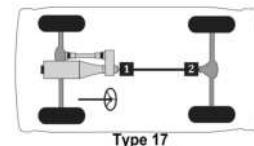
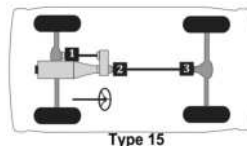
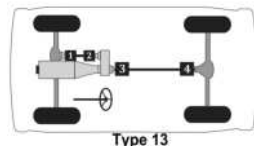

Passenger cars, light & medium trucks

Toyota Truck -- (Cont.)

MFG./YEAR	MODEL & LOCATION	PART NO.	MFG./YEAR	MODEL & LOCATION	PART NO.
Drive Shaft (4 W/D) (Cont.)			Drive Shaft (4 W/D) (Cont.)		
U-Joint (Cont.)			U-Joint (Cont.)		
1997-1991 Land Cruiser: [Type 13]			1988-1986 Pickup: [Type 13]		
	U-Joint (Fr. Shaft; Frt.)ⓐ	UJ387		U-Joint (Fr. Shaft; Frt.)ⓐ	UJ387
	Brute Force Greaseable	UJ285		Brute Force Greaseable	UJ285
	Brute Force Non Greaseable	UJ287		Brute Force Non Greaseable	UJ287
	U-Joint (Fr. Shaft; Rr.)ⓑ	UJ387		U-Joint (Fr. Shaft; Rr.)ⓑ	[2] UJ513
	Brute Force Greaseable	UJ285		U-Joint (Rr. Shaft; Frt.)ⓐ	UJ387
	Brute Force Non Greaseable	UJ287		Brute Force Greaseable	UJ285
	U-Joint (Rr. Shaft; Frt.)ⓐ	UJ389		Brute Force Non Greaseable	UJ287
	U-Joint (Rr. Shaft; Rr.)ⓑ	UJ389		U-Joint (Rr. Shaft; Rr.)ⓑ	UJ387
				Brute Force Greaseable	UJ285
	1995-1989 Pickup w/ 2 Joint Shaft: [Type 13]			Brute Force Non Greaseable	UJ287
	U-Joint (Fr. Shaft; Frt.)ⓐ	UJ387		Centering Ball Kit	UJ614
	Brute Force Greaseable	UJ285		1985 Pickup w/ CV Front Shaft & 2 Joint	
	Brute Force Non Greaseable	UJ287		Rear Shaft: [Type 13]	
	U-Joint (Fr. Shaft; Rr.)ⓑ	[2] UJ513		U-Joint (Fr. Shaft; Frt.)ⓐ	UJ387
	U-Joint (Rr. Shaft; Frt.)ⓐ	UJ387		Brute Force Greaseable	UJ285
	Brute Force Greaseable	UJ285		Brute Force Non Greaseable	UJ287
	Brute Force Non Greaseable	UJ287		U-Joint (Fr. Shaft; Rr.)ⓑ	[2] UJ513
	U-Joint (Rr. Shaft; Rr.)ⓑ	UJ387		U-Joint (Rr. Shaft; Frt.)ⓐ	UJ387
	Brute Force Greaseable	UJ285		Brute Force Greaseable	UJ285
	Brute Force Non Greaseable	UJ287		Brute Force Non Greaseable	UJ287
	Centering Ball Kit	UJ614		Centering Ball Kit	UJ614
	1995-1989 Pickup w/ 3 Joint Shaft: [Type 14]			1985 Pickup w/ CV Front Shaft & 3 Joint	
	U-Joint (Fr. Shaft; Frt.)ⓐ	UJ387		Rear Shaft: [Type 14]	
	Brute Force Greaseable	UJ285		U-Joint (Fr. Shaft; Frt.)ⓐ	UJ387
	Brute Force Non Greaseable	UJ287		Brute Force Greaseable	UJ285
	U-Joint (Fr. Shaft; Rr.)ⓑ	[2] UJ513		Brute Force Non Greaseable	UJ287
	U-Joint (Rr. Shaft; Frt.)ⓐ	UJ387		U-Joint (Fr. Shaft; Rr.)ⓑ	[2] UJ513
	Brute Force Greaseable	UJ285		U-Joint (Rr. Shaft; Frt.)ⓐ	UJ387
	Brute Force Non Greaseable	UJ287		Brute Force Greaseable	UJ285
	Centering Ball Kit	UJ614		Brute Force Non Greaseable	UJ287
	1995-1984 4Runner: [Type 13]			U-Joint (Rr. Shaft; Ctr.)ⓐ	UJ387
	U-Joint (Fr. Shaft; Frt.)ⓐ	UJ387		Brute Force Greaseable	UJ285
	Brute Force Greaseable	UJ285		Brute Force Non Greaseable	UJ287
	Brute Force Non Greaseable	UJ287		U-Joint (Rr. Shaft; Rr.)ⓑ	UJ387
	U-Joint (Fr. Shaft; Rr.)ⓑ	[2] UJ513		Brute Force Greaseable	UJ285
	U-Joint (Rr. Shaft; Frt.)ⓐ	UJ387		Brute Force Non Greaseable	UJ287
	Brute Force Greaseable	UJ285		Centering Ball Kit	UJ614
	Brute Force Non Greaseable	UJ287			
	U-Joint (Rr. Shaft; Rr.)ⓑ	UJ387			
	Brute Force Greaseable	UJ285			
	Brute Force Non Greaseable	UJ287			
	Centering Ball Kit	UJ614			
	1990-1974 Land Cruiser: [Type 13]				
	U-Joint (Fr. Shaft; Frt.)ⓐ	UJ389			
	U-Joint (Fr. Shaft; Rr.)ⓑ	UJ389			
	U-Joint (Rr. Shaft; Frt.)ⓐ	UJ389			
	U-Joint (Rr. Shaft; Rr.)ⓑ	UJ389			

(Continued)

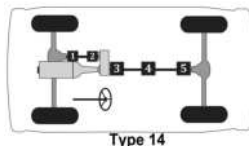
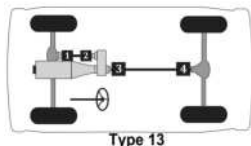

556 ▲ For Use w/ 1.063" Bearing Cap Application. ⓐ For Use w/ 1.188" Bearing Cap Application. ◇ For Use w/ Inner Lock Ring Application on Half Shaft. □ For Use w/ Outer Lock Ring Application on Half Shaft.

MFG./YEAR	MODEL & LOCATION	PART NO.	MFG./YEAR	MODEL & LOCATION	PART NO.
Drive Shaft (4 W/D) (Cont.)			Drive Shaft (4 W/D) (Cont.)		
U-Joint (Cont.)			U-Joint (Cont.)		
1985	Pickup w/ 2 Joint Front & Rear Shafts:		1984-1979	Pickup w/ CV Front Shaft & 3 Joint	
	[Type 13]			Rear Shaft: [Type 14]	
	U-Joint (Fr. Shaft; Frt.)①	UJ387		U-Joint (Fr. Shaft; Frt.)①	UJ387
	Brute Force Greaseable	UJ285		Brute Force Greaseable	UJ285
	Brute Force Non Greaseable	UJ287		Brute Force Non Greaseable	UJ287
	U-Joint (Fr. Shaft; Rr.)②	UJ387		U-Joint (Fr. Shaft; Rr.)②	UJ513 [2]
	Brute Force Greaseable	UJ285		U-Joint (Rr. Shaft; Frt.)③	UJ387
	Brute Force Non Greaseable	UJ287		Brute Force Greaseable	UJ285
	U-Joint (Rr. Shaft; Frt.)③	UJ387		Brute Force Non Greaseable	UJ287
	Brute Force Greaseable	UJ285		U-Joint (Rr. Shaft; Ctr.)④	UJ387
	Brute Force Non Greaseable	UJ287		Brute Force Greaseable	UJ285
	U-Joint (Rr. Shaft; Rr.)④	UJ387		Brute Force Non Greaseable	UJ287
	Brute Force Greaseable	UJ285		U-Joint (Rr. Shaft; Rr.)⑤	UJ387
	Brute Force Non Greaseable	UJ287		Brute Force Greaseable	UJ285
	Centering Ball Kit	UJ614		Brute Force Non Greaseable	UJ287
1985	Pickup w/ 2 Joint Front Shaft & 3 Joint			Centering Ball Kit	UJ613
	Rear Shaft: [Type 14]		1984-1979	Pickup w/ 2 Joint Front & Rear Shafts:	
	U-Joint (Fr. Shaft; Frt.)①	UJ387		[Type 13]	
	Brute Force Greaseable	UJ285		U-Joint (Fr. Shaft; Frt.)①	UJ387
	Brute Force Non Greaseable	UJ287		Brute Force Greaseable	UJ285
	U-Joint (Fr. Shaft; Rr.)②	UJ387		Brute Force Non Greaseable	UJ287
	Brute Force Greaseable	UJ285		U-Joint (Fr. Shaft; Rr.)②	UJ387
	Brute Force Non Greaseable	UJ287		Brute Force Greaseable	UJ285
	U-Joint (Rr. Shaft; Frt.)③	UJ387		Brute Force Non Greaseable	UJ287
	Brute Force Greaseable	UJ285		U-Joint (Rr. Shaft; Frt.)③	UJ387
	Brute Force Non Greaseable	UJ287		Brute Force Greaseable	UJ285
	U-Joint (Rr. Shaft; Ctr.)④	UJ387		Brute Force Non Greaseable	UJ287
	Brute Force Greaseable	UJ285		U-Joint (Rr. Shaft; Rr.)④	UJ387
	Brute Force Non Greaseable	UJ287		Brute Force Greaseable	UJ285
	U-Joint (Rr. Shaft; Rr.)⑤	UJ387		Brute Force Non Greaseable	UJ287
	Brute Force Greaseable	UJ285		Centering Ball Kit	UJ613
	Brute Force Non Greaseable	UJ287	1984-1979	Pickup w/ 2 Joint Front Shaft & 3 Joint	
	Centering Ball Kit	UJ614		Rear Shaft: [Type 14]	
1984-1979	Pickup w/ CV Front Shaft & 2 Joint			U-Joint (Fr. Shaft; Frt.)①	UJ387
	Rear Shaft: [Type 13]			Brute Force Greaseable	UJ285
	U-Joint (Fr. Shaft; Frt.)①	UJ387		Brute Force Non Greaseable	UJ287
	Brute Force Greaseable	UJ285		U-Joint (Fr. Shaft; Rr.)②	UJ387
	Brute Force Non Greaseable	UJ287		Brute Force Greaseable	UJ285
	U-Joint (Fr. Shaft; Rr.)②	UJ513 [2]		Brute Force Non Greaseable	UJ287
	U-Joint (Rr. Shaft; Frt.)③	UJ387		U-Joint (Rr. Shaft; Frt.)③	UJ387
	Brute Force Greaseable	UJ285		Brute Force Greaseable	UJ285
	Brute Force Non Greaseable	UJ287		Brute Force Non Greaseable	UJ287
	U-Joint (Rr. Shaft; Rr.)④	UJ387		U-Joint (Rr. Shaft; Ctr.)④	UJ387
	Brute Force Greaseable	UJ285		Brute Force Greaseable	UJ285
	Brute Force Non Greaseable	UJ287		Brute Force Non Greaseable	UJ287
	Centering Ball Kit	UJ613		U-Joint (Rr. Shaft; Rr.)⑤	UJ387
				Brute Force Greaseable	UJ285
				Brute Force Non Greaseable	UJ287
				Centering Ball Kit	UJ613
			1973-1965	Land Cruiser: [Type 13]	
				U-Joint (Fr. Shaft; Frt.)①	UJ396
				U-Joint (Fr. Shaft; Rr.)②	UJ396
				U-Joint (Rr. Shaft; Frt.)③	UJ396
				U-Joint (Rr. Shaft; Rr.)④	UJ396
				U-Joint (PTO)	UJ396

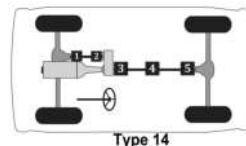
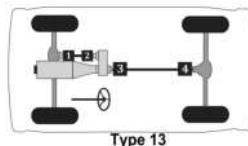

Passenger cars, light & medium trucks

Volkswagen CUV

MFG./YEAR	MODEL & LOCATION	PART NO.	MFG./YEAR	MODEL & LOCATION	PART NO.
Drive Shaft					
U-Joint					
2021-2018 Atlas:					
	Flex Coupler	VKJF98040			
2021-2018 Tiguan:					
	Flex Coupler	VKJF98040			
2014-2004 Touareg:					
	Flex Coupler	VKJF98038			

Passenger car, light and medium duty truck U-Joints

Double cardan CV parts



Ball Seat Repair Kit

Ball seat repair kit	Series
UJ606	Saginaw



Flange Yoke - Early

Flange yoke earlier design	Flange face to CL	Bolt circles	Series	Pilot diameter
UJ627	1.62"	3.50"	1310	2.00"



Centering Yoke

Centering yokes	Between tabs	Bolt hole spacing length	Bolt hole spacing width	Series	Stud socket dimension
UJ607	3.22"	1.500"	2.34"	1310HR	0.500
UJ608	3.62"	1.500"	2.88"	1330HR	0.500



Flange Yoke - Later

Flange yoke later design	Yoke hole	Flange face to CL	Bolt circles	Series	Pilot diameter
UJ628C	1.063"	1.62"	4.25"	1330	3.12"
UJ628F	1.063"	1.62"	4.25"	1330	2.00"
UJ630F	1.188"	1.62"	4.25"	1350	2.00"



Centering Ball Kits

Centering ball kits	Ball diameter	Stud bore diameter	Series
UJ612	1.12"	0.5	Spicer Early Design
UJ613	1.34"	0.47	Toyota
UJ614	1.46"	0.51	Toyota
UJ617	1.12"	0.5	Spicer Later Design



Ball Stud Tube Weld Yoke

Ball stud tube weld yokes	Ball stud diameter	Ball stud length	Series	Center line to end of ball stud
UJ633	0.50"	0.60"	1310	1.64"
UJ638	0.50"	0.60"	1330	1.66"



Flange Yoke

Flange yoke	Flange face to CL	Bolt circles	Series	Pilot diameter
UJ626	1.69"	4.25"	3R	3.12"



H Yokes

H yokes	Center to center	Maximum joint angle	Series
UJ646	3.25"	17	3R
UJ647	2.69"	26	1310
UJ648	2.75"	18	1330
UJ650	2.88"	30	1350

Double cardan CV parts



Grease fittings

Grease fittings (sold in multiples of 10)	Type	Spec
UJ621	Flush	1/4 Inch-28 (.366 Overall Length)
UJ621B	Flush	M5 x 0.8 (.314 Overall Length)



Grease fittings

Grease fittings (sold in multiples of 10)	Type	Spec
UJ622	Extended Length Regular	1/4 Inch-28 (1.65 Overall Length)



Clamp kits

Clamp kits (sold in multiples of 10)	Type	Spec
UJ3415	Stainless Steel CV Clamp	365 MM in Length
UJ3416	Stainless Steel CV Clamp	750 MM in Length



Lock plate w/cap screw kits

4 Welded plate type round bearings

Standard U-Joint	Lock plate w/cap screws (Kit)
UJ333	UJ12858
UJ334	UJ12859
UJ376	UJ12859
UJ381	UJ12859

2 Welded plate type & 2 Plain round bearings

Standard U-Joint	Lock plate w/cap screws (Kit)
UJ475	UJ12858*
UJ476	UJ12859**
UJ477	UJ12859**
UJ478	UJ12859**

* Kit contents for UJ12858: Lockplate Qty. 4 (334LP) & Screws Qty. 8 (334CS)

** Kit contents for UJ12859: Lockplate Qty. 4 (334LP) & Screws Qty. 8 (333CS)

Components not sold separately

Passenger car, light and medium duty truck U-Joints

Universal joint kit and hardware listing

Standard Universal Joint part numbers with optional versions and associated hardware

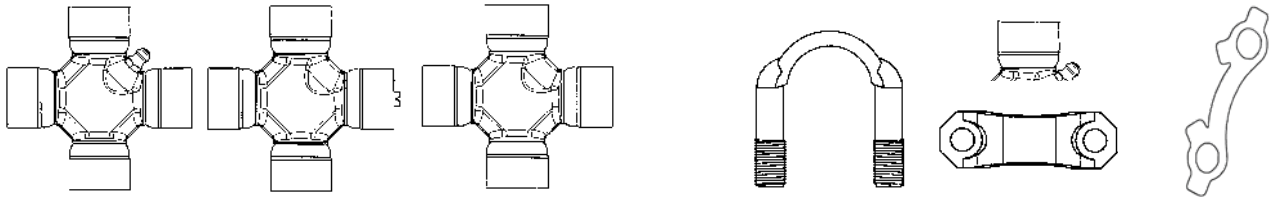

Standard U-Joint	Brute Force Greaseable	Brute Force Non Greaseable	Aluminum Drive Shaft	U Bolt Kit	Clamp Kit	Lock Plate with screws
UJ315G	UJ246	N/A	N/A	N/A	UJ318-10	
UJ316	UJ248	N/A	N/A	N/A	UJ316-10	
UJ317	UJ246	N/A	N/A	N/A	UJ318-10	
UJ319	N/A	N/A	N/A	N/A	UJ318-10	
UJ330	UJ295	N/A	UJ330C	UJ330-10	UJ331-10 or UJ492-10	
UJ330A	UJ295A	N/A	N/A	N/A	N/A	
UJ331	UJ232	UJ231	UJ331C	UJ330-10	UJ331-10	
UJ331A	UJ232A	N/A	N/A	N/A	N/A	
UJ347	N/A	UJ347BF	N/A	N/A	N/A	
UJ351	N/A	UJ351BF	UJ351C	UJ358-10	UJ351-10 or UJ352-10	
UJ351A	N/A	UJ351ABF	UJ351C	UJ358-10	UJ351-10 or UJ352-10	
UJ353	UJ275	N/A	N/A	UJ329-10	N/A	
UJ354	UJ270	UJ254	UJ354C	UJ329-10	UJ360-10 or UJ437-10	
UJ355	UJ290	N/A	UJ355C	N/A	UJ530-10	
UJ358	N/A	UJ358BF	N/A	UJ358-10	UJ351-10	
UJ358A	N/A	UJ358ABF	N/A	UJ358-10	UJ351-10	
UJ361	N/A	N/A	N/A	UJ329-10	N/A	
UJ365*	UJ378	UJ365	N/A	N/A	N/A	
UJ368	N/A	N/A	N/A	N/A	UJ360-10	
UJ369	UJ280	UJ269	UJ369C	UJ329-10	UJ360-10 or UJ437-10	
UJ371*	UJ377	UJ371	N/A	N/A	N/A	
UJ372	N/A	N/A	UJ372C	N/A	UJ530-10	
UJ374	N/A	UJ374BF	N/A	N/A	N/A	

(Continued)

* Standard part is Brute Force

N/A Not Available

Universal joint kit and hardware listing

Standard Universal Joint part numbers with optional versions and associated hardware

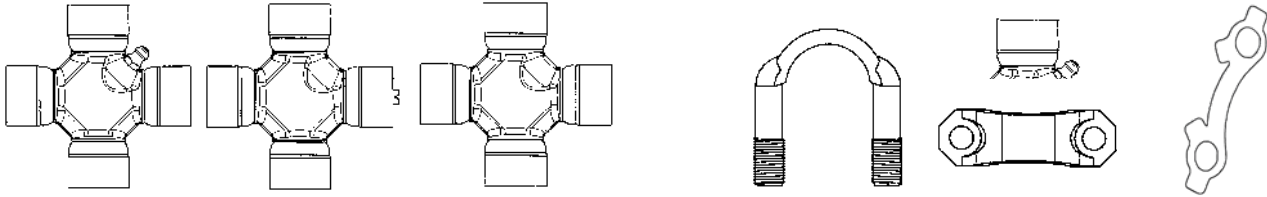

Standard U-Joint	Brute Force Greaseable	Brute Force Non Greaseable	Aluminum Drive Shaft	U Bolt Kit	Clamp Kit	Lock Plate with screws
UJ375	N/A	N/A	N/A	UJ534-10	N/A	
UJ379	UJ280	UJ269	N/A	N/A	N/A	
UJ380	UJ280	UJ269	N/A	N/A	N/A	
UJ387	UJ285	UJ287	N/A	N/A	N/A	
UJ427	N/A	N/A	N/A	UJ330-10	N/A	
UJ428	N/A	N/A	N/A	UJ358-10	N/A	
UJ429	UJ250	N/A	N/A	N/A	N/A	
UJ430	UJ255	UJ230	N/A	UJ534-10	N/A	
UJ434	UJ265	UJ264	N/A	UJ534-10	N/A	
UJ436*	UJ466	UJ436	N/A	N/A	N/A	
UJ437G	UJ240	UJ437	N/A	N/A	UJ437-10	
UJ445	UJ225	N/A	N/A	N/A	UJ360-10	
UJ455	N/A	N/A	N/A	N/A	UJ360-10	
UJ457	N/A	N/A	UJ457C	N/A	UJ318-10	
UJ458	N/A	UJ458BF	N/A	N/A	N/A	
UJ460	N/A	N/A	N/A	N/A	UJN907028X	
UJ475	N/A	N/A	N/A	N/A	UJ475-10	UJ12858
UJ476	N/A	N/A	N/A	N/A	UJ476-10	UJ12859
UJ477	N/A	N/A	N/A	N/A	UJ476-10	UJ12859
UJ478	N/A	N/A	N/A	N/A	UJ476-10	UJ12859
UJ497	N/A	N/A	N/A	UJ329-10	N/A	
UJ498	N/A	N/A	N/A	UJ534-10	N/A	
UJ534G	UJ235	UJ234	N/A	N/A	UJ530-10	
UJ579	N/A	N/A	N/A	N/A	UJN2507018X	

* Standard part is Brute Force

N/A Not Available

Passenger car, light and medium duty truck U-Joints

U-bolt dimensions

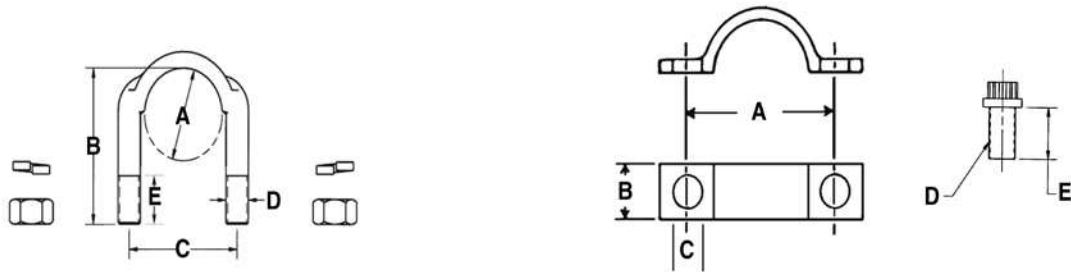

U-bolt kit dimensional size listing

A Bearing OD	B Length	C CL-CL	D Thread Size	E Thread Length	Torque (Ft.-lbs.)	Part Number	Series
1.063"	1.72"	1.406"	5/16-24	0.50"	14-17	UJ329-10	1310/1330
1.188"	1.97"	1.656"	3/8-24	0.62"	20-24	UJ330-10	1350/1410
1.375"	2.25"	1.906"	7/16-20	0.72"	32-37	UJ358-10	1480/1550
1.125"	1.80"	1.578"	5/16-24	0.72"	14-17	UJ534-10	FORD 1310/1330

Bearing clamp kit dimensional size listing

Bearing OD	A CL-CL	B Width	C Hole	D Thread Size	E Under Head	Torque (Ft.-lbs.)	Part Number	Series
1.125"	1.53"	0.62"	0.28"	1/4-28	0.59"	13-18	UJ316-10	7290
1.188"	1.81"	0.75"	0.34"	5/16-24	0.75"	30-35	UJ331-10	1350/1410 (SPR)
1.188"	1.66"	0.75"	0.34"	5/16-24	1.31"	30-35	UJ492-10	1350/1410 (GM)
1.375"	2.12"	0.81"	0.41"	3/8-24	0.75"	55-60	UJ351-10	1480/1550
1.063"	1.59"	0.69"	0.28"	1/4-28	0.59"	13-18	UJ437-10	1310/1330 (SPR)
1.078"	1.50"	0.56"	0.28"	1/4-28	0.62"	13-18	UJ318-10	7260
1.063"	1.59"	0.62"	0.34"	5/16-24	1.50"	30-35	UJ360-10	1310/1330 (GM)
1.125"	1.81"	0.62"	0.34"	5/16-24	1.50"	30-35	UJ530-10	3R
1.375"	1.93"			5/16-24	1.29"		UJ352-10	1480/1550
1.625"	2.31"	0.88"	0.41"	3/8-24	0.75"	45-60	UJN907028X	SPL90/100
1.875"	2.50"	0.94"	0.41"	3/8-24	0.75"	45-60	UJ475-10	1610
1.937"	2.81"	1.00"	0.53"	1/2-20	1.00"	115-135	UJ476-10	1710/1760/1810
2.165"	3.22"	1.10"	0.49"	M12x1.25	0.98"		UJN1707018X	SPL170
2.361"	3.44"	1.13"	0.48"	M12x1.25	0.98"	115-135	UJN2507018X	SPL250

U-joints with 4 grooved round bearings

First, measure the outside diameters of two adjacent bearings to see if they are the same or different. Locate the diameter(s) in the first column using the smaller diameter first if the bearings are of two sizes. Second, remove the seals from two bearings opposite each other and re-install the bearings on the cross. Measure the distance from the inside edge of the lock ring groove on one bearing across the joint to the same point on the opposite bearing and write it down. See drawing below. Next measure the thickness of two lock rings together. Add this measurement to the first measurement and the total should be slightly less than the "installed" dimension shown in the second column. If necessary, note the type and location of any lube fittings.

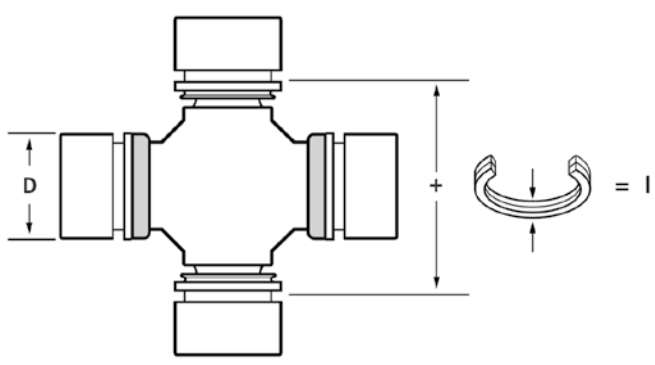

Dimension D Bearing Diameter	Dimension I Includes Locks	Lube Fitting	Part Number	OE Series
0.788" (20.0mm)	1.496" (38.0mm)	Yes ⁸	UJ392	Nissan
0.867"	1.400"	Yes ⁸	UJ10430	Nissan, Subaru, Toyota
0.886" (22.5mm)	1.496" (38.0mm)	Yes ⁸	UJ385	Mazda
0.938" (15/16")	1.485" (1 31/64")	Yes ⁴	UJ1500¹¹	Neapco 0600
		Yes ⁸	UJ1501	
		Yes ⁸	UJ1502	
0.938" (15/16") 2	1.500" (1 1/2")	Yes ⁴	UJ338	Spicer 1000
		Yes ⁸	UJ838	
		No	UJ10103	
0.938" (15/16") 2	1.500" (1 1/2")	Yes ⁴	UJ840	Combination UJ338 X UJ861
0.969" (31/32") 2	1.444" (1 29/64")			
0.947"	1.900"	Yes ⁸	UJ10431	BMW, Mazda
0.969" (31/32")	1.444" (1 29/64")	Yes ⁴	UJ861	Rockwell L6N
		Yes ⁸	UJ839	
		Yes ⁴	UJ983	
0.985" (25.0mm)	1.717" (43.6mm)	Yes ⁸	UJ397	Mazda
	1.732" (44.0mm)	Yes ⁸	UJ391	Nissan & Subaru
1.000" (1")	1.719" (1 23/32")	Yes ⁸	UJ5146	Mechanics 1.75
	2.344" (2 11/32")	No	UJ515¹⁶	Mechanics 2
		Yes ¹	UJ507	

(Continued)

1 Regular lube fitting in cross

4 Angled lube fitting in center of cross

8 Regular lube fitting in bearing

9 Flush-type lube fitting in bearing

11 Plain bearing - No needles

16 Special pocketed cross forging

Passenger car, light and medium duty truck U-Joints

U-joints with 4 grooved round bearings

Dimension D Bearing Diameter	Dimension I Includes Locks	Lube Fitting	Part Number	OE Series
1.024" (26.0mm)	1.843" (46.8mm)	Yes ⁸	UJ394	Toyota
	2.205" (56.0mm)	Yes ¹	UJ390	
1.044" (26.5mm)	1.988" (50.5mm)	Yes ⁸	UJ386	Kia & Mazda
1.063" - 1.064" (1 1/16" / 27.0mm)	1.640" (1 41/64")	No	UJ436	Spicer 1210-WJ
		Yes ⁹	UJ466	
	1.818"	Yes ⁴	UJ995	Rockwell L12N
	1.930" (49.0mm)	No	UJ446	Nissan
	2.188" (2 3/16")	No	UJ365	Spicer 1310-WJ
		Yes ⁹	UJ378	
	2.343" (2 11/32")	Yes ¹	UJ368	Spicer 1310
	2.375" (2 3/8")	Yes ¹	UJ429	Cleveland S55
2.375" x 2.781"	Yes ¹	UJ431	Combination UJ429 X UJ433	
2.781" (2 25/32")	Yes ¹	UJ433	Cleveland P55	
1.078" (1 5/64")	2.125" (2 1/8")	Yes ¹	UJ315G	Detroit 7260
		Yes ⁸	UJ317	
		Yes ⁴	UJ832M	
1.078" (1 5/64") 2	2.125" (2 1/8")	Yes ¹	UJ347	Combination UJ315G X UJ316
1.125" (1 1/8") 2	2.625" (2 5/8")			
1.102"	2.024"	Yes ⁸	UJ10436	Kia
1.103" (28.0mm)	2.205" (56.0mm)	Yes ¹	UJ393	Nissan & Subaru
	2.323" (59.0mm)	Yes ⁸	UJ384	Mazda
1.125" (1 1/8")	1.95"	Yes ⁴	UJ880H	Howse 14
	2.125" (2 1/8")	Yes ⁸	UJ513	Mechanics 2.5
	2.557"	No	UJ492¹⁶	Mechanics 3 & Saginaw 44 & American Axle 1344
		Yes ¹	UJ534G	
	2.625" (2 5/8")	Yes ¹	UJ316	Detroit 7290
	3.250" (3 1/4")	Yes ¹	UJ545	Mechanics 4
1.142" (29.0mm)	2.047" (52.0mm)	Yes ⁸	UJ387	Toyota
	2.087" (53.0mm)	Yes ⁸	UJ383	Isuzu
	2.835" (53.0mm)	Yes ⁸	UJ411	
1.181" (30.0mm)	2.290" (58.15mm)	Yes ⁴	UJ450	Mitsubishi

(Continued)

1 Regular lube fitting in cross

4 Angled lube fitting in center of cross

8 Regular lube fitting in bearing

9 Flush-type lube fitting in bearing

11 Plain bearing - No needles

16 Special pocketed cross forging

U-joints with 4 grooved round bearings

Dimension D Bearing Diameter	Dimension I Includes Locks	Lube Fitting	Part Number	OE Series
1.188" (1 3/16")	2.188" (2 3/16")	No Yes ⁹	UJ371 UJ377	Spicer 1310-WJ
	2.563" (2 9/16")	Yes ¹	UJ423	Cleveland R55
	3.125" (3 1/8")	Yes ¹	UJ427	Cleveland 055
1.188"	2.405"	No	UJ20057	SPL30WJ/1350WJ
1.231" (1 15/64")	2.000" (2")	Yes ⁴	UJ305	Detroit 5160
	3.000" (3")	Yes ¹	UJ304	Detroit 5380
1.250" (1 1/4")	2.14"	Yes ⁴	UJ964H	Howse 35
1.260" (32.0mm)	2.520" (64.0mm)	Yes ¹	UJ389	Toyota
1.260"	2.362"	Yes ¹	UJ20508	Kia
1.310" (1 5/16")	2.795" (2 51/64")	Yes ⁴	UJ888	Rockwell 44R
1.313" (1 5/16")	4.313" (4 5/16")	Yes ¹	UJ567	Mechanics 6
1.339" (34.0mm)	2.205" (56.0mm)	Yes ⁴	UJ816	Walterscheid II
	2.915" (74.0mm)	Yes ¹	UJ464	American Axle 1485-WJ
1.375" (1 3/8")	3.000" (3")	Yes ¹ No	UJ374 UJ374BF	Spicer 1480-WJ (SPL55)
	3.702" (94.0mm)	Yes ¹	UJ479	American Axle 1555-WJ
	3.780" (96.0mm)	Yes ¹	UJ424	Spicer 1550-WJ (SPL70)

1 Regular lube fitting in cross
4 Angled lube fitting in center of cross

8 Regular lube fitting in bearing
9 Flush-type lube fitting in bearing

11 Plain bearing - No needles
16 Special pocketed cross forging

Passenger car, light and medium duty truck U-Joints

U-joints with 4 plain round bearings

First, measure the outside diameters of two adjacent bearings to see if they are the same or different. Locate the diameter(s) in the first column using the smaller diameter first if the bearings are of two sizes. Second, remove the seals from two bearings opposite each other and re-install the bearings on the cross. Measure the overall dimension and locate it in the second column. Note, the measured dimension should be slightly less than that shown. If necessary, note the type and location of any lube fittings.

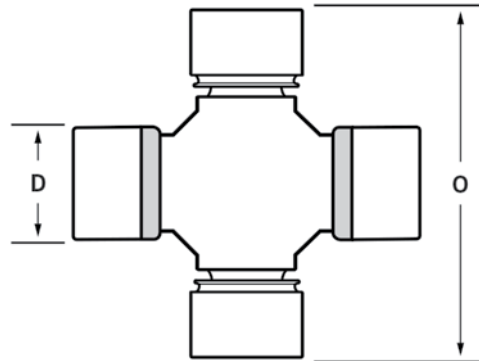

Dimension D Bearing Diameter	Dimension O Back to Back	Lube Fitting	Part Number	OE Series
0.750" (3/4")	1.906" (1 29/32")	No	UJ405	0400SG
0.788" (20.0mm)	2.166" (55.0mm)	Yes ⁸	UJ410	Kubota
	2.244" (57.0mm)	Yes ⁸	UJ395	Toyota
0.868" (22.0mm)	2.126" (54.0mm)	Yes ⁴	UJ811	Bondioli 1
	2.157" (54.8mm)	Yes ⁴	UJ812	Walterscheid 2
0.875" (7/8")	2.469" (2 15/32")	Yes ⁸	UJ870	Rockwell L10N
0.938" (15/16")	2.411" (2 13/32")	No	UJ340	Spicer 1100
		Yes ³	UJ341	
		Yes ⁸	UJ341BL	
		Yes ⁴	UJ341AG	
0.945" (24.0mm)	2.490" (63.25mm)	No	UJ413	Alfa Romeo
0.985" (25.0mm)	2.524" (64.1mm)	No	UJ398	Mitsubishi
	3.012" (76.5mm)	Yes ¹	UJ399	
1.024" (26.0mm)	2.756" (70.0mm)	Yes ⁸	UJ408	Suzuki

(Continued)

- 1 Regular lube fitting in cross
- 2 Flush-type lube fitting in cross
- 3 Long lube fitting in cross
- 4 Angled lube fitting in center of cross

- 5 Two regular lube fittings in cross
- 8 Regular lube fitting in bearing
- 9 Flush-type lube fitting in bearing

- 20 Our kit is designed to fit applications with one half round yoke and one full round yoke
- * Inside/Outside lockup options

U-joints with 4 plain round bearings

Dimension D Bearing Diameter	Dimension O Back to Back	Lube Fitting	Part Number	OE Series	
1.063" (1 1/16") (27.0mm)	2.438" (2 7/16")	Yes ⁹	UJ240	Brute Force for UJ437 or UJ437G	
		No	UJ237		
		No	UJ437	Spicer 1210	
		Yes ⁸	UJ437G		
	2.650" (2 21/32")	Yes ⁴	UJ409	Chev. / GMC / Pontiac & Saturn	
		Yes ⁸	UJ10439		
	2.756" (70.0mm)	Yes ⁴	UJ813	Bondioli 3 & Walterscheid I	
	2.935" (2 15/16")	Yes ¹	UJ344	Spicer 1300	
		Yes ⁴	UJ344AG	Bondioli 4 & Walterscheid 2300	
	3.218" (3 7/32")	No	No	UJ269	Brute Force for UJ369 or UJ379
			Yes ⁹	UJ280	
		Yes ¹	UJ369	Spicer 1310	
		Yes ¹	UJ369C	For Aluminum Drive Shaft	
		Yes ²	UJ379	Spicer 1310	
		Yes ⁹	UJ380		
	3.218" x 3.622"	Yes ⁹	UJ275	Brute Force for UJ353	
		Yes ¹	UJ353	Spicer 1310 & 1330	
	3.622" (3 5/8")	No	UJ254	Brute Force for UJ354	
		Yes ⁹	UJ270		
		Yes ¹	UJ354	Spicer 1330	
No		UJ345	Visteon 1330 (Brg. OD 1.066")		
1.063" (1 1/16") 2	3.218" (3 7/32")	Yes ¹	UJ430*	Ford 1310	
1.125" (1 1/8") 2	3.622" (3 5/8")	Yes ¹	UJ434*	Ford 1330	
1.063" (1 1/16") 2 1.188" (1 3/16") 2	3.218"(3 7/32") x 3.622"(3 5/8")	Yes ¹	UJ348	Combination UJ369 X UJ331	
		Yes ¹	UJ448	Combination UJ354 X UJ331	
1.066"	3.787"	No	UJ30488	Ford-Staked Joint	
1.123" (28.5mm)	3.071" (78.0mm)	Yes ⁴	UJ396	Toyota	
1.125" (1 1/8")	2.625" (2 5/8")	Yes ⁴	UJ880	Rockwell L14N	
		Yes ⁸	UJ882		
1.125" (1 1/8") 2 1.188" (1 3/16") 2	3.622" (3 5/8")	Yes ¹	UJ459	Combination UJ434 X UJ331	
1.181" (30.0mm)	3.268" (83.0mm)	No	UJ451	ZF	

(Continued)

- 1 Regular lube fitting in cross
- 2 Flush-type lube fitting in cross
- 3 Long lube fitting in cross
- 4 Angled lube fitting in center of cross

- 5 Two regular lube fittings in cross
- 8 Regular lube fitting in bearing
- 9 Flush-type lube fitting in bearing

- 20 Our kit is designed to fit applications with one half round yoke and one full round yoke
- * Inside/Outside lockup options

Passenger car, light and medium duty truck U-Joints

U-joints with 4 plain round bearings

Dimension D Bearing Diameter	Dimension O Back to Back	Lube Fitting	Part Number	OE Series
1.188" (1 3/16")	3.150" (80.0mm)	Yes ⁴	UJ815	Bondioli 5
	3.228" (82.0mm)	No	UJ456	Carraro
	3.622" (3 5/8")	No	UJ231	Brute Force for UJ331
		Yes ⁹	UJ232	
		Yes ¹	UJ331	Spicer 1350 (SPL30)
		Yes ⁸	UJ331BL	
		Yes ¹	UJ331C	
		Yes ⁹	UJ232A	Brute Force for UJ331A
		Yes ¹	UJ331A	American Axle 1355
	Yes ⁴	UJ331AG	Bondioli 6 & Walterscheid 220	
	3.622"(3 5/8") x 4.187"(4 3/16")	No	UJ21435	Combination UJ331XUJ330
	4.178"	Yes ⁹	UJ295A	Brute Force for UJ330A
		Yes ¹	UJ330A	American Axle 1415
	4.187" (4 3/16")	Yes ⁹	UJ295	Brute Force for UJ330
		Yes ¹	UJ330	Spicer 1410 (SPL36)
Yes ¹		UJ330C	For Aluminum Drive Shaft	
1.188" (1 3/16") 2 1.375" (1 3/8") 2	4.187" (4 3/16")	No	UJ31448	Spicer 1410 x Spicer 1480
1.250" (1 1/4")	3.210"	Yes ⁴ Yes ⁸	UJ964 UJ934	Rockwell 35N
1.260" (32.0mm)	2.992" (76.0mm)	Yes ⁴	UJ814	Walterscheid 2400
1.300" (33.0mm)	3.662" (93.0mm)	Yes ⁴	UJ382	Isuzu
1.375" (1 3/8")	3.701" (94.0mm)	Yes ⁴	UJ818	Bondioli 7
	4.178"	Yes ¹	UJ351A	American Axle 1485
		No	UJ351ABF	Brute Force for UJ351A
		Yes ¹	UJ351	Spicer 1480 (SPL55)
	4.187" (4 3/16")	No	UJ351BF	Brute Force for UJ351
		Yes ⁴	UJ351AG	Bondioli 8 & Walterscheid 240
		Yes ¹	UJ351C	For Aluminum Drive Shaft
	4.956"	Yes ¹	UJ358A	American Axle 1555
		No	UJ358ABF	Brute Force for UJ358A
	4.965"	Yes ¹	UJ358	Spicer 1550 (SPL70)
		No	UJ358BF	Brute Force for UJ358
Yes ¹		UJ36800	Cleveland U56-55-2	

(Continued)

- 1 Regular lube fitting in cross
- 2 Flush-type lube fitting in cross
- 3 Long lube fitting in cross
- 4 Angled lube fitting in center of cross

- 5 Two regular lube fittings in cross
- 8 Regular lube fitting in bearing
- 9 Flush-type lube fitting in bearing

- 20 Our kit is designed to fit applications with one half round yoke and one full round yoke
- * Inside/Outside lockup options

U-joints with 4 plain round bearings

Dimension D Bearing Diameter	Dimension O Back to Back	Lube Fitting	Part Number	OE Series
1.378" (35.0mm)	4.092" (103.9mm)	Yes ⁴	UJ461	Isuzu
1.417" (36.0mm)	3.496" (88.8mm)	Yes ⁴	UJ817	Walterscheid 2500
1.531" (1 17/32")	4.312" (4 5/16")	Yes ¹	UJ889	Rockwell 55N
1.562" (1 9/16")	4.562" (4 9/16")	Yes ¹	UJ370	Hardy Spicer 1510
1.614" (41.0mm)	4.250" (108mm)	Yes ¹	UJ30921	Bondioli & Pavesi
	4.646" (118mm)	Yes ¹	UJ31021	
	4.955" (126.0mm)	Yes ¹	UJ460	
1.625" (1 5/8")	5.064" (5 1/16")	Yes ⁴	UJ898	Rockwell 750N
	5.590" (5 19/32")	Yes ¹	UJ359	Spicer 1650
1.654" (42.0mm)	4.094" (104.0mm)	Yes ⁴	UJ821	Walterscheid 2600
1.937" (1 15/16")	5.934" (5 15/16")	Yes ⁵	UJ899	Rockwell 850N
2.165" (55.0mm)	6.456" (164.0mm)	Yes ⁵	UJ578²⁰	Spicer SPL170
2.362" (60.0mm)	6.417" (163.0mm)	Yes ⁴	UJ579²⁰	Spicer SPL250

- 1 Regular lube fitting in cross
- 2 Flush-type lube fitting in cross
- 3 Long lube fitting in cross
- 4 Angled lube fitting in center of cross

- 5 Two regular lube fittings in cross
- 8 Regular lube fitting in bearing
- 9 Flush-type lube fitting in bearing

- 20 Our kit is designed to fit applications with one half round yoke and one full round yoke
- * Inside/Outside lockup options

Passenger car, light and medium duty truck U-Joints

U-joints with 2 grooved & 2 plain round bearings

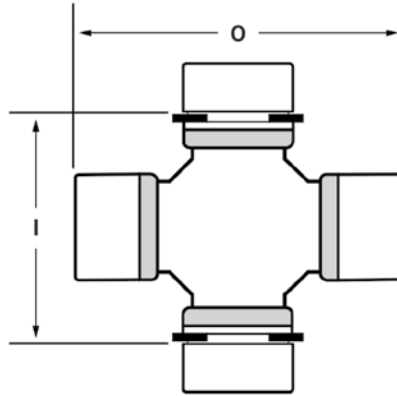

Bearing Diameter	Bearing Type	Dimension I Includes Locks	Dimension O Without Locks	Lube Fitting	Part Number	OE Series
1.000" (1")	Grooved	1.719" (1 23/32")	2.438" (2 7/16")	Yes ⁴	UJ361	Combination UJ514G X UJ437G
1.063" (1 1/16")	Plain	2.344" (2 11/32")	3.218" (3 7/32")	Yes ¹	UJ505	Combination UJ507 X UJ369
1.000" (1")	Grooved	2.344" (2 11/32")	3.218" (3 7/32")	Yes ¹	UJ498	Combination UJ507 X UJ430
1.125" (1 1/8")	Plain					
1.063" (1 1/16")	Grooved	2.188" (2 3/16")	3.218" (3 7/32")	Yes ¹	UJ455	Combination UJ365 X UJ369
1.063" (1 1/16")	Plain	2.344" (2 11/32")	3.218" (3 7/32")	Yes ¹	UJ445	Combination UJ368 X UJ369
1.063" (1 1/16")	Grooved	2.375" (2 3/8")	3.218" (3 7/32")	Yes ¹	UJ430	Ford & Mercury
1.125" (1 1/8")	Plain	2.781" (2 25/32")	3.622" (3 5/8")	Yes ¹	UJ434	
1.078" (1 5/64")	Grooved	2.125" (2 1/8")	3.218" (3 7/32")	Yes ¹	UJ319	Combination UJ315G X UJ369
1.063" (1 1/16")	Plain		3.622" (3 5/8")	Yes ²	UJ457	Combination UJ315G X UJ354
1.078" (1 5/64")	Grooved	2.125" (2 1/8")	3.218" (3 7/32")	Yes ¹	UJ320	Combination UJ315G X UJ430
1.125" (1 1/8")	Plain					
1.125" (1 1/8") 1.063" (1 1/16")	Grooved Plain	2.125" (2 1/8")	3.218" (3 7/32")	Yes ⁸	UJ497	Combination UJ513 X UJ369
			3.218" (3 7/32")	Yes ¹	UJ372	Combination UJ534G X UJ369
			3.622" (3 5/8")	Yes ¹	UJ355	Combination UJ534G X UJ354
			3.218" (3 7/32")	Yes ¹	UJ449	Combination UJ316 X UJ369
1.125" (1 1/8") 1.125" (1 1/8")	Grooved Plain	2.625" (2 5/8")	3.622" (3 5/8")	Yes ²	UJ458	Combination UJ316 X UJ354
			3.622" (3 5/8")	No	UJ458BF	
1.125" (1 1/8") 1.125" (1 1/8")	Grooved Plain	2.560" (2 9/16")	3.622" (3 5/8")	Yes ¹	UJ375	Combination UJ534G X UJ434
1.125" (1 1/8") 1.188" (1 3/16")	Grooved Plain	2.560" (2 9/16")	3.622" (3 5/8")	Yes ¹	UJ447	Combination UJ534G X UJ331
1.231" (1 15/64") 1.188" (1 3/16")	Grooved Plain	3.000" (3")	4.187" (4 3/16")	Yes ¹	UJ362	Combination UJ304 X UJ330

- 1 Regular lube fitting in cross
2 Flush-type lube fitting in cross

- 4 Angled lube fitting in center of cross
8 Regular lube fitting in bearing

SKF Driveshaft Flexible Coupler

Featuring proprietary Tenpu® fiber technology

SKF offers a full line of 39 driveshaft flexible couplers engineered for smooth operation and optimal road performance.

Dependable, high-quality SKF driveshaft flexible couplers are manufactured to OE specifications for a variety of luxury vehicles, ensuring seamless installation and reduced downtime.

Torque is transferred through Tenpu® cord inlays vulcanized into the couplers that absorb start-up impact and reduce shock, control over-loading and reduce noise and vibration. The result is a smooth transfer of rotational motion—ideal for luxury vehicles—enhancing the driving experience.

Features and benefits

Designed and validated to OEM quality standards

- Precision manufactured in Germany
- Durable vulcanized rubber construction
- Backed by an industry-leading, 12-month warranty
- Absorbs angular, radial, and axial misalignment
- Isolates noises due to the interruption of the structure-borne vibration path



SKF Driveshaft Flexible Coupler

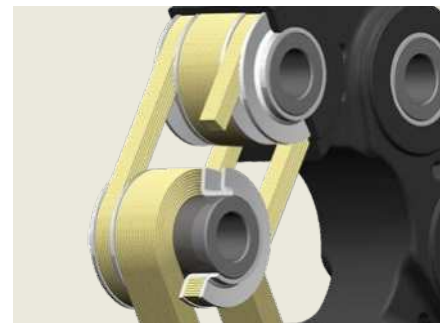
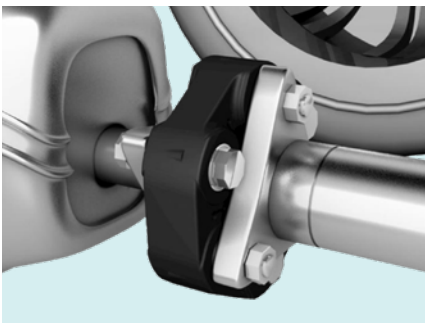

Heavy Duty Trucks Section

Driveline series

Popular U-Joint Series	Standard Part No.	Brute Force Greaseable	Brute Force Non Greaseable	Yoke Lockup	Bearing Diameter	Brg Cap Style	Brg Cap Construction	Lube Fitting
0400SG Series	UJ405			1.906(0)	0.750	4 Plain Round Bearings	OSR	No
Cleveland 055	UJ427			3.125(0)	1.188	4 Grooved Round Bearings	ISR	Yes
Combination UJ534G X UJ354	UJ355	UJ290		2.560 (Inside Lock Up 1) / 3.622 (Inside Lock Up 2)	1.125 (Brg. Cap OD 1) / 1.063 (Brg. Cap OD 2)	2 Grooved & 2 Plain Round Brgs	2 ISR & 2 OSR	Yes
Combination UJ534G X UJ369	UJ372			2.560 (Inside Lock Up 1) / 3.218 (Inside Lock Up 2)	1.125 (Brg. Cap OD 1) / 1.063 (Brg. Cap OD 2)	2 Grooved & 2 Plain Round Brgs	2 ISR & 2 OSR	Yes
Detroit 7260	UJ315G	UJ246		2.125(I)	1.078	4 Grooved Round Bearings	ISR	Yes
Detroit 7290	UJ316	UJ248		2.625(I)	1.125	4 Grooved Round Bearings	ISR	Yes
Ford 1330	UJ434	UJ265	UJ264	2.781 (Inside Lock Up 1) / 3.622 (Inside Lock Up 2)	1.125 (Brg. Cap OD 1) / 1.063 (Brg. Cap OD 2)	2 Grooved & 2 Plain Round Brgs	2 ISR & 2 OSR	Yes
Heavy Trucks (1610 Series)	UJ333			5.312(0)	1.875	4 Welded Plate Type Round Brg		Yes
Heavy Trucks (1760 Series)	UJ376			7.000(0)	1.937	4 Welded Plate Type Round Brg		Yes
Mechanics 3	UJ534G	UJ235	UJ234	2.557(0)	1.125	4 Grooved Round Bearings	ISR	Yes
Mechanics 9C	UJ911			2.810(CtC) Across Bearing / 6.620(CtC) Across Joint		4 Wing Bearings	4 HWD	Yes
Mechanics9C & Spicer 1810	UJ480			7.550(I)	1.937	2 RD W/Welded Plate & 2 HWD	2 Plate & 2 HWD	Yes
Mechanics9C & Spicer 1880	UJ488			8.090(I)	2.186	2 RD W/Welded Plate & 2 HWD	2 Plate & 2 HWD	Yes
Rockwell/Meritor L6N	UJ861			1.444(I)	.969	4 Grooved Round Bearings	ISR	Yes
Spicer 1000	UJ338			1.500(I)	0.938	4 Grooved Round Bearings	ISR	Yes

(Continued)

Heavy duty truck U-Joints

Driveline series

Popular U-Joint Series	Standard Part No.	Brute Force Greaseable	Brute Force Non Greaseable	Yoke Lockup	Bearing Diameter	Brg Cap Style	Brg Cap Construction	Lube Fitting
Spicer 1210	UJ437G	UJ240	UJ237	2.438(0)	1.063	4 Plain Round Bearings	OSR	No
Spicer 1310	UJ369	UJ280	UJ269	3.218(0)	1.063	4 Plain Round Bearings	OSR	Yes
Spicer 1310 Wheel Joint	UJ371	UJ377		2.188(l)	1.188	4 Grooved Round Bearings	ISR	No
Spicer 1310x1330	UJ353	UJ275		3.218(0) 1 & 3.622 (0) 2	1.063	4 Plain Round Bearings	OSR	Yes
Spicer 1350	UJ331	UJ232	UJ231	3.622(0)	1.188	4 Plain Round Bearings	OSR	Yes
Spicer 1410	UJ330	UJ295		4.187(0)	1.188	4 Plain Round Bearings	OSR	Yes
Spicer 1480	UJ351		UJ351BF	4.187(0)	1.375	4 Plain Round Bearings	OSR	Yes
Spicer 1480 Wheel Joint	UJ374		UJ374BF	3.000(0)	1.375	4 Grooved Round Bearings	ISR	Yes
Spicer 1550	UJ358		UJ358BF	4.965(0)	1.375	4 Plain Round Bearings	OSR	
Spicer 1610	UJ475			5.312(0)	1.875	2 Welded Plate & 2 Round Bearing		Yes
Spicer 1710	UJ334			6.094(0)	1.937	4 Welded Plate Type Round Bearing		Yes
Spicer 1710	UJ476			6.094 (BP)	1.937	2 Welded Plate & 2 Round Bearing		Yes
Spicer 1760	UJ477			7.000(BP)	1.937	2 Welded Plate & 2 Round Bearing		Yes
Spicer 1810	UJ381			7.547(0)	1.937	4 Welded Plate Type Round Brg		Yes
Spicer 1810	UJ478			7.547(BP)	1.937	2 Welded Plate & 2 Round Bearing		Yes
Spicer 1880	UJ388			8.094(BP)	2.186	4 Welded Plate Type Round Brg		Yes
Spicer SPL170	UJ578			6.456(0)	2.165	4 Plain Round Bearings	OSR	Yes
Spicer SPL250	UJ579			6.417(0)	2.362	4 Plain Round Bearings	OSR	Yes
Spicer SPL90/100	UJ460			4.955(0)	1.625	4 Plain Round Bearings	OSR	Yes
Spicer1330	UJ354	UJ2701	UJ254	3.622(0)	1.063	4 Plain Round Bearings	OSR	Yes

Heavy duty series by dimension

Yoke Lockup	Bearing Diameter	Series	Part number
1.444(I)	0.969	Rockwell/Meritor L6N	UJ861
1.500(I)	0.938	Spicer 1000	UJ338
1.906(0)	0.750	0400 Sg	UJ405
3.125(I)	1.188	Cleveland 055	UJ427
3.218(0)	1.063	Spicer 1310	UJ369
3.622(0)	1.188	Spicer 1350	UJ331
4.187(0)	1.188	Spicer 1410	UJ330
4.187(0)	1.375	Spicer 1480	UJ351
4.955(0)	1.625	Spicer SPL90/100	UJ460
4.965(0)	1.375	Spicer 1550	UJ358
5.312(0)	1.875	Spicer 1610-4 Welded Plate Type Round Bearing	UJ333
5.312(0)	1.875	Spicer 1610-2 Welded Plate & 2 Round Bearing	UJ475
6.094(0)	1.937	Spicer 1710-4 Welded Plate Type Round Bearing	UJ334
6.187(0)	1.937	Spicer 1710-2 Welded Plate & 2 Round Bearing	UJ476
6.417(0)	2.362	Spicer SPL250-4 Plain Round Bearings	UJ579
6.456(0)	2.165	Spicer SPL170-4 Plain Round Bearings	UJ578
6.62 Ctr.-Ctr.	2.81 Ctr.-Ctr.	Mechanics 9C-4 Wing Bearings	UJ911
7.000(0)	1.937	Spicer 1760-4 Welded Plate Type Round Bearing	UJ376
7.093(0)	1.937	Spicer 1760-2 Welded Plate & 2 Round Bearing	UJ477
7.547(0)	1.937	Spicer 1810-4 Welded Plate Type Round Bearing	UJ381
7.550(0)	1.937	Mechanics9C & Spicer 1810	UJ480
7.640(0)	1.937	Spicer 1810-2 Welded Plate & 2 Round Bearing	UJ478

Popular heavy duty interchanges

Driveline Series	Part number	Meritor	Neapco	Precision	Spicer
1610 Full Round	UJ333	CP279X	4-0279	333	5-279X
1610 Half Round	UJ875	CP674X	4-0674	875	5-674X
1610 Half Round	UJ475*	CP674X	4-0674	475	5-674X
1710 Full Round	UJ334	CP280X	5-0280	334	5-280X
1710 Half Round	UJ876	CP675X	6-0675	876	5-675X
1710 Half Round	UJ476*	CP675X	6-0675	476	5-675X
1760 Full Round	UJ376	CP407X	6-0407	376	5-407X
1760 Half Round	UJ877	CP677X	6-0677	877	5-677X
1760 Half Round	UJ477*	CP677X	6-0677	477	5-677X
1810 Full Round	UJ381	CP281X	6-0281	381	5-281X
1810 Half Round	UJ878	CP676X	6-0676	878	5-676X
1810 Half Round	UJ478*	CP676X	6-0676	478	5-676X
1810/9C	UJ480	CP18N96	6-1250	480	5-324X
Mechanics 5C	UJ968	CP5177	4-5177	968	5-5177X
Mechanics 6C	UJ560	CP62N47	4-6143	560	5-6000X
Mechanics 6C	UJ905	CP62N-HWD	4-6128	905	5-6106X
Mechanics 7C	UJ570	CP72N38	5-7205	570	5-7000X
Mechanics 7C	UJ574	CP72N45	5-7207	574	5-7202X
Mechanics 7C	UJ927	CP72N-HWD	5-7126	927	5-7105X
Mechanics 8C	UJ928	CP82N-HWD	6-8133	928	5-8105X
SPL170	UJ578	US170X	6-1170	578	SPL170-3X
SPL250	UJ579	US250X	6-1250	579	SPL250-3X
Spicer SPL90/100	UJ460	—	4-1090	460	SPL100-1X

* Without clamp kit

U-joints with 4 welded plate type round bearings

First, measure the bearing diameter and locate in the first column. Second, measure the distance between two opposite plates and locate in column two. If necessary, note the type and quantity of any lube fittings.

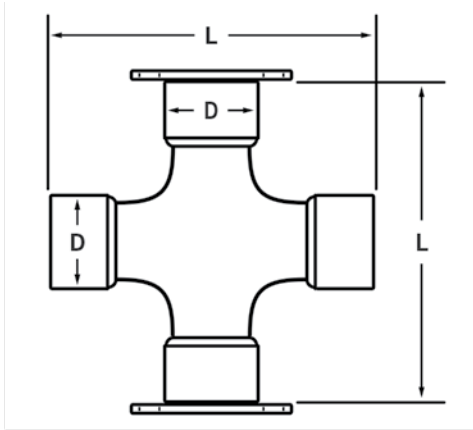
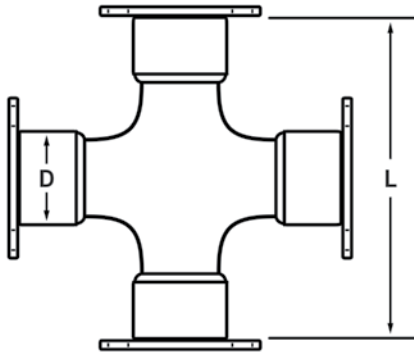

Dimension D Bearing Diameter	Dimension L Between Plates	Lube Fitting	Part Number	Lock Plate Kit w/Cap Screws	OE Series
1.562" (1 9/16")	4.562" (4 9/16")	Yes ¹	UJ332		Spicer 1500
1.875" (1 7/8")	5.312" (5 5/16")	Yes ⁵	UJ333	UJ12858	Spicer 1610
1.937" (1 15/16")	6.094" (6 3/32")	Yes ⁵	UJ334	UJ12859	Spicer 1710
	7.000" (7")	Yes ⁵	UJ376	UJ12859	Spicer 1760
	7.547" (7 35/64")	Yes ⁵	UJ381	UJ12859	Spicer 1810
2.186" (2 3/16")	8.094" (8 3/32")	Yes ¹	UJ388		Spicer 1880
2.312" (2 5/16")	6.594" (6 19/32")	Yes ⁵	UJ335		Spicer 1800

1 Regular lube fitting in cross

5 Two regular lube fittings in cross

U-joints with 2 welded plate type & 2 plain round bearings

Dimension D Bearing Diameter	Dimension L Between Plates	Dimension L Back to Back	Lube Fitting	Part Number	Lock Plate Kit w/Cap Screws	OE Series
1.875" (1 7/8")	5.312" (5 5/16")	5.312" (5 5/16")	Yes ⁵	UJ475 or UJ875²¹	UJ12858	Spicer 1610
	6.094" (6 3/32")	6.187" (6 3/16")	Yes ⁵	UJ476 or UJ876²¹	UJ12859	Spicer 1710
1.937" (1 15/16")	7.000" (7")	7.093" (7 3/32")	Yes ⁵	UJ477 or UJ877²¹	UJ12859	Spicer 1760
	7.547" (7 35/64")	7.640" (7 41/64")	Yes ⁵	UJ478 or UJ878²¹	UJ12859	Spicer 1810

5 Two regular lube fittings in cross

21 Includes Clamp Kit

Heavy duty truck U-Joints

U-joints with 4 wing bearings

Measure across the assembled kit from the machined radius on the back of one bearing to the same position on the opposite bearing. Locate this dimension in the first column. Measure the center to center distance of the bolt holes on any one bearing and locate this dimension in the second column. Note that there are some kits that combine the dimensions of Mechanics sizes 6 and 7 on the same u-joint. Find the quantity and type of bearings in the third column.

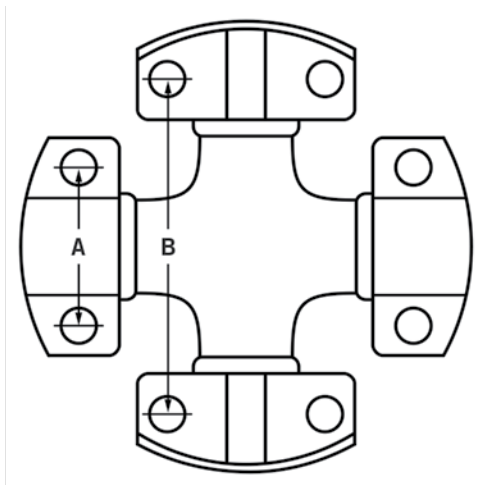

LWT Low Wing Threaded

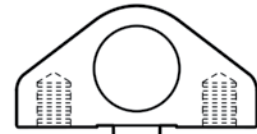

DWT Delta Wing Threaded

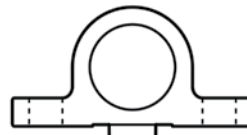

LWD Low Wing Drilled

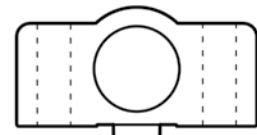

HWD High Wing Drilled

Dimension A Across Bearing	Dimension B Across U-joint	Bearing Quantity and Type	Lube Fitting	Part Number	OE Series
1.31" (1 5/16")	2.34" (2 11/32")	4 LWT	Yes ¹	UJ951	Mechanics 2C
			Yes ⁸	UJ453	
		4 LWD	Yes ¹	UJ994	
			Yes ⁸	UJ454	
		2 LWT & 2 LWD	Yes ¹	UJ952	
			Yes ⁸	UJ452	
1.44" (1 7/16")	2.75" (2 3/4")	4 LWT	No	UJ530	Mechanics 3C
			Yes ¹	UJ536	
		4 LWD	Yes ¹	UJ495	
		2 LWT & 2 LWD	Yes ¹	UJ535	
		2 LWD & 2 HWD	Yes ⁸	UJ539	
1.44" (1 7/16")	3.44" (3 7/16")	4 LWT	Yes ¹	UJ540	Mechanics 4C
		4 LWD	Yes ¹	UJ549	
		4 HWD	Yes ¹	UJ969	
		2 LWT & 2 LWD	Yes ¹	UJ541	
		2 LWT & 2 HWD	Yes ¹	UJ929	

(Continued)

- 1 Regular lube fitting in cross
- 3 Long lube fitting in cross
- 5 Two regular lube fittings in cross
- 6 Two angled lube fittings in cross

- 7 Four long lube fittings in cross
- 8 Regular lube fitting in bearing
- 14 Two HWD bearings double keyed for CV

- 15 Our production uses delta wing brgs. in place of low wing bearings
- 23 Includes 12 pt cap screws

U-joints with 4 wing bearings

Dimension A Across Bearing	Dimension B Across U-joint	Bearing Quantity and Type	Lube Fitting	Part Number	OE Series
1.688	4.529"	4 HWD	No	UJ45262	Mechanics 5C
1.69	3.50" (3 1/2")	4 LWD	Yes ³	UJ999	Mechanics 5C
1.69" (1 11/16")	3.50" (3 1/2")	4 LWT	Yes ¹	UJ550	Mechanics 5C
		4 DWT	Yes ³	UJ550	
		4 HWD	Yes ³	UJ968	
		2 LWT & 2 LWD	Yes ³	UJ552¹⁵	
		2 LWT & 2 HWD	Yes ³	UJ933¹⁵	
		2 LWD & 2 HWD	Yes ³	UJ558¹⁵	
1.69" (1 11/16")	4.50" (4 1/2")	4 LWT	Yes ¹	UJ560¹⁵	Mechanics 6C Rockwell 62N
		4 DWT	Yes ¹	UJ760	
		4 LWD	Yes ¹	UJ566¹⁵	
		4 HWD	Yes ¹	UJ905	
		4 HWD ¹⁴	Yes ¹	UJ481	
		2 LWT & 2 LWD	Yes ¹	UJ561¹⁵	
		2 LWT & 2 HWD	Yes ¹	UJ563¹⁵	
1.69" (1 11/16") X 1.94" (1 15/16")	4.50" (4 1/2") X 4.62" (4 5/8")	2 LWT & 2 LWT	Yes ¹	UJ568¹⁵	Mechanics 6C X Mechanics 7C
		2 LWT & 2 HWD	Yes ¹	UJ569¹⁵	
		2 HWD & 2 LWT	Yes ¹	UJ924¹⁵	
		2 HWD & 2 HWD	Yes ¹	UJ926	
1.93" (49mm)	4.10" (104mm)	4 HWD	Yes ¹	UJ486	Sige Axle
1.938"	5.841"	4 HWD	No	UJ57956	Mechanics 7C
1.94" (1 15/16")	4.25" (4 1/4")	4 DWT	Yes ⁵	UJ895²³	Rockwell 58WB Mechanics 6.5C
		4 HWD	Yes ⁵	UJ894²³	
		2 DWT & 2 HWD	Yes ⁵	UJ896²³	
1.94" (1 15/16")	4.62" (4 5/8")	4 LWT	Yes ¹	UJ570¹⁵	Mechanics 7C Rockwell 72N
		4 DWT	Yes ¹	UJ770	
		4 LWD	Yes ¹	UJ575¹⁵	
		4 HWD	Yes ¹	UJ927	
		4 HWD	Yes ⁷	UJ482	
		2 LWT & 2 LWD	Yes ¹	UJ572¹⁵	
		2 LWT & 2 HWD	Yes ¹	UJ574¹⁵	
		2 DWT & 2 HWD	Yes ¹	UJ774	

(Continued)

1 Regular lube fitting in cross

3 Long lube fitting in cross

5 Two regular lube fittings in cross

6 Two angled lube fittings in cross

7 Four long lube fittings in cross

8 Regular lube fitting in bearing

14 Two HWD bearings double keyed for CV

15 Our production uses delta wing brgs. in place of low wing bearings

23 Includes 12 pt cap screws

Heavy duty truck U-Joints

U-joints with 4 wing bearings

Dimension A Across Bearing	Dimension B Across U-joint	Bearing Quantity and Type	Lube Fitting	Part Number	OE Series
1.94" (1 15/16")	6.88" (6 7/8")	4 LWT	Yes ¹	UJ581¹⁵	Mechanics 8C Rockwell 82N
		4 HWD	Yes ¹	UJ928	
		4 DWT	Yes ¹	UJ781	
		2 DWT & 2 HWD	Yes ¹	UJ783	
		2 LWT & 2 HWD	Yes ¹	UJ583¹⁵	
2.81" (2 13/16")	4.88" (4 7/8")	4 LWT	Yes ⁶	UJ785¹⁵	Rockwell 85WB Mechanics 8.5C
		4 DWT	Yes ⁶	UJ785	
		4 LWD	Yes ⁶	UJ787^{15,23}	
		4 HWD	Yes ⁶	UJ963	
2.81" (2 13/16")	6.44"	4 LWT	Yes ¹	UJ69014	Mechanics 9C
		2 LWT & 2 HWD	Yes ¹	UJ69017	
2.81" (2 13/16")	6.62" (6 5/8")	4 LWD	Yes ¹	UJ911CB²³	Mechanics 9C Rockwell 92N
		4 HWD	Yes ¹	UJ911	
		2 DWT & 2 HWD	Yes ⁵	UJ792	
3.62"	6.50" (6 1/2")	4 HWD	No	UJ61076	

1 Regular lube fitting in cross

3 Long lube fitting in cross

5 Two regular lube fittings in cross

6 Two angled lube fittings in cross

7 Four long lube fittings in cross

8 Regular lube fitting in bearing

14 Two HWD bearings double keyed for CV

15 Our production uses delta wing brgs. in place of low wing bearings

23 Includes 12 pt cap screws

U-joints with 2 wing bearings & 2 grooved round bearings

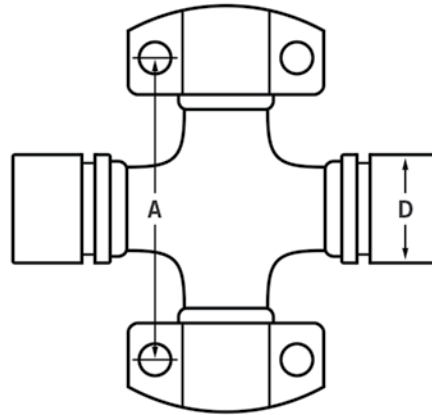

Dimension A Across U-joint	Bearing Diameter & Type	Lube Fitting	Part Number	OE Series
2.34" (2 11/32")	2 1.000" Round Grooved and 2 Low Wing Drilled	Yes ⁸	UJ522	Mechanics 2
2.75" (2 3/4")	2 1.125" Round grooved and 2 Low Wing Threaded	Yes ¹	UJ531G	Mechanics 3
3.44" (3 7/16")	2 1.125" Round Grooved and	Yes ¹	UJ544	Mechanics 4
	2 Low Wing Threaded	Yes ¹	UJ546	
	2 Low Wing Drilled	Yes ¹	UJ494	
3.50" (3 1/2")	2 1.313" Round Grooved and	Yes ³	UJ554¹⁵	Mechanics 5
	2 Low Wing Threaded	Yes ³	UJ557¹⁵	
4.50" (4 1/2")	2 1.313" Round Grooved and	Yes ¹	UJ565	Mechanics 6
	2 High Wing Drilled			
4.62" (4 5/8")	2 1.625" Round Grooved and	Yes ³	UJ483	Mechanics 7
	2 High Wing Drilled			

1 Regular lube fitting in cross
 3 Long lube fitting in cross
 8 Regular lube fitting in bearing

15 Our production uses delta wing brgs.
 in place of low wing bearings

Heavy duty truck U-Joints

U-joints with 2 wing bearings & 2 plain round bearings or 2 welded plate round bearings
(Mechanics & Rockwell to Spicer)

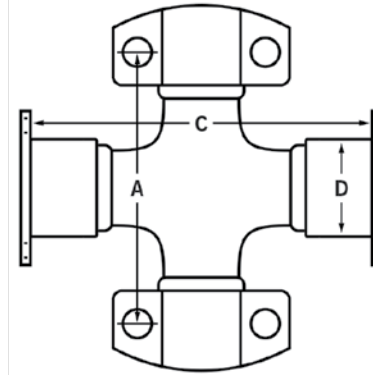
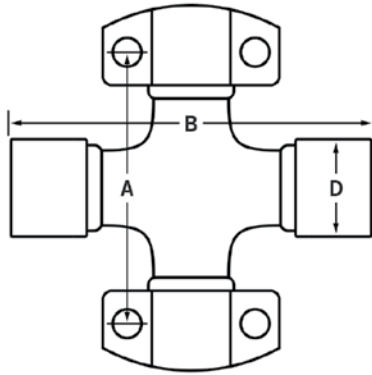

Bearing Type & Diameter	Dimensions A & B / C	Lube Fitting	Part Number	OE Series
2 Low Wing Threaded and 2 1.063" Round Plain	A 2.34" (2 11/32") and B 3.22" (3 7/32")	Yes ⁸	UJ506	Mechanics 2C to Spicer 1310
2 Low Wing Threaded and 2 1.188" Round Plain	A 3.44" (3 7/16") and B 4.19" (4 3/16")	Yes ¹	UJ547	Mechanics 4C to Spicer 1410
2 High Wing Drilled and 2 1.375" Round Plain	A 3.50" (3 1/2") and B 4.19" (4 3/16")	Yes ¹	UJ559	Mechanics 5C to Spicer 1480
2 High Wing Drilled and 2 1.375" Round Plain	A 4.25" (4 1/4") and B 4.97" (4 31/32")	Yes ¹	UJ484	Rockwell 58WB to Spicer 1550
2 High Wing Drilled and 2 1.375" Round Plain	A 4.50" (4 1/2") and B 4.97" (4 31/32")	Yes ¹	UJ470	Mechanics 6C to Spicer 1550
2 Delta Wing Threaded and 2 1.375" Round Plain	A 4.50" (4 1/2") and B 4.97" (4 31/32")	Yes ¹	UJ474	
2 High Wing Drilled and 2 2.06" Round Plain	A 6.63" and B 8.20"	No	UJ60025	Meritor 25R
2 High Wing Drilled and	A 6.62" (6 5/8") and			Mechanics 9C to
2 1.937" Round w/Welded Plate	C 7.55" (7 35/64v)	Yes ⁵	UJ480	Spicer 1810
2 2.186" Round w/Welded Plate	C 8.09" (8 3/32")	Yes ¹	UJ488	Spicer 1880

1 Regular lube fitting in cross
5 Two regular lube fittings in cross

8 Regular lube fitting in bearing

SKF Vehicle Aftermarket Support

Scan the QR code to visit the official SKF Vehicle Aftermarket website

View the latest SKF innovative products, access the complete product range and technical support.



Follow the SKF Vehicle Aftermarket on social media!



Contact SKF Technical Support to help resolve your automotive problems

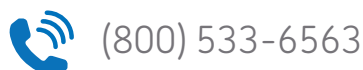

© SKF is a registered trademark of the SKF Group. | © SKF Group 2022.

The contents of this publication are the copyright of the publisher and may not be reproduced (even extracts) unless prior written permission is granted. Every care has been taken to ensure the accuracy of the information contained in this publication but no liability can be accepted for any loss or damage whether direct, indirect or consequential arising out of the use of the information contained herein.

Publication 457285 EN • October 2022 • Printed in U.S.A.